

WINDSOR CONFERENCE 2014

COUNTING THE COST OF COMFORT

PROCEEDINGS

WINDSOR CONFERENCE 2014 COUNTING THE COST OF COMFORT IN A CHANGING WORLD

8th Windsor Conference
International Conference
held 10th - 13th April 2014, Windsor, UK

Edited by
Prof Fergus Nicol
Prof Susan Roaf
Dr Luisa Brotas
Prof Rev Michael Humphreys

ORGANIZED BY



SUPPORTED BY



Published by NCEUB 2014
To order go online to www.nceub.org.uk

Proceedings of 8th Windsor Conference: Counting the Cost of Comfort in a
Changing World

Cumberland Lodge, Windsor, UK, 10th-13th April 2014
Network for Comfort and Energy Use in Buildings, <http://nceub.org.uk>

Copyright in the contents, the cover, the design and the typographical arrangement of this publication rests with the NCEUB unless otherwise stated. Copyright of the individual papers remains with the Authors. The Editors do not accept any responsibility for the content of the papers herein published. The contents of this publication may be reproduced free of charge in any format or medium for the purposes of private research and study or for internal circulation within an organisation. This is subject to the contents being reproduced accurately and not in a way that implies official status. The reproduced material must be acknowledged as NCEUB Copyright and the title of the publication specified. Any other use of the contents of this publication would require a copyright licence or written authorisation by the Authors.

ISBN 978-0-9928957-0-9

Copyright © NCEUB 2014

WINDSOR CONFERENCE 2014

COUNTING THE COST OF COMFORT

Preface to the Proceedings of the 8th Windsor Conference 2014 at Cumberland Lodge, Windsor

For many the costs of providing acceptable indoor temperatures have become prohibitive. In Japan energy rationing has become necessary after the destruction of the Fukushima nuclear plant. The repercussions in the Japanese energy markets have made critical choices necessary. Do organisations cut back on plant operation times or widen the range of acceptable working temperatures in their work places? Many around the world already have had to make stark choices on whether to spend money on heating and cooling or on eating. How far do the ordinary boundaries of company or family budgets have to be stretched before comfort conditions are significantly compromised and what are the consequences of that happening?

Despite increasingly sophisticated simulations buildings too often still overheat. At some point the serious challenge of achieving reductions in energy consumption and carbon emissions must be faced without compromising the comfort, health, well-being and productivity of building occupants. Where do cost effective solutions lie? Better climatic design of buildings? More efficient equipment? De-mechanisation of building systems? Occupant behaviours? Reshaped building regulations?

What is the role of comfort researchers in helping to design a new generation of resilient buildings that help mitigate climate change and are adapted to withstand its impacts? How do we measure the costs and benefits of different approaches to the provision of comfort in 21st century buildings and their resulting economic impacts? The provision of reliable, safe and affordable thermal comfort in buildings is a core priority for designers as the costs of energy rise and the global impacts of its use become ever clearer on our landscapes and in our changing climate.

The 8th Windsor Conference, held from 10th – 13th April 2014 focused comfort research into the real world context of providing building designers, owners and users with clear and comprehensible measures of what the actual money, energy, carbon, health, well-being, productivity and comfort costs might be in applying different comfort stratagems to the challenging social, climatic, constructional and economic contexts around us. Traditionally the subject of comfort was dominated by the physics of comfort and its language, but in an unpredictable world more difficult issues of values, perceptions, behaviours and controls are critical too. The provision of comfort can no longer be seen in isolation – as an activity detached from cost or impact.

It is 20 years since we first came to Cumberland Lodge and in that time not only our own ideas and approaches to the field have changed radically but also so has the world around us. We can mark some of the steps in those changes through our conferences. In 2014 we are exploring how extreme temperatures and the rising costs of energy might be accommodated in our standards, architectural designs and research thinking and practice. There are workshops exploring new laboratory design approaches, statistics, building types and associated design issues such as daylight and our fundamental approach to the concept and understanding of comfort as a personal choice or a negotiated reality. All this is on offer in addition to keeping in touch with the latest development in related products and controls design and approaches and standards, policies and legislation around the world.

These questions are the basis of the 98 papers contained in this volume. The papers were written by many of the 120 experts from 22 countries who attended the 8 plenary sessions and 9 workshops of the conference. Keynote speeches were delivered by three leading experts. This compilation of papers will become an essential source for academics, researchers, building designers and managers as well anyone interested in new knowledge, approaches and technologies.

We would like to acknowledge members of our Scientific Committee for blind reviews of abstracts and papers presented here.

Fergus Nicol, Sue Roaf, Luisa Brotas, Michael Humphreys

April 2014

ORGANIZING COMMITTEE

Fergus Nicol, London Metropolitan University (UK),
Susan Roaf, Heriot-Watt University (UK),
Luisa Brotas, London Metropolitan University (UK),
Michael A Humphreys, Oxford Brookes University (UK).

SCIENTIFIC COMMITTEE

Michael Adebamowo, University of Lagos (NG),
Edward Arens, University of California, Berkeley (US),
Philomena Bluysen, Delft University of Technology (NL),
Atze Boerstra, BBA Binnenmilieu (NL),
Gail Brager, University of California, Berkeley (US),
Luisa Brotas, London Metropolitan University (UK),
Richard de Dear, The University of Sydney (AU),
Dusan Fiala, ErgonSim (DE),
Andy Ford, London South Bank University (UK),
Rajat Gupta, Oxford Brookes University (UK),
Jake Hacker, Arup (UK),
George Havenith, Loughborough University (UK),
Michael A Humphreys, Oxford Brookes University (UK),

Tri Harso Karyono, Tanri Abeng Univerity (ID),
Madhavi Indraganti Prince Sultan University College for Women (SA),
Maria Kolokotroni Brunel University (UK),
Jarek Kurnitski, Tallinn University of Technology (EE),
Alison Kwok, University of Oregon (US),
Ashok Lall, Ashok B Lall Architects (IN),
Roberto Lamberts, Federal University of Santa Catarina (BR),
Hal Levin, Building Ecology Research Group (US),
Giancarlo Mangone, Delft University of Technology (NL),
Azadeh Montazami, Coventry University (UK),
Fergus Nicol, London Metropolitan University (UK),
Marialena Nikolopoulou, University of Kent (UK),
Bjarne W. Olesen, Danish Technical University (DK),
Mark Olweny, Uganda Martyrs University (UG),
Ryozo Ooka University of Tokyo (JP),
Ken Parsons, Loughborough University (UK),
Jens Pfafferott, Hochschule Offenburg (DE),
Adrian Pitts, University of Huddersfield (UK),
Iftikhar Raja, COMSATS Institute of Information Technology (PK),
Hom Rijal, Tokyo City University (JP),
Kosonen Risto, Aalto University (FI),
Susan Roaf, Heriot-Watt University (UK),
Darren Robinson, The University of Nottingham (UK),
Mattheos Santamouris, University of Athens (GR),
Olli Seppänen, REHVA (FI),
Fionn Stevenson, University of Sheffield (UK),
Shin-ichi Tanabe, WASEDA University (JP),
Despoina Teli, University of Southampton (UK),
Paul Tuohy, University of Strathclyde (UK),
Peter Wouters, Belgian Building Research Institute (BE),
Da Yan, Tsinghua University (CN),
Runming Yao, University of Reading (UK).

COLLABORATORS

Jonida Murataj, London Metropolitan University (UK),
Kevin Bowe, Heriot-Watt University (UK).

eBook-PDF of Proceedings and website designed by Luisa Brotas
webdesign of www.windsorconference.com by Richard Roaf

WINDSOR CONFERENCE 2014

COUNTING THE COST OF COMFORT

TIMETABLE and ATTENDEES

8th Windsor Conference 2014
COUNTING THE COST OF COMFORT IN A CHANGING

International Conference held 10th - 13th April 2014
at Cumberland Lodge, Windsor Great Park, UK

WINDSOR CONFERENCE 2014

COUNTING THE COST OF COMFORT

COUNTING THE COST OF COMFORT IN A CHANGING WORLD

International Conference held 10th - 13th April 2014, at Cumberland Lodge, Windsor Great Park, UK

8th Windsor Conference 2014



ORGANIZING COMMITTEE

Fergus Nicol, Susan Roaf, Luisa Brotas and Michael Humphreys

SCIENTIFIC COMMITTEE

Michael Adebamowo (NG), Edward Arens (US), Philomena Bluysen (NL), Atze Boerstra (NL), Gail Brager (US) Luisa Brotas (UK), Richard de Dear (AU), Dusan Fiala (DE), Andy Ford (UK), Rajat Gupta (UK), Jake Hacker (UK), George Havenith (UK), Michael A Humphreys (UK), Tri Harso Karyono (ID) Madhavi Indraganti (SA), Maria Kolokotroni (UK), Jarek Kurnitski (EE), Alison Kwok (US), Ashok Lall (IN), Roberto Lamberts (BR), Hal Levin (US), Giancarlo Mangone (NL), Azadeh Montazami (UK), Fergus Nicol (UK), Marialena Nikolopoulou (UK), Bjarne W. Olesen (DK), Mark Olweny (UG), Ryozo Ooka (JP), Ken Parsons (UK), Jens Pfafferott (DE), Adrian Pitts (UK), Iftikhar Raja (PK), Hom Rijal (JP), Kosonen Risto (FI), Susan Roaf (UK), Darren Robinson (UK), Mattheos Santamouris (GR), Olli Seppänen (FI), Fionn Stevenson (UK), Shin-ichi Tanabe (JP), Despoina Teli (UK), Paul Tuohy (UK), Peter Wouters (BE), Da Yan (CN), Runming Yao (UK)

TIMETABLE

Thursday 10th April 2014

After Dinner Talk - Invited Chair: Fergus Nicol



Gail Brager

20:00 Evolving opportunities in providing thermal comfort

Friday 11th April 2014

SESSION 1: Affordable domestic comfort in the 21st Century 09:00 - 11:00 Invited Chairs: Maria Kolokotroni and Ryozo Ooka



Hom B. Rijal, Michael A. Humphreys and J. Fergus Nicol

09:00 Development of the adaptive model for thermal comfort in Japanese houses



Angela Simone, Marta Avantaggiato, Michele De Carli and Bjarne W. Olesen

09:15 Effect of passive cooling strategies on overheating in low energy residential buildings for Danish climate



Mikk Maivel, Jarek Kurnitski and Targo Kalamees

09:30 Summer Thermal Comfort in New and Old Apartment Buildings



Anna Mavrogianni, Jonathon Taylor, Chrysoula Thoua, Michael Davies and John Kolm-Murray

09:45 A coupled summer thermal comfort and indoor air quality model of urban high-rise housing



Haiyan Yan and Liu Yang

10:00 Indoor thermal conditions and thermal comfort in residential buildings during the winter in Lhasa, China



Elangovan Rajasekar, R. Soumya and Rajan Venkateswaran

10:15 Challenges in designing for comfort – Comfort and energy use characterization in residential apartments

COLLABORATORS

Kevin Bowe, Jonida Murataj



Konstantinos Palantzidis and Luisa Brotas

10:30 The Greek Housing Stock and the Role of the Occupant's Behaviour in Achieving Energy Efficiency



Alfredo Fernandez-Gonzalez

10:35 Characterization of Thermal Comfort in a Passively Cooled Building Located in a Hot-Arid Climate



Hikaru Imagawa and Hom B Rijal

10:40 Survey on the thermal comfort and occupant behaviour in the bedrooms of Japanese houses



Discussion

10:45



COFFEE BREAK

11:00

SESSION 2: Controlling Comfort

11:30 - 13:00

Invited Chairs: Hom Rijal and Madhavi Indraganti



Sally Salome Shahzad, John Brennan and Dimitris Theodossopoulos

11:30 Individual Thermal Control in the Workplace and Changes in Thermal Preferences in a Day: Norwegian Cellular vs. British Open Plan Layouts



Shen Wei, Richard Buswell and Dennis Loveday

11:45 A comparison of alternative occupant classification approaches for the modelling of window opening behaviour in office buildings



Maohui Luo, Bin Cao and Yingxin Zhu

12:00 A field study to validate the positive effects of individual control on thermal comfort in residential buildings



Margot Pellegrino

12:15 Thermal judgements and adaptive behaviours: a study on the subjective side of thermal comfort in two University buildings in France.



Runa T. Hellwig

12:30 User friendliness and building automation - A conceptual approach to understanding perceived control



Kathryn Healey

12:45 Applying contextual understanding in mixed mode design: a user-centred study of thermal comfort and adaptive control



Discussion

12:50



LUNCH

13:00

SESSION 3: Comfort in Offices and Educational buildings

14:00 - 16:00

Invited Chairs: Richard de Dear and Sue Roaf



Alkis Kotopouleas and Marialena Nikolopoulou

14:00 Understanding thermal comfort conditions in airport terminal buildings



Madhavi Indraganti, Ryoza Ooka, Hom B Rijal and Gail S Brager

14:15 Occupant behaviour and obstacles in operating the openings in offices in India



Richard de Dear, Jungsoo Kim, Christhina Candido and Max Deuble

14:30 Summertime Thermal Comfort in Australian School Classrooms



Simi Hoque and Ben Weil

14:45 Cold comfort: thermal satisfaction in academia



A. Hussin, E. Salleh, H.Y. Chan and S. Mat

15:00 Thermal Comfort during daily prayer times in an Air-Conditioned Mosque in Malaysia



Eefke van den Ouweland, Wim Zeiler, Yvonne de Kort, Gerarda Nierman, Gert Boxem and Wim Maassen

15:15 A holistic approach to comfort in offices

SUPPORTED BY



London Metropolitan University
www.londonmet.ac.uk



Sir John Cass Faculty of Art Architecture and Design
www.thecass.com



Heriot-Watt University
www.hr.ac.uk

ORGANISED BY



Network for Comfort and Energy Use in Buildings
www.nceub.org.uk

WINDSOR 2014
CONFERENCE
COUNTING THE COST OF COMFORT

WINDSOR CONFERENCE 2014
8th Windsor Conference International Conference
held 10th-13th April 2014
at Cumberland Lodge Windsor Great Park, UK
www.windsorconference.com



A. Merlino, S. Viazzo, D. Freda, P. Capone, M. Del Gaudio, P. Lenzuni

15:20 Cost effectiveness of thermal mitigation based on the long term thermal analysis of a large office building



Ricardo Forgiarini Rupp and EneDir Ghisi

15:25 Choosing a method of thermal comfort for mixed-mode office buildings located in hot-humid summer climate



Min Li, Bin Cao and Yingxin Zhu

15:30 Indoor thermal comfort survey in campus buildings (classrooms) in Beijing for a long time



Asit Kumar Mishra and Maddali Ramgopal

15:35 Adaptive comfort relations and comfort temperature ranges from a field study in undergraduate laboratories



Ashak Nathwani

15:40 Case study: thermal comfort evaluations in prayer halls in two continents.



Maureen Trebilcock, Jaime Soto and Rodrigo Figueroa

15:45 Thermal comfort in primary schools: a field study in Chile



Discussion

15:50



COFFEE BREAK

16:00

WORKSHOP 1: Comfort, user behaviour and energy efficiency

16:30 - 18:30

Invited Chairs: Jens Pfafferott and Atze Boerstra

Flitcroft Room



Workshop description

16:30 Comfort, user behaviour and energy efficiency



Fionn Stevenson, Magda Baborska-Narozny

16:40 Designing resilient housing for co-evolutionary adaptivity



Anoop Honnekeri, Gail Brager, Shivraj Dhaka and Jyotirmay Mathur

17:00 Comfort and adaptation in mixed-mode buildings in a hot-dry climate



Discussion

17:20

WORKSHOP 2: Schools and young people

16:30 - 18:30

Invited Chairs: Despoina Teli and Azadeh Montazami

Hodgson Room



Workshop description

16:30 Schools and young people



Azadeh Montazami and Mark Gaterell

16:40 Occupants' behaviours in controlling blinds in UK primary schools



Despoina Teli, Patrick A.B. James and Mark F. Jentsch

16:55 Do the constants used in adaptive comfort algorithms reflect the observed responses of children in junior school classrooms?



Shamila Haddad, Paul Osmond, Steve King, Shahin Heidari

17:10 Developing assumptions of metabolic rate estimation for primary school children in the calculation of the Fanger PMV model



Discussion

17:25

WORKSHOP 3: Overheating in buildings

16:30 - 18:30

Invited Chair: Fergus Nicol

Greening Room



Workshop description

16:30 Overheating in buildings



Linda Gichuyia and Koen Steemers

16:40 Indoor Overheating Risk and Climate Change. Modelling sensitivity of building design parameters for a free-running building

ATTENDEES

Australia

Lyrian Daniel

The University of Adelaide

Richard de Dear

The University of Sydney

Shamila Haddad

University of New South Wales

Kathryn Healey

University of Queensland

Ashak Nathwani

University of Sydney

Daniel Ryan

University of Sydney

Ben Slee

University of Sydney

Brazil

Roberto Lamberts

Federal University of Santa Catarina

EneDir Ghisi

Federal University of Santa Catarina

Eduardo Krüger

Technological University of Parana

Chile

Jaime Soto

Universidad del Bío-Bío

Maureen Trebilcock

Universidad del Bío-Bío

Christopher J. Whitman

Universidad Central de Chile

P. R. China

Bin Cao

Tsinghua University

Li Huang

Tsinghua University

Min Li

Tsinghua University

Maohui Luo

Tsinghua University

Xiaochuan Tan

Tsinghua University

 **Craig Farnham and Kazuo Emura**
17:00 Case Study: Thermal Comfort in a Water Mist on Hot Summer Days

 **Kevin Bowe**
17:20 Does PMV unnecessarily restrict natural ventilation in buildings?

 **Discussion**
17:25

WORKSHOP 4: Dynamic thermal environment: What is the mechanism? How to create, control and evaluate it? 16:30 - 18:30
Invited Chair: Yingxin Zhu Sandby Room

 **Workshop description**
16:30 Dynamic thermal environment: What is the mechanism? How to create, control and evaluate it?

 **Li Huang, Yingxin Zhu, Edward Arens, Hui Zhang and Qin Ouyang**
16:40 Applicability of elevated air movement for maintaining thermal comfort in warm environments

 **Ryozo Ooka, Madhavi Indraganti and Hom B Rijal**
17:00 Comfort temperature and the adaptive use of environmental controls in offices in Japan

 **Alexandre Freire, José Luís Alexandre and Fergus Nicol**
17:20 Adaptive comfort opportunities under mechanically conditioned environment

 **V. Fabi, V. Maggiora, SP. Corgnati and Rune Andersen**
17:25 Occupants' behaviour in office building: stochastic models for window opening.

 **Discussion**
17:30

POSTERS Session I 18:30 - 19:00

 **DINNER**
19:00

After Dinner Talks 20:30 - 21:30
Invited Chair: Michael Humphreys

 **Miles Allen**
20:30 Climate change and the limits of comfort

 **Wouter van Marken Lichtenbelt**
21:00 Turning up the heat – physiological implications of a changing thermal environment

Saturday 12th April 2014

SESSION 4: The physiology of thermal comfort 09:00 - 11:00
Invited Chairs: Lisje Schellen and Jacob Verhaart

 **Hannah Pallubinsky, Lisje Schellen and Wouter van Marken Lichtenbelt**
09:00 Thermoregulatory behaviour in response to switching thermal environments – a pilot experiment prior to a mild warm acclimation study

 **Wouter van Marken Lichtenbelt, Lisje Schellen, Christel Jacquot and Boris Kingma**
09:15 Energy efficient living - INTEWON Physiology and behaviour: the elastic thermal comfort zone and the need for categorization

 **Lisje Schellen, Hannah Pallubinsky and Wouter van Marken Lichtenbelt**
09:30 The relation between the thermoneutral zone and thermal comfort zone - Determination of the thermoneutral zone and the influence on thermal behaviour

 **Madhavi Indraganti, Juyoun Lee, Hui Zhang and Edward A. Arens**
09:45 Versatile Indian sari: Clothing insulation with different drapes of typical sari ensembles

Yingxin Zhu
Tsinghua University

Denmark

Karsten Andersen
VELUX A/S

Rune K. Andersen
Technical University of Denmark

Bjarne W. Olesen
Danish Technical University

Angela Simone
Technical University of Denmark

Estonia

Mikk Maivel
Tallinn University of Technology

Finland

Olli Seppänen
REHVA

France

Pierre Lombard
Saint Gobain Recherche

Margot Pellegrino
University of Paris Est

Ariane Schumacher
Saint-Gobain Glass

Germany

Peter Bröde
IfADo

Runa T. Hellwig
Augsburg University of Applied Sciences

Jens Pfafferott
Hochschule Offenburg

Marcel Schweiker
Karlsruhe Institute of Technology











Andreas Wagner
Karlsruhe Institute of Technology

India



Asit Kumar Mishra
Indian Institute of Technology Kharagpur

-  **Derek Vissers, Wim Zeiler, Gert Boxem, Michal Vezely and Jacob Verhaart**
10:00 Neuron fire rates simulations of cold thermal sensations validated by measurements
-  **Minjung Kim, Yoorim Choi, Jieun Han, Youngjoo Son and Chungyoon Chun**
10:15 An experiment on attention ability based on Electroencephalogram (EEG) in different PMV Conditions
-  **Yoorim Choi, Yongmin Kim and Chungyoon Chun**
10:20 The occupants' stress on each PMV condition – chamber study using brain wave
-  **M. Veselý and W. Zeiler**
10:25 Tracking hand movement in an infrared image
-  **Masanari Ukai, Yuta Ichikawa and Tatsuo Nobe**
10:30 Field Study of Thermal Environment Acceptability Using Ostracon Voting Device
-  **Discussion**
10:35
-  **COFFEE BREAK**
11:00

SESSION 5: Lighting, acoustics and building physics **11:30 - 13:00**
Invited Chairs: Luisa Brotas and Adrian Pitts

-  **John Goins**
11:30 On finding balance between collaborative noise and speech privacy in open offices
-  **Luisa Brotas and Jan Wienold**
11:45 Solar Reflected glare affecting visual performance
-  **M S. Franco, M R. Kessler and M. Samangoei**
12:00 Analysing the Resilience of Brasília's Superblocks in a Changing Climate
-  **Margaret Pigman, Hui Zhang, Anoop Honnekeri, Ed Arens, and Gail Brager**
12:15 Visualizing the results of thermal comfort field studies: putting publicly accessible data in the hands of practitioners
-  **Pierre Lombard**
12:30 Measure and model of free hanging sound absorbers impact on thermal comfort
-  **Ben Slee, Anir Upadhyay and Richard Hyde**
12:35 Evaluating the influence of thermal mass and window size in a direct gain system on the annual and lifetime energy consumption of domestic Australian light weight construction
-  **Juliana Felkner**
12:40 Effect of Structure and Morphology on Natural Ventilation Potentials, Comfort, and Energy Use in Tall Buildings
-  **Shailza Singh, P.S Chani and S.Y Kulkarni**
12:45 Implication of building energy modeling (BEM) and adaptive model to assess the efficiency of multi storied apartments in composite climate of north India
-  **Discussion**
12:50
-  **LUNCH**
13:00

SESSION 6: Outdoor comfort and Urban Heat Island effect **14:00 - 16:00**
Invited Chairs: Roberto Lamberts and Chungyoon Chun

-  **Peter Bröde, Eduardo L. Krüger and Dusan Fiala**
14:00 Residual analysis of UTCI predictions on outdoor thermal sensation survey data
-  **Shinji Yoshida, Taiki Sato and Masayuki Oguro**
14:15 Study on Evaluation of Effects of Inhomogeneous Radiant Environment for Pedestrian in Summer Season using a Coupled Numerical Simulation based on CFD Analysis

Elangovan Rajasekar
L&T Construction

Shailza Singh
Indian Institute of
Technology

Ireland

Fahad Abalkheil
University College
Dublin

Italy

Paolo Lenzuni
Italian National
Workers'
Compensation
Authority

Japan

Craig Farnham
Osaka City University

Genki Hoshino
Tokyo City University

Hikaru Imagawa
Tokyo City University

Tatsuo Nobe
Kogakuin University

Ryoza Ooka
University of Tokyo

Hom Bahadur Rijal
Tokyo City University

Hatsuki Takahashi
Japan Minka Revival
Association

Masanari Ukai
kogakuin University

Noriko Umemiya
Osaka City University

Shinji Yoshida
University of Fukui

Korea

Yoorim Choi
Yonsei University

Chungyoon Chun
Yonsei University

Jieun Han
Yonsei University

Minjung Kim
Yonsei University

Yongmin Kim
Yonsei University

Youngjoo Son
Yonsei University

**Juan J Lafuente and Luisa Brotas**

14:30 The impact of the Urban Heat Island in the energy consumption and overheating of domestic buildings in London

**Indrika Rajapaksha and Chathuri Rathnayaka**

14:45 Thermal acceptability for urban parks in tropics: Evaluating the effects of environmental attributes on user perceived controls

**Genki Hoshino and Hom B. Rijal**

15:00 Investigation of the outdoor thermal comfort and clothing insulation in Hachiko Square in Tokyo

**Eduardo Krüger and Peter Bröde**

15:15 Analyzing night time wind speed reduction effects from densification on predicted outdoor thermal comfort in a subtropical setting

**Guoying Hou and Christopher Tweed**

15:30 A field study of thermal comfort in transitional spaces in buildings in Cardiff, UK

**Chungyoon Chun**

15:35 ASHRAE database

**Discussion**

15:50

**COFFEE BREAK**

16:00

WORKSHOP 5: Daylight and Comfort **16:30 - 18:30**
Invited Chairs: Luisa Brotas and Jan Wienold **Flitcroft Room**

**Workshop description**

16:30 Daylight and Comfort

**Zoltán Nagy, Mike Hazas, Mario Frei, Dino Rossi and Arno Schlueter**

16:40 Illuminating Adaptive Comfort: Dynamic Lighting for the Active Occupant

**V. Fabi, V. Camisassi, F. Causone, SP. Corgnati and Rune Andersen**

17:00 Light switch behaviour: occupant behaviour stochastic models in office buildings

**Isabelle Leysens and Ulrike Passe**

17:20 Towards a Dynamic Daylight Understanding

**Discussion**

17:40

WORKSHOP 6: Using statistics correctly to analyse comfort and behaviours **16:30 - 18:30**
Invited Chairs: Jane & Rex Galbraith with Michael Humphreys

**Workshop description**

16:30 Using statistics correctly to analyse comfort and behaviours

**Abdulrahman Alshaikh, Susan Roaf and Robert Smith**

16:40 What is the relationship between humidity and comfort at high temperatures? In search of new ways of looking at the issue

**Discussion**

17:00

WORKSHOP 7: Instrumentation and climate chambers **16:30 - 17:30**
Invited Chairs: Andreas Wagner and Marcel Schweiker **Greening Room**

**Workshop description**

16:30 Instrumentation and climate chambers

**Marcel Schweiker, Sabine Brasche, Maren Hawighorst, Wolfgang Bischof and Andreas Wagner**

16:40 Presenting LOBSTER, an innovative climate chamber, and the analysis of the effect of a ceiling fan on the thermal sensation and performance under summer conditions in an office-like setting

**Discussion**

17:00

Malaysia**Azman Hussin**

Universiti Kebangsaan
Malaysia

Netherlands**Atze Boerstra**

BBA Binnenmilieu

Katarina Katic

Eindhoven University
of Technology

Stanley R. Kurvers

Delft University of
Technology

Wouter van Marken

Lichtenbelt
Maastricht University

Hannah Pallubinsky

Maastricht University

Arjen K. Raue

Utrecht University

Lisje Schellen

Maastricht University

Jacob Verhaart

Eindhoven University
of Technology

Michal Vesely

Eindhoven University
of Technology

Nigeria**Michael Adebamowo**

University of Lagos

Toks Sangowawa

KOA Consultants Ltd

Portugal**Eusébio Conceição**

University of Algarve

Alexandre Freire

University of Porto

Saudi Arabia**Madhavi Indraganti**

Prince Sultan
University College for
Women

Sri Lanka**Indrika Rajapaksha**

University of Moratuwa

Chathuri Rathnayaka

University of Moratuwa

WORKSHOP 8: Negotiated comfort
Invited Chair: Gary Raw

17:30 - 18:30
Greening Room

 **Workshop description**

17:30 Negotiated comfort

 **Rajat Gupta and Mariam Kapsali**

17:40 Evaluating the effect of occupant behaviour and expectations on actual energy use and environmental conditions in 'sustainable' social housing in South East England

 **Discussion**

17:55

WORKSHOP 9: Standards: developments of EN15251

Invited Chair: Bjarne Olesen

17:30 - 18:30

Hodgson Room

 **Workshop description**

17:30 Standard prEN15251 and new standard ISO-DIS 17772

 **A.C. Boerstra, J. van Hoof and A.M. van Weele**

17:40 A New Hybrid Thermal Comfort Guideline for the Netherlands (ISSO 74: 2014)

 **Renata De Vecchi, Márcio J. Sorgato, Miguel Pacheco, Christhina Cândido and Roberto Lamberts**

17:55 Application of the adaptive model proposed by ASHRAE 55 in the Brazilian climate context: raising some issues

 **Discussion**

18:10

POSTERS Session II

18:30 - 19:00

 **DINNER**

19:00

Sunday 13th April 2014

SESSION 7: Thermal comfort, productivity and occupant behaviour

Invited Chair: Olli Seppänen and Noriko Umemiya

09:00 - 11:00

 **Joe L. Leyten, Arjen K. Raue and Stanley R. Kurvers**

09:00 Robust Design for high workers' performance and low absenteeism – An alternative approach

 **Hom B. Rijal, Toshiaki Omori, Michael A. Humphreys and J. Fergus Nicol**

09:15 A field-comparison of thermal comfort with floor heating systems and air conditioning systems in Japanese homes

 **J. Verhaart, M. Veselý, S. Kik and W. Zeiler**

09:30 Personal heating: energy use and effectiveness

 **Noriko Umemiya and Tomohiro Taniguchi**

09:45 Cross-Correlations among daily variations of Thermal Control Use, Thermal Sensation, Clothing Insulation and Outdoor Temperature during Cooling Season in Japan

 **Eusébio Z. E. Conceição, Maria Manuela J. R. Lúcio and Hazim B. Awbi**

10:00 Improvement of comfort conditions using confluent jets ventilation located near the floor level in an experimental chamber

 **Nelly Adriana Martinez**

10:15 Solving the Black Box: Inverse Approach for Ideal Building Dynamic Behaviour Using Multi-Objective Optimization with Energyplus

 **Adrian Pitts**

10:30 Prevalence and Evaluation of Bioclimatic Design Techniques used to achieve Low Energy Comfort in Architectural Design Proposals

Switzerland

Juliana Felkner

ETH Zurich

Zoltán Nagy

ETH Zurich

Jan Wienold

Ecole Polytechnique
Fédérale de Lausanne

United Kingdom

Timothy Adekunle

University of Kent

Feyikemi

Akinwolemiwa
Cardiff University

Myles Allen

University of Oxford

Abdulrahman

Alshaikh Heriot-Watt
University

Sergio Altomonte

The University of
Nottingham

Magda Baborska-Narozny

University of Sheffield

Ali El Bakkush

Heriot-Watt University

Kevin Bowe

Heriot-Watt University

Luisa Brotas

London Metropolitan
University

Harvey Brown

University of Oxford

Jane Galbraith

University College
London

Rex Galbraith

University College
London

Stephanie Gauthier

UCL Energy Institute

Linda Gichuyia

University of
Cambridge

Rajat Gupta

Oxford Brookes
University

Mike Hazas

Lancaster University

Michael Humphreys

Oxford Brookes
University

 **Ryozo Ooka, Rongling Li, Togo Yoshidomi and Bjarne W. Olesen,**
10:35 Field evaluation of the performance of a radiant heating/cooling ceiling panel system

 **Stephanie Gauthier and David Shipworth**
10:40 The gap between what is said and what is done: a method for distinguishing reported and observed responses to cold thermal discomfort

 **Shen Wei, Xiaoxin Wang, Rory Jones and Pieter de Wilde**
10:45 Using building performance simulation to save residential space heating energy: A pilot testing

 **Discussion**
10:50

 **COFFEE BREAK**
11:00

SESSION 8: The interaction between people and buildings 11:30 - 13:00
Invited Chairs: Pierre Lombard and Michael Adebamowo

 **Christopher J. Whitman and Neil Turnbull**
11:30 Environmental Comfort in the Living Heritage of the Chilean Araucanía: The Ruka Lafkenche and the Fogón Pehuenche.

 **Jared Langevin, Jin Wen, and Patrick L. Gurian**
11:45 Simulating the human-building interaction: Development and validation of an agent-based model of office occupant behaviours.

 **T. Adekunle and M. Nikolopoulou**
12:00 Post-occupancy and indoor monitoring surveys to investigate the potential of summertime overheating in UK prefabricated timber houses

 **Daniel J. Ryan**
12:15 Triumph in the Tropics? Surveying the thermal environment of the Queensland house 1905-1926

 **Lyrian Daniel, Terence Williamson, Veronica Soebarto and Dong Chen**
12:30 A Study of Thermal Mavericks in Australia

 **Akinwolemiwa Feyikemi and Gwilliam Julie**
12:45 The Effect of Climate and Culture on Housing among Low Income Groups in Lagos, Nigeria

 **Discussion**
12:50

 **LUNCH**
13:00

CLOSING SESSION
Invited Chair: Fergus Nicol

Guoying Hou
Cardiff University

Trevor Keeling
University of Reading

Maria Rita Kessler
Oxford Brookes University

Maria Kolokotroni
Brunel University

Alkis Kotopouleas
University of Kent

Juan J. Lafuente
London Metropolitan University

Matthew Lipson
Energy Technologies Institute

Anna Mavrogianni
University College London

Azadeh Montazani
Coventry University

Jonida Murataj
London Metropolitan University

Fergus Nicol
London Metropolitan University

Mariarena Nikolopoulou
University of Kent

Adrian Pitts
University of Huddersfield

Gary Raw
UCL Energy Institute

Susan Roaf
Heriot-Watt University

Darren Robinson
The University of Nottingham

Sally Salome Shahzad
University of Edinburgh

Seyed Sameni
Coventry University

Robbie Smith
Heriot-Watt University

Fionn Stevenson
University of Sheffield

Despoina Teli
University of Southampton

Gloria Vargas Palma
University of Sheffield

Shen Wei
Plymouth University

PAPERS appearing in the proceedings but authors unable to present

 **Harimi Djamila, Chi Chu Ming and Sivakumar Kumaresan**
Exploring the Dynamic Aspect of Natural Air flow on Occupants Thermal Perception and Comfort

 **Patricia R C Drach and Henrique Drach**
Mobile Meteorological Survey Station: Applying Measurement Tools on a bike to create the Meteobike

 **Alaa Sarhan, Bakr Gomaa, Mohamed Elcharkawi**
Daylight quality in healthcare architecture - Developing a framework

 **Tri Harso Karyono, Sani Heryanto and Ida Faridah**
Thermal comfort study of university students in Jakarta, Indonesia

 **Tokie Laotan-Brown**
African Green Design Solutions as Vernacular Bioclimatic Architecture

**Haiping Liu and Dexuan Song**

Effects of vegetation on thermal comfort in Shanghai high-density residential developments

**Weiwei Liu, Pawel Wargocki, Jing Xiong**

Occupant time period of thermal adaption to change of outdoor air temperature in naturally ventilated buildings

**Theodora Neroutsou**

Lifecycle Costing of Low Energy Housing Refurbishment: A case study of a 7 year retrofit in Chester Road, London

**Astrid Roetzel**

Considerations for occupant behaviour modelling in early design stages

**Masanori Shukuya**

Exergetic Review on Thermal Performance of Window Systems

**Mansoureh Tahbaz**

Outdoor thermal condition and people's exposure time - A case study of cold climate

USA**Gail Brager**

University of California

John Goins

Pacific Northwest
National Laboratory

Shan He

Iowa State University

Alfredo Fernandez-Gonzalez

University of Nevada,
Las Vegas

Isabelle Leysens

Iowa State University

Jared Langevin

Drexel University

Copyright © NCEUB 2014

WINDSOR CONFERENCE 2014

COUNTING THE COST OF COMFORT

AFTER DINNER TALKS

Evolving opportunities in providing thermal comfort
by Gail Brager

Invited Chair: Fergus Nicol

WINDSOR CONFERENCE 2014

COUNTING THE COST OF COMFORT

SESSION 1

Affordable domestic comfort in the 21st Century

Invited Chairs: Maria Kolokotroni and Ryozo Ooka

Development of the adaptive model for thermal comfort in Japanese houses

Hom B. Rijal¹, Michael A. Humphreys², J. Fergus Nicol²

¹ *Faculty of Environmental Studies, Tokyo City University, Yokohama, Japan*

² *School of Architecture, Oxford Brookes University, Oxford, UK*

¹rijal@tcu.ac.jp, ²mahumphreys@brookes.ac.uk, ²jfnicol@brookes.ac.uk

Abstract

This study was undertaken to investigate comfort temperatures and adaptive model in Japanese homes. We measured temperatures in the living rooms and bedrooms, and a thermal comfort survey of residents over a three year in Kanto region of Japan. The residents were found to be highly satisfied with the thermal environment of their houses. Significant seasonal differences were found in their comfort temperatures. The results showed that comfort temperature varied with changes in both the indoor and outdoor climate. The strength of the relationship between indoor and outdoor temperatures justified the adoption of the adaptive model for both prediction and design of control strategies for the provision of indoor comfort.

Keywords: Field survey; Griffiths' method; Comfort temperature; Adaptive model

Introduction

Indoor temperatures are an important factor in creating comfortable homes. An understanding of the locally required comfort temperature can be useful in the design of residences and their heating and cooling systems to avoid excessive energy use.

Comfort temperatures in houses have been widely investigated, with key studies in Japan (Nakaya et al. 2005, Rijal et al. 2013), Nepal (Rijal et al. 2010), Pakistan (Nicol & Roaf 1996) and UK (Rijal & Stevenson 2010). However there are limitations in the research to date with some studies conducted over short time periods, and some based on small samples. Comfort temperatures may also vary according to the month and season, requiring long-term data to fully understand perceptions and behavioural responses to comfort provision in the home.

In 2004 ASHRAE introduced an adaptive standard for naturally ventilated buildings (ASHRAE 2004) and CEN (2007) proposed an adaptive model for free-running naturally ventilated buildings. The adaptive model of thermal comfort was developed largely on the basis of thermal comfort surveys in European and American offices. No Japanese data was included. Occupant behaviour is different in the office and at home, and thus the existing adaptive models may not apply to residences.

There is evidence that people respond differently in their own homes for a number of reasons: social, economic and cultural (Oseland 1995). People at home usually are able to control their own thermal environments, so it may be wondered what is the purpose of knowing what temperatures they choose. Models relating the preferred indoor temperature to the climate are of course of scientific interest as an addition to our knowledge of the results of human adaptive behaviour. They are useful practically too. Knowing what indoor temperatures people are likely to require in winter and in summer helps towards the correct sizing of air conditioning and heating plant – oversized plant is usually less efficient. For the free-running mode of operation the situation is different. The question is then: can this proposed design provide the required indoor temperatures? If thermal simulation or experience suggests that it cannot, then the design can be altered, particularly with regard to window design and thermal

mass, so that comfort is more likely to be obtainable. The adaptive relation is a useful design tool.

In order to record seasonal differences in the comfort temperature and to develop a domestic adaptive model for Japanese residences, thermal measurements and a thermal comfort survey were conducted for more than 3 years in the living and bedrooms of residences in the Kanto region of Japan.

Field investigation

A thermal comfort survey and the thermal measurement were conducted in 121 houses in Kanto region (Kanagawa, Tokyo, Saitama and Chiba) of Japan from 2010 to 2013 (Table 1). The detail of surveys 1, 2 and 4 can be found at Rijal, Yoshimura (2011), Katsuno et al. (2012) and Rijal (2013) respectively.

The indoor air temperature and the relative humidity were measured in the living rooms and bedrooms, away from direct sunlight, at ten minute intervals using a data logger (Figure 1). The globe temperature was also measured in the living room in surveys 3, 4 & 5. The number of subjects was 119 males and 124 females. Respondents completed the questionnaire several times a day in the living rooms and twice in the bedroom (“before go to bed” and “after wake-up from the bed”) (Table 2).

The ASHRAE scale is frequently used to evaluate the thermal sensation, but the words “warm” or “cool” imply comfort in Japanese, and thus the SHASE scale (The Society of Heating, Air-Conditioning and Sanitary Engineers of Japan) is also used to evaluate the thermal sensation. To avoid a possible misunderstanding of “neutral”, it is explained as “neutral (neither cold nor hot)” (SHASE scale) or “neutral (neither cool nor warm)” (ASHRAE scale). It is also said that the optimum temperature occurs on the cooler side in summer and on the warmer side in winter (McIntyre 1980, Nakaya et al. 2005). We have collected 32,468 thermal comfort votes. Outdoor air temperature and relative humidity were obtained from the nearest meteorological station.

Table 1. Description of survey

Survey	Survey period		Surveyed room	Measured variables*	Number of houses	Number of subjects			Number of votes	
	Start date	End date				Male	Female	Total	Living room	Bedroom
1	06-7-2010	18-7-2011	Living, Bed	T_i, RH_i	11	16	14	30	3299	2558
2	05-8-2011	06-9-2011	Living	T_i, RH_i	55	52	57	109	2819	-
3	21-7-2011	08-5-2012	Living, Bed	T_i, RH_i, T_g	14	11	12	23	463	984
4	25-7-2012	24-6-2013	Living, Bed	T_i, RH_i, T_g	30	26	28	54	13083	7061
5	10-8-2013	03-10-2013	Living, Bed	T_i, RH_i, T_g	11	14	13	27	936	1265

T_i : Indoor air temperature (°C), RH_i : Indoor relative humidity (%), T_g : Indoor globe temperature (°C), *: T_g is measured only in the living room.

Table 2. Questionnaires for thermal comfort survey

No.	SHASE scale	ASHRAE scale	Thermal preference
	Now, how do you feel the air temperature?	Now, how do you feel the air temperature?	Now, how do you prefer the air temperature?
1	Very cold	Cold	Much warmer
2	Cold	Cool	A bit warmer
3	Slightly cold	Slightly cool	No change
4	Neutral (neither cold nor hot)	Neutral (neither cool nor warm)	A bit cooler
5	Slightly hot	Slightly warm	Much cooler
6	Hot	Warm	
7	Very hot	Hot	



Figure 1 Details of the thermal measurement

Results and discussion

The data were divided into three groups: the FR mode (free running), CL mode (cooling by air conditioning) and HT mode (heating). First we have determined the CL and HT modes based on actual cooling and heating used. Some in these categories used window opening to provide ventilation. Then, all the other data were classified as being in the FR mode. In previous research, the data is divided into two modes: free running and heated/cooled (CIBSE 2006, CEN 2007) or NV and HVAC building in the classification used in ASHRAE standard 55-2004. However, the CL and HT modes are two distinct groups of data (generally CL used in summer and HT is used in winter), and need to be analysed separately.

Distribution of outdoor and indoor temperature

The mean outdoor air temperatures during the voting were 19.5 °C, 27.6 °C and 7.2 °C for FR, CL and HT modes respectively (Figure 2). The mean indoor air temperatures during the voting were 24.2 °C, 27.3 °C and 19.2 °C for FR, CL and HT modes respectively. The Japanese government recommends the indoor temperature settings of 20 °C in winter and 28 °C in summer respectively. The results showed that the mean indoor temperatures during heating and cooling were close to the recommendation. The mean indoor and outdoor temperature difference was 4.7 K, -0.3 K and 12.0 K for FR, CL and HT modes respectively. The results show that the seasonal difference of the indoor air temperature is quite large, and that the data represent a wide range of outdoor temperature.

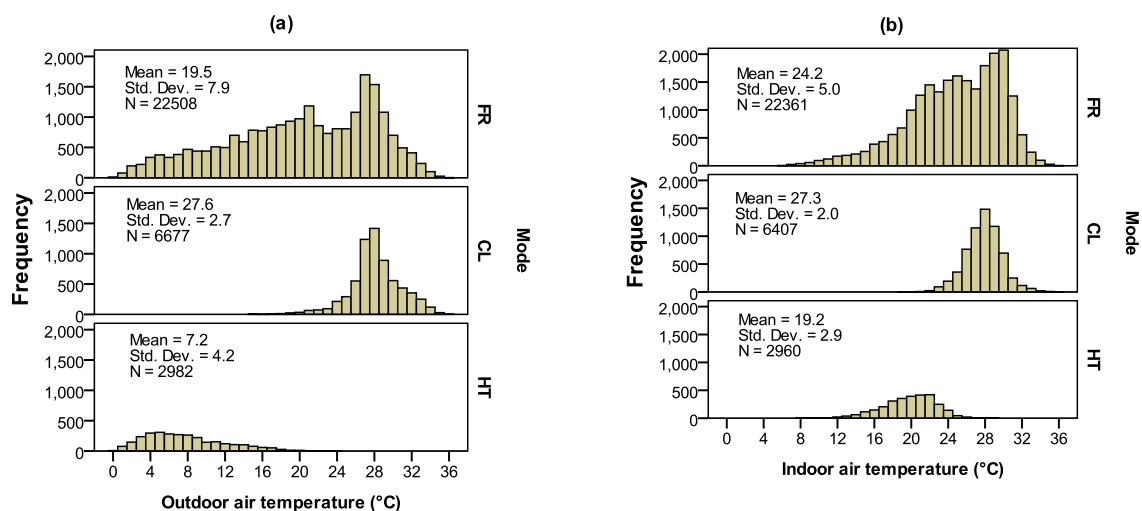

Figure 2 Distribution of outdoor and indoor air temperature in various modes.

Comparison of the scales

We have analysed the performance of ASHRAE and SHASE scales by regressing the thermal response on the indoor air temperature, using the data collected from people in their living rooms and bedrooms. Table 3 compares the relevant regression statistics.

It is apparent that the thermal sensation when expressed on the SHASE scale correlates much more closely with the indoor air temperature than it does when expressed on the ASHRAE scale. It also has a smaller residual standard deviation, which indicates that people agree more closely on their sensation at any particular temperature (their responses are more similar) when this scale is used. The regression coefficients are similar on the two scales. It can be concluded that the SHASE scale is superior for these data, and should be used to present the results.

The preference scale has fewer categories (5 rather than 7) and so its regression coefficient and residual standard deviation are not directly comparable with the seven-category scales. Its correlation with temperature is quite high at 0.62. Its purpose is different from that of the SHASE scale, and so it should be retained.

Table 3 Regression analysis of thermal sensation and thermal preference

Scale	Number of votes	Regression coefficient/K	Correlation coefficient	Residual standard deviation	Overall standard deviation of thermal sensation
ASHRAE	21,045	0.130	0.485	1.066	1.219
SHASE	31,749	0.113	0.616	0.704	0.894
Preference	29,293	0.092	0.617	0.563	0.716

Distribution of thermal sensation

Mean thermal sensation vote was 4.1 in FR mode, 4.2 in CL mode and 3.5 in HT mode. Residents sometimes felt hot (greater than 4) in CL mode and sometimes felt cold (less than 4) in HT mode (Table 4). Even though residents used the heating or cooling, they sometimes felt “cold” or “hot”. As there are many “4 neutral” votes in FR mode, it can be said that residents were generally satisfied in the thermal environment of the houses. This may be due to the adaptation of the residents to the local climate and culture.

Table 4 Percentage of thermal sensation in each mode

Mode	Items	Thermal sensation							Total
		1	2	3	4	5	6	7	
FR	N	93	907	3,532	12,757	3,776	1,323	281	22,669
	Percentage (%)	0.4	4.0	15.6	56.3	16.7	5.8	1.2	100
CL	N	13	52	514	4,639	1,226	245	60	6,749
	Percentage (%)	0.2	0.8	7.6	68.7	18.2	3.6	0.9	100
HT	N	54	357	757	1,836	46	-	-	3,050
	Percentage (%)	1.8	11.7	24.8	60.2	1.5	-	-	100

N: Number of sample

Prediction of the comfort temperature

Regression method

Regression analysis of the thermal sensation and indoor air temperature was conducted to predict the comfort temperature (Figure 3). The following regression equations are obtained for the thermal sensation (C) and indoor air temperature (T_i , °C).

$$\text{FR mode} \quad C=0.123T_i+1.11 \quad (n=22,346, R^2=0.44, \text{S.E.}=0.001, p<0.001) \quad (1)$$

$$\text{CL mode} \quad C=0.091T_i+1.66 \quad (n=6,400, R^2=0.07, \text{S.E.}=0.004, p<0.001) \quad (2)$$

$$\text{HT mode} \quad C=0.103T_i+1.50 \quad (n=2,900, R^2=0.14, \text{S.E.}=0.005, p<0.001) \quad (3)$$

n: Number of sample, R^2 : Coefficient of determination, S.E.: Standard error of the regression coefficient, p : Significant level of regression coefficient.

The regression coefficient and correlation coefficient for the FR mode are higher than for the CL and HT modes. When the comfort temperature is predicted by substituting “4 neutral” in the equations (1) to (3), it would be 23.5 °C in the FR mode, 25.7 °C in the CL mode and 24.3 °C in the HT mode. The comfort temperature of the HT mode is unrealistically high. This might be due to the problem of applying the regression method in the presence of adaptive behaviour, where it can be misleading when used to estimate the comfort temperature, as has been found in previous research (Rijal et al. 2013). So to avoid the problem the comfort temperature is estimated using the Griffiths method in next section.

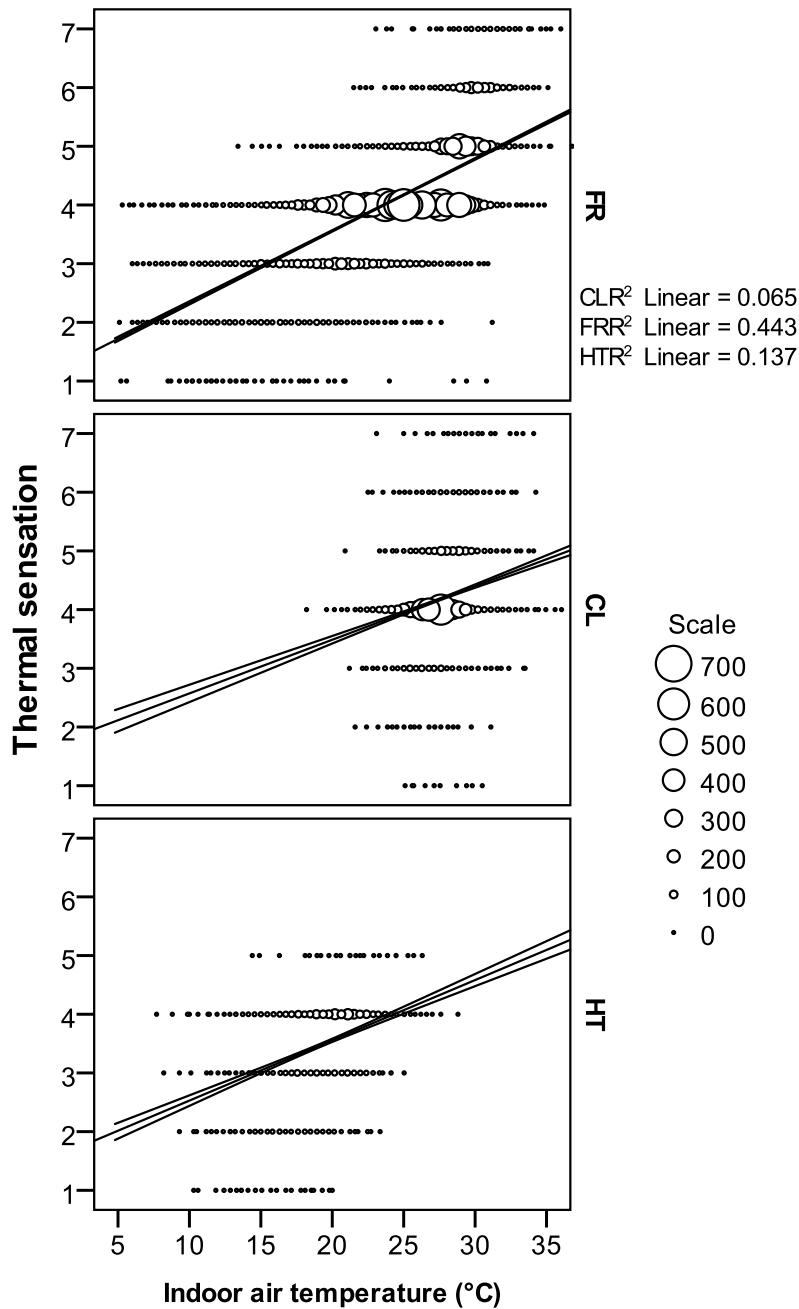

Figure 3 Relation between the thermal sensation and indoor air temperature

Griffiths' method

The comfort temperature is predicted by the Griffiths' method (Griffiths 1990, Nicol et al. 1994, Rijal et al. 2008).

$$T_c = T_i + (4 - C) / a \quad (4)$$

T_c : The comfort temperature by Griffiths' method (°C), C : Thermal sensation vote, a : The rate of change of thermal sensation with room temperature.

In applying the Griffiths' method, Nicol et al. (1994) and Humphreys et al. (2013) used the constants 0.25, 0.33 and 0.50 for a 7 point thermal sensation scale. We have also investigated the comfort temperature using these regression coefficients. The mean comfort temperature with each coefficient is similar (Table 5), so it matters little which coefficient is adopted. The comfort temperature calculated with the coefficient 0.50 is used for further analysis.

The mean comfort temperature by the Griffiths' method is 24.1 °C in FR mode, 27.0 °C in CL mode and 20.2 °C in HT mode (Figure 4). We chose to use the Griffiths method because in the presence of adaptation ordinary regression can give misleading values for the comfort temperatures. In our data powerful adaptation to the seasonal variation of indoor temperature necessitates the use of the Griffiths method.

Table 5 Comfort temperature predicted by Griffiths' method

Mode	Regression coefficient	Number of sample	Comfort temperature (°C)	
			Mean (°C)	Standard deviation (°C)
FR	0.25	22,346	23.9	3.8
	0.33	22,346	24.0	3.8
	0.50	22,346	24.1	4.0
CL	0.25	6,400	26.7	3.0
	0.33	6,400	26.8	2.5
	0.50	6,400	27.0	2.1
HT	0.25	2,960	21.3	3.4
	0.33	2,960	20.8	3.0
	0.50	2,960	20.2	2.7

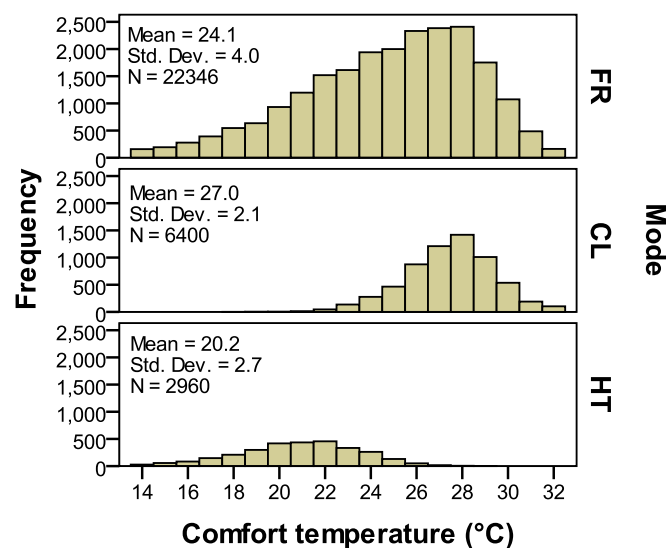

Figure 4 Prediction of comfort temperatures from each observation by Griffiths' method in each mode

Seasonal difference in comfort temperature

In this section, to clarify the seasonal difference, the comfort temperature for each month and season is investigated (Figures 5 and 6). The comfort temperature does not vary much within the winter or summer seasons. However, it is quite changeable in the spring and autumn. The results showed that the comfort temperature changes according to the season, and thus it is related to the changes in indoor and outdoor air temperature which occur in spring and autumn. The comfort temperature by the Griffiths' method is 18.1 °C in winter, 21.9 °C in spring, 27.1 °C in summer and 24.3 °C in autumn in FR mode. Thus, the seasonal difference of the mean comfort temperature is 9.0 K which is similar to the value found in previous research (Rijal et al. 2010 & 2013). The comfort temperature of the heating HT mode also changes significantly from season to season (Figure 6).

We have compared the comfort temperatures from the FR mode with the values from previous research, which were probably also chiefly from this mode (Table 6). The comfort temperature found in previous research ranges from 8.4 to 30.0 °C. The wider range may suggest that the comfort temperature has regional differences.

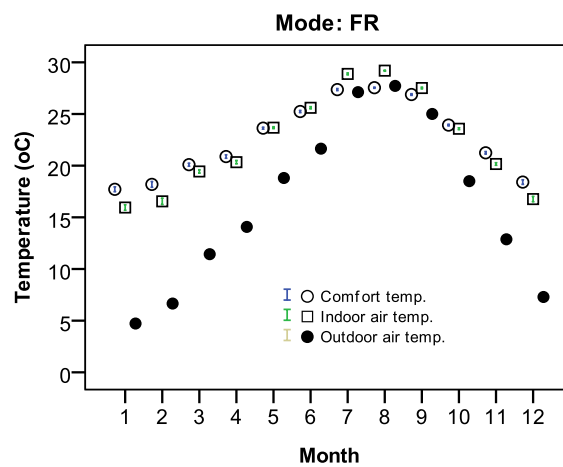

Figure 5 Monthly mean comfort temperature with 95% confidence intervals predicted by Griffiths' method

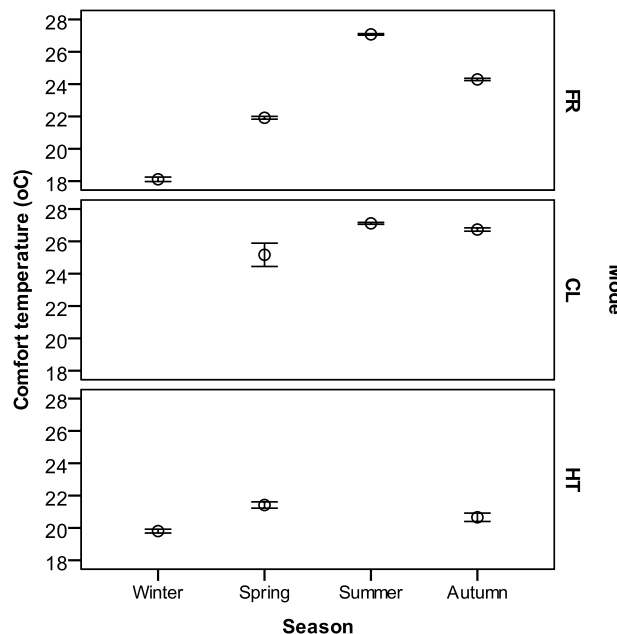

Figure 6 Seasonal difference of comfort temperature with 95 % confidence intervals by Griffiths' method

Table 6 Comparison of comfort temperature with previous research

Area	Reference	Comfort temperature (°C)			
		Winter	Spring	Summer	Autumn
Japan (Kanto)	This study (FR mode)	18.1	21.9	27.1	24.3
Japan (Gifu)	Rijal et al. (2013)	15.6	20.7	26.1	23.6
Japan (Kansai)	Tobita et al. (2007)	9.9~10.9	-	-	-
Japan (Kansai)	Nakaya et al. (2005)	-	-	27.6	-
Nepal	Rijal et al. (2010)	13.4~24.2	-	21.1~30.0	-
Nepal	Rijal & Yoshida (2006)	8.4~12.9	-	-	-
Pakistan	Nicol & Roaf (1996)	19.8~25.1	-	26.7~29.9	-
UK	Rijal & Stevenson (2010)	19.4	19.7	22.9	21.3

The adaptive model

Running mean outdoor temperature

The running mean outdoor temperature is the exponentially weighted daily mean outdoor temperature, and it is calculated using the following equation (McCartney & Nicol 2002).

$$T_{rm} = \alpha T_{rm-1} + (1-\alpha)T_{od-1} \quad (5)$$

Where, T_{rm-1} is the running mean outdoor temperature for the previous day (°C), T_{od-1} is the daily mean outdoor temperature for the previous day (°C). So, if the running mean has been calculated (or assumed) for one day, then it can be readily calculated for the next day, and so on. α is a constant between the 0 and 1 which defines the speed at which the running mean responds to the outdoor air temperature. In this research α is assumed to be 0.8.

Linear regression equations

An adaptive model relates the indoor comfort temperature to the outdoor air temperature (Humphreys 1978, Humphreys & Nicol 1998, ASHRAE 2004, CEN 2007). Figure 7 shows the relation between the comfort temperature calculated by the Griffiths' method and the running mean outdoor temperature. The regression equations are given below.

$$\text{FR mode} \quad T_c = 0.453T_{rm} + 15.0 \quad (n=22,346, R^2=0.68, \text{S.E.}=0.002, p<0.001) \quad (6)$$

$$\text{CL mode} \quad T_c = 0.188T_{rm} + 21.9 \quad (n=6,400, R^2=0.03, \text{S.E.}=0.014, p<0.001) \quad (7)$$

$$\text{HT mode} \quad T_c = 0.178T_{rm} + 18.8 \quad (n=2,960, R^2=0.05, \text{S.E.}=0.014, p<0.001) \quad (8)$$

T_c : Comfort temperature by Griffiths' method (°C), T_{rm} : the exponentially-weighted running mean outdoor temperature for the day (°C). (S.E. is the standard error of the regression coefficient.)

The regression coefficient and the correlation coefficient in the FR mode are higher than in the CL and HT modes. The regression coefficient in the FR mode is higher than that in the CEN standard (=0.33). The CEN standard is based on the field investigation in the office buildings, and therefore may not apply to dwellings, where residents have more freedom to adapt. For example, when the running mean outdoor temperature is 25 °C, 28 °C and 10 °C, the comfort temperature would be 26.3 °C, 27.2 °C and 20.6 °C for the FR, CL and HT modes respectively.

In the HT mode, the variation of comfort temperature is high. In this research, we have also included the *Kotatsu* (small table with an electric heater underneath and covered by a quilt) in the HT mode, and thus people may find it comfortable at low indoor air temperatures. When a *Kotatsu* of 90 W (power consumption) is used, there is more than 7 °C thermal comfort effect when room temperature is 11 °C (Watanabe et al. 1997). This may account for the wide range of comfort temperatures found in this research.

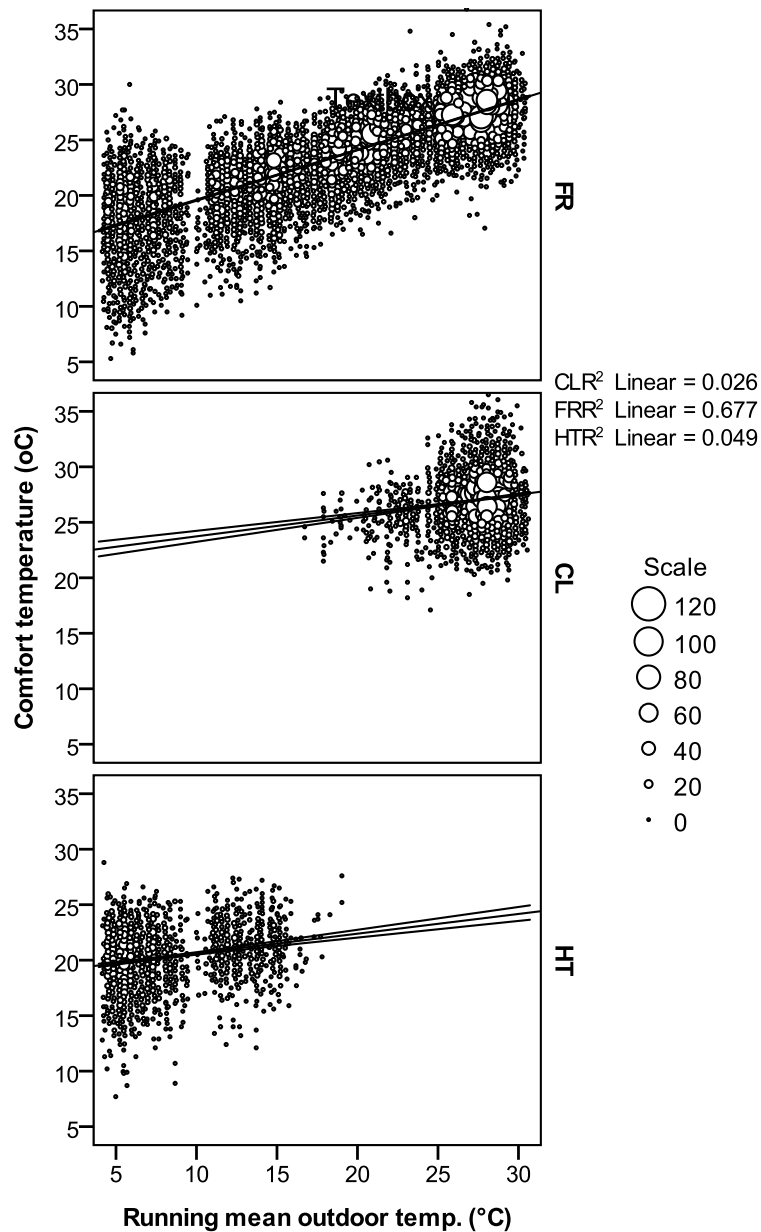
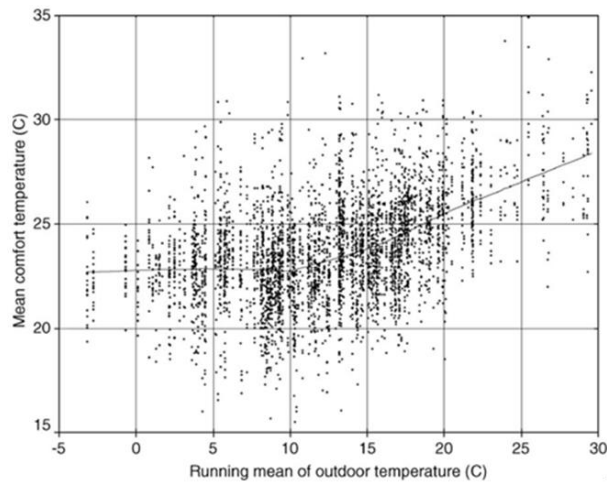

Figure 7 Relation between the comfort temperature and the running mean outdoor temperature in each mode

Comparison with adaptive model

Figure 8 shows the variation of the comfort temperature in the CEN standard (Nicol & Humphreys 2007), Japanese houses (Rijal et al. 2013) and in this research. When we compare the regression lines of these three figures, it is very similar in the hot environment (about 25~30 °C). In the European research, when outdoor running mean temperature is below 12 °C, the comfort temperature is almost constant (Figure 8 (a)). On the other hand, in the Japanese houses, when outdoor running mean temperature is below 12 °C, the comfort temperature is also gradually decreasing. In the research in European offices, people might not be so free to adjust the thermal environment, and thus people may not adapt well at low temperatures. In this research, residents are free to adjust the thermal environment in their home, and thus they might be adapting well in the low outdoor temperature compared to the office buildings.

(a) CEN standard (Nicol & Humphreys 2007)



(b) Gifu, Japan (Rijal et al. 2013)

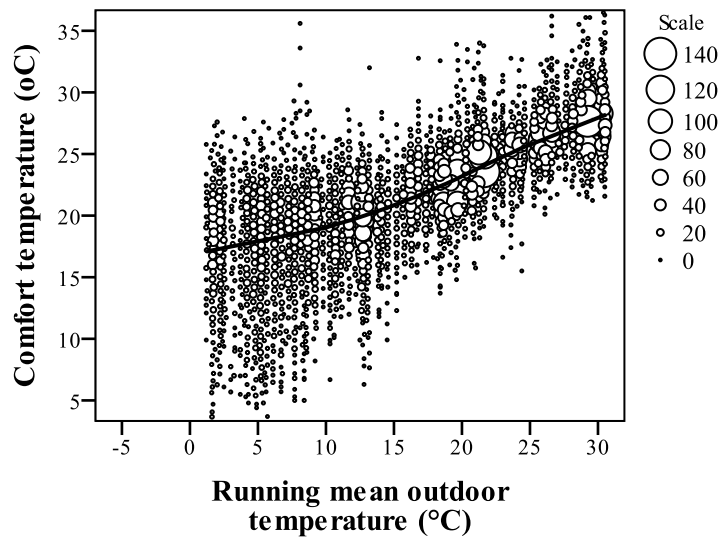

(c) This research

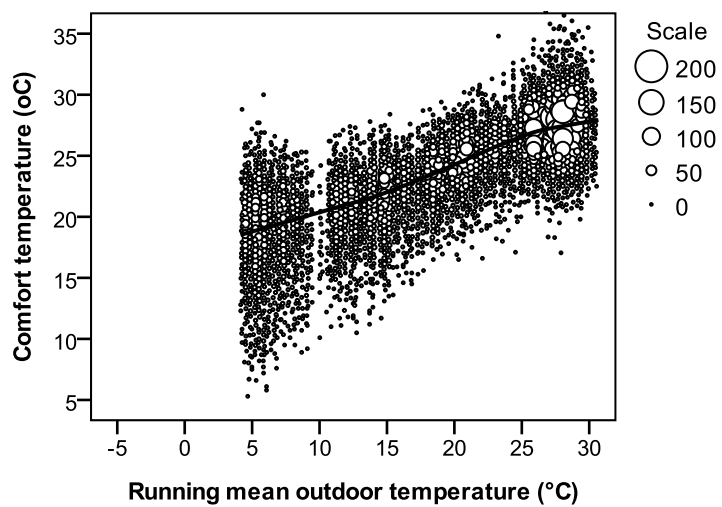

Figure 8 Variation of the comfort temperature in previous and this research.

Conclusions

A thermal comfort survey of the residents of the Kanto region of Japan was conducted over three years. The thermal environment in living rooms and bedrooms were investigated. The following results were found:

1. The residents proved to be highly satisfied with the thermal environment of their homes, as indicated by the high proportion of 'neutral' responses.
2. The average comfort temperature was 27.0 °C when cooling was used, 20.2 °C when heating was used, and 24.1 °C when neither heating nor cooling were used (the FR mode).
3. The comfort temperatures in spring and autumn were very similar. The seasonal difference (summer and winter) in comfort temperature was very high at 9.0 K.
4. An adaptive relation between the comfort temperature indoors and the outdoor air temperature could be an effective tool for predicting comfort temperature and for informing control strategies.

Acknowledgements

We would like to thank to all people who participated in the survey, to Kawamoto Industries, Ltd, Japan for their cooperation and to all students for data entry. This research was supported by Grant-in-Aid for Scientific Research (C) Number 24560726.

References

- ASHRAE Standard 55 (2004), Thermal environment conditions for human occupancy, Atlanta, Georgia, American Society of Heating Refrigeration and Air-conditioning Engineers.
- CIBSE (2006), Environmental Design. CIBSE Guide A, Chapter 1, Environmental criteria for design. London: Chartered Institution of Building Services Engineers.
- Comité Européen de Normalisation (CEN) (2007), EN 15251: Indoor Environmental Input Parameters for Design and Assessment of Energy Performance of Buildings Addressing Indoor Air Quality, Thermal Environment, Lighting and Acoustics, CEN, Brussels.
- Griffiths I.D. (1990), Thermal comfort in buildings with passive solar features: Field studies. Report to the Commission of the European Communities. EN3S-090 UK: University of Surrey Guildford.
- Humphreys M.A. (1978), Outdoor temperatures and comfort indoors, *Building Research and Practice (Journal of CIB)*, 6(2): 92-105.
- Humphreys M.A., Nicol J.F. (1998), Understanding the Adaptive Approach to Thermal Comfort, *ASHRAE Transactions* 104(1): 991-1004.
- Humphreys M.A., Rijal H.B. and Nicol J.F. (2013), Updating the adaptive relation between climate and comfort indoors; new insights and an extended database, *Building and Environment*, 63: pp. 40-55.
- Humphreys M.A., Nicol J.F. (2006), Chapter 1, Environmental criteria for design, Environmental Design: CIBSE Guide A. London, CIBSE.
- Katsuno J., Rijal H.B., Kikuchi S. (2012), Investigation of the comfort temperature and adaptive model in Japanese houses in summer, *Proceedings of 7th Conference: The changing context of comfort in an unpredictable world*, Windsor, UK, 12-15 April 2012. London: Network for Comfort and Energy Use in Buildings.
- McIntyre D.A. (1980), Indoor climate. London: Applied Science Publishers, Ltd.
- McCartney K.J., Nicol J.F. (2002), Developing an adaptive control algorithm for Europe, *Energy and Buildings*, 34 (6): 623-635.

- Nakaya T., Matsubara N., Kurazumi Y. (2005), A field study of thermal environment and thermal comfort in Kansai region, Japan: Neutral temperature and acceptable range in summer, *J. Environ. Eng., AIJ, No.597*: 51-56.
- Nicol F., Jami G.N., Sykes O., Humphreys M., Roaf S., Hancock M. (1994), A survey of thermal comfort in Pakistan toward new indoor temperature standards, Oxford Brookes University, Oxford England.
- Nicol J.F., Humphreys M.A. (2004), A stochastic approach to thermal comfort – occupant behavior and energy use in buildings. *ASHRAE Transactions*, 110(2): 554-568.
- Nicol F., Roaf S. (1996), Pioneering new indoor temperature standards: the Pakistan project, *Energy and Buildings* 23: 169-174.
- Nicol J.F., Humphreys M.A. (2007), Maximum temperatures in European office buildings to avoid heat discomfort, *Solar Energy* 81 (3): 295-304.
- Oseland N.A. (1995), Predicted and reported thermal sensation in climate chambers, offices and homes. *Energy and Buildings*, 23(2): 105-115.
- Rijal H.B., Stevenson F. (2010), Thermal comfort in UK housing to avoid overheating: lessons from a ‘Zero Carbon’ case study, *Proceedings of Conference: Adapting to change: New thinking on comfort*, Windsor, UK, 9-11 April 2010. London: Network for Comfort and Energy Use in Buildings.
- Rijal H.B., Tuohy P., Humphreys M.A., Nicol J.F., Samuel A., Raja I.A., Clarke J. (2008), Development of adaptive algorithms for the operation of windows, fans and doors to predict thermal comfort and energy use in Pakistani buildings. *ASHRAE Transactions*, 114 (2): 555-573.
- Rijal H.B., Yoshida H. (2006), Winter thermal comfort of residents in the Himalaya region of Nepal, *Proceedings of International Conference on Comfort and Energy Use in Buildings - Getting them Right (Windsor)*, Organised by the Network for Comfort and Energy Use in Buildings.
- Rijal H.B., Yoshida H., Umemiya N. (2010), Seasonal and regional differences in neutral temperatures in Nepalese traditional vernacular houses, *Building and Environment*, 45(12): 2743-2753.
- Rijal H.B., Yoshimura S. (2011), Investigation of comfort temperature in naturally ventilated and air condition mode in Japanese houses, *The 4th International Conference on the Human-Environment System (ICHES 2011)*: 259-264, 3-6 October, Sapporo, Japan.
- Rijal H.B., Honjo M., Kobayashi R. and Nakaya T. (2013), Investigation of comfort temperature, adaptive model and the window opening behaviour in Japanese houses, *Architectural Science Review*, 56(1): p. 54-69.
- Rijal H.B. (2013), Field investigation of comfort temperature and adaptive model in Japanese houses, *PLEA2013 - 29th Conference, Sustainable Architecture for a Renewable Future*, Munich, Germany 10-12 September 2013.
- Tobita K., Nakaya T., Matsubara N., Kurazumi Y., Shimada R. (2007), Calculation of neutral temperature and acceptable range by the field study of houses in Kansai area, Japan, in winter, *J. Environ. Eng., AIJ, No. 614*: 71-77.
- Yoshimura S., Rijal H.B., Kikuchi S. (2012), Research on the comfort temperature and the adaptive model of houses, *AIJ Kanto Chapter Architectural Research Meeting*: 13-116.
- Watanabe S., Horikoshi T., Miyoshi Y., Miyamoto S. (1997), Thermal effect of heating lower extremities of the human body using Kotatsu on the human thermal comfort, *J. Archit. Plann. Environ. Eng., AIJ, No. 497*: 47-52.

Proceedings of 8th Windsor Conference: *Counting the Cost of Comfort in a changing world* Cumberland Lodge, Windsor, UK, 10-13 April 2014. London: Network for Comfort and Energy Use in Buildings, <http://nceub.org.uk>

Effect of passive cooling strategies on overheating in low energy residential buildings for Danish climate

Angela Simone^{1,*}, Marta Avantaggiato², Michele De Carli² and Bjarne W. Olesen¹

1 International Centre for Indoor Environment and Energy, BYG, Technical University of Denmark, Denmark, email asi@byg.dtu.dk

2 Department of Industrial Engineering, University of Padova, Italy

Abstract

Climate changes have progressively produced an increase of outdoors temperature resulting in tangible warmer summers even in cold climate regions. An increased interest for passive cooling strategies is rising in order to overcome the newly low energy buildings' overheating issue. The growing level of air-tightness plays in low-energy buildings a double-acting role: reduction of energy demand and lack of adequate infiltration rate. In particular, the last one combined with higher outside air temperatures brings these new concepts buildings to progressively experience higher indoor temperatures creating not negligible thermal discomfort. In the present work the effect of passive strategies, such as solar shading and natural night-time ventilation, are evaluated through computer simulations. The analyses are performed for 1½-storey single-family house in Copenhagen's climate. The main result is that a crossed use of both strategies leads to a cooling demand reduction that varies between 98%-100% depending on the building's insulation.

Keywords: low-energy building, overheating, passive cooling strategies

1. Introduction

Climate changes have progressively produced increased outdoor temperatures resulting in warmer summers experienced also in cold climate regions. Since 1870 in Denmark the outdoor average temperature has increased approximately 1.5 °C and for the following 30 years it is estimated a faster increase with an average from 1 °C to 1.4 °C (DMI, 2014).

According to the EPBD Directive (2010) and its energy efficiency measures, the "Nearly/Net Zero Energy Building" are the only European target to follow in buildings' constructions till 2020. The directive has brought to some changes in the design process mainly concentrated on an increase of buildings' airtightness, which results in reduction of energy demand but also in lack of adequate infiltration rate.

The increased buildings' airtightness, the increase of outdoor temperatures, combined with the wider use of larger windows' surfaces brought to a rising experience of higher indoor temperatures creating not negligible thermal discomfort.

Concerns about solutions to overcome the low energy buildings' overheating issue results today in an increased interest and new challenge for designers to be considered in providing energy efficient buildings with good indoor climate.

Orme et al (2003) found that the most important factors causing overheating in well-insulated buildings are *solar radiation* and the *ventilation rate*. The importance of solar radiation impact on eight passive houses located in Denmark has been also reported by Larsen et al (2012). They demonstrated that larger windows areas in the southern building facade increase the solar gain reducing the heating demand in winter, but on the other end bring to critical thermal condition in summer, outside of the comfort categories suggested in EN 15251 (2006). The higher solar radiation load and higher windows temperatures could generate thermal discomfort resulting as a consequence in high cooling demand.

Internal gains, like occupants and equipment, have also a relevant impact on overheating, as demonstrated in Janson's (2010) work through the measurements performed in Swedish houses. This work showed also that tenants whom experienced an excessive indoor temperature had also considerable electricity consumption with higher appliances use. Additionally, through questionnaires, it was found that the desired indoor temperature varied between 20 °C to 23 °C and most tenants wanted 22-23 °C.

Passive cooling techniques and solutions, based on the interaction of the building and its surroundings, are the strategies that use climatic resources instead of electrical energy to create comfortable indoor environment. It is the strategy to be considered in order to solve overheating issue at low/zero energy cost.

It is not a new concept for buildings' cooling techniques (e.g. breezes flowing through windows, water evaporative from springs and fountains as well as large amounts of stone and earths absorbing daytime heat), but, over thousands years, it has been developed and integrated in building design. Today, called "passive cooling", it can also be seen as integration to the use of buildings' mechanical systems with the following reduction of the pumps and/or fans energy consumption.

Solar shading and natural ventilation are the most used passive cooling strategies for decreasing the heat absorption from direct solar radiation and increasing the penetration of colder air with zero energy use.

Night-time cooling ventilation, recirculation of fresh air through windows or specific building envelope openings, is the most used cooling strategy in climatic zones with high diurnal temperature variation where as a consequence thermal discomfort can be avoided. Pearlmutter and Meir (1995) also reported that the best performance in term of less fluctuating indoor temperature is obtained in high thermal mass buildings.

Night-time cooling ventilation can be a very powerful technique, while can also present considerable restrictions as condensation and moisture problems, privacy and/or security problems, incoming of outside air pollution, and acoustic problems. The use of this cooling technique and the evaluation of its limitative applicability are strongly associated with the specific climatic conditions.

In the cold climate region of Denmark the night cooling potential is very high, however the weather conditions, mostly rainy in summer, can be very limitative for the applicability.

In the Danish near zero energy buildings the increase of overheating issue and the possibility of its reduction/nullification at low/zero energy cost by the use of passive strategies, solar shading and/or night cooling ventilation, is here analyzed. In particular, this study aims to evaluate the possibilities of using night cooling

ventilation looking also at the restriction of its applicability; alternative solutions were also evaluated considering some users' habits.

2. Starting Consideration

When looking at the weather data over a year of Denmark, and in particular at the outside temperatures fluctuation, it is difficult to believe that overheating issue may rise in buildings located in such climate. Together with other weather data over 10 years, the monthly average of temperatures are shown in Figure 1 and the highest values were recorded in July-August, been lower than 26 °C (up to 21.6 °C).

Then, the rising question is how the low energy houses' characteristics, low air permeability and high thermal insulation, surely resulting in better energy performance could impact negatively on indoor climate.

Through building simulation program, the average monthly outside air temperatures for Copenhagen city was gathered. The temperature profiles of maximum, minimum, and average, shown in Figure 2, have the same profile of Figure 1 and the higher temperature values occurred on July and August equal to 22 °C.

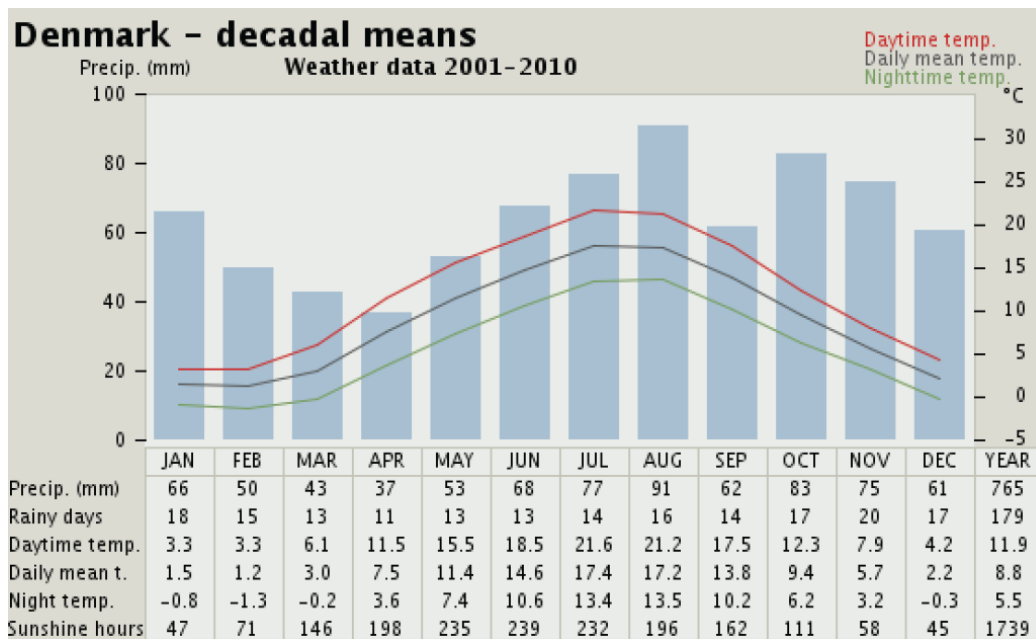

Figure 1. Average of decadal weather parameters of Denmark (2001-2010) (DMI, 2014).

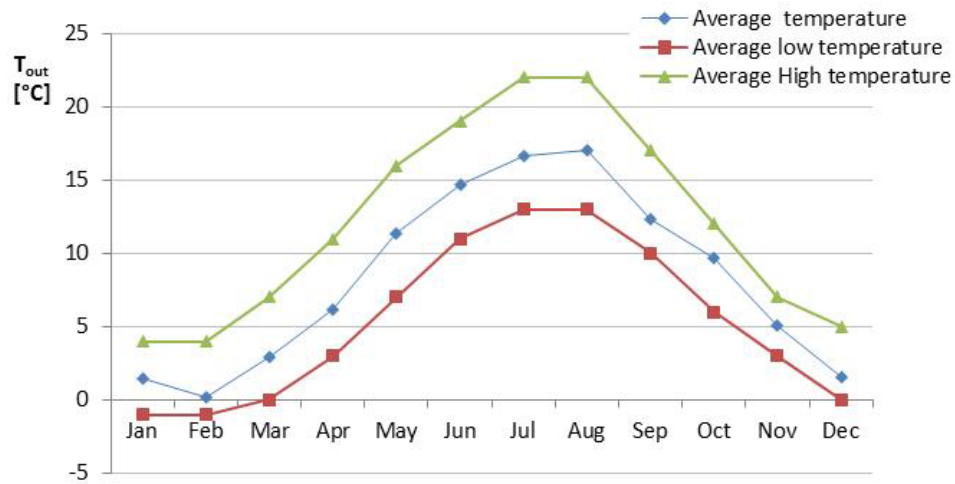

Figure 2. Monthly outside air temperatures in Copenhagen

A dynamic simulation of a typical Danish and low energy residential building, without any type of cooling systems implemented, for the climatic condition of Copenhagen was performed. The variation of the indoor temperature over all year, shown in Figure 3, reported values higher than 26 °C, over the recommended comfortable temperature for building category II (EN 15251, 2006). In particular those temperature data show that the issue of *overheating* needs to be considered in summer, when temperature could rise up 34 °C, and also in “shoulder” seasons (April, May, and September). As a consequence, cooling systems may need to be evaluated in the near future for low energy building design in order to avoid any unreasonable action that the occupants could take and which it may result in high energy consumption against the main concept of low energy buildings. So far, as prescribes by the European Directive (2010), it is necessary to exploit solutions that can grant energy saving without compromising indoor environmental quality and, for this reason, by means of dynamic simulations of Danish residential building, the effects of passive strategies, such as solar shading and natural night-time ventilation, were evaluated and analyzed.

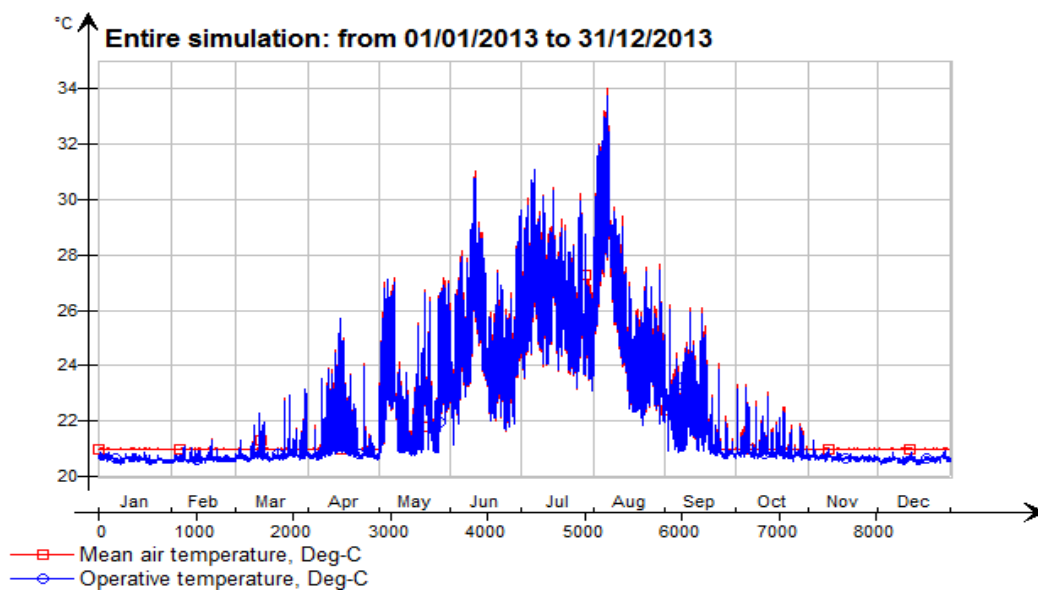

Figure 3. Operative and air temperatures hourly trend for a year of low-energy building in Copenhagen

3. Building model

A 1½-storey single-family house, earlier designed to optimize the performance of passive cooling strategies and to minimize the energy consumption in Northern European countries (Kragh et al, 2008), was chosen as building model for this study. Views of some building orientation and windows position are showed in Figure 4. A total of 23 openable windows (8 roof horizontal pivoting windows with automatic control, 8 vertical windows and 7 vertical doors), available in the marked, were positioned in the building's model. Windows sizes and positions aimed at the reduction of electric consumption for artificial light and to increase also the cooling potential of natural ventilation techniques (Kragh et al, 2008).

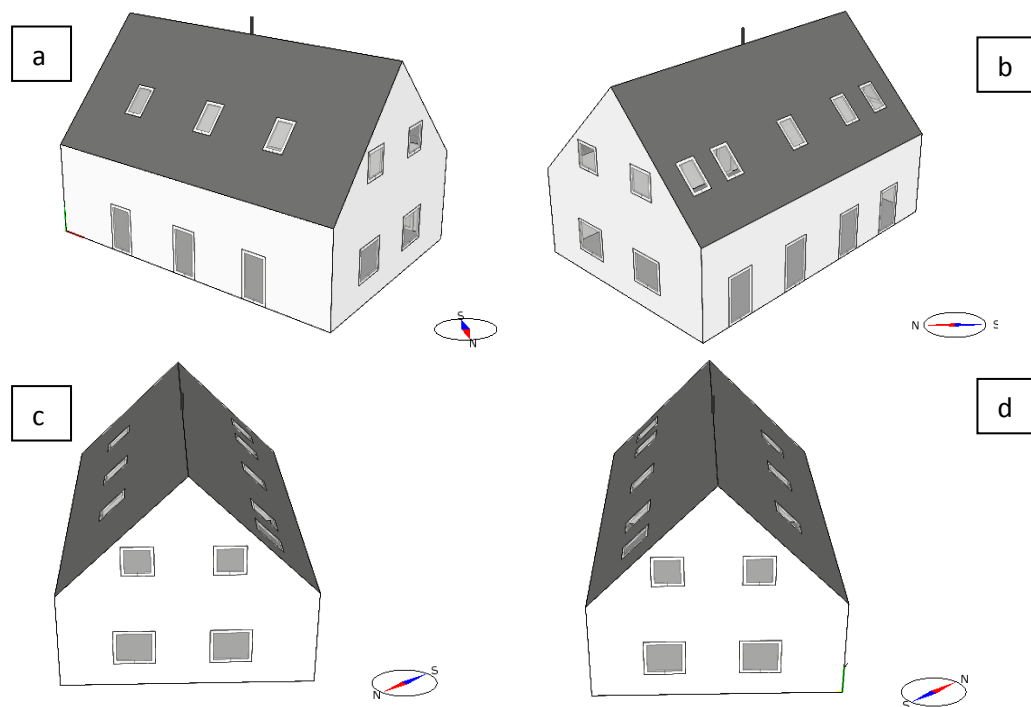

Figure 4. Visual representation of building orientation

The main characteristics of the building model are summarized in Table 1. The building is equipped with a mechanical ventilation system (M), supplying outdoor air at 16 °C minimum temperature, that guarantee 0.5 air change rate per hour during the occupancy time (not occupied from 8AM to 5PM, from Monday to Friday). A family of 4 people is assumed to be living in the building, which for the main purpose of this study is assumed to be only one zone.

Heating and cooling systems, with and without heat recovery, were integrated in the model having as set point of the indoor air temperature of 20 °C for the heating season (operating from 31st August to 6th June) and 26 °C for the activation of cooling system (operating only when needed for that particular simulated condition, later explained).

Table 1. Main characteristics of the building model

Length	Width	Floor area	Maximum height	Sloped roof	ACH	Occupants	Light	Equipment
[m]	[m]	[m ²]	[m]		[1/h]	nr.	[W/m ²]	[W/m ²]
12	8	175	7.3	45°	0.5	4	3.0	4.0

Two buildings structure, both with 20 cm of concrete thermal mass in the walls, were analyzed having different thermal property, from Building A to B, increasing the building insulation by lowering the thermal transmittance of both opaque envelope and glazed surfaces, as reported in Table 2.

Table 2. Thermal property of the two building structures

Building structure	Average U-value [W/m ² K]	
	Opaque surface	Glazed surface
A	0.30	1.127
B	0.18	0.583

4. Case studies

The Energy and Indoor Climate Visualizer (EIC Visualizer, 2012) based on IDA-ICE software was used for running all the simulations. This software was tested several times against different validation schemes. It allowed identifying the exact moment in which a change like the opening or closing of a window was occurring.

The basic building model with heating and cooling system (M_HC) was implemented with the passive strategies aiming at solving the overheating issue. Solar shading (S) and natural night ventilation (Na) were separately and coupled implemented and operated (see Table 3); so that the results obtained from the building simulation could be analyzed and compared.

Additionally, the building analyses with the implementation of the heat recovery ventilation (HRV) were studied. The air handling unit (AHU) was implemented with an air-to-air heat exchanger, with 0.85 efficiency, connecting the inlet and the outlet pipes to provide heat recovery reducing the energy consumption of the heating coil.

Table 3. Passive systems implemented in the building model

Case studies	Solar Shading	Natural Night Ventilation
M_HC	NO	NO
M_HC_S	YES	NO
M_HC_Na	NO	YES
M_HC_SNa	YES	YES

The automatic solar shading system was based on a PI controller activated when the increasing mean air temperature reaches the selected set point of 23°C. Sunshades were used in order to maintain the indoor air temperature by modulating the windows' incoming solar radiation.

A nighttime schedule was implemented for controlling the natural night ventilation. Two were the set conditions determining the automated windows opening during the whole night:

1. Indoor air temperature (t_a) above the selected threshold of 23 °C (according Pellegrini (2012));
2. Indoor air temperature (t_a) higher than outdoor temperature (t_{out}).

The nighttime control conditions were both checked at 10 p.m. when it has been assumed that the occupants go to sleep. If the recorded temperatures were satisfied ($t_a < 23$ °C and $t_a > t_{out}$) the windows were opened for the entire night, and the windows opening was controlled and modulated according the proportional controller:

- if $t_a > 23.5$ °C, the windows were fully opened;
- if 23.5 °C $< t_a < 22.5$ °C, the windows opening was modulated;
- if $t_a < 22.5$ °C, the windows were fully closed.

Moreover, indoor air quality and thermal comfort conditions were calculated and compared according to EN 15251 (2006) categories. The total energy demand/consumption, including heating, cooling, ventilation (incl. fans and heating-coil consumption), domestic hot water and auxiliary, were calculated and reported in terms of primary energy. According to EN 15203 (2006), for the electric consumption of cooling and ventilation systems, and pumps a coefficient of 2.5 has been assumed, while 1.0 was the coefficient chosen for the heating system, AHU's heating coil and domestic hot water.

In a second step of study, following the previously obtained results, few new simulations were performed taking into account some rescue for the occupants or their behavioral action as the daily windows opening.

When some drawbacks in connection with the use of natural night ventilation through the windows' opening, e.g. security reasons, raining season, and/or outside noise, were considered an alternative use of the colder outside air was evaluated. The use of the mechanical ventilation system during the night as variable air volume for bringing inside the outside air with the support only of a fan, and so the increase of air change rate was considered. Then the energy consumption and the resulting indoor temperatures for providing thermal comfort were calculated and compared between the windows' natural ventilation (Na) and the mechanical ventilation implemented by the night use for bringing inside the colder outside air (MNa).

To make comparable the two simulation models using the outside air for cooling, the same setting of the night natural ventilation (Na) earlier explained, were adopted to the mechanical ventilation system. Therefore, when at 10 p.m. the inside temperature is higher than 23°C the supply air flow was automatically increased up to 1 ach.

The two models were applied and compared for the period of time from May 1th till September 30th.

5. Results

The simulated results evaluating two near zero energy buildings show that, by improving the insulation and airtightness of the building, from structure A to B, the total energy demand decrease from 128 kWh/m² per year to 96 kWh/m² per year, resulting in 21% of total energy saving (see Table 4). A further 21% and 27%, for the same building's structure A and B respectively, was saved when the heat recovery unit was implemented in the systems, of which 70-73% of energy savings were achieved by the ventilation system.

Looking more in details through the energy demand of different systems, it can be noted that the heating demand went from 58 to 18 kWh/m² per year resulting in 69% of energy saving on heating; while, on the other hand, the increased insulation and air tightness (building B) caused an increase of cooling need (up to 60%), bringing the energy demand for cooling from 13.3 to 21.4 kWh/m² per year (see Figure 5). It indicates the rising of overheating issue, with expected indoor temperatures distribution reaching even 34 °C and, as shown in Figure 6, with an extended overheating period till the end of September.

Those results suggested that actions need to be taken in order to avoid future increase of energy consumption, to control the energy use for satisfying the cooling demand, and to maintain indoor thermal comfort conditions.

Clearly the combination of the combined passive strategies, solar shading and natural night ventilation, applied in the simulated model with the heat recovery unit (M_HC_SNa_HRV) were the best energy saving applications. Those strategies applied to the higher insulated building B resulted in only 47 kWh/m² year of energy demand (see Table 1) and permitted to reach the goal of zero energy cooling demand (see Figure 5b).

Can also be noted that the application of only one of the two passive strategies helped substantially on decreasing the cooling demand, to 0.6 or 0.4 kWh/m² year with the solar shading, and to 7.1 or 0.1 kWh/m² year with the night-time ventilation (see Figure 5), which is very low but still accounted.

However, the performed simulations showed that with higher building insulation (building structure B) and ventilation with heat recovery, the only use of natural night ventilation permit to achieve the lowest total energy consumption (46.3 kWh/m² year) having only 0.1 kWh/m² year of cooling demand.

Table 1 Total energy demand of two buildings structure

CASE STUDIES	Total energy demand [kWh/m ² year]		Energy Savings [%]
	Structure A	Structure B	From A to B
M_HC	127.7	95.9	24
M_HC_HRV	101.3	69.5	31
M_HC_S	116.4	75.0	36
M_HC_S_HRV	90	48.6	46
M_HC_Na	118.7	70.5	41
M_HC_Na_HRV	93.8	46.3	51
M_HC_SNa	115.1	72.4	37
M_HC_SNa_HRV	89	46.9	47

a) Building structure A

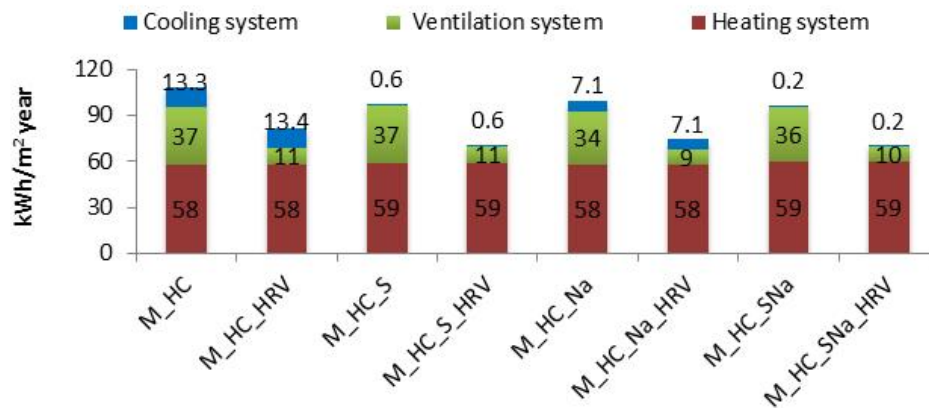

b) Building structure B

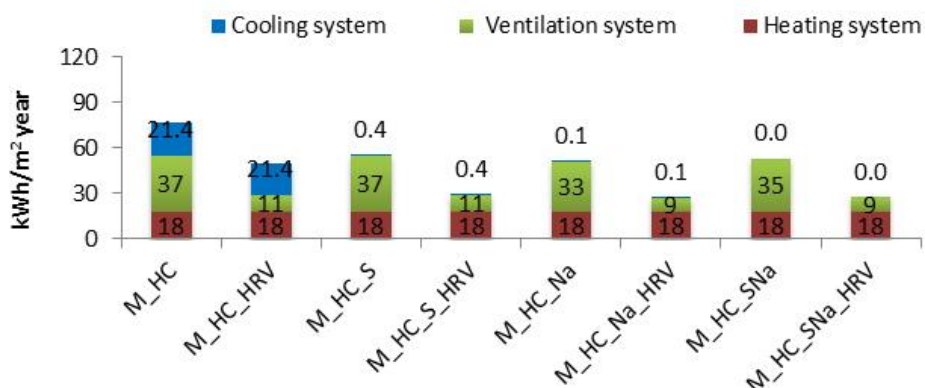

Figure 5. Energy demand divided by the three systems for M_HC_HRV and M_HC_SNa_HRV models for both structure A and B.

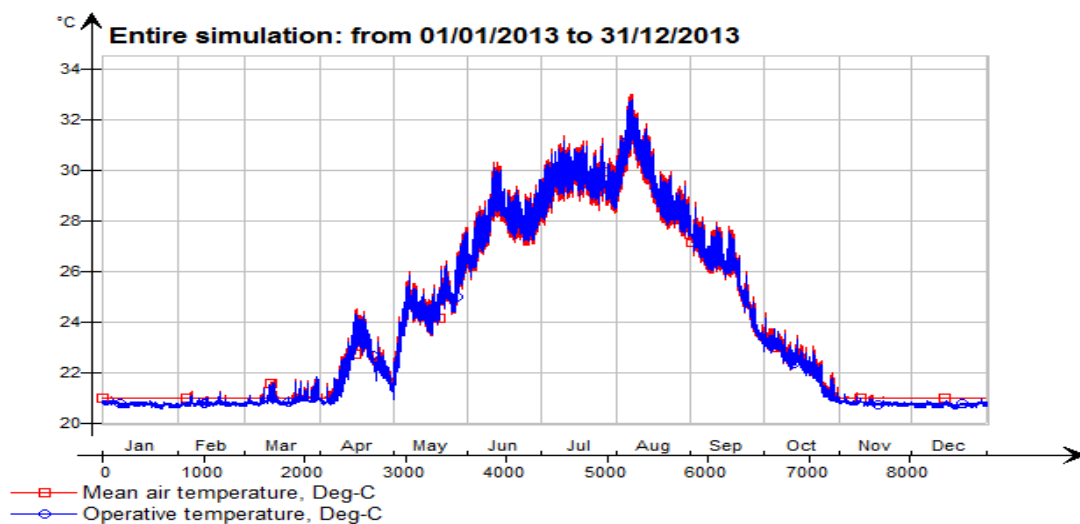
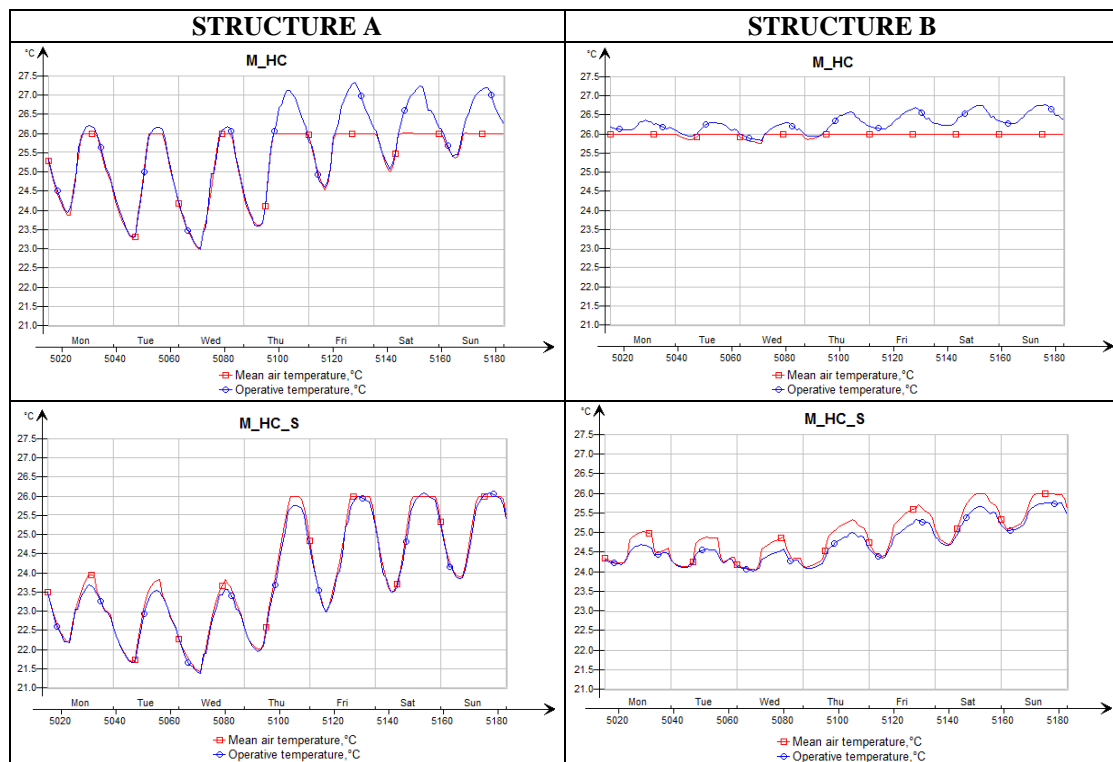

Figure 6. Indoor temperature variation in highly insulated building structure B.

The performance of the two buildings structure with applied different type of simulated systems was again evaluated according the indoor temperatures variation.

In Figure 7 are shown air and operative temperatures variation of one of the warmest week of the year (end of July and beginning of August). Among the two building's structure it can be observed higher day-night temperatures' variation, in the range of 3.5 °C - 4.5 °C, in building A (see Figure 7 left side), while the results of the higher insulation used in the building envelope B (Figure 7 right side) turned in a more constant air temperature, with an amplitude variation of 0.5 °C -1.5 °C, and an increased operative temperature due to the entrapped heat from solar radiation through the wider windows surface. The capacity of building B to achieve less temperature variation, with operative temperature below 26 °C, was achieved when the solar shading strategy was applied (M_HC_S), which it did not comply with the best results in term of energy saving observed in M_HC_Na simulation.

Finally, by combining the results obtained when observing the indoor operative temperature and the lower energy demand, the desired building model resulted to be the one with integrated both passive strategies (M_HC_SNa_HRV). However, when lowering the temperature during the night it not causing any thermal discomfort, the night-time cooling of indoor air and indoor building structures (precooled building thermal mass for the benefit of cooling on the following day) it can be freely performed by the natural night ventilation (model M_HC_Na) which can also contribute to a better indoor air quality.



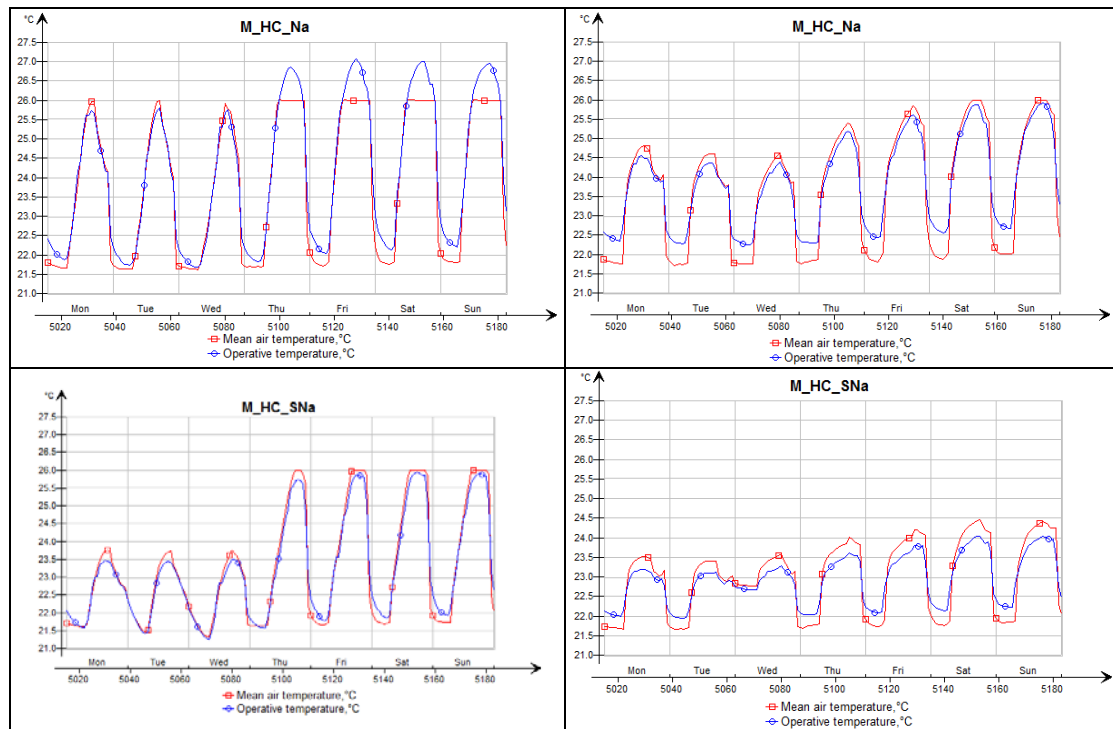

Figure 7. Air and operative temperature variation of all study cases of building A (on the left) and building B (on the right)

When the solar shading strategy is applied, alone or combined with the use of nighttime natural ventilation, the percentage of the windows coverage resulted from the simulations is reported in table 5. The use of the shading resulted more dominant for the more insulated building B, in particular when it was considered as the only cooling strategy. Those values should be considered important for countries like Denmark with low sunshine hours, where it can make the habitants reluctant on the use of the solar shading strategy looking for alternative cooling systems.

Table 5. Percentage of windows coverage when solar shading strategies are applied

Case studies	Solar shading coverage [%]					
	Structure A			Structure B		
	<50%	>50%	100%	<50%	>50%	100%
M_HC_S	84	16	6	68	32	16
M_HC_SNa	87	13	4	82	18	1

If the natural night ventilation was considered as cooling strategy, alone or combined with the use of solar shading, the period of its working time was estimated and, as reported in table 6. It is evident that, to avoid overheating, the nighttime ventilation should also be applied during the mid-seasons, starting already from April. Besides, to cool the higher insulated building, higher air change rate (ACH) needed to be guarantee which could result in higher indoor air velocities.

Table 5. Natural night ventilation parameters

Case studies	Period		ACH [1/h]	
	Structure A	Structure B	Structure A	Structure B
M_HC_Na	Apr 12 th -Sept 17 th	Apr 14 th - Sept 19 th	1.3	3.4
M_HC_SNa	May 4 th - Aug 29 th	May 5 th - Sept 16 th	1.3	2

6. NIGHT VENTILATION: NATURAL vs MECHANICAL

The use of night-time ventilation for cooling was more analyzed and, at the same time, due to some drawbacks connected to the windows opening, it was directed on bringing the outside colder air inside through the mechanical ventilation system.

The possibility of using the nighttime cooling potential by an active strategy (mechanically assisted) instead of a passive one (windows opening) rise the need of evaluating the impact on the indoor environment and on the energy demand.

Referring to a period of 4 months (May-September), the simulated model with nighttime ventilation through windows opening (Na) was implemented by the only use of the mechanical ventilation with higher air change rate (MNa) and applied at building B higher insulated. As expected, results showed slightly higher energy demand for ventilation with 11.5 kWh/m² year in MNa-model instead of 9.4 kWh/m² year with Na-model, having both satisfying the cooling demand that was nullified.

The provided air change rates at nighttime through those simulated models are shown in Table 7, having a lower average 0.8 h⁻¹ in MNa than 1.8 h⁻¹ in Na model.

Table 7. Night-time air change rate when mechanical assisted (MNa) or only natural (Na) ventilations were simulated

Nighttime ventilation model	ACH [h ⁻¹]		
	average	maximum	minimum
MNa	0.8	1.1	0.6
Na	1.8	18.5	0.6

The operative temperatures variations resulted most of the time higher when the active ventilative strategy (MNa) was applied than the passive one (Na). The temperature difference could reach 1.5-2 °C as shown in the temperature variation of August reported in Figure 8. The temperatures difference was attributed to the effect of higher air change rate with the windows opens which increased the utilization of building thermal mass.

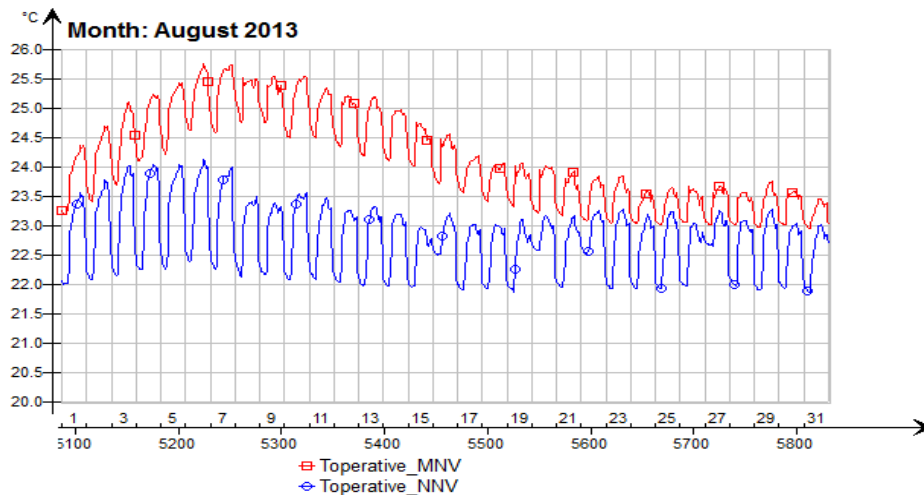

Figure 8. Operative temperature variation for MNa and Na simulated models in August

7. CONCLUSION

Moving towards zero energy buildings make the building construction more and more airtight and higher insulated. In this work a model of a residential low energy building has been considered and implemented. Simulations of two buildings type, located in the cold climate of Copenhagen, showed an additional 69% of energy saved on heating, while it increased the energy demand for cooling of 21.4 kWh/m² year. This result highlight the incoming overheating issue and indoor thermal discomfort, which, associated to the increasing outside temperature from climate change, may only increase and, if not controlled, end in higher building energy consumption.

The passive cooling strategies, as solar shading and nighttime ventilation, separately and coupled, and the heat recovery ventilation were implemented in the simulated buildings' model. Results showed the lowest energy consumption (46.3 kWh/m² year) occurred when the only night-time natural ventilation, in the higher insulated building, was applied. However, the best solution in terms of energy demand and indoor environmental quality was the model (M_HC_SNa_HRV) with both passive strategies application in which the cooling demand was satisfied with environmental/energy friendly solutions.

The performed simulations confirmed the higher importance of solar shading application for the highly insulated buildings in summer time, which may not be the well accepted by the buildings' occupants. As consequence, the use of night-time cooling ventilation was more focused. The use of the outside colder air was studied under two different conditions: when introduced inside by the windows opening or through the mechanical ventilation system supported only by a fan having higher air change rate (up to 1 h⁻¹). There was a small increase of energy demand due to the fan operation which it didn't impact on the cooling need, in any case satisfied.

The increased air change during the night through the mechanical system can help to eliminate some drawbacks (e.g. security, rainy nights, noise, etc.) and, combined with the higher insulated building, resulted in a constant indoor temperature daily kept just below 26 °C. However, the natural night ventilation through the windows opening resulted in a constant and desired indoor temperature of 24 °C requested in previous studies.

References

- Danish Meteorological Institute (DMI), 2014. *Denmark Climate Reports*, 2014. Available on line at: www.dmi.dk
- EIC Visualizer, 2012. Available online at: http://eic.velux.com/eic_visualizer/
- EN 15251:2006 *Indoor environmental input parameters for design and assessment of energy performance of buildings-addressing indoor quality, thermal environment, lighting and acoustics*.
- EUDP, 2010. The Directive 2010/31/EU of the European Parliament and the Council of 19 May 2010 on the Energy performance of buildings, Official Journal of the European Union, 53, 2010.
- Janson, U., 2010. *Passive House in Sweden-From design to evaluation of four demonstration projects*. PhD Thesis, Division of Energy and Building Design, Department of Architecture and Built Environment, Lund University, Faculty of Engineering LHT.
- Kragh, J., Laustsen, B., Svedensen, S., 2008. *Proposal for Energy Rating System of Windows in EU*. DTU Scientific-Report, Department of Civil Engineering, 2008.
- Larsen, T.S., Jensen, R.S., Daniels, O.. *The comfort Houses-Measurements analysis of the indoor environment and energy consumption in 8 passive House 2008-2011*. Department of Civil Engineering Aalborg University, January 2012
- Orme, M., Palmer, J., Irving, S., 2003. *Control of Overheating in well-insulated Housing*. Building sustainability: values and profit. Available online at: <http://www.cibse.org/pdfs/7borme.pdf>
- Pearlmutter, D., Meir, I., 1995. Assessing the climatic implication of lightweight housing in a peripheral arid region. *Building and Environment*, 30 (3), 441-451, 1995
- Pellegrini, T., Foldbjerg, P., Olesen, B.W., 2012. Improvement of summer comfort by passive cooling with increased ventilation and night cooling. In: *The 33rd AIVC and 2nd TightVent Conference - Optimising Ventilative Cooling and Airtightness for [Nearly] Zero-Energy Buildings, IAQ and Comfort*, Copenhagen, Denmark, 10-11 October
- prEN 15203/15315:2006. *Energy performance of buildings. Overall energy use, CO2 emissions and definition of energy ratings*

Summer Thermal Comfort in New and Old Apartment Buildings

Mikk Maivel¹; Jarek Kurnitski¹; Targo Kalamees¹

¹ Tallinn University of Technology, Ehitajate tee 5, 19086, Tallinn, Estonia

mikk.maivel@ttu.ee

Abstract

In Nordic countries overheating and cooling systems have not been the issue in apartment buildings. Historically and even in the beginning of 2000 there were not indicated such problems. New architecture with larger windows and strict energy performance requirements has changed the situation. If adequate measures are not used, new buildings may be easily overheated. In the design this is a question of temperature simulations, and application of mostly passive design measures which might be needed to be supported with installation of active cooling system in some cases to fulfil minimum requirements for energy performance and thermal comfort. Even revised EPBD increase the role of overheating problems and suggest using passive cooling technologies like shadings. This study conducted field measurements in more than 100 Estonian apartments. Results show that the overheating occurs in modern buildings where average room temperature was about 1°C higher than in old buildings. According to criterion of weighted excess degree hours over +27 °C, there was no overheating in old apartment buildings, but in new apartment buildings the criterion was exceeded in 13.7% of apartments in 5 week period. The paper reports field measurements and analyse ventilation, orientation etc. effect on overheating.

Keywords: thermal comfort, indoor climate, overheating problem, apartment building

1. Introduction

Indoor climate's quality influence our everyday habits and have an substantial role for our health. According to Seppänen studies in Nordic climate people stays approximately 90% of time in artificial environment [1]. In Estonia approximately 63% of residents live in apartments. During last five years extensive analyses were conducted for Estonian housing stock. This paper includes the basic results and findings from two different investigations about housing groups: apartment buildings composed from prefabricated concrete elements [2] and recently built modern apartment buildings [3]. The aim of this paper is to analyse and compare new apartment buildings with soviet era building stock regarding thermal comfort. Paper focus on overheating effect in summer time which causes discomfort especially in recently built apartments. Some passive measures are analysed to avoid overheating in apartments. Thermal comfort analyses are based on actual temperature measurements.

2. Methods

2.1 Studied buildings

Indoor climate was studied in 100 apartments in 48 buildings (Figure 1). 39 apartments where built during the 1960-1990 and 61 during 2001-2010. All of them were in private ownership. From each building approximately two apartments were

selected to be studied, mostly from the upper and the bottom floor. Apartments had usually two or three rooms with three inhabitants.



Figure 1 Examples of analysed building (old (left) and new (right)).

2.1.1 Apartment buildings composed of prefabricated concrete elements

Apartments from soviet era have basically three different main types which could have different renovated stage (e.g. partly insulated, new windows etc.). Typically, the studied dwellings had natural passive stack ventilation (73% of studied buildings). In some apartments kitchens were supplied with a hood. In all of the dwellings studied, windows could be opened for airing purposes. Though mechanical ventilation has been the standard installation in new dwellings in Estonia during the last decade, old apartment buildings have preserved natural ventilation due to the complexity of the ventilation renovation.

2.1.2 Modern apartment buildings

Recently built apartments were all with different typology. Buildings were selected with different external wall structures (Figure 2, left) and ventilation systems (Figure 2, right). The selection could represent an average of recently built Estonian apartment buildings.

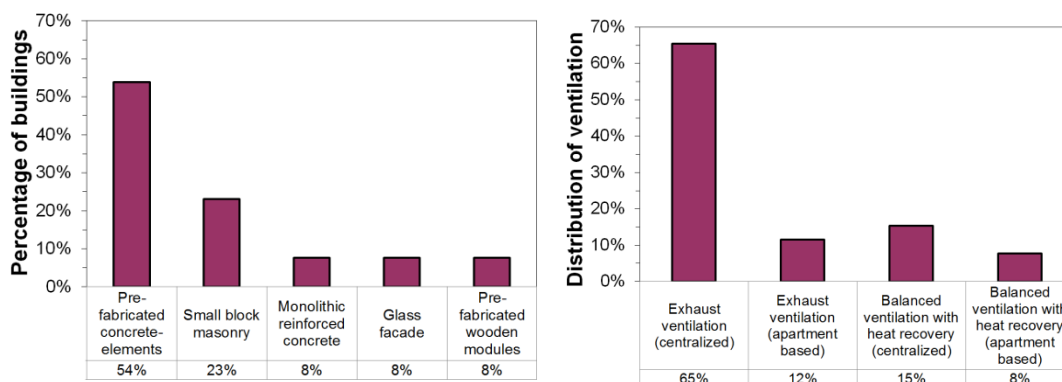

Figure 2 Distribution of studied apartments according to external wall type (left) and ventilation system (right).

2.2 Measurement methods

The values of temperature were measured with data loggers at 1 hour intervals over a 1 year period. The data loggers were located on the partitioning walls mainly in master bedrooms.

Outdoor temperature was obtained from the nearest weather station.

2.3 Assessment of indoor climate

Indoor thermal conditions in the studied apartments were assessed based on the target values from the standards [4], [5]. The II indoor climate category (normal level of expectation, for new buildings: PPD \approx <10%) and the III indoor climate category (acceptable, moderate level of expectation, for existing buildings: PPD \approx <15%) were selected for the comparison.

EPBD directive [6] sets mandatory for member states to launch appropriate legislation for new buildings and buildings under major renovations to control and avoid possible overheating. Estonian energy performance of minimum requirements [7] sets as a criteria in apartment buildings 150°C·h over indoor temperature +27°C during the period of 1st. June to 31 august. It is in the same level as suggested by Olesen and Parsons [8] and van der Linden et al. [9] that an acceptable annual weighting time of 100–150 hours may be used as a standard in office buildings.

2.4 Analysing period

Field measurements were carried out in different years (for old apartments 2008 and for new 2011). Overheating was typically investigated for the summer period starting 1st June to 31 August. To make results comparable, the similar weeks of outdoor climate were selected. Average outdoor temperature in 2011 summer was 14.3°C compared to 2008 13.2°C (Figure 3).

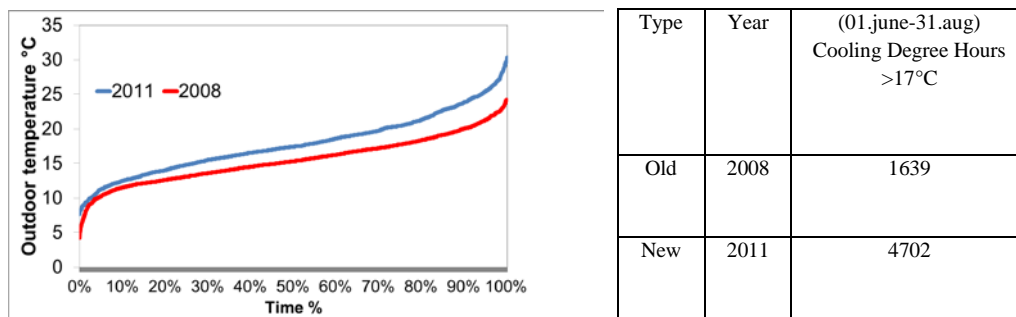

Figure 3 Comparison of 2008 and 2011 summer.

To find the weeks with similar outdoor temperature and solar radiation, two summers were compared week by week. (Figure 4, 5)

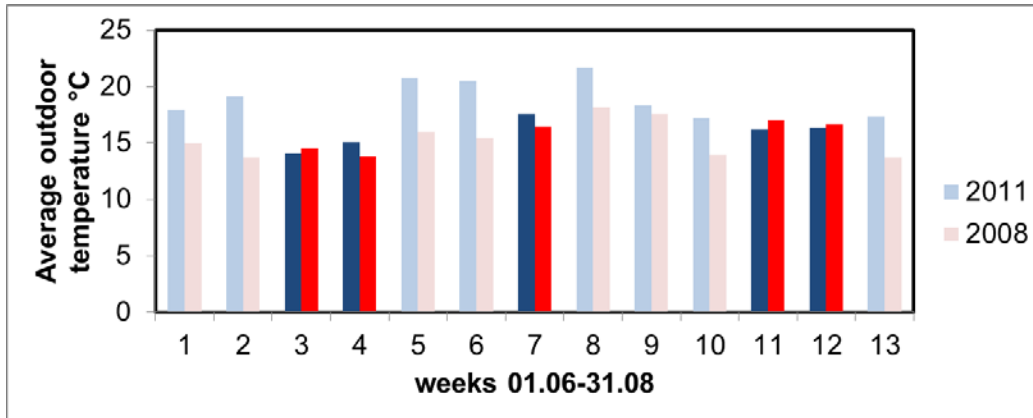

Figure 4 Comparison of 2008 and 2011 summer outdoor temperature.

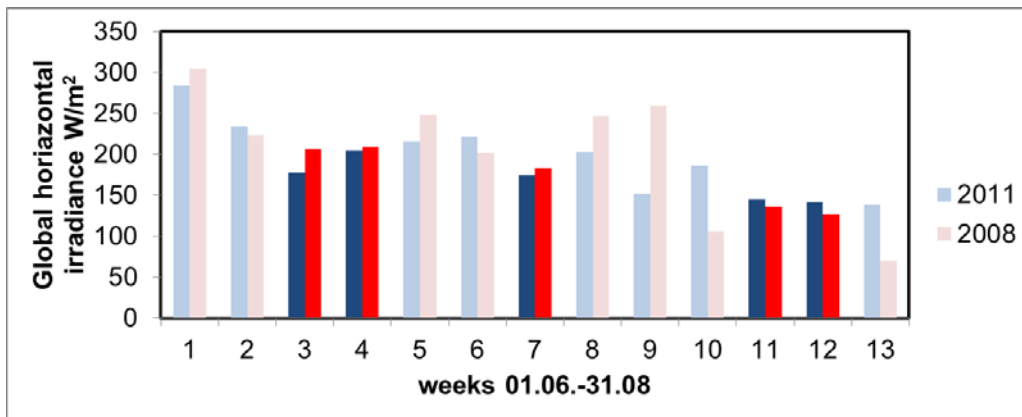

Figure 5 Comparison of 2008 and 2011 summer global irradiance.

Selected weeks are shown as a bold columns. Analyses were based on 5 selected weeks (week no. 3,4,7,11 and 12) during which the outdoor temperature and global irradiance were almost the same as can be seen from duration curves in Figure 6.

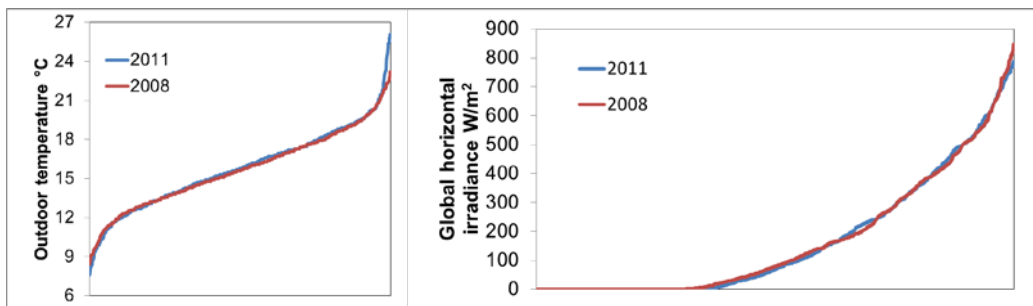

Figure 6 Comparison of 2008 and 2011 summer in selected 5 week period. Duration curve of outdoor temperature (left) and solar radiation (right).

Because of very different summers, the results calculated for three summer months provided biased comparison between old and new buildings: Figure 7 shows that 65% of new apartments exceeded the limit criteria +27°C in the summer of 2011 compared to 5.1% of old apartments exceeded the limit in 2008.

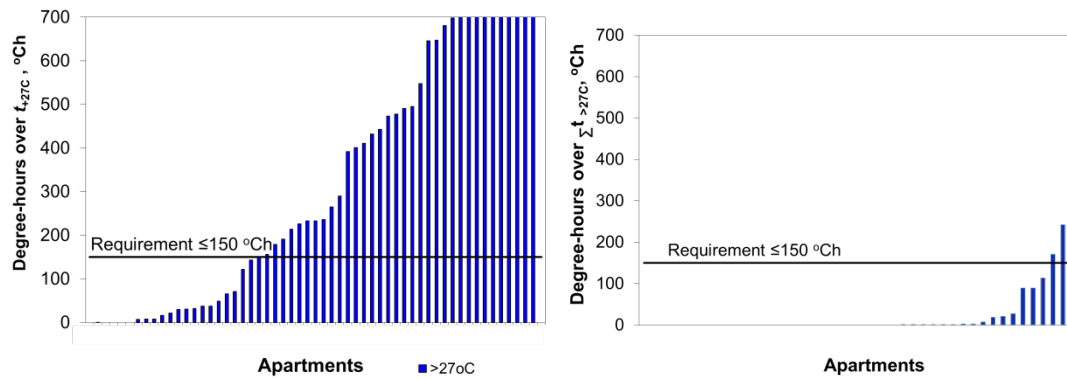

Figure 7 The amount of weighted excess degree hours over +27 °C in three summer months in new (left) compared to old (right) – the results do not provide objective comparison between building types because outdoor temperature was much higher in the case of left figure.

3. Results

The results reported in this chapter are from selected 5 weeks period, which enables objective comparison between old and new apartment buildings.

3.1. Ventilation impact on possible overheating.

Ventilation has a substantial role for indoor quality. As reported in previous section analysed building has different ventilation systems (Figure 2). Normally old buildings have natural (passive stack) ventilation and summer time air change occurred mostly by airing the windows. Stack ventilation during summer is minimum due to small difference of indoor and outdoor temperatures.

New buildings have normally more advanced ventilation systems (Figure 3).

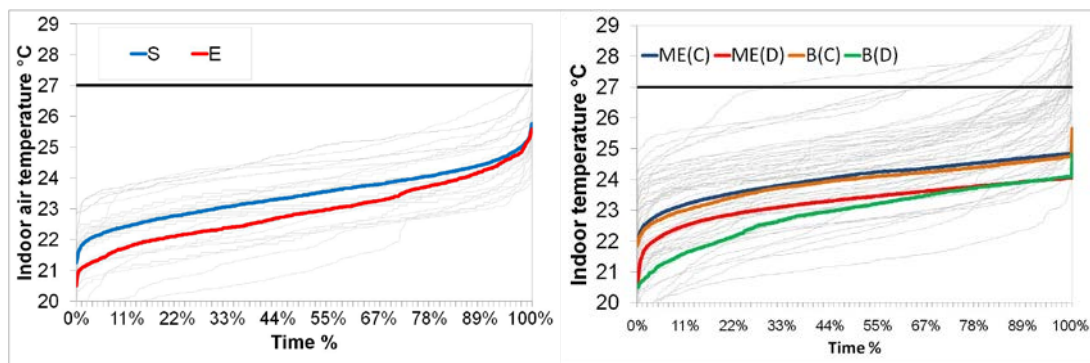

Figure 8 ventilation effect on indoor temperature in old buildings(left) and new buildings (right) (S – passive stack ventilation; E – apartment with mechanical exhaust ventilation; ME(C) – centralized exhaust ventilation; ME(D) – apartment based exhaust ventilation; B(C) – centralized balanced ventilation with heat recovery; B(D) – apartment based balanced ventilation with heat recovery).

Figure 8 shows that old apartments with mechanical ventilation have a slightly lower indoor temperature (average with natural stack ventilation is 23.4°C (st.dev. 0.79°C) compared to 22.9°C (st.dev. 0.97°C with mechanical exhaust ventilation).

In new buildings apartment ventilation units have ensured approximately 0.8 °C lower indoor temperature than centralized systems. With apartment exhaust ventilation units, average indoor temperature was 23.2°C (st.dev. 0.59°C) compared

to centralized exhaust ventilation 24.01°C (st.dev. 0.60°C). The same tendency was in heat recovery systems where apartment supply and extract ventilation units with heat recovery showed average indoor temperature of 22.9°C (st.dev. 0.90°C) and centralized balanced ventilation system 23.89°C (st.dev. 0.61°C).

3.2 Cooling impact on possible overheating.

One solution to avoid overheating is to install active cooling system, Figure 9. Active cooling systems are expensive and obviously add extra energy for cooling making it difficult to fulfil minimum requirements for energy performance [10]. Only one building in this study had an active cooling system. This building was high rise (25 storeys) and with high-share of glass façade. Rooms with active cooling had an average indoor temperature during 5 week time 23.1°C (st.dev 1.25°C) and indoor temperature in similar building without active cooling was 24.62°C (st.dev 1.06°C).

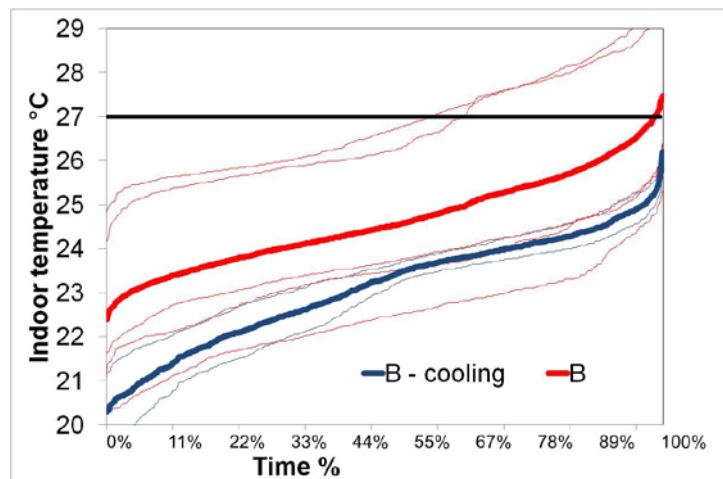

Figure 9 Cooling effect for indoor temperature in new building (B-cooling – balanced ventilation with cooling; B – balanced ventilation).

3.3. Window area and orientation impact on possible overheating.

New buildings have higher-share of windows than old ones. In new buildings window area per room floor area where in the range of 0.18 to 0.45 (average 0.25) and in old buildings between 0.1 to 0.21 (average 0.15), (Figure 10).

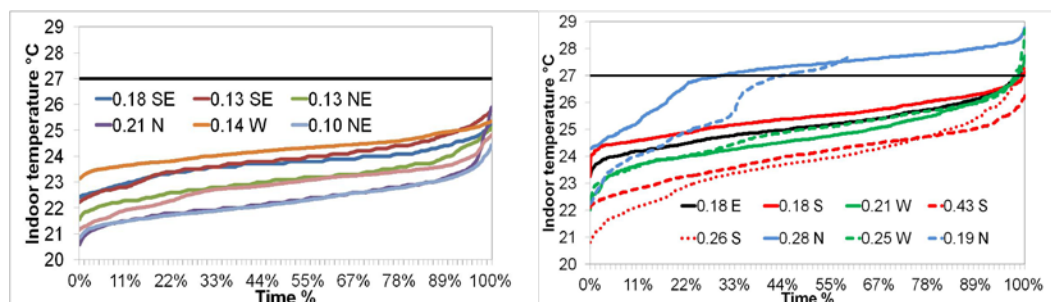

Figure 10 Indoor temperatures as a function of window to floor ratio and orientation, old buildings in the left and new buildings in the right. Code: 0.18 SE means window to floor ration 0.18 and SE orientation of windows (N-north, SE – South-East, NE – north east, W-west).

Some of results in Figure 10 are logical, but some ones are not. Possible explanation are many confounding factors which are not possible to take into account in such field measurements (shadings by balconies, and other buildings, differences in window airing and internal heat gains etc.).

3.4 Indoor temperature as a function of the outdoor temperature.

Hourly average indoor temperatures in all new apartments were by about +1°C higher than in old apartments (Figure 11).

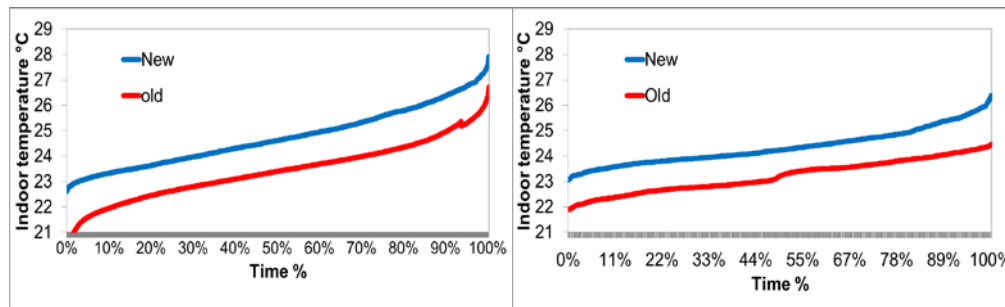

Figure 11 Comparison of new and old apartment indoor temperature during 5 week period (right), 3 month period (left)).

To see the outdoor temperature dependency, from each room at each hourly outdoor air temperature (the step of 1°C was used), all hourly daily indoor temperature values were plotted, Figure 12. Each individual thin solid curve shows the average indoor temperature hourly values at the corresponding outdoor temperature value in one apartment. The dotted curve represents the average curve from all the apartments

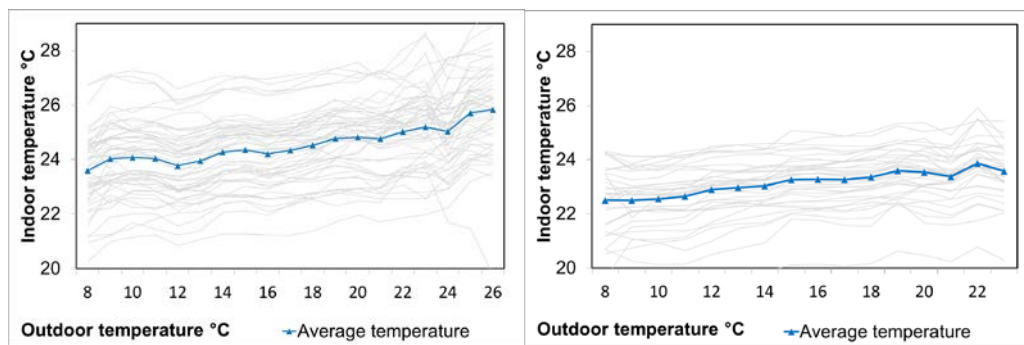

Figure 12 Indoor temperature as a function of outdoor temperature in new (left) and old (right) apartments, the results are reported from three summer months.

3.5 Overheating

To analyse the overheating, the amount of weighted excess degree hours over +27 °C was calculated for selected 5 weeks period. Because the Estonian criterion of 150 °Ch applies for three summer months (13 weeks), the results shown in Figure 13 need to be multiplied with factor of $13/5=2.6$ in order to take into account the effect of shorter analysing period. Results show no overheating in old apartment buildings, but in new apartment buildings the criterion of $150/2.6$ °Ch was exceeded in 13.7% of apartments.

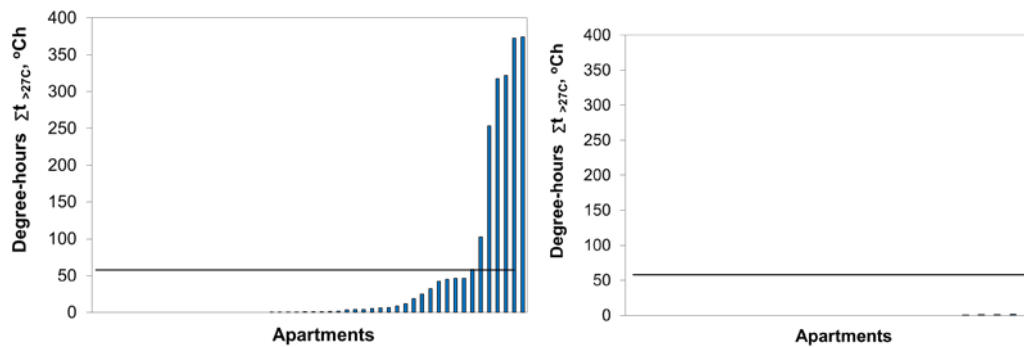

Figure 13 The amount of weighted excess degree hours over +27 °C in five summer week in new (left) compared to old (right).

4. Conclusion

The possible overheating effect in recently built apartment buildings compared with old prefabricated concrete apartment buildings was analysed in this study. The results show that in new Estonian apartment buildings average room temperatures were by about 1°C higher than in old buildings. Larger windows partially explained higher temperatures, but the correlation was weak and sometimes inconsistent because of many confounding factors not possible to control in this type of field measurements. Further analyses are needed to explain the reasons of significantly higher temperature in new apartments. High room temperatures indicate that more attention should be paid to passive solar shading and airing measures. According to criterion of weighted excess degree hours over +27 °C, there was no overheating in old apartment buildings, but in new apartment buildings the criterion was exceeded in 13.7% of apartments in 5 week period.

Acknowledgment

The research was supported by the Estonian Research Council, with Institutional research funding grant IUT1–15, and with a grant of the European Union, the European Social Fund, Mobilitas grant No MTT74.

References

- [1] Seppänen, O; Seppänen, M. (1998) Hoone sisekliima kujundamine". Tallinn Koolibri (*in Estonian*).
- [1] Kalamees, T.; Kõiv, T-A.; Arumägi, E.; Ilomets, S. (2010). Indoor temperature and humidity conditions in Estonian old multi-storey apartment buildings composed of prefabricated concrete elements. Proceedings of Clima2010 10th Rehva World Congress "Sustainable Energy Use in Buildings": Clima2010 10th Rehva World Congress "Sustainable Energy Use in Buildings", Antalya, 9-12.05.2010. (8).[Rowman & Littlefield]; Lexington Books
- [2] Kalamees, T.; Ilomets, S.; Kuusk, K.; Paap, L. (2013). Indoor Temperature and Humidity Conditions in Modern Estonian Apartment Buildings. *In: Proceedings of 11th REHVA World Congress and the 8th International Conference on Indoor Air Quality, Ventilation and Energy Conservation in Buildings: Prague, Czech Republic, on June 16 – 19*. Elsevier, 2013.
- [3] CR 1752 (1998) Ventilation for Buildings: Design Criteria for the Indoor Environment. CEN, Brussels.
- [4] EN-15251. 2007. Indoor environmental input parameters for design and assessment of energy performance of buildings-addressing indoor air quality, thermal environment, lighting and acoustics. CEN.
- [5] EN ISO 7730 Ergonomics of the thermal environment. Analytical determination and interpretation of thermal comfort using calculation of the PMV and PPD indices and local thermal comfort criteria
- [6] Directive 2010/31/EU of the European Parliament and of the Council of 19 May 2010 on the energy performance of buildings.
- [7] Ministry of Economic Affairs and Communication, Regulation No 68 (2013) ..Minimum requirements for energy performance".
- [8] Olesen, B.W., Parsons, K.C. (2002) Introduction to thermal comfort standards and to the proposed new version of EN ISO 7730, *Energy and Buildings*, 34, 537-548.
- [9] Van der Linden, A.C, Boerstra, A.C., Raue, A.K., Kurvers S.R. (2002) Thermal indoor climate building performance characterized by human comfort response, *Energy and Buildings*, 34, 737-744.
- [10] Kalamees, T; Ilomets, S; Liias, R; Raado, L-M; Kuusk, K; Maivel, M; Ründva, M; Klõšeiko, P; Liho, E; Paap, L; Mikola, A; Seinre, E; Lill, I; Soekov, E; Paadam, K; Ojamäe, L; Kallavus, U; Mikli, L; Kõiv, T-A. (2012). Eesti eluasemefondi ehitustehniline seisukord – ajavahemikul 1990–2010 kasutusele võetud korterelamud. (*in Estonian*)

A coupled summer thermal comfort and indoor air quality model of urban high-rise housing

Anna Mavrogianni¹, Jonathon Taylor¹, Chrysoula Thoua¹, Michael Davies¹, John Kolm-Murray²

1 The Bartlett School of Graduate Studies, University College London, Central House, 14 Upper Woburn Place, London WC1H 0NN, UK

2 London Borough of Islington Council, 1 Cottage Road, London N7 8PT

Abstract

The synergistic effects between summertime ventilation behaviour, indoor temperature and air pollutant concentration in relation to energy retrofit and climate change have been under-investigated to date. This paper explores such interactions in a social housing setting. The case study flat is located on a mid-floor of a high-rise council tower block in central London. Dwellings of this type are likely to be occupied by vulnerable individuals (elderly people or people suffering from ill health or mobility impairment). Monitoring and modelling of the thermal and airflow performance of the case study suggests that its occupants may be already exposed to some degree of overheating. Whilst improved natural ventilation strategies may reduce such risks to a certain extent, their potential may be limited in the future due to high external temperatures and the undesired ingress of outdoor pollutants, thus highlighting the need for further adaptation measures.

Keywords: comfort, overheating, indoor air quality, climate change, high-rise housing

1 Introduction

1.1 Comfort and health impacts of urban warming trends

Anthropogenic climate change is predicted to increase the frequency and severity of heatwave events (Beniston et al, 2007). Whilst developing countries are likely to be harder hit by global warming effects (The World Bank 2008), the low income groups of inner cities in temperate climates are also vulnerable to extreme weather events (IPCC 2007). As population exposure to unprecedentedly high temperatures is becoming more frequent, heat related morbidity and mortality is an increasing concern in previously heating dominated climates, as highlighted, for example, by the NHS Heatwave Plan for England (NHS England and PHE 2013). In terms of mortality, the 2003 heatwave resulted in an estimated 70,000 excess deaths across Europe (Robine et al, 2007), of which approximately 2,000 occurred in the UK (Johnson et al, 2005) and around 600 in London alone (MOL 2007). Summer temperatures are projected to increase by up to 4 °C in the South of England by the 2080s under a Medium Emissions scenario (Jenkins et al, 2009). Average winter air temperatures are also likely to rise by between 2 and 3 °C, with slightly higher increases projected for the South East of England. Numerous studies and programmes have investigated the impacts of climate change in the UK; for example, the DEFRA National Adaptation Programme which outlined the UK Government's plans for becoming more climate ready (DEFRA 2013).

It has been indicated by a number of studies that heat-related mortality risk increases in urban environments due to the exacerbation of hot spells by the urban heat island phenomenon (Kovats and Kristie 2006, Hajat et al, 2007), i.e. the inadvertent local urban climate modification caused by urbanisation processes that result in a systematic positive temperature differential between urban and surrounding rural areas (Oke 1982). This is of particular importance as future urban growth and human response to heatwaves, for example the installation of air conditioning and associated waste heat to urban canyons, could potentially lead to a further intensification of warming trends (Gupta and Gregg 2012, Peacock et al, 2010). Whilst the use of active cooling systems could be beneficial for human health in the short term (Keatinge and Donaldson 2004), these will lead to negative environmental and financial consequences for households. Active cooling equipment in residential environments is currently rare in the UK, however, it is expected that a large percentage of household spaces in England will be equipped with mechanical cooling systems by 2030 based on future climate change projections (Collins et al, 2010). It is hence essential to reverse this trend through the adoption of alternative passive adaptation solutions across the UK housing stock.

Furthermore, although there is a plethora of modelling and monitoring studies assessing the impact of energy efficient retrofit interventions and climate change-induced rises in ambient temperature on indoor overheating and air quality, these issues are usually examined in isolation and synergistic effects between summertime ventilation behaviour, indoor temperature and air pollutant concentration have been under-investigated to date.

Heat vulnerability comprises of the following factors: a) *sensitivity*, b) *exposure* and c) *inability to adapt or access treatment*. There are a number of epidemiological studies investigating individual determinant factors for heatwave sensitivity and inability to adapt, summarised in a literature review by Kovats and Hajat (2008). Such factors include age (elderly above 65 and children), health status (people suffering from heart or blood pressure conditions, diabetes, depression, low mobility, and/or other chronic diseases) and social isolation.

1.2 Factors influencing indoor environmental quality in dwellings

People in the UK tend to spend 95% of their time indoors (Schweizer et al, 2007), a percentage that is likely to be even higher among elderly and low mobility individuals. This suggests that enhancing our understanding of the indoor climate in dwellings occupied by vulnerable people is vital in order to estimate *exposure* to heat and pollutants.

A series of recent modelling and monitoring studies have quantified the relative impact of building fabric characteristics on indoor overheating risk, the majority of which is reviewed in detail elsewhere (DCLG 2011). One of the recommendations of the DCLG review is that councils should ensure that vulnerable individuals are not housed in the most at-risk properties for overheating.

A consistent finding among various modelling studies is that purpose-built flats that are located in core urban areas and lack sufficient solar protection and/or ventilation are more prone to overheating (Orme and Palmer 2003, CIBSE 2005, Hacker et al, 2005, Salagnac 2007, Vandertorren 2007, Oikonomou et al, 2012, Mavrogianni et al, 2012). In particular, the relative risk of overheating in top floor 1960s flats is 6 times that of ground floor flats in the same block (depending on orientation) and around 9 times that of Victorian terraces (DCLG 2011).

A number of monitoring studies have also sought to address the relative overheating risk inside dwellings. For example, temperatures were recorded in 62 dwellings in Leicester during the 2006 heatwave; it was found that purpose-built flats and post-1990 houses were at highest risk of overheating (Firth and Wright 2008), corroborating the results of the modelling studies.

Taking into account that a large proportion of high-rise housing developments in the UK belong to the social housing sector, it is suggested that adaptation studies should give particular emphasis to this dwelling type. As highlighted by the recent London Climate Change Partnership's (LCCP) report *Your Social Housing In A Changing Climate* (LCCP 2013), most of the social housing in London was not constructed with climate change in mind and, thus, its widespread climate proofing is an emergent need. In addition, social housing residents, in particular, may not have the means to adapt their homes to a changing climate by themselves, and negative impacts of climate change on social housing are likely to have repercussions to entire communities.

It has been suggested that occupant behaviour can have a measurable impact on indoor overheating (Coley et al, 2012, Porritt et al, 2012), with increased ventilation and window shading having a significant potential to mitigate excess temperatures. Unfortunately, as indicated in a recent review by Fabi et al, (2013), actual data on the way people operate their homes during the summer period is scarce, as most relevant research on window opening patterns is focused on office buildings. There is, nevertheless, some evidence of a correlation between window opening frequency/duration and external temperature, as well as indoor activities in dwellings (IEA Annex 8, Dubrul et al, 1988).

The majority of UK dwellings are naturally ventilated, and while increasing ventilation through window opening may act to reduce indoor temperatures, it also causes an increase in the infiltration of outdoor pollution into the internal air. In urban centres, levels of outdoor pollutants such as PM_{2.5}, NO₂, and SO₂ can be high due to high volumes of traffic, dense road networks, and industry. Pollutants may also be generated from indoor activities, for example cooking, smoking, and cleaning (Shrubsole 2012). Air quality has an important impact on population health; PM_{2.5}, for example, has been associated with health problems such as respiratory and cardiovascular disease (Brunekreef 2002), and is estimated to cause a 7.17% fraction of mortality in London (PHE 2013). Ventilation is a key determinant of indoor pollution exposure, and the temperature-dependent window-opening behaviour of dwelling occupants may influence the degree of exposure, particularly to pollution from outdoor sources.

1.3 Study aims

Due to the increased overheating risk in certain dwelling types, the urban heat island, and the vulnerability of the occupant population in social housing, there is an urgent need to study the summertime thermal performance of high-rise council flats in central London. This paper presents preliminary results obtained from a pilot monitoring and modelling study designed as a follow-up to the DEFRA-funded Climate Resilience Islington South Project (CRISP). The main aim of CRISP was to interview vulnerable South Islington residents in order to explore their attitudes towards, and preparedness for, climate change-induced risks, such as heatwaves and flooding; the results of the main study have been presented in detail elsewhere (Kolm-Murray et al, 2013).

The geographical focus of CRISP was the South Islington area, comprising of Bunhill, Clerkenwell and Pentonville, in central London. As mentioned previously, the borough of Islington has been identified as a ‘triple jeopardy hotspot’ (MoL 2012) on the basis of its heatwave vulnerability for the following reasons:

- Islington is located in an area characterised by high urban heat island intensities.
- It is the most densely populated borough in the UK with 206,100 people inhabiting just 5.7 square miles.
- It has the second lowest proportion of green surface areas in the UK (after the City of London).
- It is the 14th most deprived borough in England and is characterised by high inequality levels.
- It has the lowest male life expectancy in London, and its population is characterised by a high prevalence in cardiovascular and respiratory conditions, which are significant heat sensitivity proxies.
- It is experiencing unprecedented levels of gentrification which could further compound problems of social isolation among the elderly, long-term social housing tenants.
- A large proportion of residents live in council-owned flats in tower blocks or other types of high-rise social housing.

This paper focuses on the results obtained from a case study flat located on a mid-floor of a high-rise purpose-built council tower block in the borough. Its aims are two-fold:

- to assess the current summertime thermal performance of the case study flat, using monitoring; and
- to explore the complex interactions of summertime ventilation behaviour, indoor temperature and air pollutant concentration under different occupancy, operation, retrofit and climate scenarios, using a coupled dynamic thermal and air contaminant transport model.

2 Methods

2.1 Case study building

As mentioned earlier, dwellings in high-rise 1960s social housing developments are considered to be at risk of overheating, and have often been subjects of modelling studies in the past that examined the risks associated with climate change and potential adaptation measures.

The case study block of flats is representative of high-rise developments constructed under the Social Housing Schemes in the 1960s and 70s, the structural characteristics of which are widely documented (Chown 1970, Glendinning and Muthesius, 1994, Capon and Hacker, 2009). The Borough of Islington housing production peaked before the 1970s with the Housing Development Area Programme, when a number of residential tower blocks similar to the case study building were constructed to last until the mid-21st century (Glendinning and Muthesius 1994).

The tower block under examination was built in 1963. It is a 17-storeys high block of 97 units, 21 of which are occupied by people aged over 65 (around 2.5 times the proportion of those 65+ at borough level), therefore a vulnerable group in terms of overheating risk (Kolm-Murray 2013). The tower block has a symmetrical U-shaped

layout, with the long side facing broadly north-south. The building is largely unshaded, although a recent development directly to the south offers some shading to the lower floors. The main entrance hall is accessible via the south and the north side of the building and leads to two central staircases and elevator towers. On the ground floor, other uses are accommodated along with the caretaker's flat, linked with office and workshop spaces. The community centre and a nursery which includes an extension to the west have separate entrances. A typical floor plan is shown in Figure 1. The drawings were reproduced from drawings available by Homes for Islington and were based on interpretation of photos and onsite visits including detailed measurements inside the case study mid-floor flat facing southwest (CW). Most floors contains 6 two-bedroom flats with an area of 55 to 60 m² each, accessible via an external corridor on the north side. Four out of six of the properties in each floor are single aspect to the south. Above the roof level, water tanks, two lift motor rooms and a ventilation chamber are located. The roof slab is covered by concrete tiles. The walls are predominantly concrete system-build (frame-infilling and frame-cladding structures), but with some small areas of insulated cavity wall. There are a few sections of uninsulated cavity wall at ground level. Double-glazed windows with trickle vents were installed in 2004/05.



Figure 1. Standard floorplan of the case study building

2.2 Monitoring of indoor thermal conditions

Onset HOBO U12-012 data loggers (Onset Computer Corporation 2013), were used for the monitoring of indoor thermal conditions in the case study flat (mid-floor, flat CW in Figure 1). The loggers recorded dry bulb air temperature (accuracy ± 0.35 °C from 0 to 50° C) at 15-minute intervals for 2 months during the summer (early July to early September 2013). The sensors were placed in convenient locations at approximately eye level and away from sources of direct light and heat, such as radiators, light bulbs, televisions or other large electronic appliances. One sensor was installed in the main living area and one in the main sleeping space. During the survey visit of the property, information about construction materials (including wall types, insulation levels and double glazing) and dimensions were collected. Indoor air quality was not monitored due to its increased cost but it is envisaged that future work will monitor indoor air pollutants alongside hygrothermal conditions.

2.3 Modelling of indoor thermal conditions

A simplified geometric model of the case study building was constructed using the widely tested and validated building performance modelling software EnergyPlus, version 8.0.0.007 (US DoE 2014). To assess the heat and pollutant exposure risk levels of vulnerable occupants, it was assumed that the flat was occupied by a couple of elderly individuals who remained constantly indoors. The occupancy patterns of the residents, and the resulting appliances use and internal heat gains were specified in line with previous studies (Oikonomou et al, 2013, Mavrogianni et al, 2012, Mavrogianni et al, 2013, Taylor et al, 2014, Mavrogianni et al, 2014). Simulations were then run for the following combinations:

- two levels of building fabric efficiency levels (as built and retrofitted); and
- two types of window and shading operation (daytime ‘rapid’ ventilation vs. night time ‘purge’ cooling combined with daytime shading).

The existing building fabric was modelled according to information from the site visit and architectural drawings. U-values for the walls, ground floor, roof, and windows were inferred based on the construction age of the case study building using the RdSAP methodology (BRE 2009). The building structure is a typical reinforced concrete frame grid; external walls are mainly precast concrete parts with no insulation (U-value = 2.00 W/m²K). The floors consist of 20 cm thick hollow pot concrete slabs. Windows were modelled as being post-2002 double-glazed with a uPVC frame (U-value = 2.00 W/m²K). Air infiltration was modelled through the permeability of the building envelope, taken to be 11.5 m³/m²h @ 50 Pa for unretrofitted walls. The retrofit scenario consists of the addition of wall insulation applied internally (retrofitted wall U-value = 0.60 W/m²K), the replacement of windows with triple glazing (U-value = 1.80 W/m²K) and the improvement of building fabric permeability to 5 m³/m²h @ 50 Pa according to values provided for ‘best-practice’ retrofitted dwellings. Due to the limited overshadowing levels of mid-floor flats by surrounding buildings, the case study was simulated as a stand-alone tower and no adjacent volumes were included in the model.

A simple window opening pattern depending on internal temperatures was specified in the model. Windows were assumed to open when temperature exceeds the CIBSE Guide A upper thermal comfort temperature, which is 23 °C for bedrooms and 25 °C for living rooms and other spaces, and to have 100% aperture when internal operative temperature reaches the overheating limit, which is 26 °C for bedrooms and 28 °C for living rooms and other spaces (CIBSE 2006). In addition, windows were assumed to close when the external temperature exceeds the internal operative temperature. The internal doors of the living room and kitchen were considered to be always open, while bedroom doors were considered to be closed during the night. The door of the bathroom was considered to be open when unoccupied. Two natural ventilation and cooling strategies were tested: The daytime ‘rapid’ ventilation scenario assumed that all windows open if the internal temperature goes above CIBSE overheating thresholds (as explained above) and close if the external rises above the internal, during the entire day if the room is occupied. The night cooling scenario assumed that all windows would open if the internal temperature goes above CIBSE overheating thresholds (as explained above) and close if the external rises above the internal only during the night time between 22:00 and 6:00; this strategy was combined with internal blinds which remained closed during the day between 7:00 and 19:00. The second scenario represents three of the recommendations of the Heatwave Plan for England (NHS England and PHE 2013), as summarised in the Key Public Health

Messages, i.e. to keep indoor environments cool by keeping windows that are exposed to the sun closed during the day; opening windows at night when the temperature has dropped; and closing curtains that receive morning or afternoon sun.

A number of recent EPSRC-funded research projects have generated hourly weather files which are based on the UK Climate Projections (UKCP09, UKCIP 2009) such as the PROMETHEUS project (Eames et al, 2011). These weather files are appropriate for building simulations, and are available for several future time slices, and a number of UK locations. A PROMETHEUS Design Summer Year (DSY) weather file for Islington, London, was used in the present study to represent a hot, but not extreme, summer period. The DSY has some recognised limitations that contradict its definition as a near extreme summer year, and has been found not to be always a reliable metric for overheating for certain UK locations (CIBSE 2009). The reason for this is that a relatively cooler summer can have strong heatwaves, causing more overheating problems than a generally warmer summer (i.e. that of a DSY) with less intense peaks in temperatures. Nonetheless, DSYs are the standardised weather files used for overheating analysis. Ideally, a full climate change impact assessment study would compare different time slices, e.g. 2030s vs. 2050s and 2080s. However, the PROMETHEUS weather files are created using the UKCP09 weather generator and, therefore, each file is characterised by different weather patterns. As pointed out by the creators of the files, one of the limitations of the probabilistic climate information and the weather patterns variation is that this could result in unexpected outcomes, such as reduced hours of overheating in 2080 compared to 2050, hence their direct comparison is not advised. Taking into consideration the case study building's projected lifetime, one DSY weather file, representing the projected climate for Islington in the 2050s under the a1b Medium emissions scenario (50th percentile) was used to model the potential overheating risk in the case study building due to future climate change.

2.4 Modelling of indoor air pollutant concentrations

In addition to thermal modelling, EnergyPlus was used to simulate the infiltration of PM_{2.5} from the outdoor environment into the indoors. The airflow network algorithm and the recently introduced generic contaminant model of EnergyPlus v. 8.0.0.007 (US DoE 2014) allows the simultaneous simulation of the thermal, airflow and air contaminant transport behaviour of a building. Only PM_{2.5} infiltration from the outdoor environment was considered. The constant outdoor PM_{2.5} concentration was set to 13 µg/m³, the average PM_{2.5} concentration for London according to existing literature (Shrubsole et al, 2012), with a deposition rate of 0.00010833 m/s. No internal sources were included in the model as the objective of the paper is to examine infiltration of outdoor pollutants into the indoor environment. The ratios of indoor/outdoor (I/O) concentrations for each room were then calculated for the modelled summer period.

2.5 Overheating assessment criteria

There has been significant debate in recent years regarding defining indoor overheating criteria, especially for free-running dwellings (CIBSE 2006, BSI 2007, Roberts 2008, Nicol et al, 2009, Peacock et al, 2010, Gupta and Gregg 2012, Porritt et al, 2012, Lomas and Kane 2012, CIBSE TM52 2013, Lee and Steemers 2013). Whilst the static, single temperature exceedance criteria are simpler to use, they have been widely criticised for not factoring in acclimatisation effects and other factors of adaptive capacity (Nicol 2009). Following a review by the CIBSE Overheating Taskforce, new overheating criteria were produced which adopt the adaptive approach

to thermal comfort (CIBSE TM52, CIBSE 2013), which are based on BS EN 15251 (BSI 2007). It is pointed out that although the guidance is primarily intended for application to non-domestic buildings, the approach is, to a large extent, relevant to overheating assessment in domestic buildings. For instance, a recent study by Lomas and Kane (2012) compared the static CIBSE criteria (CIBSE 2006) to the newly introduced adaptive criteria (CIBSE 2013) and suggested that although the static criteria are simpler to use, the adaptive approach is more appropriate for free-running buildings where occupants have high adaptive capacity, such as opening windows, using blinds and curtains, consuming cold beverages, having cold showers and adjusting clothing and metabolic activity levels. However, there are some issues regarding the applicability of adaptive criteria in residential spaces occupied by vulnerable individuals during heatwave periods that require further investigation. First, the adaptive thresholds were initially developed for office buildings; further research is needed to see how these could be adapted for residential environments. A wider range of adaptive opportunities are usually available to people at home compared to office buildings, and, thus, the use of the current BS EN 15251 temperature ranges may overestimate heat-related discomfort; they could, however, still be used to indicate upper thresholds of comfort. Second, Porritt et al, (2012) notes that the BS EN 15251 adaptive thresholds are not adequately tested for running mean outdoor temperatures above 25 °C. Furthermore, taking into consideration that vulnerable individuals, such as bed-ridden and elderly occupants are less able to modify their immediate environment or acclimatise to the external weather, a more static criterion may still be suitable for the assessment of overheating in such properties.

Taking the above into account, indoor overheating was assessed using both sets of criteria for the monitored case study and the modelled dwelling variants:

- the static single temperature exceedance approach (CIBSE Guide A, CIBSE 2007);
- the adaptive external climate dependent approach (CIBSE TM52, CIBSE 2013).

According to the static thresholds of CIBSE Guide A (CIBSE 2006), overheating in naturally ventilated residential spaces is deemed to occur when indoor temperature exceeds the specified thresholds for at least 1% of the occupied hours during the summer period (Table 1), a series of metrics clearly influenced by occupancy patterns (Lee and Steemers 2013).

Table 1. CIBSE Guide A General summer indoor comfort temperatures, benchmark summer peak temperatures and overheating criteria for free-running dwellings

Room type	Operative temperature for indoor comfort in summer	Benchmark summer peak temperature	Overheating criterion
Living rooms	25 °C	28 °C	1% annual occupied hours over 28 °C
Bedrooms	23 °C (sleep may be impaired above 24 °C)	26 °C	1% annual occupied hours over 26 °C

The adaptive equation for comfort used in BS EN 15251 relates the indoor comfort temperature to the outdoor air temperature. A full multi-criteria adaptive thermal comfort analysis exceeds the scope of the present paper. Indicatively, only Criterion I of the adaptive approach was applied to estimate the frequency of overheating occurrences in the monitored dwelling and modelled variants, according to which the difference between the internal operative temperature and T_{max} should be not greater than or equal to 1 °C for more than 3% of occupied hours during the summer period, where T_{max} is given by equation (1) of Category III (existing buildings where there are moderate expectations as regards to the thermal environment):

$$T_{max} = 0.33T_{rm} + 22.8 \text{ °C} \quad (1)$$

where T_{rm} : the exponentially weighted running mean of the daily-mean outdoor air temperature

The analysis of indoor air quality did not apply similar criteria for indoor pollution levels as there is no ‘safe’ threshold for $PM_{2.5}$.

3 Results and discussion

3.1 Current summer thermal performance

The period of monitoring occurred during late summer, and included a hot spell from July 12th to July 23rd during which outdoor temperatures achieved a maximum of 33.2 °C at London Heathrow¹, and averaged 23.4 °C during the daytime and 22.8 °C at night. The overheating assessment results are summarised in Table 2.

Table 1 Hours above overheating thresholds for bedrooms and living rooms during the monitoring period in the case study flat. Brackets () indicate the percentage of monitored hours that overheating occurred, highlighted cells indicate overheating occurring for above 1% of the monitored hours.

Criterion	Living room			Bedroom			
	> 25 °C	> 28 °C	> T_{max} + 1 °C	> 23 °C	> 24 °C	> 26 °C	> T_{max} + 1 °C
Hours	328	29	0	286	187	50	0
(% occupied)	(43.9%)	(3.9%)	(0.0%)	(64.7%)	(42.3%)	(11.3%)	(0.0%)

The internal temperatures measured in the living rooms of the case study flat are demonstrated in Figure 2, and the bedroom temperatures in Figure 3, alongside the external temperature during the monitoring period and the static and adaptive thresholds for summer overheating and excess cold. Indoor temperatures in living rooms were found to exceed the 28 °C overheating threshold only during the hot spell period, while the 25 °C upper thermal comfort threshold was exceeded regularly during the monitoring period. Bedrooms exceeded the 23 °C and 24 °C upper thermal comfort and sleep disruption thresholds regularly, and exceeded the 26 °C overheating threshold during the hot spell event, and later in the observation period when heating systems are likely to have been switched on. Interestingly, the internal temperature

¹ Although it would have been preferable to plot internal temperatures against local external temperature in Islington, the measurements at the London Heathrow station were deemed more reliable. It needs to be noted, however, that they do not fully capture local heat island effects.

lies well below the TM 52 Criterion I overheating threshold for the entire monitoring period. The results presented above indicate that the case study flat is prone to overheating during a period of hot weather under the current climate, if the static threshold approach is adopted, which does not factor in acclimatisation and other adaptation actions the residents may take. Considering the fact that the adaptive capacity of most vulnerable individuals residing in social housing units is likely to be fairly limited, this is an indication that attention needs to be paid to such properties. However, when the adaptive approach is used, the risk of overheating appears to be significantly lower under the current climate.

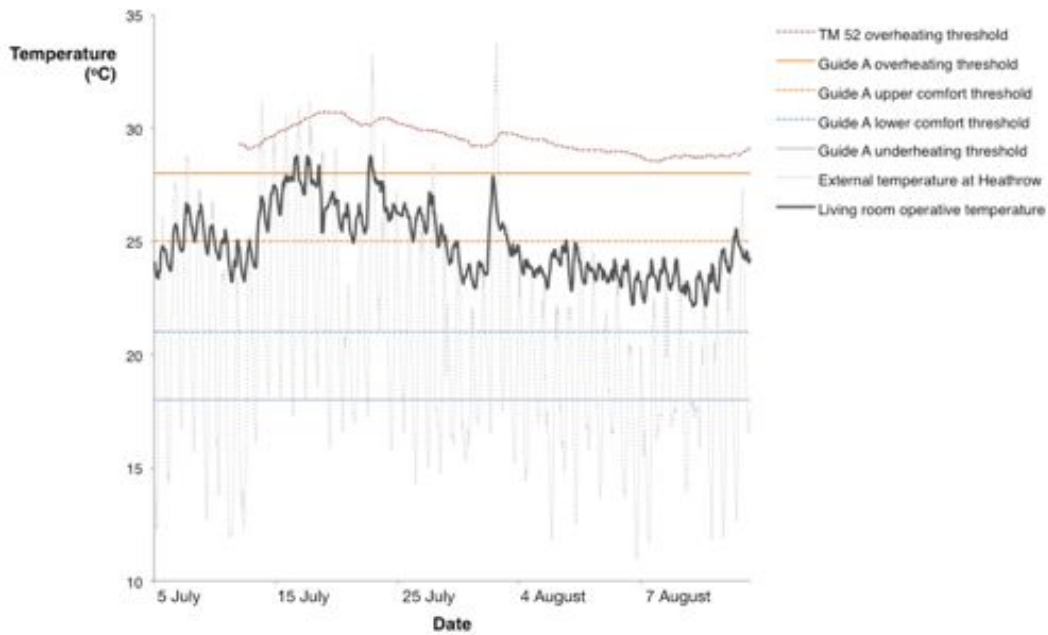

Figure 2. Living room temperature during the monitoring period

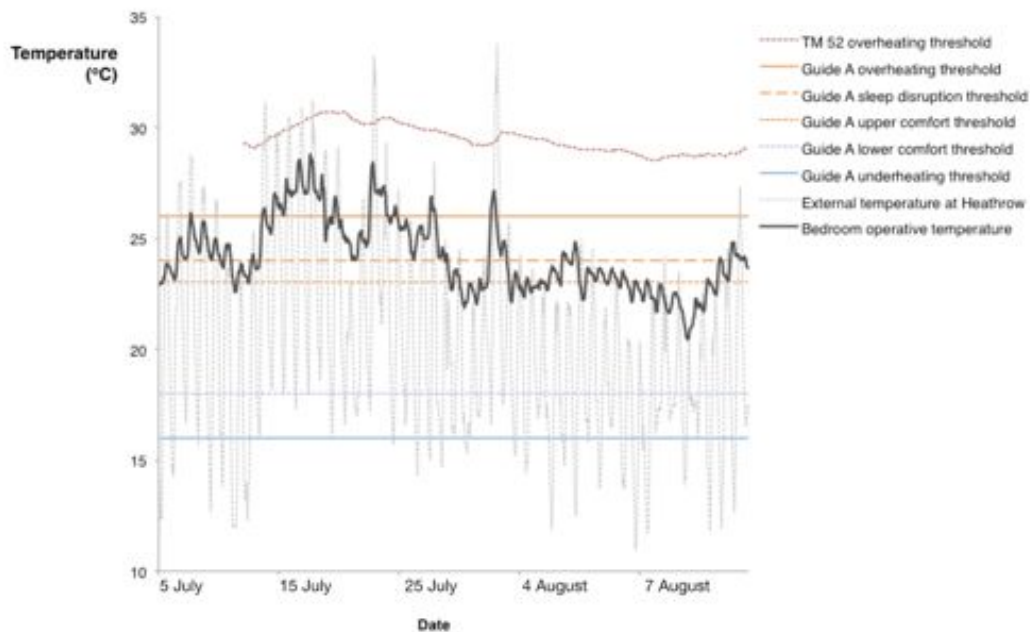

Figure 3. Bedroom temperature during the monitoring period

3.2 Future summer thermal performance and indoor air quality

The EnergyPlus simulation results are explored to further assess the overheating risk in the case study in the future. As illustrated in Figure 4, the living room of the flat is projected to face a significant risk of overheating in the 2050s under the Medium (a1b) emissions scenario. As is evident from the graph, an unintended consequence of the thermal upgrade of the building envelope with the specific measures described earlier appears to be the increase of summer indoor temperatures, with more than 70% of occupied hours above 25 °C under all variations, approaching 100% of the time for the retrofitted scenario with night only cooling and shading. Hours above 28 °C occur for between 24% to 60% of occupied time, which is well above the 1% CIBSE Guide A threshold, whereas when the adaptive thermal comfort criterion is applied, living room temperatures are found to be equal or higher than the specified overheating limit for 3% of the time or higher. An important finding to emerge from this analysis is that, for this dwelling geometry and the specific set of assumptions made, the daytime ‘rapid’ ventilation strategy appears to be more effective than the night cooling scenario combined with daytime shading (around 17% less hours above 28 °C for the retrofitted variant). This suggests that the solar protection offered by the internal curtains and the night cooling effect do not adequately cool down the south-oriented, constantly occupied during the daytime, living room. It is, thus, recommended that properties of this type, which are heavily occupied by vulnerable individuals during the daytime, are either ventilated throughout the day or are protected by more efficient solar protection measures, such as external louvres or other shading devices.

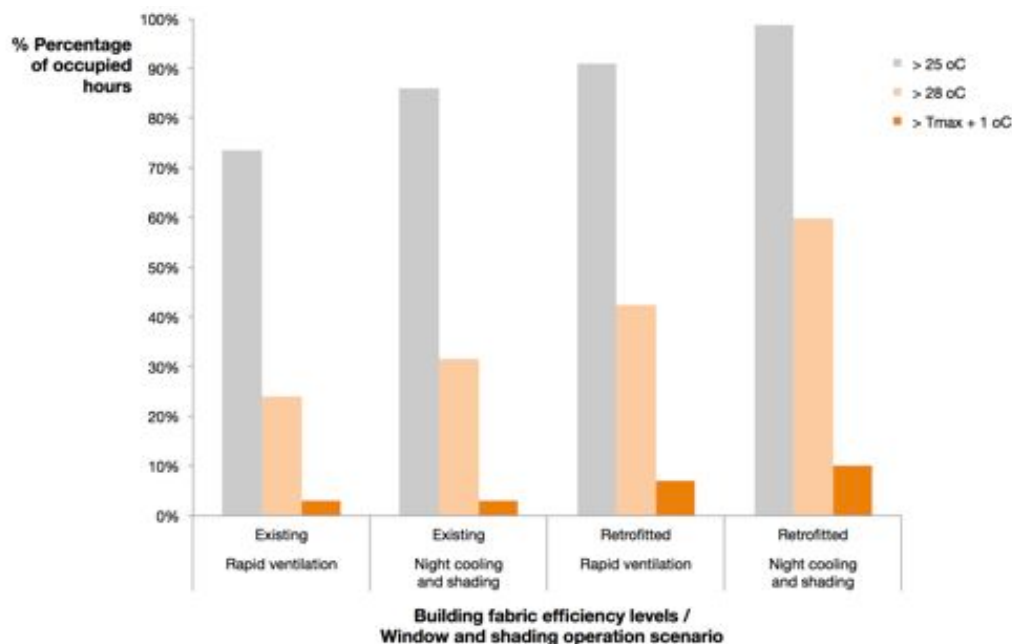

Figure 4. Living room exceedance of overheating thresholds during the summer period under the 2050s Medium emissions 50th percentile UKCP09 scenario

Similar levels of overheating are observed in the bedroom, however, night ‘purge’ cooling seems to be more successful in reducing temperatures (around 10% less hours above 26 °C for the retrofitted variant).

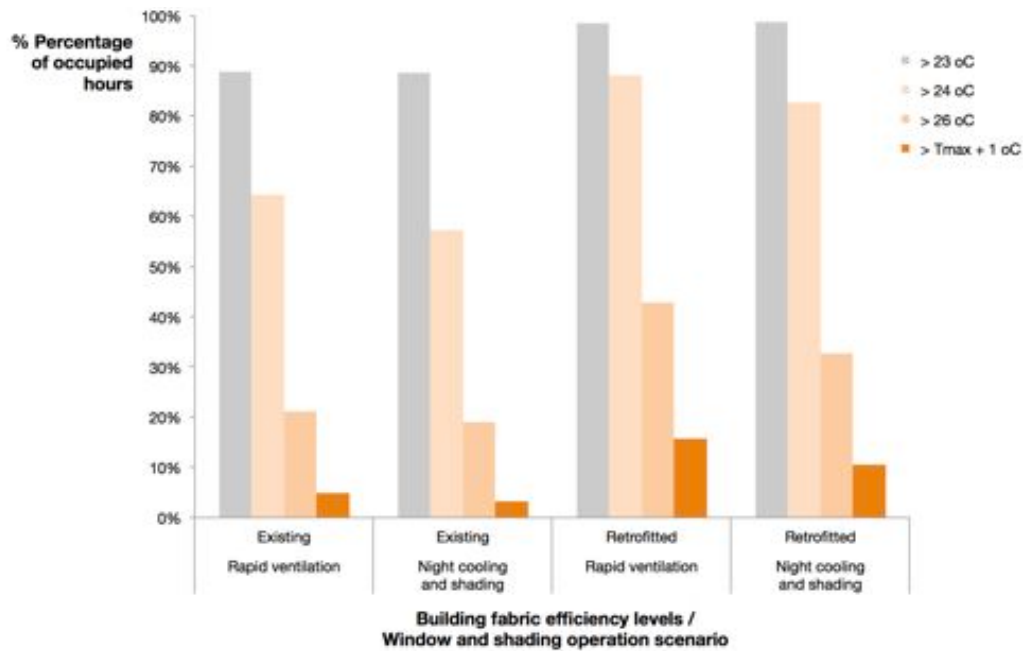

Figure 5. Bedroom exceedance of overheating thresholds during the summer period under the 2050s Medium emissions 50th percentile UKCP09 scenario

Whilst night ventilation may offer some relief from elevated night time temperatures in the bedroom, potential trade-offs between thermal comfort and indoor air quality need to be investigated. Figure 6 attempts to explore such interaction effects during the 3 hottest consecutive days of the selected weather file (14th-17th August). As can be observed from the graph, in the evening, bedroom internal temperatures rise above the window opening threshold of 23 °C, which causes windows to remain open for most of the night and PM_{2.5} I/O ratios to approach 1.0 due to the ingress of outdoor air, an effect that is common for both ventilation strategies. During the day, when the bedroom is unoccupied I/O ratios fall markedly but still lie above 0.5 for most of the time. An implication of this finding is that the applicability of night ventilation strategies as, for example, suggested by the NHS Heatwave Plan, may be hindered in dwellings similar to the case study flat located in core urban areas due to outdoor pollution concerns. A significant limitation of the present study is, however, the omission of indoor PM_{2.5} sources or other internally generated pollutants.

The present study belongs to a series of pilot evaluations of coupled thermal comfort and indoor environmental quality models (Mavrogianni et al, 2013). Ongoing work as part of the EPSRC project 'Air Pollution and WEather-related Health Impacts: Methodological Study based On spatio-temporally disaggregated Multi-pollutant models for present day and futurE' (AWESOME 2014) aims to further develop such combined temperature and multi-pollutant models for a wide range of representative building typologies of the UK housing stock.

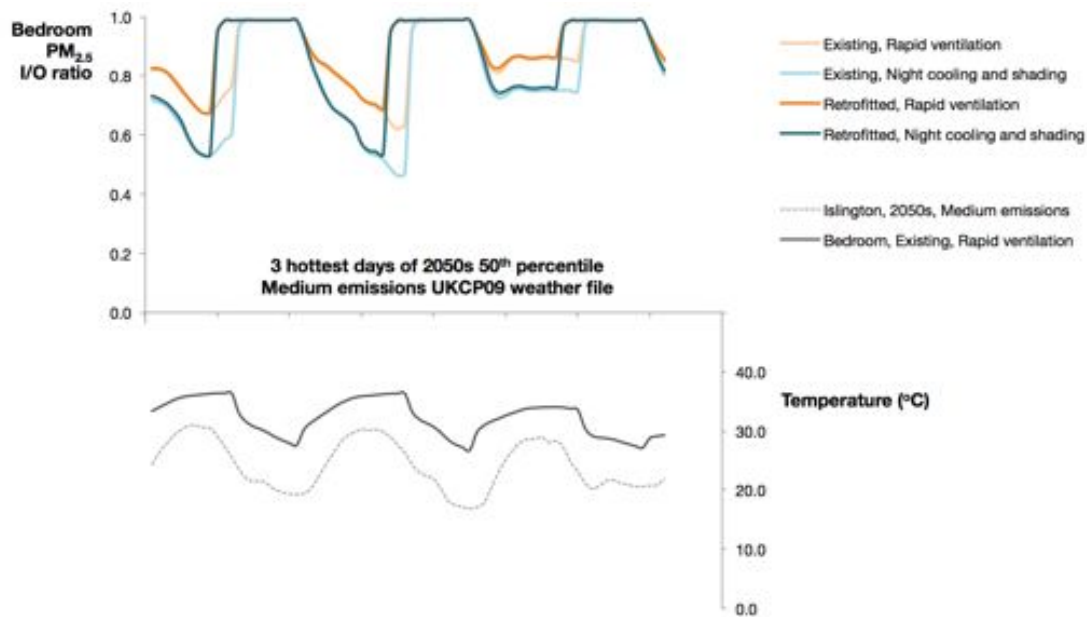

Figure 5. Bedroom temperature and $PM_{2.5}$ I/O ratios during the 3 hottest consecutive days of the 2050s Medium emissions 50th percentile UKCP09 scenario

4 Conclusions

This study set out to determine the current levels of overheating risk in a mid-floor south-facing flat of a social housing tower block in central London, occupied by vulnerable individuals, and evaluate the levels of future risk due to background regional warming and potential interaction effects with indoor air quality. The analysis of the monitored data suggested that the case study flat already experiences hours with temperatures above the recommended thresholds, even during a relatively mild summer like the one of 2013. It was shown, however, that estimates of the magnitude of current summer thermal discomfort risk largely depend on the criterion used; static or adaptive. In the future, such risks are likely to be exacerbated by a rise in ambient temperatures and certain retrofit measures (increased airtightness, internal wall insulation). Natural ventilation alone may not suffice to keep indoor thermal conditions within acceptable limits and its cooling potential may be further limited due to outdoor air pollution concerns. This preliminary study enhances our understanding of the complex interrelationships between the indoor thermal environment and airborne contaminant transport in heat vulnerable urban homes. It is recommended that a holistic modelling approach is adopted prior to the design of retrofit interventions in heat-vulnerable properties.

Acknowledgements

The assistance of Islington Council with participant recruitment and building information provision is thankfully acknowledged.

References

AWESOME, 2014. *Air Pollution and WEather-related Health Impacts: Methodological Study based On spatio-temporally disaggregated Multi-pollutant models for present day and futurE*. Available online at: <<http://awesome.lshtm.ac.uk/>> [Access date: 1 February 2014]

Beniston, M., Stephenson, D. B., Christensen, O. B., Ferro, C. A. T., Frei, C., Goyette, S., Halsnaes, K., Holt, T., Jylhä, K., Koffi, B., Palutikof, J., Schöll, R., Semmler, T., Woth, K. 2007. Future extreme events in European climate: an exploration of regional climate model projections. *Climatic Change*, 81(1), Supplement, pp 71-95.

Brunekreef, B., Holgate, S. T., 2002. Air pollution and health. *The Lancet*, 360(9341), pp 1233-1242.

BRE, 2009. *The Government's Standard Assessment Procedure for Energy Rating of Dwellings (SAP), 2009 edition, version 9.90*. Building Research Establishment (BRE), Department for Energy and Climate Change (DECC). Watford, UK: Crown. Available online at: < http://www.bre.co.uk/filelibrary/SAP/2009/SAP-2009_9-90.pdf> [Access date: 1 February 2014]

BSI, 2007. *BS EN 15251: 2007, Indoor environmental input parameters for design and assessment of energy performance of buildings addressing indoor air quality, thermal environment, lighting and acoustics*. British Standards Institution (BSI). London, UK: BSI.

Capon, R.M Hacker, J. N., 2009. Modelling climate change adaptation measures to reduce overheating risk in existing dwellings. In: *11th International Building Performance Simulation Association (IBPSA) Building Simulation 2009 Conference*. University of Strathclyde, 27th-30th July 2009, Glasgow, Scotland: IBPSA.

Chown, I., 1970. Houses and flats. In: Littlefield, D. (Ed.), *Metric Handbook: Planning and Design Data*. Oxford, UK: Elsevier.

CIBSE, 2005. *Climate change and the indoor environment: Impacts and adaptation. TM 46*. The Chartered Institution of Building Services Engineers (CIBSE). London, UK: CIBSE

CIBSE, 2007. *Guide A, Environmental design. Guide A*. The Chartered Institution of Building Services Engineers (CIBSE). London, UK: CIBSE.

CIBSE, 2009. *TM 48, Use of climate change scenarios for building simulation: The CIBSE future weather years*. The Chartered Institution of Building Services Engineers (CIBSE). London, UK: CIBSE.

CIBSE, 2013. *TM52, The limits of thermal comfort: avoiding overheating in European buildings*. The Chartered Institution of Building Services Engineers (CIBSE). London, UK: CIBSE.

Coley, D., Kershaw, T., 2009. Changes in internal temperatures within the built environment as a response to a changing climate. *Building and Environment*, 45(1): pp 89-93.

Collins, L., Natarajan, S., Levermore, G., 2010. Climate change and future energy consumption in UK housing stock. *Building Services Engineering Research and Technology*, 31(1): pp 75-90.

DCLG, 2011. *Investigation into overheating in homes, Literature review*. Department for Communities and Local Government (DCLG). London, UK: DCLG.

DEFRA, 2013. *The national adaptation programme: Making the country resilient to a changing climate*. Department of Environment, Food and Rural Affairs (DEFRA). London, UK: DEFRA.

Dubrul, C. 1988. *Inhabitant behaviour with respect to ventilation - A summary report of IEA Annex VIII*. International Energy Agency (IEA). Berkshire, UK: IEA.

Eames, M., Kershaw, T., Coley, D., 2010. On the creation of future probabilistic design weather years from UKCP09. *Building Services Engineering Research and Technology*, 32(2) pp 127-142.

Fabi, V., Andersen, R. V., Corgnati, S., Olesen, B. W. Occupants' window opening behaviour: A literature review of factors influencing occupant behaviour and models. *Building and Environment*, 2012(58), pp188–98.

Firth, S. K.m Wright, A. J., 2008. Investigating the thermal characteristics of English dwellings: Summer temperatures. *Network for Comfort and Energy Use in Buildings (NCEUB) Conference, Air Conditioning and the Low Carbon Cooling Challenge*. Cumberland Lodge, Windsor, 27th-29th July 2008, Windsor, UK: NCEUB.

Glendinning, M., Muthesius, S., 1994. *Tower Block: Modern Public Housing in England, Scotland, Wales, and Northern Ireland*. London, UK: Paul Mellon Centre for Studies in British Art.

Gupta, R., Gregg, M., 2012. Using UK climate change projections to adapt existing English homes for a warming climate. *Building and Environment*, 55, PP 20-42.

Hacker, J. N., Belcher, S. E., Connell, R. K., 2005. *Beating the heat, Keeping UK buildings cool in a warming climate, UKCIP Briefing Report*. United Kingdom Climate Impacts Programme (UKCIP). Oxford, UK: UKCIP.

Hajat, S., Kovats, R. S., Lachowycz, K., 2007. Heat-related and cold-related deaths in England and Wales: who is at risk? *Occupational and Environmental Medicine*, 64(2): 93 - 100.

IPCC, 2007. Working Group II Report, Impacts, Adaptation and Vulnerability. In: Parry, M. L., Canziani, O. F., Palutikof, J. P., van der Linden, P. J., Hanson, C. E. (Eds.). *IPCC Fourth Assessment Report: Climate Change 2007*. Cambridge, UK and New York, USA: Cambridge University Press. Available online at: <http://www.ipcc.ch/publications_and_data/ar4/wg2/en/contents.html> [Access date: 1 February 2014]

Jenkins, G. J., Murphy, J. M., Sexton, D. M. H., Lowe, J. A., Jones, P., Kilsby, C. G., 2009. *UK Climate Projections: Briefing report*. United Kingdom Climate Impacts Programme (UKCIP), Met Office Hadley Centre. Exeter, UK: UKCIP, Met Office Hadley Centre.

Johnson, H., Kovats, R. S., McGregor, G., Steadman, J., Gibbs, M., Walton, H., The impact of the 2003 heat wave on daily mortality in England and Wales and the use of rapid weekly mortality estimates. *Eurosurveillance*, 10(7), Article 8.

Keatinge, W. R., Donaldson, G. C., Cordioli, E., Martinelli, M., Kunst, A. E., Mackenbach, J. P., Nayha, S., Vuori, I., 2000. Heat related mortality in warm and cold regions of Europe: observational study. *British Medical Journal*, 321: pp 670 - 673.

Kolm-Murray, J., Smith, A., Clarke, C., 2013. *Individual and community resilience to extreme weather events amongst older people in south Islington: attitudes, barriers and adaptive capacity*. London, UK: Islington Council.

Kovats, R. S., Kristie, L. E., 2006 Heatwaves and public health in Europe. *European Journal of Public Health*. 2006; 16: 592–599.

Kovats, R. S., Hajat, S., 2008. Heat Stress and Public Health: A Critical Review. *Annual Review of Public Health*, 29(1): 41-55.

LCCP, 2013. *Your Social Housing In A Changing Climate*. London Climate Change Partnership (LCCP). Available online at: <<http://climatelondon.org.uk/publications/yshcc/> [Access date: 1st February 2014]

Lee, W. V., Steemers, K., 2013. Beyond benchmark: accounting for exposure duration in overheating risk assessment method - A London mid-terraced dwelling case study. Liverpool John Moores University, 11th-12th April, *Chartered Institute of Building Services Engineers (CIBSE) Technical Symposium*, Liverpool, UK: CIBSE.

Lomas, K. J., Kane, T. (2012). Summertime temperatures in 282 UK homes : thermal comfort and overheating risk. *Network for Comfort and Energy Use in Buildings (NCEUB) 7th Conference, The changing context of comfort in an unpredictable world*. Cumberland Lodge, Windsor, 12th-15th April 2012, Windsor, UK: NCEUB.

Mavrogianni A., Wilkinson, P., Davies, M., Biddulph, P., Oikonomou, E., 2012. Building characteristics as determinants of propensity to high indoor summer temperatures in London dwellings. *Building and Environment*, 55: pp 117–130.

Mavrogianni A., Davies M, Taylor J., Raslan R., Oikonomou E., Biddulph P., Das P., Jones B., Shrubsole C. Assessing heat-related thermal discomfort and indoor pollutant exposure risk in purpose-built flats in an urban area. *CISBAT - International Conference on Clean Technology for Smart Cities and Buildings*, EPFL Lausanne, 4th-6th September 2013, Lausanne, Switzerland: CISBAT.

MoL, 2006. *London's Urban Heat Island, A Summary for Decision Makers*. Mayor of London (MoL), Greater London Authority (GLA). London, UK: MoL.

MoL, 2011. *Managing risks and increasing resilience, The Mayor's climate change adaptation strategy*. Mayor of London (MoL), Greater London Authority (GLA). London, UK: MoL.

NHS England, PHE, 2013. *Heatwave Plan for England*. London, National Health Service (NHS) England, Public Health England (PHE). London, UK: NHS.

Nicol, J. F., Hacker, J. Spires, B., Davies, H., 2009. Suggestion for new approach to overheating diagnostics. *Building Research and Information*, 37(4), pp 348-357.

Oikonomou, E., Davies, M., Mavrogianni, A., Biddulph, P., Wilkinson, P. and Kolokotroni, M., 2011. The relative importance of the urban heat island for overheating in London dwellings versus the thermal quality of the buildings. 57: pp 223-238.

Oke, T. R., 1982. The energetic basis of the urban heat island. *Quarterly Journal of the Royal Meteorological Society*, 108(455), pp 1–24.

Onset Corporation, 2014. *HOBO U10-012 data logger*. Available online at: <<http://www.onsetcomp.com/products/data-loggers/u12-012>> [Access date: 1st February 2014]

Orme, M., Palmer, J., 2003. *Control of overheating in future housing, Design guidance for low energy strategies*. Hertfordshire, UK: Faber Maunsell Ltd.

Peacock, A. D., Jenkins, D. P., Kane, D., 2010. Investigating the potential of overheating in UK dwellings as a consequence of extant climate change. *Energy Policy*, 38(7): pp 3277-3288.

- PHE. 2013. *Public Health Outcomes Framework Tool*. Public Health England (PHE). Available online at: <<http://www.phoutcomes.info/>> [Access date: 1st February 2014]
- Porritt, S. M., Shao, L., Cropper, P. C., Goodier, C. I., 2010. Occupancy patterns and their effect on interventions to reduce overheating in dwellings during heat waves. *Network for Comfort and Energy Use in Buildings (NCEUB) 7th Conference, Adapting to Change: New thinking on comfort*. Cumberland Lodge, Windsor, 9th-10th April 2010, Windsor, UK: NCEUB
- Roberts, S., 2008. Altering existing buildings in the UK. *Energy policy*, 36(12), pp 4482-4486.
- Roberts, S., 2008. Effects of climate change on the built environment. *Energy Policy*, 36(12), pp 4552-4557.
- Robine, J. M., Cheung, S. L., Le Roy, S., Van Oyen, H., Herrmann, F. R., 2007. *Report on excess mortality in Europe during summer 2003. 2003, Heat Wave Project, Grant Agreement 2005114*. EU Community Action Programme for Public Health. Available online at: <http://ec.europa.eu/health/ph_projects/2005/action1/docs/action1_2005_a2_15_en.pdf> [Access date: 1st February 2014]
- Schweizer, C., Edwards, R. D., Bayer-Oglesby, L., Gauderman, W. J., Ilacqua, V., Jantunen, M. J., Lai, H. K., Nieuwenhuijsen, M., Künzli, N., 2007. Indoor time-microenvironment-activity patterns in seven regions of Europe. *Journal of exposure science and environmental epidemiology*, 17(2): pp 170-81
- Salagnac, J.-L., 2007. Lessons from the 2003 heat wave: a French perspective. *Building Research and Information*, 35(4): pp 450-457.
- Shrubsole, C., Ridley, I., Biddulph, P., Milner, J., Vardoulakis, S., Ucci, M., Wilkinson, P., Chalabi, Z., Davies, M., 2012. Indoor PM_{2.5} exposure in London's domestic stock: Modelling current and future exposures following energy efficient refurbishment. *Atmospheric Environment*, 62, pp 336-343.
- The World Bank, 2008. *World Development Report 2009: Reshaping Economic Geography*. The International Bank for Reconstruction and Development. Washington, USA: The World Bank.
- UKCIP, 2009. *UK Climate Projection 2009 (UCKP09)*. Available online at: <<http://ukclimateprojections.metoffice.gov.uk/21678>> [Access date: 1st February 2014]
- US DoE, 2014. *EnergyPlus energy simulation software v. 8.0.0.07*. Available online at: <<http://apps1.eere.energy.gov/buildings/energyplus/>> [Access date: 1st February 2014]
- Taylor J., Davies M., Mavrogianni A., Chalabi Z., Biddulph P., Oikonomou E., Das P., Jones B., 2014. The relative importance of input weather data for indoor overheating risk assessment in London dwellings. *Building and Environment*, Under review.
- Vandentorren, S., Bretin, P., Zeghnoun, A., Mandereau-Bruno, L., Croisier, A., Cochet, C., Riberon, J., Siberan, I., Declercq, B., Ledrans, M., 2006. August 2003 Heat Wave in France: Risk Factors for Death of Elderly People Living at Home. *European Journal of Public Health*, 16(6): pp 583-591.

Proceedings of 8th Windsor Conference: *Counting the Cost of Comfort in a changing world* Cumberland Lodge, Windsor, UK, 10-13 April 2014. London: Network for Comfort and Energy Use in Buildings, <http://nceub.org.uk>

Indoor thermal conditions and thermal comfort in residential buildings during the winter in Lhasa, China

Haiyan Yan¹, Liu Yang^{2*}

1. College of Architecture & Art Design, Henan Polytechnic University, Jiaozuo, China, email yhy@hpu.edu.cn;
2. School of Architecture, Xi'an University of Architecture and Technology, Xi'an , China, email yangliu@xauat.edu.cn

Abstract

In order to research the indoor thermal conditions and residential thermal comfort in low-pressure plateau climate, a field study was conducted from December 2007 to February 2008 of 20 residential buildings in Lhasa. A total of 44 participants provided 356 sets of physical measurements together with subjective questionnaires that were used to collect the data. By linear regression analysis of responses based on the ASHRAE seven-point thermal sensation scale, the neutral air temperature of the total samples based on thermal sensation was 19.3°C. According to the Probit regression analysis, the lower limit of acceptable air temperature of 80% Lhasa occupants was 13.3°C. The results revealed that Lhasa occupants have adapted to the typical natural environment from physiologically, psychologically, and behaviorally.

Keywords: Plateau climate; Indoor thermal environment; Thermal comfort; Field study

1. Introduction

According to statistics, more than 520 million people worldwide now live on the mountains and plateaus in different altitudes. Figure 1 presents the distribution of Average Mean Sea Level (AMSL) of China, Qinghai-Tibet plateau is known as “the roof of the world” for the mean sea level altitude of over 4,000m. With a population of over 10 millions, it spreads over an area of a quarter of the whole Chinese territory. Therefore, China is one of the biggest plateau countries with the area of plateau. In recent years, with the implementation of China’s develop-the-west strategy and the operation of the whole Qinghai-Tibet railway, more and more people work, live, and travel on the plateau, which drives the economic development of Qinghai-Tibet plateau. Demands of improving the indoor thermal environment are strong as people’s living levels has been improved significantly.

The research on thermal comfort has been improved greatly in recent years, represented by Fanger’s climate chamber study [1] and Humphreys and de Dear’s field study [2-3]. Based on those researches, the international thermal comfort

standard ISO7730 [4] and ASHRAE55-2004 [5] had been formed. At present, most thermal comfort researches are conducted in the normal air pressure environment. It has been acknowledged that the diffusive transfer of water evaporation increases in the hypobaric conditions whereas dry heat loss by convection decreases [6-7]. Such changes in heat and mass transfer may cause the change of body heat loss, and then affect people's thermal comfort feeling [8].

Thermoregulatory responses in humans exposed to acute hypoxia have been studied extensively with most of researches on thermal perception [9-12] and reaction time [13, 14]. These studies focused on the effect of thermoregulatory responses of hypoxia. Hideo et al. [15] have studied the effect of hypobaric conditions by using decompression chamber to simulate different altitude. Their experiments showed that as altitudes rise, the skin temperatures of face and body are higher than those of extremities, and thermal sensations for the face and body become warmer. Thus, subjects found that it was difficult to express their thermal states. Haiying Wang et al. [16] clarified the effects of barometric on human thermal comfort, and have proved that as the air pressure reduces, the mean thermal sensation votes (MTSV) falls. Under the condition of the same environmental parameters, people tend to feel cooler in hypobaric environment. These studies were made in the decompression chamber to simulate the barometric conditions in 1atm, 0.85atm and 0.75atm, which are equivalent to the altitude of 0m, 1300m, and 2300m respectively. However, what are the real thermal conditions and thermal comfort of people who live in the plateau above 4000m?



Figure 1. The distribution of Average Mean Sea Level of China and location of Lhasa.

In recent years, many field studies on the thermal comfort performed in China mostly focused on the southeast coastal areas in a normal air pressure conditions [17-25]. Therefore, it is essential to carry out the field study of thermal comfort in the plateau climate. This research was conducted in Lhasa of Qinghai-Tibet plateau. The objectives of this study are to investigate the indoor thermal conditions of the occupants in residential houses in Lhasa in plateau climate, to analyze the subjective responses and

thermal comfort for Lhasa context; to compare this study with other field studies, and to find the adaptive opportunities that influence thermal comfort perception in plateau climate.

2. Geography and Climate characteristics of Lhasa

Lhasa, the capital of Tibet in China, is an ancient city with a history of more than 1300 years. It situates at 29°72' north latitude, and 91°03' east longitude. With an altitude of 3,650 meters height (11,975 feet), Lhasa is one of the highest cities in the world. The average air pressure (652mbar) of Lhasa is only about two-thirds of

normal air pressure (1,000mbar). Lhasa belongs to typical plateau continental climate with cold winter and cool summer, little rain. The annual average temperature is 7.8°C, which is much lower than the regions with the same latitude of the country. The mean temperature of the coldest month (January) is -1.6°C, and the mean temperature of the hottest month (June) is 15.9°C. The city experiences a large temperature difference from day to night, about 13K-15K, however, the annual temperature range of Lhasa is only 17.5°C. Lhasa enjoys the reputation of “sunshine city”, because it receives 7,318.0 MJ/m² solar radiations every year. There are about 3,000 hours in annual sunshine time.

Our research team conducted the tests to measure the solar radiation in Lhasa in the typical summer day of 2006 and the typical winter day of 2007, as shown in Figure 2. During the survey days, the sunshine duration in Lhasa in summer was 12-13hours, the average intensity of the total solar radiation of the sunshine time was 0.75kW/m², and the peak value of 1.2kW/m² appeared at about 14:00. The sunshine duration in winter was 10-11hours, the average intensity of the total solar radiation of the sunshine time was 0.45kW/m², and the peak value of 0.75kW/m² also appeared at about 14:00. The direct solar radiation of winter and summer accounts for about 90% and 85% of the total solar radiation intensity, respectively, which reflects the rich solar radiation resources in Lhasa area [26].

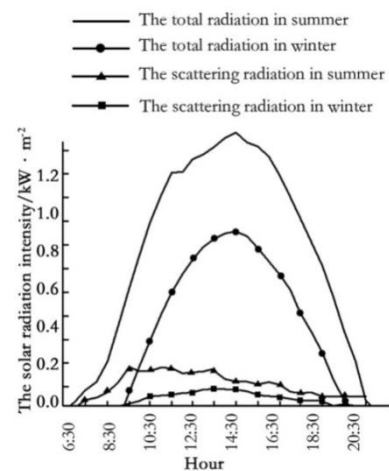

Figure 2. Solar radiation in survey day.

Obviously, the characteristic of outdoor climate in Lhasa are larger diurnal temperature range, smaller annual temperature range and intense solar radiation, which are different from inland cities. Thus, it's likely to result in different thermal sensations in Lhasa.

3. Methodology

The survey was carried out from December 2007 to February 2008, the coldest period of one year. The survey was conducted in two levels: transverse and longitudinal [27]. Transverse survey (sampling without replacement) was to select different subjects randomly. Every subject was interviewed thrice a day, in the morning, afternoon and evening between 7 a.m. and 11 p.m.. Each interviewer was to ask to fill in the questionnaires, and the environment parameters were also measured simultaneously. Longitudinal survey (sampling with replacement), was to make repeated observations on the same group of subjects for a long-time. In this study, the subjects were interviewed under the transverse survey for one day and in longitudinal survey for the next two days. All the subjects were briefed about the survey, prior to the interview in all the transverse surveys. No briefing was necessary in longitudinal surveys as they were conducted, the day after the transverse survey.

3.1. Objective and Subjective measurements

The outdoor environmental data was procured from the local meteorological station. The air temperature and relative humidity were measured by using wet and dry bulb thermometer in every family. The instruments were positioned at the height of 0.6-1.1m above the floor, close to the subjects.

The subjective questionnaires and a description of the experimental work procedure had been translated carefully into Chinese so that the occupants could follow and understand them. The subjective questionnaires included four main sections:

- Background and personal information: age, gender, height and weight.
- Building details: construction year, building style, floor area of apartment, heating system or apparatus, window form.
- Clothing and activity checklists: The checklists include different types of clothing and activities that occupants can choose from.
- Thermal, humidity and air movement sensation survey: The thermal sensation scale is the ASHRAE seven-point scale of warmth ranging from cold (-3) to hot (+3) with neutral (0) in the middle. Similarly, the seven-point scale is also used in the humidity and air movement sensation investigations.

The operative temperature (the average of air temperature and mean radiant temperature) is regarded as the evaluation index of thermal comfort in many field studies. Limited by the instruments, the globe temperature and air velocity have not been measured in this study. Therefore, the air temperature is adopted as the evaluation index in spite of its limitation without considering the effect of radiation. All the data are statistically analyzed by Excel and Statistic Package for Social Science (SPSS) software. Linear regression analysis is then applied to determine the Actual Mean Vote (AMV) for thermal sensation as a function of air temperature (t_i). The neutral temperature defines that people vote to zero and feel neither cool nor warm. The obtained linear regression equations are then solved for neutrality (AMV=0) to determine the neutral temperature. The acceptable temperature range of 80% occupants is determined with Probit regress by using the SPSS and Excel software.

3.2. Clothing and activities description

Tibetans with nomadic life prefer to the clothing style which is convenient for riding and travelling. In addition, the clothing should not only have a good thermal insulation property, but also can dissipate heat easily for the unique local climate condition with a large temperature difference between day and night, which is an obviously characteristic of the inland plateau. The style of Tibetan robes meeting the features mentioned above are shown in Figure 3 (a), the features of Tibetan robes can be summarized as follows: wide waist, long sleeves, the left front of the robe cover the right front, and laces in the right outer. The Tibetan robe is long, straight, loose, thick, and full of still air to decrease the heat loss. Moreover, the opening design of the front and the sleeve can play the role of heat dissipation. The material of Tibetan robe is mainly cotton or woolen with good air permeability. The robe usually has

interlining, and the air of the fillings becomes a static insulating layer to increase the heat preservation of clothing [28].

With the process of urbanization, international exchange and cooperation in Lhasa are also developing. The clothing of the public is more and more modern, and becomes similar to other cities. The men over 60 years old and individual middle-aged men dress in traditional clothes, while, the little boy and young adult men were jackets or suits, which are very similar to the western style. Generally speaking, the women carry more traditional obligations in the dress than the men do, it is common that the women over 40 years old wear the traditional clothes, and the elder women mostly wear the traditional clothes. The women under 30 years old with traditional clothes only account for small part. Basically, younger girls do not wear the traditional clothes (Figure 3).

The individual insulation of western garment is determined according to ASHRAE55-2004 [8], while the insulation value of Tibetan robe is similar to that described “long-sleeve long gown (thick) (0.46clo)” and “long-sleeve long wrap robe (thick) (0.69clo)” in ASHRAE55-2004 [8], and then the entire ensemble is calculated by the following equations ($1\text{clo}=0.155\text{m}^2\cdot\text{k/W}$)[29]:

$$\text{Male: } I_{cl}=0.113+0.727 \sum I_{comp}$$

$$\text{Female: } I_{cl}=0.05+0.77 \sum I_{comp}$$



Figure 3. Dressing costume of the Tibetan.

ISO7730 [30] specified that the metabolic rates of relaxed seated and sedentary activity (office, dwelling, school, laboratory) are 1.0 met and 1.2 met, respectively,

and that of standing, light activity and medium activity(domestic work) are 1.6 met and 2.0 met, respectively. When the occupants filled in the questionnaires, they were asked to engage in light activity movement (such as sitting or watching TV). The metabolic rate value used in this study is estimated to be 1.2 met as recommended by ISO7730.

4. Results and analyses

4.1. Description of residential buildings and heating equipments

The majority of existing residential buildings are low-rise in Lhasa [31]. Most of the investigated residential buildings are between 2 or 3 stories (Figure 4), being made of brick and concrete structure. Wall is mainly made of concrete block; however, the brick and stone are little used. Most of the windows are with single-layer glass and the aluminum alloy frame. 42.8% of floor area of residential buildings investigated in Lhasa is 80-120 m², below 80 m² and above 120 m² are both 28.6%, respectively. About 90% of the balconies of the residential building are enclosed. Lhasa belongs to the cold climate zone and, requires heating in the cold season. Due to lack of conventional energy (such as coal, natural gas, and oil), energy in urban areas mainly depended on hydroelectric power and geothermal power. Therefore, there are no central heating systems in Lhasa. 40% of the investigated houses do not have any heating systems or apparatus, while 60% of the houses are equipped with individual space heating units by electric heaters, stove heaters or air conditioners which are intermittence used. Therefore, 24.6% of all the recorded samples data is for heating, 75.4% without heating. 61.1% of hot-water which is used for bath or cooking in winter is heated by solar energy, but in part of houses, the hot-water is heated by electric or liquefied petroleum gas.



Figure 4. Residential building in Lhasa.

4.2. Description of occupants

44 subjects from 20 residential buildings in Lhasa were surveyed in this field study. The occupants participating in the study consisted of 25 (56.8%) males and 19 (43.2%) females. A total of 356 sets of physical measurements and questionnaires were collected, of which 203 sets from males (57.2%) and 152 from females (42.8%). The occupants' ages ranged from 7 to 70 years old with an average of 32.5 years old, and 70% of the occupants are of 25-40 years old. The average height of occupants is 160.6cm, and the average weight is 56.8kg. A summary of the background characteristics of the occupants is given in Table 1.

Table 1. Summary of the subjects.

Sample size	Age	Height/cm	Weight/kg
Mean	32.5	160.6	56.8
Standard deviation	14.0	20.1	14.7
Maximum	70	190	81
Minimum	7	120	24

4.3. Clothing

In Table 2 and Figure 5, they show that the average thermal insulation of clothing for Lhasa females is 1.63clo with the standard deviation of 0.34, however, it is 1.47clo for Lhasa males with the standard deviation of 0.29, and the mean clothing insulation for total is 1.54clo. Their clothing insulation is bigger than that of Harbin residents (1.42clo for the Harbin females, 1.33clo for the Harbin males) [14], because Harbin residences are serviced by central heating system which is more stable and higher than that of Lhasa residences in a cold season.

We divided all the data into two groups; one is in heating condition, while the other is no heating condition. The average clothing insulation of the samples in heating condition is 1.48clo, while that of the samples without heating conditions is 1.59clo. Whether female or male, and in heating or no heating conditions, the difference of clothing insulation is significance between them at the 95% confidence level by one-sample T Test (gender: $F=1.599$, $p=0.207 > 0.05$; $t=-4.746$, $p=0.001 < 0.05$. Heating means: $F=0.094$, $p=0.760 > 0.05$; $t=-2.845$, $p=0.005 < 0.05$).

Clothing level adjustment is an important adaptation process to maintain the comfort at different temperatures. Figure 6 represents the occupants' clothing level against indoor air temperature in Lhasa, each point represents the average clothing level within a temperature range of 0.5°C. Eq. (1)-(3) show the above relationship of all the samples, the male and the female. In the findings by de Dear [32] and Mui [33], the regressed equation between clothing insulation and operative temperature is Eq. (4) and (5), respectively. Heidari [34] showed the relationship between average indoor air temperature and clothing value (Eq. (6)).

$$CL = 1.875 - 0.035 t_i \quad (R^2 = 0.547) \quad (\text{Total}) \quad (1)$$

$$CL = 1.710 - 0.024 t_i \quad (R^2 = 0.296) \quad (\text{Male}) \quad (2)$$

$$CL = 2.086 - 0.037 t_i \quad (R^2 = 0.396) \quad (\text{Female}) \quad (3)$$

$$CL = 1.730 - 0.04 t_o \quad (R^2 = 0.18) \quad (4)$$

$$CL = 1.760 - 0.04 t_o \quad (R^2 = 0.21) \quad (5)$$

$$CL = 1.868 - 0.047 t_i \quad (R^2 = 0.38) \quad (6)$$

Where CL is clothing insulation value (clo), t_i is indoor air temperature (°C), t_o is indoor operative temperature (°C).

By comparing with the above equations, the results of this study are similar to that of other field studies. The changing of the females clothing with the indoor air

temperature variation in this study is more sensitive than the males', that is to say, the females adjust their clothing in time with the change of indoor air temperature.

Table 2. Statistics of clothing insulation for different groups.

Clothing /clo	Female	Male	Heating	No heating	Total
Mean	1.63	1.47	1.48	1.59	1.54
Standard deviation	0.34	0.29	0.31	0.31	0.33
Maximum	2.46	2.19	2.39	2.46	2.46
Minimum	0.69	0.71	0.69	0.71	0.69

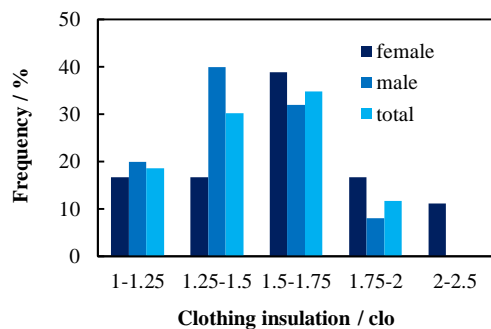

Figure 5. Frequency distribution of clothing insulation.

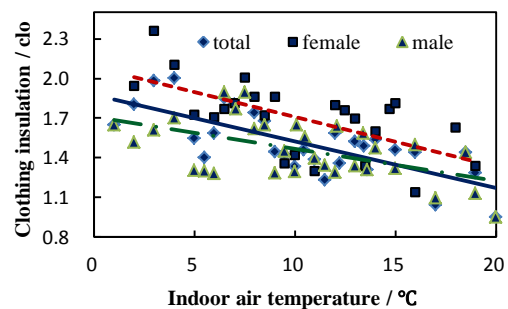

Figure 6. The relationship between indoor air temperature and clothing insulation.

4.4. Outdoor and indoor temperature

As shown in Figure 7, during the survey period (from December 2007 to February 2008), the outdoor daily mean air temperature ranged from -6.1°C to 8.3°C , with an average of 1.7°C . But the air temperature of a single day (took 28-29, December 2007 as a typical day) fell within -5.7°C and 15.5°C (Figure 8). It is possible to observe that the temperature difference in a single day is 21.2K , nevertheless, the daily mean air temperature is relatively low.

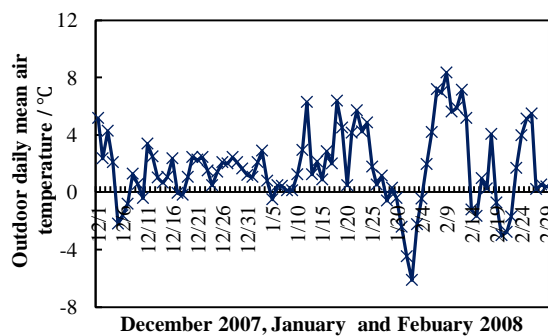

Figure 7. Frequency distribution of outdoor daily mean air temperature.

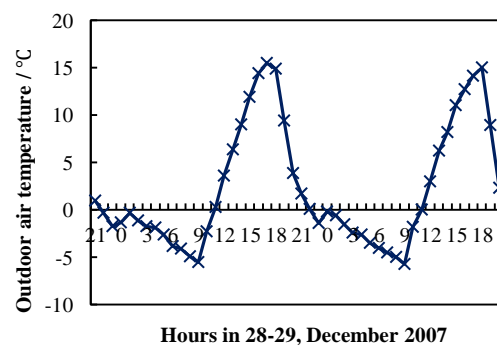

Figure 8. Frequency distribution of outdoor air temperature in typical day.

The frequency distribution of the indoor air temperatures to which the subjects were exposed is shown in Figure 9. The indoor air temperature of residential buildings in Lhasa fell within 0.6°C and 21°C , with an average value of 10.9°C , and standard

deviation of 3.95. Meanwhile, 64.2% indoor air temperature distributes from 10°C to 15°C, and the maximum proportion (54%) fell on 11°C. It indicates that the range of indoor air temperature is wider, and unstable indoor air temperature in residential buildings in winter has an adverse effect on occupants' thermal comfort.

4.5. Thermal sensation vote

Figure 10 shows frequency distribution of overall actual thermal sensation vote of selected buildings. The mean thermal sensation vote of residential building in winter in Lhasa is -1.27, a heavy bias towards the “cold” section of the seven-point scale. 21.9% of the respondents feel cool (-2) in their home, while 14.5% feel very cold (-3), and only 24.9% feel neutral (0). 62.8% of the votes recorded range from -1 (slightly cool) to +1 (slightly warm).

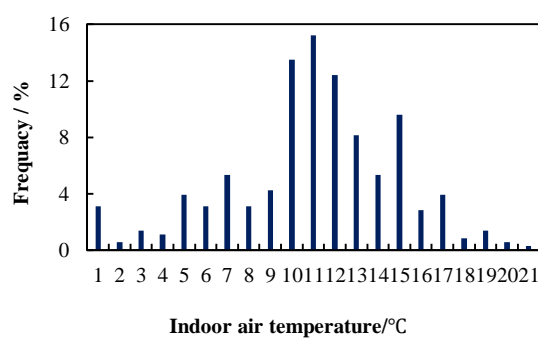

Figure 9. Frequency distribution of indoor air temperature in residential buildings in Lhasa.

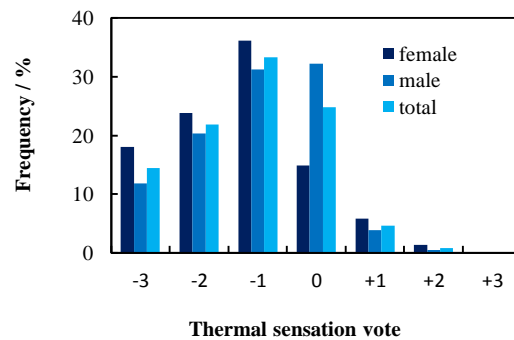

Figure 10. Distribution of overall actual thermal sensation vote.

By using decompression chamber to simulate up to 2300m altitude, Haiying Wang et al. [16] reported that, in the normobaric environment, thermal sensations for males and females were almost the same. As air-pressure decreased, females were more prone to feel cooler than males do. When the air-pressure is 0.75 atm, the mean thermal sensation vote (MTSV) of females is averagely 0.15 lower than that of males. In low-pressure plateau climate of Lhasa (above 4000m), it is also observed that the proportion of the votes between the “very cold” and “slightly cool” regions from the female occupants is higher than that of the male occupants. The result is accordant to Haiying Wang’s studies. The difference of thermal sensation votes between the female and male is significant at the 95% confidence level by T test ($F=0.050$, $P=0.824$; $T=3.522$, $P=0.001$).

4.6. Thermal Neutral temperature

The fitted lines, the linear regression equations and neutral temperature in the present study are shown in Figure 11-12 and Table 3. The neutral temperature of all the occupants is 19.3°C, as shown in Table 3. The linear regression equations in Table 3 are significant at the 95% confidence level by F test ($P<0.001$), indicating strong linear correlation between AMV and indoor temperature. the regression coefficients of those linear regression equations are significant at the 95% confidence level by T test ($P<0.001$), suggesting that the developed regression equation could give good indications for estimation of thermal sensation.

The slope (gradient coefficient) of the regression line can be used to evaluate the sensitivity of the occupants to the air temperature variation. Some studies [35, 36] have found that females are more sensitive and tend to be cooler in cold environment for the same clothing insulation level. In our study, it is found to be 0.1090/°C for the Lhasa females, 0.1378/°C for the Lhasa males, which shows that thermal sensation of Lhasa females changing with the temperature variations were less sensitive than that of Lhasa males. We think that one possible reason is that the females adjust their clothing levels more swiftly according to the indoor temperature shown in Figure 6, resulting in insensitivity to indoor temperature changes.

We divided all the samples data into two groups according to heating and no heating in the houses, and analyzed it by liner regression. The results are shown in Figure 11 (a, b) and Table 3. The neutral temperature of samples with heating is 16.2°C, and that of samples without heating is 20.2°C, as shown in Table 3, which indicates that the neutral temperature of occupants in houses without heating devices is higher than that of houses with heating devices.

Table 3. Regression equation and neutral temperature.

	Regression Equation	Correlation coefficient (R)	Neutral temperature /°C
Heating	$AMV = 0.1470 t_i - 2.3772$	0.8338	$t_i = 16.2$
No heating	$AMV = 0.1374 t_i - 2.7808$	0.7997	$t_i = 20.2$
Total	$AMV = 0.1292 t_i - 2.4953$	0.8357	$t_i = 19.3$

Where: AMV is actual mean vote of thermal sensation and t_i is the indoor air temperature.

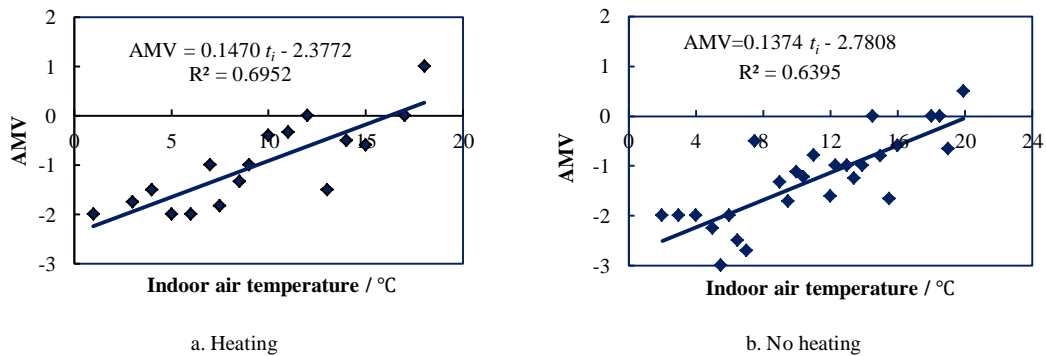

Figure 11. Linear regression calculation based on AMV versus indoor air temperature.

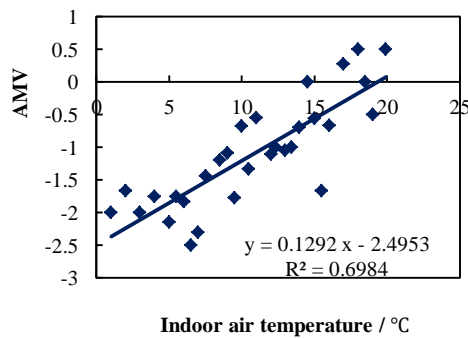

Figure 12. Linear regression calculation based on AMV versus indoor air temperature for total.

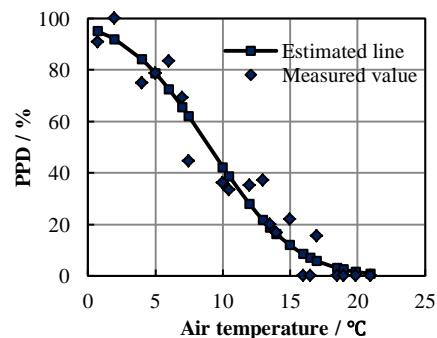

Figure 13. Thermal acceptability.

4.7. Thermal acceptability

ASHRAE Standard 55 specifies the conditions in which 80% or more of the occupants will find the environments thermally acceptable. It is a common assumption that a vote outside the three central categories (-1, 0, 1) of the ASHRAE scale is an expression of dissatisfaction (unacceptable). Therefore, the resulting percentage of people's dissatisfaction (PPD) from occupants' votes (-2, -3, +2, +3) in each 0.5°C bin was plotted as a function of indoor air temperature. The Probit regression percentage curve of thermal unacceptable on air temperature in winter is depicted in Figure 13. When the percentage of people's dissatisfaction is equal to 20%, the lower limit of acceptable air temperature of 80% occupants can be calculated as 13.3°C. This finding indicates that occupants in Lhasa could accept wider temperature range. The Probit regression equation is as follow:

$$\text{Probit}=\Phi(1.784-0.198t_i)$$

5. Discussion

5.1. Comparison with other cities

In order to understand the winter indoor thermal environmental conditions in China well, five cities are chosen to compare in terms of thermal comfort investigation. They are Lhasa, Xi'an, Nanyang, Jiaozuo and Harbin. The five cities are in different typical climate regions of China (Figure 1). Although the summer climates in these cities are quite different, but cold and dry conditions in winter is their common characteristics.

Central heating systems and individual heating units are usually used by occupants in cold season. Table 4 demonstrates that the percentages of houses equipped with central heating systems in Harbin, Xi'an, Jiaozuo and Nanyang are 100%, 96.5%, 78.7% and 41.3%, respectively. Houses in Lhasa use individual space heating units such as electric heater. Because the majority of houses of Harbin and Xi'an used the central heating systems, we find that the mean indoor air temperature in the two cities is over 20°C, which is the highest one among the cities. On account of intense solar radiation in Lhasa, although the mean outdoor air temperature in Lhasa is 1.4°C, about 4.5K lower than that of Nanyang and Jiaozuo during investigation, but the mean indoor air temperature in Lhasa is 10.9°C, which is similar to that of Nanyang and Jiaozuo which used individual heating units to warm their houses in winter. However, the mean indoor temperature in Lhasa is lower than that of houses which equipped with central heating system. It reveals that the indoor air temperature is affected not only by outdoor climate and space heating system or apparatus, but also by solar radiation level.

5.2. Comparison with previous field studies

Table 4 and table 5 show the findings of different field studies of thermal comfort in winter. The neutral temperature of Lhasa occupants is 19.3°C, which is similar to that of Jiaozuo and Harbin, higher than Xi'an and Nanyang's results.

The slope between the actual thermal comfort vote and the air temperature is 0.1292/°C, which is lower than that of the San Francisco, Montreal, Kalgoorlie, and

Harbin, higher than Xi'an's and Jiaozuo's results. The slope presents the subjects' thermal sensitivity to air temperature variations. In general, the subjects with the Chinese cultural background have lower neutral temperature and are less sensitive to air temperature variations than those of the other cultures with higher neutral temperature, possibly due to the heavier clothing insulation level in winter.

In spite of the higher neutral temperature of Lhasa occupants, the acceptable temperature range is relatively wider. The lower limit of 80% occupants in Lhasa can accept the air temperature of 13.3°C, which is lower than that of Xi'an (16.4°C) and Harbin (18.0°C), but higher than that of Nanyang (11.2°C) and Jiaozuo (11.6°C).

Table 4. Statistics of environmental parameters among different cities in China.

City	T _{in}		T _{out}	Clothing (clo)		Air pressure (mbar)	Space heating	Climate type	
	CH	IH		CH	IH				
Lhasa	Mean		10.9	1.4		1.50			
	Standard deviation		3.95	5.5		0.29	650	IH	Plateau climate
	Maximum		21	15.8		2.20			
	Minimum		0.6	-12.7		1.03			
Xi'an[37]	Mean	20.3		-2.5	0.89				
	Standard deviation	2.3		3.8	0.24		978.7	96.5% CH	Cold climate
	Maximum	24.3		-14.9	1.65				
	Minimum	12.8		3.8	0.45				
NanYang[38]	Mean	16.2	9.9	5.7	1.14	1.41			
	Standard deviation	1.97	3.2	-	0.12	0.28	1010	41.3% CH 58.7% IH	Hot in summer and cold in winter
	Maximum	21	17.5	-	1.66	2.2			
	Minimum	12.5	4	-	0.86	0.86			
JiaoZuo[24]	Mean	18.5	10.6	5.5	1.15	(1.5)			
	Standard deviation	2.6	2.2	4.3	0.38	0.24	1017	78.8% CH 21.2% IH	Cold climate
	Maximum	24	17.1	17.3	2.60	2.37			
	Minimum	9.9	6.0	-2.2	0.45	0.92			
Harbin[17]	Mean	20.1		-9.9	(1.4)				
	Standard deviation	2.43			0.28		1001	100% CH	Severe cold climate
	Maximum	25.6			2.08				
	Minimum	12.0			0.81				

Note: The insulations of the chairs (0.15clo) are included in parenthesis. CH and IH are the space heating pattern of residential building. CH refers to central heating system, and IH refers to individual space heating devices or no heating apparatus.

Table 5. Statistical results of field studies in winter.

	Actual Mean Vote equation	Correlation Coefficient (R)	Neutral temp. t_o (ET*)	Preferred temperature	80% acceptable temp.	Clothing (clo)
Shiller[40] San Francisco	$AMV = 0.26 \times ET^* - 5.83$	0.9274	(22.0)		20.5-24.0	0.58
Donnini[41] Motreal	$AMV = 0.49 \times t_o - 11.69$	0.9899	23.1 (22.6)	22	21.5-25.5	0.87
Cena[42] Kalgoorlie	$AMV = 0.21 \times t_o - 4.28$	0.8426	20.3		-	0.7
de Dear[43] Brisbane	-	-	24.2 23.8 22.6			0.41-0.52 0.37-0.53 0.46-0.62
Lhasa	$AMV = 0.13 \times t_i - 2.4953$	0.8357	19.3(t_i)		≥ 13.3	1.50
Xi'an[37]	$AMV = 0.06 \times t_o - 1.092$	0.2306	17.0	17.4	16.4-24.0	0.89
NanYang[38]	$AMV = 0.15 \times t_o - 1.976$	0.7166	13.6	14.5	11.2-16.8	1.14-1.41
Jiaozuo[24]	$AMV = 0.09 \times t_o - 1.822$	0.8526	19.4	21.0	11.6-24.2	1.15-1.51
Harbin[17]	$AMV = 0.30 \times t_o - 6.506$	0.8722	21.5	21.9	18.0-25.5	1.37

Notes: AMV refers to actual mean vote. ET* is the new effective temperature, t_o is operative temperature, t_i is air temperature.

5.3. Thermal adaptation

In conclusion, the thermal comfort of Lhasa occupants is more different from the findings of other field studies. The possible reasons are local unique plateau climate and the adaptation of local people. When adaptive opportunities are available and effective, occupants will be able to achieve thermal comfort in terms of psychological and behavioural adaptation [29]. People who live in free-running buildings can have more opportunities to control over their environment to suit themselves [39]. On account of living in the plateau for thousands of years, Lhasa occupants have adapted to the typical natural environment psychologically, physiologically, and behaviourally.

5.3.1. Psychological expectations

The occupants of Lhasa have higher thermal expectation. The possible explanation may be as follows. Yanfeng Liu reported that, when the outdoor average air temperature of Lhasa was -0.6°C , the indoor mean daily air temperature of southern and northern space without heating devices were 18.0°C and 7.4°C , respectively [44]. A relatively warm environment in southern space in Lhasa was built due to the intense solar radiation in winter. As a result, people who stay in the southern space are satisfied with their thermal environment. But when they go into or out of northern space such as a kitchen or a toilet with lower temperature, it is possible to produce heavier cold stress physiologically and psychologically caused by the temperature difference between southern and northern space, and as well as the psychological

expectations caused by the thermal experience in the southern space. Therefore, when people move out of the warm south-side or sun-spaces, they feel cold discomfort in the other colder regions of the house, and are likely to be more critical of those.

The distribution of indoor air temperature between heating and no heating is shown in Figure 14. It demonstrates that the indoor air temperature in the houses between heating and no heating is significantly different by T test ($P=0.001 < 0.05$).

The mean indoor air temperature in the houses with the heating devices is lower than that of houses without heating devices. The possible reason is that the number of samples with heating devices is much less. However, the neutral temperature of the occupants in the heating houses (16.2°C) is lower than that of the occupants without heating (20.2°C). It is possible that the psychological factor plays a role in the process of thermal sensation. When there are space heating units with electric heaters or stove heaters in the houses, although there is little function on improving the indoor air temperature, it alleviates the thermal expectations due to environmental control equipments installed in houses.

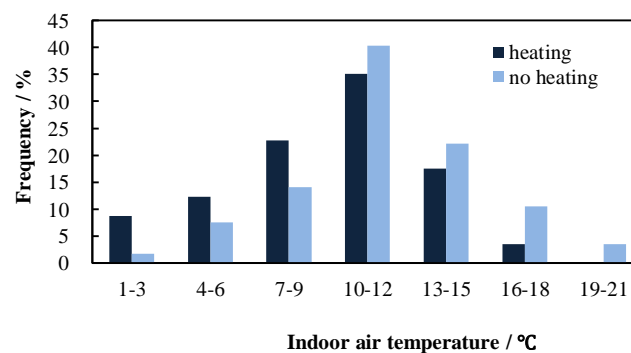

Figure 14. Frequency distribution of indoor air temperature in the houses between heating and no heating.

5.3.2. Acclimatization

The air pressure in Lhasa is two-thirds of the standard air pressure. At low air pressure condition, the increment of evaporative heat transfer was larger than the decrement of convective heat transfer. Radiant heat transfer between human body and environment was not affected by hypobaric exposure, while the respiratory heat transfer changed little [16]. Therefore, compared with the normal air pressure, the heat loss of human body in low air pressure obviously increased. The lower air pressure, the greater the heat loss. It explained why people tended to feel cooler under lower air pressure. Thus they expected a warmer thermal environment.

5.3.3. Behavioural adaption

Firstly, the indoor air temperatures in southern spaces in Lhasa could meet the requirements of human thermal comfort even without the heating system because of the rich solar radiation (Figure 2)[44]. Therefore, the daily living activities of Lhasa residents are concentrated on the southern space (the living room). Moreover, the living room also possessed other functions such as the dining room or the bedroom in some traditional houses.

Secondly, the Lhasa residents wear heavier clothing to resist cold; it can be found that the clothing insulation of Lhasa occupants is the maximum one in comparison with other field studies. Simultaneously, to adapt to the varying thermal regimes, Tibet robes offer a lot of flexibilities to change the micro-climate around the body. For example, on the sunny day, people usually wear the left sleeve, and drape the right sleeve from the shoulder to the front of the chest. Until the sunset, and they wrap tightly the robes. Thus a unique dressing habit of Tibetans is to take off the right sleeve (Figure 3), and the occupants have adaptively used clothing in response to the temperature change.

Thirdly, affected by nomadic life style and alpine climate, the Tibetans develop their dietary custom based on beef and mutton, buttered tea and barley liquor. The high-calorie and high-protein diet can maintain a higher metabolic, so that people can produce more heat to resist cold.

6. Conclusions

The main objectives of this study were to investigate the indoor thermal environment conditions and occupants' thermal comfort sensation in residential building in China. A total of 356 sets of physical measurements and questionnaires were collected from 44 occupants in 20 houses located in Lhasa with the plateau continental climate zone from December 2007 to February 2008. The main results of the study are as follows:

- Most of the residential buildings investigated were between 2 or 3 stories. Due to lack of conventional energy (such as coal, natural gas and oil), there were no central heating systems in Lhasa. About 60% of the houses investigated were equipped with individual space heating units by electric heaters stove heaters or air conditioners which were intermittence used, while 40% without any heating systems or apparatus.
- The average thermal insulation of clothing was 1.63clo for Lhasa females, 1.48clo for Lhasa males, and with a mean clothing insulation of 1.54clo for total sample. The average clothing insulation of the samples with heating devices was 1.48clo, while that of the samples without heating devices was 1.59clo. Whether female or male, heating or without heating, the clothing insulation difference between them was significant at the 95% confidence level by SPSS analysis.
- The indoor air temperature of residential buildings in Lhasa fell within 0.6°C and 21°C, with an average value of 10.9°C. Meanwhile, 64.2% indoor air temperature distributed from 10°C to 15°C. The range of indoor air temperature was wider, and unstable indoor air temperature in residential buildings in winter had an adverse effect on occupants' thermal comfort.
- The neutral temperature of samples with heating was 16.2°C, that of samples without heating was 20.2°C, and that of the total samples was 19.3°C.
- The lower limit of acceptable air temperature for 80% occupants in Lhasa was 13.3°C. This finding indicates that occupants in Lhasa who have acclimated to the plateau cold climate could accept wider thermal environments.

- Lhasa occupants have adapted to the typical natural environment from psychological expectation, physiological acclimatization, and behavior adaption.

The results of this field survey and measurement study can be used to design a low energy consumption system with consideration of occupant thermal comfort in plateau climate zone of Lhasa.

Acknowledgements

The work is supported by National Key Technology Support Program (Project No. 2014BAJ01B01). The authors wish to thank profoundly Michael Humphreys of Oxford Brooks University, UK, and Richard de Dear, Faculty of Architecture, Design and Planning, University of Sydney for their constructive comments about data analysis, guidance, e-mails, and papers. The authors also would like to thank the members from green building research center of Xi'an University of Architecture and Technology for assisting field experiments, and all the 44 subjects for giving their comfort votes patiently during the surveys.

References

- [1] P.O. Fanger, 1970. Thermal Comfort. Copenhagen: Danish Technical Press.
- [2] J.F. Nicol, M. Humphreys, 2010. Derivation of the adaptive equations for thermal comfort in free-running buildings in European standard EN15251. *Building and Environment*, 45, pp 11-17.
- [3] de Dear RJ, Brager GS, 2002. Thermal comfort in naturally ventilated buildings: revisions to ASHRAE Standard 55. *Energy and Buildings*, 34(6), pp 549-561.
- [4] CEN Standard EN15251, 2007. Indoor environmental input parameters for design and assessment of energy performance of buildings-addressing indoor air quality, thermal environment, lighting and acoustics. Brussels: Comite' Europe'en de Normalisation.
- [5] ANSI/ASHRAE. Standard 55-2004, Thermal environmental conditions for human occupancy. Atlanta: American Society of Heating, Refrigerating and Air-Conditioning Engineers, Inc.
- [6] G.M. Rapp, 1970. Convective mass transfer and the coefficient of evaporative heat loss from human skin. in: J.D. Hardy, A.P. Gagge, J.A.J. Stolwijk (Eds.), *Physiological and Behavioral Temperature Regulation*, Thomas, Springfield, IL, pp 55-81.
- [7] MK. Iwajlo, 1999. Heat and mass exchange processes between the surface of the human body and ambient air at various altitudes. *International Journal of Biometeorology*, 43, pp38-44.
- [8] Guodan L., 2008. Study on Human Thermal Comfort Within Lower-pressure Environment of Asymptomatic Altitude Reaction. PhD. Xi'an University of Architecture and Technology (in Chinese).
- [9] P. Golja, A. Kacin, et al, 2004. Hypoxia increases the cutaneous threshold for the sensation of cold. *European Journal of Applied Physiology*, 92, pp 62-68.
- [10] P Golja, IB. Mekjavic, 2003. Effect of hypoxia on preferred hand temperature.

Aviation, Space, and Environmental Medicine, 74, pp 522-526.

- [11] J.C. Launay, Y. Besnard, et al, 2006. Acclimation to intermittent hypobaric hypoxia responses to cold at sea level. *Aviation, Space, and Environmental Medicine*, 77, pp 1230-1235.
- [12] U.L. Malanda, J.P.H. Reulen, et al, 2008. Hypoxia induces no change in coetaneous thresholds for warmth and cold sensation. *European Journal of Applied Physiology*, 104, pp 375-381.
- [13] B Fowler, H. Prlic, 1995. A comparison of visual and auditory reaction time and P300 latency thresholds to acute hypoxia. *Aviation, Space, and Environmental Medicine* , 66, pp 645-650.
- [14] J.H. Mackintosh, D.J. Thomas, et al, 1988. The effect of altitude on tests of reaction time and alertness. *Aviation, Space, and Environmental Medicine*, 59, pp 246-248.
- [15] O. Hideo, K. Satoru, et al, 1991. The effects of hypobaric conditions on man's thermal responses. *Energy and Buildings*, 16, pp 755-763.
- [16] Haiying W, Songtao H, et al, 2010. Experimental study of human thermal sensation under hypobaric conditions in winter clothes. *Energy and Buildings*, 42, pp 2044-2048.
- [17] Zhaojun W, 2006. A field study of the thermal comfort in residential buildings in Harbin. *Building and Environment*, 41, pp 1034-1039.
- [18] Han J., Zhang G., et al, 2007. Field study on occupant's thermal comfort and residential thermal environment in a hot-humid climate of China. *Building and Environment*, 42, pp 4043-4050.
- [19] Bin C., Yingxin Zh., et al, 2011. Field study of human thermal comfort and thermal adaptability during the summer and winter in Beijing. *Energy and Buildings*, 43(5), pp 1051-1056.
- [20] Yufeng Zh., Jinyong W., et al, 2010. Thermal comfort in naturally ventilated buildings in hot-humid area of China. *Building and Environment*, 45, pp 2562-2570.
- [21] Mao Y., Jia-ping L., et al, 2007. Research on indoor thermal environment of residential buildings in summer in Jiaozuo. *Journal of Harbin institute of technology*, 14(7), pp 206-208.
- [22] W. Yang, G. Zhang, 2008. Thermal comfort in naturally ventilated and air-conditioned buildings in humid subtropical climate zone in China. *International Journal of Biometeorology*, 52, pp 385-398.
- [23] Jie H., Wei Y., et al. 2009. A comparative analysis of urban and rural residential thermal comfort under natural ventilation environment. *Energy and Buildings*, 41, pp 139-145.
- [24] Haiyan Y., Liu Y., 2011. Field study on occupant thermal comfort of residential building in winter in Jiaozuo. *Heating ventilation & Air conditioning*, 41(11), pp 119-126.
- [25] Zhaojun W., Lin Zh.,et al, 2011. Thermal responses to different residential

environments in Harbin. *Building and Environment*, 46, pp 2170-2178.

- [26] Yanfeng L., Jiaping L., et al, 2008. Measuring study of passive solar house fort traditional dwelling building in Lhasa area. *Acta energiae solaris sinica*, 29(4), pp 391-394 (in Chinese).
- [27] J. Fergus Nicol, Iftikhar A. Raja, 1997. Indoor thermal comfort: the Pakistan study. *Energy for Sustainable Development*, 5(1), pp50-60.
- [28] Hualing Zh., Jinghan Z., et al, 2010. Stack effect of structural design of traditional clothing. *light textile industry and technology*, 39(5), pp 53-55 (in Chinese).
- [29] McIntyre D.A, 1980. *Indoor Climate*. London: Applied Science Publishers Ltd..
- [30] ISO7730:2005. Moderate thermal environments. Determination of the PMV and PPD indices and specification of the conditions for thermal comfort. 2nded. Gevena, Switzerland: International Organization for Standardization.
- [31] Yuanzhe L., 2004. Feasibility study on solar energy heating in the residential building in Lhasa. *Solar energy*, 4, pp 36-38.
- [32] de Dear R, Schiller BG, et al, 1998. Developing an adaptive model of thermal comfort and preference. *ASHRAE Transactions*, SF-98-7-3:4106, RP-884.
- [33] Kwok Wai Horace Mui, Wai Tin Daniel Chan, 2003. Adaptive comfort temperature model of air-conditioned building in Hong Kong. *Building and Environment*, 38, pp 837-852.
- [34] Shahin Heidari, Steve Sharples, 2002. A comparative analysis of short-term and long-term thermal comfort surveys in Iran. *Energy and Buildings*, 34, pp 607-14.
- [35] Sami Karjalainen, 2007. Gender differences in thermal comfort and use of thermostats in everyday thermal environments. *Building and Environment*, 42, pp 1594-1603.
- [36] K.C.Parsons, 2002. The effects of gender, acclimation state, the opportunity to adjust clothing and physical disability on requirements for thermal comfort. *Energy and Building*, 34, pp593-599.
- [37] Qian Y., 2010. Study on the Indoor Thermal Comfort in the Cold Zone. Master of Engineering. Xi'an University of Architecture and Technology, Xi'an (in Chinese).
- [38] Junge L., 2007. An adaptive thermal comfort model for hot summer and cold winter context. Master of Engineering. Xi'an University of Architecture and Technology, Xi'an (in Chinese).
- [39] J.F. Nicol, M. A. Humphreys, 2002. Adaptive thermal comfort and sustainable thermal standards for buildings. *Energy and Buildings*, 34, pp 563-572.
- [40] G E Schiller, E A Arens, et al, 1998. A field study of thermal environment in office buildings. In: *ASHRAE Trans.*, 94(2), pp 280-308.
- [41] G Donnini, J Molina, et al, 1996. Field study of occupant comfort and office thermal environments in a cold climate. In: *ASHRAE Trans.*, 102(2), pp 795-802.

- [42] K Cena, R J De dear, 1999. Field study of occupant comfort and office thermal environments in a hot, arid climate. In: ASHRAE Trans., 105(2), pp 204-217.
- [43] R J De dear, A Auliciems, 1985. Validation of the predicted mean vote model of thermal comfort in six Australian field studies. In: ASHRAE Trans., 91(2B), pp 452-468.
- [44] Yanfeng L., Dengjia W., et al, 2010. Measurement Study on influence factors of building indoor thermal environment in winter in Lhasa. Building science, 26(8), pp 23-26 (in Chinese).

Proceedings of 8th Windsor Conference: *Counting the Cost of Comfort in a changing world* Cumberland Lodge, Windsor, UK, 10-13 April 2014. London: Network for Comfort and Energy Use in Buildings, <http://nceub.org.uk>

Challenges in designing for comfort – Comfort and energy use characterization in residential apartments

E. Rajasekar, R. Soumya, Rajan Venkateswaran

Center for Excellence and Futuristic Developments, B&F (IC), L&T Construction, India

Abstract

This article presents the results of a thermal comfort investigation carried out in a residential gated community located in a hot-humid climate. The study comprises of real-time field monitoring of thermal comfort in representative apartment units and assessment of the utility and cooling energy consumption in these residences. Utility energy consumption data of the residences for one year period was obtained and a survey was administered to identify the trend of air-conditioner use. The results are summarized and used to validate a simulation model. The pattern of comfort and energy use variation across the gated community was analysed. The variation in cooling energy consumption and its relevance to the discomfort severity across residences was analysed. This article presents the challenges in ensuring optimal thermal comfort for all units in such buildings and discusses the possible commercial value of thermal comfort.

Keywords: Thermal comfort, residential buildings, adaptive criteria, cooling energy, field studies

1 Introduction

In naturally ventilated buildings, indoor thermal comfort is determined by a multitude of factors which includes design configurations, envelope characteristics and outside boundary conditions. The physical indoor thermal conditions have been found to relate strongly with the ambient thermal stimuli as observed by Kruger & Givoni (2004, 2008, 2011), Shastry et al (2012) and Udaykumar et al (2013). Apart from the physical parameters, the comfort perception and thermal expectations are known to be driven by psychological factors. These aspects remained the focal point of studies reported by Humphreys (1981), Brager & de Dear (1998), Humphreys & Nicol (1998), Nicol (2004), Indraganti (2010) and Rajasekar & Ramachandraiah (2010). It can be postulated that if these physical and psychological stimuli are appropriately tuned, thermal comfort can be achieved to a greater extent of the occupied duration without resorting to mechanical conditioning. It is evident from Humphreys & Nicol (1998) that *if the adaptive processes are working satisfactorily, the kind of temperatures and other thermal parameters in the buildings they are living in should have suited their requirements.*

The energy consumption for comfort conditioning can be theoretically equated to the magnitude of indoor thermal discomfort. Abreu et al. (2010) found that approximately 80% of household electricity use can be explained within the two patterns of persistent daily routines and patterns of consumption or baselines typical of specific weather and daily conditions. Santin et al. (2009) observed that occupant

characteristics and behaviour influences energy use by 4% while building characteristics influence energy use by 42%. However the authors noted that some occupant behaviour is determined by the type of dwelling or HVAC systems and, therefore, the effect of occupant characteristics might be larger than expected. Especially in the case of apartments which accommodate a number of typical residences with varying outside boundary conditions in every floor plate, the effectiveness of adaptive process is perhaps bound by the constraints that may vary widely from one residence to the other. One of the recent studies (Khaled el-deeb et al., 2012) showed that common building forms and urban patterns do not always yield the expected reduction of energy consumption.

In India, a substantial share of urban residential settlement is catered condominium style gated communities. Given the trend of depleting renewable energy sources, the aspects of thermal discomfort severity and energy relating to comfort conditioning have increasingly become the focal points in the residential building sector. A study conducted by Viginie & Michael (2007) shows that in India, on an average the household per-capita energy consumption grow at the rate of 8.2% a year and relative to 2013, the consumption will be about 4 times higher by 2030. In this context, the present study deals with thermal comfort and energy consumption pattern across eight condominiums in a gated community. The objectives of the study are (i) to investigate the thermal comfort characteristics of residential units in condominiums and to analyse the factors that influence it (ii) to study in real-time, the variations in actual and simulated cooling energy use pattern and to investigate the viability of different methods for improving comfort in such residential developments.

2 Details of the study

Chennai (13°N, 80.3°E) located in the east cost of India represents a typical hot humid climate. The study pertains to a gated community encompassing 650 residential units distributed in 6 apartment blocks which are 14 floors high. There are 3 apartment types; type I, type II and type III with floor areas 120 sq. m., 160 sq. m. and 186 sq. m. respectively (fig 1(a)).

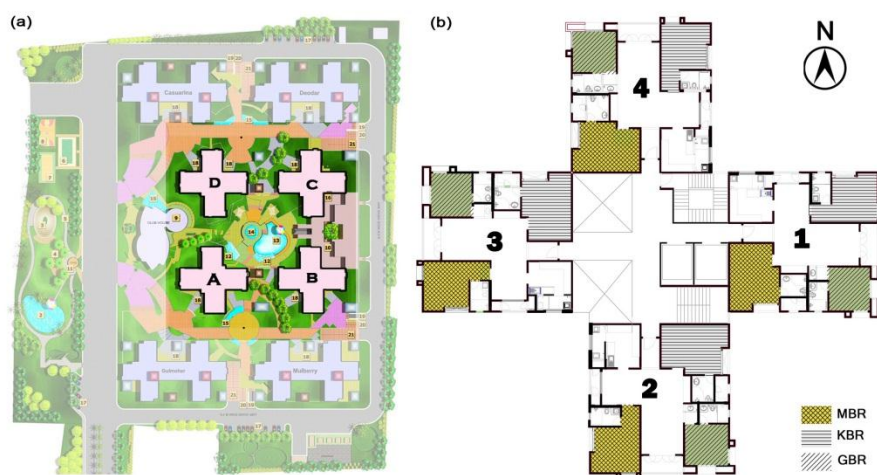

Figure 1. (a) Site layout (b) Typical floor plan of type III apartment block

Based on a pilot study and a climate and sun-path analysis, a field monitoring setup was established in three residential units located at the 13th floor and continuous measurements were made for one year duration. The present study focuses on type III apartments which are termed premium 3-bedroom units catering to higher middle

income group of people (fig 1(b)). They enclose three bedrooms – the master bedroom (MBR, 21 sq. m), kids’ bedroom (KBR, 15 sq. m) and guest bedroom (GBR, 11 sq. m) – living-cum-dining area (33sq.m.) and kitchen (13.5 sq.m.). The envelope is made of 150 mm thick reinforced concrete wall (U-value of 3.77 W/m²K) with smooth plastered white finish on both the sides (absorptivity of 0.3). Calculated heat capacity of the envelope is 86.4 Wh/m²C and thermal time constant is 9.7 hours.

3 Real-time measurements and Utility power consumption

Indoor thermal comfort variations were recorded using 2 numbers of Delta OHM thermal comfort meters (Accuracy $\pm 0.35^{\circ}\text{C}$, $\pm 2.5\%$ RH, $\pm 0.05\text{m/s}$ for 0-1m/s air velocity and $\pm 0.15\text{m/s}$ for 1-5m/s air velocity), 2 numbers of Delta OHM 16 channel data loggers with T-type thermocouples (accuracy $\pm 0.5^{\circ}\text{C}$), 8 numbers of Supco LTH – Temperature, RH loggers (accuracy $\pm 1^{\circ}\text{C}$, $\pm 2\%$ RH) and 3 numbers of Supco LT2 – Temperature loggers (accuracy $\pm 1^{\circ}\text{C}$). Using this measurement setup indoor air temperature (T_{in}), mean radiant temperature (T_r), relative humidity (RH), air velocity (V_a), inside and outside surface temperature of wall (T_s) were recorded at 10 minutes interval.



Figure 2.(a) Typical indoor instrument setup (b) Mini Weather station

From the measured thermal parameters, comfort in terms of Fanger’s predicted mean vote (PMV) was estimated for a clothing value (clo) of 0.8 and metabolic rate of 1.2. In addition two heat flux plates (accuracy $43 \mu\text{V/W/m}^2$) connected with LSI Lastem data logging system were used for envelope heat flow measurements. Outdoor monitoring setup - a watchdog mini-weather station (installed at 3 m height above the 14th storey) recorded air temperature, relative humidity, wind velocity and direction and rainfall intensity. These measurements were made for one year duration in three un-occupied residential units. Fig. 2 shows some of the snap shots of the measurement setup. In addition, T_{in} and RH data were collected from 10 occupied residences using Supco LTH – Temperature, RH loggers for comparative analysis.

Utility power consumption over a period of 2 years was obtained for all the occupied residences in the gated community from the electricity regulatory authority. A subjective survey on utility power consumption was administered with representative condominiums (sample size of 100 units) regarding the capacity and usage pattern of air-conditioners and other major electrical equipment. Data on the lighting fixtures and their lighting power densities were also collected. The questionnaire used for this purpose is presented as appendix A. Fig. 3 and 4 provide the details and pattern of air-conditioner operation obtained through the subjective surveys. Peak operation of air-conditioner was found to be during the months of May, June and July (summer). This study hence focused on the thermal discomfort and cooling energy consumption pattern pertaining to the summer months. A large non-uniformity in the pattern of air-conditioner usage and set-point temperatures were evident from the surveys. The

details of it are depicted in the form of a histogram in figs. 3(a) and (b). The data obtained relating to occupancy levels per residential unit ($\mu=3.5$), set temperature ($\mu=23.5^{\circ}\text{C}$), occupancy pattern and hours of air-conditioner operation ($\mu=6$ hours) were considered as inputs for the simulation studies discussed in section 5.

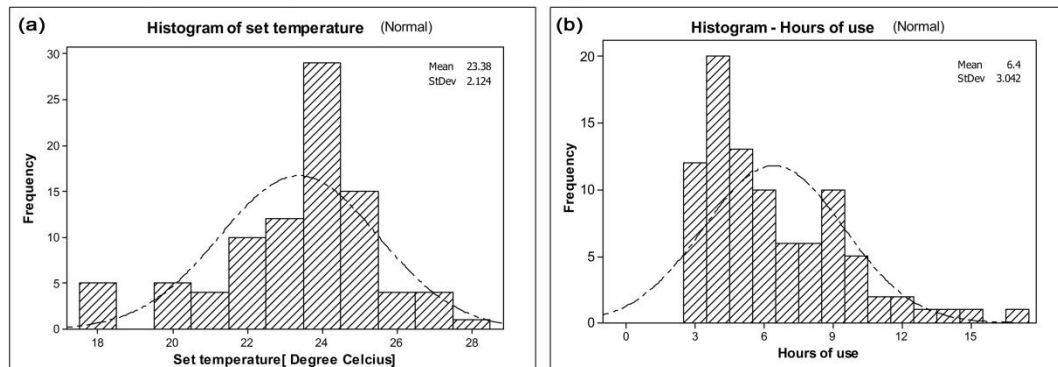

Fig 3(a). Preferred set temperature (b) Duration of air-conditioner usage

Typically, the type III units had three of the bedrooms air-conditioned. The efficiency of the system (energy efficiency ratio, EER) was found to vary among the residences as summarized in fig. 4(a). Fig. 4(b) shows the statistical summary of electricity consumption of type III apartments for a period of two years (2012 – 2013) summer (May), winter (December) and non-peak months (March, September).

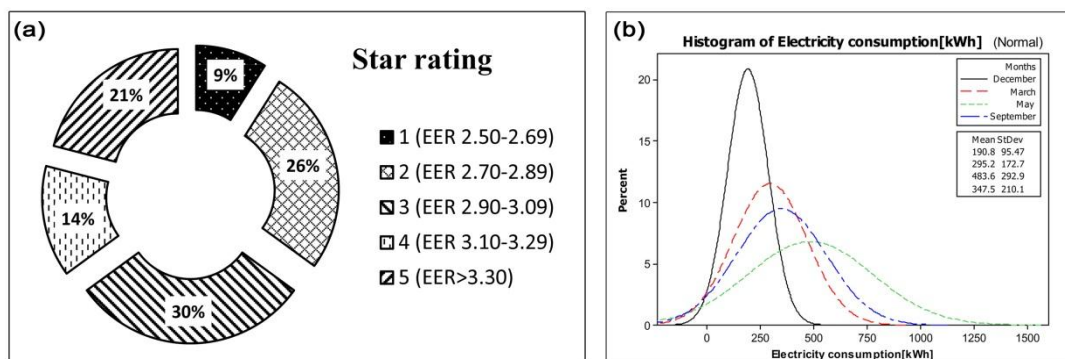

Figure 4(a). Star rating of air conditioners (b) Summary of electricity consumption in block type III

Among the 224 numbers of type III units being considered, 170 units had consistent occupancy for the two year duration being considered. The remaining units had remained partly or fully unoccupied for the duration and hence were not considered for the consumption analysis. Similarly, a normalization of the electricity consumption data was carried out to identify the outliers. Outliers in this case include a few residential units (5 nos.) which had their living rooms air-conditioned in addition to the three bedrooms. It also includes about 12 residential units for which only the lighting loads were reflected in the power consumption during summer months. This brought the sample size of the study to 153 residential units.

4 Results from real-time monitoring

4.1 Ambient micro-climate

Daily maximum outdoor dry-bulb temperature (T_{out}) varied between 38°C and 42°C during peak summer (May) and daily minimum T_{out} varied between 22°C to 25°C during winter. Fig. 5 shows the distribution of hourly temperature and RH variations during summer (May) and winter (December). The hatched boundary indicates comfort zone prescribed by the national building code, India. Average diurnal

variation of 10°C during summer and 7°C during winter was noted in the on-site measurements as shown in the figure. By virtue of its vicinity to the sea shore (4 km from Bay of Bengal) and its suburban location with very low development density, the site recorded air velocities up to 6 m/s especially in the evenings.

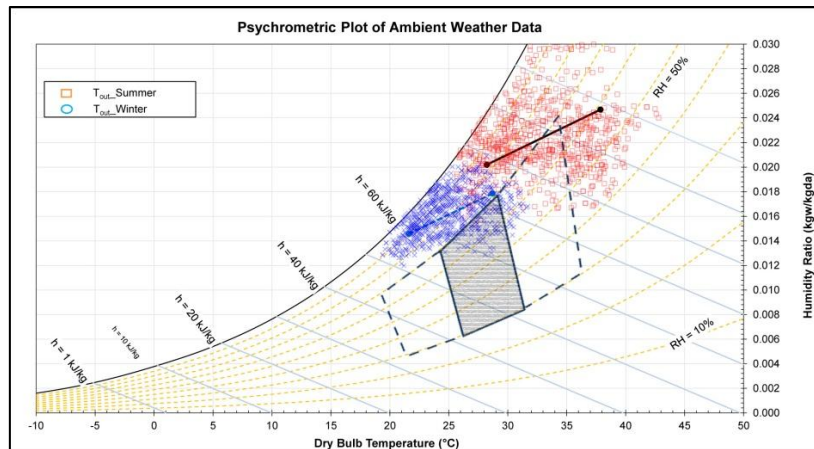

Figure 5. Psychrometric chart for summer and winter

4.2 Indoor thermal variations

Indoor thermal variations were investigated in terms of T_{in} , T_r , RH and V_a for different occupied zones and T_s and heat flux of various wall and roof surfaces. On a typical summer day, T_{in} exhibited a diurnal variation of 4 to 5°C as compared to the T_{out} variation of about 10°C. Thermal lag between T_{out} and T_{in} ranged from 1 to 2.5 hours depending on orientation, design configurations and window sizes of the zone. The trend in T_r variations followed that of T_{in} . Maximum daily V_a of up to 1.5 m/s were recorded and the average values range from 0.3 to 0.6. Fig 6(a) and (b) show the T_{in} , T_r and V_a for a west exposed room for 3 representative days in summer (May 8 to 10). East and west exposed walls experienced higher heat gains. Maximum daily heat gains varied from 15 to 20 W/m² and heat losses varied from 5 to 8 W/m².

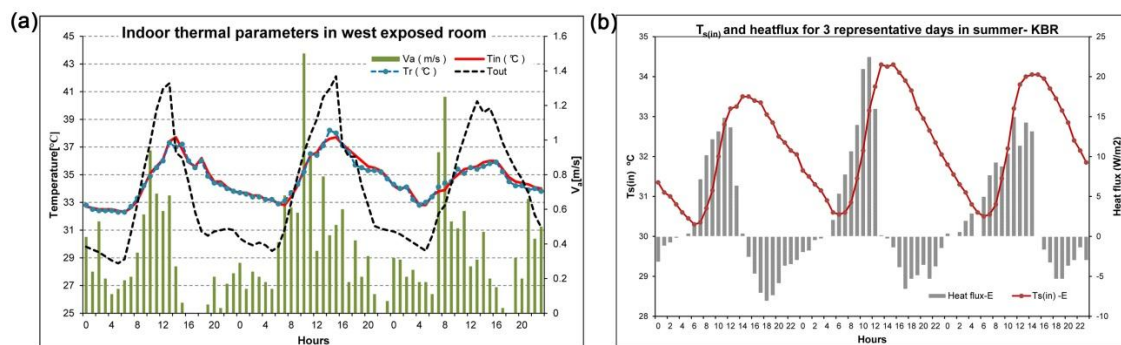

Figure 6(a). Indoor thermal variations (b) $T_{s(in)}$ and heat flux variations

4.3 Comfort estimate based on adaptive comfort criteria

Adaptive thermal comfort was evaluated in terms of the running mean temperature (T_{rm}), adapted from Nicol & Humphreys (2010). Thermo-neutrality and acceptable limits were adapted from the findings of Rajasekar & Ramachandraiah (2010) as shown in equation 1.

$$\text{Eq.1}$$

The upper and lower limits are adapted based on EN15251 recommendations for acceptability category I and II which represents ‘high expectation’ and ‘normal expectation’ respectively.

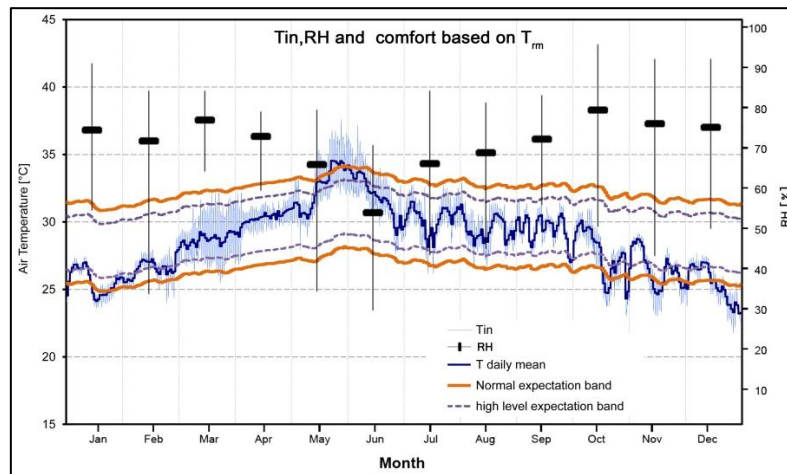

Figure 7. Comfort evaluation based on T_{rm}

Fig. 7 shows the hourly T_{in} variation and the T_{rm} acceptability limits estimated based on measured T_{out} for one year duration. Monthly summary of RH variations have also been presented. The graph corresponds to the measurements made in KBR which had an east and north exposure. Based on this analysis the frequency for which T_{in} exceeded T_n (of the corresponding day estimated based on T_{rm}) was estimated. Table 1 presents a summary for KBR and MBR.

Table 1: Frequency of thermal discomfort estimated based on T_{rm}

Months	% time T_{in} exceeds T_n (based on T_{rm})				Base Neutral Temperature	
	High expectation		Normal expectation		KBR	MBR
	KBR	MBR	KBR	MBR		
April	3%	0%	0%	0%	73%	61%
May	32%	46%	20%	26%	87%	89%
June	30%	32%	15%	17%	85%	79%
July	4%	6%	0%	0%	57%	48%

5. Simulation studies

In order to analyse the variations in comfort and corresponding cooling energy use across the gated community, a simulation model was developed in Design Builder software tool. The model was then exported to Energy Plus V8.1 for carrying out parametric simulations. The actual design configurations and envelope properties were adopted for the simulation model and the weather data was obtained from ISHRAE database (ISHRAE weather data 2012). Fig. 8 shows a screen shot of the site plan and typical floor plan model developed in Design Builder software tool. Simulations were carried out (1) for a naturally ventilated scenario for estimating the magnitude of thermal discomfort and (2) a typical intermittently cooled scenario for estimating the cooling energy demand. The air-conditioning system operation schedule and set-point temperatures for the simulations were based on the subjective survey results. A typical lower floor (1st floor) and an upper floor (13th floor) were simulated for the above mentioned conditions. The results from the simulations were

compared with the real-time samples in order to verify the consistency and the pattern of variation. The methodology adopted is shown in fig. 9.

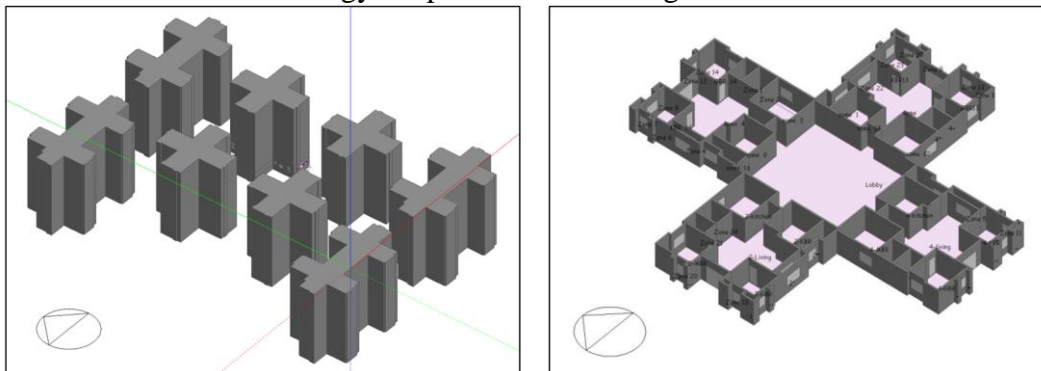

Figure 8. Design builder model of the site and a typical floor plan

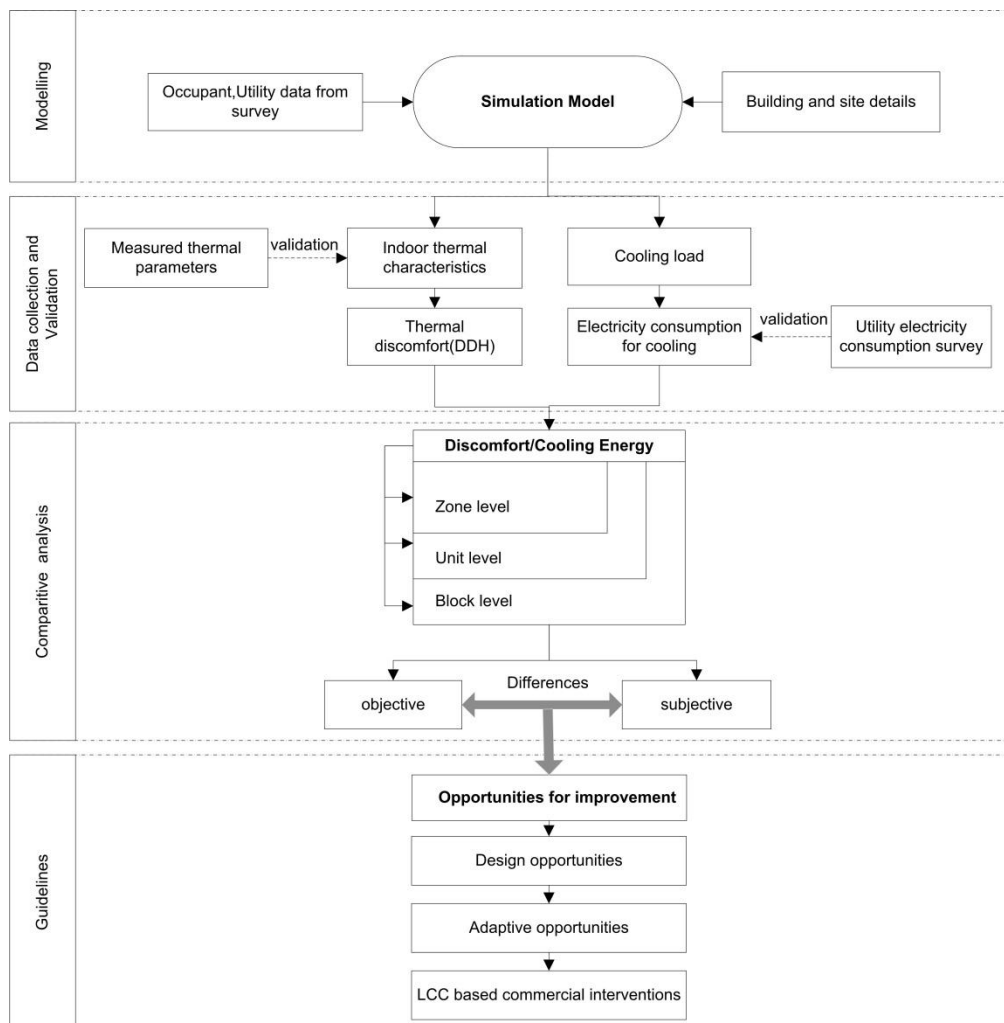
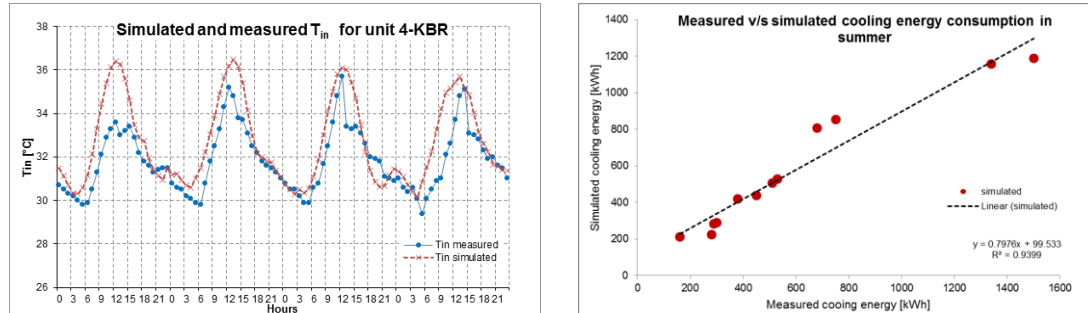

Fig. 9. Methodology adopted for the simulation analysis

5.1 Comparison of measured and simulated results

During the days when measured ambient weather conditions and simulation weather data were similar, the measured and simulated indoor thermal comfort results were found to be in good agreement. Fig. 10(a) compares one instance of measured and simulated indoor air temperature (T_{in}) during peak summer (May 7 to 10). During this period only a marginal variation existed between actual and simulated ambient weather conditions. Similar results were obtained in the corresponding PMV

variations between measured and simulated instances. For the purpose of consistency and to leave scope for further studies beyond the context of this article, the results for further discussions have been based on the ISHRAE weather data. A comparison of the simulated and actual power consumption was made in which the actual number and type of air conditioners, set temperatures and operation pattern for a few



residences from the subjective survey data were simulated. The pattern of power consumption was similar in the simulated and actual scenario as indicated in fig. 10(b).

Figure 10. Comparison of measured and simulated values (a) T_{in} (b) cooling energy consumption

Based on the findings presented in figs. 3 and 4, the simulations were carried out considering a cooling set point temperature of 23.5°C and operational duration of 6.5 hours per day. An energy efficiency ratio (EER) of 3.0 W/W was considered for the cooling system.

6 Results and Discussion

Severity of thermal discomfort was calculated in terms of degree discomfort hours (DDH) given by

$$\sum ($$

and expressed in degree hours. In the residential setting concerning the present study, the cooling energy consumption was primarily from the night-time conditioning. Considering this fact, DDH is calculated for the duration 09:00 PM to 6:00 AM.

6.1 Inter-zonal variations in discomfort and cooling energy demand

This section presents the variations in DDH and cooling energy demand among the conditioned zones within a residential unit. Fig. 11(a) presents a binned correlation of daily T_{out} maxima and the corresponding night time DDH for the three bedrooms of unit 4 in block A. KBR is exposed to east and north, GBR to north and west and MBR to west orientation. The data pertains to summer (March – July) where heat discomfort and comfort cooling were predominant. Night time DDH exhibited a strong and linear correlation with the ambient daily T_{out} average irrespective of design configurations. Thermal discomfort in MBR was higher than the other two zones. Though the difference is marginal in the trend lines, the magnitude and frequency indicated by the bin sizes are different from each other. Corresponding variation in the cooling energy consumption is shown in fig. 11(b). In order to account for the floor area variations among the zones, the area averaged cooling energy consumption (measured in kWh/m²) has been considered. In conjunction with the DDH variations, cooling energy consumption in MBR was found to be considerably higher than that of KBR. Similar variations were also noted in other residential units.

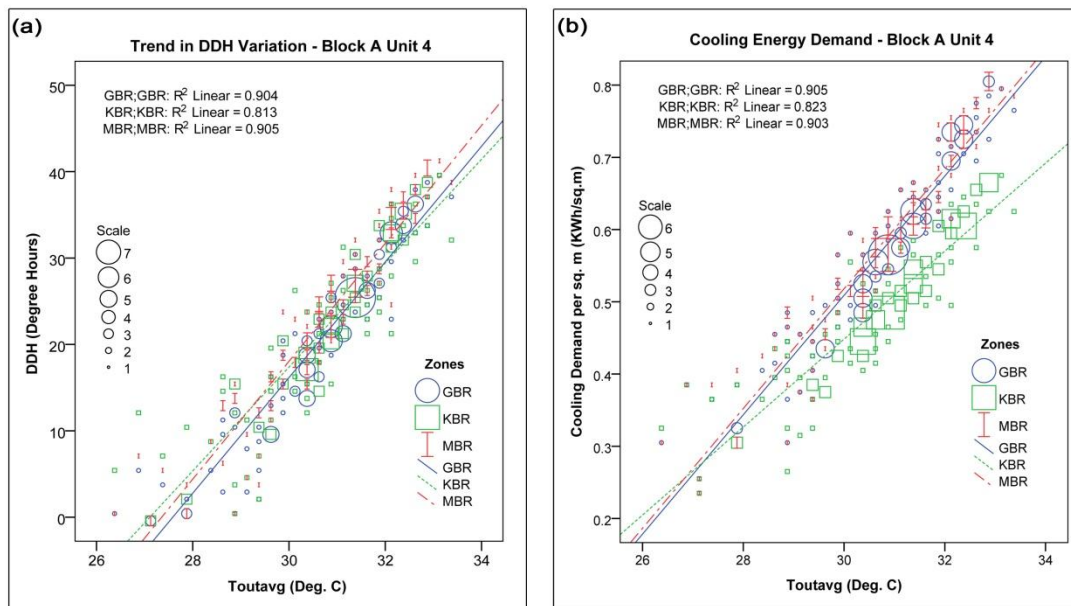

Figure 11(a). Trend in DDH variation (b) Trend in cooling energy consumption

6.2 Variations between units

The floor area and design configuration are identical across the residential units of type III apartment block. However these units vary from each other in terms of orientation and solar exposure due to which the DDH and corresponding cooling energy consumption were found to vary from one another. To analyse the differences in thermal discomfort variations across residential units, DDH and the corresponding cooling energy consumption for the three bedrooms were averaged for each unit. Table 2 shows the cross correlation results of DDH for 8 residential units, 4 each in apartment block A and B.

Table 2: Inter-Item Correlation Matrix of DDH in Block A and B

	A 1	A 2	A 3	A 4	B 1	B 2	B 3	B 4
A 1	1.00	0.59	0.32	0.67	0.99	0.55	0.35	0.64
A 2	0.59	1.00	0.54	0.99	0.59	0.99	0.53	0.99
A 3	0.32	0.54	1.00	0.48	0.35	0.65	0.99	0.52
A 4	0.69	0.99	0.49	1.00	0.69	0.96	0.49	0.99
B 1	0.99	0.59	0.35	0.69	1.00	0.56	0.39	0.64
B 2	0.55	0.98	0.65	0.96	0.56	1.00	0.64	0.98
B 3	0.35	0.53	0.99	0.49	0.39	0.64	1.00	0.53

Thermal discomfort was more uniform for residential units with similar solar exposure conditions. For instance, the strength of correlation between A1-B1, A2-B2, A3-B3 and A4-B4 were relatively stronger when compared to the strength of correlation within units of block A and B. A similar trend in variation was observed in terms of cooling energy. Fig. 12 shows the cooling energy demand variations in the four residential units of block A. Unit 4 with the longer axis exposed to east and west orientations experienced higher cooling energy demand compared to other units. Similarly, Unit 1 with its longer axis exposed to north and south experienced a lower cooling energy demand compared to the other units.

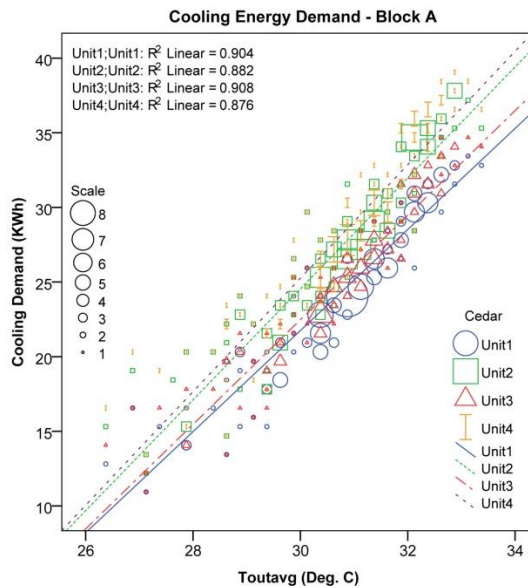

Figure 12. Trend in cooling energy demand for Block A

The significance of variation among residential units located at the same floor level of a given block was tested through a one-way between subjects ANOVA test. The daily total cooling energy demands for the four units located in the upper floor level (level 13) of block A, obtained through simulations were considered for the analysis. There was a significant difference among the sample means of the four units at $p < 0.05$ level ($F_{3,480} = 26.8$, $p = 0$). Post hoc comparison using the Tukey HSD test indicated that the mean score for units with longer axis exposed to similar orientations were not significantly different from each other. For instance, the mean cooling energy demand for unit 1 ($\mu = 24.2$, $\sigma = 4.8$) was not significantly different from unit 3 ($\mu = 24.6$, $\sigma = 4.9$). On the other hand, the cooling energy demand for units with varying longer axis orientations were significantly different, such as unit 2 ($\mu = 28.4$, $\sigma = 5.7$) and unit 3 ($\mu = 24.6$, $\sigma = 4.9$).

6.3 Variation between blocks

By virtue of the site planning and the solar altitude and azimuthal angles the apartment blocks were found to mutually shade each other. This phenomenon resulted in dissimilarity in the insolation levels of walls between lower and upper floor levels of the apartment blocks (fig. 13a). The result has been obtained from mutual shading and insolation analysis carried out using Autodesk Ecotect software tool. Fig. 13 (b) shows the annual shadow pattern cast by the apartment blocks in which the extent of mutual shading can be visualized.

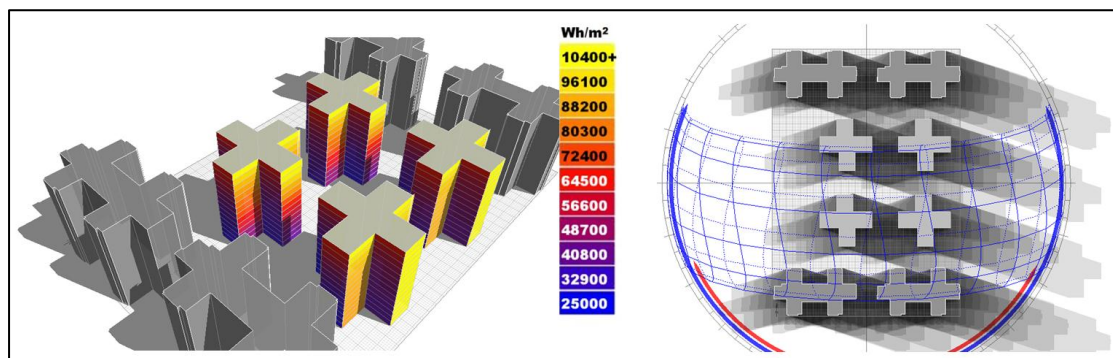

Figure 13(a). Insolation on wall surfaces - summer (b) Annual shadow pattern

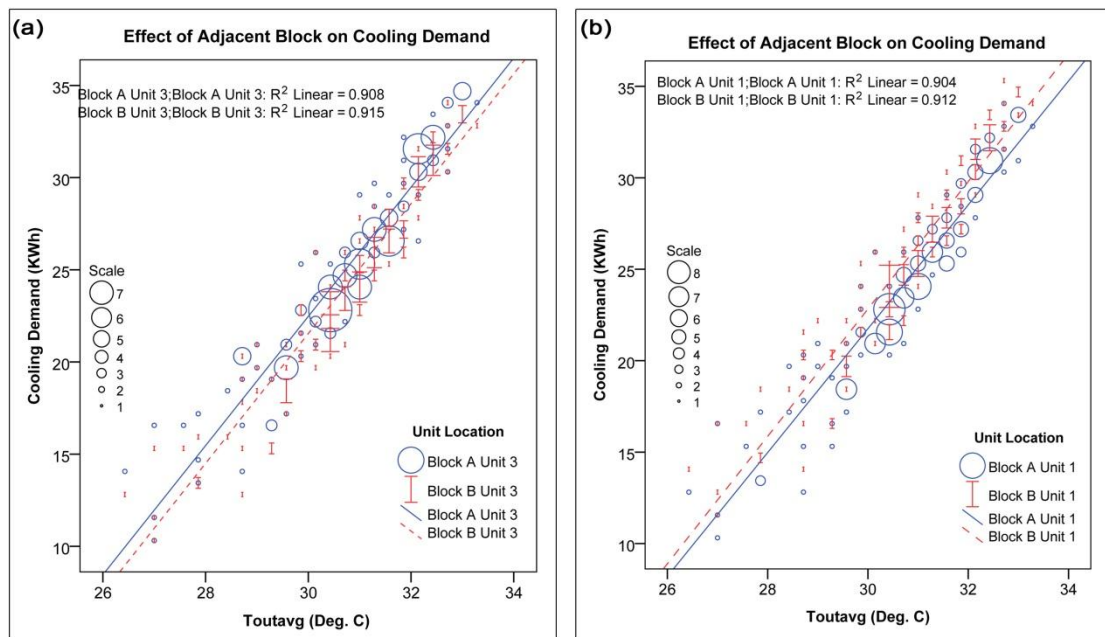

Figure 14(a). Cooling energy demand -Unit 3 (b) Cooling energy demand -Unit 1

Fig. 14 (a) and (b) compares the variation in cooling energy consumption for units 1 and 3 from block A and B located in the lower floor level. The cooling energy demand of unit 3 in block A was found to be marginally higher than that of unit 3 in block B, which is shaded by the adjacent block. Similarly, cooling energy demand of unit 1 in block B was found to be marginally higher than that of unit 1 in block A.

The effect of mutual shading of adjacent blocks on the cooling energy demand was tested through a two-way ANOVA test. The simulated daily total cooling energy demands of these four units at lower and upper floor levels were compared. At the lower floor level, there was a significant difference among population means of the above cases at $p < 0.05$ level ($F_{3,480} = 31.4$, $p = 0$). Post hoc comparison using the Tukey HSD test indicated that the mean score for unit 3 in block A ($\mu = 25$, $\sigma = 5.4$) was significantly different than that of unit 3 in block B ($\mu = 28.9$, $\sigma = 6.4$). Similarly the mean score for unit 1 in block A ($\mu = 24.2$, $\sigma = 5.2$) was found to be significantly different than that of unit 1 in block B ($\mu = 30.4$, $\sigma = 6.4$). At the upper floor level, there was no significant difference among population means of the above cases.

6.4 Floor level variations in discomfort and cooling energy demand

Fig. 15 compares the average cooling energy demand for residential units located in the lower and upper floor level. The average demand in the upper floor level was found to be marginally higher than the lower floor level.

A one-way between subjects ANOVA was conducted to compare the effect of floor height variation on cooling energy demand in residential units located at lower and upper floor levels. The daily average cooling energy demands for the four units were considered for the analysis. There was a significant effect of floor height on the cooling energy demand at $p < 0.05$ level for the two cases ($F_{1,960} = 55.5$, $p = 0$). Post hoc comparison using the Tukey HSD test indicated that the mean score for the cooling energy demand in the lower floor level ($\mu = 26.7$, $\sigma = 5.8$) was significantly different from that on the upper floor ($\mu = 28.9$, $\sigma = 7.0$).

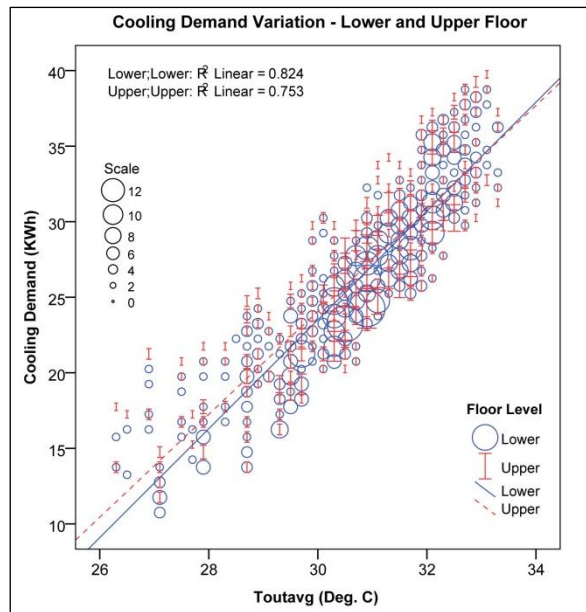

Figure 15. Cooling demand variations – lower and upper floor levels

6.5 Comparison of simulated and actual energy consumption trends

Fig. 16(a) shows the overall trend in cooling energy consumption across the residential units as obtained from the simulation studies. Maximum cooling energy is consumed by unit 4 followed by unit 2 in all the four blocks. The residential unit which consumes minimum cooling energy was found to vary among blocks. The units facing the core (shaded by the adjacent block in east or west) exhibit lesser consumption compared to those facing the periphery.

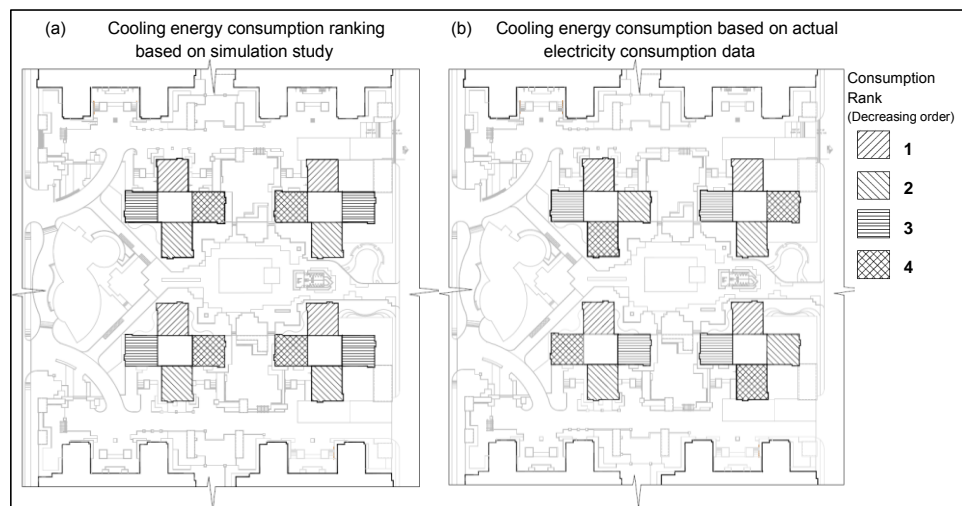

Figure 16. Energy consumption pattern (a) simulation studies (b) Actual consumption data

Fig. 16(b) shows the pattern of power consumption obtained from the actual utility electricity consumption data. Unit 4 in all the four blocks was found to consume higher energy compared to the other units. The pattern of consumption was found to be non-uniform in the other orientations. The role of user preferences towards thermal comfort and life style on the pattern of actual energy consumption was clearly noticeable from the above results. This was found to overshadow the effect of climatic factors and design configurations in some of the instances. It must be noted that, though adaptive opportunities can be integrated in the built form, various

concerns arise in such gated communities on their effective utilization. For instance, as shown in fig. 14, the mutual shading of blocks resulted in consumption variation which was not noticeable in the actual scenario. This can be attributed to factors including concerns of visual privacy apart from variations in comfort perception and living patterns.

7 Opportunities for comfort and energy efficiency in gated communities

The non-uniformity in thermal discomfort and consequent variations in energy bills that the residents would pay for the rest of their occupancy tenure stimulates the following opportunities.

7.1 Design opportunities

This involves customized design improvements from the comfort and energy point of view at the residential unit level so as to maintain uniformity among units. Several findings on influence of design factors on comfort improvements have been reported earlier. Significant studies include those of Givoni (1994) who has discussed the effects of building design features such as the layout, window orientation, shading and ventilation, on the indoor environment and energy use. Suresh et al (2011) have presented a comprehensive review of building envelope components and related energy savings.

7.2 Adaptive opportunities and occupant inclination

Occupants can be educated regarding the adaptive opportunities provided in the design and related benefits in terms of comfort and energy expenses which could act as stimuli for enhancing adaptive mechanism. Becker et al (1981) reported the influence of attitudinal factors influencing residential energy use. Wilson & Dowlatabadi (2007) discussed the influence of conventional and behavioural economics, technology adoption theory and attitude-based decision making, social and environmental psychology, and sociology on the decision making with specific application to residential energy use. Occupant adaptation and scope for comfort improvements have been reported in detail by Zain et al (2007), Ren et al (2011) and Deuble & de Dear (2014). Studies conducted for a similar residential type in a hot-dry climate (Rajasekar et al 2014) showed that adaptive occupancy patterns could effect a significant improvement in indoor thermal comfort.

In order to quantify the design and adaptive opportunities, a prototype matrix was developed which evaluates the inter-zonal thermal severity within a unit as well as across units based on the predicted comfort and the usage pattern of the residents. The methodology for evaluating the discomfort severity involved the following steps

- Step 1. Cooling energy consumption per unit floor area of conditioned zones were obtained through simulations
- Step 2. A baseline criteria zone which consumes minimum cooling energy among the zones was selected
- Step 3. Energy consumption of the other zones were factored using this baseline and a relative consumption was obtained
- Step 4. A usage factor which depicts the magnitude to which the zone is utilized was defined. This was assigned based on the proposed activity in the space
- Step 5. Based on the relative consumption discussed in step 3 and the usage factor, magnitude of severity was estimated. This indicates the magnitude of thermal discomfort and related cooling energy consumption.

Step 6. Whole-house severity was estimated by averaging the zone wise severity of a given residential unit

Step 7. Depending on the magnitude of whole-house severity, a ranking was assigned for different units under consideration

Table 3: Thermal severity ranking matrix

	Unit 1			Unit 2			Unit 3			Unit 4		
	Z1	Z2	Z3	Z1	Z2	Z3	Z1	Z2	Z3	Z1	Z2	Z3
Relative consumption	-0.50	0.00	-0.80	-0.63	-0.39	-0.60	-0.23	-0.22	-0.91	-0.71	-0.37	-0.68
Zoning order**	1	2	3	1	2	3	1	2	3	1	2	3
Conditioning	Y	Y	Y	Y	Y	Y	Y	Y	Y	Y	Y	Y
Relative Severity	-0.50	0.00	-0.40	-0.63	-0.31	-0.30	-0.23	-0.18	-0.45	-0.71	-0.29	-0.34
Whole-house Severity	-0.45			-0.41			-0.29			-0.45		
Whole-house Ranking	3			2			1			3		

** 1 – Master Bedroom (factored as 1); 2 – Kid’s Bedroom (factored as 0.8);
3 – Guest Bedroom (factored as 0.5)

Table 3 presents the matrix which analyses the three bedrooms across four residential units of block A. For the purpose of analysis flexibility, the three rooms have been referred as zones 1, 2 and 3 respectively (Z1, Z2 and Z3). For these zones, cooling energy per unit floor area was obtained through the simulations. Among the 12 zones being considered, Z2 in unit 1 was found to consume lesser cooling energy and was considered as a base line. Consumptions of the other zones were factored with this base line and the relative consumption is presented in row 3. Higher the negative number, higher is the energy consumption compared to the base line. The usage factor discussed in step 4 is listed in row 4 and is denoted as zoning order. This has been defined as per existing zoning configuration and all the zones are assumed to be conditioned in this case.

As per the subjective study results during summer MBR remains occupied and conditioned for a maximum duration followed by KBR and GBR. In view of this MBR was factored with 1.0, KBR with 0.8 and GBR with 0.5. These factors can be varied depending on contextual variations. Relative severity was obtained by factoring the relative consumption with the zoning order (row 6). For instance, zone 3 in unit 3 which had the highest energy consumption (-0.91) has been scaled down since it has been zoned as guest bedroom in the existing design and was expected to be used only intermittently. This step (step 5) opens up venues for designers to reconfigure the zoning based on the inherent thermal severity and usage requirements. In addition it provides stimuli for the residents to look towards modifications in living patterns for improved comfort and energy efficiency. Whole-house thermal severity and rank ordering were estimated based on step 6 and 7. This method provides a commercial perspective for comfort and energy efficiency in such modular building types and would bring more transparency on the cost of thermal comfort.

7.3 Cost interventions and challenges in implementation

A life cycle cost (LCC) assessment can be provided to the customer on cost interventions for comfort improvements and energy efficiency which would draw an

additional premium. These interventions can vary from improving the air-conditioning system efficiency to building envelope thermal property improvements. A study by Viginie & Michael (2007) shows that by improving the EER of the air-conditioning system from 2.34 to 2.81 an improvement of 17% in terms of energy consumption is observed based on LCC analysis. Similarly an LCC based study on influence of building thermal insulation on cooling load in the hot and humid climates (Aktacir et al, 2010) shows that with improvement to the wall insulation a saving of 17-20% can be obtained. Studies by Banfi et al (2008) in Swiss residential buildings showed that the benefits of the energy-saving attributes are significantly valued by the consumers and strongly influenced their willingness to pay for energy-saving measures. Investigations by Nair et al (2010) have shown that personal attributes such as income, education, age and contextual factors, including age of the house, thermal discomfort, past investment, and perceived energy cost, preference for a particular type of energy efficiency measure influenced the energy efficiency investments in existing residential buildings.

Though this is a promising approach towards energy efficiency, the inherent inter-residence dissimilarity in comfort and energy use in this building typology described in section 6.3 and 6.4 poses the challenge of setting benchmarks. This is primarily due to the fact that part of the residential units will require high cost interventions, while part of them might naturally meet the benchmarks. In this case it would be required to quantify the economic interventions for individual residential units. Since these condominiums are multi-tenant occupancy based models, the commercial implications and saleability issues would be equally challenging. A typical example in the context of the present study is discussed further.

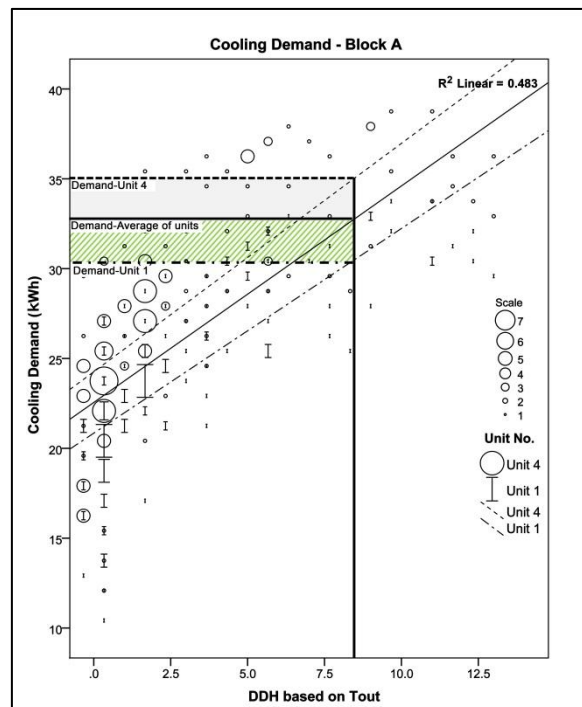

Figure 18. Cooling energy demand – Block A

Fig. 18 presents the relation between ambient DDH (based on T_{out}) for conditioned hours and cooling energy demand for residential units 1 and 4 in condominium block A. The average cooling energy demand for block A is shown through the solid trend

line, while the dotted trend lines represent those of unit 1 and 4. For the purpose of setting an upper limit for cooling energy consumption, the T_{rm} for summer months (March to July) were statistically analysed and the 90 percentile value (32°C) was obtained. From this, the corresponding T_n was estimated (30.6°C) using eq. 1. The DDH cut-off for a T_n of 29.1°C was estimated to be 8.9 degree hours. From fig. 17 it can be found that the cooling energy demand for this DDH cut-off corresponds to 32.5 KWh/day with respect to block A average. Notably, the corresponding cooling energy demands for unit 4 stands at 35 KWh while that of unit 1 stands at 30.1 KWh. This amounts to about 14% variation in cooling energy demand between the two adjacent residential units with a similar design and built-up area. In order to be more representative, this quantitative difference needs to be considered in the LCC analysis for comfort and energy efficiency interventions either in terms of HVAC system efficiency or envelope thermal property improvements.

8 Conclusions

Thermal comfort and related energy consumption scenario in condominium style residential buildings were presented in the study. Analysis was focused on residential units distributed among four identical blocks. Subjective surveys administered with the residents on the air conditioner usage pattern revealed that the set point temperatures and operation duration were highly non-uniform in nature. Statistical mean value of 23.5°C in terms of set point temperature and 6.5 hours of air conditioner usage per day were obtained from the study. Under naturally ventilated conditions, the indoor diurnal variations ranged between 4 to 5°C as compared to the T_{out} variation of about 10°C . Thermal lag between T_{out} and T_{in} ranged from 1 to 2.5 hours. Maximum daily heat gains varied from 15 to 20 W/m^2 and heat losses varied from 5 to 8 W/m^2 . Heat discomfort was prevalent during summer (ePMV +1.5 to +2.8) and thermal comfort/neutrality was prevalent during winter (ePMV -0.5 to +0.8). A greater extent of indoor temperatures was found to be outside the acceptability criteria of adaptive comfort in terms of T_{rm} , during peak summer (May and early June).

The measured indoor thermal comfort and associated energy consumption were found to be in good agreement with the simulated results. Thermal discomfort severity was estimated in terms of night time DDH which was found to exhibit a strong and linear correlation with the ambient daily T_{out} maxima irrespective of the design configurations. Though T_{in} maxima and minima in various zones of a residential unit exhibited similarity, the magnitude and frequency of DDH were found to considerably differ from each other. These variations were also noticeable in the cooling energy variations of various zones. Thermal discomfort was more uniform for residential units with similar solar exposure conditions. Mutual shading by adjacent blocks was found to have a significant effect on both the discomfort and cooling energy estimates. Residential units located at the higher floor levels were found to have marginally higher cooling energy demand compared to those in the lower floor level. The trend in simulated and actual energy consumption pattern was comparable only among the flats exposed to critical orientations. The pattern of consumption was found to be non-uniform in the other orientations.

Viability of interventions at the design stages and post occupancy stages for improvement in thermal comfort and reduction in cooling energy were also explored. A prototype matrix was presented for evaluation of thermal severity considering both the predicted comfort as well as the usage pattern of the residents. The method of

ranking various zones in a given residential unit as well as a comparative evaluation of various residences forms a useful tool for both the residents as well as the designers to take a relook at the commercial value of thermal comfort and cooling energy in this building type. For the commercial interventions on energy efficiency to be more representative, the inherent comfort variations among residential units needs to be considered in the LCC analysis.

9 Scope for further studies

The findings of the study throws light on the inbuilt non-uniformities in thermal comfort and energy consumption in condominium type residential developments. Detailed studies involving residential unit level power consumption measurements and user behavioural pattern is essential for evolving more conclusive outcomes. Further studies on limitations to adaptation in such residential type needs to be explored so that a judicious estimate of adaptation can be arrived. Studies relating to life cycle cost estimates on thermal comfort improvements and its commercial viability in the market needs to be explored to ensure effective implementation.

Acknowledgements

We wish to acknowledge the inputs form Ms. Anupama Udaykumar and the support extended by the facility management team and residents of the gated community.

References

1. Becker, Lawrence J., Seligman, C., Fazio, Russell H., Darley, John Mcconnon, 1981. Relating Attitudes to Residential Energy Use. *Environment and Behavior*, 13(5), pp 590-609.
2. Brager, G.S., & De Dear, R.J., 1998. Thermal adaptation in the built environment: a literature review. *Energy and Buildings*, 17, pp 83-96.
3. Brager, G.S., & De Dear, R.J., 2001. Climate, Comfort & Natural Ventilation: A new adaptive comfort standard for ASHRAE Standard 55. *Proceedings, Moving Thermal Comfort Standards into the 21st Century*, Windsor, UK, April 2001.
4. Cheng, V., Ng, E. & Givoni, B., 2004. Effect of envelope colour and thermal mass on indoor temperatures in hot humid climate. *Solar Energy*, 78, pp 528–534.
5. Deuble, Max Paul & de Dear, R.J., 2014. Is it hot in here or is it just me? Validating the post-occupancy evaluation. *Intelligent Buildings International*, DOI:10.1080/17508975.2014.883299.
6. Gireesh, Nair; Leif, Gustavsson; Krushna, Mahapatra, 2010. Factors influencing energy efficiency investments in existing Swedish residential buildings. *Energy Policy*, 38(6), June 2010, pp 2956-2963.
7. Givoni, B., 1994. Building design principles for hot humid regions. *Renewable Energy*, 5, pp 906-916.
8. Guerra Santin, Olivia; Laure, Itard & Henk, Visscher, 2009. The effect of occupancy and building characteristics on energy use for space and water heating in Dutch residential stock. *Energy and Buildings*, 41, pp 1223–1232.
9. Humphreys, M.A., 1981. The dependence of comfortable temperatures upon indoor air and outdoor climate, In: K. Ccna and J.A. Clark (Eds.), *Bioengineering, Thermal Physiology and Comfort*, Elsevier, Amsterdam.
10. Humphreys, M.A., & Nicol, J.F., 1998. Understanding the Adaptive Approach to Thermal Comfort. *ASHRAE Transactions*, 104 (1), pp 991-1004.
11. Indraganti, M., 2010. Thermal comfort in naturally ventilated apartments in summer: Findings from a field study in Hyderabad, India. *Applied Energy*, 87 (3), pp. 866 – 883.

12. ISHRAE weather data, 2012, Available from
<http://apps1.eere.energy.gov/buildings/energyplus/weatherdata_sources.cfm>.
(1 June, 2012)
13. Joana M. Abreu., Francisco Camara, Pereira, & Paulo, Ferrao, 2012. Using pattern recognition to identify habitual behavior in residential electricity consumption. *Energy and Buildings*, 49, pp 479-487.
14. Khaled, el-deeb, Abbas, el-zafarany, & Ahmed, sherif, 2012. Effect of Building Form and Urban Pattern On Energy Consumption of Residential Buildings in Different Desert Climates. *PLEA 2012 - 28th Conference, Opportunities, Limits & Needs Towards an environmentally responsible architecture*, Lima Peru, 7-9 November 2012.
15. Kruger, E. & Givoni, B., 2004. Predicting thermal performance in occupied dwellings. *Energy and Buildings*, 36, pp 301-307.
16. Kruger, E. & Givoni, B., 2008. Thermal monitoring and indoor temperature predictions in a passive solar building in an arid environment. *Building and Environment*, 43, pp. 1792-1804.
17. Kruger, E. & Givoni, B., 2011. Simplified method for yearlong thermal analysis of building prototypes. *Renewable Energy*, 36, pp 699-708.
18. Letschert, V., & McNeil, M., 2007. Coping with residential electricity demand in india's future –How much can efficiency achieve?, *ECEEE 2007 Summer study proceedings-saving energy, Just do it!*, La Colle sur Loup, France, 4-9 June 2007.
19. Morrissey J. & Horne, R.E., 2011. Life cycle cost implications of energy efficiency measures in new residential buildings. *Energy and Buildings*, 43(4), pp 915-924.
20. Nicol, J. F., 2004. Adaptive thermal comfort standards in the hot–humid tropics. *Energy and Buildings*, 36(7), pp 628-637.
21. Nicol, J.F., & Humphreys, M.A., 2010. Derivation of the equations for comfort in free-running buildings in CEN Standard EN15251, Special Issue Section: International Symposium on the Interaction Human and Building Environment, *Buildings and Environment*, 45(1) , pp 11-17.
22. Rajasekar, E., & Ramachandraiah, A., 2010. Adaptive comfort and thermal expectations – a subjective evaluation in hot humid climate, *Proceedings of conference: Adapting to change: New thinking on comfort*; Cumberland Lodge, Windsor, UK, 9 – 11 April 2010.
23. Rajasekar, E., Anupama, Udaykumar & Venkateswaran, Rajan , 2014. Thermal comfort beyond building design – An investigation in naturally ventilated residential apartments in a hot-dry climate. *Advances in Building Energy Research*, DOI:10.1080/17512549.2013.865553.
24. Shastry, Vivek; Mani, Mani & Tenorio, Rosangela., 2012. Impacts of Modern Transitions on Thermal Comfort in Vernacular Dwellings in Warm-Humid Climate of Sugganahalli (India). *Indoor Built Environment*, DOI: 10.1177/1420326X12461801.
25. Silvia, Banfi; Mehdi, Farsi; Massimo, Filippini & Martin, Jakob, 2008. Willingness to pay for energy-saving measures in residential buildings. *Energy Economics*, 30(2), pp 503-516.
26. Suresh B., Srikanth, M. & Robert F., 2011. Passive building energy savings: A review of building envelope components. *Renewable and Sustainable Energy Reviews*, 15(8), pp 3617-3631.

27. Udaykumar, Anupama; Rajasekar, E. & Venkateswaran, Rajan, 2013. Thermal comfort characteristics in naturally ventilated, residential apartments in a hot-dry climate of India. *Indoor Built Environment*; DOI: 10.1177/1420326X13504120.
28. Wilson, C. & Hadi, D., 2007. Models of Decision Making and Residential Energy Use, *Annual Review of Environment and Resources*, 32(2), pp. 1-35.
29. Zhengen, Ren; Zhengdong, Chen & Xiaoming, Wang, 2011. Climate change adaptation pathways for Australian residential buildings. *Building and Environment*, 46(11), pp 2398-2412.

Appendix – A

Energy consumption : Data Sheet

1. Building Name : _____

2. Flat no : _____

3. No of occupants : _____

4. No of air conditioners : _____

5. Air conditioner: 1 Location of AC: _____

(a) Capacity: Tons

(c) Energy star rating : Nil 1 2 3 4 5

(d) Set temperature: °C

(e) Months of operation :

1	2	3	4	5	6	7	8	9	10	11	12
---	---	---	---	---	---	---	---	---	----	----	----

Hours of Operation: Peak

1	2	3	4	5	6	7	8	9	10	11	12	1	2	3	4	5	6	7	8	9	10	11	12
---	---	---	---	---	---	---	---	---	----	----	----	---	---	---	---	---	---	---	---	---	----	----	----

Non-Peak

1	2	3	4	5	6	7	8	9	10	11	12	1	2	3	4	5	6	7	8	9	10	11	12
---	---	---	---	---	---	---	---	---	----	----	----	---	---	---	---	---	---	---	---	---	----	----	----

6. Air conditioner: 2 Location of AC: _____

(a) Capacity: Tons

(c) Energy star rating : Nil 1 2 3 4 5

(d) Set temperature: °C

(e) Months of operation :

1	2	3	4	5	6	7	8	9	10	11	12
---	---	---	---	---	---	---	---	---	----	----	----

Hours of Operation: Peak

1	2	3	4	5	6	7	8	9	10	11	12	1	2	3	4	5	6	7	8	9	10	11	12
---	---	---	---	---	---	---	---	---	----	----	----	---	---	---	---	---	---	---	---	---	----	----	----

Non-Peak

1	2	3	4	5	6	7	8	9	10	11	12	1	2	3	4	5	6	7	8	9	10	11	12
---	---	---	---	---	---	---	---	---	----	----	----	---	---	---	---	---	---	---	---	---	----	----	----

7. Air conditioner: 3 Location of AC: _____

(a) Capacity: Tons

(c) Energy star rating : Nil 1 2 3 4 5

(d) Set temperature: °C

(e) Months of operation :

1	2	3	4	5	6	7	8	9	10	11	12
---	---	---	---	---	---	---	---	---	----	----	----

Hours of Operation: Peak

1	2	3	4	5	6	7	8	9	10	11	12	1	2	3	4	5	6	7	8	9	10	11	12
---	---	---	---	---	---	---	---	---	----	----	----	---	---	---	---	---	---	---	---	---	----	----	----

Non-Peak

1	2	3	4	5	6	7	8	9	10	11	12	1	2	3	4	5	6	7	8	9	10	11	12
---	---	---	---	---	---	---	---	---	----	----	----	---	---	---	---	---	---	---	---	---	----	----	----

8. Other electrical equipments

Sl No.	Equipments	No. of Equipments	Capacity/ Type	Star Rating	Remarks
1	Refrigerator				
2	Washing Machine				
3	Oven				
4	Induction Stove				
5	Television				
6	Other equipments				

The Greek Housing Stock and the Role of the Occupant's Behaviour in Achieving Energy Efficiency

Konstantinos Palantzidis and Dr Luisa Brotas

Low Energy Architecture Research Unit, Sir John Cass Faculty of Art, Architecture and Design, London Metropolitan University, UK,
kpalantzidis@hotmail.com; l.brotas@londonmet.ac.uk

Abstract

The present paper aims to explore the current energy performance of the existing housing stock of Greece while also examining the energy performance of buildings that have undergone refurbishment since the passing of the Energy Performance of Buildings Directive in 2010. A literature review of energy performance legislation and previous surveys are compared to data obtained from 400 dwellings with Energy Performance Certificates for the Thessaloniki and Naousa cities. A total of thirteen case studies of dwellings that underwent energy upgrade refurbishments were further examined (energy and cost) to draw conclusions in respect of their improvement. In order to further investigate how the energy upgrades affected the thermal comfort of the occupants, the thermal monitoring of three of the aforementioned dwellings were performed during the summer 2013. The owners of the above-monitored dwellings were also given questionnaires which investigated their level of satisfaction with the result of the upgrades. Lastly an occupancy survey of inhabitants of the city of Naousa provides an overview of the energy status of the stock as well as the cost aspect of the upgrades. The answers from the survey also give an insight in the actions and the behaviour of the users within the environment of their homes.

Keywords: Energy Performance, POE, monitoring, adaptive behaviour

1 Introduction

The last century has seen a grown use of electrical appliances and electromechanical heating and cooling systems to climatise buildings. This has agravated the cost and energy supply, contributed to the depletion of fossil fuels and has had heavy environmental impacts (ozone layer depletion, global warming, climate change etc.). According to the International Energy Agency from 1984 to 2004 the world primary energy has grown by 49% and CO₂ emissions by 43%, with an average annual increase of 2% and 1.8% respectively.

The building sector has been found to account for more than 40% of the final energy consumption. European countries have been obliged to adopt stricter regulations in the building industry, in accordance to European Union (EU) directives, to improve building energy efficiency, to minimise energy consumption, adopt renewable energy and therefore reducing CO₂ emissions whilst promoting energy security, technological developments and employment (EPBD, 2002; EPBDrecast 2010). This is one of the mechanisms in place to prevent the depletion of fossil fuel resources and combat climate change in line with commitments of the Kyoto protocol. New buildings are required be low energy and increasingly adapt to energy from renewable sources. Strategies include improvement of the envelope performance and reduction of infiltration rates to minimise heat losses in winter and

gains in summer (also including shading of windows) as well as more energy efficient systems and as much as possible adopting renewable energy.

However, a significant proportion of the buildings in use have been built before these requirements. Steps towards improving the existing stock are imperative. These have been taken in many European countries including Greece. Programs funded in part by the European Union and in part by the local governments, providing house owners with financial incentives in order to perform upgrades to their properties, have appeared in many countries including The Green Deal in the UK, the ENEA in Italy, and the Geotcasa, Solcasa and Biomcasa schemes in Spain (EPBD-CA, 2013). There is not a comprehensive evaluation of the impact of these schemes and their overall success. Reduction in consumption has been achieved, however the targets set by the countries so far have been deemed to be modest and lacking in ambition (GMECC, 2009; BPIE, 2011).

As of 2001, the total number of dwellings in Greece, was approximately 4 million and accounted for almost 75% of the total building stock. 74.6% of the dwelling stock was built prior to 1979 (see Figure 1) and had therefore no envelope insulation. Even those built after 1979 and especially the ones during the decade after the introduction of the Hellenic Building Thermal Insulation Regulation (HBTIR), cannot be deemed much better in terms of energy performance due to constraints in the installation of insulation (Balaras et al., 2007). Greek residential buildings consume 25% of the total final energy and 73.6% of the total energy consumed of the whole Greek buildings sector (EC, 2004).

Greece introduced the ‘Saving at home’ scheme in 2011(YPEKA, 2013), which is a partly self-funded and partly government-funded scheme. There are a number of different requirements that need to be met, most of which are mainly income based, in order to be eligible to participate. Examples of the upgrades that are subsidised include the installation of external insulation, the change of old external doors and windows and the replacement of old boilers.

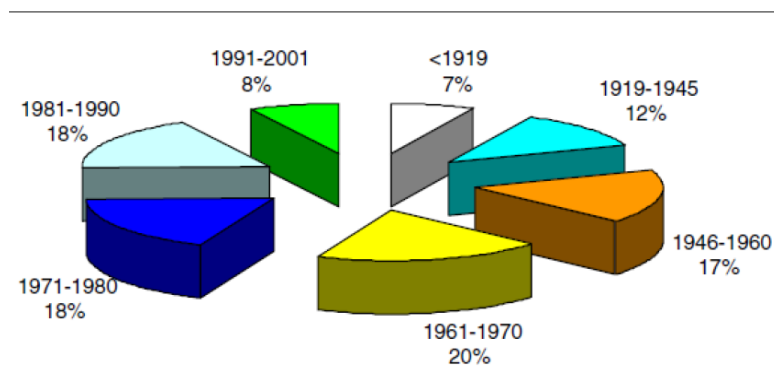

Figure 1. Age distribution of the Greek housing stock

Although the scheme is now well underway, it is still important to examine the condition of the housing stock in order to determine the exact size of the problem that the sector is facing and plan for the future. Furthermore, the cases of dwellings which have undergone upgrades should be analysed in order to evaluate the effectiveness of the whole scheme and to determine whether it performs as expected. Conclusively, an examination of how the upgrades have affected the lives of the users is undertaken.

2 Aims and methodology

The aims of this research are: a) To investigate the characteristics of the existing housing stock of Greece in terms of date and type of construction, size of households and to also look at its current energy performance based on case studies of dwellings for which an Energy

Performance Certificate (EPC) has been produced; b) To examine a number of the above-mentioned cases of dwellings, which were energy upgraded in Naousa, Greece in order to analyse the energy improvements they demonstrated, as well as to explore the importance of the different technologies that were applied to them; c) To monitor the thermal conditions of three of the upgraded houses during the summer period and examine whether the changes managed to provide a comfortable environment to the users; d) To investigate the behaviour of inhabitants of Naousa within their homes in terms of their thermal environment for better understanding the needs of the local population and for future reference (Palantzidis, 2013).

The first part of the research involved the gathering of data concerning the characteristics of the housing stock of Greece both in terms of energy performance and in terms of age, type, etc. Access to a total of 400 Energy Performance Certificates in electronic form was acquired from two private assessing companies.

Secondly a total of thirteen case studies of dwellings that underwent energy upgrade refurbishments were examined to draw conclusions in respect of their improvement.

In order to investigate how the energy upgrades affected the thermal comfort of the users, the thermal monitoring of three of the aforementioned dwellings was performed. The monitoring was performed with the use of thermal data loggers which were installed in each room of the monitored building for a period of one month from 01/07/2013 to 31/07/2013. The owners of the above-monitored dwellings were also given questionnaires which investigated their level of satisfaction with the result of the upgrades. The final part of this research analysed the answers of an occupancy survey from the inhabitants of the city of Naousa.

3 Results

3.1 Energy Performance of dwellings

More than 350.000 EPCs have been issued in Greece as of May 2013, for both residential and non-residential buildings. The first findings about the Greek stock based on data from the National registry of EPCs were finally published in June 2013 (Dascalaki et. al., 2013).

The dwellings are separated first in three groups based on their age and then they are separated further in terms of their climatic zone. The three age groups are inclusive of: buildings built prior to 1980 (buildings with no insulation), buildings built from 1980 to 2000 (buildings with inadequate insulation) and buildings from 2000 onwards, which are considered as having adequate insulation levels. As for the climatic zones, Greece is divided in four climate zones, defined on the basis of the number of Heating Degree Days (HDD), namely: Zone A (601–1100 HDD), Zone B (1101–1600 HDD), Zone C (1601–2200 HDD) and Zone D (2201–2620HDD).

More than 75% of the EPCs were issued in climate zones B and C, which is expected as the largest amount of the Greek population lives in them (Athens and Thessaloniki are in B and C respectively). Furthermore, in terms of age, nearly 50% of all EPCs were issued for buildings constructed before 1980. This is justified since these buildings represent the majority of the Greek housing stock.

The energy ranking is independent of climate zone. The predominant energy ranking is G, which is expected when considering the age of the Greek housing stock which suggests that a large number of buildings with no insulation (see Figure 2). Buildings with the lowest ratings were built prior to 1980. There are much fewer buildings built between 1980 and 2000 ranking in G and even less from 2000 onwards. In all climate zones, buildings that were constructed before 1980 and rank at G account for more than 50%, (51.8% in zone B and 53.2% in C). The predominant ranking for buildings built between 1980 and 2000 is D (ranging from 24.5 to 29.3%). Finally, most buildings built after 2000 ranked mainly in

category C and D (nearly 70% of buildings in zone B and 80% of buildings in zone C). This clearly shows that a large majority of even the newest dwelling fail to fulfil the requirements set by KENAK since 2010.

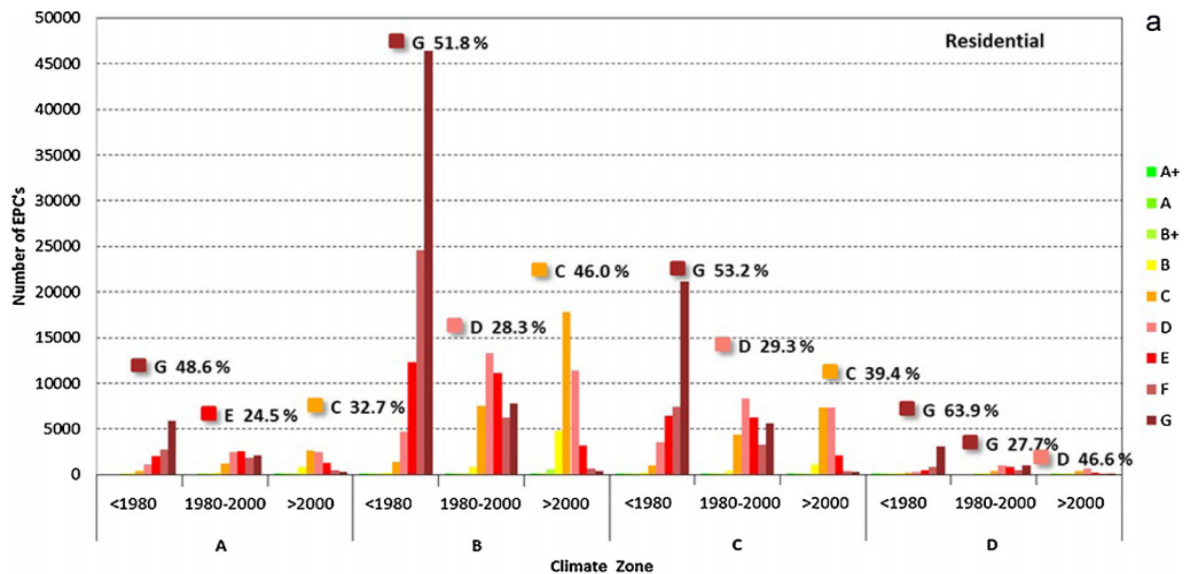

Figure 2. Detailed distribution of EPC class rank per climate zone [Source: Dascalaki et al., Energy and Buildings 65 (2013), 429-437]

In terms of energy consumption, the average consumption of the residential buildings is 260 kWh/m², with the thermal energy accounting for 72%. Zones C and D have as expected the largest consumptions since they are the coldest ones. The average primary energy increases progressively from 215 kWh/m² in zone A to 386 kWh/m² in zone D. (Dascalaki et al, 2013)

This paper also looks at EPC issued to 400 dwellings from Thessaloniki and Naoussa. Both cities are situated in the same climate zone C, which is considered as having cold winters and relatively cool summers (KENAK, 2010). 90.3% (361) of the four hundred dwellings are apartments (parts of multi dwelling buildings) while only 9.7% (39) are single houses. The mean age of the samples dwellings is 33 years old. The EPCs issued for buildings built prior to 1980 (buildings with no insulation), buildings from 1980 to 2000 (buildings with inadequate insulation) and for buildings built from 2000 onwards, were: 214 (53.5%), 118 (29.5%) and 68 (17%) respectively. These results are very close to the findings of Dascalaki et. al. (2013), (48.41%, 29.49% and 22.21% respectively).

Among the cases, the predominant energy class of the nine class scale of energy efficiency was G, the lowest possible, with 26% of the dwellings ranking as such. More than 98% of the examined dwellings belong in class C, D, E, F or G and are therefore characterized as energy inefficient. See Figure 3. In agreement with Dascalaki et al. (2013) findings, the older dwellings (built prior to 1980) which have no thermal insulation have the worst energy performance with most of them ranking in class G. When looking at newer buildings, the energy performance improves progressively, with buildings built after 2000 ranking mainly in class C.

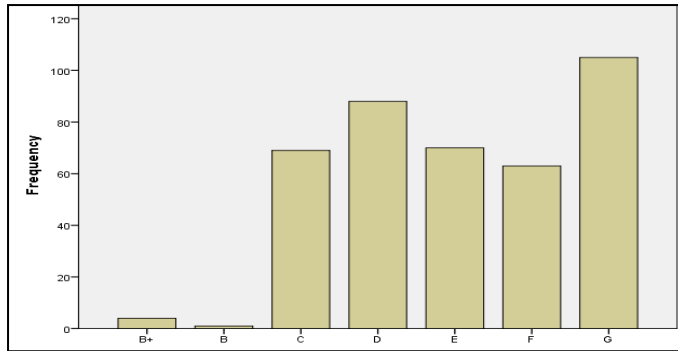

Figure 3. Energy rankings of examined cases

When comparing the results from this sample and the results of Dascalaki et al. (2013) both buildings that belong to the oldest age group and the ones that belong to the youngest, perform better than the average of new dwellings in climate zone C. Of the 5 dwellings in class B or better, none was built after 2010. This suggests that even older buildings can achieve high performances if the design was well thought and the application of insulation was performed according to the regulations in place. The dwellings that were built after 2010 ranked mostly in class C when according to legislation they should rank B or better. There are no cases of dwellings in categories A+ or A (see Figure 4).

The overall average consumption is 295 kWh/m² which is close to that estimated by Dascalaki. The average consumption of the three age groups (pre-1980, 1980-2000, after 2000) were 325, 269 and 245 kWh/m², respectively. As expected, the average consumptions of the oldest and newest groups, showcase a somewhat smaller than average consumption, while those from the middle age group showcase a consumption close to the average.

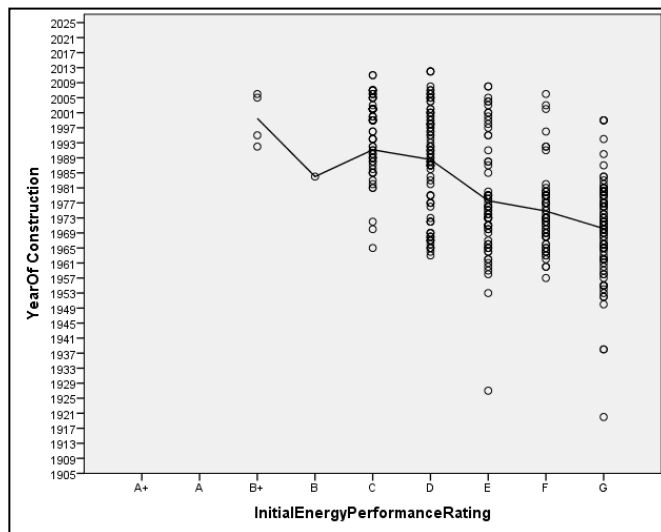

Figure 4. Energy performance and age relation trend

More than 98% of the dwellings from the oldest age group are ranked D or lower with most ranking as class G (38.32%). This percentage, although quite high is 15% lower than the finding of Dascalaki et. al. (2013) suggest, where it was found that 53.2% of dwellings of zone C ranked in class G. These findings suggest that the older stock of Naoussa and Thessaloniki performs better than that of the rest of zone's C. In the second age group (1980-2000) of the dwellings of Naoussa and Thessaloniki, the predominant ranking with 32.2% is class is D, in agreement to the overall stock of zone C where the percentage is sincerely close (29.3%). Finally, for the newest dwellings, the predominant class in Naoussa and Thessaloniki was class C at 45.59%. Class C was the predominant class of the stock of Zone

C of the same age group as well. The percentage in this case was 39.4%. This difference of nearly 6% suggests that like in the case of the oldest dwellings, the newer dwellings of Naoussa and Thessaloniki also perform better than the average. See Figure 5.

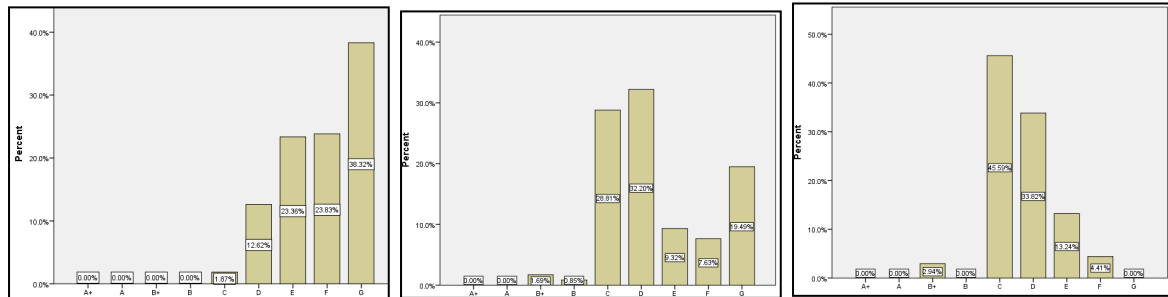

Figure 5. Energy class rankings of buildings built before 1980 (left) between 1980 and 2000 (mid) and after 2000 (right)

3.2 Upgrades in dwellings

Thirteen of the aforementioned four hundred cases, which were subjected to energy upgrades, were looked into in more detail. Further details can be seen elsewhere (Palantzidis, 2013). All the dwellings were built before 1987 and their mean agedate construction was 1972. 72.7% of all the cases initially ranked in energy class G and the average initial primary energy consumption was 440 kWh/m². After the upgrade, the mean primary energy consumption became 257 kWh/m², which is an improvement of 40%. The predominant class is now C. The dwelling with the initial lowest consumption (163 kWh/m²) was built in 1976 and the one with the largest (991 kWh/m²) in 1987.

The solutions applied at the upgrades can be defined in three categories: 1) Change of windows/installation of shading systems, 2) Installation of insulation and 3) new mechanical systems (boilers, solar thermal panels), each of which has several sub-categories. Among the examined cases, the most common solutions were the change of windows and balcony doors (22.9%), followed by the installation of external blinds (20.8%) and the installation of external insulation (16.7%).

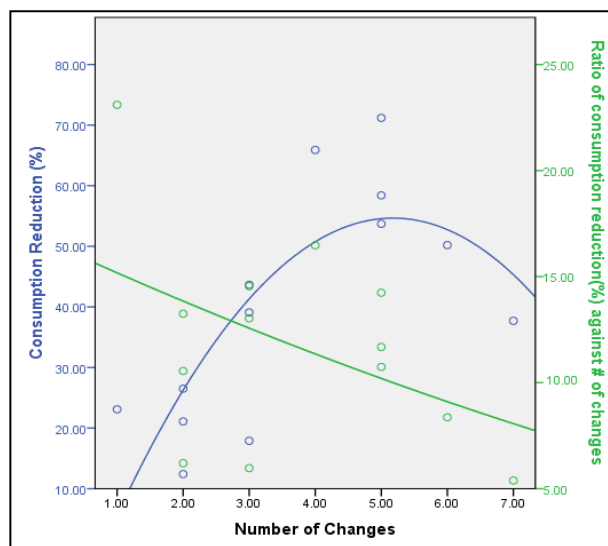

Figure 6. Relation of number of interventions with overall improvement

The blue trendline in Figure 6, reveals that the reduction of consumption (%) in a dwelling increases steadily and with a high rate for the first four to five changes but after that the addition of more changes does not appear to affect it significantly and actually a drop in

improvement is seen (although this drop should be overlooked as the sample is rather small for 6 or more changes and as a result the downward trend is non-significant).

It was also found that: a) the amount of investment plays a significant role in the overall improvement, but it does not guarantee an improvement in ranking, and b) the solution with the biggest impact in the improvement of the building's performance is the one performed first and each subsequent one has a lesser and lesser contribution. After the fourth or fifth intervention the improvement is minimal. A further examination of the relation between individual costs of solutions and subsequent overall improvement did not provide any concrete results for interventions coming from category 1 and 3 but it was found that there is a probable relationship between the investment on insulation and the consequential improvement in the energy class.

All the examined dwellings were rated E or worse with the majority of them (72.7%) belonging in category G.

What is very interesting is that the ranking of the dwellings did not necessarily change after the interventions, independently to whether the invested amount was large or small and independently to the decrease in consumption that was achieved, which in many cases showed great improvement in terms of actual energy consumption. For the case with the largest investment the dwelling still ranked as G after the interventions despite a reduction on the energy consumption from 991 kWh/m² to 285 kWh/m². In another case the dwelling improved from class F to class C and the overall improvement was near 44%, going from 271 to 152.8 kWh/m², the investment was almost a third of that of the former. Because every case is different, the amount of investment and the percentage of improvement does not guarantee that a building will improve based on current calculations.

3.3 Occupants role in the energy upgrade process

Although the attempts of the EU to reduce energy consumption in buildings are in the right direction, there is one major shortcoming. New regulations still not include the occupants' behavior characteristics and personal needs and user satisfaction. The collection of such feedback, has been found to offer 'valuable new insights', in other longitudinal studies of existing buildings (Lomas, K.J., 2009).

In the UK where the 'Green Deal', a retrofitting/energy upgrading scheme similar to many others in Europe, has been initiated, there hasn't been any analysis and integration of occupant feedback before proceeding to improve the existing housing, i.e. pre-refurbishment. "To improve the uptake and effectiveness of household energy efficiency and low-carbon interventions, it is essential and inevitable to address this current gap in knowledge" (Gupta and Chandiwala, 2010).

To continue with the example of the UK, it has been found that heating and electrical consumption can differ between similar dwellings (similar in terms of floor area, number of occupants by a factor of more than 3). For example, in a case study of a 'high performance' housing development, it was observed that depending on the behaviour of the users the difference in energy consumption for heating could go up to 50% and for electricity up to 37% (Gill et al, 2011). Keeping in mind that these dwellings had a similar design, it is becomes apparent that the behaviour of the occupants played a significant role.

In a different case study on the other hand, five houses which did not comply with the standards set by ASHRAE, did in fact achieve low energy use due to their occupants' behaviour (Williamson et al., 2010).

Stevenson and Rijal (2010) stress that, "the gap between estimated and actual energy performance in housing tends to increase rather than decrease following the installation of

energy-efficiency measures, partly due to people increasing their level of comfort beyond what was predicted. Evaluating the actual building performance of housing, taking account also of the relationship with user behaviour, can help establish some of the reasons for this gap and help to close it by suggesting design improvements related to these”.

The above showcases a very important aspect of the energy upgrade process which European and National authorities have, to a large extent, overlooked. This research attempted to collect feedback from both people that performed energy upgrade interventions to their homes as well as from users who did not. The collected information come from a relatively small sample of 35 people (12 with interventions, 23 without) and the findings analysed. Findings are not used to draw conclusions that shall be applied universally but rather to examine how people feel regarding dwellings improvements. If real data was also aquired then the role of people, with their different behaviours in similar dwellings, have in the energy consumption cloud be analysed (Gill et al. 2011).

The occupants’ evaluation regarding the upgrade of their homes was overall very positive. All the users replied that they were paying less or much less for their heating and cooling bills, that the problems they used to have, had been dealt with either completely or almost completely and that they felt that their investment paid off completely. In terms of thermal comfort, they replied that they never or almost never feel too cold during winter or too hot during summer and that they have no problems with drafts or with humidity levels. These responses present the whole upgrade as a success at least in the perspective of the occupants.

3.4 Environmental monitoring

The results of the monitoring of the thermal environment of three of the above energy upgrade cases were further examined. The monitoring took place during the summer of 2013. The mean temperature of the examined month was 25.6°C with the highest monitored external temperature, reaching 32°C. Overall, in all three cases the monitored temperatures of each dwelling’s rooms were found to be within the acceptable limits set by BS EN 15251 (BSI, 2007) for naturally ventilated dwellings and none of the dwellings faced any problems with either overheating or humidity levels. This along with the personal responses of the dwellings’ users which were positive indicates the good performance of the upgrade interventions. In the instance of case study 1, where it was possible to examine the living habits of the occupants in two different occasions and because they were energy-conscious, it was found that in general, they had adapted their habits according to the thermal environment and as a result avoided performing activities that would result in unsettling their thermal comfort. This could be seen by the stability of the measured temperatures throughout the examined month (Figure 7). The one occasion when the temperatures showed an extreme change, occurred when the occupant switched on an electrical appliance, which produced a lot of heat, i.e. tumble dryer.

In line with adaptive comfort theory, the rooms did not overheat. The analysis of the data and their comparison against the international (and local) standards it can be said that the dwelling in its current form performs particularly well during the summer and is comfortable. These findings are backed by the testimonies of the users themselves, which acknowledge that the environment of their dwelling has shown great improvement since the installation of the energy upgrade measures.

Unfortunately, monitoring of the dwelling during the winter period was not possible. The owners however, replied in the questionnaire that they are now paying less for heating and that they never feel cold.

Overall, it can be seen, that the energy upgrade in this case was successful both on paper but also in regards to the users' response, although there still is room for improvement especially in the winter period, by reducing consumption with the installation of a new efficient boiler. It seems that the thermal insulation and the installation of new windows, led to an effective management of the interior conditions during summer and these findings could potentially be extrapolated to the winter period, although winter monitoring of the house is still required. As previously highlighted the dwelling has shown significant improvement but it still only ranks category E.

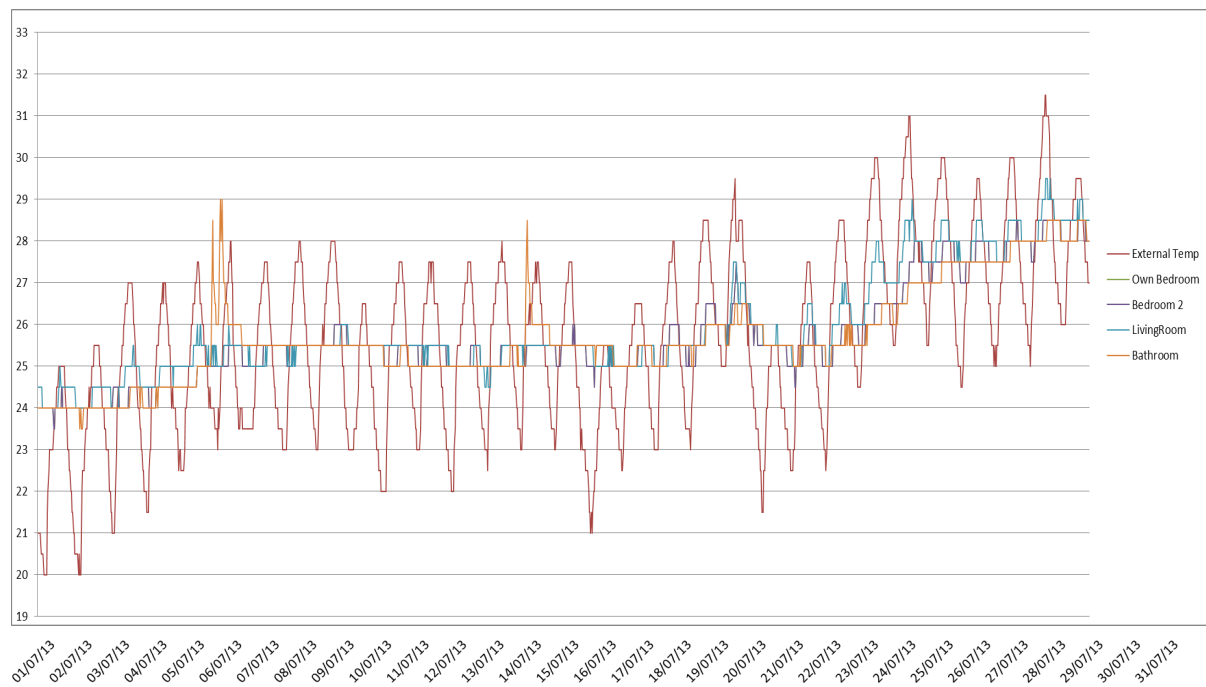

Figure 7. Monitored temperatures within the dwelling and outdoor in July 2013

Although the three examined cases share similar characteristics (case 1 and 3 have approximately the same year of construction, 2 and 3 have almost identical surface areas) they are still different and most importantly may face different occupant behaviour. Dwellings overall perform well in terms of thermal comfort during summer and it can be assumed that they will also perform better during winter and that their occupants have a positive outlook towards the whole process of energy upgrade. Moreover they now feel more comfortable than they did prior to the upgrades.

The temperature indoors, despite occasional spikes remains stable even in free running mode. In case 1 where the occupants' do not use an A/C unit and behave in accordance with the adaptive model's principles (ventilating during the night, closing the shutters while the sun is out, minimising activity levels, changing rooms depending where it is cooler) the measurement showed the most stable readings. In cases 2 and 3 where the dwellings were occupied by more users than in case 1 and where the users did not have the same living patterns (occasional opening of windows and balcony doors during daytime, use of A/C in some rooms), more variations were observed in the temperature measurements, but nevertheless the measured temperatures were found to be well within the acceptable range.

Apart from the comfortable thermal conditions, the occupants in all three cases expressed satisfaction with other aspects of their homes such as absence of drafts through windows, comfortable levels of humidity, as well as reduced heating and cooling bills.

After the above, it can be said that at least in terms of user satisfaction and living conditions' improvement the upgrades were very effective and can be deemed as successful.

It is also important to estimate/calculate the improvement the dwellings in terms of energy ranking and at what cost. In case 1, the dwelling went from category G to category E and there was an improvement of 21.1% with an investment of 3,593€. In case 2, the dwelling went from category F to category C with an improvement of 43.65% and with a cost of 6,402€. Finally in case 3, the dwelling went from category G to category D with a reduction of energy consumption of 50.2% at a cost of 13,174€. In all three of the instances, there was an improvement of at least two ranking places. It can also be seen that the amount of the investment substantially affects the eventual improvement but at the same time it needs to be remembered that different cases had a different consumption and had therefore (in case 3 for example) more room for improvement but also more need for improvement.

The biggest contributor to energy consumption in all cases is heating, which is expected from a climate like that of Northern Greece's. In all three cases the heating contributed more than 91% of the total energy load and in all three cases the heating was provided through systems that utilise diesel-oil. This still provides a significant scope for improvement.

4 Occupancy behaviour survey

Questionnaires were given to a total of 35 occupants of different dwellings in the city of Naoussa. The questionnaire included a series of questions which concerned: a) the demographics of the sample (i.e. age, sex, family size, etc.), b) the opinion the respondents had on their respective dwelling in terms of running costs and performance (i.e. heating and cooling bills, problems with overheating or excessive cold etc.), and c) the behaviour of the respondents within their dwelling during the heating and cooling period (i.e. frequency of natural ventilation during winter, existence and use of A/C units during summer etc.). The collected data were input in IBM's 'SPSS' statistical software in order to produce a series of analytical graphs. The results were then discussed and used to derive conclusions.

The sample of the occupancy survey was balanced with almost an equal number of men and women as well as quite diverse in terms of age, ranging from 24 to 69. The majority of the participants live with at least two more people, usually adults. On average the users stay indoors close to 8 hours during weekdays and eleven hours during Sundays, with women spending on average two hours more. The majority (60%) of the users replied that they *never* felt cold during winter while in the summer period 62.9% replied that they might feel *too hot*. This suggests that strategies adopted at the design of the local houses mainly addressed the problems of cold weather. More than half (57%) of the participants replied that they sometimes have high bills and the second most common answer being *Often* (17.1%). Close to 75% replied that they *never or only sometimes* have drafts in their homes, while 85.7% answered that they *never* encounter problems with humidity. When asked specifically about their heating and cooling bills, 71.5% thought that what they paid for heating was *normal* and 77.1% believed that their cooling bills were *low or very low*.

In terms of their behaviour within their homes in winter, the participants replied that they are usually dressed with a normal level of clothing (66%) or lightly (28.6%). When they feel that they are getting cold, they are more inclined to put more clothes on most of the time (close to 75%) rather than immediately turning the heat on (29% doing so often or very often). Finally, nearly 100% open their windows every day during winter for ventilation, with 45.7% doing so for less than half an hour but with also quite a few (17.1%) leaving them open for more than an hour, thus resulting in great heat losses.

Concerning the summer period, 66% (23) of the respondents own an A/C unit. Of these 23 people, 34% would turn their A/C unit on *often* or *very often* immediately after feeling hot, while the remaining 64% would only do that *sometimes*. More than 90% however replied that they would open windows in order to create a draft, *often*, *very often* or *sometimes*.

The analysis of the above findings showed that overall the surveyed occupants of Naoussa enjoy comfortable environments in their dwellings consider that the bills they pay are rational. The respondents were found to influence their environments to a great extent through their behaviour both in negative (heat losses during winter by opening windows) and positive ways (opting for natural cooling and ventilation during summer instead of using A/C). These findings are in agreement with previous research (Gill et al, 2011; Williamson, 2010; Stevenson and Rijal, 2010) which dictated that the users' behaviour affect their environment as well as the final consumption of a dwelling.

The users of dwellings upgraded have unanimously responded that not only do they spend less in heating and cooling but that the problems they used to have, have been completely addressed. Furthermore, they believe that their investment was well spent. When these responses are combined with the answers the occupants of upgraded dwellings gave concerning their comfort within their homes, it can be said that the occupants are content both with the financial and the comfort aspect of the upgrades. More specifically, all of the users of upgraded homes replied that they never or almost never feel cold during winter or hot during summer. Additionally, nearly 75% replied that they never or almost never have to deal with drafts or humidity in their home.

Analysis of the data obtained from the questionnaires, provide some very interesting results concerning the behaviour of the average occupant, results which can and should be used to the design more efficiently when it comes to energy upgrades or even completely new buildings.

Although the occupants do not in most cases face uncomfortable environments, at what cost do they achieve that? Almost 72% of the sample replied that they pay, as it appears to them, normal amounts of money for their heating, while a further 6% responded that they pay little or very little for it. That accounts for almost 8 out of 10 occupants believing that their comfortable environment comes at a reasonable expense.

This might seem contradicting to an extent when crossing the answers of the question *about how much they think they pay on utility bills*, where 26.5% replied that they paid high bills often or very often but in fact, since the utility bills include water and electricity, they are expected to be higher. In terms of other aspects of their homes beyond temperature, such as drafts from windows or doors, nearly 60% of occupants never encounter drafts; however there is a significant 25.7% who have drafts in their homes often or very often. Finally, an overwhelming 85.7% of occupants never had any problems with humidity levels and only 14.3% claimed that they occasionally do.

During the winter period, the majority (94.3%) of respondents are either normally or lightly clothed within their homes. If the occupants start feeling cold, 37.1% would turn up the heaters on occasion while another 22.9% would turn it up often. The option of wearing more clothes was also given and 31.4 % responded that they sometimes put on more clothes. 16% replied that they often or very often would put on more clothes. All these three combined are still lower than the probability of someone turning up the heat.

Someone could suggest that the behaviour of the users is due to the fact that they are not educated on energy efficiency matters and that they are irresponsible. When questioned on how they would behave if they felt cold, the majority replied that they would not raise the

thermostat but rather seek to wear more clothes. This behaviour agrees with the adaptive model and its claim about adaptive opportunity, which suggests that people will take actions in order to make themselves comfortable again (Nicol et al, 2012). The opening of the windows for ventilation during winter and for such a large time is therefore more a social habit and less a matter of personal irresponsibility.

Accordingly, during summer people appeared again to behave in an energy-conscious manner in most occasions, as they predominantly chose to avoid using an AC unit, even when they owned one. Here there is a reversed situation to that of winter, in the sense that users' actions save energy as they choose not to use the mechanical system.

An important lesson learned from the above survey is that the behaviour of the users plays a significant role in the eventual thermal comfort as well as the eventual energy use and correlate findings Gill et al's (2011) and Williamson et al's (2010) Unfortunately, Stevenson et al's claim that actual and estimated consumption do not coincide could not be tested due to absence of data.

5 Conclusions

European countries are committed to new buildings being Zero Energy by 2020. The biggest obstacle the member states have to address in reducing the energy consumption in buildings are existing buildings, mostly aged and with a high energy consumption. Governments have introduced funded retrofitting schemes for old buildings to motivate people to upgrade their homes and reduce their energy consumption. Greece introduced its own scheme 'Saving at Home' in 2010.

In a sample of 400 dwellings from Thessaloniki and Naoussa, the predominant energy class of the nine class scale of energy efficiency was G, the lowest possible, with 26.3% of the dwellings ranking as such. More than 98% of the examined dwellings belong in class C,D,E,F or G and are therefore characterized as energy inefficient. Older dwellings, have no thermal insulation and therefore have the worst energy performance with most ranking in class G. In newer buildings, the energy performance improves progressively however, buildings built after 2000 still mainly rank class C. The housing stock of the two examined cities is energy consuming and was shown to be even better than the wider country database. There is an urgent need to proceed with the energy upgrade of dwellings if Greece wants to meet with agreed commitments. First actions that have been taken so far in the form of the subsidized schemes result in great energy reductions with the national calculation. Actual monitoring of these dwellings is needed however in order to draw concrete conclusions.

Thirteen of the aforementioned four hundred cases, were subjected to energy upgrades. All the cases initially ranked in energy class G and the average initial primary energy consumption was 440 kWh/m². After the interventions the mean primary energy consumption was 257 kWh/m², which is an improvement of 40%. After the upgrade, the predominant class was C. The analysis of the frequency of interventions and of their respective cost found that a) the amount of investment plays a significant role in the overall improvement, but it does not guarantee an improvement in ranking, and b) the intervention with the biggest impact in the improvement of the building's performance is the one performed first and each subsequent intervention has a lesser and lesser contribution. Especially, after the fourth or fifth intervention the contributed improvement approaches zero. A further examination of the relation between individual costs of interventions and subsequent overall improvement did not provide any concrete results for interventions coming from category 1 and 3 but it was found that there probably is a connection between the investment on insulation and the eventual improvement.

Dwellings with an energy upgrade perform better and their occupants are satisfied with the results of the energy upgrade and well as the new environmental conditions. A questionnaire survey of the users' reaction to the interventions and to the thermal environment they encounter after the improvements highlighted that they have been unanimously positive. Nevertheless, no feedback is collected systematically and therefore there is lack of data from the majority of cases. Finally, the occupancy survey of the people of Naousa revealed how different habits of the users affect their thermal environment is in agreement to previous findings from others' research.

References

- Balaras C.A., Athina G. Gaglia, Elena Georgopoulou, Sevastianos Mirasgedis, Yiannis Sarafidis and Dimitris P. Lalas (2007) European residential buildings and empirical assessment of the Hellenic building stock, energy consumption, emissions and potential energy savings. *Building and Environment*, 42(3), pp 1298-1314.
- BPIE (2011) *Europe's buildings under the microscope*, Buildings Performance Institute Europe.
- BSI (2007) *Indoor environmental input parameters for design and assessment of energy performance of buildings addressing indoor air quality, thermal environment, lighting and acoustics*. BS EN 15251:2007. British Standards Institution.
- Dascalaki E.G., Kontoyiannidis S., Balaras C.A., Droutsas K.G., (2013) Energy certification of Hellenic buildings: First findings. *Energy and Buildings* 65, pp 429–437.
- DIR72/EC (2009) Directive 2009/72/EC of the European Parliament and of the Council of 13 July 2009, concerning common rules for the internal market in electricity and repealing Directive 2003/54/EC (Text with EEA relevance). Official Journal of the European Union, L211/55.
- EC (2004) European Union energy and transport in figures—2004 edition, Part 2: Energy. Brussels: Directorate General for Energy and Transport, European Commission.
- EPBD (2002) Directive 2002/91/EC of the European Parliament and of the Council of 16 December 2002, on the energy performance of buildings, Official Journal of the European Union, L1/65.
- EPBD-CA (2013) *Concerted Action Energy Performance of Buildings* [Online]. available at: <http://www.epbd-ca.eu/about> (accessed August 2013).
- EPBDrecast (2010) Directive 2010/31/EU of the European Parliament and of the Council of 19 May 2010, on the energy performance of buildings, Official Journal of the European Union, L153/13.
- Gill Z.M., Tierney M.J., Pegg I.M., Allan, N., (2011) Measured energy and water performance of an aspiring low energy/carbon affordable housing site in the UK, *Energy and Buildings*, 43(1), pp 117-125.
- GMECC (2009) Greek Ministry of Energy and Climatic Change, Κανονισμός Ενεργειακής Απόδοσης Κτιρίων, 2009.
- Gupta R. and Chandiwala S., (2010) Understanding occupants: feedback techniques for large-scale low-carbon domestic refurbishments. *Building Research & Information*, 38(5), pp530–548.

YPEKA (2013) *Ministry of Environment Energy and Climate Change*, [Online]. Available at: <http://exoikonomisi.ypeka.gr>, (accessed June, 2013).

Lomas, K.J., (2009) Carbon reduction in existing buildings: a transdisciplinary approach. *Building Research & Information*, 38(1), pp 1–11.

Nicol, J.F., Humphreys M.A. and Roaf, S.C., (2012) *Adaptive thermal comfort: principles and practice*. London: Earthscan/Routledge.

Palantzidis, K., (2013) *Current Energy Reducing Strategies for the Greek Housing Stock and the Role of the Occupant's Behaviour in achieving Energy Efficiency*. MSc Thesis. London Metropolitan University.

Stevenson F. and Rijal H.B., (2010) Developing occupancy feedback from a prototype to improve housing production. *Building Research and Information*, 38 (5), pp 549-563.

Williamson, T.J., Soebarto, V., and Radford, A.D., (2010) The thermal performance of five award-winning houses: regulated, measured and perceived. *Building Research & Information*, 38(5), pp 509–529.

Proceedings of 8th Windsor Conference: *Counting the Cost of Comfort in a changing world* Cumberland Lodge, Windsor, UK, 10-13 April 2014. London: Network for Comfort and Energy Use in Buildings, <http://nceub.org.uk>

Characterization of Thermal Comfort in a Passively Cooled Building Located in a Hot-Arid Climate

Alfredo Fernandez-Gonzalez¹

1 Natural Energies Advanced Technologies (NEAT) Laboratory, School of Architecture University of Nevada, Las Vegas, USA. alfredo.fernandez@unlv.edu

Abstract

This article compares the thermal performance and comfort levels produced by dry and wet roofponds monitored during the summer of 2011 in Las Vegas, NV. The measured data shows that under typical summer conditions, a dry roofpond with a depth of 15.24 cm. installed over typical U.S. residential construction is able to keep the maximum indoor operative temperature approximately 5.1 C° below the maximum outdoor air temperature, with the minimum indoor operative temperature remaining approximately 1.8 C° above the minimum outdoor air temperature. A wet roofpond with the same depth and construction characteristics is able to improve the performance of the dry roofpond by lowering the maximum indoor operative temperature an additional 3.4 C° (for a total reduction of approximately 8.5 C°), while also maintaining the minimum indoor operative temperature approximately 2.2 C° below the minimum outdoor air temperature. While neither one of the roofponds achieved comfortable conditions 100% of the time during the harsh summer conditions found in Las Vegas, NV, a wet roofpond applied to a better insulated one-storey house featuring ceiling fans might be able to reduce the uncomfortable period to a few hours per day during the hottest days of the summer season.

Keywords: Hot-Arid Climate; Passive Cooling; Roofponds; Thermal Comfort

1 Introduction

Passive solar heating and cooling strategies have been extensively researched in the United States for the past four decades. However, in spite of the documented successes and the innovative ideas generated through this research, most buildings in North America feature mechanical systems to satisfy the comfort expectations of their occupants. The energy used by the residential sector for space heating and cooling during 2009 in the United States was 5.12 million TJ (4.86 quadrillion Btu), and constituted 47.7% of all the site energy used by the residential sector (RECS, 2013).

The level of energy consumption of the residential sector in the United States will be difficult to sustain in an evolving world affected by climate change and by uncertain future energy supplies. To that end, it seems necessary to revisit the utilization of passive solar heating and cooling systems to satisfy the comfort requirements of residential buildings.

2 Perceived issues affecting the adoption of passive heating and cooling systems

If passive solar heating and cooling systems have been widely researched in the United States, why then are these systems not used in residential buildings? The answer to this question is certainly complex, as there are real and perceived issues

raised by various constituencies. For example, in the United States the home financing sector generally requires residential developers to install mechanical cooling systems. Consequently, given the extended use of mechanical cooling, the general public is unaware of other passive and hybrid options for space conditioning. But more importantly, there is real scepticism among architects and designers in the United States regarding the use of passive heating and cooling systems as these are not explicitly addressed (with the exception of natural ventilation) in ASHRAE's Standard 55 (ASHRAE, 2010). This issue is of particular importance for those passive strategies that rely on radiation as the primary means to produce comfortable conditions (Fernández-González, 2007).

The lack of information about comfort in passive buildings is exemplified in the Load Collector Ratio (LCR) method proposed by Balcomb et al. (1984). The LCR method is the most widely used guideline for the design and prediction of the thermal performance of passive solar heated buildings in the United States. The LCR method does not provide conclusive information about the thermal conditions (air and mean radiant temperatures as well as air velocity) produced by the various strategies included in the guideline. Moreover, the conditions suggested by the LCR method are assumed to be the same across the whole floor area, giving therefore an estimate of the lumped conditions throughout the space. This characteristic of the LCR method, as pointed out by Messadi (1998), makes it miss the dynamic aspects that characterize thermally-massive passive solar buildings, and this is precisely the most important concern if one were to look at passive solar buildings from the thermal comfort standpoint. It could be argued that at the time in which the LCR method was developed, the main concern was to save energy, and therefore, that is why this method doesn't pay much attention to thermal comfort and how it could be evaluated or characterized. Nonetheless, by having put thermal comfort as a secondary concern, the LCR method made passive solar buildings an "alternative" practice. The same issue also hinders the adoption of those cooling strategies that rely on radiation as the primary means to provide comfortable conditions.

To address this lack of information with respect to the thermal conditions produced by roofponds, a heating and cooling strategy that relies on ceiling temperatures to produce a comfortable environment, this paper presents a summary of the experimental results obtained during the summer of 2011 using two different cooling configurations of the roofpond strategy in a hot-arid climate.

3 Basic roofpond principles

The roofpond system, conceived and developed by Harold Hay (Hay and Yellot, 1968), is an indirect gain strategy for heating and cooling consisting of a thermal storage roof holding water within transparent polyethylene bags (hence the name of "roofpond"). Under the thermal storage roof, a black EPDM liner is required for water proofing and to properly absorb and convert solar radiation into useable heat during the wintertime. The system generally requires movable insulation panels above the thermal storage roof to cover it during winter nights or summer days. The movable insulation is in fact what allows this strategy to perform in both heating and cooling modes, by allowing the system to avoid unnecessary winter heat losses or undesired summer heat gains through the thermal storage roof.

Given that the thermal collection, storage, transfer and control takes place on the roof surface of the building, the ceiling under the roofpond must have high thermal

conductivity to facilitate the heat exchange between the occupied living space and the roofpond above. Since metal deck is a common, widely available construction material, it is often used as the structural ceiling in roofpond buildings given its high thermal conductivity and structural strength to support the added weight of the roofpond system. As a heating and cooling strategy, roofponds work well because they mimic the ways in which nature tempers and controls the global climate (Givoni, 1994; Hay and Yellot, 1970).

3.1 Heating mode

In its heating mode, the movable insulation is removed from the roofpond to expose it to incoming solar radiation between the hours of 9:00 AM and 3:00 PM (solar time). The solar radiation is then absorbed and converted into useful heat at the surface of the black liner. While most of the heat is then transferred to the roofpond, a fraction of this heat is immediately transferred to the occupied living spaces under the thermal storage roof. If there isn't enough solar radiation during the day, the movable insulation may cover the roofpond, acting much in the same way as a "cloud cover" that minimizes the radiation losses to the sky. Similarly, at night the movable insulation covers the roofpond to minimize heat losses so that the energy collected during the day remains in the roofpond so that it can be radiated throughout the night to the occupied spaces below.

3.2 Cooling mode

In cooling mode, the movable insulation covers the roofpond during daylight hours, thus minimizing undesirable solar heat gains through the roof. Throughout the entire day the roofpond absorbs and stores the heat that is generated within the building and also the heat that penetrates through the building envelope. As the day progresses, the roofpond temperature slowly increases until it reaches its maximum temperature, which in a well-designed roofpond would be approximately 26 °C (79 °F). It is at this point that the movable insulation is removed to expose the roofpond to the night sky. Just as our planet re-radiates heat back to space, the roofpond emits long-wave radiation using the night-sky as heat sink. A properly designed roofpond can reject all the heat that was gained by the building during the daytime, lowering the roofpond temperature enough for it to be able to repeat the process the following day.

3.3 Operation during "swing" seasons

During transitional periods (generally in the spring and fall), the movable insulation typically covers the roofpond throughout the entire day. During these times, the ambient temperature approaches the comfortable range and the thermal mass of the roofpond is used to "stabilize" the indoor temperature by absorbing the heat that is generated within the building, transferring it back to the occupied living spaces at night.

4 Types of roofponds

Different types of roofponds have been developed to achieve the best possible performance in different climatic regions. Based on the way in which they contain and use water, roofponds can be classified in three different categories: dry, wet, and open.

Dry roofpond: A roofpond in which the water is contained in plastic bags and no water is exposed to the environment. This type of roofpond may be exposed to the

outdoor environment or contained within an attic. While dry roofponds are adaptable to both heating and cooling applications, their cooling potential is limited in very hot or humid environments.

Wet roofpond: A roofpond in which water is contained in plastic bags, which are then flooded or sprayed when additional cooling is desired. By wetting the surfaces of the bags that are exposed to the environment cooling occurs by both radiation to the night sky and by evaporation. This type of roofpond is used only for cooling purposes, but may be adaptable for heating if the water covering the surface of the plastic bags is drained.

Open roofpond: A roofpond system in which the water is not contained in bags but rather it exists as an open pool within the boundaries of the roof parapet. This type of roof pond is used only for cooling applications. Because of its evaporative losses, this type of roofpond requires constant replenishment of the water body. This type of roofpond may be exposed to the outdoor environment or contained within an attic. The former approach requires constant maintenance to keep the water from developing algae or accumulating debris. When contained within an attic, an open roofpond is only cooled by evaporation and therefore it requires sufficiently large inlet and outlet vents.

With respect to their containment within the roof, roofponds are divided in two different systems: exposed and enclosed roofponds. These two configurations respond to the construction methods necessary to accommodate winter climatic conditions.

Exposed roofpond: A roofpond system in which the movable insulation panels are the only barrier between the pond and the environment. This configuration may be used in both heating and cooling applications, however it is only recommended for locations with less than 10 cm. (4 inches) of snow precipitation per year, and with a mean monthly minimum ambient temperature for January above 0 °C (32 °F).

Enclosed roofpond: A roofpond system that is totally enclosed in an attic space. Generally, this type of roofpond features sufficiently large equator-facing skylights to collect solar radiation during the winter months. This application is mainly used where heating loads are predominant and winter conditions require that the roofpond remain confined within the building envelope. This type of roofpond also requires the use of movable insulation to prevent losses through the glazing in the wintertime (or solar heat gains during the summertime).

In spite of all these differences, all roofponds use the same operating principles described earlier in this article. To determine the ideal depth of a pond one needs to examine local climatic conditions. Marlatt et al. (1984) suggests pond depths between 10 and 25 cm. (4 and 10 inches), but in colder climates depths over 30 cm. (12 inches) are not uncommon (Fernández-González, 2007).

5 Roofpond system components

Water Bags: The thermal storage on a roofpond building typically consists of water enclosed in plastic (e.g., clear 6 mm. UV treated polyethylene) bags. The water does not circulate in and out of the bags at any time, as the bags are permanently sealed. Given that the bags are only exposed to solar radiation during the heating season, the lifespan of the water bags is somewhere between two and four times the stated duration of the UV protection (which assumes daily exposure to solar radiation).

Most UV protected polyethylene plastics are guaranteed for four years, and therefore their expected lifespan in a roofpond building would be anywhere between eight to sixteen years. In the United States, a conventional flat-roof is generally resurfaced once every ten years, so the roofpond system is well within that range.

Liner: The liner that waterproofs the metal deck should be made of black Ethylene Propylene Diene Monomer (EPDM). The liner's guaranteed life is twenty years under full exposure to weather elements. In a roofpond application the life of the liner is extended somewhere between 1 ½ and 2 times the guaranteed life of the liner. Ideally, the EPDM liner should be installed in a way that an entire piece covers the whole roof area. While this may be difficult to do, minimizing the number of seams helps prevent leaks or condensation problems.

Movable insulation: The design of movable insulation panels has been historically the biggest problem in roofpond buildings (Givoni, 1994; Marlatt et al., 1984). This is particularly true in exposed roofponds, where the movable insulation is deployed horizontally, and it is constantly exposed to outdoor weather elements. Recent research at the University of Nevada, Las Vegas shows that the use of standard garage door components automatically operated by a programmable timer can be satisfactorily used to meet the demands of a roofpond (Fernandez-Gonzalez, 2007).

6 Experimental results

This article compares the conditions produced by dry and wet roofponds monitored during the astronomic summer (June 21st through September 21st) of 2011. The results presented in this section were experimentally measured at the Natural Energies Advanced Technologies (NEAT) Laboratory of the University of Nevada, Las Vegas.

6.1 Experimental setup

The experimental setup consisted of two identical test cells, each featuring a 15.24 cm. (6 inches) deep exposed roofpond (see Figure 1). The only difference between the two roofpond test cells was that one featured a dry roofpond (see Figure 1e) while the other had a wet roofpond (see Figure 1d), with water sprayed at night in order to take advantage of indirect evaporative cooling. Both test cells have interior dimensions of 1.3 m. (4'-3") by 2.1 m. (6'-10") and a floor-to-ceiling height of 2.4 m. (8'-0"). A corrugated metal deck is used as structural ceiling. Thermacore® automated garage doors provide the movable insulation for the roofponds (see Figure 1b). The R-value of the movable insulation used in this experiment is 1.94 K•m²/W (11 h•ft²•°F/Btu).

6.2 Operation of the test cells

Between June 12th and August 20th, the movable insulation covered the roofponds between 6:00 AM and 8:00 PM (Local Standard Time). The movable insulation panels were retracted at 8:00 PM, when the environment was cooler and could begin to absorb the heat gained by the roofponds throughout the day. On August 21st the movable insulation cycle was changed and the roofponds were covered from 6:30 AM until 7:30 PM. This change gave the roofponds one additional hour to dissipate the heat absorbed during the day. Starting on September 11th the operation cycle was modified once again and the movable insulation covered both roofponds between 7:00 AM and 7:00 PM. Both test cells also featured an exhaust fan operated to maintain a ventilation rate of 1 ACH.

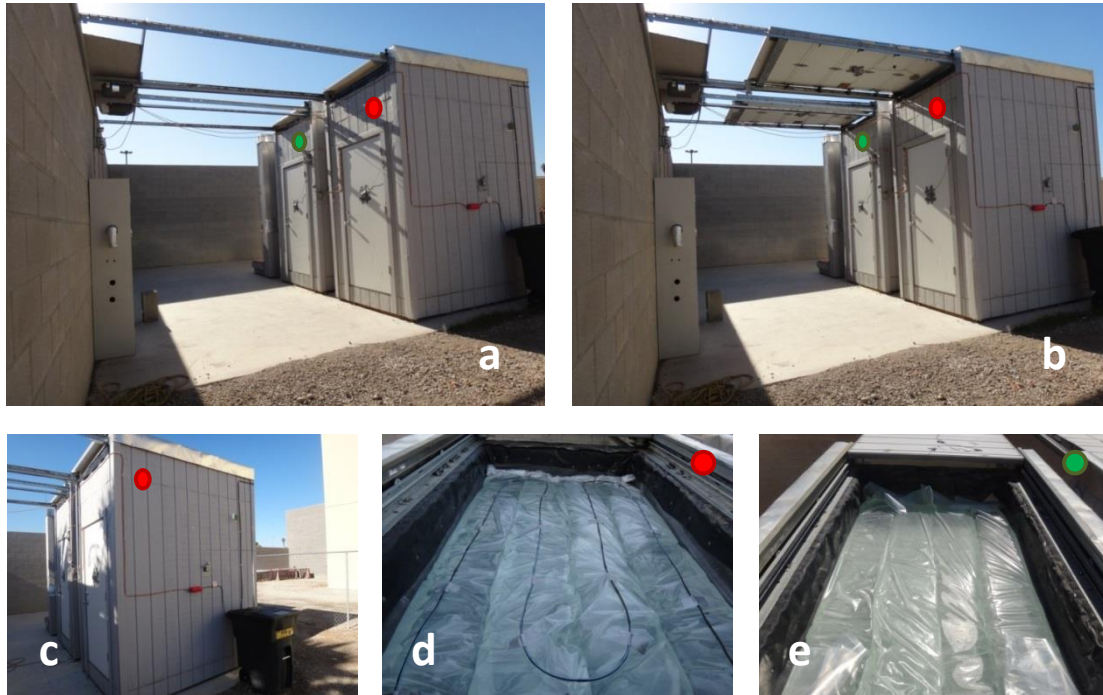

Figure 1. Wet (*red dot*) and Dry (*green dot*) Roofpond test cells at the University of Nevada, Las Vegas.

To spray the wet roofpond, water was pumped from an adjacent storage tank (see Figure 1c) and delivered to its upper surface using a drip irrigation system (see Figure 1d). This procedure started on June 18th and was continued until the end of the experiment. During the first week in which the wet roofpond was sprayed with water 37.9 litres (10 gallons) were delivered per night to assist with its cooling. However, after careful observation it was noted that a maximum of 11.4 litres (3 gallons) could be successfully evaporated per night. Therefore, 11.4 litres (3 gallons) were used for the remainder of the experiment. This amount corresponds, approximately, to 3.2 litres / m² (1 gallon / 10 ft²) of roofpond surface area.

6.3 Overall summer performance

The experimental results obtained during the summer of 2011 confirm that both roofpond types are able to provide remarkable indoor thermal stability, which is in many ways a prerequisite for a building to be considered comfortable. While the average outdoor air diurnal temperature swing during the studied period was 11.3 C° (20.4 F°), the daily average indoor operative temperature swing within both roofponds was below 5 C° (9 F°).

Figure 2 illustrates the hourly outdoor air and humidity conditions measured throughout this study. The highest hourly outdoor air temperature measured during the summer of 2011 was 44.2 °C (111.6 °F), while the lowest hourly outdoor air temperature was 18.6 °C (65.4 °F). The lowest temperature occurred during a rainy night in the middle of the “monsoon” season. A comparison of the hourly outdoor conditions measured throughout the experiment and the graphic comfort zones provided by the ASHRAE Standard 55 in its 2004 and 2010 versions suggest the use of evaporative cooling as the ideal strategy for this climate. However, because water is generally scarce in hot-dry regions, dry and/or wet roofponds could become an attractive passive, low-water use alternative to produce comfortable indoor conditions.

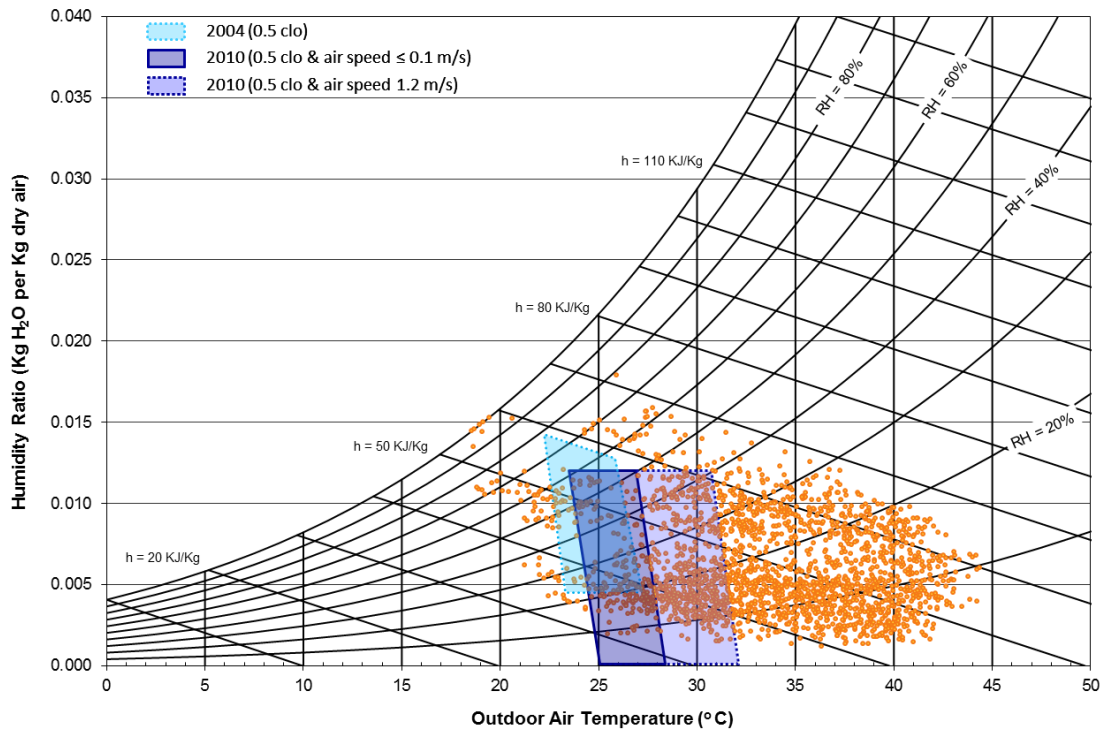

Figure 2. Summer of 2011 hourly outdoor air temperature and humidity compared to the graphic comfort zones provided by the ASHRAE Standard 55 in its 2004 and 2010 versions.

Figures 3 and 4 compare the hourly indoor operative temperatures measured throughout the summer in the dry and wet roofponds, respectively, and the ASHRAE Standard 55 graphic comfort zones in the 2004 and 2010 versions of this standard. While the comparisons presented in Figures 3 and 4 demonstrate that neither roofpond achieved comfortable conditions 100% of the time, the results obtained in this study (particularly those for the wet roofpond) are quite promising given the unusual ceiling to wall ratio of the test cells and the less than ideal construction of the experimental prototypes (e.g., a steel door with an R-value of $0.881 \text{ K}\cdot\text{m}^2/\text{W}$ ($5 \text{ h}\cdot\text{ft}^2\cdot^\circ\text{F}/\text{Btu}$) constitutes approximately 15% of the entire wall area of each prototype).

6.4 Average hourly summer performance

Figure 5 presents a comparison between the summer average hourly outdoor air temperature and humidity and the summer average hourly operative temperatures measured inside the dry and wet roofpond test cells. The information in Figure 5 shows that the average maximum outdoor air temperature for the summer was $38.6 \text{ }^\circ\text{C}$ ($101.6 \text{ }^\circ\text{F}$), while the average maximum indoor operative temperature for the dry roofpond was $33.5 \text{ }^\circ\text{C}$ ($92.3 \text{ }^\circ\text{F}$), displaying a temperature reduction between the exterior and the interior of approximately $5.1 \text{ }^\circ\text{C}$ ($9.2 \text{ }^\circ\text{F}$). The nightly evaporation of approximately 11.4 litres (3 gallons) of water helped further reduce the average maximum indoor operative temperature within the wet roofpond to $30.1 \text{ }^\circ\text{C}$ ($86.2 \text{ }^\circ\text{F}$), for a total reduction of $8.5 \text{ }^\circ\text{C}$ ($15.4 \text{ }^\circ\text{F}$) below the average maximum outdoor air temperature.

A comparison between the summer average minimum outdoor air temperature of $27.3 \text{ }^\circ\text{C}$ ($81.2 \text{ }^\circ\text{F}$) and the average minimum indoor operative temperature measured within the dry roofpond of $29.1 \text{ }^\circ\text{C}$ ($84.5 \text{ }^\circ\text{F}$) demonstrates that without the assistance

of night-time evaporation, minimum indoor operative temperatures remain approximately 1.8 C° (3.3 F°) above the outdoor minimum air temperature.

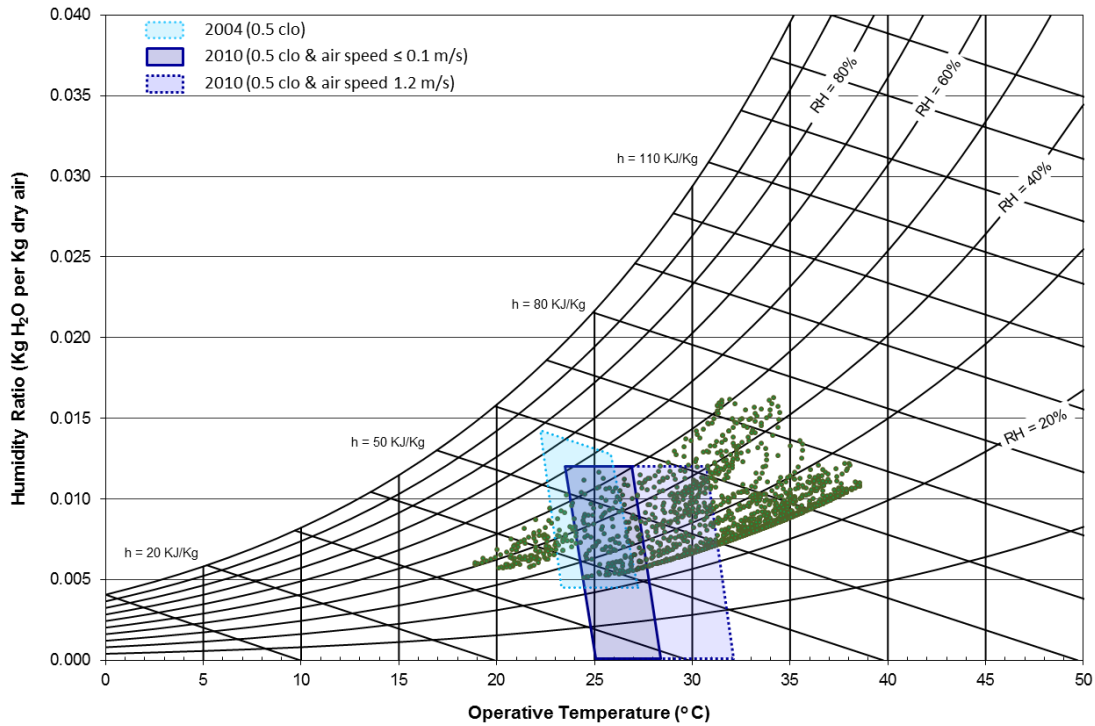

Figure 3. Comparison of the hourly indoor operative temperatures produced by a dry roofpond and the graphic comfort zones provided by the ASHRAE Standard 55 in its 2004 and 2010 versions.

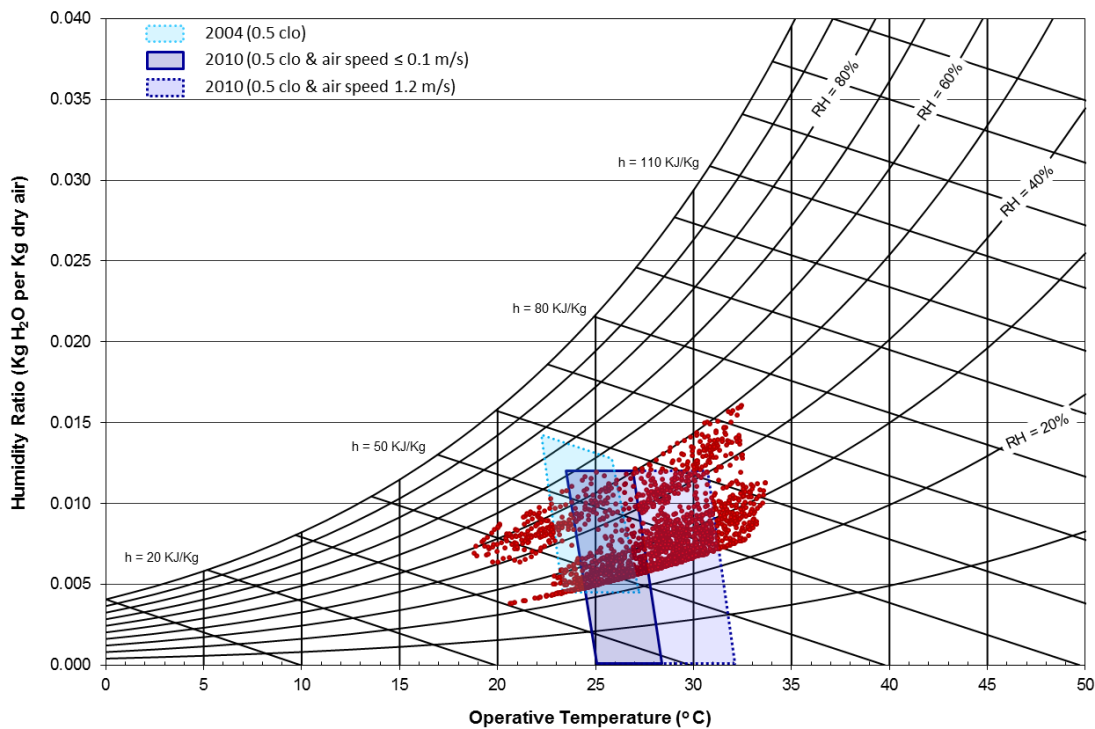

Figure 4. Comparison of the hourly indoor operative temperatures produced by a wet roofpond and the graphic comfort zones provided by the ASHRAE Standard 55 in its 2004 and 2010 versions.

However, once night-time evaporation is introduced, the indoor operative temperature of a wet roofpond remains practically at all times below the outdoor air temperature, achieving a reduction of its average minimum operative temperature of almost 2.2 C° (4 F°) below the average minimum outdoor air temperature (see Figure 5).

6.5 Performance during the hottest summer day (August 24, 2011).

In a typical Las Vegas' summer, the daily maximum outdoor air temperature continues to rise until it reaches its highest values during the month of August. It is during this part of the summer that both roofponds deliver their best performance. Figure 6 illustrates the behaviour of dry and wet roofponds during August 24th, 2011, which was the day with the highest outdoor air temperature during the period examined in this paper.

A comparison between the daily maximum outdoor air temperature of 44.3 °C (111.8 °F) and the daily maximum indoor operative temperature of 37.9 °C (100.3 °F) within the dry roofpond shows a temperature reduction of 6.4 C° (11.5 F°). While this reduction is significant, the operative temperature measured inside the dry roofpond test cell remains outside the comfort zone during the entire day (see Figure 6). The nightly evaporation of approximately 11.4 litres (3 gallons) of water produced a daily maximum indoor operative temperature within the wet roofpond of 32.9 °C (91.3 °F), for a temperature reduction of 11.4 C° (20.5 F°) below the daily maximum outdoor air temperature. This temperature reduction allows the wet roofpond to remain comfortable during 16 hours of the day. A comparison between the daily minimum outdoor air temperature of 29.2 °C (84.5 °F) and the daily minimum indoor operative temperature measured within the dry roofpond, in this case 32.3 °C (90.2 °F), shows that during the hottest day of the summer the dry roofpond's minimum indoor operative temperature remains 3.2 C° (5.7 F°) above the daily minimum outdoor air temperature. The minimum indoor operative temperature measured within the wet roofpond during the hottest day of the summer was 27 °C (80.6 °F), remaining almost 2.2 C° (4 F°) below the daily minimum outdoor air temperature (see Figure 6).

7 Conclusions

The results presented in this paper suggest that under typical summer conditions, a dry roofpond installed over typical U.S. residential construction is able to keep the maximum indoor operative temperature approximately 5.1 C° (9.2 F°) below the maximum outdoor air temperature, with the minimum indoor operative temperature remaining approximately 1.8 C°(3.3 F°) above the minimum outdoor air temperature. A wet roofpond is able to improve the performance of the dry roofpond by lowering the maximum indoor operative temperature an additional 3.4 C°, for a total reduction of approximately 8.5 C° (15.4 F°), while also maintaining the minimum indoor operative temperature approximately 2.2 C° (4 F°) below the minimum outdoor air temperature.

The measured and calculated temperatures presented in this article demonstrate that a wet roofpond could be a powerful strategy to provide the majority (if not all) of the space cooling needed by a building with low to moderate internal heat gains in Las Vegas, Nevada. During the hottest (and therefore driest) part of the summer, the dry and wet roofponds exhibited their best performance. During the hottest day of the summer, the wet roofpond achieved a reduction of approximately 11.4 C° (20.5 F°) between the maximum outdoor air and indoor operative temperatures.

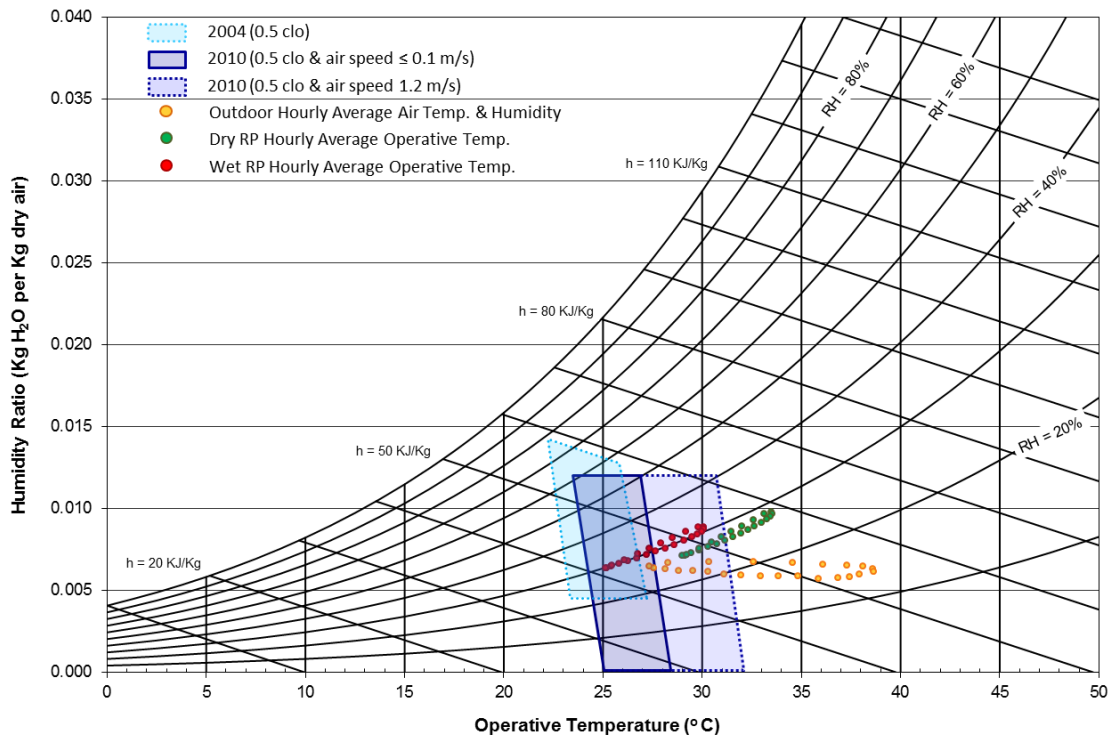

Figure 5. Average hourly outdoor air temperature and humidity and average hourly operative temperatures from the dry and wet roofponds for the summer of 2011.

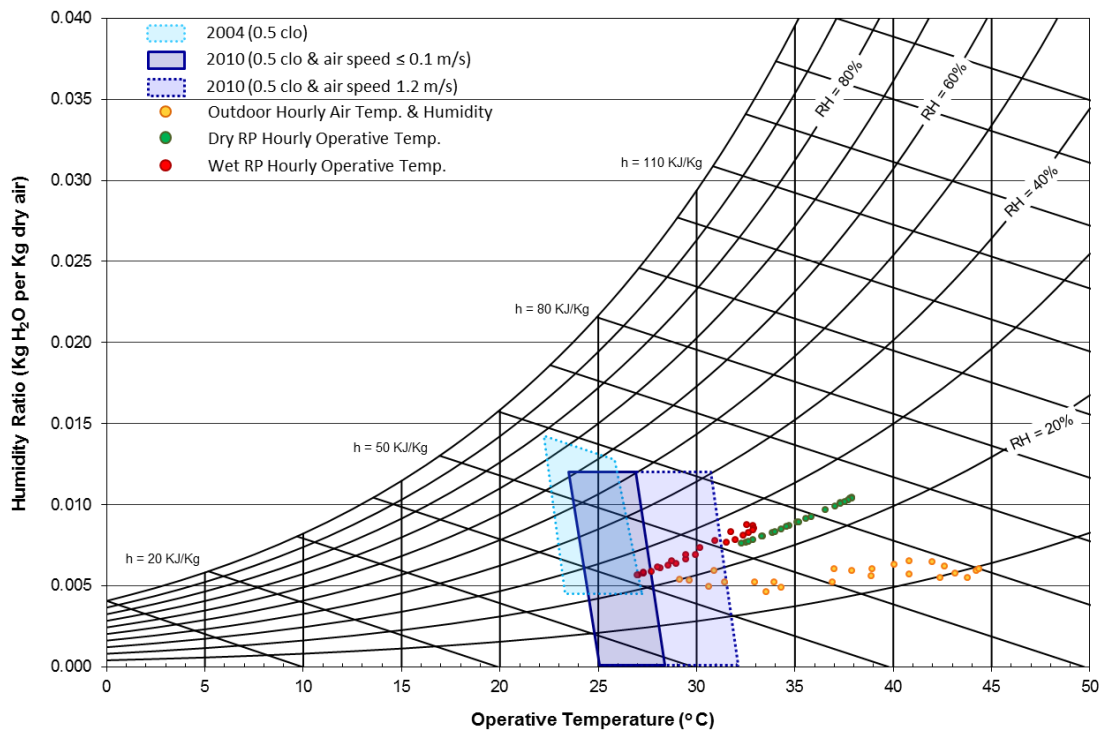

Figure 6. Hourly outdoor air temperature and humidity and coincident operative temperatures of the dry and wet roofponds measured during the hottest day of the summer (August 24, 2011).

During periods of rain and/or high humidity the reduction between the maximum outdoor air and indoor operative temperatures decreases. However, during these times the outdoor air temperature typically registers lower values.

It is important to note that the minimum operative temperature of the wet roofpond remained during the hottest part of the summer approximately 2.2 C° (4 F°) below the minimum outdoor air temperature. It is also worth noting that the ceiling temperature inside the wet roofpond was, in average, 3.4 C° (6.1 F°) lower than the indoor operative temperature, thus providing a cool ceiling that is able to absorb heat from within the space at all times while remaining an effective source for radiant cooling. The ceiling's positive contribution to thermal comfort would be amplified in a building featuring a typical ceiling to wall ratio.

Simple design and/or construction improvements to the test cells, such as reducing infiltration from 1 ACH to 0.6 ACH, coupling the building to the ground, or increasing the R-value of building envelope components, should improve the results obtained in the summer of 2011.

Finally, the experimental results presented in this paper are compared to energy and water consumption figures modelled for several cooling strategies suitable for single-storey buildings in the United States Southwest. Table 1 summarizes and compares:

- a) the energy used for cooling (in KWh/m²) for wet and dry roofponds (based on actual, experimental data); three evaporative cooling strategies (passive downdraft, direct, and two-stage); and three compressive refrigeration systems (unitary roof-top, packaged central plant with air cooled condenser, and packaged central plant with water cooled condenser). The modelled results for the evaporative and compressive refrigeration systems are taken from Bryan (2004) and correspond to a single-storey building in the city of Phoenix, Arizona.
- b) the indirect, consumptive water use (in Litres/m²) attributable to the production of the electricity needed by each of the cooling options. Table 1 uses a water consumption value of 27.44 litres/KWh (7.25 gal/KWh), which corresponds to the average evaporative losses for electricity production in the State of Nevada (Torcellini et al., 2004).
- c) the direct, site water consumption (in Litres/m²) based on actual, experimental data for the roofponds and on values reported by Bryan (2004) for the other cooling strategies.

Table 1. Energy and water consumption of active, hybrid, and passive cooling strategies appropriate for single-storey buildings located in a hot-dry climate (with data from Bryan, 2004).

Cooling Strategy	Energy Use (KWh / m²)	Water Use at Plant (Litres / m²)	Water Use at Building (Litres / m²)	Total Water Use (Litres / m²)	Thermal Comfort (Quality)
Unitary roof-top air conditioners	52.54	1,441.8	0.0	1,441.8	High
Packaged central plant with air-cooled condenser	46.03	1,263.3	0.0	1,263.3	High
Packaged central plant with fluid cooler	40.63	1,115.1	213.5	1,328.6	High
Two-stage evaporative cooler	20.53	563.5	223.3	786.8	Moderate
Direct evaporative cooler	15.62	428.6	241.2	669.8	Low
Evaporative Cool Tower	0.71	19.5	290.1	309.6	Low
Wet roofpond	0.48	13.1	384.0	397.1	Low
Dry roofpond	0.42	11.4	0.0	11.4	Low

The results from this comparison show that roofponds use the least amount of energy from all the systems studied. Furthermore, the wet roofpond uses almost as little water as the passive downdraft (Cool Tower) strategy, with the former having better indoor humidity control during the “monsoon” season. For these reasons, and based on the results presented in this paper, roofponds deserve further investigation and eventual deployment in hot-arid regions where electricity and water may be scarce.

In terms of thermal comfort, the three cooling strategies that rely on compressive refrigeration can easily provide the thermal conditions required by ASHRAE Standard 55. Therefore, these systems are assumed to provide a high degree of thermal comfort (Bryan, 2004). Of the evaporative cooling strategies, the two-stage evaporative cooler provides the best thermal conditions, as it can control indoor temperatures as well as humidity. The direct evaporative and passive downdraft (Cool Tower) strategies have poor humidity control, which renders them ineffective during periods of high humidity and rain. While the wet and dry roofponds failed to produce comfortable conditions 100% of the time, the improvements discussed earlier in this section should help the strategy move from “low” to “moderate” comfort without great difficulty or expense in the extremely challenging environment of Las Vegas, Nevada.

References

ASHRAE. 2010. *ANSI/ASHRAE 55-2010: Thermal Environmental Conditions for Human Occupancy*. Atlanta, GA: American Society of Heating, Refrigeration, and Air-Conditioning Engineers.

ASHRAE. 2004. *ANSI/ASHRAE 55-2004: Thermal Environmental Conditions for Human Occupancy*. Atlanta, GA: American Society of Heating, Refrigeration, and Air-Conditioning Engineers.

Balcomb, J.D., Jones, R.W., McFarland, R.D., and Wray, W.O. 1984. *Passive Solar Heating Analysis: A Design Manual*. Atlanta, GA: American Society of Heating, Refrigeration, and Air-Conditioning Engineers.

Bryan, H. 2004. Water Consumption of Passive and Hybrid Cooling Strategies in Hot Dry Climates. *Proceedings of the 33rd American Solar Energy Society National Conference*. Boulder, CO: American Solar Energy Society.

Fernández-González, A. 2007. Analysis of the Thermal Performance and Comfort Conditions Produced by Five Different Passive Solar Heating Strategies in the United States Midwest. *Solar Energy*, 81(5), pp 581-593.

Givoni, B. 1994. *Passive and Low Energy Cooling of Buildings*. Hoboken, NJ: John Wiley & Sons Inc.

Marlatt, W.P., Murray, K.A., and Squier, S.E. 1984. *Roof Pond Systems*. Canoga Park, CA: Energy Technology Engineering Center.

Messadi, T. 1998. Mathematical Simulation for Correct Coupling of Direct Solar Gain to Thermal Mass Inside a Prototypical Space. *Proceedings of ASHRAE Annual Conference on Thermal Performance of the Exterior Envelopes of Buildings VII*. Atlanta, GA: American Society of Heating Refrigeration and Air-Conditioning Engineers.

Hay, H.R. and Yellott, J.I. 1970. Naturally Air Conditioned Building. *Mechanical Engineering*, 92(1), pp 19-25.

Hay, H.R. and Yellott, J.I. 1968. International Aspects of Air Conditioning with Movable Insulation. *Solar Energy*, 12(1) pp 427-438.

Residential Energy Consumption Survey 2013, *Heating and Cooling No Longer Majority of U.S. Home Energy Use*, U.S. Energy Information Administration, Available from: www.eia.gov/todayinenergy/detail.cfm?id=10271&src=Consumption-b1# [28 January 2014].

Torcellini, P. A., Long, N., and Judkoff, R.D. 2004. Consumptive Water Use for U.S. Power Production. *ASHRAE Transactions: Research*, 110 (1), pp, 96-100.

Survey on the thermal comfort and occupant behaviour in the bedrooms of Japanese houses

Hikaru Imagawa¹, Hom B Rijal²

¹*Department of Environmental & Information Studies, Tokyo City University, Yokohama, Japan*

²*Department of Restoration Ecology & Built Environment, Tokyo City University, Yokohama, Japan*

¹g1131026@tcu.ac.jp

²rijal@tcu.ac.jp

Abstract

In order to know the thermal comfort of bedrooms, we have measured the air temperature and relative humidity in the 27 bedrooms of 11 houses. We have also conducted a thermal comfort survey, quality of sleep and occupant behaviour survey with the residents. Residents are highly satisfied with the thermal condition of the houses, using various thermal adjustments such as fans, clothing modifications, etc.

Keywords: Bedroom; Thermal comfort; Occupant behaviour; Clothing insulation; Fan usage

1. Introduction

Basically, Japan is rich in four seasons with hot summer and cold winter. So it is important to provide a suitable thermal environment for each season. However, by considering the regional and seasonal variation of Japan, achieving thermal comfort is not easy task. In addition, there are also complex environmental conditions due to the various factors including global warming, thermal radiation from concrete pavement and heat generated from electrical/electronic equipment which has a direct impact on the indoor climate.

Sleeping is one of the most important human behaviour in the domestic residence. However, sleep disorder are one of the key issues in recent years. This might be related to the various environmental changes which are mentioned above. Sleep disorders involve not just thermal comfort but also declining performance after waking up and general health deterioration.

In order to clarify the thermal comfort in bedrooms, we have measured the air temperature, relative humidity and global temperature in the 27 bedrooms of 11 houses. We have also conducted a thermal comfort survey, quality of sleep and occupant behaviour survey to the residents.

2. Field Study

The measurements were conducted in 11 houses in the Kanto region in Japan (Tokyo, Kanagawa and Chiba). The measurements were performed from August 10 to October 3, 2013. The indoor temperature and relative humidity were measured in 10 minute intervals at the height of 110 cm above the floor level of each bedroom. The outdoor temperature was obtained from the nearest meteorological station. The thermal comfort survey was conducted “before the occupants went to bed” and “after getting up” (Table 1). We have collected 1271 thermal comfort votes from 28 residents.

Table 1. Questionnaire for thermal comfort survey

No.	Thermal sensation	Thermal preference	Overall comfort	Sleep depth
1	Very cold	Much warmer	Very uncomfortable	Very light
2	Cold	A bit warmer	Uncomfortable	Light
3	Slightly cold	No change	Slightly uncomfortable	Slightly light
4	Neutral (neither cold nor hot)	A bit cooler	Slightly comfortable	Slightly deep
5	Slightly hot	Much cooler	Comfortable	Deep
6	Hot		Very comfortable	Very deep
7	Very hot			

3. Results and discussion

In this survey, the data was divided into two modes: the FR mode (Free running), CL mode (Cooling by air conditioning).

3.1 Outdoor and indoor air temperature

The mean outdoor air temperature during the survey was 27.7 °C in summer and 23.5 °C in autumn. The mean outdoor air temperature was 25.4 °C during the voting.

Figure 1 shows mean indoor air temperature during the voting in the bedroom. The mean indoor air temperature “before going to bed” was 27.5 °C in FR mode and 27.3 °C in CL mode. The mean indoor air temperature when “after waking up” was 27.9 °C in FR mode and 26.4 °C in CL mode. The results showed that the bedroom temperature of the CL mode was lower than the FR mode.

There are no significant differences of mean indoor air temperature by mode “before going to bed”, but there is a significant difference of mean indoor temperature by mode “after getting up/rising”. The results showed that residents used air conditioning during their sleep.

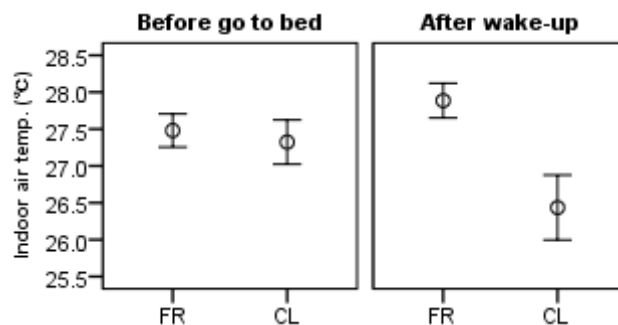

Figure 1 Mean indoor air temperature with 95% confidence interval

3.2 Evaluation of thermal comfort

3.2.1 Thermal sensations

Figure 2 shows distributions of thermal sensations, thermal preference and overall comfort. People generally voted “4 neutral” and “5 slightly warm” in FR mode and “4 neutral” in CL mode (Fig. 2(a)). There are many “3 no change”, “4 a bit cooler” votes in FR mode and “3 no change” votes in CL mode (Fig. 2 (b)). The results showed that most of votes are within the thermal comfort zone, and thus the sleeping environment is good. There are many “5 comfortable” and “4 slightly comfortable”, “3 slightly uncomfortable” votes in both modes. Even though people are feeling “neutral” and preferring “no change”, only a few people give the highest score for overall comfort.

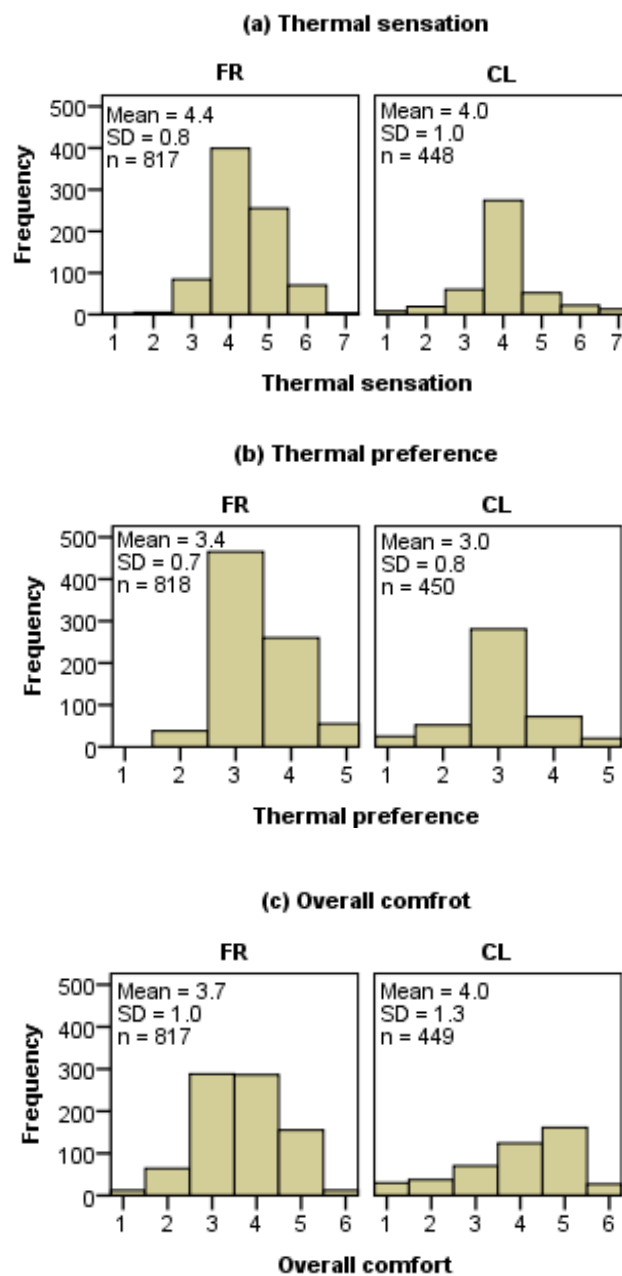

Figure 2 Distribution of thermal sensation, thermal preference and overall comfort

3.2.2 Relation between the thermal responses

Figure 3 shows the relation between the thermal preference and thermal sensation, overall comfort and thermal sensation, and overall comfort and thermal preference. On the whole, significance differences in FR mode are higher than CL mode. The reason might be that residents are considering the use of air conditioning (Fig. 3). The thermal preference and thermal sensation is correlated, and thus two scales are well-matched (Fig. 3(a)). When people felt “4 neutral” or “3 no change”, most residents preferred “comfortable”. However, there are only few votes for the category of “6 very comfortable” (Fig. 3(b)(c)).

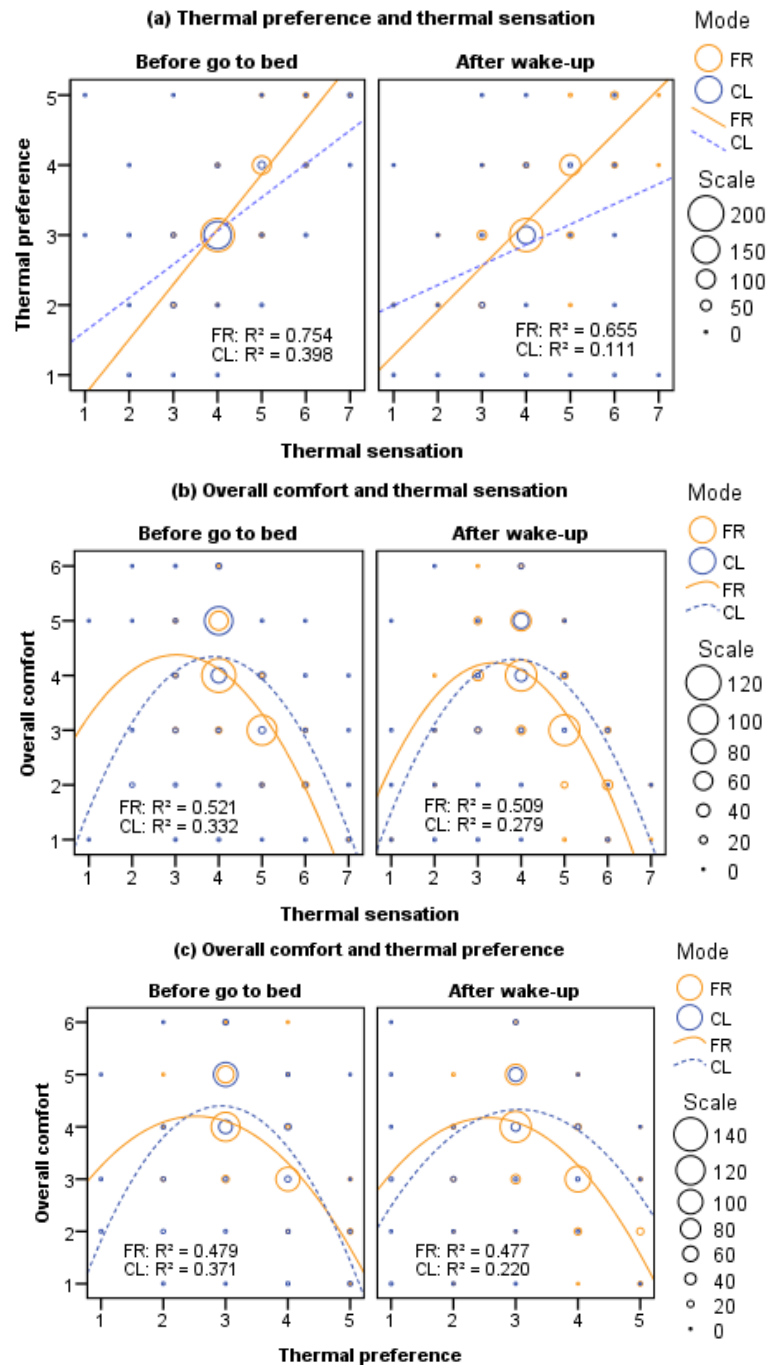

Figure 3 Relation between the thermal responses

3.2.3 Relation between the thermal responses and indoor air temperature

Figure 4 shows the relation between the thermal responses and indoor air temperature. The correlation coefficient of the FR mode is higher than the CL mode. In thermal sensation and thermal preference, the residents prefer “4 neutral” and “3 slightly cold”, “3 no change”, “4 a bit cooler” in FR mode. But in CL mode, the residents prefer only “4 neutral” and “3 no change”. The reason might be that residents are considering the use of air conditioning (Fig. 4). It seems that residents feel comfortable at 27 °C indoor air temperature “before going to bed” in the FR mode.

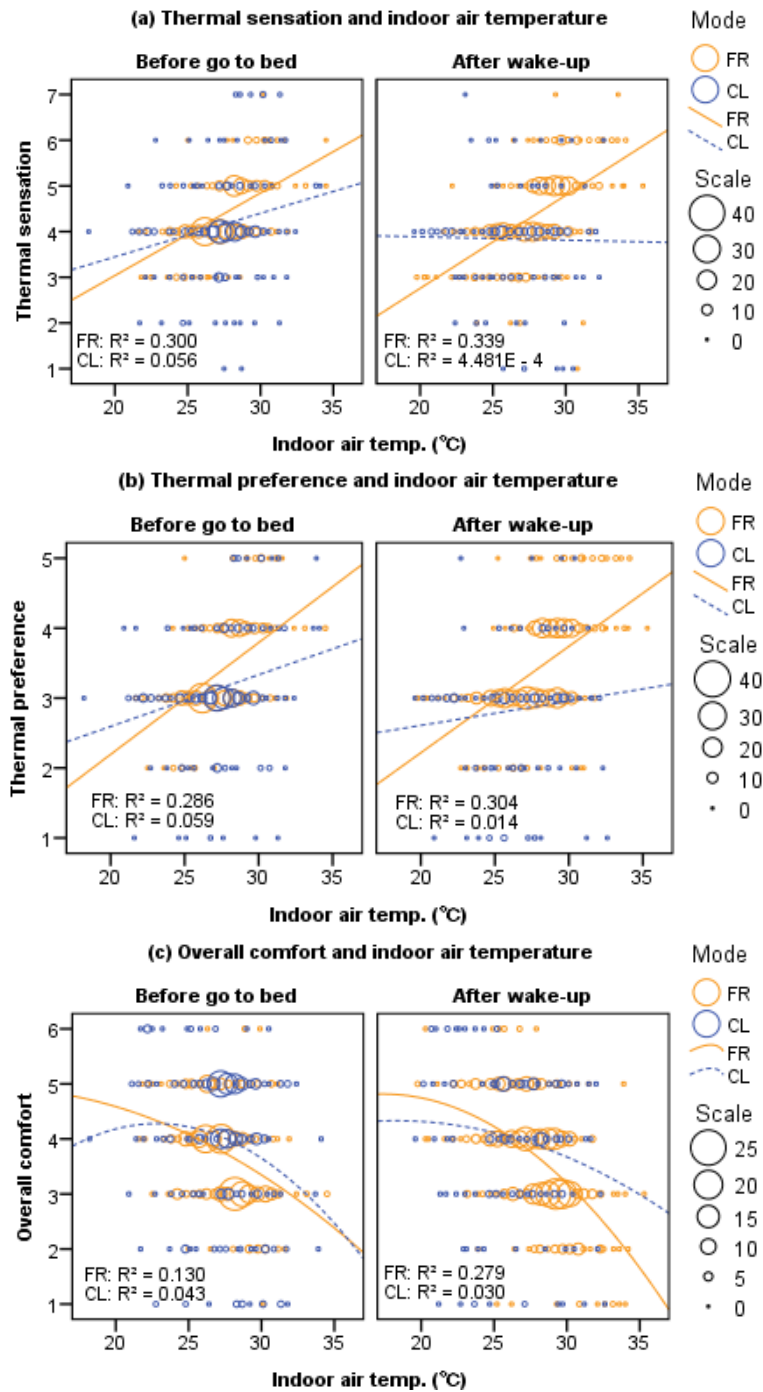

Figure 4 Relation between thermal responses and indoor air temperature

3.2.4 Prediction of comfort temperature by regression method

To predict the comfort temperature by the regression method, regression analysis of thermal sensation and indoor air temperature is conducted. The equation for CL mode is not statistically significant for “after waking up”.

Before going to bed,

$$\text{FR mode } C=0.181T_i-0.579 \text{ (n=354, r=0.55, p<0.001)} \quad (1)$$

$$\text{CL mode } C=0.095T_i-1.538 \text{ (n=283, r=0.24, p<0.001)} \quad (2)$$

After waking up,

$$\text{FR mode } C=0.204T_i-1.319 \text{ (n=465, r=0.58, p<0.001)} \quad (3)$$

C: Thermal sensation vote, T_i : Indoor air temperature (°C), n: Number of samples, r: Correlation coefficient, p: Significance level of the regression coefficient.

When the comfort temperature is predicted by substituting “4 neutral” in the equations (1) to (3), it would be 25.2 °C in the FR mode, 25.9 °C in the CL mode for “before going to bed”, and 26.1 °C in FR mode “after waking up”. However, these comfort temperatures are lower than the mean indoor temperature when voted “4 neutral” (Table 2). Thus, the comfort temperature is predicted by Griffiths’ method in the next section.

Table 2 Mean indoor air temperature when voting “4. neutral”

Items	Mode	n	T_{in} (°C)	SD(°C)
Before go to bed	FR	196	26.8	1.8
	CL	167	27.0	2.5
After wake-up	FR	203	27.0	2.1
	CL	107	26.1	3.0

n: Number of data, T_{in} : Mean indoor air temperature when residents vote “4 neutral” (°C), SD: Standard deviation (°C)

3.2.5 Prediction of comfort temperature by Griffiths’ method

The comfort temperature is predicted by the Griffiths’ method (Griffiths 1990, Nicol et al. 1994, Rijal et al. 2008).

$$T_c = T_i + (4 - C) / a \quad (4)$$

T_c : Comfort temperature, T_i : Indoor air temperature, C: Thermal sensation vote, a: Regression coefficient. In this research, a is assumed to be 0.5. The mean comfort temperatures by Griffiths’ method for “before going to bed” are 26.7 °C in FR mode and 27.0 °C in CL mode. As for “after waking up”, they are 27.2 °C in FR mode and 27.1 °C in CL mode respectively (Table 2). Since the mean comfort temperature of the Griffiths’ method is comparable to the mean indoor air temperature when voted neutral (Table 3).

From these results, it can be said that the comfort temperature according to Griffiths’ method is more appropriate than the regression method. The comfort temperature of this study was slightly lower than the recommended value of the Japanese government: 28 °C. The comfort temperature of this research is close to the previous research (Nishimura et al. 2011) (Table 4).

Table 3 Comfort temperature by Griffiths' method

Items	Mode	n	T_c (°C)	SD(°C)
Before go to bed	FR	354	26.7	1.8
	CL	280	27.0	2.9
After wake-up	FR	463	27.2	2.1
	CL	168	26.7	3.5

n: Number of data, T_c : Mean comfort temperature by Griffiths' method (°C), SD: Standard deviation (°C)

Table 4 Comfort temperature by Griffiths' method in previous research

Items	Mode	n	T_c (°C)	SD(°C)
Before go to bed	FR	436	27.1	2.4
	CL	584	27.2	2.4
After wake-up	FR	300	27.2	2.5
	CL	132	27.1	2.8

n: Number of data, T_c : Mean comfort temperature by Griffiths' method (°C), SD: Standard deviation (°C)

3.2.6 Relations between the thermal responses and hours of sleep

Figure 5(a) shows the relation between the thermal preference “after waking up” and hours of sleep. The correlation coefficient in CL mode is higher than in FR mode. This trend is different from relation between thermal responses and indoor air temperature. When people sleep more than 9 hours, they prefer “a bit warmer” or “much warmer”. This might be due to the use of air conditioning in long period of time. Fig. 5 (b) shows the relation between the overall comfort and hours of sleep. The overall comfort is highest, when people sleep 5 to 9 hours in FR mode.

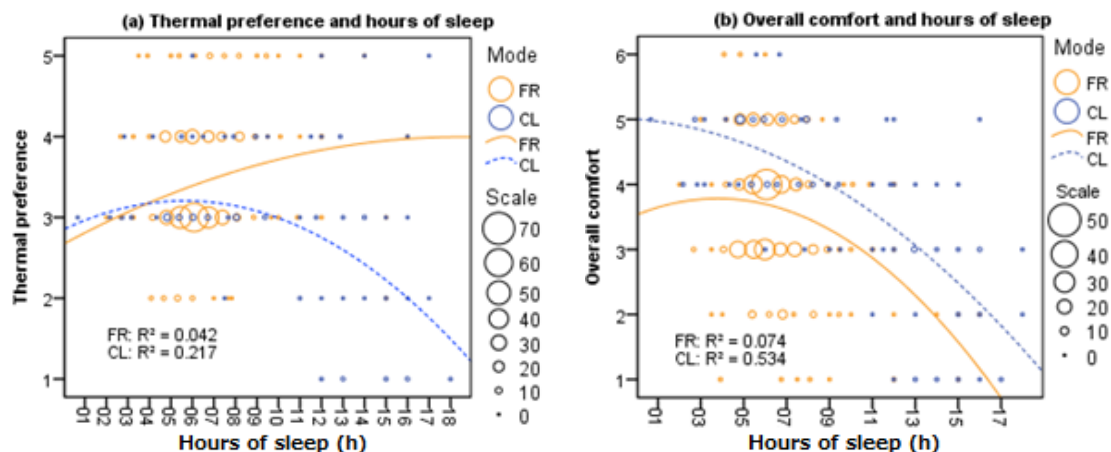

Figure 5 Relation between thermal responses and hours of sleep

3.2.7 Relation between the sleep depth and hours of sleep

Figure 6 shows the relation between the sleep depth and hours of sleep. The sleep depth is greatest when people sleep about 5~7 hours.

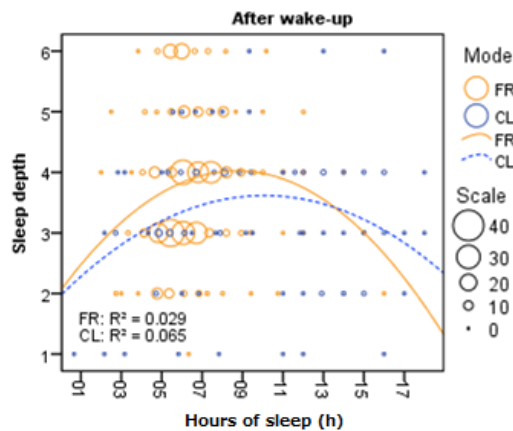

Figure 6 Relation between sleep depth and hours of sleep

3.3 Occupant behaviour

3.3.1 Cooling and fan usage

Table 4 shows the proportion of cooling and fan usage. The proportion of cooling usage is 61 % “before going to bed” and 30 % “after waking up” in summer. The proportion of fan usage is 51 % “before going to bed” and “after waking up” in summer. The cooling and fan usage is significantly decreased in the autumn. The results showed that people adjusted their sleeping environment by using various controls.

Table 4 Proportion of cooling and fan use

Items	Mode	Cooling		Fan usage	
		Summer	Autumn	Summer	Autumn
Before go to bed	Number of data	295	342	279	341
	Proportion (%)	61	30	51	22
After wake-up	Number of data	290	339	278	339
	Proportion (%)	30	24	51	18

3.3.2 Clothing insulation

The range of clothing insulation are 0.2 ~ 0.5 clo (Fig. 7). Most people were about 0.3 clo in this survey. The clothing insulation and indoor temperature is negatively correlated.

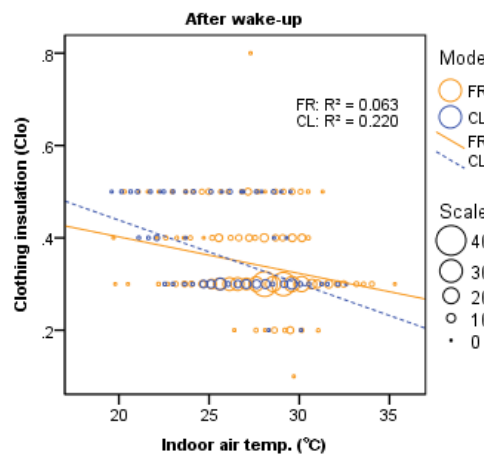

Figure 7 Relation between the clothing insulation and indoor air temperature

4. Conclusions

In this research, we conducted thermal measurements in the bedrooms and a thermal comfort survey of residents in the Kanto region of Japan. The following results were found:

1. The number of data of “neutral” vote was highest. The residents proved highly satisfied with the thermal environment of their bedrooms.
2. The comfort temperatures predicted by Griffiths’ method “before going to bed” are 26.7 ~ 27.2 °C.
3. The proportion of cooling and fan usage is significantly high in summer.
4. The clothing insulation and indoor temperature is negatively correlated.

References

1. Griffiths I.D. (1990), Thermal comfort in buildings with passive solar features: Field studies. Report to the Commission of the European Communities. EN3S-090 UK: University of Surrey Guildford.
2. Nicol F., Jany G.N., Sykes O., Humphreys M., Roaf S., Hancock M. (1994), A survey of thermal comfort in Pakistan toward new indoor temperature standards, Oxford Brookes University, Oxford England.
3. Rijal H.B., Tuohy P., Humphreys M.A., Nicol J.F., Samuel A., Raja I.A., Clarke J. (2008), Development of adaptive algorithms for the operation of windows, fans and doors to predict thermal comfort and energy use in Pakistani buildings. ASHRAE Transactions, 114 (2): 555-573.
4. Ministry of the Environment, Government of Japan (2005), Result of “CoolBiz” campaign, <http://www.env.go.jp/en/press/2005/1028a.html>,
5. Nishimura M., Rijal H.B. (2011), Investigation of the comfort temperature and quality of sleep in the bedrooms, Summaries of Technical Papers of Annual Meeting AIJ, pp. 31-32.

WINDSOR CONFERENCE 2014

COUNTING THE COST OF COMFORT

SESSION 2

Controlling Comfort

Invited Chairs: Hom Rijal and Madhavi Indraganti

Individual Thermal Control in the Workplace and Changes in Thermal Preferences in a Day: Norwegian Cellular vs. British Open Plan Layouts

Sally Salome Shahzad¹, John Brennan² and Dimitris Theodossopoulos³

1 Edinburgh School of Architecture and Landscape Architecture, Edinburgh College of Art, University of Edinburgh, UK, sshahzad@exseed.ed.ac.uk

2 & 3 Edinburgh School of Architecture and Landscape Architecture, Edinburgh College of Art, University of Edinburgh, UK

Abstract

This research suggests that the thermal preference of occupants is subject to change; hence, a particular thermal setting may not be able to constantly satisfy everyone. On the contrary, individual thermal control in the workplace is more likely to increase user comfort and satisfaction. This is examined through environmental measurements, comfort surveys and semi-structured interviews in two office layouts with high and low thermal control. Two Norwegian cellular plan offices that provide each user with control over a window, heating and cooling are compared with two British open plan offices with limited openable windows for users seated around the perimeter of the building. Complementary quantitative and qualitative methodologies and analysis techniques are applied with a particular emphasis on grounded theory and an innovative visual analysing technique. Overall, rather than setting an 'optimum temperature' in an endeavour to satisfy all, it is suggested that buildings provide a degree of flexibility to allow occupants to adjust their thermal environment according to their requirements.

Keywords: Thermal comfort, individual control, workplace, adaptive comfort, steady state theory

1 Introduction

This research is based on the challenge in the field of thermal comfort between the steady state and adaptive comfort theories. These two theories are followed by two separate approaches, the universal comfort zone and adaptive opportunity, respectively. This research challenges the view of the standard comfort zone and investigates the application of adaptive opportunity or thermal control. Therefore two office designs with high and low levels of thermal control are compared. The user satisfaction is compared between Norwegian cellular plan offices with high levels of thermal control and British open plan offices with limited thermal control. In addition, consistency concerning the preference of occupants for a steady thermal condition during the day is examined.

Hawkes states that 'in environmental design, prevention is better than cure' (Hawkes, 2002). Banham recommends including comfort and environmental factors in architecture (Banham, 1984, Bluysen, 2009). He contends that modern architecture is handed to specialists to provide comfort for occupants and that architects no longer consider environmental criteria in their design. His criticism is that building facades

have become more important than the quality of the indoor environment (Banham, 1984). Nicol et al. explain that architects have passed the responsibility for providing thermal comfort in their designed buildings to engineers (Nicol et al., 2012), while the building envelope and the design of thermal control for occupants have a significant influence on the thermal environment as well as user satisfaction.

Users' demands, such as thermal control, have played an important role in the history of the workplace. However, current office designs are moving away from addressing these demands, as organisational goals replace workers' rights (Van Meel et al, 2006) and centrally controlled thermal systems replace user control (Bordass et al., 1993, Roaf et al, 2004). The Workers' Council in Northern Europe is losing its influence (Van Meel et al, 2006) and Scandinavian countries are moving away from the design of the personal offices, which were based on users' demands (Axéll et al, 2005, Gadsjö, 2006). Duffy explains that office design is disconnected from the user, as it has 'little to do with what the man at his desk really needs' (Duffy, 1966). The future of applying users' demands in the workplace is under debate. Harris claims that in the future thermal control will not be necessary as flexibility will replace fixed workstations (Harris, 2006). In contrast, Katsikakis suggests that attracting a talented workforce will be the main concern for organisations, and therefore, providing a pleasant work environment based on users' demands will be essential (Katsikakis, 2006).

2 Steady State vs. Adaptive Comfort Theories

There is a challenge in the field of thermal comfort between the steady state and adaptive comfort theories. The steady state theory emerged after the invention of the refrigerator. Engineers managed to find an 'optimum temperature' to keep meat and food fresh for longer periods. Their success led them to apply the same principle (i.e. optimum temperature) to office buildings, where people work (Nicol et al, 2012). The decision-making and active role of the user as well as the context were overlooked (Nicol et al, 1973). This view considers thermal comfort as a product (Fanger, 1970). It aims to provide a steady thermal condition and present it to the occupants, who passively receive it, in an endeavour to satisfy over 80% of them (ASHRAE Standard 55, 2010). In contrast, the adaptive comfort theory is based on the adaptive nature of the man. The adaptive principle states 'If a change occurs such as to produce discomfort, people react in ways which tend to restore their comfort' (Nicol et al, 1973, Nicol et al, 2012).

The main approach of the steady state researchers is the universal or standard comfort zone. Although adaptive comfort researchers have also contributed to the field for naturally ventilated buildings (ASHRAE, 2004, CEN, 2005, Nicol et al, 2005, Bluysen, 2009), their main approach is the adaptive opportunity. This is mainly 'an attribute of the building' (Baker et al, 1995) that allows people to 'take advantage of the actual and potential variations in room temperature' (Humphreys, 1996, Baker et al, 1995). The adaptive opportunity is about the building adjusting its thermal environment to meet the needs of occupants (Baker et al, 1995). Melikov explains that 'the heating, ventilation and air conditioning (HVAC) of buildings today is designed to provide a uniform room environment. However, large individual differences exist between occupants in regard to physiological and psychological response ... Environmental conditions acceptable for most occupants in rooms may be achieved by providing each occupant with the possibility to generate and control his/her own preferred microenvironment' (Melikov, 2004). Arens reports the relationship between occupants' individual thermal control and 'acceptance of their state' (Arens et al,

2010). Kroner reports high user productivity when individual thermal control is applied (Kroner, 2006).

3 Thermal Control in British Open Plan vs. Norwegian Cellular Plan Offices

The history of the workplace shows users' demands to access thermal control, such as the ability to adjust heating and cooling as well as an openable window. The latter allows an outside view, natural light and ventilation. After World War Two, Scandinavia and Anglo-Saxon countries followed two separate paths in the office design, albeit workers in both places had similar demands (Van Meel, 2000). The 'social democratic office' in Northern Europe and Scandinavia was more concerned with providing a pleasant environment rather than higher salaries and mass production concepts (Myerson, 2008, Forty, 1986). The Workers' Council in Northern Europe played an important role in protecting workers' rights. As a result, Norwegian offices were designed based on users' demands and workers' rights (Van Meel, 2000). Duffy explains that in Northern Europe, 'when users have power the provision of windows and close proximity to windows for everyone becomes tremendously important' (Duffy, 1992). Thus, personal offices with individual control over the thermal environment were provided for each occupant in Norway.

In contrast, the British office design was business oriented and based on efficiency and communication. Although British employees had similar demands to the Scandinavian workers regarding the quality of the indoor environment, they were overruled by the opposition of the British employers. Therefore open plan offices with limited thermal control for occupants were designed (Van Meel, 2000). The managerial and mass production concepts (Hookway, 2009) as well as technological advances, such as telephones and typewriters (Marmot et al, 2000), were the foundation of the open plan office. Lee and Brand explain that the Anglo-Saxon open plan layout was introduced as a flexible solution to many of the historic and contemporary challenges (Lee et al, 2005). Laing describes the British office as 'a self-regulating structural grid within which working groups grow and change' (Laing, 2006). The invention of air conditioning (i.e. 1930s) and florescent lights (i.e. 1940s) allowed the possibility of deep open plan offices with no need for natural light and ventilation (Laing, 2006). Duffy explains that in an open plan office, 'desks and equipment are arranged in ordered rows. Such offices are often very large, as staff work far from the windows, artificial light and ventilation are required' (Duffy, 1966). He indicates that users did not find this kind of office popular due to the unfriendly classroom set up, distractions and lack of individual environmental control (Duffy, 1992).

The Anglo-Saxon open plan offices are based on standardising the layout (Laing, 2006) as well as providing a uniform and standard thermal environment (Nicol et al, 2012). The main thermal system is centrally controlled to ensure the indoor air quality. For instance, in a naturally ventilated office, occupants may not open the windows in the winter, which increases the carbon dioxide level. Therefore, a centrally controlled system is required. In this system, thermal control is provided as a secondary option so that if occupants are uncomfortable they have the ability to adjust the thermal environment (Bordass et al, 1993). Hawkes explains that the manual control is only for 'fine-tuning' in case of a system failure (Hawkes, 2002). In contrast, in Scandinavia individual thermal control is the main source of adjusting the thermal environment. In order to ensure the temperature and indoor air quality are within the acceptable range, centrally controlled mechanical ventilation with adequate air exchange operates in the background (Arbeidstilsynet, 2003).

4 Methodologies

Although the traditional approach in thermal comfort is through quantitative methodologies, recently the application of qualitative methodologies is encouraged (Hitchings, 2009). In this research, a combination of quantitative and qualitative methodologies is applied with a particular emphasis on grounded theory. The latter is a cyclic process of research planning, collecting and analysing data (Glaser et al, 1967). Several pilot studies were examined to refine the research plan. Measurements of the thermal environment were applied to record the building performance together with simultaneous survey questionnaires to record the view of occupants concerning the thermal environment. Each workstation was investigated three times a day: morning, early and late afternoon. The ASHRAE seven-point scale thermal sensation (e.g. slightly cool, neutral and slightly warm), comfort and satisfaction as well as thermal intention (e.g. slightly cooler, no change and slightly warmer) comprised the main factors. These traditional methods were reinforced with semi-structured interviews to further investigate the application of thermal control. Overall, four case study buildings were investigated and 103 respondents participated in this research, which included approximately thirty respondents in each of the four buildings. Each participant responded to the survey questionnaire three times a day. Quantitative and qualitative analysis techniques were applied on the collected data. An innovative visual recording technique was introduced to analyse the information according to the context and meaning.

5 Building Performance

In this research, two British open plan offices with limited thermal control are compared with two Norwegian cellular plan offices with high levels of thermal control. The building performance of all four case study buildings are analysed regarding the ventilation system, carbon dioxide level, energy and thermal performance.

5.1 Ventilation System

In the cellular plan offices, air conditioning is working in the background. However, the main system provides each occupant with access to an openable window, blinds, door and the ability to adjust the cooling or heating. In contrast, in the open plan offices, the centrally controlled mechanical system is the main ventilation system, while limited occupants seated around the perimeter of the building can access openable windows and blinds, as presented in Figure 1 and Figure 2. In the Norwegian offices, each occupant is expected to adjust the heating through the available individual control systems to find their own comfort. In contrast, in the British offices, the centrally controlled thermal system presents comfort to the occupants and limited openable windows are provided in case occupants are uncomfortable.

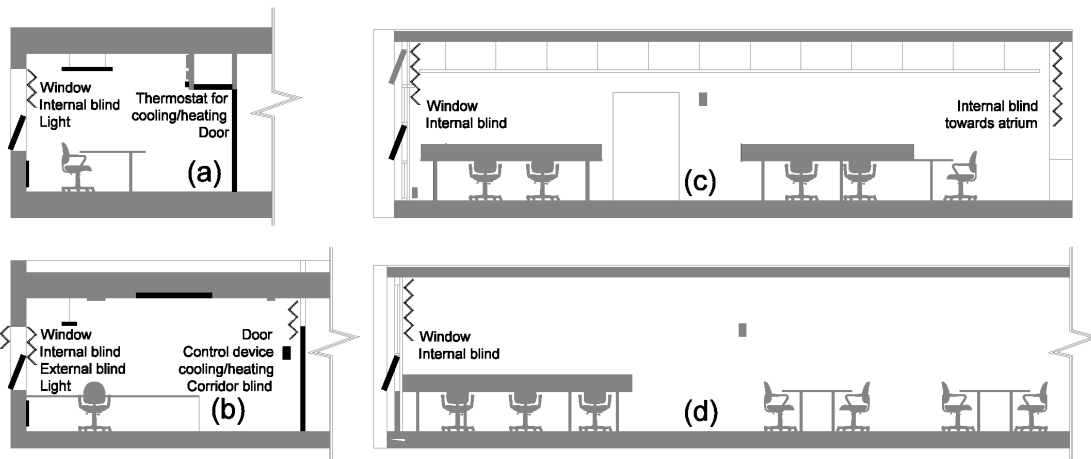

Figure 1: Sections, individual environmental control in (a) and (b): Norwegian cellular plan offices and (c) and (d): British open plan offices

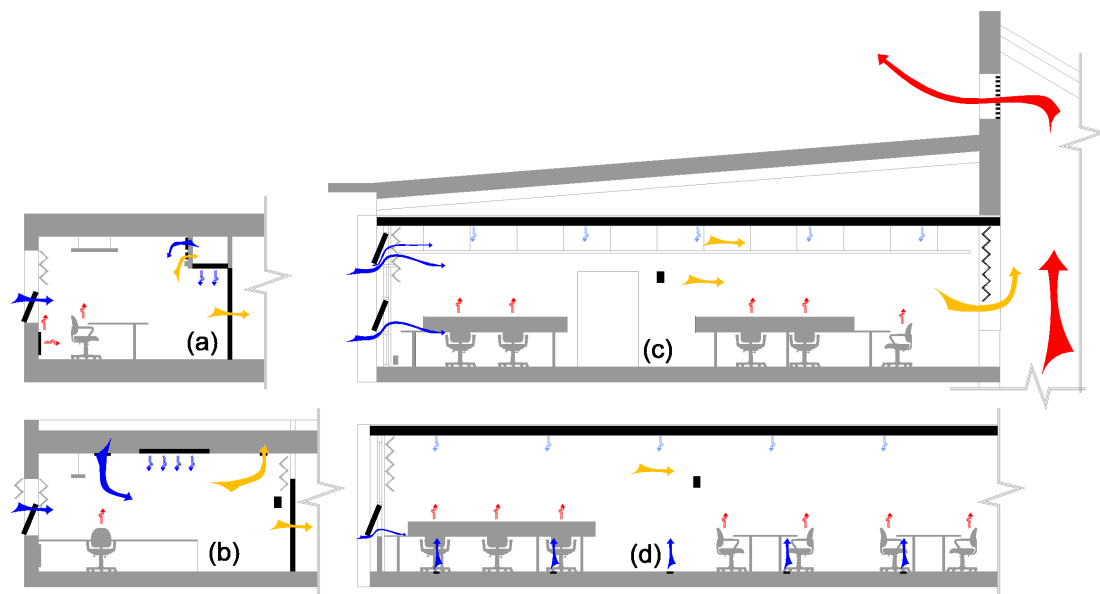

Figure 2: Sections, summer day ventilation in in (a) and (b): Norwegian cellular plan offices and (c) and (d): British open plan offices

5.2 Carbon Dioxide Level

The comparison of the carbon dioxide level between the case study buildings shows that the air quality of all four buildings falls into the acceptable range, as presented in Figure 3.

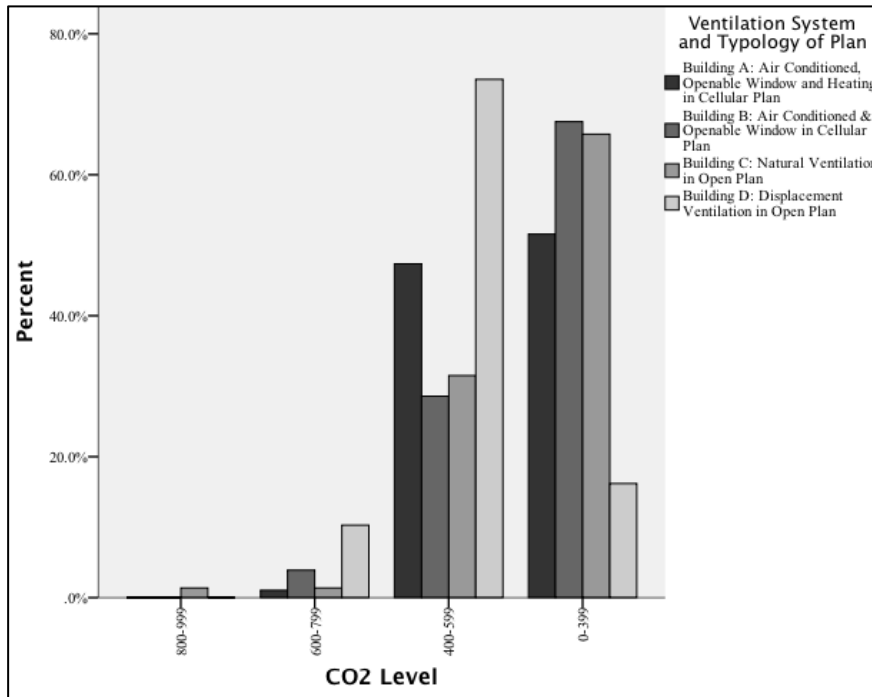

Figure 3: SPSS frequency bar chart, comparing the CO₂ levels between the four case study buildings

5.3 Energy Consumption

The energy consumption analysis shows that except for one of the Norwegian cellular plan offices, all the other buildings are within the acceptable range of the CIBSE benchmark (CIBSE, 2003), as presented in Figure 4.

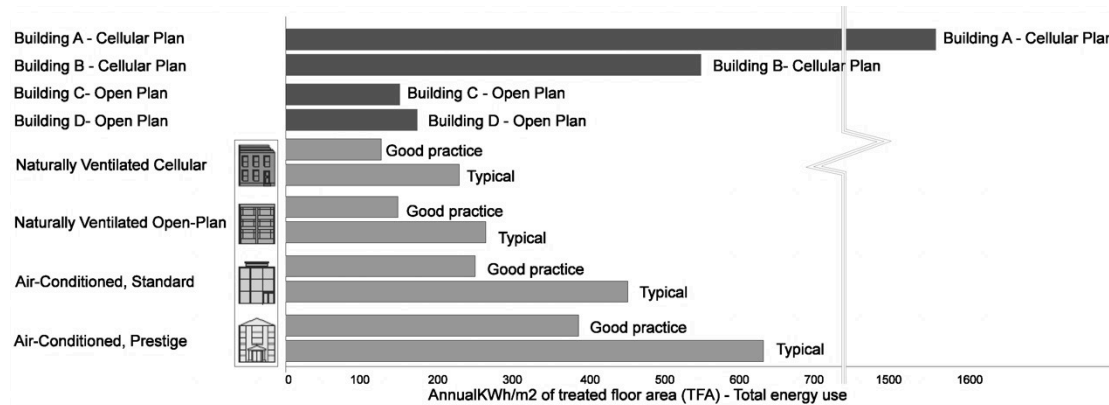

Figure 4: Energy consumption of the four case study buildings kWh/m² per year

5.4 Thermal Comfort Predictions

The thermal measurements of every workstation are analysed using the ASHRAE Thermal Comfort Tool (Huizenga, 2011), which is based on the ASHRAE Standard 55-2010. The adaptive comfort prediction model shows that all four buildings are expected to have comfortable thermal environments, as presented in Figure 5.

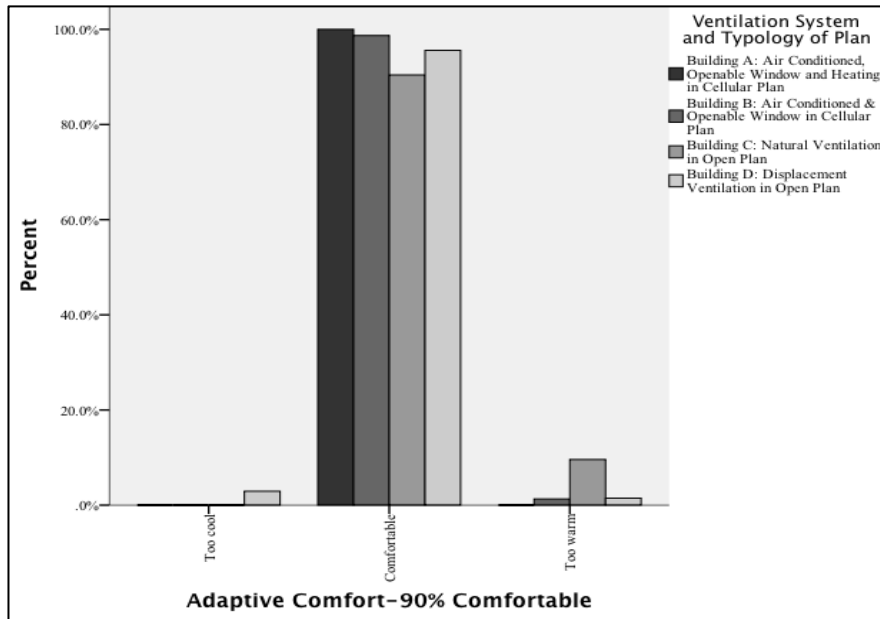

Figure 5: SPSS bar chart, frequency analysis of the ASHRAE adaptive model in the four buildings

Overall, the building performance analysis indicates that all four case study buildings provide high standards of indoor thermal environment. They are within the benchmark and expected to provide comfortable thermal environments. Therefore the difference in the comfort and satisfaction levels of the users is less likely to be related to the quality of the thermal environment, which is confirmed by the follow up interviews.

6 Steady vs. Dynamic Thermal Preference

The consistency of overall thermal preference of each occupant throughout the day is examined in this section. An innovative visual recording technique is introduced to analyse the data qualitatively according to the context and meaning.

6.1 Visual Recording Technique

Thermal comfort is often researched by engineers (Meir et al, 2009), who apply mainly quantitative analysis methods. Nicol et al explain that ‘Architects have gradually passed responsibility for building performance to service engineers, who are largely trained to see comfort as a “product”, designed using simplistic comfort models’ (Nicol et al, 2012). The research outcomes of engineers are based on ‘mathematical language and logic’ (Gaucherel et al, 2011), which may not appear so convenient to architects. In order to encourage architects to contribute to the field of thermal comfort, the use of a familiar language is useful. ‘Visual tools are commonly used in the field of architecture to apply information on plans and sections. They add a different value and perspective by putting together different information regarding a specific aspect in a visual way’ (Shahzad, 2013). In addition, the traditional quantitative analysis of thermal comfort is useful to examine the physical reactions, to refine the standard comfort zone and to compare a variable between two buildings. However, it overlooks the context and meaning, which are highlighted in this research. Shahzad explains that ‘the interpretation of the connection between information through a quantitative approach could drive to a misjudgement’ (Shahzad, 2013).

In this research, careful consideration is given to keep the connection between the collected data and the context. Therefore, a qualitative analysis technique is introduced to analyse the data by means of contextual information, including time, thermal sensation and intention, as presented in Figure 6. This pictogram is a top view of a seated person. The colours inside the ellipses symbolising the person's body, indicate the person's reported survey at the time of the measurements at their particular workstation. The colour of the person's head shows their thermal intention, which is their desire to change the temperature. The space between the arms indicates the thermal sensation of the person. The overall thermal preference of an individual is a combination of the thermal sensation and thermal intention of that person. Green shows a neutral thermal sensation or no change in the temperature, while red and blue indicate warm and cold sensations, respectively. Figure 7 shows a sample of the information on the plans of the two buildings.

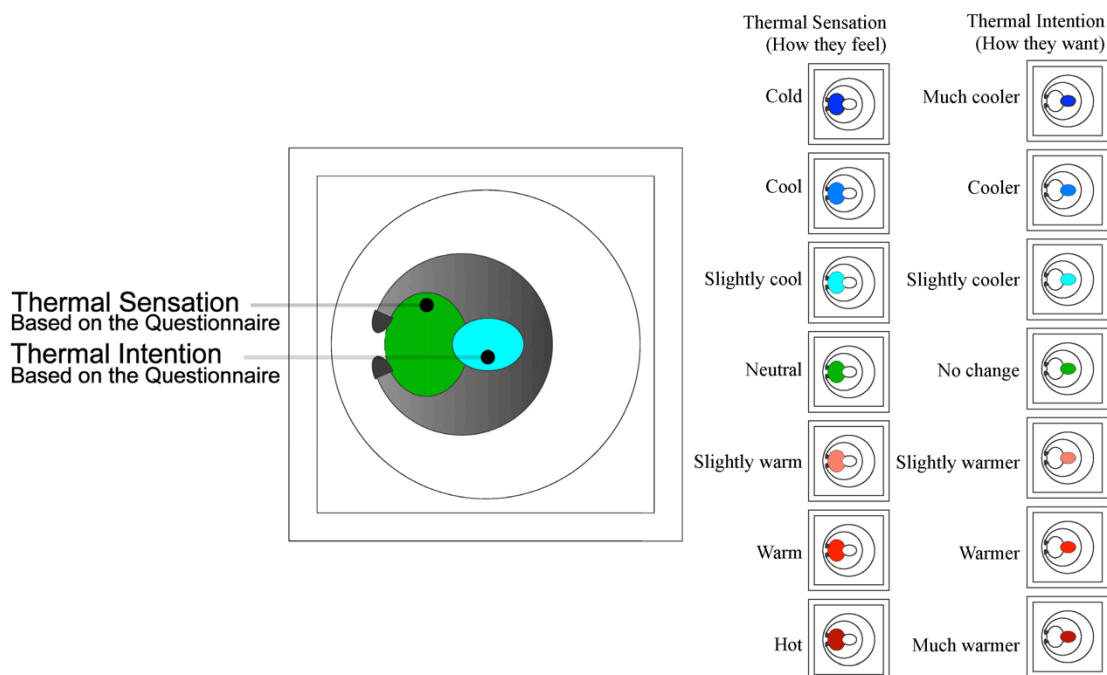

Figure 6: Visual recording technique: Thermal sensation and thermal intention of a respondent

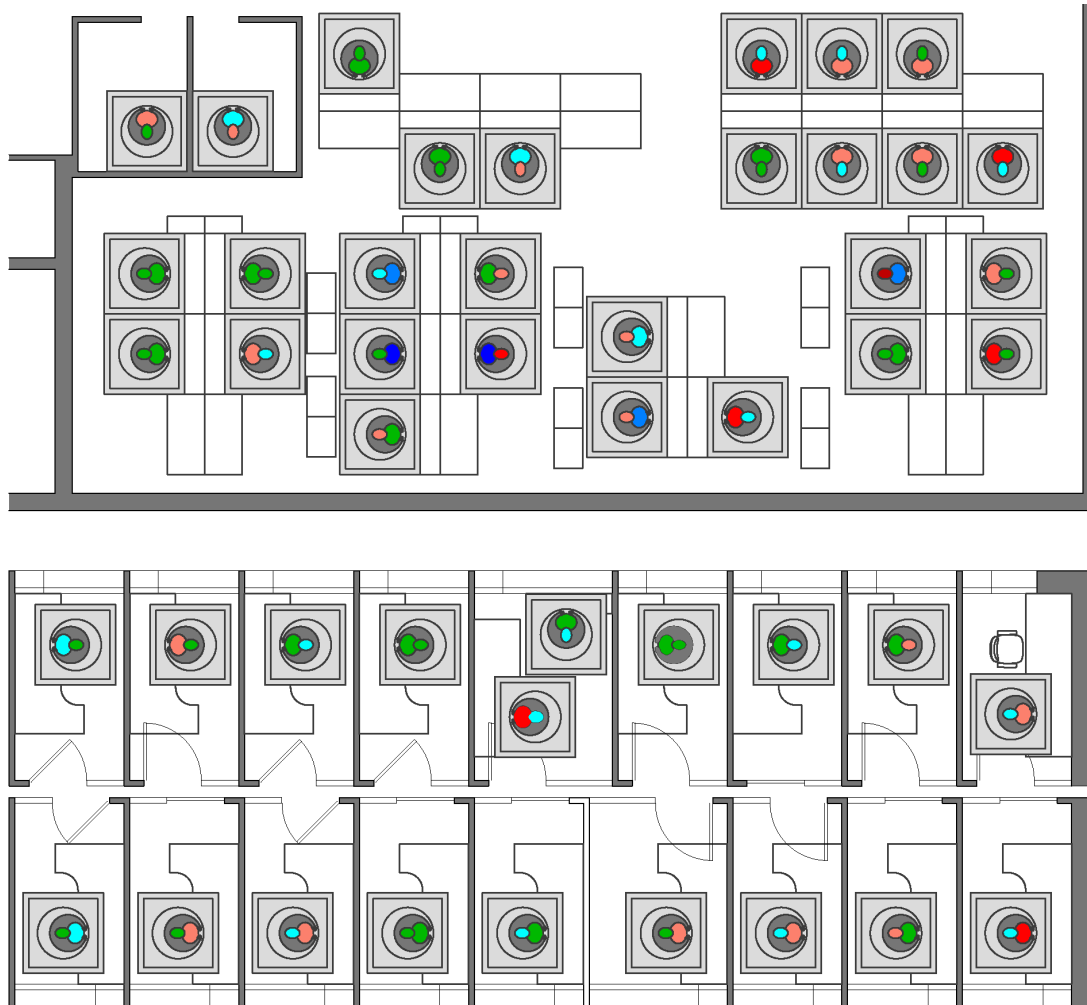

Figure 7: A sample of the visual recording technique, morning recordings of buildings B and D

6.2 Consistency of Thermal Preference

Figure 12 examines the consistency of the thermal preference of the occupants throughout the day. The morning, early and late afternoon recordings for each individual are extracted from the plan and compared. Figure 8 shows how to read the information in Figure 12. Although the presented individual in Figure 8 feels neutral during the day, their thermal intention changes from 'slightly warmer' in the morning and early afternoon to 'no change' in the late afternoon. In this case, the overall thermal preference of the person changes from 'slightly warm' in the morning and early afternoon to 'neutral' in the late afternoon. Therefore, the thermal preference of this occupant is 'not consistent', which is demonstrated by a red cross in the pictogram. This indicates that the person is comfortable feeling 'slightly warm' at the beginning and midday, while 'neutral' closer to the end of the working day, rather than a consistent thermal preference throughout the day. In order to read the information in Figure 12, three more samples are presented. The samples in Figure 9 and Figure 10 show consistency in the thermal preference, while Figure 11 demonstrates inconsistency in the thermal preference of an individual during the day.

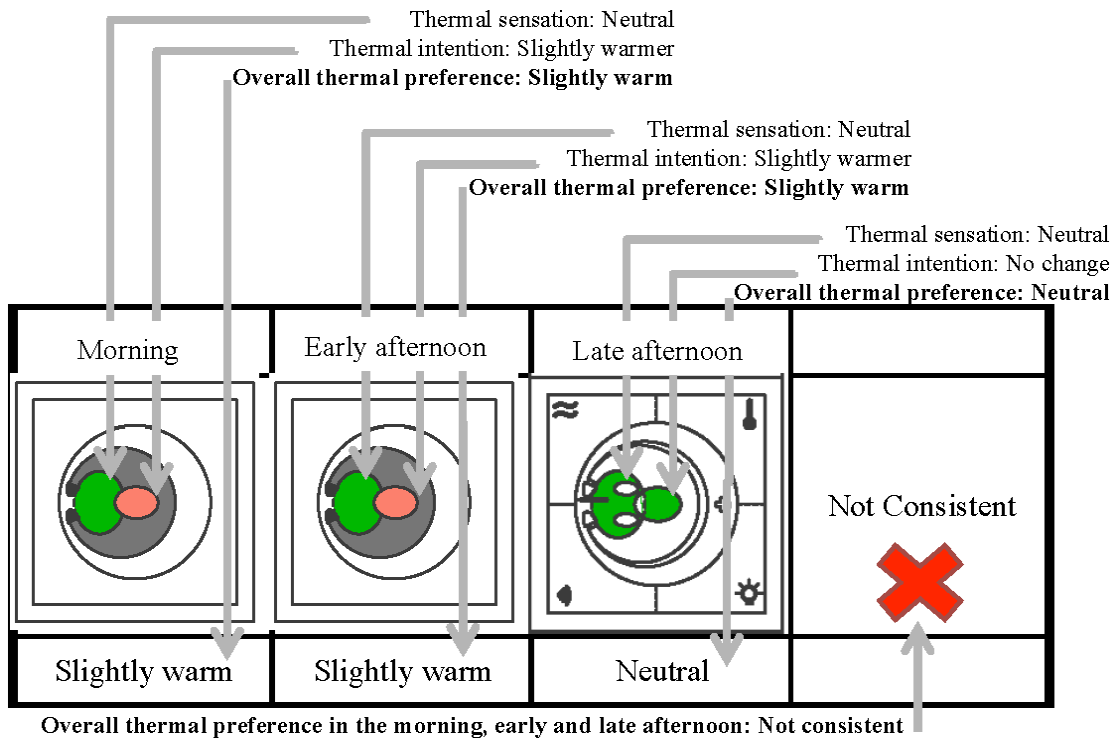

Figure 8: Overall thermal preference is inconsistent and it changes from 'slightly warm' in the morning and early afternoon to 'neutral' in the late afternoon (all based on survey questionnaires)

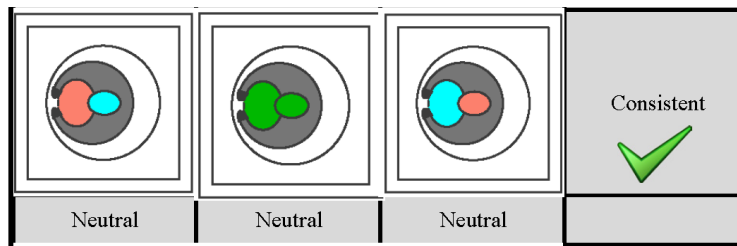

Figure 9: Overall thermal preference is consistently 'neutral' in the morning, early and late afternoon

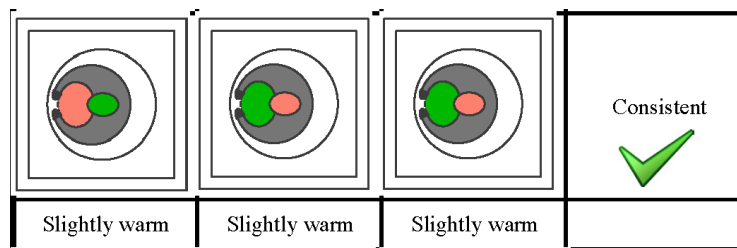

Figure 10: Overall thermal preference is consistently 'slightly warm' during the day

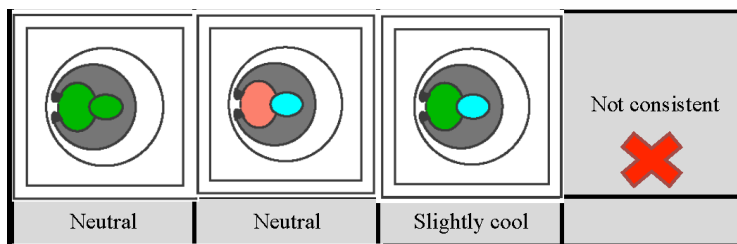

Figure 11: Overall thermal preference is inconsistent, changing from 'neutral' in the morning and early afternoon to 'slightly cool' in the late afternoon

Building B				Building D			
Does the occupant want to feel neutral? during a day: morning, early and late afternoon?			Consistency in thermal preference	Does the occupant want to feel neutral? during a day: morning, early and late afternoon?			Consistency in thermal preference
Morning	Early afternoon	Late afternoon		Morning	Early afternoon	Late afternoon	
			Not consistent ✗				Not Consistent at all ✗ ✗
Slightly warm	Neutral	Neutral		Slightly cool	Neutral	Slightly warm	
			Consistent ✓				Not Consistent at all ✗ ✗
Neutral	Neutral	Neutral		Cold	Slightly warm		
			Consistent ✓				Consistent ✓
Neutral	Neutral	Neutral		Slightly warm	Slightly warm	Slightly warm	
			Consistent ✓				Not consistent ✗
Neutral	Neutral	Neutral		Neutral	Slightly warm	Neutral	
			Not consistent ✗				Not consistent ✗
Slightly warm	Neutral	Neutral		Slightly warm	Neutral	Neutral	
			Not consistent ✗				Not consistent ✗
Slightly warm	Neutral	Neutral		Neutral	Neutral	Slightly cool	
			Not consistent ✗				Not consistent ✗
Slightly cool	Neutral	Neutral			Slightly warm	Neutral	
			Not Consistent at all ✗ ✗				Not consistent ✗
Neutral	Slightly cool	Slightly warm		Slightly warm	Neutral	Neutral	
			Not consistent ✗				Consistent ✓
Neutral	Neutral	Slightly cool		Neutral	Neutral	Neutral	
			Not consistent ✗				Consistent ✓
Slightly warm	Neutral			Neutral	Neutral	Neutral	

Figure 12: A sample of the visual recording analysis of consistency in overall thermal preference of each participant in the morning, early and late afternoon

Consistency of Thermal Preference of Occupants During the day		Building A	Building B	Building C	Building D	All 4 Buildings
Consistant	✓	21	6	10	9	46
Not consistant	✗	9	16	10	9	44
Not consistant at all	✗✗	0	4	4	5	13

Figure 13: Consistency of thermal preference of occupants throughout the day

Figure 13 shows the number of individuals with consistent and inconsistent thermal preference in the four case study buildings. 46 out of 103 participants in the four case study buildings (i.e. 45%) have consistency in their thermal preferences in the morning, early and late afternoon. However, in 57 cases (i.e. 42%) there is limited inconsistency in the thermal preferences of individuals during the day. 13 individuals (i.e. 13%) have extreme preferences during the day. Overall, more than half of the participants in this study (i.e. 55%) have different thermal preferences during the day and their desired set point of temperature changes.

7 Individual Thermal Control

In this section, the two British open plan offices are compared to the two Norwegian cellular plan offices regarding occupants' satisfaction and comfort. Quantitative analysis methods are applied.

7.1 Quantitative Analysis

Quantitative analysis using the SPSS linear regression analysis is applied to compare the satisfaction and comfort in the four case study buildings. The P value of both variables (i.e. 0.000) is less than 0.05, which suggests a significant relationship between each variable (i.e. satisfaction and comfort) and type of plan (i.e. open and cellular plan offices). The SPSS frequency analysis shows that the satisfaction levels of satisfied and very satisfied respondents in the two open plan offices are close (i.e. 30%), and that the satisfaction levels in the two cellular plan offices are also close (i.e. 60%). It also indicates that the comfort levels of comfortable and very comfortable respondents in the two open plan offices are close (i.e. above 55%), and the satisfaction levels in the two cellular plan offices are also close (i.e. above 75%). The analysis of satisfaction and comfort are presented in Figure 14 and Figure 15, respectively. The darker lines represent the two Norwegian cellular plan offices, while the lighter lines indicate the two British open plan offices.

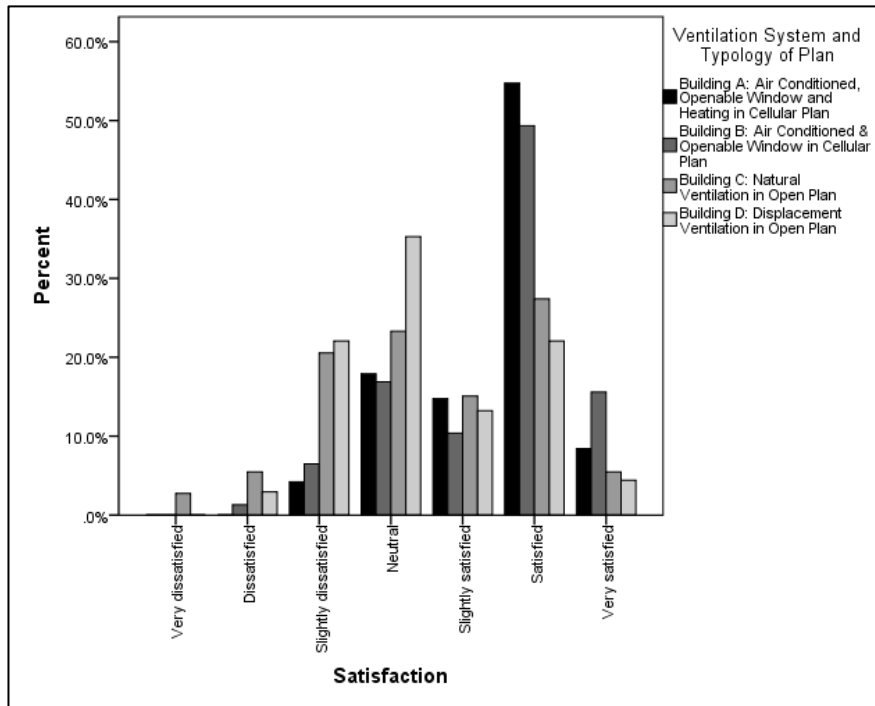

Figure 14: Satisfaction level in the four case study buildings

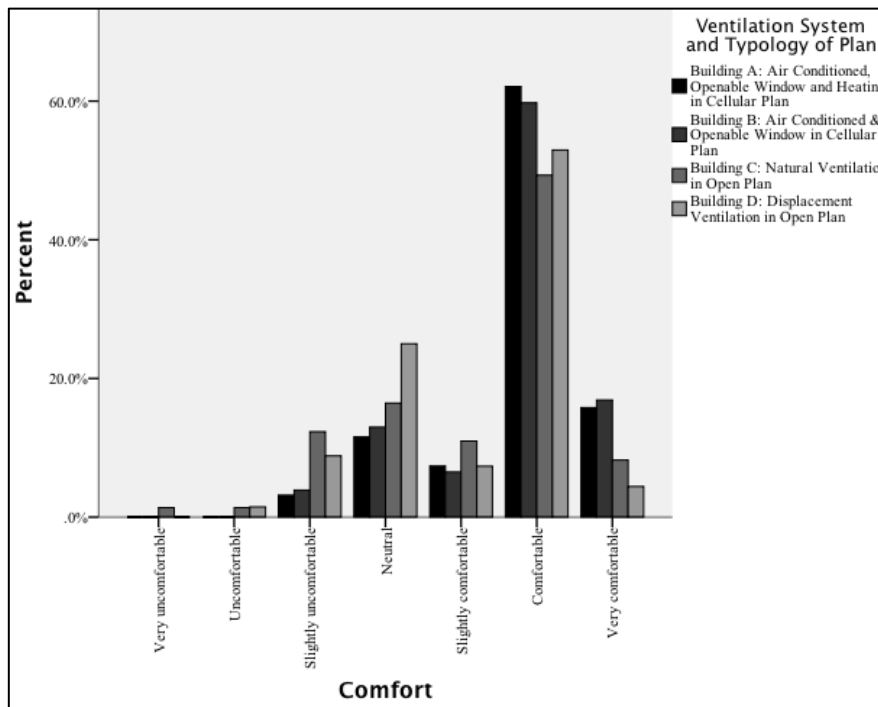

Figure 15: Comfort level in the four case study buildings

Overall the results suggest that, respectively, satisfaction and comfort are 30% and 20% higher in the cellular plan compared to the open plan offices.

8 Discussion

The results of this research demonstrate the inconsistency in the thermal preference of individuals throughout the day. The results suggest that the thermal preference of a particular individual is subject to change. Over half of the respondents did not have a steady thermal preference during the day, preferring different thermal settings at

different times. This suggests that an individual is more likely to expect different thermal conditions at different times in order to feel comfortable. Therefore a particular thermal setting, such as in a centrally controlled thermal system, is less likely to satisfy a particular individual at all times. Hence, when a particular thermal setting from the standard comfort zone is applied to the office constantly, there is no guarantee that every individual occupant is constantly comfortable. This poses a difficulty to the steady state theory and the concept of comfort zone, as it suggests that the thermal preference of each individual is dynamic rather than fixed. This finding is in contrast to the view of the steady state thermal setting that constantly satisfies over 80% of the occupants. It suggests that no matter how much the standard comfort zone is refined, it is less likely to be applied to real world situations because thermal comfort is dynamic and a fixed temperature is less likely to provide thermal comfort.

The other finding in this research suggests that the occupants of the two Norwegian cellular plan offices with higher levels of individual thermal control are more satisfied and comfortable compared to those in the two British open plan offices with limited thermal control. This is in line with workers' demands in the 1970s regarding openable windows and individual thermal control (Van Meel, 2000). The satisfaction and comfort levels of the Norwegian offices are respectively 30% and 20% higher than the British offices. The building performance and thermal environment of the four buildings was within the acceptable range and the major difference between these two offices is the availability of thermal control for the users. This suggests that the availability of thermal control increases user satisfaction and comfort. In addition, the interview results confirm this finding, as the Norwegian respondents explained the significant influence of individual thermal control in their personal offices on their satisfaction and comfort. In contrast, the British respondents complained about the lack of thermal control and its undesirable influence on their satisfaction and comfort. The majority of them had to tolerate the situation when they found the thermal environment uncomfortable. Sometimes they found it so difficult to cope with the thermal condition at their workstation that they put on inconvenient clothing layers, such as a sleeping bag, or they stayed at home. In addition, this finding is in line with other research in the field, which indicates that thermal control increases satisfaction (Wagner et al, 2007, Brager et al, 2009, Newsham et al, 2009) and comfort (Bordass et al, 1993).

Although Nicol and Humphreys do not agree with all aspects of the thermal standards, they explain that 'thermal comfort standards are required to help building designers to provide an indoor climate that building occupants will find thermally comfortable' (Humphreys et al, 2002). The further the indoor thermal conditions are from the standard comfort zone, the more likely it is that occupants will be uncomfortable (Nicol et al, 2005). Although the knowledge of the standard comfort zone is useful at the design level, this research suggests that a thermal condition that is set based on the standards does not guarantee thermal comfort. Nicol and Humphreys suggest that workplace design should focus on thermal control systems and their operation rather than on providing an optimum thermal environment (Nicol et al, 1973).

9 Conclusion

This research suggests that rather than providing a uniform thermal condition according to the standard 'comfort zone', office buildings are recommended to provide a degree of flexibility to allow users to find their own comfort by adjusting their thermal environment according to their immediate requirements. It is also

proposed that thermal comfort is dynamic, as the thermal preference of the occupants changes at different times.

The Scandinavian cellular plan offices presented in this research are good practice examples of providing individual thermal control for each occupant through the architectural design and office layout. The architectural design of the personal office provides each occupant with an openable window for an outside view, natural light and ventilation, in addition to blinds, a door and a thermostat to adjust the temperature. The Scandinavian cellular office layout respects individual differences and allows all users to adjust the thermal environment based on their individual requirements without interfering with other occupants' thermal settings. In the Norwegian case study buildings, occupants find their own comfort by adjusting the thermal environment, while in the British case studies comfort is offered through a centrally controlled thermal system with additional adaptive opportunity for fine-tuning. The individual thermal control is the key factor in higher user satisfaction and comfort in the Norwegian cellular plan offices compared to the British open plan offices in this research.

Two main difficulties limit this research and its findings: an obstacle regarding this particular research and a complexity that is associated with the field studies of thermal comfort. Respectively, accessing the buildings and the complexities of the context are the main constraints in this research, which lead to a difficulty in generalising the findings.

10 Acknowledgement

The authors would like to acknowledge Donald Canavan, Brian Stewart, Ingeborg Hovik, Cristina Gonzalez-Longo, Ola Uduku, Knut Inge Fostervold, Hendricus De Jonge, Kay From, Winston Smith, Steve Keil, Claire Lessells, Michael Duncan, Farah and Daryoush Shahzad as well as the management and occupants of the four buildings.

References

- ARBEIDSTILSYNET 2003. *Control and Guidance on Working: Veiledning om klima og luftkvalitet på arbeidsplassen - fulltekst*. In: ARBEIDSTILSYNET (ed.). Norway.
- ARENS, E., HUMPHREYS, M. A., DE DEAR, R. & ZHANG, H. 2010. *Are 'Class A' Temperature Requirements Realistic or Desirable?* Building and Environment, 45, 4-10.
- ASHRAE 2004. *ASHRAE Standard 55-2004*. USA: American Society of Heating, Refrigerating and Air-Conditioning Engineers.
- ASHRAE 2010. *ASHRAE Standard 55*. In: COOPER & W., K. (eds.) *Thermal Environmental Conditions for Human Occupancy*. Atlanta: American Society of Heating, Refrigerating and Air-Conditioning Engineers.
- AXÉLL, C. & WARNANDER, A. 2005. *How to Create Optimal Office Solutions*. MSc, KTH University.
- BAKER, N. & STANDEVEN, M. 1995. *A Behavioural Approach to Thermal Comfort Assessment*. International Journal of Solar Energy, 19, 21-35.
- BANHAM, R. 1984. *The Architecture of Well-Tempered Environment*, Chicago and London, The University of Chicago Press and The Architectural Press Ltd.
- BLUYSSSEN, P. M. 2009. *The indoor environment handbook : how to make buildings healthy and comfortable*, London, Earthscan.

- BORDASS, B., BROMLEY, K. & LEAMAN, A. 1993. *User and Occupant Controls in Office Buildings*. Building Use Studies.
- BRAGER, G. S. & BAKER, L. 2009. *Occupant Satisfaction in Mixed-Mode Buildings*. Building Research and Information, 37, 369-380.
- CEN 2005. *European Standard, CEN prEN 15251. Criteria for the Indoor Environment Including Thermal, Indoor Air Quality, Light and Noise*. Brussels: CEN.
- CIBSE 2003. *Energy Consumption Guide 19: Energy Use in Offices. Best Practice Programme*. The Chartered Institution of Building Services Engineers.
- DUFFY, F. 1966. The Case for Bürolandschaft. In: DUFFY, F. (ed.) *The Changing Workplace*. London: Phaidon Press Limited.
- DUFFY, F. 1992. *The Changing Workplace*, London, Phaidon Press Limited.
- FANGER, P. O. 1970. *Thermal Comfort; Analysis and Applications in Environmental Engineering*, New York, McGraw-Hill Book Company.
- FORTY, A. 1986. *Objects of Desire: Design and Society: 1750*, Thames & Hudson.
- GADSIÖ, A. 2006. *Hur påverkas hyresgäst Anpassningar framtida hyresintäkter? (How Does Improvement in Tenant Influence The Future of Rental Income?)*. KTH.
- GAUCHEREL, C., BERARD, S. & MUNOZ, F. 2011. *Equation or Algorithm: Differences and Choosing Between Them*. Acta Biotheor, 59, 67-79.
- GLASER, B. G. & STRAUSS, A. L. 1967. *The discovery of grounded theory : strategies for qualitative research*, Chicago: Aldine Pub. Co.
- HARRIS, R. 2006. *Real Estate and the Future*. In: WORTHINGTON, J. (ed.) *Reinventing the Workplace*. London: Architectural Press, Elsevier.
- HAWKES, D. 2002. *The Selective Environment; An approach to environmentally responsive architecture*, London, Spon Press.
- HITCHINGS, R. 2009. *Studying Thermal Comfort in Context*. Building Research and Information, 37, 89-94.
- HOOKWAY, B. 2009. *Rules of Engagement: Architecture Theory and the Social Sciences in Frank Duffy's 1974 Thesis on Office Planning*, Princeton University.
- HUIZENGA, C. 2011. *ASHRAE Thermal Comfort Tool CD, Version 2: Maintains Consistency with ANSI/ASHRAE Standard 55-2010*. ASHRAE.
- HUMPHREYS, M. A. 1996. *Thermal Comfort Temperatures World-Wide: The Current Position*. WREC 1996.
- HUMPHREYS, M. A. & NICOL, J. F. 2002. *Adaptive Thermal Comfort and Sustainable Thermal Standards for Buildings*. Energy and Buildings, 34, 563-572.
- KATSIKAKIS, D. 2006. *New Real Estate Models to Support Distributed Working*. In: WORTHINGTON, J. (ed.) *Reinventing the Workplace*. London: Architectural Press, Elsevier.
- KRONER, W. M. 2006. *Employee Productivity and the Intelligent Workplace*. In: CLEMENTS-CROOME, D. (ed.) *Creating the Productive Workplace*. London: Taylor & Francis.
- LAING, A. 2006. *New Patterns of Work: The Design of the Office*. In: WORTHINGTON, J. (ed.) *Reinventing the Workplace*. London: Architectural Press, DEGW.
- LEE, S. Y. & BRAND, J. L. 2005. *Effects of control over office workspace on perceptions of the work environment and work outcomes*. Elsevier.

- MARMOT, A. & ELEY, J. 2000. *Office Space Planning; Design for Tomorrow's Workplace*, New York, London, Sydney, McGraw-Hill.
- MEIR, I. A., CARB, Y., JIAO, D. & CICELSKY, A. 2009. *Post Occupancy Evaluation: An Inevitable Step Toward Sustainability*. Advances in Building Energy Research, Earthscans Journals. Santamouris: aber.
- MELIKOV, A. 2004. *Personilised Ventilation*. Indoor Air, 14, 157-167.
- MYERSON, J. *Power of the Network: Transitions in Working Life from Taylorist Time and Motion to Networked Space*. In: GLYNNE, J. & IACKNEY, F., eds. *Networks of Design: Proceedings of the 2008 Annual International Conference of the Design History Society (UK)*, 2008 University College Falmouth. Universal Publishers.
- NEWSHAM, G., BRAND, J., DONNELLY, C., VEITCH, J., ARIES, M. & CHARLES, K. 2009. *Linking Indoor Environment Conditions to Job Satisfaction: A Field Study*. Building Research and Information, 39, 129-147.
- NICOL, F. & HUMPHREYS, M. A. 2005. *Maximum Temperature in Buildings to Avoid Heat Discomfort*. International Conference 'Passive and Low Energy Cooling for the Built Environment'. Santorini, Greece.
- NICOL, F., HUMPHREYS, M. A. & ROAF, S. 2012. *Adaptive Thermal Comfort: Principles and Practice*, Routledge.
- NICOL, J. F. & HUMPHREYS, M. A. 1973. *Thermal comfort as part of a self-regulating system*. Building Research & Information, 1, 174-179.
- ROAF, S., HORSLEY, A. & GUPA, R. 2004. *Closing the loop; Benchmarks for sustainable buildings*, London, RIBA Enterprises Ltd.
- SHAHZAD, S. S. 2013. *Quantitative vs. Qualitative Methodologies to Investigate Environmental Control in the Workplace: Neutral Thermal Sensation and Thermal Environmental Intention*. PLEA: Sustainable Architecture for a Renewable Future. Munich: PLEA.
- VAN MEEL, J. 2000. *The European Office: Office Design and National Context*, Rotterdam, 010 Publishers.
- VAN MEEL, J. & DE JONGE, H. 2006. *Office Cultures: International Differences in Workplace Design*. In: WORTHINGTON, J. (ed.) *Reinventing the Workplace*. London: Architectural Press, Elsevier.
- WAGNER, A., GOSSAUER, E., MOOSMANN, C., GROPP, T. & LEONHART, R. 2007. *Thermal comfort and workplace occupant satisfaction: Results of field studies in German low energy office buildings*. Energy and Building, 39, 758-769.

Proceedings of 8th Windsor Conference: *Counting the Cost of Comfort in a changing world* Cumberland Lodge, Windsor, UK, 10-13 April 2014. London: Network for Comfort and Energy Use in Buildings, <http://nceub.org.uk>

A comparison of alternative occupant classification approaches for the modelling of window opening behaviour in office buildings

Shen Wei, Richard Buswell and Dennis Loveday

Building Energy Research Group, School of Civil and Building Engineering,
Loughborough University, UK, S.Weii@lboro.ac.uk

Abstract

In the past 20 years, better representation of occupants' window operation in building performance simulation has received great attention, and several useful window opening behaviour models have been developed. Beyond these, this paper describes the development of window opening behaviour models based on alternative occupant classification approaches, namely, modelling occupants' window operation actions as a whole; modelling actions based on sub-groups (i.e. gender, floor level, etc.); and modelling window actions of groups based on the observed propensity to operate windows (tendency to leave open, closed, etc.). The paper examines the benefits of more specifically modelling occupants' action versus modelling actions more generally, in terms of predication accuracy. A comparison between predictive performances reveals that modelling occupants' behaviour based on their observed personal preference helps improve the accuracy of the model predictions, when compared with traditional approaches, but requires a greater degree of knowledge about personal preferences of a building's occupants.

Key words: Building performance simulation, window opening behaviour, behaviour modelling, personal preference.

1. Introduction

Natural ventilation and mixed-mode ventilation are becoming common place when designing commercial buildings in the UK (CIBSE, 2004), aiming to save energy used to provide comfortable indoor thermal environments in summer. In these types of buildings, ventilation is directly related to the room occupants' operation of windows, unless the windows are controlled by mechanical systems. Therefore, the occupants of these buildings have a key role to play in the performance and energy efficiency of the building operation (Fabi et al., 2012). Due to this, better representation of building occupants' window operation in building simulation has gained much attention since 1990s (Roetzel et al., 2010).

The traditional way of predicting occupants' window opening behaviour in building performance simulation is by deterministic processes, either following a fixed schedule or using typical control rules (Borgeson and Brager, 2008). However, several studies have shown that the interaction of people with window operation is much more complex and should be better predicted by stochastic processes (Nicol and Humphreys, 2004). These studies have developed useful window opening behaviour models based on the observed behaviour of occupants in actual buildings, with regard to their operation of windows (Zhang and Barrett, 2012, Yun and Steemers, 2010, Haldi and Robinson, 2009, Haldi and Robinson, 2008, Yun et al., 2008, Herkel et al., 2008, Rijal et al., 2007). These models, however, have been based on either modelling

the occupants of a building as a whole, or by modelling sub-groups of the whole population, for example, developing different window opening behaviour models for those occupants working on the ground floor and for those working on non-ground floors. However, these modelling approaches neglect the behavioural difference between individual occupants. Therefore, this study imports personal behavioural preference into the modelling of window opening behaviour and discusses whether a preference-based modelling approach has advantages over approaches based on whole-population or sub-group classification, in terms of accuracy, for the case of the end-of-day position of windows in non-air-conditioned office buildings.

The paper starts with an introduction of various occupant classification approaches used for modelling occupant window opening behaviour in office buildings. Then the methodology that has been used in the study is described, including data collection, model development, model validation and model comparison. Subsequent to this, the results of this study are expressed, followed by a discussion about the limitations of using the preference-based modelling approach in building performance simulation. Conclusions of this study are provided at the end of the paper.

2. Occupant classifications

Table 1 lists several factors that can influence occupant window operation in non-air-conditioned office buildings, based on an extensive review of literature (Wei, 2014).

Table 1. Factors having influence on window operation in non-air-conditioned office buildings.

Environmental factors	Non-environmental factors		
Outdoor climate (dominated by outdoor air temperature)	Season	Time of day	Previous window state
	Presence	Window type	Windows orientation
	Floor level	Shared offices	Building type
Indoor climate (dominated by indoor air temperature)	Room type	Heating system type	Occupant age
	Occupant gender	Personal preference	

Generally, there are three ‘tiers’ of viewing the above factors as attention extends from the whole building population to the individual:

1. factors affecting the whole building population, including outdoor climate, indoor climate, season, time of day, previous window state and presence;
2. factors classified by occupant sub-groups, including window type, window orientation, floor level, shared offices, building type, room type, heating system type, occupant age and occupant gender; and,
3. personal preference.

The first tier defines the factors that are common to all building occupants, so the factors belonging to this level are named as ‘whole-population factors’. The second tier includes the factors that can further classify the building occupants into several sub-groups, beyond the influence from the whole-population factors. Therefore, these factors are named as ‘sub-group factors’. These factors are often related to the properties either of the building itself, for instance, floor level and window orientation, or of the occupants within the building, taking into consideration such factors as occupant gender and age. Consideration of sub-group factors reflects the fact that occupants’ window opening behaviour may well differ between sub-groups of the whole building population, mostly influenced by the design of the building or the characteristics of the building occupants. Personal preference can influence people’s behaviour, beyond the influence of other factors. This means that even when all other factors are identical, occupants may also perform different window operations. This paper aims to evaluate the advantages of modelling occupant window opening behaviour with a deeper consideration of the third-tier factors, comparing to more common approaches that are based on the first two tiers of factors.

3. Methodology

This section expresses the methods that have been used to achieve the aim of this study, including the data collection, model development, model validation and model comparison.

3.1 Data collection

The study was carried out in the building that houses the School of Civil and Building Engineering at Loughborough University, UK (52°45’54’’N, 1°14’15’’W, alt.70m). Figure 1 depicts the Southwest façade of the building and shows a typical office. The building is an ‘L’ shape with single-occupied cellular offices around the perimeter, all of which have nominally the same floor area (10.2m²). Each window shown in Figure 1 belongs to an individual office. The office window in each monitored office can be set normally to one of two positions, either closed or open to a limited position (Figure 2). Although the outside of the building is curved, there are essentially only two façades, one facing Southwest and the other Northwest. The exterior of the building is covered by a mesh, which is designed to both shade the façade and provide a degree of security on the ground floor, allowing windows to be left open with reduced risk of theft. Each occupant in the building has sole control over the environmental conditions in his/her office and typical adaptive opportunities are: window and door positions, a window blind position and temperature control for a dedicated radiator (operative during the heating season).

To capture occupants’ window behaviour determining the end-of-day window positions, a longitudinal survey was carried out between 20 June and 30 September 2010 (72 working days in total). In the survey, the state of windows of 36 single-cell offices was monitored and these offices were located on two façades and three floors of the case study building. Indoor air temperature and outdoor air temperature were measured automatically every 10 minutes by sensors (Figure 3). Occupants’ daily presence (whether working in their offices on a particular day, which impacts upon the possibility of making decisions on the end-of-day window positions for that working day) was determined by three observations during the day time, i.e. 10:00am, 11:30am and 3:00pm. If occupancy was observed at any of these times, then occupant presence for that working day was recorded. The end-of-day window position (or

window position on departure) of each office was noted by a further observation at 8:00pm when most occupants had vacated the building (on a typical day).



(a) Case study building



(b) A typical single-cell office

Figure 1. The case study building (left) and a typical single-cell office (right).



a) Closed



b) Open

Figure 2. Positions of the window in the monitored office.



(a) Hobo UA-001 temperature sensor



(b) Delta-T WS-GP1 weather station

Figure 3. Automated measurement in the study.

3.2 Model development

In the study, logistic regression analysis (Hosmer and Lemeshow, 2000) was used as the basic statistical approach for the development of window opening behaviour models. A logistic regression model defines the probability of a specific event happening, such as opening a window, according to various influencing factors, which can be both numerical (e.g. temperature) and categorical (e.g. floor level). Equation 1 presents the basic form of a logistic model,

$$p = e^{A+B_1 \times x_1 + \dots + B_k \times x_k} / (1 + e^{A+B_1 \times x_1 + \dots + B_k \times x_k}), \quad (1)$$

where p is the estimated probability of a specific event happening; A is a constant (intercept); x_1 to x_k are model predictors and B_1 to B_k are regression coefficients of each predictor.

In the later analysis, the *Nagelkerke R² statistic* from the logistic regression analysis is used to evaluate the goodness-of-fit of the developed model to the real measured data. It covers the full range from 0 to 1, just like the multiple correlation coefficient used in the classical regression analysis (Rao, 1973), and measures the proportion of variance ‘explained’ by the logistic regression model.

3.3 Model validation

Prior to being used for predicting window states, window opening behaviour models developed in this study should be validated to make sure that they have captured the underlying nature of occupants’ behaviour on the end-of-day window position. To do this, a new set of data was collected from the same offices between 20 June and 18 September 2011 (63 working days in total). In the validation process, all models developed in the study were used separately to predict the monitored end-of-day window states in this new dataset, and their predictive performance on this dataset was compared with the one on the dataset that has been used to develop the models. If the model has consistent predictive performances for the two datasets, then it is judged as having captured the underlying nature of occupants’ behaviour on the end-of-day window position, and hence can be used to predict the state of windows. In this study, the model’s predictive performance was represented by a parameter named as the ‘percentage of exact matched days’, noting as a % of EMDs. It was calculated as the percentage of days with correctly predicted window states (both predicted window state and observed window state are open or both are closed) in the total number of prediction days.

The window state prediction was carried out by a stochastic process containing five steps:

Step 1: Initialisation

Set the initial end-of-day window position for the current prediction day: State = 0 (1: window open and 0: window closed)

Step 2: Reading inputs

Read essential inputs requested by the logistic behaviour model for the current prediction day

Step 3: Probability calculation and random number generation

- i. Calculate the probability of windows being left open on departure by substituting the essential inputs obtained in Step 2 into the logistic behaviour model (p_{open})
- ii. Generate a random number following $p_{random} \sim U[0,1]$ (p_{random})

Step 4: Evaluation

Determine the end-of-day window position based on the following criteria

- a. IF $p_{random} \leq p_{open}$, THEN the end-of-day window position for the current prediction day is set as open
- b. OTHERWISE, the end-of-day window position for the current prediction day is set as closed

Step 5: Prediction forward

Repeat Steps 1 to 4 for the next prediction day until it reaches the end of the prediction process

The above process has been used in previous studies to stochastically predict window states, by Rijal et al. (2007), Fritsch et al. (1990) and Yun and Steemers (2010).

3.4 Model comparison

The advantages of the preference-based modelling of window opening behaviour were investigated by comparing its predictive performance on the window state with those of the two models developed by more common occupant classification approaches, using the same dataset. The prediction of window states was achieved by the stochastic process described above. In the comparison, a higher % of EMDs value meant that the model can better reproduce the monitored end-of-day position of windows, hence the occupant classification approach used to develop the model can better capture occupant window opening behaviour in real buildings.

4. Results

In a paper published already (Wei et al., 2013), the authors have evaluated the influences of potential factors on the occupants' choice of the end-of-day window position in the case study building, using a systematic approach in an attempt to isolate dependencies. The factors investigated included season (summer or winter), change to daylight saving time (before or after), occupant absence in subsequent days (present or absent), window orientation (southwest or northwest), floor level (ground floor or non-ground floors), gender (males or females) and personal preference¹ ('habitual closers', 'adjusters' or 'leave openers'). After this process the factors that demonstrate the great influence were outdoor temperature on departure, season, gender, floor level and personal preference. The data used in this paper was collected for the summer months only, so the influence of season was neglected. This paper has used the remaining influencing factors to model the monitored end-of-day

¹ Habitual closers are occupants who almost always close windows at the end of the day; Leave openers are people who leave windows open on departure for most working days; Adjusters are someone between Habitual closers and Leave openers, who seem to adjust the end-of-day window position depending on thermal conditions.

window position in the case study building, based on various occupant classification approaches, to explore the advantages of modelling occupant window opening behaviour based on observed personal preference versus modelling this action more generally. Figure 4 presents a hierarchy of building population classification with respect to occupant window opening behaviour on the end-of-day window position in the case study building.

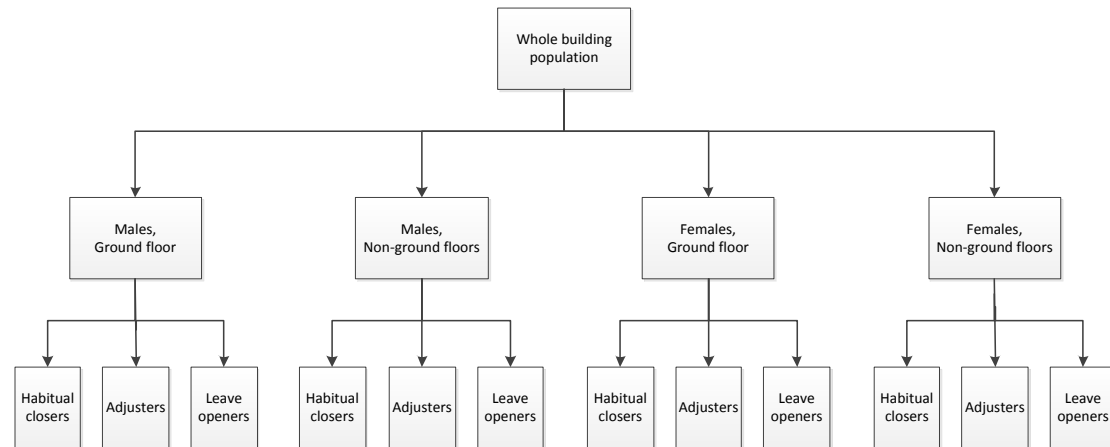

Figure 4. A hierarchy of building population classification with respect to window opening behaviour.

The development of window opening behaviour models was carried out in the IBM SPSS Statistics V19 (IBM, 2012), using the logistic regression analysis function. Based on the various occupant classification approaches introduced in Section 2, three logistic models were generated: a whole-population model (Equation 2), a sub-group model (Equation 3) and a (personal) preference model (Equation 4). The whole-population model only considers the influence of outdoor temperature on occupants' window operation so T_{out} (outdoor air temperature on departure) is the only predictor in the model. The sub-group model imports the various behavioural responses of different sub-groups to the outdoor air temperature so factors *GENDER* (either males or females) and *GFLOOR* (either ground floor or non-ground floors) are added to the modelling. The preference model considers the occupants' personal preference of opening windows regarding to outdoor air temperature, so T_{out} and *USER_TYPE* (either habitual closers, adjusters or leave openers) are used as predictors.

$$p_{whole-pop} = \frac{e^{-4.093+0.155 \times T_{out}}}{1+e^{-4.093+0.155 \times T_{out}}}, \quad (2)$$

$$p_{sub-group} = \frac{e^{-5.085+0.16 \times T_{out}+1.49 \times GENDER-1.35 \times GFLOOR}}{1+e^{-5.085+0.16 \times T_{out}+1.49 \times GENDER-1.35 \times GFLOOR}}, \quad (3)$$

$$p_{preference} = \frac{e^{-8.582+0.244 \times T_{out}+3.632 \times USER_TYPE(1)+5.946 \times USER_TYPE(2)}}{1+e^{-8.582+0.244 \times T_{out}+3.632 \times USER_TYPE(1)+5.946 \times USER_TYPE(2)}}, \quad (4)$$

where *USER_TYPE(1)* and *USER_TYPE(2)* are two dummy variables that are used to define the three types of window users with respect to the end-of-day window position (Habitual closers: *USER_TYPE(1)*=*USER_TYPE(2)*=0; Adjusters: *USER_TYPE(1)*=1 & *USER_TYPE(2)*=0; Leave openers: *USER_TYPE(1)*=0 & *USER_TYPE(2)*=1).

Table 2 lists the *Nagelkerke R² statistic* of the three logistic models. These values suggest that, from a statistical viewpoint, the sub-group model has a better fit to the actual data than the whole-population model, and the preference model has the best goodness-of-fit amongst the three models. Their predictive performances on the window state will be compared in the later part of the paper.

Table 2. Statistical properties of the logistic models.

	Whole-population model	Sub-group model	Preference model
<i>Nagelkerke R² statistic</i>	0.074	0.187	0.600

Figure 5 shows the validation results of the three models developed above. It shows that the three window opening behaviour models have consistent predictive performances on both datasets, hence they are considered to have captured the underlying nature of occupants' behaviour on the end-of-day window position.

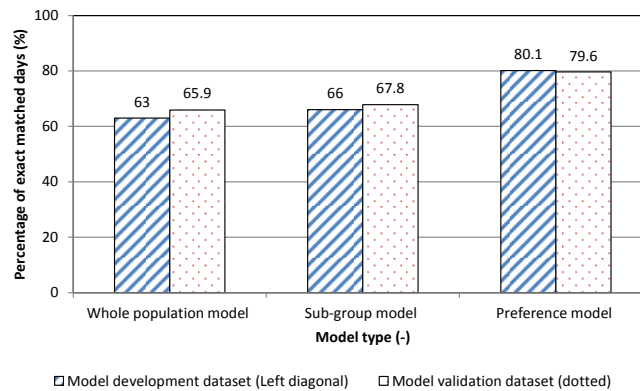

Figure 5. Validation of the three window opening behaviour models.

The main purpose of this paper is to evaluate whether modelling occupant window opening behaviour based on personal preference has advantages over approaches based on whole population or sub-groups, in terms of better-predicting window states. This is achieved by comparing the predictive performances of the three models on a single dataset, either the dataset used for developing the models or the new dataset collected for validating the models. The comparison results are shown in Figure 6, from which it can be seen that the preference model has a much better predictive performance, comparing to the whole-population model and the sub-group model, for both datasets. Meanwhile, the sub-group model has a slightly better predictive performance than the whole-population model.

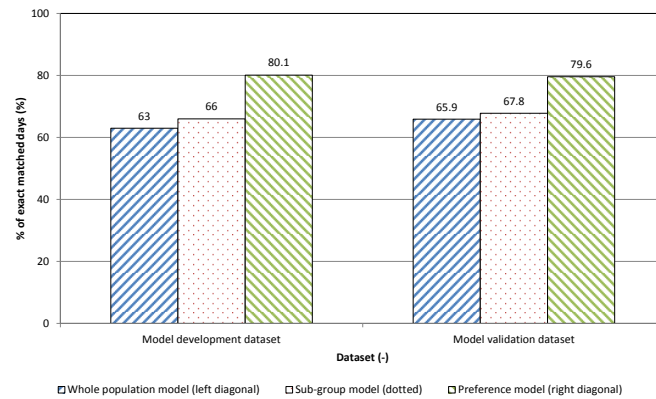

Figure 6. Model comparisons for the summertime.

5. Discussions

Occupants' window opening behaviour can be significantly different between individuals (Wei et al., 2013, Yun et al., 2009), and the preference-based approach of modelling window opening behaviour considers this difference. Modelling based on observed behavioural preference can improve model prediction accuracy. However, in practical simulation work, this observed characteristic of building occupants is not a known aspect of an individual, unlike the factors that are used in the other two approaches. Therefore, further explorations on how to assign personal preference in building performance simulation is still needed in future studies, especially for buildings with more than one office.

Another question is how to identify occupants' personal preference of window use in real buildings. Existing studies have used two methods, that is either based on real measured data (Yun et al., 2009, Haldi and Robinson, 2009) or based on occupants' self-statement (Rijal et al., 2007), and currently there is still no standard method that can be used to classify occupants based on personal preference. The three types of window users used in this study (habitual closers, adjusters and leave openers) were defined for occupants' behaviour determining the end-of-day window position in office buildings, and were based on a notion of mean outdoor air temperature and by threshold setting, using real measured data (Wei et al., 2013). It is suggested that the approach is repeated for other studies, so that the observed behaviours can be compared.

Conclusions

This paper has investigated the advantages of modelling occupant window opening behaviour based on personal preference over more common approaches that are based on either the whole building population or sub-groups within the building. The data used for the model development was collected from a non-air-conditioned office building located in the East Midlands of the UK. Based on the data, three window opening behaviour models, referring to occupants' choice of the end-of-day window position, have been developed, using three different occupant classification approaches, namely: whole population approach, sub-group approach and preference-based approach. All models have been validated as having captured the underlying nature of occupants' behaviour on the end-of-day window position, and hence can be used to predict the end-of-day window position for building performance simulation. Comparisons between their predictive performances on the window state have demonstrated that the preference-based modelling of occupant window opening

behaviour has a significant contribution to increasing the modelling accuracy, when compared with the other two approaches. However, as occupants' personal behavioural preference is generally not a known aspect of an individual when performing the simulation, the preference-based model requires a greater degree of knowledge about personal preferences of a building's occupants to implement.

References

BORGESON, S. & BRAGER, G. S. 2008. Occupant control of windows: accounting for human behavior in building simulation. Center for the built environment, University of California, Berkeley, USA.

CIBSE 2004. *CIBSE Guide F - Energy efficiency in buildings*, The Chartered Institution of Building Services Engineers London.

FABI, V., ANDERSEN, R. V., CORGNATI, S. & OLESEN, B. W. 2012. Occupants' window opening behaviour: A literature review of factors influencing occupant behaviour and models. *Building and Environment*, 58, 188-198.

FRITSCH, R., KOHLER, A., NYGARD-FERGUSON, M. & SCARTEZZINI, J. L. 1990. A stochastic model of user behaviour regarding ventilation. *Building and Environment*, 25, 173-181.

HALDI, F. & ROBINSON, D. 2008. On the behaviour and adaptation of office occupants. *Building and Environment*, 43(12), 2163-2177.

HALDI, F. & ROBINSON, D. 2009. Interactions with window openings by office occupants. *Building and Environment*, 44(12), 2378-2395.

HERKEL, S., KNAPP, U. & PFAFFEROTT, J. 2008. Towards a model of user behaviour regarding the manual control of windows in office buildings. *Building and Environment*, 43(4), 588-600.

HOSMER, D. W. & LEMESBOW, S. 2000. *Applied logistic regression (2nd Edition)*, New York: John Wiley & Sons, Inc.

IBM. 2012. *IBM SPSS Statistics* [Online]. Available: <http://www-01.ibm.com/software/analytics/spss/products/statistics/> [2012].

NICOL, F. J. & HUMPHREYS, M. A. 2004. A stochastic approach to thermal comfort - Occupant behaviour and energy use in buildings. *ASHRAE Transactions*, 110 (Part I), 554-568.

RAO, R. C. 1973. *Linear statistical inference and its application (2nd Edition)*, New York: John Wiley & Sons, Inc.

RIJAL, H. B., TUOHY, P., HUMPHREYS, M. A., NICOL, F. J., SAMUEL, A. & CLARKE, J. A. 2007. Using results from field surveys to predict the effect of open windows on thermal comfort and energy use in buildings. *Energy and Buildings*, 39(7), 823-836.

ROETZEL, A., TSANGRASSOULIS, A., DIETRICH, U. & BUSCHING, S. 2010. A review of occupant control on natural ventilation. *Renewable and Sustainable Energy Reviews*, 14, 1001-1013.

WEI, S. 2014. *Preference-based modelling and prediction of occupants' window behaviour in non-air-conditioned office buildings*. PhD, Loughborough University.

WEI, S., BUSWELL, R. & LOVEDAY, D. 2013. Factors affecting 'end-of-day' window position in a non-air-conditioned office building. *Energy and Buildings*, 62, 87-96.

YUN, G. Y. & STEEMERS, K. 2010. Night-time naturally ventilated offices: Statistical simulations of window-use patterns from field monitoring. *Solar Energy*, 84(7), 1216-1231.

YUN, G. Y., STEEMERS, K. & BAKER, N. 2008. Natural ventilation in practice: linking facade design, thermal performance, occupant perception and control. *Building Research & Information*, 36(6), 608-624.

YUN, G. Y., TUOHY, P. & STEEMERS, K. 2009. Thermal performance of a naturally ventilated building using a combined algorithm of probabilistic occupant behaviour and deterministic heat and mass balance models. *Energy and Buildings*, 41(5), 489-499.

ZHANG, Y. & BARRETT, P. 2012. Factors influencing the occupants' window opening behaviour in a naturally ventilated office building. *Building and Environment*, 50, 125-134.

A field study to validate the positive effects of individual control on thermal comfort in residential buildings

Maohui Luo¹, Bin Cao¹ and Yingxin Zhu¹

1 Department of Building Science, Tsinghua University, Beijing, China,
Corresponding email: luo_mao_hui@163.com

Abstract

Although the adaptive comfort model has gained unprecedented popularization during the past few decades, the mechanism behind the model, especially with regard to certain key hypotheses, still requires further clarification. To validate whether people with greater individual control tend to attain comfort state in wider ranges of indoor thermal environments, we designed an investigational study in Beijing apartments with different degrees of individual control over space heating systems. The statistical results show that occupants with individual control had lower neutral temperature during the winter time and expressed more positive comfort-related perceptions than those without capability of personal control. Furthermore, the mechanism of the positive impact of individual control was discussed in terms of adaptive processes and economic factors. The results show that individual control over space heating systems was helpful to ensure residents make their own trade-off between thermal comfort and heating fees. These findings can provide support for the adaptive model and can also serve as a reference for decision makers and designers when they choose appropriate residential space heating systems with concerns about residents' demand and conserving energy.

Keywords: adaptive thermal comfort, individual control, neutral temperature, residential space heating, economic factors

Nomenclature

T_a	Indoor air temperature (°C)
T_{op}	Operative temperature (°C)
RH	Relative humidity (%)
v	Air velocity (m/s)
MET	Metabolic rate
CLO	Clothing insulation (clo)

1 Background

During the past few decades, the adaptive comfort approach has gained unprecedented popularization due to increasing concerns about building environment improvement and the consequential need to enhance building energy efficiency (de Dear et al, 2013). Since the re-emergence of adaptive comfort approach, results of many field studies have given support to the fundamentally different but not new model (for instance, Karyono et al, 2002; Fato et al, 2004; Cao et al, 2011). Through numerous researchers' unremitting efforts, especially Brager and de Dear (1998; 2002) and Nicol and Humphreys (1998; 2002), the legitimacy of the adaptive comfort model has been recognized by recent comfort standards such as ASHRAE Standard 55 (2013), EN 15251 (2007) and even some national standards like Chinese GB/T 50785 (2012).

Compared with Fanger's Predicted Mean Vote and Predicted Percentage Dissatisfied (PMV-PPD) model (Fanger, 1970), which predicts human subjective sensation based on steady-state heat balance calculation of human body, the adaptive approach emphasized the role occupants play in attaining their own thermal comfort (de Dear and Brager, 1998). According to the adaptive hypothesis, the discrepancies between PMV and the observed comfort sensation in real buildings can be attributed to three adaptive processes: physiological acclimatization, behavioral adjustment (clothing, windows) and psychological habitation or expectation. To increase the rigor of the adaptive model and extend its application scope, many thermal comfort studies have been conducted in different contexts to offer support for the theory. For instance, de Dear (1998) and Nicol et al (2010) collected quality-ensured database from field investigations to derive the comfort equations in ASHRAE Standard and European standards EN 15251 respectively. Schweiker et al. (2012) developed and validated an experimental methodology to quantify the individual contributions of the three mentioned adaptive processes in warm indoor environments. To verify the effects of physiological acclimatization on human thermal adaptation, Yu et al (2012) demonstrated in climate chamber experiments that subjects who were acclimated to naturally ventilated environments had a significantly stronger capacity for physiological thermoregulation than those who were acclimated to air-conditioned environments. Yao et al (2009) developed a modified PMV model to reflect adaptive factors such as culture, climate, psychological and behavioral adjustments by proposing an adaptive coefficient. And concluded that their model could be a contribution as a bridge between lab-based PMV model and the adaptive comfort model.

However, despite great progresses have been made, there still exist some controversial hypothesizes in adaptive comfort model remain largely unresolved. Among all those controversies, one important hypothesis stated in this way: occupants in free-running buildings can achieve thermal comfort in a wider range of indoor temperatures compared to occupants in centrally controlled air-conditioning buildings because of the increased levels of personal control afforded by approaches like operable windows (de Dear and Brager, 1998). The main issue of this hypothesis is that whether different degrees of individual control can influence occupants comfort perception. Some researches doubted that the expectation hypothesis has not been confirmed by experimental or survey data, and its underlying premises and logic need rethinking and a more solid foundation (Halawa, 2012). To examine the relationships between individual control and occupants comfort perception, many comparative experiments were designed and conducted. Brager et al (2004) carried out a field study in a naturally ventilated office building, and found that occupants with more opportunities to operate windows reported temperatures closer to neutral than those who had less capability to control the windows, even though both groups were exposed to very similar thermal environments. Goto et al (2007) conducted a similar longitudinal study in six Japanese buildings, but they reported no considerable differences in occupants' thermal perception in the two groups of buildings. Zhang et al (2010; 2013) conducted field investigations in a hot and humid climate, and found that occupants in naturally ventilated buildings reported lower neutral temperatures than those in air-conditioned buildings. A more recent 'right here right now' chamber experimental study designed by Zhou et al (2013) reported that occupants' anticipated control decreased their thermal sensation vote (TSV) by 0.4-0.5 and improved their thermal comfort vote (TCV) by 0.3-0.4 in neutral-warm environment.

In addition to the consequential need to offer more solid support for the adaptive comfort theory, Chinese comfort researchers are also confronted with a more urgent and practical issue: centralized space heating and individual space heating, which one is more appropriate for residential buildings in China? Since the 1950s, most urban residential buildings in northern China have been equipped with district heating supply facilities having uncontrollable terminals, while most residents in southern China tended to heat their apartments individually. The 2010 National Statistical Yearbook shows that the district heating supplied buildings increased from 2.66 to 3.56 billion m², with an average annual growth of 0.3 billion m² (Ding et al 2011). Despite miscellaneous problems with district heating supply in the northern heating region, more and more people from southern region, especially the hot summer and cold winter zone, have been requesting district heating supply in residential buildings in order to improve living standards. Recently, a debate has arisen focusing on the issue mentioned above. Although this is a complicated problem involving aspects like energy structure, system design, economic factors, et al, it is noteworthy to mention a significant distinction between these two space heating systems in China: individual system allows users to adjust internal thermal conditions whenever they want, but centralized system users had little or no control capability over their immediate indoor climate. Therefore, it is meaningful to compare these two space heating systems from perspectives of indoor thermal environment, thermal comfort and heating energy consumption.

In accordance with previous researchers' contributions, we designed a field study and tried to answer the following issues: 1) how and to what extent do different degrees of personal control influence human comfort perception? 2) What benefits can we obtain if residents were offered with terminal controllable heating systems?

2 METHODS

2.1 Assumption

As graphically represented in Figure 1, if we assume the adaptive comfort model is credible, then the following results can be derived. Occupants with higher degrees of individual control could obtain more neutral thermal perception and more positive comfort related assessments. Therefore, if we design an investigation including two subject groups with different degrees of individual control, the results can be used to validate or challenge the basic hypothesis in adaptive comfort theory.

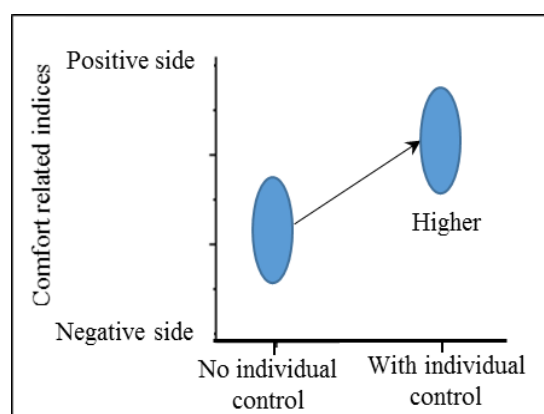

Figure 1 Graphical representation of the hypothesis

2.2 Investigation design and subjects selection

After extensive searches, we selected a residential community with two typical kinds of space heating systems in Beijing, North China (39°54'N, 116°25'E). Beijing is a typical city in the cold climate zone: the summer is warm, and the winter is cold and dry. The mean outdoor air temperature is 26.5°C in July and -3.8°C in January. The relative humidity is around 70% in summer and 42% in winter.

To recruit apartments with different degrees of individual control over space heating system, we chose 118 apartments in the target community to do this field investigation. As shown in Table 1, all these case apartments were divided into two groups. Group BJ-A were equipped with terminal uncontrollable district heating supply facilities. Occupants in this group had no direct way to control the indoor thermal environment. Group BJ-B were heated by individual space heating systems. Occupants in this group were able to control the indoor thermal environment by adjusting the set points of space heating systems. As most of these apartments were located in one community, other factors such as the presence of operable windows, the age of the building, and the spatial layout could be ensured to be similar in the initial background survey. Furthermore, no significant differences existed among subjects in terms of other characteristics such as age, gender, and annual income.

Table 1 Summary of the surveyed buildings

	Time	Number of apartments	Space heating system	Individual control
BJ-A	Dec. 2012 ~ Feb. 2013	Background level: 45 Detailed level: 15	District heating supply	No
BJ-B	Dec. 2012 ~ Feb. 2013	Background level: 41 Detailed level: 17	Individual household gas boiler heating	Free to adjust

2.3 Investigation content

To ensure the reliability of investigation results, we designed the study into two levels (as shown in Table 2). The detailed level aimed to record the indoor thermal conditions, occupants' perceived thermal comfort, and heating energy consumption in minute detail, while the goal of the background level was to extend the scope of the research and verify the results of the detailed level investigation. The apartments in the detailed study were observed continuously, and those in the background investigation were examined only once.

Table 2 Two investigation levels

Investigation level	Measurements
Background study	T_a , T_g , and RH
Detailed study	T_a , T_g , v , RH, and meteorological station

As for the investigation contents, both simultaneous measurements of physical parameters and subjective questionnaires were included in our methodology. Indoor thermal parameters were continuously measured at 5-minute intervals with different instruments; the valid ranges and accuracies of the monitoring instruments are listed in Table 3. In each surveyed apartment, sensors with self-recording loggers were placed about 1.0 meters above the floor in the living room, bedroom, and reading room.

Table 3 Accuracy of environmental monitoring instruments

Parameter	Valid range	Accuracy
T _a (°C)	5~35	±0.2
RH (%)	20~80	±3
v (m/s)	0~3	±5%
T _g (°C)	5~50	±0.2

Occupants' subjective sensations were determined by questionnaires including thermal sensation vote (TSV), thermal comfort vote (TCV), thermal preferences, thermal acceptance, etc. As shown in Table 4, the TSV adopted a seven-point scale ranging from cold (-3) to hot (+3), with neutral (0) in the middle. Thermal preferences were assessed using a three-point scale: 'warmer', 'no change', and 'cooler'. Clothing insulation was calculated in accordance with ISO 9920 (2009). In total, 657 valid questionnaires and corresponding indoor thermal conditions were collected.

Table 4 Thermal comfort index and its scale

Scale	TSV	TCV	Thermal acceptance	Thermal preference
3	Hot	--	--	--
2	Warm	--	--	--
1	Slightly warm	--	Very acceptable	Warmer
0	Neutral	Comfortable	Just acceptable or Just unacceptable	No change
-1	Slightly cool	Slightly uncomfortable	Very unacceptable	Cooler
-2	Cool	Uncomfortable	--	--
-3	Cold	Very uncomfortable	--	--

Additionally, in order to collect space heating energy consumption data of apartments in group BJ-B, we recorded their gas meter's readings before and after the detailed investigation. In this way, space heating gas consumption could be roughly calculated. To valid this results, we also collected heating gas consumption records in the background investigation.

3 RESULTS

3.1 Indoor thermal environment corresponding to questionnaires

Indoor thermal climates experienced by occupants tend to affect their thermal perception directly. Before we look into occupants' thermal response of these two groups, we would like to present the indoor thermal conditions corresponding to subjective questionnaires. As shown in Table 1, we divided the surveyed apartments into two groups according to degrees of individual control. Group BJ-A had no individual control over the indoor thermal climate, while the space heating systems in group BJ-B were terminal adjustable.

Figure 2 shows the distributions of indoor thermal parameters of group BJ-A and group BJ-B. The T_a mainly fell between 18°C and 24°C, and RH ranged from 20% to 50% in most cases. The conditions of low indoor temperature could also be observed in both groups. Compared with BJ-B apartments in some cases, BJ-A apartments might have higher T_{op} , but the proportion of these cases is quite small. To test whether there exist significant difference in comfort-related physical parameters between these two groups, Table 5 shows the independent sample test results (t-test). It can be seen that no significant difference in comfort-related parameters existed between group BJ-A and BJ-B, which means the occupants in these two groups experienced similar thermal environments when they were answering the questionnaires.

Table 5 Comfort-related thermal parameters (significance of difference is labeled ‘strong’ or ‘no’ for p-values < 0.05 in an independent samples t-test)

Parameters	BJ-A			BJ-B			Significance of difference
	Max	Ave	Min	Max	Ave	Min	
CLO	1.48	0.86	0.35	1.51	0.87	0.41	no
MET	1.4	1.2	1.0	1.5	1.2	1.0	no
T_{op}	28.4	21.5	14.6	25.3	21.3	14.3	no
v	0.56	0.02	0.00	0.28	0.02	0.00	no
RH	61.5	34.4	11.7	68	36.9	10.6	no

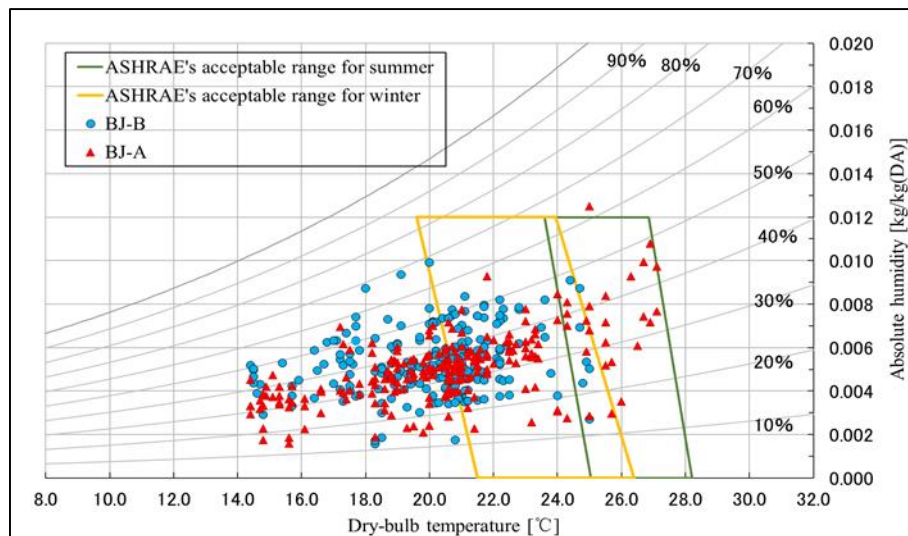

Figure 2 Distribution of indoor thermal parameters

3.2 Thermal comfort

To quantitatively describe occupants' subjective thermal perception, various comfort related indices (e.g. TSV, TCV, PMV, etc.) were proposed and relationships among these indices have been explored through large amount of well-designed experiments (Fanger, 1970). Through these indices, occupants could express their subjective opinions about whether indoor thermal conditions fulfilled their demands or not. If they were satisfied, they were supposed to vote a positive evaluation; otherwise, they could indicate their dissatisfied sensation by voting a negative value.

Figure 3 compares occupants' thermal perception from perspectives of TSV, thermal preference, thermal acceptance and TCV. Figure 3.a shows that occupants' TSV in both

groups were broadly distributed, but were mainly concentrated among the ‘neutral’ and ‘slightly cool or warm’ options. Compared with group BJ-A, higher percentage of occupants in BJ-B apartments vote ‘neutral’ sensation. Figure 3.b indicate that majority of occupants in both groups want to maintain their current indoor thermal conditions. However, group BJ-B had higher percentage of occupants choose ‘no change’ option. Figure 3.c shows occupants thermal acceptance options. Although both groups had the overwhelming majority (over 80%) of respondents that could accept their current thermal conditions, occupants in group BJ-B expressed higher acceptance percentage. Figure 3.d shows statistical distributions of TCV. It can be seen that group BJ-B had higher average comfort vote value.

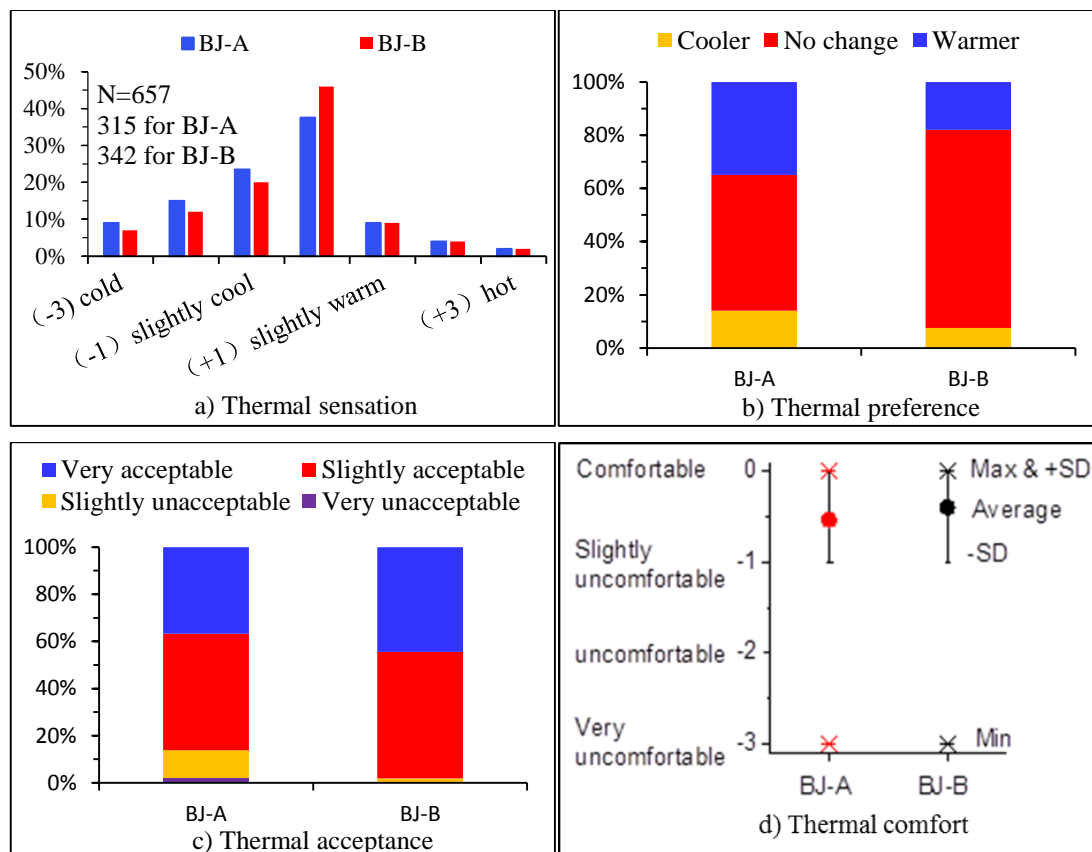

Figure 3 General comfort evaluation

To describe occupants’ thermal response with the change of indoor temperature, Figure 4 examines the relationships between occupants’ subjective thermal sensations and physical thermal indices. The linear regression fitting results for the divided two groups are illustrated in Figure 4. During the process of linear fitting, the weights of the valid vote numbers in each index bin were considered. The final regression models contained T_{op} (as the thermal environment index) and the mean TSV in each T_{op} bin; R^2 was regarded as an index of fitting accuracy. The results show that each group’s sensitivity (slope of the regression line) of TSV to T_{op} varied considerably, indicating substantial differences in occupants’ thermal responses. The slope of the regression line indicates that occupants in BJ-B apartments were less sensitive to variation of T_a , and therefore reported more neutral thermal sensation. With the ideal thermal environment defined as the neutral state, the neutral T_{op} was determined by solving regression equations with

TSV=0. In this way, the neutral T_{op} values for groups BJ-A and BJ-B were calculated as 20.7°C and 18.1°C respectively.

If we further compare Figure 3 and Figure 4 with Figure 1, it seems that the field investigation results support the hypothesis we assumed well: with higher degrees of individual control, occupants could obtain more neutral thermal perception and more positive comfort related assessments.

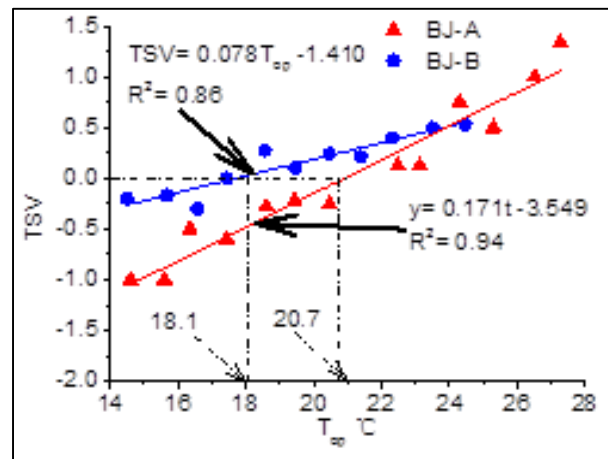

Figure 4 Linear regressions of TSV as a function of T_{op}

4 Discussion

Whether personal control can influence occupants' thermal comfort? This is an important basic hypothesis in adaptive comfort theory. Is it true? Many efforts (for instance Brager et al, 2004; Goto et al, 2007; Zhou et al, 2013) have tried to answer this question. If the hypothesis has been demonstrated to be true, then what is the mechanism behind it? And what can we learn from it? Furthermore, the results of this study support the hypothesis so well. Is there any other factors beyond individual control that can enlarge the differences between group BJ-A and BJ-B.

4.1 Individual control and thermal comfort

Can individual control ability improve human thermal comfort perception? There exist two academic opinions related to this problem. Fanger and Toftum (2002) assumed that occupants with low degrees of personal control believe it is their destiny to live in non-neutral environments, thus resulting in lower thermal comfort expectations. According to this assumption, occupants with fewer opportunities for personal control would demonstrate better thermal response when the thermal environment varied from neutral. In contrast, Nikolopoulou and Steemer (2003) supported the positive effects of individual control on perceived thermal comfort and hypothesized that people with high levels of control over the source of discomfort would be less irritated by it, thereby greatly reducing their negative emotional responses. Nikolopoulou and Steemer's opinion, which essentially states that high degrees of personal control can contribute to high thermal acceptance, is quite similar to the central notion of the adaptive comfort model. As de Dear and Brager (2002) stated: "the primary distinction between the building types was that the NV buildings had no mechanical air-conditioning, and the natural ventilation occurred through operable windows that were directly controlled by the occupants. In contrast, occupants of the HVAC buildings had little or no control over their immediate thermal environment."

To demonstrate the hypothesis that people with higher degrees of personal control tend to accept wider range of indoor thermal environment, both field studies and chamber experiments have been conducted. Table 6 lists some findings of these studies. It can be observed that occupants with higher degrees of personal control tended to report more positive comfort evaluation and have closer match of indoor neutral temperatures with outdoor climates (higher neutral temperature in warm season but lower neutral temperatures in cool season). These findings offer good support for the hypothesis in the adaptive model proposed by de Dear and Brager (2002) and Nicol and Humphreys (2002).

AS for the question why higher degrees of individual control can contribute to more comfortable perception, it may be explained in this way: occupants with more personal individual control approaches tend to have an increased ability to keep themselves in a comfortable state by removing the source of discomfort in a timely manner, thus resulting in more positive comfort related evaluation and lower motivation to change their current thermal environment.

Table 6 Evidences support the positive effects of individual control on thermal comfort

Ref.	Season conditions	Location	Building types	Degrees of personal control	Neutral temperature °C
Brager et al (2004)	Summer	San Francisco	Office building	Low	23(T _{op})
			Office building	High	21.5(T _{op})
Present study	Winter	Beijing	Residences	No	20.7(T _{op})
			Residences	High	18.1(T _{op})
de Dear et al (1991)	Summer	Singapore	Air conditioned	Low	24.2 (T _{op})
			Naturally ventilated	High	28.5(T _{op})
Zhou et al (2013)	Warm conditions	Beijing	Air conditioned	Low	Higher TSV
			Air conditioned	High	Lower TSV
Schweiker et al (2013)	Warm conditions	Germany	Air conditioned	Low	Higher TSV
			Air conditioned	High	Lower TSV

4.2 Factors beyond individual control: who should pay for the space heating?

Although the above analysis have tried the best to explain that the difference in the thermal comfort is mainly (if not purely) due to the difference in terms of personal control, one may still doubt: is there any other factors beyond individual control that can influence the results? Indeed, the payments of these two heating forms were different. The following section aims to analyze the effects of economic factors on occupants comfort perception and their adaptive behaviors.

From the point of view of residents, heating fee is a crucial consideration when they evaluate different heating forms. It is therefore very important to compare the cost of different heating forms. Take a 100 m² house, for instance; Table 7 shows the detailed heating fee comparison. For BJ-B apartments the heating fee varied in the range of 285.9-515.6 US\$/a, while BJ-A occupants had to pay 407.5~489.0 US\$/a. The heating fee of BJ-B apartments were determined by the actual amount of gas they consumed, while BJ-A apartments had to pay in a one-size-fit-all mode, which means almost every BJ-A apartment should pay the same.

Table 7 Economic analysis of a 100 m² house

Heating form	Beijing	
	GH	DHS
HGC, m ³ /(m ² a)	5.6~12.4	0
HEC, KWh/(m ² a)	0	0
Natural gas price, US\$/m ³	0.34	0
Costs for equipment, US\$/a	97.8 ¹	0 ²
Gas fee, US\$/a	188.1~416.3	0
Electricity fee, US\$/a	0	0
Heating fee, US\$/a	285.9~515.6	407.5~489.0

As individual control approaches allow occupants in BJ-B apartments to determine internal thermal conditions and heating fees based on their own choice, the diversity of individual heating demands in such apartments emerged. Figure 5 shows the internal temperature distribution of detail investigated BJ-B apartments. It can be seen that the average T_a in these apartments varied from 15.9°C to 24.1°C, highlighting the fact that heating demand in each household was different.

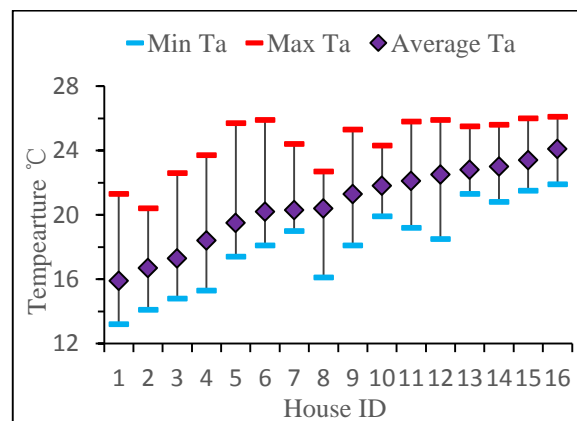

Figure 5 Temperature distribution in BJ-B apartments

Figure 6 show the relationships between heating energy consumption and mean heating temperature in BJ-B apartments. As all case apartments in BJ-B were located in the

¹ The initial costs of household gas boiler is 1467 US\$. Assume it can work 15 years, so the average cost is 97.8 US\$/a.

² The initial costs of central heating facilities was excluded. Because most of them are public infrastructure. If this part of investigation were taken into consideration, the heating fee of BJ-A would be higher.

same community, and had similar building construction, factors like building envelopes and heating system efficiencies were rather secondary to influence heating energy consumption. Therefore, it can be concluded that the mean heating temperature is the major factor that influences heating energy consumption.

Besides mean heating temperature, some residents thought proper T_a control might conserve heating energy. Figure 7 illustrates three T_a control modes: mode1 had a similar mean internal temperature as mode2, but T_a fluctuated more. Mode3 had similar T_a fluctuation as mode2, but the mean heating temperature was lower. We found that the gas consumption of space heaters in mode2 and mode3 were obviously different, while the gas consumption of mode1 and mode2 were quite similar. Therefore, in terms of T_a fluctuation, mean heating temperature was the main factor influencing heating gas consumption in BJ-B apartments. However, it is worth noting that if T_a can fluctuate properly according to occupants' lifestyles, it can improve the occupied indoor thermal environment.

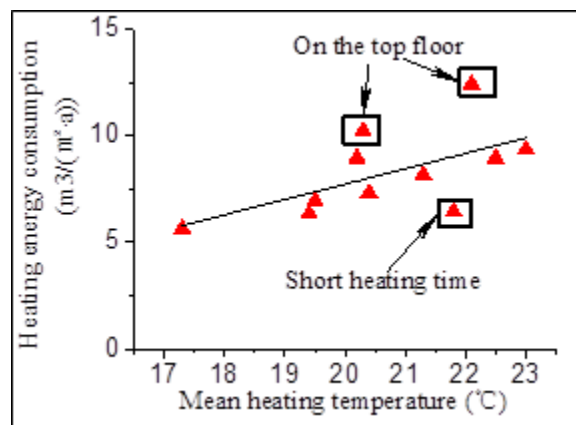

Figure 6 Relationships between heating energy consumption and the mean heating temperature

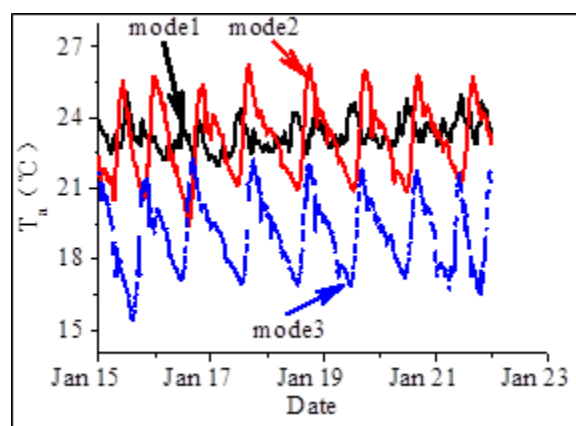

Figure 7 Three T_a control modes

4.3 What happened behind individual control approaches?

The above discussions demonstrated the diversity of occupants' choices when they were confronted with the trade-off between thermal comfort and heating fee. Exactly due to this kind of trade-off, Residents were encouraged to choose different indoor thermal conditions and corresponding adaptive behaviors. So, what happened during the process of the trade-off? What kind of role does individual control play?

To illustrate how occupants adjust to the environment with and without personal control over indoor thermal conditions, Figure 8 shows the adaptive behaviors among groups BJ-A and BJ-B. There are many forms of adaption in residential buildings, such as adjusting clothing, opening windows, drinking cold or warm drinks, etc. However, occupants in BJ-B apartments have more effective approaches for dealing with non-neutral thermal conditions because they can create preferable indoor thermal conditions by resetting the space heating temperature lower or higher as necessary. This may be a plausible explanation for why BJ-B apartments have a higher percentage of occupants who want to maintain their indoor thermal conditions. Upon closer examination of the frequency of each adjustment approach in BJ-B buildings, it is interesting that occupants tended to choose a lower heating temperature first when they felt hot but chose to add clothing first when they felt cold. We attribute this phenomenon to economic effects, as a lower space heating temperature will result in lower heating fees.

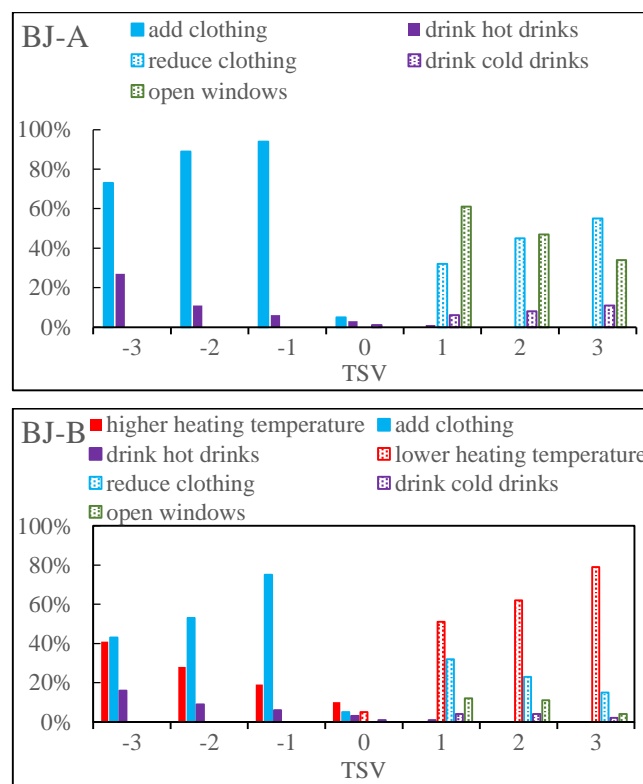

Figure 8 Adjustment approaches

Based on the analysis above, Figure 9 and Figure 10 illustrate occupants' trade-off processes in apartments with and without personal control over space heating systems. Why residents in BJ-B apartments reported more positive comfort related evaluation on their current internal thermal conditions? One reason may be that people with more personal control approaches tended to have increased ability to keep themselves in a comfortable state by removing the source of discomfort in a timely manner. Another reason may be that the feasibility of individual control over space heating systems allows residents to make their own trade-off between indoor thermal conditions and heating fees. The internal temperatures may depart from neutral comfort state (for instance, T_a was lower than the comfort temperature), but occupants were more likely to accept or adjust it instead of complaining immediately because it was their own choices.

However, for apartments without individual control, the situation was quite different. Firstly, occupants in such apartments had to accept their current internal thermal conditions passively, no matter it was comfortable or uncomfortable. When uncomfortable conditions occurred, less adaptive approaches were useful for them to adapt themselves to the indoor thermal environment. Secondly, there was no chance for them to make a trade-off between thermal comfort and heating fee. Once discomfort occurred, they were more likely to complain the heating systems.

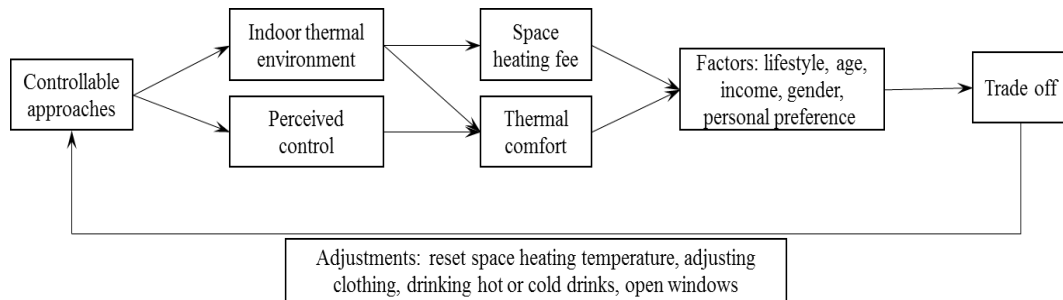

Figure 9 Trade-off processes in apartments with individual control

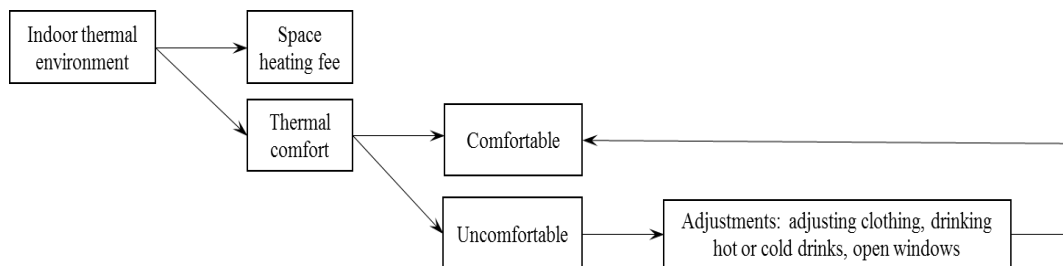

Figure 10 Passive acceptance processes in apartments without individual control

5 Conclusions

1) Occupants with capability of individual control had lower neutral temperature in winter time and reported more positive comfort-related perceptions than those without capability of personal control. The calculated neutral temperature of group BJ-B was 2.6 °C lower than group BJ-A, which indicates that occupants in BJ-B were more likely to vote neutral thermal sensations. To validate whether the difference in thermal comfort is mainly due to different degrees of personal control, we tried to compare the indoor thermal conditions of BJ-A and BJ-B apartments by conducting an independent samples t-test (as shown in Table 5) and by mapping the distribution of indoor thermal conditions corresponding to the questionnaires (as shown in Figure 2). In these analyses, we observed no significant differences between groups BJ-A and BJ-B, except that BJ-A apartments might have had an indoor temperature higher than 26°C. But the difference was quite small and was precisely due to a lack of personal control. Additionally, although the difference in neutral operative temperature between BJ-A and BJ-B apartments was 2.6°C, the differences in air temperature, humidity, and wind velocity were rather small. Furthermore, we tried the best to collect more evidences to support the effects of individual control from previous studies. Therefore, we believe the difference in thermal comfort is mainly (if not purely) due to the difference in personal control.

2) The capability of individual control over space heating systems allow residents to make their own trade-off between perceived thermal comfort and the space heating fees. Indeed, residents with higher degrees of personal control capability tended to have increased ability to keep themselves in a comfortable state by removing the source of discomfort in a timely manner. Except of this perceived control effects, we believe the feasibility of individual control and the more flexible payment mode in individual space heating apartments can also encourage residents to make their own choices between thermal comfort and heating fee. This may be why BJ-B occupants tended to choose a lower heating temperature first when they felt hot but chose to add clothing first when they felt cold (as shown in Figure 8). And this can also explain why no overheat situations occurred in BJ-B apartments (as shown in Figure 2). These findings can serve as good reference when we choose the way to pay for our comfort.

3) It is recommended that occupants be offered sufficient opportunities to interact with the thermal environment through individual adaptive approaches such as operable windows, personal fans or terminal controllable HVAC systems. It appears that the best way to meet occupants' thermal comfort demand is to allow them make their own choices based on individual desires. This is especially true in residential buildings, where differences in personal preferences and lifestyle may be more pronounced, and individual adaptive approaches is a feasible way to offset these inherently different space conditioning demands.

6 Acknowledgements

This study was supported by the Natural Science Foundation of China (50838003) and China Postdoctoral Science Foundation (2013M530633). The paper uses some material first published in Luo et al (2014).

References

ASHRAE, 2013. *Thermal Environmental Conditions for Human Occupancy*, ASHRAE Standard 55. Atlanta: American Society of Heating, Refrigerating and Air-Conditioning Engineers.

Brager, G., de Dear, R.J., 1998. Thermal adaptation in the built environment: a literature review. *Energy and Buildings*, 27 (1), pp 83-96.

Brager, G.S., Paliaga, G. and de Dear, R.J., 2004. Operable windows, personal control and occupant comfort, *ASHRAE Transactions*, 110(2), pp 17-35.

BS EN ISO 9920, 2009. *Ergonomics of the thermal environment — Estimation of thermal insulation and water vapor resistance of a clothing ensemble*. UK: British Standards Institution.

Cao, B., Zhu, Y.X., Ouyang, Q., Zhou, X. and Huang, L., 2011. Field study on human thermal comfort and thermal adaptability during the summer and winter in Beijing. *Energy and Buildings*, 43(5), pp 1051-1056.

CEN, 2007. *Indoor Environmental Input Parameters for Design and Assessment of Energy Performance of Buildings: Addressing Indoor Air Quality, Thermal Environment, Lighting and Acoustics*, EN 15251. Brussels: European Committee for Standardization.

de Dear, R.J., Leow, K.G., et al, 1991. Thermal comfort in the humid tropics: Field experiments in air conditioned and naturally ventilated buildings in Singapore. *International Journal of Biometeorology*, 34(4), pp 259-265.

de Dear, R.J., 1998. A global database of thermal comfort field experiments. *ASHRAE Transactions*, 104, pp 1141-1152.

de Dear, R.J. and Brager, G., 1998. Developing an adaptive model of thermal comfort and preference. *ASHRAE Transactions*, 104, pp 145-167.

de Dear, R.J., Brager, G., 2002. Thermal comfort in naturally ventilated buildings: revisions to ASHRAE Standard 55. *Energy and Buildings*, 34 (6), pp 549-561.

de Dear, R.J., Akimoto, T., Arens, E. A., Brager, G., Candido, C., Cheong, K.W.D., Li, B., Nishihara, N., Sekhar, S.C., Tanabe, S., Toftum, J., Zhang, H. and Zhu, Y., 2013. Progress in thermal comfort research over the last twenty years. *Indoor Air*, 23(6), pp 442-461.

Ding Y., Tian Z., et al, 2011. Achievements and suggestions of heat metering and energy efficiency retrofit for existing residential buildings in northern heating regions of China. *Energy Policy*, 39 (9), pp. 4675-4682.

Fanger, P.O., 1970. *Thermal comfort. Analysis and application in environmental engineering*. Copenhagen: Danish Technology Press.

Fanger, P.O. and Toftum, J., 2002. Extension of the PMV model to non-air-conditioned buildings in warm climates. *Energy and Buildings*, 34(6) pp 533-536.

Fato, I., Martellotta, F., et al, 2004. Thermal comfort in the climatic conditions of Southern Italy, *ASHRAE Transactions*, 110 (2), pp 578-593.

Goto, T., Mitamura, T., Yoshino, H. et al., 2007. Long-term field survey on thermal adaptation in office buildings in Japan. *Building and Environment*, 42(12), pp 3933-3954.

GB/T, 2012. *Evaluation Standard for Indoor Thermal Environment in Civil Buildings, GB/T 50785*. Beijing: Ministry of Housing and Urban-Rural Development of the People's Republic of China. (In Chinese).

Humphreys, M.A., Nicol, J.F., 1998. Understanding the adaptive approach to thermal comfort. *ASHRAE Transactions*, 104 (1), pp 991-1004.

Halawa, E., Van Hoof, J., 2012. The adaptive approach to thermal comfort: A critical overview. *Energy and Buildings*, 51, pp 101-110.

Karyono, T.H., 2000. Reporting on thermal comfort and building energy studies in Jakarta- Indonesia. *Building and Environment*, 35 (1), pp 77-90.

Luo, M., Cao, B., et al, 2014. Can personal control influence human thermal comfort? A field study in residential buildings in China in winter. *Energy and Buildings*, 72, pp 411-418.

Nicol, J.F. and Humphreys, M.A., 2002. Adaptive thermal comfort and sustainable thermal standards for buildings. *Energy and Buildings*, 34 (6), pp 563-572.

Nicol, F. and Humphreys, M., 2010. Derivation of the adaptive equations for thermal comfort in free-running buildings in European standard EN 15251. *Building and Environment*, 45 (1), pp 11-17.

Nikolopoulou, M. and Steemers, K., 2003. Thermal comfort and psychological adaptation as a guide for designing urban spaces. *Energy and buildings*, 35(1), pp 95-101.

Schweiker, M., Brasche, S., et al, 2012. Development and validation of a methodology to challenge the adaptive comfort model. *Building and Environment*, 49, pp 336-347.

Schweiker, M., Brasche, S., et al, 2013. Explaining the individual processes leading to adaptive comfort: Exploring physiological, behavioral and psychological reactions to thermal stimuli. *Journal of Building Physics*, 36(4), pp 438-463.

Yao, R., Li, B., Liu, J., 2009. A theoretical adaptive model of thermal comfort-Adaptive Predicted Mean Vote (aPMV). *Building and Environment*, 44 (10), pp 2089-2096.

Yu, J., Ouyang, Q., Zhu, Y.X., et al, 2012. A comparison of the thermal adaptability of people accustomed to air-conditioned environments and naturally ventilated environments. *Indoor Air*, 22(2), pp 110-118.

Zhang, Y., Wang, J., Cheng, H., Zhang, J. and Meng, Q., 2010. Thermal comfort in naturally ventilated buildings in hot-humid area of China. *Building and Environment*, 45(11) pp 2561-2570.

Zhang, Y., Chen, H. and Meng, Q., 2013. Thermal comfort in buildings with split air-conditioners in hot-humid area of China. *Building and Environment*, 64, pp 213-224

Zhou, X., Ouyang, Q., Zhu, Y.X., et al, 2013. Experimental study of the influence of anticipated control on human thermal sensation and thermal comfort. *Indoor Air*, Doi: 10.1111/ina.12067.

Thermal judgements and adaptive behaviours: a study on the subjective side of thermal comfort in two University buildings in France.

Margot Pellegrino¹

1 LEESU- GU, University of Paris-Est Marne-la-Vallée margot.pellegrino@u-pem.fr

Abstract

This paper presents some of the results of a field study carried out in 2013 in two University buildings in Paris and in Champs-sur-Marne, nearby Paris. The aim of the study was to examine students' thermal judgements and thermal adaptation by combining an objective and a subjective approach. First is presented a comparison between "real" thermal responses (thermal sensation, preference, acceptability) and predicted ones (Predicted Mean Vote, Predicted Percentage of Dissatisfied), after which follows an analysis of students' actions to improve their thermal comfort. Results reveal the significance of looking at thermal comfort in naturalistic settings. They also invite to address thermal responses, behaviours and opinions in an integrated protocol based on rich information on the "subjective side" of thermal comfort.

Keywords: thermal judgements, adaptive comfort, practices and behaviours, subjective and objective approach.

1. Introduction

The first codified methodology for determining thermal comfort range was introduced by Fanger (Fanger, 1972), with the support of ASHRAE (American Society of Heating, Refrigerating and Air-Conditioning Engineers). Fanger constructed from a fully controlled climate chamber a comfort index (PMV) expressed in an equation. This index is accurately calculable in any geographical context, and it suits very well fully conditioned and mechanically ventilated buildings. Numerous studies since 1970 have shown that this model is not able to properly assess the human response in naturally ventilated buildings. Models developed around the concept of Adaptive Comfort are implemented on the assumption that persons play an active role in determining their own conditions of comfort, instead of suffering passively the surrounding environmental conditions (Humphreys and Nicol, 1998; Brager and de Dear, 1998). A model developed by Dear and Brager (de Dear and Brager, 2002) from the international database ASHRAE proposes a new algorithm for predicting thermal comfort that relates the internal temperature of comfort to the average outdoor temperature. A similar model has been developed by the European project SCAT and integrated in the standard EN 15251 (Nicol and Humphreys, 2010).

Following the Adaptive Comfort principles, we attempt in this paper to approach the "subjective side" of thermal comfort in two University buildings, thus focusing on personal thermal judgments and adaptive behaviours in this important context.

2. Aims of the study

This paper presents some results of a field study carried out in 2013 in two University buildings in Paris and in Champs-sur-Marne, nearby Paris. The aim of the study was to investigate thermal sensation, thermal adaptation and thermal representation of university students by means of both an objective and a subjective approach.

A large amount of data was collected; this paper presents a part of the results. Two are the topics addressed by this paper. The first one focuses on the comparison between actually measured thermal responses (from data collected during the surveys, i.e. thermal sensation, preference, acceptability) and hypothesized/deduced ones (Predicted Mean Vote, Predicted Percentage of Dissatisfied). This comparison is carried out by the means of different thermal scales used in a questionnaire that was submitted to a number of students. It was decided not to focus on the direct correlation between votes and environmental data, such as temperature humidity etc., and that is the reason why calculation of neutral temperature is not presented in this paper. The objective here is to better understand the relation between thermal sensation, preference and acceptability, evaluating at the same time the correspondence between collected and measured votes on thermal comfort.

The second topic addressed in this paper concerns thermal adaptation. By “thermal adaptation” we mean in this context a set of actions that the surveyed subjects perform to improve their thermal comfort. We explored the opinions on the effectiveness of those practices, since one of the aims was to examine the students’ ability to evaluate the adaptation opportunities that classrooms afford. We tried to understand their aptitude for carrying out different activities with a thermal implication (opening a window, drinking, etc). Finally, we wanted to see if any link could be found between students’ thermal responses (sensation, preference etc.) and their degree of thermal adaptability measured through the implementation of those practices.

3. Context

3.1 Buildings

Two university buildings were surveyed. The first one (EVS) is the Architecture School in Paris-Val de Seine (Figure 1a and 1b). It’s a seven storey building recently edified (2007) by F. Borel, Grand National Prize for Architecture 2010. His *silhouette* faces the Seine River in the 13th department of Paris, participating in the renovation of the ancient industrial neighborhood. The school welcomes over 1.800 students, 230 teachers and 70 administrative staff. Since the purpose of the study was the investigation of students’ thermal comfort conditions, the choice was made to focus on three different classrooms. The first one is an amphitheatre (Amphi), located at the 1st floor, East-oriented, mechanically ventilated and equipped with a ceiling air-heating system. Some very small windows are located at the highest position of the wall, and students cannot either reach or open them. Windows are permanently covered by internal black curtains. The second and the third ones are two rooms that are similar in size, use and equipment. They are naturally ventilated and air-heated. One (room 411) is located at the 4th floor, North facing; while the other one (room 504) is located on the 5th floor and is West-oriented. No curtain or shading system is installed. The second university building (UPEM) is called Lavoisier and it is part of the Marne-la-Vallée university campus in Champs-sur-Marne, close to Paris (Figure 1.c). Built in 1993 by architects F.-H. Jourda and G. Perraudin, the building is a totally glazed and squared volume. One classroom was chosen (room 211) on the first floor, South facing, naturally ventilated and heated by wall radiators.



Figure 1a, b: North and East view of EVS. Figure 1.c : UPEM building

3.2 Subjects

A total of 183 students participated in the surveys. Table 1 specifies the sample size, age, weight and height for the different classrooms and buildings. Similar characteristics can be found concerning age, weight and height, whereas gender is inverted from EVS (female majority) to UPEM (male majority)

Table 1. Summary of sample

Place	EVS				UPEM	ALL
	All	Amphi	411	504	211	
<i>Sample size</i>	146	37	68	41	37	183
<i>Gender</i>						
Female	91	28	37	26	10	101
Male	50	7	29	14	22	72
<i>Age (years)</i>						
Mean	22,7	25,7	21,2	22,43	22,2	22,6
S.D.	4,33	6,8	1,32	3,5	1,71	3,9
Min.	19	21	19	20	20	19
Max.	52	52	26	40	28	52
<i>Weight (kg)</i>						
Mean	63,2	62,3	64,1	62,6	65,8	63,7
S.D.	11,7	9,4	12,4	12,6	8,9	11,3
Min.	43	43	45	44	48,5	43
Max.	90	85	90	90	80	90
<i>Height (cm)</i>						
Mean	170,7	169,3	171,8	170	174,6	171,4
S.D.	10,36	8	10,4	12,2	9,3	10,3
Min.	120	153	151	120	157	120
Max.	194	185	194	191	190	194

3.3 Climate

Paris has a mild humid temperate climate with warm summers and no dry season. Located in the western side of Europe and in a plain relatively close to the sea, Paris benefits from the balmy influences of the Gulf Stream. However, the weather can be very changeable especially in winter and spring, when the wind can be sharp and cold. Over the course of a year, the temperature typically varies from 1°C to 25°C and is rarely below -5°C or above

31°C. The annual average temperature is in the lower 12 °C; the July average is in the upper 19 °C, and the January average is in the upper 3 °C.

4. Methods and survey presentation.

Surveys were carried out during 2013 at different periods of the year. For EVS, 7 days of field work were organized from the 7th of March to the 16th of May 2013. UPEM students participated in the surveys 5 times from the 3rd of October to the 4th of December 2013. Students were expected to be questioned twice a day, at the beginning and at the end of the lesson during the regular lesson time, i.e. in the morning or in the first part of the afternoon (before 5 pm).

As suggested above, the present paper addresses the specific topics of thermal responses and thermal adaptation. However, the survey protocol is presented in what follows in its entirety, in order to give a more complete idea of the structure of the study. The aim of investigating thermal comfort inside university classrooms led us to set up a protocol based both on an objective and a subjective approach, starting from the hypothesis that the two are complementary and necessary for a deeper understanding of thermal comfort.

4.1 The subjective approach

The subjective approach was mainly intended to provide three different sets of information. The first one concerned the subjective thermal responses, i.e. judgements about the thermal sensation, perception, preference and acceptability of the environment. The second one focused on behaviours and practices and the third one on social representations. They were investigated through a questionnaire that was delivered and filled by the students while measurements (see 4.2) proceeded simultaneously. All efforts were put in trying to capture a “realistic” moment in the scholar daytime, neither breaking the situation continuity nor requiring any additional time, but attempting, with the help of the faculty, to integrate the task with the other usual tasks of the day (Corgnati et al., 2007). The questionnaire was devised on the basis of the author’s previous experiences (Pellegrino, 2012) and it was furthermore inspired by other literature (Indraganti, 2010; Wong, 2003; Kwok, 2003; Raja et al., 2001).. It was divided in different sections, some of them being fixed, and thus repeated at each step of the survey, which means at least once a day for the 13 days of survey, others being proposed only once.

- Fixed sections:

- a. Thermal comfort judgements. 10 evaluation scales were proposed, enquiring how the thermal environment was felt. The seven-points ASHRAE scale was the first one (ASHRAE, 2005), based on the identification of the thermal sensation votes (TSV ASHRAE) answering to the question “What is your thermal sensation now?” using a scale going from “cold” (-3) to “hot”(3). The second one was the seven-points Bedford scale (TSV Bedford) answering again to the previous question but using a scale going from “much too cool” (-3) to “much too warm” (3). The third one was a seven-points perception scale (TPER) intended to measure the personal opinion on the environment climate. As much as one could ask, walking outside, “what’s the weather like today?”, we asked for an indoor condition such as the one in the classrooms “how could you describe the indoor climate conditions now?”. Answers were the same as in the ASHRAE scale. The fourth (Nicol and Humphreys) (TP1) and the fifth (McIntyre) (TP2) scales concerned thermal preferences, asking “At the moment, would you prefer to feel...” and answering, for the Nicol one, using a five-points scale going from “much warmer”(-2) to “much cooler” (2), and for the McIntyre one, using a three-points scale from “warmer” (-1) to “cooler” (1). The sixth scale is a three-points

acceptability scale (TA), asking “At the moment, do you consider the thermal environment...” and answering “acceptable”, “slightly unacceptable” and “unacceptable”. The last four scales concern the evaluation, on a seven-points scale, of air speed and flow and humidity, in both cases asking an opinion about the intensity of those phenomena (AV; HV) and a personal preference (“Would you prefer...”, “no change”, “less humidity”, “more air”, etc) (AP; HP).

- b. Weather and clothes. Some questions were introduced in order to investigate the subjective perception of the weather the day of the survey and the day before. Seven symbols (sun, more sun than shadows, more shadow than sun, variable with rain, shadow, rainy, snowing) were reproduced on the sheets. For another question, students were requested to guess how many degrees there were in the room. And they had to describe how they were dressed (in order to calculate CLO value for PMV, ASHRAE, 2009); but they also had to report if their choice was determined by the weather and, if so, by which specific condition (temperature, wind, rain, other).
- Questions introduced only once in the surveys.
 - a. General information. “Classic” questions concerning name and surname, gender, age, weight and height of the subjects.
 - b. General judgements. Students were asked to give a general description of the indoor environment of the classrooms both in winter and summer using two seven points scales going from “always too hot” to “never too hot” and from “always too cold” to “never too cold”. They also had to provide an evaluation in terms of general quality (from “excellent” to “very bad”). Some other questions concerned the amount of time spent in A/C environments (in the car, in their house, in other houses and in the *loisir* spaces). Finally, they were asked to describe their subjective “approach” to climate, having to tell if they considered themselves a sensitive-to-cold person, a sensitive-to-hot person, an insensitive-to-climate person or someone who is very sensitive to both cold, hot and, in general, to all weather phenomena.
 - c. Behaviour and actions. One question was introduced asking to describe the activities performed in the previous 30 minutes. These data allowed to estimate MET value on the basis of the ASHRAE parameters (ASHRAE, 2009). They were used to calculate PMV at the beginning of the lesson; we used a fixed value of 1,3 MET to calculate PMV at the end, assuming a similar metabolic condition for all the students already sitting and listening to the lesson since at least one hour. Then a list of actions (“Modify the position of louvers, curtains, etc”, “Regulate the heating systems”, “Regulate the AC”, “Open and close a window”, “Open and close a door”, “Put or remove clothes”, “Drink”, “Have an air flow”) was made. For each of these actions, students were asked to describe: i) a “possibility” evaluation, telling if such an action was possible to be carried out, impossible, or possible only in the timeframe between two lessons; ii) an “effectiveness” evaluation, telling if an action was deemed to be effective to improve the thermal comfort in the classroom, ineffective, or effective but only on a long period; iii) a “direct” activities description, telling which or whose actions were directly carried out by themselves (“never carried out”, “carried out, but not today”, “carried out, today too”). This last question concerning “practical” observations was proposed at each step of the survey.
 - d. Social representations. The subjective approach was completed by a series of questions concerning social representations of comfort, thermal comfort and thermal adaptability. The term “social representation” was originally proposed by S. Moscovici (Moscovici, 1973). Recent developments of the original theory, known as *Central Nucleus Theory* (CNT) (Abric, 1994), led to explore the structural elements of

social representations, distinguishing between *core* and *peripheral* elements in terms of the centrality and stability of certain beliefs.

4.2 The objective approach.

The purpose here was to collect a dataset about the context of the survey. We focused on building and classroom characteristics, such as typology, orientation, exposition, number of floors, materials, heating and cooling systems, thickness of walls, double glazing, shading systems, openings dimension and position, presence of balcony.

Concerning weather conditions, we collected from the Météo France database a series of data on temperature in order to calculate the running outdoor mean temperature for the 30 and for the 3 previous days of each survey, and the mean temperature for the previous 24 hours (table 3).

The thermal environment of the four classrooms was analysed by means of field measurements campaigns carried out simultaneously with the questionnaires. Air temperature (T), globe temperature (T_g), air relative humidity (RH) and air velocity (Av) were measured (table 2) with the Sper Scientific WBGT SD Card Datalogger and the Testo 405 Anemometer at a height of 1.1 m above the floor, according to the Standard ISO 7726:1998 [10]. The instruments remained stationary in the classrooms for the duration of the survey.

Table 2. Summary of indoor and outdoor climatic data

Place	ALL				EVS				EVS Amphi				EVS 411				EVS 504				UPEM			
	Mean	S.D.	Min.	Max.	Mean	S.D.	Min.	Max.	Mean	S.D.	Min.	Max.	Mean	S.D.	Min.	Max.	Mean	S.D.	Min.	Max.	Mean	S.D.	Min.	Max.
Indoor air temperature °C	24	1,5	20,5	25,7	23	1,6	20,5	25,7	22	0,5	20,5	22,1	24	1,5	20,9	25,7	24	0,9	20,9	25,7	24	1,1	22	25,7
Indoor relative humidity %	36	12,1	18,8	63,2	30	9,1	18,8	48,7	34	10,6	24,1	48,7	27	6,6	18,8	40,8	29	7,6	18,8	42,5	46	9,8	31,5	63,2
Indoor globe temperature °C	23	1,7	19,6	26	23	1,9	19,6	26	21	0,7	19,6	22	24	1,7	20,4	26	24	1,2	20,4	26	24	0,9	22,1	25,6
Indoor air speed m/s	0	0	0	0	0	0	0	0	0	0	0	0	0	0	0	0	0	0	0	0	0,1	0,1	0	0,4
Running outdoor mean temperature (30 days) °C	8,8	4,7	4,1	17	7,2	3,5	4,1	14,6	5,5	0,9	4,1	6,7	8,2	3,8	4,1	14,6	8,2	4,2	4,1	14,6	11	5,2	5	17
Running outdoor mean temperature (3 days) °C	8,1	6	-0,7	18,4	6,9	5,9	-0,7	18,4	5,9	4,9	-0,7	12	7,6	7	-0,7	18,4	7,1	5,6	-0,7	18,4	10	5,5	2,8	16,7
Mean outdoor temperature (24 hours) °C	9,5	5,19	3	18	9,7	5,1	3	17,4	6,9	4,25	3	12,3	9,6	6,02	3	17,4	8,9	5,94	4	17,4	9,2	5,95	3,6	18

5. Results and discussion

5.1 Subjective thermal responses

Analyzing the comfort votes obtained via the previously quoted scales can help understanding thermal sensation, preference, neutrality and acceptability of the surveyed population, along with the evaluation of air velocity and humidity. Before starting these analyses, we compared the answers on scales through simple regression in order to get the determination coefficients that explain the correlations fit (I don't understand this subordinate). The results are shown in table 3. Colour intensity is proportional to correlation strength. The best correlations ($R^2 > 0.6$) were found between TSV ASHRAE scale and

Bedford and Thermal perception (TPER) scales, and between the two Thermal preference scales TP1 and TP2. Good correlations ($0.4 < R^2 < 0.55$) were found between TSV ASHRAE scale, TP1 and TP2; between Bedford scale, TP1 and TP2; between TPER and TP1; and between HV and HP. Modest correlations ($0.15 < R^2 < 0.35$) were found between Bedford, TP1, TP2, AV and AP. The same procedure was applied for the EVS and the UPEM sub-populations (table 4) for the relevant correlations. Results show that R^2 is always better for EVS population, with the only exception of the HP/HV correlation.

It may be recalled that students were requested to use thermal scales twice a day, at the beginning and at the end of the lesson. Or, perception of thermal conditions is known to be influenced by various factors such as activity, clothes, etc. which is the reason why we run a last series of correlations for every room for T (votes at the beginning) and for T+1 (votes at the end of the lesson). In most all of the cases, correlations between scales at T+1 were better than at T. This may be due to the stabilization of contour conditions, i.e. metabolism, leading to a more coherent evaluation of thermal responses by subjects.

Table 3. Simple regression between scales.

Table 4. Simple regression between scales for the EVS (in red) and the UPEM (in blue) populations

R^2	TSV ASHRAE	TSV Bedford	TPER	TP1	TP2	TA	AV	AP	HV	HP	PMV
TSV ASHRAE	1	0,6	0,6	0,4	0,4	0	0,1	0,2	0	0	0
TSV Bedford	0,6	1	0,5	0,4	0,4	0	0,1	0,2	0	0	0
TPER	0,6	0,5	1	0,4	0,3	0	0,4	0,2	0	0	0
TP1	0,4	0,4	0,4	1	0,8	0	0	0,3	0	0	0
TP2	0,4	0,4	0,3	0,8	1	0	0	0,3	0	0	0
TA	0	0	0	0	0	1	0	0	0	0	0
AV	0,1	0,1	0,4	0	0	0	1	0,2	0	0	0
AP	0,2	0,2	0,2	0,3	0,3	0	0,2	1	0	0	0
HV	0	0	0	0	0	0	0	0	1	0,4	0
HP	0	0	0	0	0	0	0	0	0,4	1	0

R^2	TSV ASHRAE	TSV Bedford	TPER	TP1	TP2	TA	AV	AP	HV	HP	PMV
TSV ASHRAE	1	0,7	0,7	0,5	0,5						
TSV Bedford	0,6	1	0,6	0,5	0,4			0,4			
TPER	0,6	0,5	1	0,5	0,4						
TP1	0,3	0,4	0,3	1	0,8			0,4			
TP2	0,4	0,4	0,3	0,7	1			0,3			
TA						1					
AV							1				
AP		0,1		0,2	0,2			1			
HV									1	0,4	
HP									0,5	1	

In the next analyses we will focus on thermal responses collected during the survey, and specifically on TSV ASHRAE, TP2 and TA scales. Figures 2, 3 and 4 show the frequency distribution of votes for the total population, the EVS population in Amphitheatre, the EVS population in rooms 411-504 (considered together for their similarities in floor area, openings and heating and ventilation systems) and the UPEM population. The TSV variable was reorganized in three classes (-3, -2; -1, 0; 1; 2, 3), assuming, as the ASHRAE Standards does, that the three central votes (-1, 0, 1) express acceptance and that votes outside this range express dissatisfaction.

Figures 2, 3, 4. Frequency distributions of TSV, TA and TP2 votes

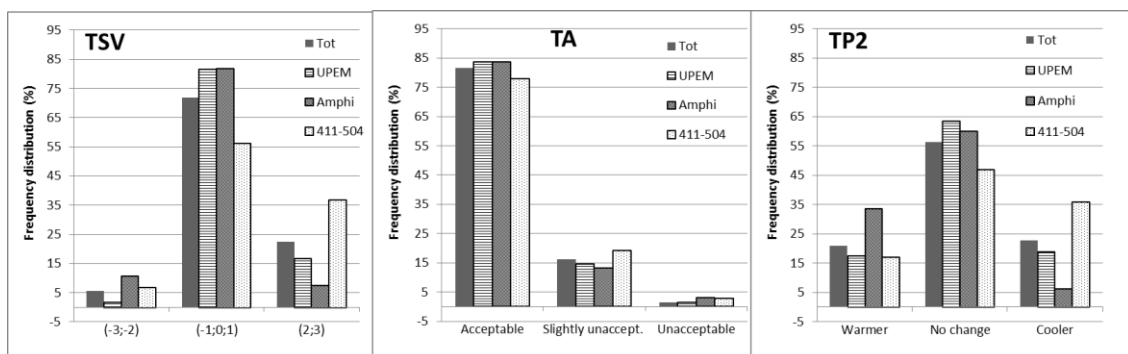

Some remarks can be made. First, focusing on the total population, it can be seen that in every scale the majority of votes centered on 0, i.e. on the central class for TSV, on “acceptable” class for TA and on “no change” class for TP2. Second, looking at the samples separately, some differences can be found both in scale and population comparison. It is possible to observe that, in TA scale, populations reacted very similarly. All values are aligned, with the exception of the population of rooms 411-504, where the environment was found to be slightly unacceptable by 19.2%, as against the total value of 16.1% and the lowest value of 13.3% (Amphi). The situation is clearly different if we consider the votes on TSV and TP2, where variances between populations are significant. In TSV, in the central class, there is a difference of 25.5% between the highest values (UPEM and Amphi) and the lowest ones (rooms 411-504). This affects the (2, 3) class values, where the gap is even wider (29.3%). In the TP2 scale it can be observed for the “no change” class the same situation as in TSV, with UPEM and Amphi values higher than the 411-505 ones. But when we focus on the external classes, we can see that while UPEM votes are symmetrically distributed (nearly the same percentage of population votes “wanting warmer” and “wanting cooler”), Amphi population voted mostly “wanting warmer” (33.5% against 6.3%) and the 411-504 population mostly votes “wanting cooler” (17.1% against 36%). This last result is coherent with the high percentage (36.8%) of 411-504 individuals voting “warm” and “hot” (2, 3) in TSV scale.

Previous scales showed the “real” votes of the surveyed populations. But thermal votes can also be predicted following a specific method. In Figures 5 and 6, PMV (Predicted Mean Vote) and PPD (Predicted Percentage of Dissatisfied) values are shown. These parameters were calculated starting from measured data (T, RH, Top, Av) and subjective data on clothes and metabolism according to the ASHRAE Standard (ASHRAE, 2009). PMV was organised in three classes, while PPD values were split in two classes, one grouping all the values lower than 20% and the other gathering all the upper values. This was done according to ASHRAE Standard 55-2009 prescriptions, using the PMV model to set the requirements for indoor thermal conditions so as to ensure satisfaction of at least 80% of the occupants.

If we compare those graphs with the previous ones we note a striking difference, namely the highest percentage of votes for 411-504 population in the central PMV class and in “satisfied” class of PPD, while we previously observed that votes for this population were always lower than the others. In the (>1) PMV class, 411-504 population only has 1.9% of votes, while in the (2, 3) TSV class it has 36.8% of votes. Similarly, 24.5% of Amphi population votes belong in the (<-1) PMV class, while 10.7% votes are included in the (-2, -3) TSV class.

Figures 5, 6. Frequency distribution of PMV and PDD

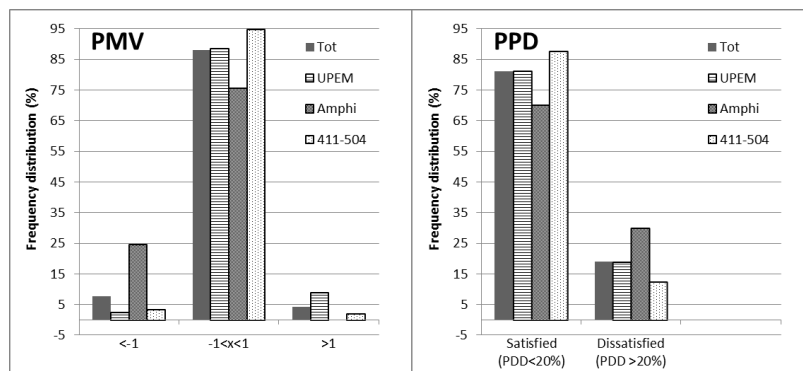

To summarize and better compare thermal acceptability we plotted on Figure 7 the correspondent classes of all the proposed scales and votes, i.e. “acceptable” and “acceptable” + “slightly unacceptable” for TA, (-1, 0, 1) for TSV, “no change” for TP2 and (<20%) for

PPD. Highest frequency distribution can be observed for both the TA classifications, where values nearly reach 100% in the first case and 81.5% in the second case. Results are homogeneous for all the populations. Ranking the frequency distributions for the total population, PPD follows (81.1%); then come TSV (71.8%) and TP2 (56.4%). TP2 shows the lowest values for all the population, with votes of 411-504 students on “no change” approach 50%, while they reach 94.8% in the PPD scale.

Figure 7. Comparing various methods of acceptability

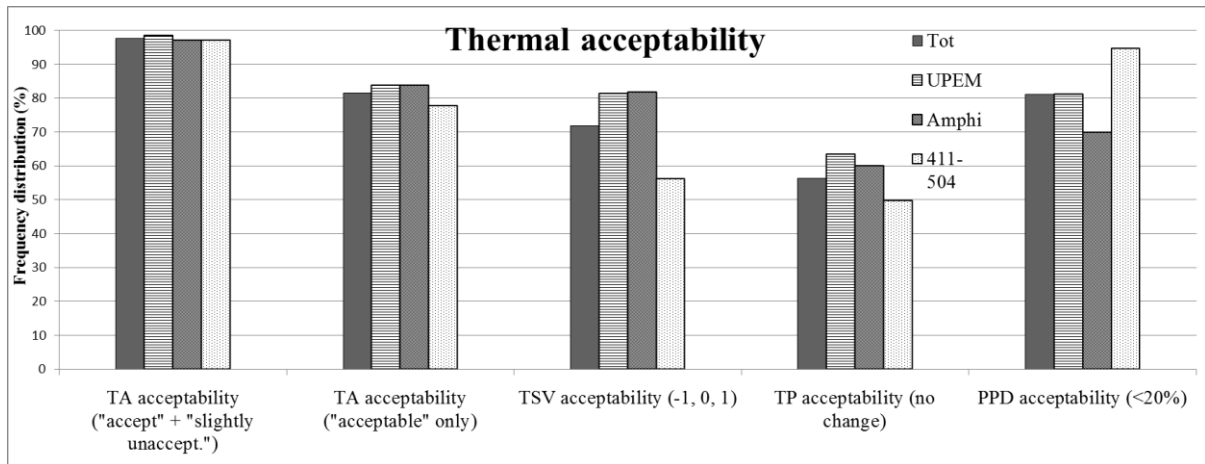

The previous analyses focus mainly on thermal acceptability. The results call for a deeper comparison in order to better understand vote distribution on different scales. That is the reason why we plotted TP1 and PMV votes on TSV for the total and the split populations (Figures 8 to 15). Concerning TP2, it can be seen that 15.5% of individuals voting in the central TSV class chose “wanting warmer” in the TP2 scale, and 9% voted “wanting cooler”. In Amphi this tendency is still more apparent, since 23.6% of individuals voting in the central TSV class chose “wanting warmer” in the TP2 scale (but only 4.5% chose “wanting cooler”). In rooms 411-504 10.5% of individuals voting in the central TSV class chose “wanting warmer” in the TP2 scale and 10.5% chose “wanting cooler”. Furthermore, in this population there is a 10.9% voting in (2, 3) TSV class that chose “no change” in the TP2 scale. In UPEM, more than 55% of individuals voting in the central TSV class chose “no change” on TP2 scale, which is the highest value overall; 16.1% chose “wanting warmer” and 9.7% chose “wanting cooler”.

Figure 8 to 11. Diagrams of cross-tabulation, TP2 plotted on TSV

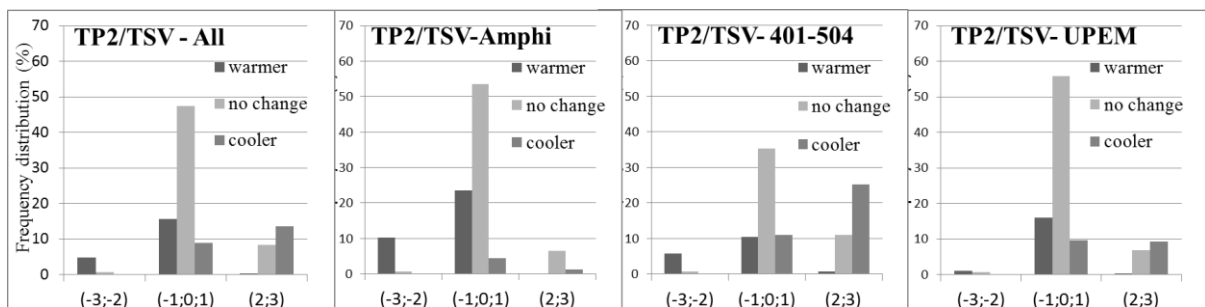

Plotting PMV on TSV similar remarks can be made, appeasing the conflict between “real”, measured votes and predicted ones. Regarding the total population, we can observe that 21.1% of individuals voting (2, 3) on TSV scales has a predicted mean vote that lies in the central

PMV class ($-1 < 0 < 1$), a percentage that becomes 35.4% for the 411-504 population. For the case of Amphi population, 20.1% of individuals voting $(-1, 0, 1)$ in the TSV scale has a predicted mean vote that lies in the (>1) PMV class.

Figure 12 to 15. Diagrams of cross-tabulation, PMV plotted on TSV

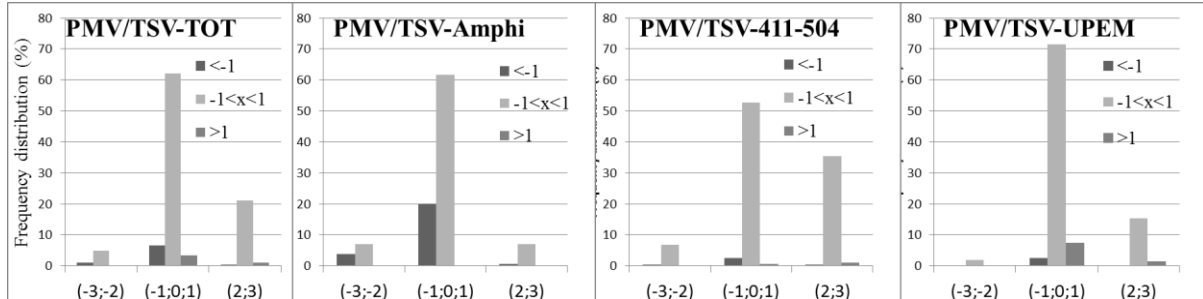

For each population Figures 16 and 17 show the mean PMV, PPD, globe temperature, clothing resistance and TSV, associated with the frequency distribution of thermal preference (TP2) and thermal acceptability (TA).

Figure 16 and 17. Percentage of preference (16) and acceptability (17) vs mean of PMV, PPD, Tg, CLO and TSV for each classroom.

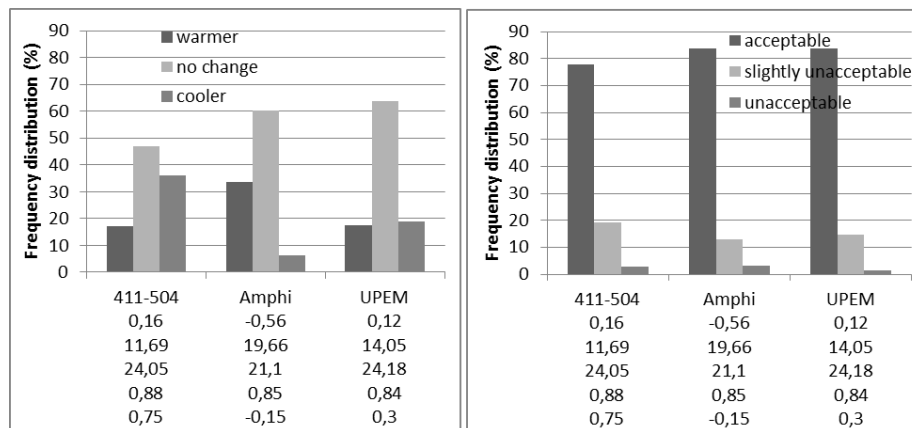

5.2 Practices and behaviours

As previously explained (see 4.1), a list of actions (“Modify the position of louvers, curtains, etc”, “Regulate the heating systems”, “Regulate the AC”, “Open and close a window”, “Open and close a door”, “Put or remove clothes”, “Drink”, “Have an air flow”) was made and students were requested to provide three descriptions regarding the following aspects.

The first one was a “possibility” evaluation, telling whether the action was deemed to be possible, impossible, or possible only in the interval between two lessons. Through this question we sought to apprehend what level of “knowledge” of the surrounding space students had, and the actions with a view to improving their thermal comfort (and maybe reduce an uncomfortable sensation) they considered possible or impossible during a lesson. In order to analyze the data, we identified different patterns or groups on the basis of similar answers, and we “typified” each group with an allusive designation.

Table 5 summarizes the results. We can identify a first group of individuals, that we can call “misunderstanders”. For example, something intriguing could be found looking at the Amphi

percentage of answers to the questions “Modify the position of louvers, curtains, etc”, and “Open and close a window”, namely a 20% and a 40% on “possible”, respectively. In this space windows and curtains are in the upper portion of the wall and students cannot reach them. Now in general windows can be opened and curtains moved, but in fact nobody can accomplish this operation without a staircase or a particular instrument. Back in the Amphi, 44% thinks that the heating system can be regulated - but it is an air-heating system, on which students do not have any control. The precise formulation of the question was: “Among the following actions, which ones are possible in this classroom?”. This is probably a drawback of the survey that led to some misunderstandings. Indeed, it was not clear to respondents *for whom* these actions were possible. The heating system can obviously regulated by somebody, namely the technical staff. Hence, we can speculate that students’ answers generally referred more to an abstract possibility than to a concrete here-and-now possibility. On that assumption, the corresponding answers are not reliable.

A second group can be identified that we shall call the “*distracted*”. It is a mixed group, composed by members of the three populations. For example, 17.2% of 411-504 students said that it was possible to modify the position of louvers and curtains, and 20.3% that it was possible but not during the lesson. In this case misunderstanding is ruled out because no louver and no curtain can be found in these classrooms. Similarly, 14.1% and 32% of 411-504 and Amphi, respectively, reported that it was possible to control the AC, and yet the AC is not installed. Finally, 63.6% of UPEM students answered that it was not possible to regulate the heating system, while operable radiators were as a matter of fact installed.

The third group includes the “*possibilists*”. For an action equally feasible for the three populations (e.g. in all the cases it was possible to open and close the door), we can see that a higher percentage of UPEM noticed the action opportunity as compared to the other populations . For example, 100% of UPEM population answered that it was possible to open and close the door, as compared to 81.3% and 80% of 411-504 and Amphi; 97% answered that it was possible to open and close the windows compared to 37.5% of 411-504; 93.9% answered that it was possible to put or remove clothes compared to 79.7% of 411-504 and 84% of Amphi; finally, 93.9% thought that it was possible to have an air flow compared to 64.1% and 40%. A fourth group, called the “*pessimists*”, is mainly composed by Amphi individuals, who frequently had the highest percentage of “not possible” answers, especially if compared to 411-504. A last group can be identified assembling the “*shies*”, mostly belonging to 411-504, who often had the highest percentage of “possible, but not during lessons” answers, with the exception of the “drink” answer, where UPEM featured the highest score.

Table 5. “Possibility” evaluation (%) for 411-504, Amphi and UPEM populations.

ACTIVITY	Possible			Not Possible			Not possible during lessons		
	411+504	Amphi	UPEM	411+504	Amphi	UPEM	411+504	Amphi	UPEM
Modify the position of louvers, etc	17,2	20	69,7	57,8	68	12,1	20,3	4	18,2
Open and close a door	81,3	80	100	7,8	16	0	6,3	4	0
Regulate the heating systems	39,1	44	15,2	42,2	52	63,6	12,5	4	21,2
Regulate the AC	14,1	32	0	70,3	68	97	12,5	0	3
Open and close a window	37,5	40	97	45,3	44	0	14,1	12	0
Put or remove clothes	79,7	84	93,9	6,3	12	0	6,3	0	6,1
Drink	78,1	76	69,7	9,4	16	12,1	7,8	8	15,2
Have an air flow	64,1	40	93,9	23,4	36	0	9,4	20	6,1

The second question asked to students concerned the “effectiveness” evaluation, in order to understand if an action was deemed to be effective to improve thermal comfort, ineffective, or effective but only on (for, in??) a long period. In this case, the question was not specifically referred to the classroom context, but to a general opinion of the subjects. The results are shown in table 6.

The most effective action is “put or remove clothes”, which is the only consensual one (the three percentages are above 80%). UPEM population, consistently with the “*possibilists*”, is characterized by high percentages of “effective” for many other answers: open and close the door, the window, have an air flow (all upper 85%); modify the position of louvers and drink (around 65%). In contrast, UPEM students have the lowest score on the effectiveness evaluation of the heating systems and the AC. Even if this question and the previous one are not directly related, this result may be explained by table 6, where it can be seen that they thought it was not possible to do those actions in their classroom. For the Amphi population the most effective actions are to put or remove clothes (91.3%), open and close a door, regulate the AC and regulate the heating system (around 65%-73%). For the 411-504 population, such actions are to put or remove clothes (80%), open and close a door or a window, and have an air flow (around 70-75%).

Table 6. “Effectiveness” evaluation (%) for 411-504, Amphi and UPEM populations.

ACTIVITY	Effective			Not effective			Effective, but it'll take time		
	411+504	Amphi	UPEM	411+504	Amphi	UPEM	411+504	Amphi	UPEM
Modify the position of louvers, etc	27,3	39,1	65,6	49,1	30,4	34,4	3,6	4,3	0
Open and close a door	72,7	65,2	90,6	20	21,7	9,4	1,8	8,7	0
Regulate the heating systems	58,2	73,9	50	25,5	8,7	43,8	1,8	8,7	0
Regulate the AC	52,7	65,2	43,8	16,4	13	50	1,8	13	0
Open and close a window	74,5	56,5	96,9	14,5	21,7	3,1	0	4,3	0
Put or remove clothes	80	91,3	96,9	12,7	0	0	1,8	0	0
Drink	63,6	60,9	65,6	27,3	21,7	31,3	0	0	0
Have an air flow	70,9	47,8	87,5	18,2	21,7	9,4	0	0	0

The last question concerned “direct” activities, describing which actions students directly performed in the classroom (“never carried out”, “carried out, but not today”, “carried out, also today”). This question was asked at each day of the survey. The data processing aimed to compare the answers and to assess their reliability. We analysed the “not, never” answers to test their consistency across questionnaires filled in different days. An acceptable consistency level was found; we proceeded by calculating the frequency of answers for all the days of the survey. A final result was obtained calculating the mean value. For “yes, but not today” and “yes, today too” answer we proceeded in a similar way, calculating a mean value of all the answers on different days (table 7). UPEM population is in general more “active” than the others, and Amphi is the less “active” one. Putting or removing clothes and drinking are the most practiced actions, followed by opening and closing a window. Some “never-carried-out” actions, such as regulating the AC, probably indicate that they are impossible. Again, AC is

not installed in classrooms. We can speculate that students were more “distracted” when they answered about possibilities (table 6), and answered without examining the real equipment. But in this case, since subjects had to think about their own actions and practices, their answers were more relevant, and, in an indirect way, they provide complementary information on space characteristics.

Table 7. “Direct” activities (%) for 411-504, Amphi and UPEM populations.

ACTIVITY	Not, never			Yes, but not today			Yes, today too		
	411+504	Amphi	UPEM	411+504	Amphi	UPEM	411+504	Amphi	UPEM
Modify the position of louvers, etc	61,1	92,9	21,9	38,9	7,1	71,9	0	0	6,3
Open and close a door	33,3	42,9	6,3	61,1	57,1	68,8	5,6	0	25
Regulate the heating systems	83,3	85,7	78,1	16,7	7,1	18,8	0	14,3	3,1
Regulate the AC	100	85,7	90,6	0	7,1	6,3	0	7,1	3,1
Open and close a window	11,1	78,6	0	72,2	14,3	75	16,7	0	25
Put or remove clothes	0	7,1	0	33,3	42,9	40,6	66,7	50	59,4
Drink	5,6	7,1	12,5	61,1	42,9	50	33,3	50	37,5
Have an air flow	33,3	64,3	12,5	66,7	35,7	65,6	0	0	21,9

6. Conclusion

In this paper we approached thermal comfort in classrooms by analyzing individuals’ thermal responses and adaptive practices. By focusing on personal sensations, perceptions, opinions and behaviours, we put individuals at the centre of the stage. In accordance with recent literature that has been developing an adaptive approach, the paper underscored the significance of examining thermal comfort within natural settings. It also claims that thermal research should address thermal responses, behaviours and opinions in an integrated protocol providing maximally exhaustive information on the “subjective side” of thermal comfort.

The key findings of the survey are as follows:

A) First part on thermal responses.

- When we consider frequency distributions, we can see that thermal scales lead to varied individual interpretations of comfort. In our case, thermal acceptability indicates a very high percentage of satisfaction, while thermal sensation and mainly thermal preference present lower values.

- When we map thermal preference votes on thermal sensation votes, they do not overlap. This suggests that neutral sensation is not always the preferred thermal state for the surveyed students.

- Predicted Mean Votes and Predicted Percentage of Dissatisfied show a very high percentage of satisfaction, which surpass the ones measured by thermal sensation and preference. In other words, in our case PMV and PPD underestimate subjective thermal dissatisfaction.

- PMV shows some amount of inconsistency with thermal sensations votes. Low agreement ratios can be observed when people voting (2, 3) on TSV are considered satisfied (calculated

votes in the central class). Similarly, some people voting in the central class (satisfied) on TSV are considered unsatisfied by PMV (<-1 class).

- When we consider the three populations in detail, it is possible to observe that thermal scales behave differently. Thermal acceptability shows similar values, while the other scales display consistent differences between comfort votes in the three places. It results that UPEM population is the most and 411-504 the less comfortable one. UPEM population is also the best distributed on TSV, with a similar percentage of (2, 3) and (-3, -2) votes. Those results are contradicted by PMV and PPD, regarding which the 411-504 population has the highest percentage of satisfaction.

B) Second part on thermal adaption.

- “*Possibilities*” question. Issues of reliability were discussed in this regard. Referring to the question on possibilities, a considerable part of the population (the “*distracted*” ones) gave a wrong answer, for example reporting that in the classroom it was possible to regulate the AC when the latter was in fact not even installed. Probably the students were not paying much attention while filling the questionnaire; but more generally, probably students do not pay much attention to “thermal” equipment such as AC, heating systems, curtains etc. either. We may speculate that they have limited interest in the environment or a weak inclination for observation.

- Apart from the “*misunderstanders*”, four other groups of students were identified: the “*distracted*”, the “*possibilists*” (mostly UPEM), the “*pessimists*” (mostly Amphi) and the “*shies*” (mostly 411-504).

- “*Effectiveness question*”. The most effective action is “putting or removing clothes”, which is the only one that is also consensual. The UPEM population is characterized by high percentages of “effective” answers. For Amphi population the most effective actions are putting or removing clothes, opening and closing a door, regulating the AC and regulating the heating system. For the 411-504 population, such actions are putting or removing clothes, opening and closing a door or a window and having an air flow.

- “*Direct activities*” question. Putting or removing clothes and drinking are the most practiced actions, followed by opening and closing a window. In general the UPEM population is more “active” than the other ones, whereas Amphi proves the less “active” one.

C) Crossing thermal responses and adaptation.

- Deeper analyses should examine if any correlation exists between thermal responses and adaptation. At this stage of the study, we can notice that the UPEM population (which turns out to be the most satisfied one on TSV, TA and TP2 scales) is also the one who has the highest percentages on “*possibilist*”, “*effective*” and “*direct activities*” answers. We think this is an encouraging result that calls for new studies on the “subjective side” of comfort analysis.

Bibliography

- Abric, J.C. (Ed). 1994. *Pratiques sociales et representations*. Paris: Presses Universitaires de France
- ASHRAE. 2005. *ASHRAE Handbook of Fundamentals*. Atlanta: American Society of Heating Refrigeration and Air-Conditioning Engineers Inc.
- ASHRAE. 2009. *ASHRAE Handbook of Fundamentals*. Atlanta: American Society of Heating Refrigeration and Air-Conditioning Engineers Inc.
- Baker, N., Standeven, M. 1996. Thermal comfort for free-running buildings. *Energy and Buildings*, vol. 23.

- Brager, G.S., de Dear, R. 1998. Thermal adaptation in the built environment: a literature review, *Energy and buildings*, vol. 27.
- Corgnati, P., Filippi, M., Viazzo, S. 2007. Perception of the thermal environment in high school and university classrooms: subjective preferences and thermal comfort. *Building and environment*, vol. 42.
- De Dear, R.J., Brager, G. S., & Cooper, D. 1997. Developing an Adaptive Model of Thermal Comfort and Preference, *ASHRAE RP- 884*.
- De Dear, R., Brager, G. 2002. Thermal comfort in naturally ventilated buildings: revisions to ASHRAE Standard 55, *Energy and Buildings*, vol. 34.
- Fanger, P. O. 1972. *Thermal Comfort, Analysis and Applications in Environmental Engineering*, NY: McGraw-Hill.
- Humphreys, M., Nicol, F. 2008. Adaptive Thermal comfort in Buildings, *Proceedings of the conference Air-conditioning and Sanitary Engineers of Japan*.
- Humphreys, M. A., Hancock, M. 2007. Do people like to feel 'neutral'? Exploring the variation of the desired thermal sensation on the ASHRAE scale, *Energy and buildings*, vol. 39
- Humphreys, M., Nicol, F. 1998. Understanding the adaptive approach to thermal comfort. *ASHRAE transactions*
- Indraganti, M. 2010. Thermal Adaption and impediments: Findings from a field study in Hyderabad, India, *Proceedings of NCEUB Windsor Conference*.
- Kwok, A.G., Chun, C. 2003. Thermal comfort in Japanese schools, *Solar Energy* n. 74.
- Moscovici, S. 1973. *Foreword*. In C. Herzlich (Ed.), *Health and illness: A social psychological analysis* (pp. ix–xiv). London/New York: Academic Press.
- Nicol, J. F. 1993. *Thermal comfort: A handbook for field studies toward an adaptive model*. London: University of East London.
- Nicol, J.F., Humphreys, M.A. 2002. Adaptive thermal comfort and sustainable thermal standards for buildings, *Energy and Buildings*, Vol. 34.
- Nicol, J.F., Humphreys, M.A. 2010. Derivation of the adaptive equations for thermal comfort in free-running buildings in European standard EN15251, *Building and Environment*, vol. 45.
- Nicol, J. F., Humphreys, M. A., Roaf, S., 2012, *Adaptive thermal comfort. Principles and practice*, Routledge, pp. 208.
- Pellegrino, M., Simonetti, M., Fournier, L., 2012, A field survey in Calcutta. Architectural issues, thermal comfort and adaptive mechanisms in hot humid climates, *Windsor conference, Network on Comfort and Energy Use in Buildings « The changing context of comfort in an unpredictable world »*
- Raja, I., Nicol, J. F., McCartney, K. J., & Humphreys, M. 2001. Thermal comfort: Use of controls in naturally ventilated buildings. *Energy and Buildings*, vol. 33.
- Rijal, H. B., Humphreys, M. A., & Nicol, F. J. 2009. Understanding occupant behaviour: the use of controls in mixed-mode office buildings. *Building Research & Information*, vol. 37
- Steemers, K., Manchanda, D. (2010). Energy efficient design and occupant well-being: Case studies in the UK and India, *Building and environment*, vol. 45.
- Thellier, F., Monchoux, F., Bedrune, J-P., 2012, Confort dans le bâtiment : n'oublions pas l'habitant ! *La revue 3E.I.*, vol. 69, pp. 24-32.
- Wong, N. Y., Khoo, S., S., 2003. Thermal comfort in classrooms in the tropics, *Energy and buildings*, vol. 35.
- Xiaojiang, Y., Zhaoxiao, Z., Zhiwei, L., Yuangao, W., Zhengping, Z., Chunxiao, J. 2006. Thermal Comfort of Neutral Ventilated Buildings in Different Cities, *Proceedings of the International Conference for Enhanced Building Operations, Shenzhen, China*.

Proceedings of 8th Windsor Conference: *Counting the Cost of Comfort in a changing world* Cumberland Lodge, Windsor, UK, 10-13 April 2014. London: Network for Comfort and Energy Use in Buildings, <http://nceub.org.uk>

User friendliness and building automation - A conceptual approach to understanding perceived control

Runa T. Hellwig

Augsburg University of Applied Sciences, Faculty of Architecture and Building; Unit E2D - Energy Efficiency Design, Building Climatology, An der Hochschule 1, 86161 Augsburg, Germany, email: runa.hellwig@hs-augsburg.de

Abstract

Building automation systems provide potential to optimise the energy consumption of buildings as well as to detect failures in the operation of buildings. Providing the occupants with control over the indoor environment is widely accepted to positively affect the occupant's satisfaction. The system building-HVAC-automation-user is becoming more complex. So what does the term 'perceived control' really mean? Psychological constructs from social learning theory and personality psychology transferred to the field of personal control of the indoor environment will be discussed. There are already several models describing man-environment interaction or the importance of control for persons. These models exist in parallel and have not been interconnected and translated into models for the built environment, yet. The aim of this paper is to show how these models could be interconnected and to develop a conceptual approach explaining the role individual control plays for user satisfaction.

Keywords: perceived control, adaptive opportunities, building automation, indoor environment, conceptual approach

1 Motivation and aim

Building automation systems are becoming more important. Today, technical facility management is hardly conceivable without building automation systems. The application of building automation systems provides potential to analyse and optimise the energy consumption of buildings as well as the detection of failures in the operation of buildings. Building automation has also been applied to control devices and systems conditioning the indoor environment at workplaces.

User friendliness or usability of a product is according to ISO 9241-11 (1998) generally defined as to depending on the context of the product usage. The context thereby includes the user with his experiences and expectations, the work task, work equipment, the physical environment, and the social environment. Three main criteria are used to assess the usability of a product: effectivity in solving a task or problem (task completion by users), efficiency in handling the system (task in time), and satisfaction of the user.

On the one hand, there is a potential to improve the user friendliness by the application of building automation systems. On the other hand, building automation is expected to offer more than just providing set points and automatic control algorithms in order to improve the indoor environmental conditions and the energy efficiency. The system building – HVAC – automation – user is becoming more complex. Operating real buildings with building automation systems shows that sometimes

occupants feel to be dominated by automatic systems. But to what degree should the indoor environmental conditioning systems be automated? In order to achieve a high percentage of occupants being satisfied with their workplaces, how should we design and configure building automation systems?

Although many studies investigating thermal comfort, sick building syndrome or user satisfaction in buildings found perceived control as to be a key variable we do not have a comprehensive understanding of the term 'perceived control'. The implementation of the adaptive model of thermal comfort into the European standard EN 15251 (2007) opened a discussion among building services manufacturers, engineers and designers of what adaptation or control really means.

Providing the occupants with control over the indoor environment is widely accepted to positively affect the occupant's satisfaction and has been used as an argument to increase the automation level accompanied with increasing the number of controls in a space. Some believe if there was the possibility for each person to freely adjust the environment or adjust to the environment by behaviour there would be no discomfort anymore.

Excellent work has been done and very useful recommendations and guidance of practical relevance has been provided by the work of Adrian Leaman and Bill Bordass from the Usable Buildings Trust in the UK (UBT several years).

Cabanac (e.g. 1996) first described the phenomenon of allesthesia which was recently revisited by de Dear (2011). Cabanac also described the role of pleasure and joy in thermal comfort. There are models explaining thermal adaptation (e.g. de Dear et al, 1998) or the impact of perceived control on thermal comfort (e.g. Nicol & Humphreys, 2002; Paciuk, 1990). There are general psychological approaches which could help to more comprehensively understand what perceived control could mean (Rotter, 1982; Bandura, 1997; Johnson, 1974). Environmental psychologists developed models explaining the interactions of organisms with their environment (e.g. Bell et. al 2001; Veitch & Arkkelin 1995).

All these models exist in parallel and have not been interconnected and translated into models for the built environment, yet. Boerstra et al. (2012) already discussed some of the above-mentioned models and summarised the key ingredients for a future model.

The aim of this paper is to show how these models could be interconnected and to develop a conceptual approach explaining the role individual control plays for user satisfaction. This approach could help to better understand what perceived control really means and then how we could design for high perceived control in buildings. On the basis of a literature review first the models from different fields of research are introduced and main results from studies investigated personal control will be summarised. Then, a new integrated conceptual approach, applied to the indoor environment in buildings will be presented.

2 Comfort, pleasure, and adaptation

Comfort is often defined as the subjective satisfaction with the thermal environment (ASHRAE Standard 55, 2010; ISO 7730, 1995). Cabanac (1996) explained why this definition is inadequate.

Cabanac (1996) founded the phenomenon of allesthesia. De Dear (2011) revisited this concept. Allesthesia describes the dependence of the sensation of a stimulus on the

subject's internal state. How a certain stimulus is perceived by the subject depends on whether the stimulus contributes to improve the internal state of the subject (positive, pleasant) or impairs the internal state of the subject (negative, unpleasant). As soon as the normal internal state of the subject is reached again, a positive stimulus turns to be unpleasant. Sensory pleasure is the pleasant sensation of a certain stimulus. Comfort is different from sensory pleasure. Comfort is the subjective indifference to the environment. Cabanac explained the different character of comfort and pleasure:

“A feeling of comfort indicates therefore that everything is right, but this is not a very exciting feeling, whereas pleasure indicates, in a troubled situation, a useful stimulus that should be consumed but will not last once the trouble is corrected”.

According to Cabanac, comfort is stable and can last whereas pleasure is transient. Pleasure serves to reward behaviour and to provide motivation to exercise behaviour beneficial for physiological processes. Subjective satisfaction with the thermal environment includes therefore indifference and pleasure. Cabanac explains that “...in the same way as there are two different elements in sensation [author's note: pleasure and comfort]...it is possible to recognise two elements in the affectivity of global consciousness: positive and transient joy, and indifferent but stable happiness.” Sensory pleasure is a strong motivator for behaviour suitable to restore homeostasis.

Adaptation is described by de Dear et al (1998) as to consist of three components: adjustment, habituation and expectation, and acclimatisation. Fig. 1 shows the behavioural feedback loop and the psychological feedback loop including the mediating or moderating effect of the built environment and the social environment (de Dear et al, 1997).

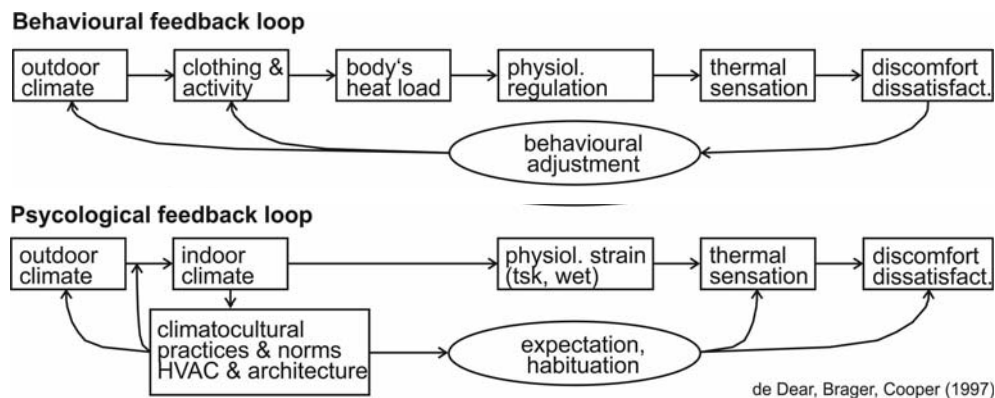

Figure 1. Adaptation to indoor climate: Behavioural and psychological feedback loops from de Dear et al (1997).

3 What does control mean to persons?

What control means to persons has been widely discussed in general psychological literature. General psychological approaches including control are mentioned in this paper merely to underline the importance control plays for humans and to show what a lack of control could induce in humans.

In the 1950ies Rotter (1982) developed his social learning theory. His main idea was that personality is a result of the interaction of the individual with his or her environment. To understand behaviour both the individual with its experiences and

the environment the individual is responding to and behaving in has to be considered. Rotter introduced the term ‘locus of control’ which is a concept of generalised expectancies for control of the behaviour outcome. A strong internal locus of control means people believe that they are responsible for the behaviour outcome by themselves, independently of success or failure. People with a strong external locus of control believe that the outcome of behaviour is controlled by luck, chance or powerful others.

In the 1970ies Bandura (1994) developed the theoretical construct of self-efficacy. Self-efficacy is a person’s belief in his or her capabilities to produce certain outcomes that exercise influence over events that affect his or her life. High self-efficacy is related to a person’s belief in his or her own competences. It influences the level of motivation, resilience to adversity and vulnerability to stress. Sources of self-efficacy include:

1. Mastery experience: Success in exercising behaviour (direct)
2. Vicarious experience: Seeing people similar to oneself manage task demands successfully (indirect)
3. Social persuasion: Verbally persuade people that one has the capabilities to succeed in given activities (symbolic)
4. Interferences from somatic and emotional arousal (sign for own competences)

Both, the construct of locus of control and the concept of self-efficacy and whether they mean more or less the same have been widely discussed. The attribution of an agent to an event is locus of control. Self-efficacy is seen as to be more related to the ability or skills of a person. Both concepts could be regarded as complementary.

The vicious cycle (Fig. 2) is according to rotter’s social learning theory a process which leads to confirmation of low expectations and can be regarded as a kind of self-fulfilling prophecy (Rotter, 1982). In case people have low expectations they do not believe their behaviours will be successful. Hence, they put only little effort into their behaviours. If they do not try to be successful they are likely to fail. The failure will confirm their low expectancies.

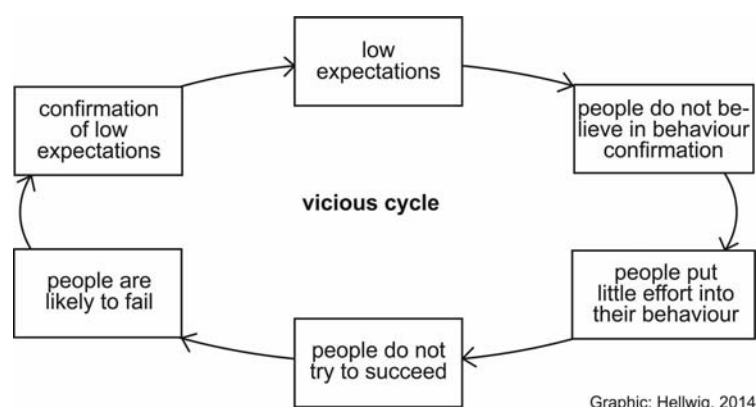

Figure 2. Vicious cycle according to Rotter’s social learning theory.

A comparable construct is that of learned helplessness developed by Seligman meaning that repeated efforts to regain control fail (Bell et al 2001). As a consequence

people might think that their behavioural activities have no effect on the situation and stop trying to exercise control.

Constraints can limit or interfere with behaviours persons would like to execute. The belief that there is a constraint could be a constraint itself. Constraints can cause negative affects or discomfort. There are three basic steps in the behaviour constraint model: perceived loss of control, reactance, and learned helplessness (Bell et al, 2001).

Johnson (1974) defined four stages during which people may influence their outcomes (Fig. 3):

- Outcome selection control: is the process of selecting a desirable outcome among several potential outcomes. The outcome could be to attain a preference condition.
- Behaviour selection control: Among several behavioural strategies the one behaviour has to be selected which will be employed in order to attain the outcome selected.
- Outcome effectance: is to create the desired outcome.
- Outcome realisation control: is how to interpret and evaluate the outcomes received. Outcomes realised are the subjective effects.

Behaviour selection control may be perceived as quite stressful compared to outcome selection control. The greater the number of behavioural options offered to a person and the more likely it is that the various options lead to the chosen outcome, the more difficult is someone's task of selection. This is because of the absence of distinguishing reasons to decide for a certain behavioural option.

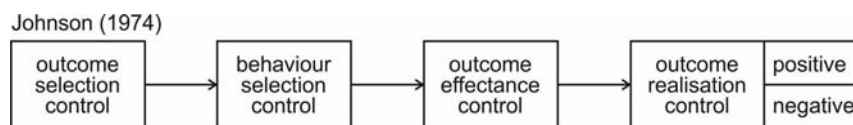

Graphic: Hellwig, 2014

Figure 3. Flow chart explaining personal control using the definition of Johnson (1974).

4 Conceptual models of control and man-environment interaction

Boerstra et al (2012) already looked into available models of control. They divided the models into models describing: physiological processes and actions, psycho-social phenomena, physiological and psycho-social, hybrid models. Küller (1991) posits that interaction between man and environment goes on in four steps: activation, orientation, evaluation and control.

The model of Bell et al (2001) shows the relationship between environment and behaviour (Fig. 4). In the description of the model Bell et al posit that homeostasis is reached either when the environment is to be regarded as within optimal range of stimulation or as to be congruent with the intended behaviour. In the more specific models of Bell et al applied to noise and weather perception the term 'pleasure' was added to the box containing homeostasis. In this model we find control as to be part of the coping strategy and as part of the two boxes standing for the physical and social environment.

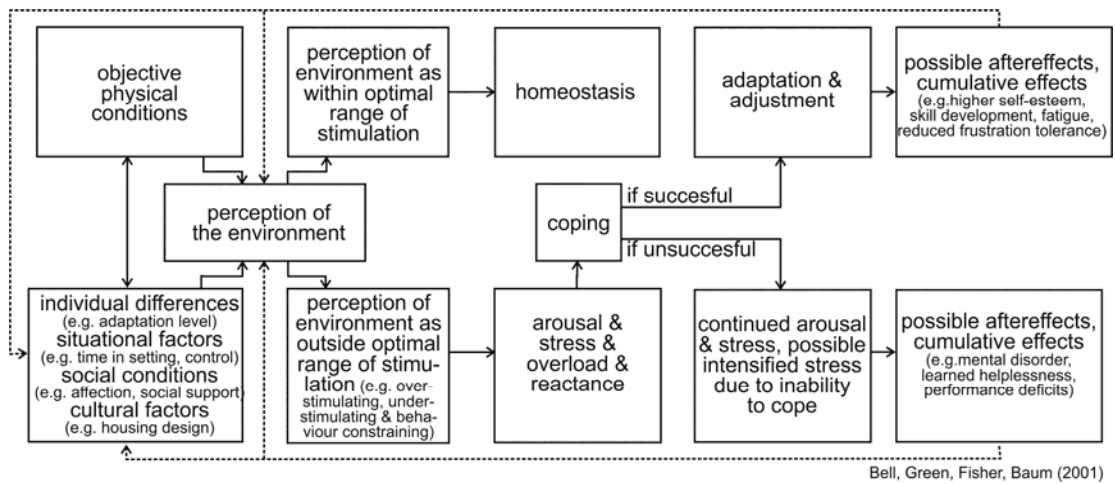

Figure 4. Flowchart of the theoretical concept of environment - behaviour relationship (Bell et al, 2001).

Veitch & Arkkelin (1995) developed a model explaining how the environment indirectly influences behaviour through the role of moderators and mediators (Fig. 5). Moderators increase or decrease the impact of the setting in contrast to mediators which are internal perceptual, cognitive and affective processes in response to environmental conditions. The degree of control felt is seen as an affective process as a result of the social situation and the success or fail in exercising behaviour. The emotional state can influence the expectations and goals of persons. The availability of control means provided by the environment is not shown.

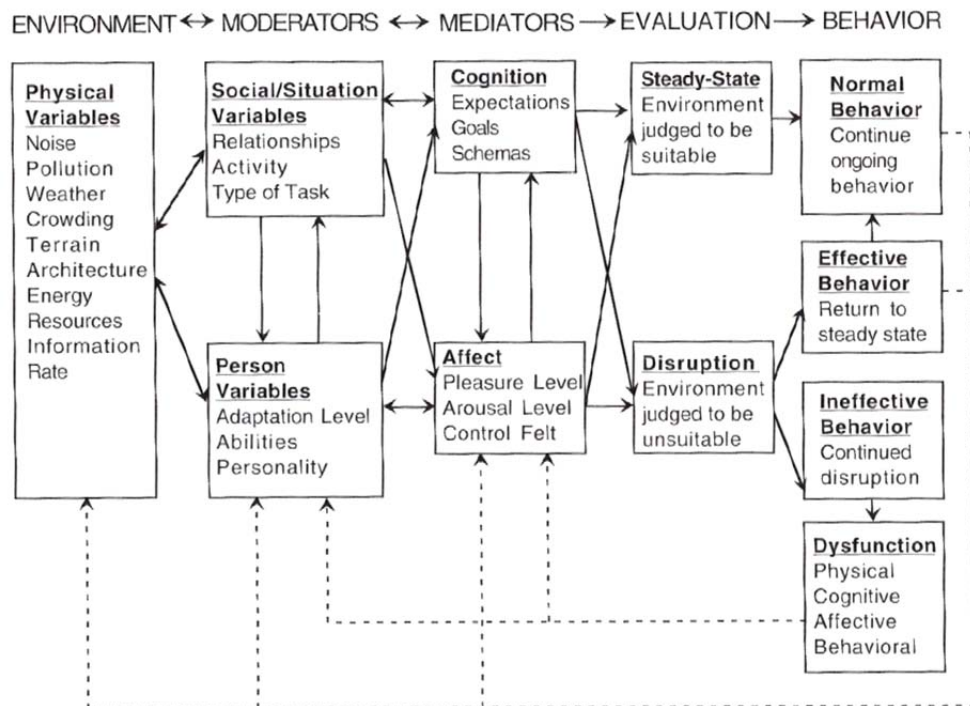

Figure 5. A model of environment – behaviour relationships (Veitch & Arkkelin, 1995)

5 What is perceived control?

In the ProKlimA study 85% of office workers out of 4394 wished to have control over their indoor environment (Hellwig, 2005). Correlations between perceived control and comfort or overall satisfaction could be shown in a number of studies (Kim & de Dear, 2012; Boerstra et al, 2013; Leaman & Bordass, 1999; for overview see Ackerly et al, 2012). Information about perceived control in these studies was gained by asking the occupants: “Do you feel you have control over...” or “How much control do you have over...” (Ackerly et al, 2012).

Paciuk (1990) defined three levels of control (Fig. 6): available, exercised, and perceived control. Available control thereby means not only the control means provided by the building or HVAC system but also organisational norms such as dress code or the degree of manipulation of control means given to the occupants. Paciuk defined perceived control as to be related to both available and exercised control. The knowledge about available controls and the feedback about the effectiveness of exercised control form different levels of perceived control.

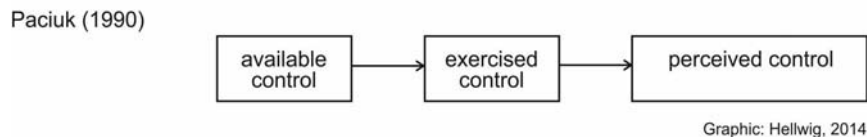

Figure 6. The distinction of control levels according to Paciuk (1990).

Bordass & Leaman (1997) distinguish three components of perceived control: 1. actual control including the zoning of the building, the environmental services, and the use of the area, 2. fine-tuning capability, 3. speed of respond to demands.

Ackerly et al (2012) discussed how to define the availability of controls and how to classify available controls: physical – behavioural; passive – powered controls; direct – indirect or just organise the controls according to the environmental parameter the control is assumed to effect.

Comparing the more general approach of Johnson (1974) with the distinction Paciuk (1990) made parallelism could be seen (Fig. 3 and 6). Available controls represent several behavioural strategies among which one has to be employed (behaviour selection control). Obviously, outcome effectance control and exercised control refer to the same stage. A positive evaluation of outcome (outcome realisation control) may result in a high degree of perceived control because the person succeeded in control. How the outcome realised will be evaluated by a person depends on personal, social and cultural factors. Thus, perceived control may be different in several contexts.

Johnson (1974) distinguishes between primary and secondary control. Primary control behaviour causes outcomes directly. Secondary control is caused by behaviours which increase the likelihood that a primary controlling behaviour will be successful. Secondary control is regarded to be “always at least one step removed from outcome attainment” and thus, secondary behaviour has the potential to be stressful. Hence, the degree of control perceived with primary control will be higher than with secondary control.

Fig. 7, depicted from Baker & Standeven (1997) shows how the availability of adaptive opportunities can expand the individual’s neutral zone. In the case of poor or zero adaptive opportunities a room which does not meet the needs of an individual will lead to stress in the individual. Baker & Standeven posit the importance of the

perceived adaptive opportunity even if the opportunity is not exercised. Nicol & McCartney (1999) found that just adding the number of controls does not give a good measure for the adaptive opportunities in a building.

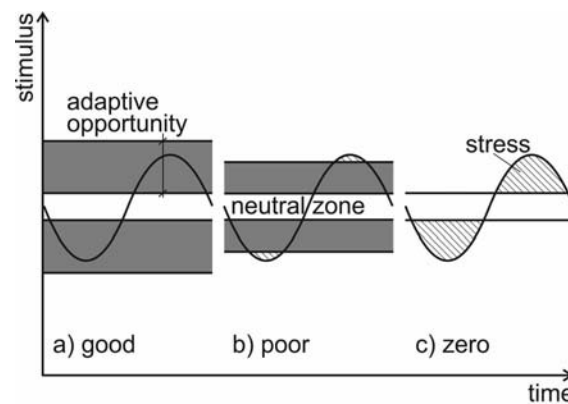

Baker & Standeven (1997)

Figure 7. Comfort range, individual neutral zone, availability of adaptive opportunities and stress. From Baker & Standeven (1997).

It has often been argued that the indoor environment of a building has to be provided according to the occupant's needs. But what this argument means is that a building should provide exactly the environment a person needs. This argument overlooks the context dependency and the individuality character of a person's needs which are the most important issues and have been pointed out in environmental psychology literature (e.g. Bell et al 2001; Veitch & Arkkelin 1995) as well as in literature on physiology and behaviour (see section 3 e.g. Cabanac, 1996) or thermal comfort literature (e.g. Nicol & Humphreys 2002, de Dear et al 1998). Thus, the character of the needs can vary. How could the HVAC system of a building know about the exact need of a certain occupant sitting somewhere in the building on day 1 which may be different from his need on day 2?

Having control over onset and termination of a stimulus will result in better adaptation than having control over only either onset or termination of a stimulus (Bell et al 2001, p115). Lee & Brand (2010) found that personal control over the physical environment mediated the relationship between perceived distractions and perceived job performance. Boerstra et al (2013) suggested looking at control (available, exercised and perceived) as a moderator of the relationship between indoor climate (stimulus) and comfort, health and performance (response).

Based on the work of Humphreys and Nicol constraints in the building context were summarised by de Dear et al (1997) as constraints due to climate, economics, social custom or regulations, task or occupation and design.

From the implementation phase of passive house in Germany it is known that many people have expressed reservations about moving into such a house. The reservations are founded in the indoor environment as to be perceived as artificial and providing no control, and the restrictions which planners as well as researchers put onto the occupants not to open the windows. Later this restriction was identified not to make the passive house concept attractive for people and research effort was undertaken showing that opening the window will not considerably change the energy consumption of the house.

Sherrod & Cohen (1979) point out that perceived control may result as a consequence of actual control but could also be gained from prior control experiences, from information, and from self-inferences.

All building users have experiences with buildings, positive or negative. From these experiences they develop expectations on how an environment should be or will be. In dependence on their own experiences with buildings they rate the subjective importance of environmental factors. When attending a concert a person does not expect of having control over the indoor climate in such a crowded space. Perhaps he or she remembers the last concert in the same place was very hot and adapts his or her clothing according to these expectations. But when it turns out that the concert hall is cool this time the person may be displeased. When moving a company from old uncomfortable offices in the city centre with lots of cafes, restaurant and shops to a suburban, empty area it is likely that the satisfaction of the office workers will not increase even with a very new building, well-designed offices and a comfortable environment.

Constraints and expectations may play an important role in study design investigating comfort or performance and for the results gained from those studies. In a study on office performance in summer conditions Hellwig et al (2012) explained to their subjects the context of their study: working in an office in summer outside temperatures. This idea was supported by a realistic office environment providing view to the outside, sun shading and openable windows. Although none of the subject opened the window, it was not forbidden to them. The subjects were allowed for clothing adaptation during the experiments. The research group decided to not put constraints onto the subjects to keep the setting as close to a normal office environment as possible. Schweiker et al (2012) suggested a controlled test design where constraints are put onto subjects in some of the tests to restrict adaptive opportunities.

Boerstra et al (2013) failed to show a correlation between available controls and perceived control except for the case of solar shading with external shading provided higher perceived control over temperature than internal shading. Hellwig et al (2006) found combined perceived control over temperature and air movement to be significantly higher in naturally ventilated buildings (with central heating in winter) and mechanically ventilated or air-conditioned buildings.

Boerstra & Beuker (2011) distinguished between personal control which is not possible, possible but ineffective, and possible. They called this perceived effectiveness of control. Effective personal control options in offices lead to a decreased amount of complaints compared to those cases with none or ineffective personal control. In a few cases they even determined an increased chance for complaints for the group perceiving ineffective control compared to the group with no control.

In naturally ventilated spaces occupants regarded thermal discomfort as a result of their own behaviour rather than attribute discomfort to the building as in air-conditioned spaces (Kim & de Dear, 2012). The forgiveness factor (Leaman & Bordass, 2007; Deuble & de Dear, 2012) characterises the discrepancy between overall mean comfort and the mean score of a single IE variable and was shown to be higher for green buildings.

Although many studies already investigated available control and perceived control the link between the building design, building services and how occupants perceive control in these environments was not focussed on so far.

“Bicycles can exist without riders and riders without bicycles, but it is the interaction of the two that provides the unique system, or process, of bicycle riding.” (Veitch & Arkkelin, 1995, p 39).

A certain design of a building's floor plan or façade will as a consequence cause certain building services systems for room conditioning. Very big office units i.e. open-plan offices cannot provide access to windows for every occupant, even the implementation of natural ventilation during occupancy is very unlikely. Because of the huge depth of such buildings heating will be provided via the ventilation system which at the same time induces that there will be less control in the space (personal ventilation is not widely used in real buildings, yet). Buildings with a very high proportion of glazed area in the façade have a potential to reduce perceived control because the occupants have to solve for conflicting goals: either having a view to the outside or let the sun heat up the space. The building's construction influences perceived control also: The effectiveness of temperature control devices is influenced by the thermal inertia of a building and its combination with a heating or cooling system.

Hellwig et al (2006) investigated perceived control in dependence of the heating and ventilation system in buildings with mechanical ventilation from the ProKlimA-study. The mean value of perceived control (combined control on temperature and air movement; scale 0-1) is 0.23 in buildings with an air heating system and 0.51 in buildings with radiators. Buildings with sealed windows have a mean value of perceived control of 0.19. The value increases up to 0.48 in mechanically ventilated buildings with openable windows.

To report from real building experience: A building with e.g. a thermo-active building system (TABS) for heating and cooling will react very slowly. It is called a passive technology but when heated once it cannot be used for cooling in the same day because of its thermal inertia. Normally there should be a dead band between heating and cooling in the operation mode of such a system. Combining, e.g. a slowly reacting activated building element with a high percentage of glazed area in the façade will result in a coincidence of heating from the ceiling and heating through a high amount of passive solar gains and lead to high temperatures even in winter at outside temperature levels far below zero. If there is a thermostat mounted and the user will try to lower the temperature in the room he will not succeed because of the high inertia of the system. A completely different picture gives a room with high thermal mass, which is not activated. In this room the heat resulting from solar gains could partly be stored in the thermal mass and the temperature will rise more slowly than in the first case. If this room was combined with radiators the occupant could adjust the thermostat or just rely on the proper functioning of the thermostat.

Finally, with regard to building automation, excellent studies were carried out and guidance was provided on how to improve the design for high usability of user interfaces of building automation (Stevenson et al 2013; Bordass et al, 2007).

6 A conceptual approach explaining perceived control as a key factor for satisfaction

The equilibrium of an environmental factor in a person differs with time, internal state, activity, and expectations. So the desirable steady state can be different. An environment which is suitable e.g. on one day or for one activity or one person could be not on or for another. Thus, an environmental stimulus can be perceived as disruptive for one person but could be perceived as to be perfect for another person. Effective behaviour as the consequence of a disruption caused by the environment could be perceived as pleasurable and hence, will cause satisfaction as long as the selected effective behaviour is consistent with the expectations (of an appropriate behaviour). The disruption can be compensated by effective behaviour and therefore cause positive feelings already before the steady state is reached again. This seems to be a strong motivator to exercise effective behaviour.

Analogy between general models of control like locus of control or self-efficacy and perceived control could be drawn. Even if the concepts of locus of control or self-efficacy are more generalised ones and perceived control in a built environmental context is more specific their impact on a person's attitudes and expectations seems to be quite similar. Kim & de Dear (2012) already draw this analogy to distinguish NV and AC buildings.

Boerstra et al (2012a) listed key attributes for feedback looped psycho-physiological models:

- “Distinction between information, heat flow and action
- Separation of physiological effects and autonomic regulation on the one side and psychological effects and behavioural regulation on the other side;
- distinction between perception, interpretation and action plan development
- inclusion of situation, habituation and adaptation effects
- inclusion of memory and expectation effects
- separation of available controls, exercised control and perceived control
- distinction between external, environmental control (e.g. adjusting thermostats, opening windows) and ‘internal’ control (e.g. changing clothing or metabolism)”

What is perceived control?

It is suggested that perceived control can be defined by using the generalised concept of locus of control and the complementary concept of self-efficacy and use them more specific on the level of indoor environment in buildings. Thus locus of indoor environmental control (IE control) is linked to the experiences of a person with indoor environments. A high locus of IE control means a person believes he or she can cause changes in the indoor environment. A high IE self-efficacy means a person is convinced that he or she has the capabilities or skills to cause these changes. To finally define what actual perceived control means the influence of constraints from the degree of responsiveness of the system building – HVAC – automation, the social constraints, the expectations resulting from individual weighting factors for the importance of IE variables, and the feedback (outcome realisation control) have to be considered.

Fig. 8 shows the resulting model merging aspects of the above described models. For the sake of clear arrangement it was impossible to include the huge variety of control actions and the distinction between information, heat flow and action. The model

explains how occupants perceive the built environment and how behaviour by means of control mediates the evaluation of the environment. It does not account for autonomic processes but focusses on behavioural actions. The model aims to explain the different stages of control and to show how perceived control is formed.

Satisfaction is shown to result not only from comfort but as well from pleasure. Constraints coming from the building, particularly the building's responsiveness, and the social environment reduce the variety of available controls occupants can select. Perceived control results from the person's experiences, competences or skills (self-efficacy, locus of control of indoor environment), knowledge of the building and its technical systems and the person's expectations. Together with the constraints and the success or failure in previous behavioural control actions these variables form the term perceived control.

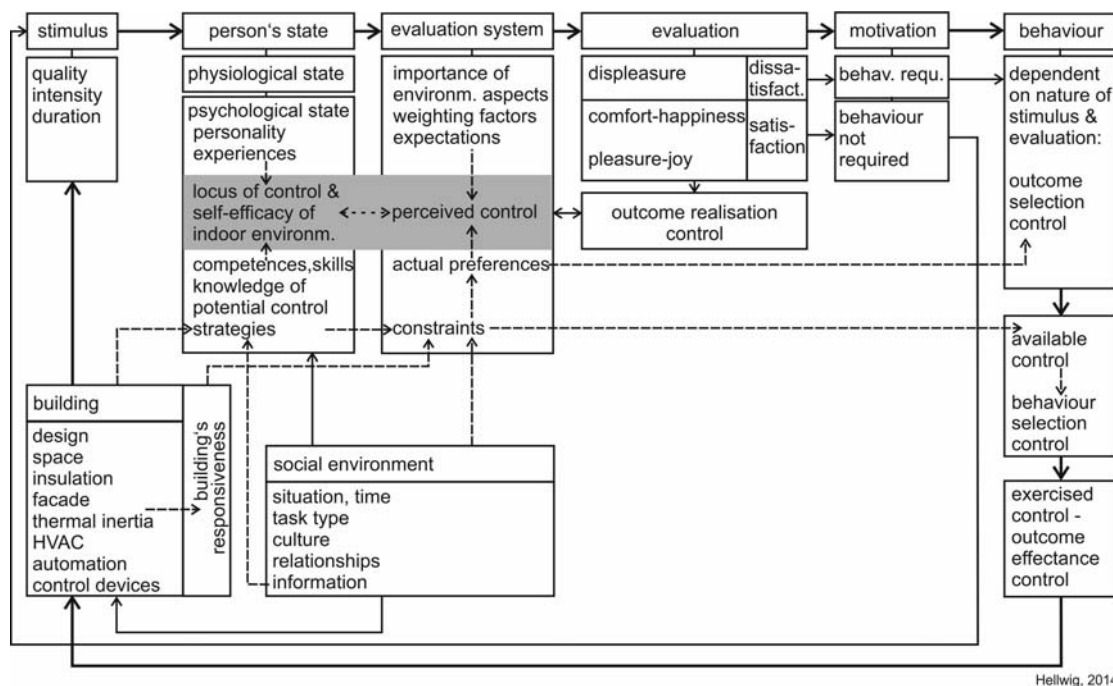

Figure 8. A conceptual approach explaining perceived control as a key factor for satisfaction.

7 Conclusions and outlook

A conceptual model was developed including psychological constructs from social learning theory and personality psychology transferred to the field of personal control of the indoor environment. Furthermore, the idea in behavioural psychology that taking a meaningful action is rewarded by joy seems also applicable to the man-indoor environment interaction. Thus, satisfaction with the indoor environment occurs in case of comfort but also immediately after a successful control action even when homeostasis has not yet reached. There are constraints from the built and social environment determine the available controls. The model should be proved in practice.

Future perceived control studies should put more emphasis onto the investigation of the effectiveness of a control action in the context of the design of the building and its interaction with the HVAC systems. In this context further research is needed to describe the required degree of responsiveness of the system building-HVAC-

automation. Furthermore, advanced knowledge is needed to better understand the impact of user information or guidance which could help to increase the perceived control in buildings.

References

Ackerly, K.; Brager, G.; Arens, E. (2012): *Data Collection Methods for Assessing Adaptive Comfort in Mixed-Mode Buildings and Personal Comfort Systems*. Indoor Environmental Quality (IEQ), UC Berkeley: Centre for the Built Environment, Centre for Environmental Design Research.

ASHRAE Standard 55 (2010): *Thermal Environmental Conditions for Human Occupancy*.

Baker, N.; Standeven, M. (1997): *A behavioural approach to thermal comfort assessment*. Int. J. of Solar Energy, Vol. 19, 21-35.

Bandura, A. (1994): *Self-efficacy*. In: Ramachandran, V.S. (Ed.): *Encyclopaedia of human behavior*. Vol.4, 71-81. New York: Academic Press.

Bell, P.A.; Green, T.C.; Fisher, J.D.; Baum, A. (2001): *Environmental psychology*. 5. ed. Belmont, CA: Wadsworth.

Boerstra, A.C.; Beuker, T.C. (2011): *Impact of perceived personal control over indoor climate on health and comfort in Dutch offices*. 12th International Conference on Indoor Air Quality and Climate. Austin, Texas, Vol.3, 2402 – 2407.

Boerstra, A.C.; Beuker, T.; Loomans, M.; Hensen, J. (2013): *Impact on available and perceived control on comfort and health in European offices*. Architectural Science Review, Vol. 56, 1, 30 - 41

Boerstra, A.; Loomans, M.; Hensen, J. (2012): *Modelling control over indoor climate*. International Society of Indoor Air Quality and Climate -ISIAQ- Healthy Buildings Conference, Brisbane 8.-12. July, 2012, paper 6.E.2, 6 pp.

Bordass, W.; Leaman, A. (1997): *Future buildings and their services. Strategic considerations for designers and clients*. Buildings Research and Information, 25, 4, 190-195.

Bordass, W.; Leaman, A.; Bunn, R. (2007): *Controls for end users: A guide for good design and implementation*. Reading, UK: Building Controls industry Association.

Cabanac, M. (1996): *Pleasure and joy, and their role in human life*. Institute of Public Health, Tokyo, Proceedings Indoor Air, 1996, 3, 3-13

de Dear, R. (2011): *Revisiting an old hypothesis of human thermal perception: allesthesia*. Building Research and Information, 39, 2, 108-117.

de Dear, R.; Brager, G. (1998): *Thermal adaptation in the built environment: a literature review*. Energy and Buildings, 27, 83-96.

de Dear, R.; Brager, G., Copper, D. (1997): *Developing an adaptive model of thermal comfort and preference. Final report*. ASHRAE Report 884.

Deuble, M.; de Dear, R. (2012): *Green occupants for green buildings: The missing link?* Building and Environment, 56, 21-27.

EN 15251 (2007): *Indoor environmental input parameters for design and assessment of energy performance of buildings addressing indoor air quality, thermal environment, lighting and acoustics*. German version, August 2007.

Hellwig, R.T. (2005): *Thermische Behaglichkeit - Unterschiede zwischen frei und mechanisch belüfteten Gebäuden aus Nutzersicht (Thermal Comfort - Natural Ventilation versus Air-Conditioning in Office Buildings from the Occupant's Point of View)*. Doctoral Thesis, Munich: University of Technology Munich, November 2005.

Hellwig, R.T.; Brasche, S.; Bischof, W. (2006): *Thermal Comfort in Offices – Natural Ventilation vs. Air Conditioning*. In: Proceedings Windsor Conference: Comfort and energy use in buildings –getting them right. Cumberland Lodge, Windsor, UK, 27.-30. April 2006. London: Network for Comfort and Energy Use in Buildings.

Hellwig, R.T.; Nöske, I.; Brasche, S.; Gebhardt HJ.; Levchuk, I.; Bux, K.; Bischof, W. (2012): *Subjective and Objective Assessment of Office Performance and Heat Strain at Elevated Temperatures - The HESO-Study*. International Society of Indoor Air Quality and Climate -ISIAQ- Healthy Buildings Conference, Brisbane 8.-12. July, 2012, paper 7C.7, 6 pp.

ISO 7730 (2006): *Ergonomics of the thermal environment - Analytical determination and interpretation of thermal comfort using calculation of the PMV and PPD indices and local thermal comfort criteria (ISO 7730:2005)*; German version , May, 2006.

ISO 9241-11 (1998): *Ergonomics of human system interaction: guidance on usability*.

ISSO 74 (2004): *Thermische Behaaglijkheid. Eisen voor de binnentemperatuur in gebouwen*. Rotterdam, 2004.

Johnson, C.A. (1974): *Privacy as personal control*. In Carson, D.H. (Ed.): *Man-environment interactions: Selected papers presented at EDRA 5*, Washington DC: Environmental Design Research Association. Vol. 6, 83-100

Kim, J.; de Dear, R. (2012): *Impact of different building ventilation modes on occupant expectations of the main IEQ factors*. *Building and Environment* 57, 184-192.

Küller, R. (1991): *Environmental assessment from a neurophysiological perspective*. In: Gärling, T.; Evans, G.W. (Eds.) (1991): *Environment, cognition and action – an integrated approach*. New York, Oxford, Oxford University Press.

Leaman, A.; Bordass, B. (1999): *Productivity in buildings: the ‘killer variables’*. *Building Research and Information*, 27, 1, 4-19.

Leaman, A.; Bordass, B. (2007): *Are users more tolerant of green buildings?* *Building Research and Information*, 35, 6, 662-673.

Lee, S.Y.; Brand, J.L. (2010): *Can personal control over the physical environment ease distractions in office workplaces?* *Ergonomics*, Vol 3, 3, 324-335.

Nicol, J.F.; Humphreys, M.A. (2002): *Adaptive thermal comfort and sustainable thermal standards for buildings*. *Energy and Buildings*, Volume 34, Number 6, July 2002 , pp. 563-572(10).

Nicol, J.F.; McCartney, K.J. (1999): *Assessing the adaptive opportunities in buildings*. In: *Proceedings of the CIBSE National Conference*, London: Chartered Institute of Building Service Engineers, 219-229.

Paciuk, M. (1990): *The role of personal control of the environment in thermal comfort and satisfaction at the workplace*. In: Selby, R.I., Anthony, K.H.; Choi, J.; Orland, B. (Eds.) *Coming of Age. Environmental Design Research Association*. Oklahoma. EDRA21, 303-312.

Rotter, J.B. (1982): *The development and application of social learning theory*. New York: Praeger.

Schweiker, M.; Brasche, S.; Bischof, W.; Hawighorst, M.; Voss, K.; Wagner, A. (2012): *Development and validation of a methodology to challenge the adaptive comfort model*. *Building and Environment*, 49, 336-347.

Sherrod, D.R.; Cohen, S. (1979): *Density, Personal Control, and Design*. In: Aiello, J.; Baum, A. (Eds.): *Residential Crowding and Design*. Springer US, 217-227

Stevenson, F.; Carmona-Andreu, I.; Hancock, M. (2013): *The usability of control interfaces in low-carbon housing*. *Architectural Science Review*, 56, 1, 70-82.

Veitch, R.; Arkkelin, D. (1995): *Environmental psychology – an interdisciplinary perspective*. Englewood Cliffs, NJ, USA: Prentice Hall.

UBT Usable Buildings Trust (several years): www.usablebuildings.co.uk, UK

Proceedings of 8th Windsor Conference: *Counting the Cost of Comfort in a changing world* Cumberland Lodge, Windsor, UK, 10-13 April 2014. London: Network for Comfort and Energy Use in Buildings, <http://nceub.org.uk>

Applying contextual understanding in mixed mode design: a user-centred study of thermal comfort and adaptive control

Kathryn Healey¹

1 School of Architecture, University of Queensland, Australia, k.healey1@uq.edu.au

Abstract

In achieving low-energy operation, occupant-controlled mixed mode buildings rely as much on the judicious use of active climate control by occupants as they do on the efficiency of the building services. The extent to which occupants choose to use natural ventilation for creating a thermally comfortable environment is informed in part by the human heat balance, and by the availability and effectiveness of adaptive comfort devices, but is also a function of social, cultural, and local context. Qualitative study is suited to exploring these factors in more detail. The paper presents a case study using qualitative interviews, focusing on an occupant-controlled mixed-mode office building in the warm humid climate zone of Australia. Occupant attitudes which tend to entrench the use of natural ventilation or, conversely, active climate control, are identified, and these are used to create guidelines for encouraging the judicious use of energy by occupants.

Keywords: Mixed mode, adaptive thermal comfort, qualitative research

1 Introduction

In pursuing low energy operation, occupant-controlled mixed mode buildings should aim to minimise the proportion of time the occupants choose to rely on active climate control. Such buildings rely on the efficient use of energy by the building services and the judicious use of energy by the building occupants. The building design should provide, in order of priority, climatically appropriate passive design strategies which take advantage of and temper external conditions, personal adaptive devices reflecting the comfort preferences and functional needs of the occupants, and finally, active temperature control systems which can be used when climatic extremes exceed the limits of passive and personal adaptive responses.

A great uncertainty in mixed mode design is in anticipating how occupants will use adaptive comfort devices, and under what circumstances they will choose to use active systems. These questions can be answered in part using predictive (quantitative) comfort models. However, comfort models are by necessity context-free and do not provide guidance of, for example, to what extent the occupants value energy conservation, or how they judge the quality of a naturally ventilated environment. As a result, the greater the low energy design strategy relies on occupant control, the more difficult it is to predict the building's eventual energy use. This uncertainty can make occupant-controlled buildings a less attractive prospect, despite their potential to achieve significant energy savings, and can compel designers to err on the side of a more predictable design strategy. Analogous problems with the way we assess the performance of naturally ventilated buildings has been previously raised by others (e.g. Roaf et al, 2010).

The adaptive comfort model is valid for fully naturally ventilated buildings, and can for mixed mode provide guidance of the thermal conditions under which occupants will become uncomfortable and choose to use active systems. Quantitative studies of occupant control (e.g. Baker and Standeven (1994), Brager et al. (2004), Haldi and Robinson (2010)) can be used to inform energy modelling algorithms. Qualitative understanding of the occupants, their social and cultural setting, and climatic and local context can complement these approaches by considering behaviours that occur outside of the deterministic relationship between the thermal environment and occupant comfort. Applying this insight can improve low-energy building design whilst considering in more detail the needs of occupants, and should help produce buildings which are comfortable, low energy, and judged positively by occupants over the long term.

Qualitative study can improve understanding by exploring the acceptability of adaptive practices and experiential dimensions in favour of temperature-based comfort limits (Hitchings, 2009). Such an approach aims for thermal delight, rather than neutralisation, by enhancing sensory experience and valuing the quality of indoor environments (Heschong, 1979). Chappells and Shove (2005) identify these two contrasting considerations of comfort; comfort as universally definable state as per the quantitative, deterministic model, and comfort as a socio-cultural achievement, or the qualitative, constructivist model.

A user-centric approach (Vischer, 2008) recognises both the value and limitation in environmentally deterministic study of built spaces, and likewise in the constructivist approach which considers sociocultural context. Applying Vischer's user-centred theory combining both worldviews is suited to the mixing of quantitative and qualitative research paradigms, asking dual questions:

- What is the effect of the indoor environment and building systems on comfort?
- How do people feel about and respond to the built environment?

It is the second question which is the focus of this paper, in the context of an occupant-controlled, mixed-mode study building. The first question was examined for the same building in a previous work (Healey, 2014) and key results are outlined below. A post-occupancy evaluation has also been carried out by others (Best and Purdey, 2012).

This paper argues that the social, cultural and climatic context of the building and its occupants can tend to entrench a culture of comfort achieved primarily via natural ventilation and the judicious use of energy for climate control, or can entrench a culture which defaults to the unrestrained use of energy for the achievement of comfort. The paper identifies key themes in achieving and mediating the balance between the building and its occupants to create an environment which is comfortable and of low energy consumption.

1.1 Study building

The study focuses on administrative and academic staff occupying mostly one- and two-person offices over two levels of a three-storey building at Bond University on the warm humid Gold Coast in Queensland, Australia. The climate is comfortable for much of the year, excepting cool winter mornings and hot, humid days in summer. The building has a high profile as an example of a sustainable development and has received multiple awards for its environmental design. Many of the occupants play a role in promotion of the building through facilitation of building tours.

The building has changeover mixed mode air conditioning systems used for climate control, interlocked with openable windows and internal doors, with each office having an independently user-operated system. The only constraint to the use of the air conditioning system was a building-wide natural ventilation mode which is enforced when external conditions are between 19 and 25°C. Each office is controlled by a hotel-style key switch, or ‘office ignition’, which must be turned on by the occupant in order for the lighting, HVAC, and ceiling fan to be used.

Previous work demonstrated a general preference for natural ventilation among occupants (Healey, 2014). The use of air conditioning was limited by a number of non-thermal factors:

- The need to maintain a sociable working environment and to present a welcoming impression to visitors meant that internal doors were normally left open, precluding the use of the air conditioners;
- The inconvenience of having to stand up to turn on the air conditioning system via a wall-mounted panel;
- Intermittent office occupancy combined with the hotel-style key switch reduced the amenity of the air conditioner, as it forced shut-down when vacating and there were subsequent start-up delays when the room was reoccupied;
- A desire among occupants to use energy frugally and to be seen to be doing so;
- A preference for natural ventilation, including a perception that natural ventilation was healthier than air conditioning; and
- A demonstrated tendency to tolerate considerable discomfort before making an adaptive action to restore thermal comfort.

All occupants reported using the heating for up to one month of the year, if at all, and around three quarters reported using cooling for up to one month, with the remainder using cooling more often (Healey, 2014). This is significantly less than was predicted in design, when it was estimated natural ventilation would be used for two months of the year (Healey et al, 2007). Reliable energy consumption data was not available.

2 Methods

The study involved one-on-one, semi-structured qualitative interviews with 28 occupants, generally of around 20 minutes duration per occupant. Interviews are useful for learning how individuals feel about, perceive and react to their environment (Zeisel, 2006). Semi-structured interviews follow a checklist of topics with default wording and order for the questions, but can be modified based on the flow of the interview and supplemented with unplanned follow-up questions (Robson, 2011). This structure allows flexibility and depth in responses, and was adopted in this study in order to explore occupant experience in the occupants’ own words. The interviews avoided jargon typical of conventional thermal comfort questionnaires, and covered the following general topics:

- General opinion of the building including likes, dislikes, knowledge and confidence in its operation, and the impression the building gives to visitors;
- Opinion on the environmental sustainability of the building, and whether this is important to the occupant;
- Experience of thermal comfort and discomfort, use of adaptive comfort devices, and approach to adaptive comfort at home;
- Experience of noise, lighting, and other non-thermal indoor environment quality issues;

- Dress code and clothing adaptation;
- Open-ended questions providing the opportunity for further comments; and
- Any impressions of interviewer bias.

Thematic coding was used to sort and analyse the data, using NVivo software. This process involves tagging passages of transcribed interviews according to the topic of discussion, allowing themes to emerge rather than being imposed. The themes were then examined to identify issues of importance to occupants and common experiences or perceptions, and these were then considered in terms of their interaction with the cultural setting, and whether they tended to entrench the judicious, or unrestrained, use of energy. These results were used to develop understanding of how the social setting, the environment, and the local context mediate the balance between occupant comfort and energy consumption.

Interviews, particularly those with looser structures, can be problematic in their relationship to theory, in data reliability, and in analysis. In using these methods, research techniques must display awareness of potential issues and respond appropriately. Potential issues include:

- **Standardisation and reliability:** the validity of comparing data from different occupants can be questioned where a standard process was not followed. In this case, each interview was different due to the adoption of a loose structure, allowing different questions to be asked. For each interview, a common ‘map’ was followed, and each was conducted within a single block of time and by the same interviewer.
- **Interviewer bias:** perceived bias of the interviewer can cause interviewees to colour their responses. In this case, the emphasis on the sustainable design aspects of the building may have caused occupants to ‘talk up’ their environmental awareness. One method of identifying bias (Robson, 2011) is to ask interviewees directly of their perceptions of bias at the conclusion of the interview. 25 occupants responded to this question; of these, none raised any concerns regarding bias or leading questions.
- **Trustworthiness:** trustworthiness in flexible research designs such as semi-structured interviews can be difficult to establish, due to the lack of explicit controls, measurements, or repeatability (Robson, 2011). Procedures adopted for demonstrating credibility included audio taping to ensure a valid descriptive record, inclusion of contradictory results in the analysis, mixing of methods to include standardised research designs, as has been previously published (Healey, 2014), and triangulation with other relevant existing research (see Best and Purdey, 2012).

3 Results

This section details the themes and provides examples of occupant responses, and a short summary of the responses is provided at the end of each section. Where occupants were asked about a particular aspect directly, a greater number of responses were received. Other results were not gained via direction questions and instead were volunteered by the occupant; unsurprisingly, these emergent responses tended to be lower in number.

Four key themes emerged from the interviews; the perceived health risks of air conditioning, the impact of the social setting, the impact of the physical setting, and the level of knowledge on the part of the occupants.

3.1 Perceived health risks of air conditioning

A widely held perception was that air conditioning was unhealthy due to air recirculation, low humidity, and dirty filter media (Table 1). This perception was not specific to the building but was a generally held personal view of air conditioning, and is an example of a ‘folk theory’ (Strengers and Maller, 2011) through which people express their preference or dislike and form their understanding of how air conditioning should be used. The corresponding perception in which natural ventilation has a positive influence on health was also held. There were two exceptions where occupant of cooling-reliant thermal disposition (Healey and Webster-Mannison, 2012) felt distress or excessive discomfort when prevented from using active cooling.

The perceived role that air conditioning systems play in the transmission of illness within a workplace was seen as important. The study building was judged as healthy due to the option of not using air conditioning, the absence of a return air path, and the small occupancy of most offices.

... if you sit in an air conditioned environment you just catch everything.

I’m not a big fan of the way it circulates and you can get sick if someone else is sick. I’ve heard a lot of that happening. But I don’t know exactly how it all works and if that is true.

The quality of air provided by the air conditioning system, especially the dryness and cleanliness of the air, was seen to contribute to ill health. Likewise, open windows and access to breezes were seen as very positive qualities.

I just feel like I’m dried out. I don’t think it’s good for your body.

It’s dry air, it’s mechanically treated, so it’s artificial air for me. It has to run through a filter whereas we could have fresh air from outside.

Air conditioning influences physical comfort, in terms of thermal and respiratory comfort, but also psychological comfort, in the occupants’ interpretation of health impacts. This perception reinforces itself as it continues to be experienced and shared between occupants, and hence tends to support the use of natural ventilation in preference to air conditioning and entrenches a culture of energy judiciousness. As a folk theory, it is independent of the building and the organisation, but instead exists within the broader cultural setting.

The result is that many occupants chose to operate the air conditioning for limited periods of time as a kind of corrective action, defaulting back to natural ventilation when conditions were suitable.

Table 1. Summarised responses - perceived health risks.

Topic	Direct question?	Supporting responses	Contradictory responses	Notes and clarifications
Unhealthiness of AC	No: occupants were asked their general opinion of AC	11	2	Many felt AC remained a necessity for comfort in this climate.

3.2 Impact of the social setting

The occupants were asked to share their views on the social setting (Table 2). Social conditions within the building had created an expectation that occupants use, and are seen to be using, energy and other resources conservatively. This has come about partly through planned organisational measures, and also spontaneously.

Deuble and de Dear (2012) found that ‘green’ occupants with pro-environmental beliefs were more forgiving of suboptimal indoor conditions than their non-green counterparts, and that this was more so the case for occupants of green buildings. The study building accommodates staff from a school of sustainable development, indicating a high level of environmental awareness, and most stated that they valued working in a sustainably-designed building. Additionally, some felt it important that they were seen by students as fulfilling their responsibility to demonstrate a pro-environmental attitude.

So yes, it is important for me to believe it is sustainable for me to teach them ... because if I don't believe it they pick up on it, they notice, she's just saying something she doesn't believe.

Interestingly, several occupants felt the experience of working in the building had cultivated their own interest in sustainability and that they had subsequently changed their habits both at work and at home.

Is it really going to save the world, putting a can in that bin other than that bin? But since I've started here I've changed that mindset. So it's pushed me in that direction and I'm finding it more and more important.

I used to use the dryer a lot and leave things on, but I've bought a clothes airer and a clothes line and I use that now. I turn the TV off at the TV and not just with the remote now. I am changing the way I think. I use less water.

The manager had played a role in influencing organisational culture; one example being their response to initial comfort complaints by placing responsibility for achieving thermal comfort with the occupants, rather than with the building.

When the staff first moved into this building ... It was an unusually wet and cold day, and I got some unusually aggressive emails from some of my staff saying, "this is a horrible building, it's cold," and so I just said, "put a jumper on". And that's the philosophy, you dress for it.

Peer expectations motivated occupants to conserve energy, and not be seen wasting energy. This had created feelings of guilt among those with a greater reliance on cooling; likewise, occupants portraying energy-saving behaviour felt virtuous. Occupants framed their energy use in terms of a perceived personal ‘quota’ and used this reasoning to justify it. There was no tangible feedback provided to occupants on actual energy consumption – neither on a whole building nor an individual level – and hence all of these effects were based in perception.

I am somewhat self-conscious of the fact that I have a need for air conditioning.

[There is only] that month in summer and month in winter when I do use the air conditioning. And I still feel fairly virtuous because I know the rest of the year I don't need it.

...considering there's two people sharing [the office] I think that's a bit better – splitting the air conditioning.

Some social constructions favoured the use of climate control. Consideration of the comfort needs of visitors is a strong motivator linked to notions of cooling as a socially hospitable practice (Strengers and Maller, 2011), and climate control as a symbol of corporate prestige (Chappells and Shove, 2005). There can be a tendency to assume that others prefer air conditioning and consider it 'normal', and that natural ventilation is a second-rate option.

I probably should turn it off ... but I think that if I come back and I have a student waiting, this office is so hot ..., how do they feel? I'm thinking of them as well.

Finally, occupants interpretation of the appropriate mode of dress had an impact in some cases. Most felt that they could dress to the conditions, with the summer conditions being more limiting, but some constrained their ability to dress for comfort based on a need to appear professional and to avoid 'looking like a student'.

Table 2. Summarised responses - social setting.

Topic	Direct question?	Supporting responses	Contradictory responses	Notes and clarifications
Values a sustainable workplace	Yes; "Is it important to you that you work in a sustainable building?"	20	6	Contradictory responses included those ambivalent or neutral.
Has changed own habits to be more pro-environmental	No: raised after discussing values	3	-	Many other occupants claimed to be already practicing pro-environmental behaviours.
Perceived peer expectations assigning a moral value to energy use	No	6	1	Many other occupants expressed consciousness of energy use. Contradictory response was "do as I say, not as I do".
Concern for comfort needs of others	No	2	-	
Able to dress to the climate most of the time	Yes: "Does the dress code affect your ability to dress to the climate?"	20	7	

3.3 Impact of the physical setting

Environmental determinism in thermal comfort research is normally involved with relating the human heat balance and comfort, or understanding the use and impact of adaptive comfort devices. In addition, aspects of the physical environment influence physical, functional, and psychological comfort through cues, reminders, constraints and processes embedded into the architecture, building services and control systems. The study building's control devices including sensor lighting, manual and automated comfort systems, and the office ignition, had an impact on the way the occupants felt about their building and influenced their behaviour accordingly (Table 3).

Devices and systems which were well-designed had a positive impact by providing reminders of the sustainable qualities of the building and by guiding occupants in its correct operation. Reminders served to maintain awareness of embedded sustainable design features, for example by using motion-sensor lighting in intermittently occupied shared spaces such as bathrooms. Visible reminders can entrench a culture of energy-judicious behaviour by demonstrating that the building is upholding the same responsibility to conserve energy that is requested of the occupants.

The fact that when you walk into a room the lights turn on, and when you go out there's no movement and they turn back off. You notice that and appreciate it.

Controls which guide occupants in the low energy operation of the building impose a small inconvenience barrier without unnecessarily interfering with occupant comfort or functional needs. The office ignition and the window interlocks with the air conditioning were successful in achieving this, although Brager (2009) notes that window interlock systems tend to be disliked in more open plan-style workplaces. Features which guide occupant behaviour additionally provided assurance that other occupants were operating the building correctly, which helped cultivate a culture of shared responsibility.

As annoying as it is to have to put your keys in there, it's actually pretty good because it forces you not to be lazy about leaving stuff on.

The fact that you can open the window, that it acknowledges if you want to put the air conditioning on, that you can't if the window is open ... little programs like that I think are effective. Because not everybody thinks about that, they'll turn on the air conditioning and not think, should I shut my window or shut my door.

In general, successful controls are those which match occupant expectations with their experience of the building and are achieved via a fully developed and executed design concept.

Dysfunctional controls include those which interfere with occupants' functional needs, particularly when this occurs in the presence of others (i.e. students and visitors), and these were identified as an issue in both the post-occupancy evaluation (Best and Purdey, 2012) and the interviews.

The things I don't like are the sensors for the lights, since I'm just here in front of my computer and my work is just sitting here reading and writing, and I don't move much, so if you don't move like in 10 minutes, then the lights don't turn on.

Systems which do not directly affect occupants, but visibly waste energy, create feelings of resentment as occupants see their own energy-conserving behaviour compromised by poor design, as though the building is not upholding its side of the arrangement. This can erode the culture of energy-judiciousness.

I do find it very often annoying that the lights go on without needing to be on and things like that, you just go, come on really do we need this?

Table 3. Summarised responses - physical setting.

Topic	Direct question?	Positive experiences	Negative experiences	Notes and clarifications
Building automatic controls	No: raised while discussing building services generally	8	15	Some occupants reported both positive and negative experiences

3.4 Knowledge of and engagement with the building

A widely-recognised barrier to realising lower energy use in buildings is correct operation by occupants, supported by knowledge, training and engagement. This was especially the case for the study building as it relied on occupant choice between natural ventilation and active climate control. In the interviews, occupants were asked about their knowledge of and confidence in operating the building correctly (Table 4).

A building users' guide (BUG) describing the features and operation of the building was produced and made available to the occupants, although many were not aware of it. In addition, a series of information panels were placed around the building describing environmental design features, such as automation, efficient plant, and recycled materials. Building tours were conducted regularly by some staff.

These intentional measures to train and engage staff in building operation had varying success, and some unplanned impacts. The BUG and information panels present the building as a modern design with complex automation, which may have caused some occupants to underestimate their ability to operate it confidently. However, all understood the functional control of their usual workspace to an adequate degree. There was a deficiency in some occupants' ability to properly operate less familiar spaces, partly due to lack of training and partly due to dysfunctional or confusing controls design.

No. I probably wouldn't know how to... know about all the facts and features down there in that room, I wouldn't know how to operate it, but as far as being able to put the key in the wall and turn on the air conditioner ...

...as far as my office, yes, but when it comes to our staff common room down the end I'm never sure what happens with the air conditioning in that room.

Those occupants who conducted building tours benefited from a more thorough understanding of the building. Aside from this, the tours had unplanned benefits; the presence of the tours served as a reminder to all occupants that their building was of

noteworthy design, which fostered a sense of awareness and pride. This provided motivation to engage in and maintain its proper operation. The ongoing nature of the building tours meant that they were far more effective in retaining knowledge and engaging staff, particularly when compared with the BUG, which has not been well used.

An important aspect of information and engagement is the provision of feedback on the building performance to occupants, in order to demonstrate the outcomes of their efforts. This is especially the case, given the need to maintain a culture of judicious resource use, and the extent that responsibility for resource use is placed with the occupants. While there is a building performance information display, information is not provided directly to the occupants in a meaningful context; as a result, there is little demonstration that occupant efforts in carrying out pro-environmental behaviours are having the intended effect.

Table 4. Summarised responses - knowledge and engagement.

Topic	Direct question?	Yes, with reservations	Yes	Notes and clarifications
Understands how to operate the building	Yes: "Do you feel you understand how to operate the building properly?"	14	12	Own perception and hence related to confidence.

4 Discussion

4.1 Occupant attitudes

The results are summarised here, re-worded to illustrate the occupants' attitudes in simple terms and grouped according to their theme (Table 5). In the context of the research question, these attitudes have one of two outcomes; they can tend to entrench a culture which values the judicious use of energy, and default to natural ventilation, or can tend to entrench a culture where energy use is not restrained and active climate control is the default, and are categorised along these lines.

Table 5. Occupant attitudes influencing expectations and comfort.

Attitudes which favour judicious use of active climate control	Attitudes which favour default use of active climate control
<i>Perceived health risks of air conditioning</i>	
Air conditioning is unhealthy	Air conditioning is normal and necessary
Natural ventilation is healthy	Natural ventilation is uncomfortable
Air conditioning is there just for when it is really needed	Air conditioning is the default setting
<i>Impact of the social setting</i>	
I want people to see I care about the environment	There are no social consequences of my using energy
Achieving a low-energy building is everyone's responsibility	Achieving a low-energy building is the responsibility of the building designers and facility manager
Achievement of thermal comfort is my responsibility	The building should provide a thermally comfortable environment
I shouldn't use more than my fair share of energy	The amount of energy consumed is not my concern

I assume others are comfortable without air conditioning; if not they will tell me	Having the air conditioning on is a common courtesy to visitors
I dress for comfort, within reason	I dress for appearance
<i>Impact of the physical setting</i>	
I notice the building does not use energy unnecessarily	I notice the building is wasting energy
The building provides helpful prompts to save energy	The building interferes with my functional needs
The building provides guidance on how I need to operate it	It is not obvious how to operate the building; as a result I sometimes appear foolish
<i>Knowledge of and engagement with the building</i>	
I feel confident operating the building	I feel intimidated by the building's complexity
I am proud of working in this building	This is just a building
I receive meaningful feedback so I know my efforts have an impact	I don't know if the building is living up to its design intent

4.2 Guidelines

The attitudes listed in Table 5 relate to comfort and satisfaction not as a result of the deterministic relationship described in quantitative models, but as a result of socio-cultural constructions, including as a response to the built environment, a response to social conditions, or informed by cultural understandings of 'healthy' and/or 'normal'. Following this line of reasoning, just as built environments can be designed to operate within a certain range of thermal parameters, they can be intentionally designed and managed to influence occupant attitudes in favour of judicious energy consumption, to some degree. This leads to the formulation of tangible qualitative design guidelines for occupant-controlled, low-energy buildings which complement the existing strategies of appropriate passive design, effective adaptive comfort devices, and efficient active systems. The guidelines look at each pair of attitudes and consider whether they can be utilised in design and management.

4.2.1 User experience of building controls

The results identified that aspects of the physical setting had an impact on the occupants' functional and psychological comfort, and that these could lead to the entrenchment of certain attitudes. These attitudes emphasised a desire for the building to actively conserve energy where possible, just as is expected of the occupants, and for it to support the occupants' own efforts by striking the right balance between inconvenience and encouragement, and by being intuitive.

These conclusions are obvious, and have been well-documented by others (e.g. Leaman, 2003), but often not achieved in reality. It is argued that extra attention to detail regarding the inadvertent implications of the user experience is warranted.

In applying this understanding, building controls should be considered in terms of the space's functional relationship to the occupant in terms of whether it is common or working area, and therefore whether the operation of the space is the responsibility of the building or the occupant.

Systems serving common spaces such as bathrooms and circulation are normally the responsibility of the building and therefore automated. They should:

- Ensure energy is not wasted, for example lights which needlessly illuminate well-daylit spaces; and
- Provide visible evidence that remind occupants that the building is operating efficiently.

Systems serving occupants' normal work areas can be placed in the responsibility of the occupant, and should aim to support them by:

- Trusting the occupant to operate them correctly and hence allowing full manual control;
- Providing prompts which remind occupants of their intended use and guide in their correct operation;
- Ensuring any inconvenience factor does not interfere with the functional needs of the occupants; and
- Assuming that occupants will establish a habitual, default setting for their workspace, and that their daily use means occupants can tolerate a greater level of system complexity (within reason).

Systems serving areas used intermittently, such as meeting rooms and function spaces, should aim for a lower level of complexity than areas used regularly, appreciating that occupants will need to be able to operate them intuitively on short notice. They should:

- Include full manual override to allow for immediate changes and future flexibility; and
- Provide instructional labelling.

The issue of assigning responsibility for control in shared workspaces, such as open plan offices, is less clear-cut, and requires special consideration. Further comment is provided in the conclusions.

4.2.2 Organisational expectations

The first set of guidelines requires the designer to consider whether responsibility for control lies with the building or the occupant. Where responsibility is assigned to the occupant, there is an accompanying role for organisational leadership in actively setting expectations accordingly. Once again, this is an obvious statement, but one which in practice is often not acted upon in full.

While many aspects of the social conditions which exist among building occupants cannot be controlled or planned for, organisational leaders can exercise influence. Their goal should be to set an expectation that achievement of comfort is primarily the responsibility of the occupant, and to engage with the design themselves by visibly valuing the quality of a naturally ventilated environment. Obviously, expectations of dress standards must support adaptive comfort needs.

Engagement of organisational leaders in the mixed mode design concept also involves reality-checking; as noted by others (e.g. Chappells and Shove, 2005), organisations need to be clear as to what extent they are willing to go along with unconventional practices, such as relaxed dress codes.

4.2.3 Information and engagement

The third set of guidelines involves effectively engaging the occupants. As with the other guidelines, while this is obvious, it is the inadvertent implications of addressing these needs well (or addressing them poorly) which are of interest here. This is also tied to the readability of the controls. In this case, the focus is on building a sense of

confidence and pride, and taking advantage of existing tendencies. A number of ideas were raised in the results:

- Measures which identify the building as noteworthy, such as unconventional design features, design awards, and the running of building tours can help foster a sense of awareness and pride among occupants, as well as a sense of responsibility in its proper operation;
- Ongoing implementation of such measures can maintain this engagement over time. The building tours were particularly effective in the case of the study building, and were still being conducted three years after initial occupancy, which also helped to engage new staff; and
- Feedback of the building's energy performance should inform occupants of their contribution to measurable goals, and in doing so exploit an existing tendency for individuals to perceive consumption in terms of their 'fair share'.

4.3 Aspects outside the influence of design and management

User-centric consideration of the built environment recognises that both the physical environment and the socio-cultural context influence the user experience. The physical environment can be designed to influence thermal comfort, both in terms of the thermal environment, and as argued here, in terms of its influence on functional and psychological comfort.

There is much more limited opportunity to influence socio-cultural constructions of comfort. However, these results provide a richer understanding of how the social and cultural context influences consideration of comfort, and can assist in selecting the appropriate design approach. These types of themes included:

- Perceptions of the health of air conditioned versus naturally ventilated environments. This should be treated as a folk theory which favours passive design strategies;
- Social consequences, or lack thereof, of using energy conspicuously among the specific user group;
- Self-imposed influence on dress code, which depends on many factors including maintaining a professional image, as shown here, or the surrounding urban context, as emerged from a previous study (Healey and Webster-Mannison, 2012); and
- Social practices of cooling as an act of courtesy.

More novel organisational practices, and the use of innovative engagement strategies such as those using 'fun theory', may have the potential to challenge or encourage these types of cultural norms.

4.4 Constructing a comfort norm

The qualitative measure of success for an occupant-controlled, low energy building in a benign climate zone should be whether natural ventilation is accepted as 'normal' and considered as providing a high quality, desirable work environment. Accordingly, active climate control should be seen as a fall-back position – a method of short-term corrective action.

In the study building, occupants established habits in achieving comfort, constrained by the physical comfort zone, of which humidity was an important determinant in summer. It was also constrained by a number of non-thermal factors as outlined in section 1.1. For most occupants, natural ventilation was entrenched as the default setting, heavily influenced by a perception of healthiness. This created a default work environment where adaptations for air movement (windows and ceiling fans) were

often the first preference in enhancing comfort, for reasons of pleasantness as much as heat balance.

5 Conclusion

The results have demonstrated that through an exploratory approach allowing occupants to discuss comfort in their own words, issues which influence the experience of comfort outside of the deterministic relationship can be identified. These included factors of the physical environment, aspects of the social setting, cultural perception, and organisational influence. These factors can either entrench a culture of energy-judicious behaviour, or of one which accepts and expects the unrestrained use of energy. Some, but not all, of the themes emerging from the results can be of use in achieving a user-controlled mixed-mode building which is judged positively by its occupants. Other themes are outside the influence of design and management but nevertheless add richness to understanding of the relationship between the building, its occupants, and comfort.

A study of a single building and a relatively small group of interviewees is not intended to provide generalisable, repeatable data, but rather to explore thermal comfort from a user-centric and qualitative perspective. In-depth analysis of a single building can reveal aspects not possible by mass survey techniques with predetermined scopes. The results, however, are relevant to the experience of occupant-controlled mixed mode in single-person or low-occupancy offices. Further work within this project will present a similar perspective of open plan workspaces and the more complex design challenge that involves. In adopting a loose research structure, the study has revealed avenues for future research.

Most significantly, the results support the increased use of social research methods in building science. This study used interviews which by nature involve reflection and recollection by occupants. Alternatively, in-situ observational techniques could provide a more reliable source of data. Of particular interest are occupant interactions in group decision making for comfort, with attention paid to the influence of user group size, from two-person offices to large open plan. Some interesting characteristics of group negotiations have been identified previously (Healey and Webster-Mannison, 2012).

The results identified at least three particular groups of occupants; those for whom working in the building had altered their values and behaviour in terms of environmental sustainability, those who felt they were already engaged with the issue and showed little further desire to change, and those who were uninterested or ambivalent. These groups may provide an interesting basis for longitudinal study of pro-environmental behaviour in green buildings. In the context of the research interest presented here, such knowledge may assist in better fitting design concepts to specific user groups.

Finally, there is an implied promise to occupants of low energy buildings, particularly those buildings of unconventional design and operation, that the behaviour changes requested of occupants will result in lower energy use. To many occupants, these behaviour changes are seen as compromises. Additionally, when greater responsibility in operating the building is placed in the hands of occupants, they expect the building performance to uphold the same responsibility; to be comfortable, energy-efficient, and to support their functional needs, and without prioritising energy efficiency over comfort or function. Buildings which fail in fulfilling these expectations not only fail

the occupants, they erode industry confidence in mixed mode, occupant control, and other unconventional low-energy design strategies.

References

Baker, N., & Standeven, M., 1994. Comfort criteria for passively cooled buildings - a PASCOOL task. *Renewable Energy*, 5(5-8), 977–984.

Best, R., & Purdey, B., 2012. Assessing occupant comfort in an iconic sustainable education building. *Australasian Journal of Construction Economics and Building*, 12(3), 55–65.

Brager, G. S., & Baker, L., 2009. Occupant satisfaction in mixed-mode buildings. *Building Research & Information*, 37(4), 369–380.

Brager, G. S., Paliaga, G., & de Dear, R. J., 2004. Operable windows, personal control and occupant comfort. *ASHRAE Transactions*, 110(2), 17–35.

Chappells, H., & Shove, E., 2005. Debating the future of comfort: environmental sustainability, energy consumption and the indoor environment. *Building Research & Information*, 33(1), 32–40.

Deuble, M. P., & de Dear, R. J., 2012. Green occupants for green buildings: The missing link? *Building and Environment*, 56, 21–27.

Haldi, F., & Robinson, D., 2010. On the unification of thermal perception and adaptive actions. *Building and Environment*, 45(11), 2440–2457.

Healey, K., 2014. Measurement and interpretation of thermal comfort in a highly adaptive mixed-mode building. *Architectural Science Review*, 'Latest articles' Published 15 January 2014.

Healey, K., & Webster-Mannison, M., 2012. Exploring the influence of qualitative factors on the thermal comfort of office occupants. *Architectural Science Review*, 55(3), 169–175.

Healey, K., Groenhout, N., Fowler, T., & Merrony, D., 2007. Bond University School of Sustainable Development - successful sustainable design in the subtropics. Australian and New Zealand Solar Energy Society (ANZSES), *Solar '07: Is solar our only nuclear option?* Alice Springs, 3-5 October 2007, Sydney: ANZSES.

Heschong, L., 1979. *Thermal delight in architecture*. Cambridge Mass.: MIT Press.

Hitchings, R., 2009. Studying thermal comfort in context. *Building Research & Information*, 37(1), 89.

Leaman, A. (2003). User needs and expectations. In *Buildings, Culture and Environment: Informing Local and Global Practices*. Oxford, UK: Blackwell Pub.

Roaf, S., Nicol, F., Humphreys, M., Tuohy, P., & Boerstra, A., 2010. Twentieth century standards for thermal comfort: promoting high energy buildings. *Architectural Science Review*, 53(1), 65–77.

Robson, C., 2011. *Real world research: a resource for users of social research methods in applied settings*. 3rd edition. Chichester West Sussex: Wiley.

Strengers, Y., & Maller, C., 2011. Integrating health, housing and energy policies: social practices of cooling. *Building Research & Information*, 39(2), 154–168.

Vischer, J. C., 2008. Towards a user-centred theory of the built environment. *Building Research & Information*, 36(3), 231–240.

Zeisel, J., 2006. *Inquiry by design: environment behavior neuroscience in architecture, interiors, landscape, and planning*. Revised edition. New York: W.W. Norton & Co.

WINDSOR CONFERENCE 2014

COUNTING THE COST OF COMFORT

SESSION 3

Comfort in Offices and Educational buildings

Invited Chairs: Richard de Dear and Sue Roaf

Proceedings of 8th Windsor Conference: *Counting the Cost of Comfort in a changing world* Cumberland Lodge, Windsor, UK, 10-13 April 2014. London: Network for Comfort and Energy Use in Buildings, <http://nceub.org.uk>

Understanding thermal comfort conditions in airport terminal buildings

Alkis Kotopouleas¹ and Marialena Nikolopoulou²

Centre for Architecture and Sustainable Environment (CASE), Kent School of Architecture, University of Kent, Canterbury, CT2 7NZ. Email: ak497@kent.ac.uk

Abstract

This paper presents the results from the thermal comfort studies at three airport terminal buildings in the UK where seasonal on-site surveys were conducted. The investigation involved extensive monitoring of the indoor environmental conditions along with 3,087 questionnaire-guided interviews with terminal users. The paper quantifies the thermal requirements of the terminal population and focuses on the thermal perception of passengers and staff in different terminal spaces. The findings demonstrate the preference for a different thermal environment than the one experienced and that thermal neutrality is found to lie at lower temperatures than those experienced, suggesting an overheating issue, predominantly in winter. Passengers and staff present different satisfaction levels with the indoor environment while their thermal sensation is greatly affected from the characteristics and function of the terminal spaces.

Keywords: airport terminal, passengers and staff, indoor thermal comfort, thermal sensation, thermal preference.

1. Introduction

Airport terminals are a particularly complex building type where the needs of very different population groups are accommodated. The indoor microclimatic conditions are expected to provide a comfortable working environment to the small number of terminal staff and at the same time a comfortable transient environment to passengers. Variations in clothing levels and activity, along with time spent in the area and overall expectations are differentiating factors for variations in thermal requirements between the two groups. The diversity of spaces and the heterogeneous functions across the different terminal zones further contribute to thermal comfort conflicts. Understanding such conflicts can improve thermal comfort conditions, while reducing the large amounts of energy consumed for the conditioning of terminal buildings.

ASHRAE design recommendations for airport terminals are 23-26°C temperature and 30-40% RH in winter and 40-55% RH in summer (ASHRAE, 2003). Allowing for wider temperature ranges, CIBSE provides seasonal comfort criteria for specific terminal areas, based on standard activity and clothing insulation levels as shown in table 1 (CIBSE, 2006).

Table 1: Recommended comfort criteria for airport terminal spaces (CIBSE).

	Summer*	Winter*	
	Operative temperature (°C)		Activity (met)
Baggage Reclaim	21-25**	12-19**	1.8
Check-in areas***	21-23	18-20	1.4
Concourse (no seats)	21-25**	19-24**	1.8
Customs area	21-23	18-20	1.4
Departure lounge	22-24	19-21	1.3

* For clothing insulation of 0.65 clo in summer and 1.15 clo in winter.

** Based on PMV of ± 0.5 . At other cases based on PMV of ± 0.25 .

*** Based on comfort requirements of check-in staff.

However, there are very few published studies on the evaluation of the thermal environment in airport terminal spaces. A study in three Greek airports with 285 questionnaires highlighted the different satisfaction levels between staff and passengers (Balaras et al, 2003). Another study, surveying 128 staff and passengers in the terminal of Ahmedabad airport, India, found a very high comfortable temperature range in the air-conditioned part of the building, 24-32 °C (Babu, 2008). A study with 569 questionnaires from passengers in Terminal 1 at Chengdu Shuangliu International Airport in China reported 95.8% thermal acceptability (Liu et al, 2009).

The current study is the most extensive work available to date. Through field surveys in different terminal areas it investigates and quantifies the thermal comfort requirements using a large population sample from three airport terminal buildings in the UK.

2. Field surveys in airport terminals

On-site surveys were carried out in London City Airport (LCY), Manchester Terminal 1 (MAN T1) and Manchester Terminal 2 (MAN T2). The work involved extensive monitoring of the indoor environmental conditions across the different terminal areas along with questionnaire-based interviews with terminal users. Each terminal was surveyed for a week in summer and winter (2012-2013) to get the seasonal variations.

2.1 Description of terminals surveyed

The selection of the terminals aimed for buildings of different characteristics and capacities. LCY terminal is a compact building with a total floor area of 8,000 m². In 2012, LCY was the 15th busiest airport in the UK serving over 3 million passengers (CAA, 2013). In the same year, Manchester represented the 3rd busiest airport with 20 million passengers (CAA, 2013). The current capacity of MAN T1 and MAN T2 is 11 and 8 million passengers a year (Manchester Airport, 2007). The passenger-related facilities are spread over an area of 43,499 m² in MAN T1 and 26,063 m² in MAN T2, excluding the car parks, mechanical people movers and air bridges.

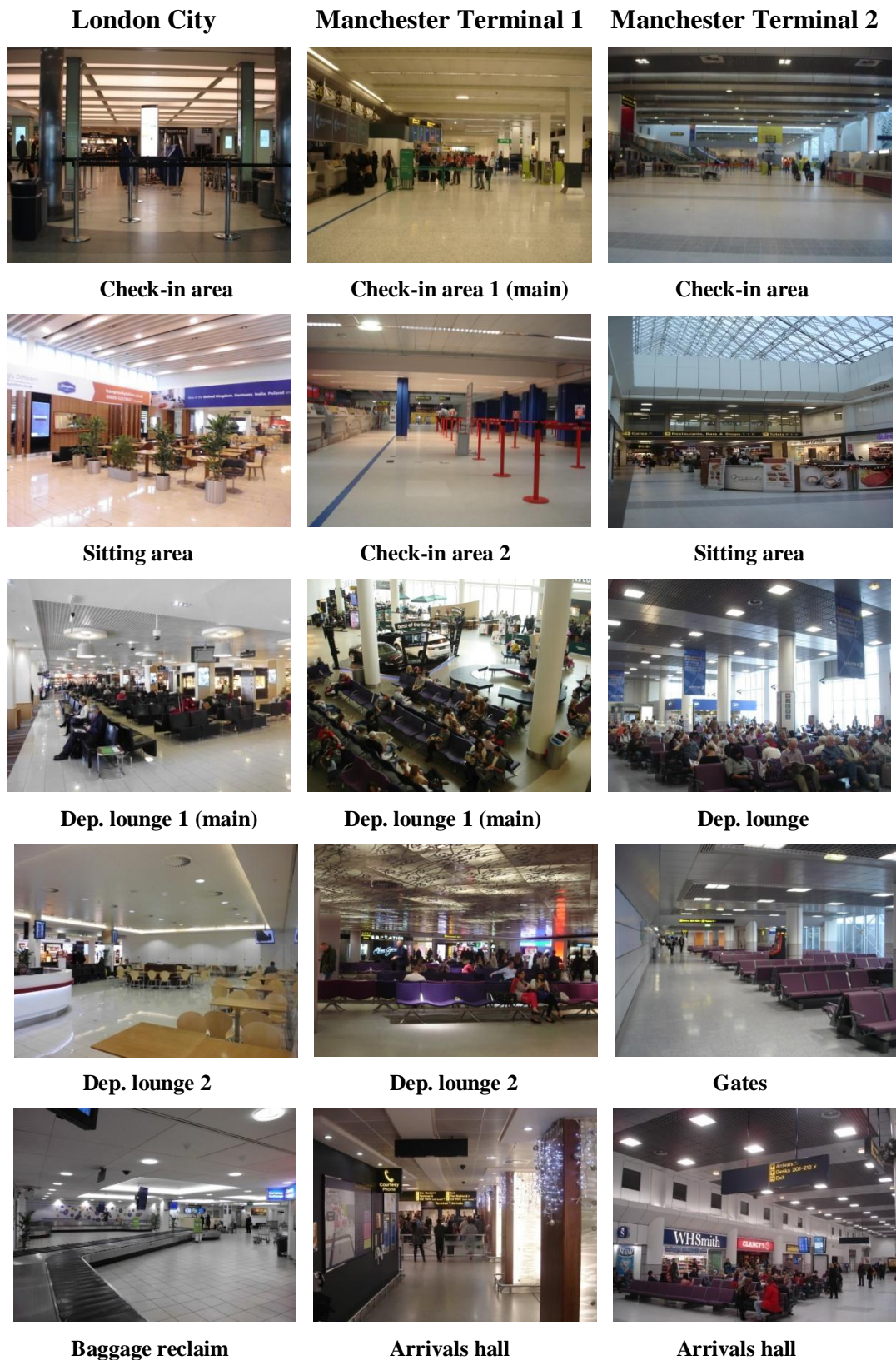

Figure 1: Representative images of spaces in the three terminals surveyed.

MAN T2 features the most contemporary terminal design between the three terminals in Manchester. The vast majority of its passenger-related facilities have high floor-to-ceiling heights with extensive use of natural light through window walls and

rooflights. The gate lounges are the continuation of the departure lounge as they are located at the two diametrically opposed piers spanning from the central building. The largest among the case-studies, MAN T1, has undergone various expansions over the years. As a result, it houses a mixture of heterogeneous spaces (figure 1).

The thermal environment in MAN T1 and MAN T2 is controlled by variable refrigerant volume (VRV) and fan coil unit systems, whereas in smaller areas direct expansion (DX) systems are used. The temperature set-point is kept at 21°C throughout the year. The spaces in LCY are conditioned by 13 air handling units aiming for a temperature set-point of 20°C for winter and 23°C for summer.

Another differentiating factor between the terminals is the dwell time. As a result of its small size and the focus on business passengers, LCY provides short walking distances and significantly shorter dwell times, which can be limited to 20 minutes from check-in to emplaning.

The spaces monitored in each terminal include check-in areas, security search areas, circulation spaces, retail facilities, departure lounges, gates, baggage reclaim and arrivals halls.

2.2 Environmental and human monitoring

The terminals were monitored from 5am - 9pm to get the peak and off-peak times. The monitored physical parameters included dry bulb and black globe temperature, relative humidity, air movement, carbon dioxide and horizontal illuminance levels. All quantities were measured at the average height of a standing person (1.7 m) and recorded at one-minute intervals. The equipment employed conforms to ISO 7726 (ISO, 1998) and consists of a data logging system, a shielded temperature and humidity probe, black globe thermometer, ultrasonic anemometer, a CO₂ sensor and a light sensor. The weather station was designed to be mobile across the terminal spaces and dismountable when passing through the x-ray machines, allowing for the investigation of the immediate microclimate people experience.

The selection of interviewees was random in order to get a representative population sample of passengers, staff, meeters and greeters. The questionnaire aimed for the collection of subjective data for the evaluation of comfort conditions. Thermal sensation was assessed on the 7-point ASHRAE scale while a 5-point scale was used for thermal preference. Similar pattern of questions were used for the perception and the preference over other environmental parameters such as air movement, humidity and lighting levels, while people was also asked to assess their overall comfort state. Additional data collected include the activity levels during and 15 minutes prior to the questionnaire, clothing insulation, time spent in the terminal and demographic data.

3. Data analysis

The data were analysed with the statistical software package SPSS 19. The total sample population (table 2) consists of 3,087 people with a 50:50 male-female ratio. In each terminal the majority of interviewees (70-80%) are transit, arriving and mostly departing passengers. In LCY 52% of departing passengers were travelling on business, whereas this percentage was significantly lower in MAN T1 (14%) and MAN T2 (3%). The average passenger in all terminals is 35-44 years old, similarly to the average employee in MAN T2. Staff in LCY and MAN T1 displays a median age of 25-34. Reflecting the dwell time of terminal staff, 80% of interviewed employees are working full-time and 20% part-time. Airport, airline and retail staff was studied in their work spaces and account for 12-17% of the terminal population. Other

interviewees include meeters and greeters studied in the landside areas of the terminals (check-in and arrivals halls).

Table 2: Number of interviewees in the surveyed terminals.

	Summer	Winter	Total
LCY	403	415	818
MAN T1	663	535	1198
MAN T2	538	533	1071

During the summer surveys the outdoor 24h-mean temperature ranged between 11-20°C in LCY, 15-16°C in MAN T1 and 10-16°C in MAN T2, while the respective winter temperature ranges were 3.9-12°C, 0.9-6.6°C and -1.6-6.3°C. In summer the terminal population had very similar clothing insulation values, while in winter, the effect of outdoor weather resulted in distinct variations in clothing levels between the groups (table 3).

Table 3: Mean clothing insulation (clo) of terminal users.

	LCY		MAN T1		MAN T2	
	Summer	Winter	Summer	Winter	Summer	Winter
Employees	0.64	0.90	0.60	0.79	0.56	0.80
Passengers	0.64	1.15	0.53	1.02	0.50	0.88
Meeters & Greeters	0.67	1.28	0.57	1.04	0.54	1.05

An overview of the indoor environmental conditions for the three terminals is provided in table 4. In LCY the operative temperature presented a narrow range (4.4°C in summer and 3.6°C in winter) as a result of its small size and uniform environment. The lowest and highest temperatures were observed during the low occupancy and peaks respectively. In the bigger MAN T2 the temperature ranged between 20.6 - 26.3°C in summer and 18.9 - 24.5°C in winter. As a result of its diverse spaces, MAN T1 presented the widest temperature range in both seasons (19.1 - 25.4°C in summer and 16.2 - 25.6°C in winter). Despite the fact that all three terminals do not include (de)humidification, the mean RH (%) was found within the ASHRAE recommended range. The occasionally high air movement occurred in spaces exposed to the outdoor wind through the openings, but the mean air movement was very low (0.1- 0.2 m/s).

Table 4: Descriptive values of physical quantities monitored in summer and winter.

		Summer					Winter				
		T _{op.} (°C)	V _{air} (m/s)	CO ₂ (ppm)	RH (%)	Illum. (lux)	T _{op.} (°C)	V _{air} (m/s)	CO ₂ (ppm)	RH (%)	Illum. (lux)
LCY	Mean	23.3	0.12	483	50.4	339	23.4	0.13	817	32.3	300
	SD	0.9	0.06	138	3.0	680	0.6	0.04	152	7.0	390
	Min	21.4	0.04	324	44.7	80	21.7	0.04	660	21.7	70
	Max	25.8	0.58	1095	64.1	7999	25.3	0.26	1333	53.3	3746
MAN T1	Mean	22.0	0.15	648	57.5	260	21.3	0.16	770	32.5	485
	SD	1.5	0.05	172	5.8	223	2.0	0.16	107	5.9	1044
	Min	19.1	0.04	298	46.6	40	16.2	0.03	587	23.2	20
	Max	25.4	0.32	1059	73.8	1854	25.6	1.04	1365	53.1	8173
MAN T2	Mean	23.0	0.18	726	51.1	836	21.1	0.16	752	32.6	480
	SD	1.3	0.11	209	6.8	957	0.9	0.09	159	6.0	536
	Min	20.6	0.04	490	37.6	20	18.9	0.04	284	22.0	40
	Max	26.3	0.55	1380	66.6	6431	24.5	0.49	1273	44.5	3498

3.1 Thermal sensation of the total terminal population

The frequency distribution of actual thermal sensation (TS) and PMV for each terminal is presented in figure 2. The majority of people in LCY (83%) and MAN T1 (78%) reported acceptable TS (middle three categories on the ASHRAE scale) in summer, when “neutral” was the sensation with the highest percentage.

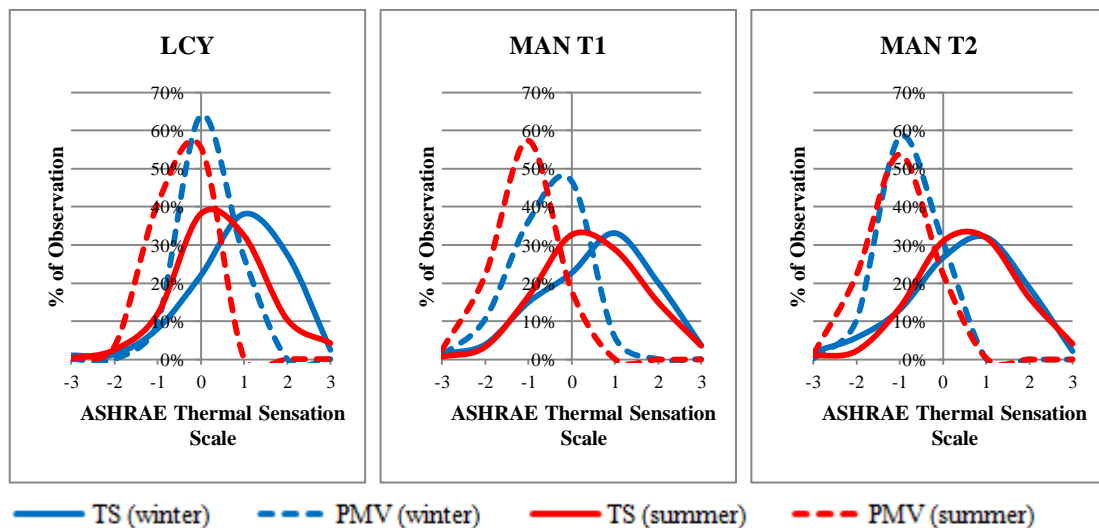

Figure 2: Percentage distribution of actual and predicted thermal sensation.

As a result of the increased clothing insulation in winter, the majority of TSs (87% in LCY and 76% in MAN T1) shifts towards warmer votes. This pattern is similar in MAN T2 in both seasons. Although PMV follows the seasonal shift of TS it predicts cooler TSs in summer and winter, as well as a significantly narrower range of TS in

all three terminals. The mean absolute TS-PMV discrepancy ranges between 1.04 and 1.67 (ASHRAE scale units), and is higher in summer.

Correlation analysis showed that TS shares more variance with operative temperature than with any other of the physical variables, with the associated coefficients being 0.25 for LCY, 0.40 for MAN T1 and 0.20 for MAN T2 (all significant at $p < 0.01$). Using half-degree ($^{\circ}\text{C}$) operative temperature bins, the actual and predicted neutral temperatures were calculated by means of weighted linear regressions (figure 3). The models were also used for the calculation of the temperature ranges in which 80% and 90% of terminal users find the thermal environment acceptable. Thus, in accordance to the statistical assumptions of the PMV/PPD heat-balance model (ISO 7730) it was assumed that a mean TS of ± 0.85 and ± 0.50 corresponds to 80% and 90% general acceptability respectively. All presented models (table 5) achieved a statistical significance level of 99% or better.

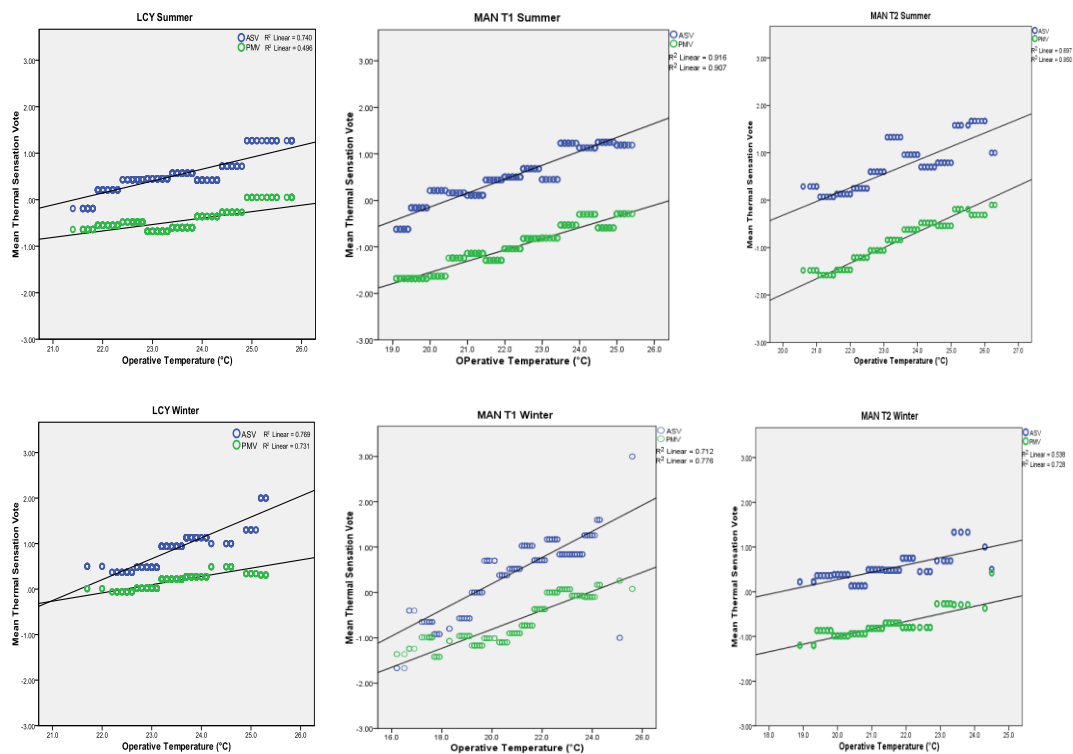

Figure 3: Relationship between actual and predicted thermal sensation with operative temperature.

The gradients of the regression models show that people presented similar thermal sensitivity in all terminals during summer. The temperature change necessary to shift the TS by one unit on the ASHRAE scale is 3.9°C in LCY, 3.4°C in MAN T1 and 3.5°C in MAN T2. In winter the slope varies widely between the terminals: in LCY respondents' thermal sensitivity is greatly increased and the TS change rate is one unit for every 2.2°C temperature change. In MAN T1, there is a similar thermal sensitivity and same rate of TS change with summer, whereas in MAN T2, the mean TS would not be altered with temperature changes below 6.2°C .

Table 5: TS and PMV regression models, neutral temperatures (°C) and acceptability temperature ranges in summer and winter.

		Slope	R ²	T _{neutral} (°C)	80% accept. (°C)	90% accept. (°C)	
Summer	Actual	LCY	0.256	0.74	21.4	18.1 – 24.8	19.5 – 23.4
		MAN T1	0.300	0.92	20.4	17.6 – 23.3	18.8 – 22.1
		MAN T2	0.289	0.70	21.1	18.2 – 24.1	19.4 – 22.9
	Predicted	LCY	0.139	0.50	26.8	20.7 – 32.9	23.2 – 30.4
		MAN T1	0.241	0.91	26.4	22.9 – 29.9	24.3 – 28.5
		MAN T2	0.327	0.95	26.1	23.5 – 28.7	24.6 – 27.6
Winter	Actual	LCY	0.459	0.77	21.5	19.7 – 23.4	20.4 – 22.6
		MAN T1	0.288	0.71	19.4	16.4 – 22.3	17.6 – 21.1
		MAN T2	0.163	0.54	18.3	13.1 – 23.6	15.3 – 21.4
	Predicted	LCY	0.181	0.73	22.5	17.8 – 27.2	19.7 – 25.2
		MAN T1	0.209	0.78	23.9	19.9 – 28.0	21.5 – 26.3
		MAN T2	0.170	0.73	25.9	20.9 – 30.9	22.9 – 28.8

In all cases the results reveal that neutral temperatures lie below the mean operative temperature people experience. In summer, neutrality temperature is lower by 1.6 °C in MAN T1 and by 1.9 °C in LCY and MAN T2. Despite the increased thermal sensitivity in LCY during winter, the neutral temperature is the same in both seasons and consistently lower than the mean operative temperature by 1.9 °C. In MAN T1 and MAN T2, neutrality in winter is lower than the mean operative temperature by 1.9 °C and 2.8 °C. On the other hand, PMV regression models predict significantly higher neutral temperatures by 1.0-7.6 °C.

Figure 4 shows the operative temperature together with the 80% and 90% acceptability temperature ranges. During the summer surveys the temperature lies within the 80% acceptable range for 94%, 82% and 73% of the monitoring time in LCY, MAN T1 and MAN T2. This is also the case during winter in MAN T2 (99% of time), whereas in LCY and MAN T1 the temperature in winter remains within that range for only 48% and 66% of time, highlighting periods of overheating, as is also apparent from the thermal sensations in figure 2.

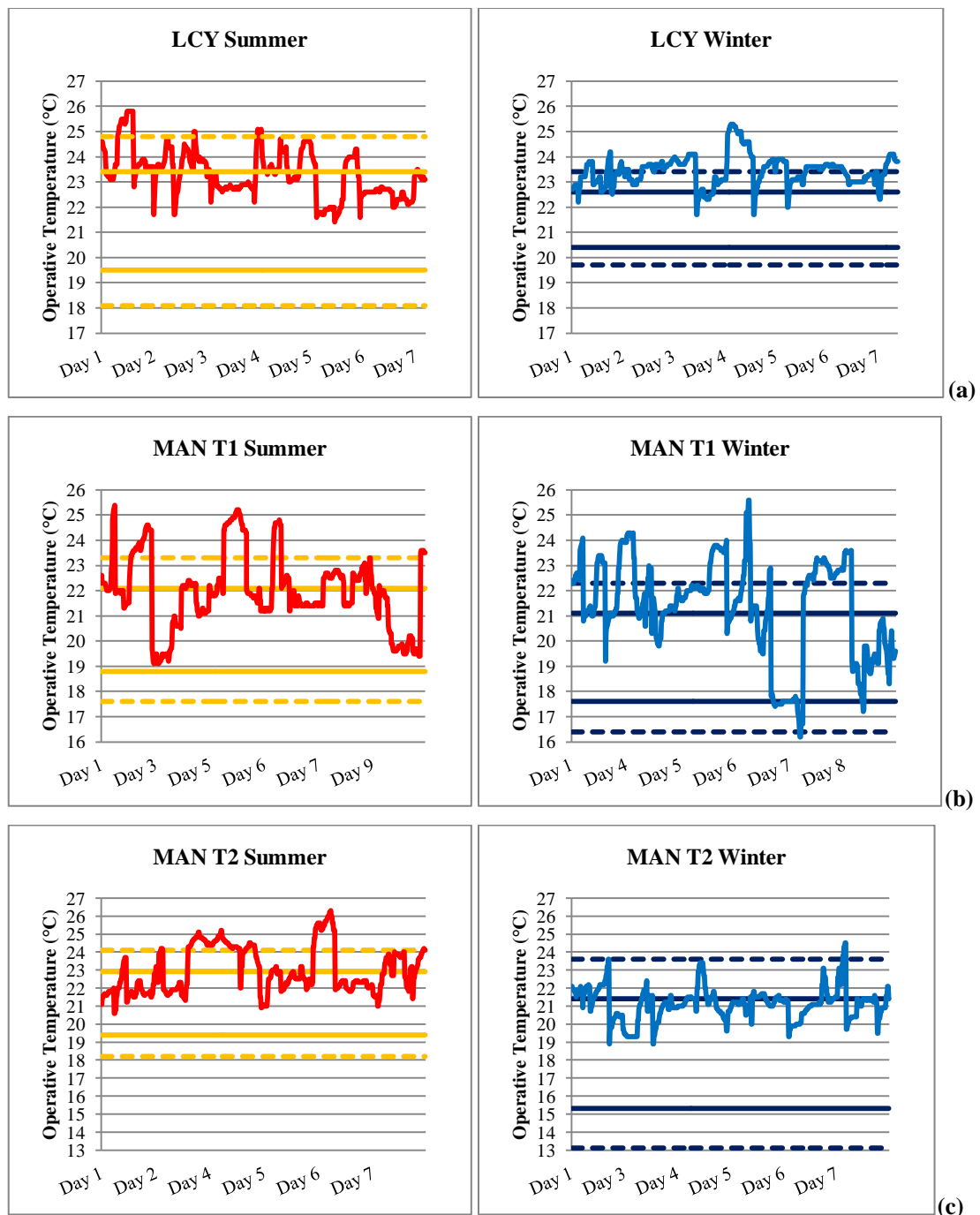

Figure 4: Operative temperature, 80% (dotted lines) and 90% (continuous lines) acceptability temperature ranges in (a) LCY, (b) MAN T1 and (c) MAN T2.

Interestingly, it was found that “neutral” is not the desired TS for the majority of passengers or staff. Assuming that those who voted “no change” in the thermal preference scale are satisfied with the thermal environment, the results show that 51%, 64% and 58% of passengers in LCY, MAN T1 and MAN T2 had reported a TS other than neutral. Similarly, 53%, 57% and 60% of the satisfied with the thermal environment staff in LCY, MAN T1 and MAN T2, had reported non-neutral TS.

3.2 Thermal preference

The correlation coefficients between thermal preference and operative temperature are 0.27, 0.41 and 0.40 for LCY, MAN T1 and MAN T2 respectively ($p < 0.01$). For the analysis, thermal preference (TP) was transformed into a 3-point variable. Thus, the preferences for a “much cooler” and “a bit cooler” environment are represented by “prefer cooler” and those for a “much warmer” and “a bit warmer” environment by “prefer warmer”.

In summer the thermal preference profile is very similar in all terminals, where approximately 50% of interviewees desire no change and nearly 40% prefer cooler conditions (figure 5). In winter the majority of people (53%) in LCY prefer to be cooler. In MAN T1 almost half find the thermal environment ‘just right’, however the percentage of those preferring to be warmer is almost twice of that in summer. People in MAN T2 display the highest thermal satisfaction from all terminals as nearly 60% requires no change.

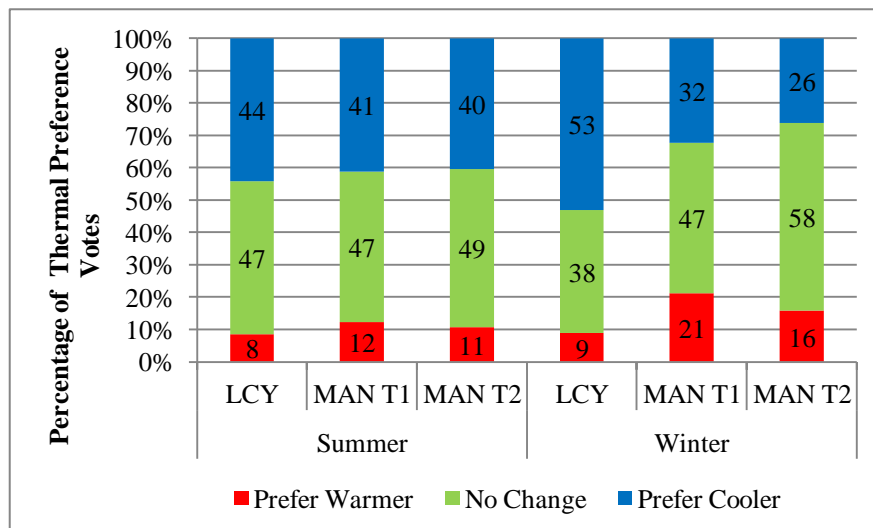

Figure 5: Percentage of binned thermal preference votes.

In order to quantify the preferred temperatures, weighted linear regressions were fitted separately between the “prefer warmer” and “prefer cooler” percentages and the operative temperature. Preferred temperature is obtained from the intersection of the two regression lines (figure 6).

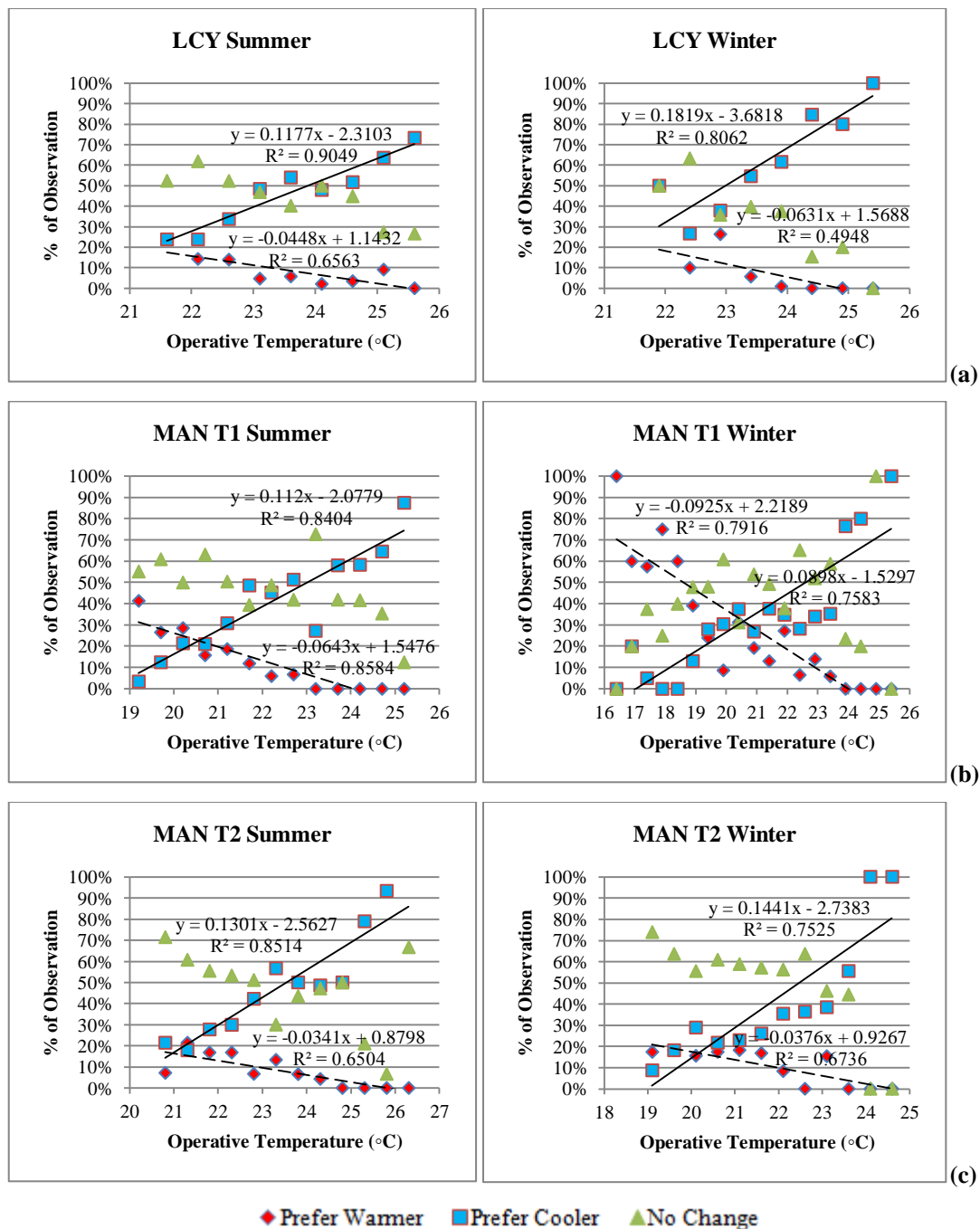

Figure 6: Calculation of preferred temperatures in (a) LCY, (b) MAN T1 and (c) MAN T2 in summer and winter.

The profile of preferred temperatures (table 6) follows that of the neutral temperatures and in most cases the two almost coincide. The results demonstrate the preference for cooler temperatures than those experienced in all terminals in both seasons. They also provide evidence of tolerance under cooler conditions; in MAN T1 and MAN T2 where the lowest indoor temperatures occurred during winter, the preferred temperature was 20.6 °C and 20.2 °C, while neutral temperature was 19.4 °C and 18.3 °C respectively. The preferred temperatures in LCY are found below the minimum temperature experienced (table 4), suggesting an overheating issue, more pronounced during winter.

Table 6: Summary of mean, neutral and preferred operative temperatures.

(°C)	Summer			Winter		
	LCY	MAN T1	MAN T2	LCY	MAN T1	MAN T2
Tmean	23.3	22.0	23.0	23.4	21.3	21.1
Tneutral	21.4	20.4	21.1	21.5	19.4	18.3
Tpreferred	21.3	20.6	21.0	21.3	20.6	20.2

3.3 Satisfaction of passengers and staff with the indoor environment

With a focus on the two major terminal population groups, the thermal comfort requirements were investigated separately for passengers and staff. The results demonstrate the different thermal requirements between the two groups, as discussed by Kotopoulos and Nikolopoulou (2014). Employees are on average 1.6 times more sensitive to temperature changes than passengers in both seasons, while both groups have neutral at temperatures lower than the mean temperature they experience. However, the acceptability range for staff is narrower, with neutral temperature higher than passengers' by 0.6-3.9 °C. The results also suggest that both groups prefer a cooler environment. Interestingly, passengers are more tolerant of cooler conditions, whereas employees prefer warmer temperatures than passengers by 0.4-1.4 °C in summer and 1.1-2 °C in winter. The diversity in comfort requirements is also reflected in the significantly higher percentages of uncomfortable employees (23-49%) as opposed to passengers (8-21%).

Examining the overall satisfaction, the staff has lower satisfaction levels with the indoor conditions (figure 7). For the assessment of the satisfaction with the air movement and thermal comfort it was assumed that people who voted "no change" in the corresponding preference questions are satisfied with the respective conditions. The results demonstrate that in all terminals 2/3 of employees are dissatisfied with the thermal environment, while 60-80% prefer either higher or lower air movement in their workspace. Widespread among the employees is also the assessment of the indoor air as "stuffy", as expressed from 40-60% of staff. Similar percentages of dissatisfaction are reported with the lighting environment.

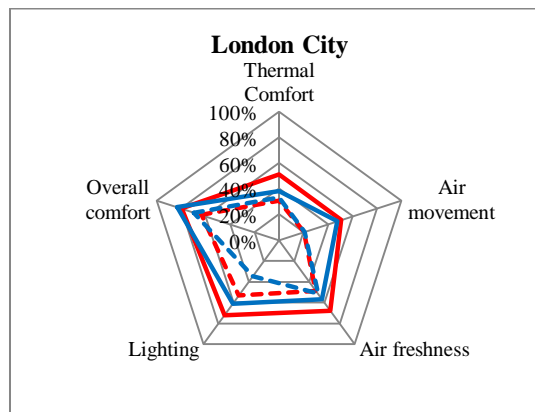

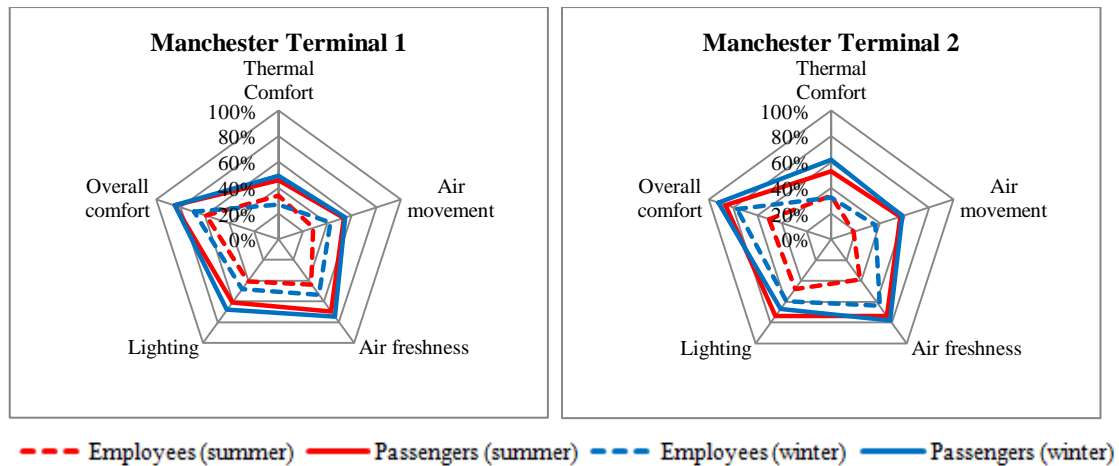

Figure 7: Satisfaction levels of passengers and terminal staff with the indoor conditions in summer (S) and winter (W)

3.4 Thermal conditions in different terminal spaces

An overview of the thermal conditions in the monitored terminal spaces is provided in table 7, where spaces are listed in the order met by a passenger. The mean temperatures in LCY are representative of the uniform thermal environment across the spaces. The exception is the retail area in the summer, which is warmer due to the extensive spot lighting from the very low ceiling resulting in higher temperatures. The gates also vary greatly, as they have free-running conditions.

Thermal uniformity is also found between the airside spaces (beyond the search area) of MAN T2 in summer, with the highest mean temperature difference (only 1.1 °C) found between the sitting area and the gates. Higher temperature (23.7 °C) was found in the search area due to the ineffective conditioning of the space during the occupancy peaks in the busy summer period. However, the highest mean temperature in summer (24.6 °C) occurred in the check-in area. Although it is the largest of all spaces and occupancy peaks should not have a substantial effect on its thermal environment, it has the highest mean temperature due to the extensive use of glazing. In winter, when the external heat gains have a minor effect, all spaces in MAN T2 presented similar mean temperatures (maximum difference is 1.6 °C between the sitting area and the departure lounge). This is also due to the operational profile of MAN T2 during winter, which serves mostly holiday destinations and was significantly busier during the summer monitoring period. Consequently, in winter there were prolonged periods of time with very low occupancy resulting in uniformly lower temperatures very close to the winter indoor temperature set-point (21.0 °C).

On the other hand, the variety of spaces in MAN T1 is reflected in the diverse thermal environments, presenting the highest temperature differences. The arrivals hall was on average 4.7 °C cooler than the departure lounge 1 in summer and 6.2 °C cooler than the sitting area in winter. The particularly lower mean temperatures in the arrivals (19.8 °C in summer and 17.4 °C in winter) are a result of its great exposure to the outdoor conditions. Additionally, departure lounge 1 is constantly warmer than the nearby departure lounge 2 located few meters away, with the highest mean temperature difference between them (2.5 °C) being met in summer, a result of the extensive glazing in the former.

Table 7: Summary of minimum, maximum and mean operative temperature (°C) in each terminal space.

	Summer		Winter		
	Min - Max	Mean	Min - Max	Mean	
	T _{op} (°C)	T _{op} (°C)	T _{op} (°C)	T _{op} (°C)	
LCY	Check-in	21.4 - 25.0	22.7	21.7 - 23.9	23.4
	Search area*	23.2 - 23.7	23.4	22.2 - 23.2	23.0
	Sitting area	22.0 - 24.6	23.2	22.0 - 23.8	23.1
	Dep. Lounge 2	21.7 - 24.2	23.1	21.7 - 23.3	22.9
	Retail*	23.2 - 25.1	24.6	22.8 - 24.2	23.5
	Dep. Lounge 1	21.6 - 25.8	23.9	22.3 - 25.3	23.9
	Gates (west pier)**	24.4 - 25.6	25.1	12.7 - 21.1	18.1
	Baggage reclaim	23.2 - 24.3	23.9	22.3 - 24.1	23.2
MAN T1	Check-in 1	21.2 - 24.6	22.3	20.1 - 22.2	21.7
	Check-in 2	21.3 - 22.8	22.4	21.8 - 23.3	22.8
	Search area	22.1 - 22.6	22.4	21.4 - 24.0	23.4
	Circulation	21.5 - 22.4	22.0	22.3 - 23.9	23.2
	Sitting area	21.0 - 22.6	21.5	22.4 - 24.3	23.6
	Dep. Lounge 2	21.7 - 22.6	22.0	19.2 - 23.3	21.2
	Retail*	22.1 - 23.3	22.6	20.6 - 23.0	22.2
	Dep. Lounge 1	22.9 - 25.4	24.5	19.5 - 25.6	21.9
	Pier C (beg.)	22.4 - 23.1	22.6	19.2 - 21.1	19.8
	Pier C (gates)	20.3 - 22.6	21.6	17.2 - 20.4	18.9
	Pier B (gates)	20.9 - 21.3	21.1	19.4 - 20.9	20.2
	Arrivals hall	19.1 - 21.0	19.8	16.2 - 17.9	17.4
MAN T2	Check-in	23.4 - 25.2	24.6	18.9 - 21.8	21.0
	Search area	21.4 - 24.5	23.7	18.9 - 23.4	21.3
	Sitting area	20.9 - 22.9	21.9	19.3 - 22.1	20.0
	Retail*	21.3 - 23.2	22.4	20.0 - 23.1	21.4
	Dep. Lounge	20.6 - 26.3	22.7	19.6 - 24.5	21.6
	Gates	21.0 - 25.6	23.0	19.5 - 22.6	21.1
	Arrivals hall	21.8 - 22.5	22.2	20.6 - 21.6	21.1

* Based on staff responses predominantly

** Environmental monitoring without questionnaires

CIBSE's comfort criteria (table 1) allows for a comparison of the basic terminal spaces. In winter, all the departure lounges and check-in areas presented a higher mean temperature than the corresponding recommended ranges. More specifically, the mean temperature in the large check-in areas of MAN T1 (check-in 1) and MAN T2 are 1.7 °C and 1.0 °C higher, while significantly warmer are the smaller-sized

check-in spaces in LCY and MAN T1 (check-in 2); 3.4°C and 2.8°C higher than the CIBSE range. In summer, the mean temperature in all departure lounges and the check-in areas is within or very close to the recommended range. Unique exception is the check-in area in MAN T2, which due to the high external heat gains during summer it presents a significantly warmer environment beyond the range. The search areas of all three terminals are regarded as concourse areas with no seating, and they meet the corresponding temperature range in both seasons. Similarly, the thermal conditions in the LCY baggage reclaim area are found within the seasonal range.

Figure 8 illustrates the mean temperature and TS separately for passengers and staff in the different terminal areas monitored. It is evident that in all three terminals employees' TS profile fluctuates significantly between the spaces, contrarily to passengers who present a more stable TS profile. This demonstrates passengers' wider adaptive capacity opposed to the rigid working conditions of staff, as the vast majority of staff (86-94%) at each terminal reported no control over the indoor environmental conditions.

Additionally, employees' TS profile does not always follow the temperature profile across the terminal spaces, i.e. staff in spaces with lower temperature may experience higher TS than in warmer spaces. This reflects the diverse activity levels between the different types of staff. For instance, security staff working in the search area of LCY in summer experienced a mean temperature of 23.4°C and reported a mean TS of 1.7. In the nearby sitting area with just 0.2°C higher temperature staff's mean TS is -0.5, while inside the warmer retail facilities (24.6°C) staff reported neutral TS. The results for MAN T1 and MAN T2 also show that security employees in search areas have higher mean TS than check-in and retail staff in both seasons (figure 8b & 8c).

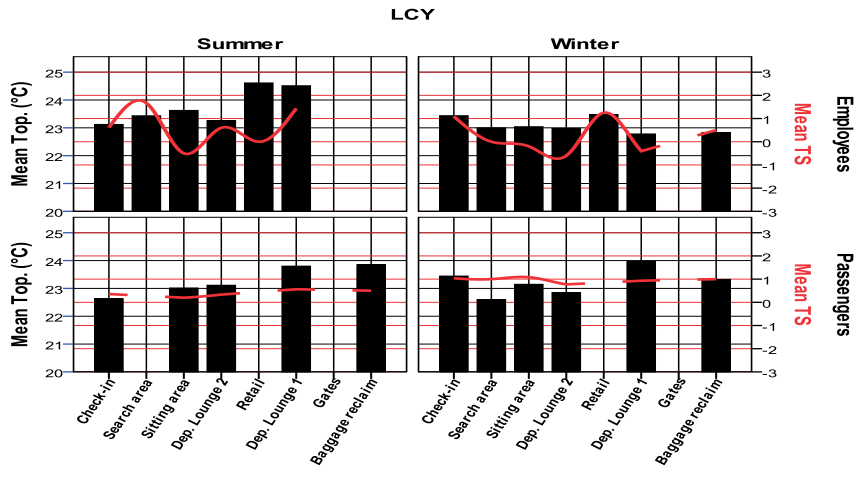

(a)

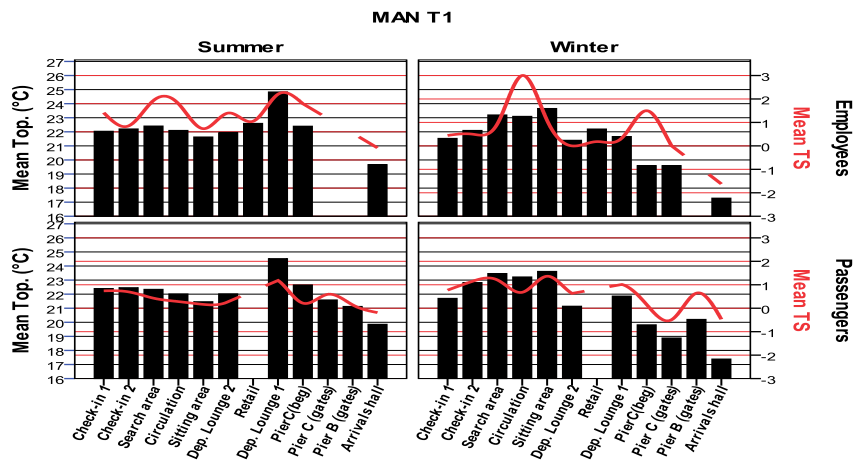

(b)

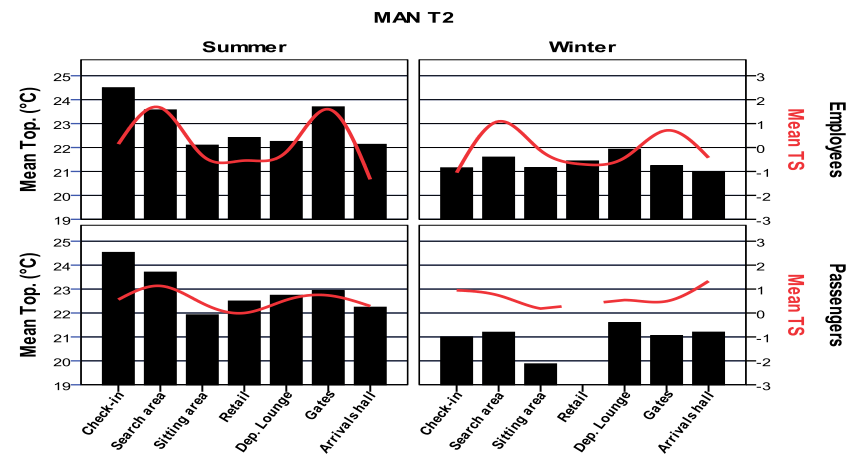

(c)

Figure 8: Mean operative temperature (bars) and thermal sensation (lines) for passengers and staff in the monitored spaces of (a) LCY, (b) MAN T1 and (c) MAN T2. Missing bars indicate insignificant number of questionnaires from the given population group in the corresponding space.

The data analysis also showed that in spaces with highly variable occupancy (e.g. check-in areas and departure lounges) CO₂ levels followed the occupancy patterns. In these spaces higher temperatures occurred during the occupancy peaks, as suggested

from the relevant Pearson correlation coefficients (0.62 in summer and 0.55 in winter for LCY, 0.29 for MAN T1 and 0.37 for MAN T2 in summer, $p < 0.01$). Moreover, the correlation coefficients between CO₂ concentrations and TS (0.23 in LCY and 0.24 in MAN T2, $p < 0.01$) indicate that in the overcrowded spaces TS had an increasing trend (figure 9) resulting in decreased levels of overall comfort.

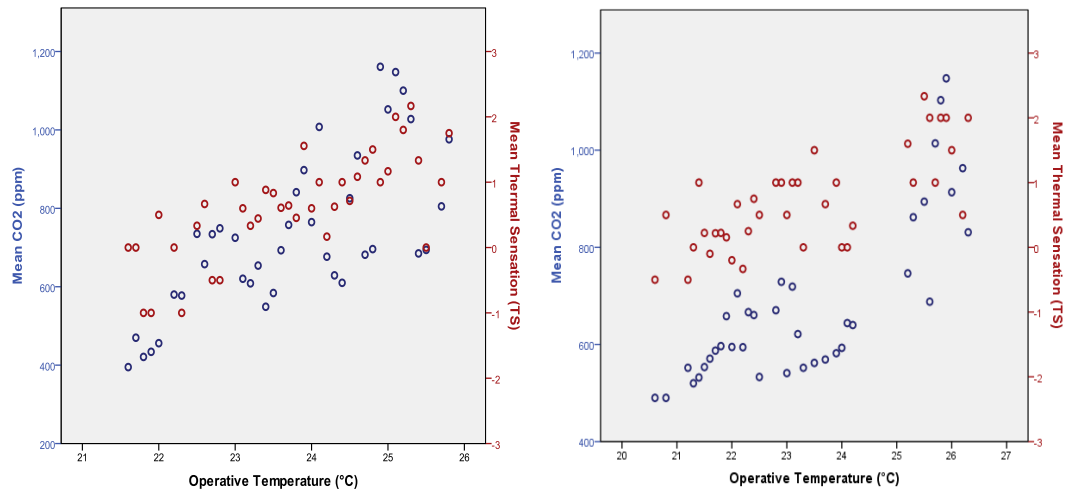

Figure 9: Relationship of CO₂ levels (occupancy), operative temperature and thermal sensation in LCY departure lounge 1 (left) and in MAN T2 departure lounge (right), based on summer and winter data.

4. Discussion

The data analysis showed that the thermal conditions in the three surveyed terminals regularly do not meet people's thermal requirements. In most cases more than half of the terminal population prefers a thermal environment other than the one experienced (figure 5). When compared to the criteria for 80% and 90% acceptability of temperature range (figure 4), the thermal profile of the terminals is predominantly closer to the upper limit and often surpasses it (figure 4), suggesting that the warm environment can be an issue for the terminal population in both summer and winter. The results reveal that cooler temperatures by 0.7-2.1 °C are preferred, while thermal neutrality is found 1.6-1.9 °C lower than the mean indoor temperature in summer and lower by 1.9-2.8 °C in winter (tables 5 & 6).

There are also consistent differences between the satisfaction levels of passengers and staff, with the latter group more sensitive to temperature changes. Differences in their adaptive capacity, restricted clothing levels with lack of control over their thermal environment result in employees' significantly lower satisfaction levels with the indoor environment (figure 7). In all terminals, staff's mean TS fluctuates more between the different spaces in summer and winter (figure 8). For passengers neutrality is achieved at cooler temperatures (by 0.6-3.9 °C) than for employees. For the latter, neutral temperature is also below the mean indoor temperature but closer to it as a result of the long-term acclimatisation to the indoor environment. Similarly, passengers' preferred temperatures are 0.4-2 °C lower than staff's with the highest differences found in winter.

The design of terminal spaces is a very important parameter influencing the thermal environment. Due to its compact nature, LCY presents a uniform thermal environment throughout. The indoor conditions are greatly influenced by the occupancy levels, as shown for the departure lounge in figure 9. The high percentage of people preferring a cooler environment (44% in summer and 53% in winter) suggests a problem with overheating, while, the neutral and preferred temperatures lie below the narrow temperature range of the terminal (table 4 & 6). Overheating was more pronounced in winter, when LCY was busier and passengers' clothing insulation was significantly higher (table 3). Occupancy levels were also a contributing factor to the higher temperatures in the majority of spaces in MAN T2 during summer, although the most important factor appears to be the extensive use of glazing. The high mean temperatures in the check-in area (24.6 °C) and gates (23°C) are representative of the effect of the external heat gains on the indoor environment in summer (figure 8c).

MAN T1 has the widest variety of spaces and respective temperature differences between the spaces in both seasons. Characteristic are the low mean temperatures in the arrivals halls which led to mean thermal sensations on the cool side of the ASHRAE scale in both seasons (figure 8). On the other hand, at the departure lounge 1 passengers experience on average 2.5 °C higher mean temperature than the nearby departure lounge 2 in summer, due to the sunlight entering from the extensive glazing.

Conclusions

This work investigated the breadth of thermal comfort conditions in three airport terminals with different design characteristics and capacities. The indoor environment was extensively monitored in the different terminals' areas where in total 3,087 people were interviewed for the evaluation of the comfort conditions.

The results revealed the discrepancies between the preferred thermal conditions and those experienced. In both seasons, neutrality was found in lower temperatures than the indoor mean temperature for both passengers and staff, while the preference for a cooler thermal environment was demonstrated. The data analysis also showed the variety of the thermal environments experienced in the terminals, as a result of the different design characteristics and functions. Spaces where higher activity levels are performed resulted in higher mean TS. Additionally, higher temperatures and thermal sensations were also found in spaces with extensive sources of sunlight during the summer monitoring period.

The temperature ranges at which 80% and 90% of the terminal population would find the indoor thermal environment acceptable were presented and showed that they were not regularly met. Based on the 80% acceptability ranges, the results indicate that in winter, when overheating was more apparent, there may be a great potential for energy savings from lowering the heating systems set-points without compromising the thermal comfort conditions.

This study aimed to shed light on the thermal comfort conditions in airport terminal spaces and to quantify the thermal requirements of the terminal population. Such knowledge can be useful in improving thermal comfort while different energy conservation strategies are implemented, as well as in the regular refurbishments of existing terminal facilities and the design of new terminal buildings.

Acknowledgments

This work has been funded by the UK Engineering and Physical Sciences Research Council (EPSRC) as part of the project “Integration of active and passive indoor thermal environment control systems to minimize the carbon footprint of airport terminal buildings”, grant no. EP/H004181/1. The assistance from the airports’ authorities and terminal staff at the three surveyed terminals is gratefully acknowledged.

References

- ASHRAE, 2003. Chapter 3: Commercial and Public Buildings, *HVAC Applications Handbook*, American Society of Heating, Refrigerating and Air-Conditioning Engineers Inc., Atlanta, GA.
- Balaras, C.A., Dascalaki, E., Gaglia, A., Drousta, K., 2003. Energy conservation potential, HVAC installations and operational issues in Hellenic airports. *Energy and Buildings*, 35, 1105-1120.
- Babu, A.D., 2008. A Low Energy Passenger Terminal Building for Ahmedabad Airport, India. In *Building Envelope as an Environment Regulator, Proc. PLEA 25th Conference on Passive and Low Energy Architecture*, Dublin, 22nd to 24th October 2008.
- CIBSE, 2006. Chapter 1: Environmental criteria for design, *Guide A, Environmental Design*,. London: The Chartered Institution of Building Services Engineers, Seventh edition.
- CAA, 2013. *UK Airport Statistics*, Civil Aviation Authority, <http://www.caa.co.uk/>
- ISO 7726, 1998. *Ergonomics of the Thermal Environment - Instruments for Measuring Physical Quantities*, Geneva.
- Kotopouleas, A., Nikolopoulou, M., 2014. Airport terminal buildings: Indoor or transitional spaces? *CIBSE ASHRAE Technical Symposium*, Dublin, Ireland 3-4 April 2014.
- Liu, J., Yu, N., Lei, B., Rong, X., Yang, L., 2009. Research on indoor environment for the terminal 1 of Chengdu Shuangliu International airport. *Proc, Eleventh International IBPSA conference*, Glasgow, Scotland, 27–30 July, Building Simulation.
- Manchester Airport, 2007. *Manchester Airport Master Plan to 2030*,.p.55-56.

Occupant behaviour and obstacles in operating the openings in offices in India

Madhavi Indraganti^{#1}, Ryoza Ooka², Hom B Rijal³, Gail S Brager^{1,4}

[#] Fulbright- Nehru Post-doctoral Researcher

¹ Center for the Built Environment, University of California, Berkeley, 390 Wurster Hall, Berkeley, USA

² Department of Human and Social Systems, Institute of Industrial Science
4-6-1, Komaba, Meguro-ku, The University of Tokyo, Tokyo 153-8505, Japan, email:
ooka@iis.u-tokyo.ac.jp

³ Department of Restoration Ecology & Built Environment, Tokyo City University,
Yokohama, Japan, email: rijal@tcu.ac.jp

¹main@berkeley.edu & maindraganti@gmail.com

⁴gbrager@berkeley.edu

Abstract

There is limited information available about occupant's window opening behaviour in India. Operating doors and windows is a vital adaptation mechanism in warm climates. This paper reports on a field study which collected and analysed data on the use of openings, comfort responses and the simultaneous temperatures in Indian offices. Occupants in naturally ventilated buildings used the windows and doors adaptively as the seasons changed and the temperature varied. We found that 50% of the windows would be opened at an indoor air temperature of 30 °C, using logistic regression. We noted some non-thermal factors possibly affecting the adaptive operation of controls as well, including: design and construction, operation and maintenance, environmental socio-cultural, attitudinal, and behavioural aspects. For example, in a few offices, attendants customarily operated the windows instead of occupants. A window's potential for modifying or adapting to their comfort temperature hinges on the effective handling of these hurdles.

Keywords: Thermal comfort; India; Occupant behaviour; Adaptive model; Window opening

1 Introduction

Natural ventilation was predominantly used in commercial buildings in India for building cooling until about the mid-1970s. Economic affordability and availability of air-conditioning (AC) systems increased the use of mechanical cooling in buildings in the last quarter century. In this decade, this has become a default practice. The engineers now have the ability to provide for any desired indoor environment irrespective of the outdoor climate, albeit at an exorbitant first cost and energy expenditure. This has in general freed the architects from the ingenuity of designing the building envelope as a breathing entity.

Research has shown that buildings with natural ventilation systems like operable windows have improved occupant satisfaction and operating costs compared to the AC buildings (Brager, 2006; Leaman & Bordass, 1997; Abbaszadeh, et al., 2006; de Dear & Brager, 1998; Rijal, et al., 2008a; Baker & Standeven, 1996). India is facing unprecedented power shortages in the last five to six years. Building occupants grapple with two-hour daily outages almost

round the year in South India. As a result, natural ventilation systems and mixed-mode building operation are gaining importance in India.

Occupants' ability to responsibly control the operable windows in a naturally ventilated building plays a vital role in the building's performance. Having acknowledged the health, cost and comfort benefits of operable windows some of the recent research energy in the west has been directed towards: (1) the modelling the occupant behaviour in window operation (2) temporal and behavioural patterns in use of environmental controls (3) examination of behavioural control strategies in using the window signalling systems in offices and (4) occupants' perception of use of windows (Rijal, et al., 2013; Haldi & Robinson, 2008; Ackerly & Brager, 2013; Brager & Pigman, 2013; Yun & Steemers, 2008).

However, information on the occupant behaviour in Indian offices is not available in the current literature. Field studies in Indian offices so far have reported on the adaptive model, comfort temperature and seasonal variations, and the use of fans (Sharma & Ali, 1986; Indraganti, et al., 2013; Indraganti, et al., 2014). Therefore, this paper briefly discusses the survey environments, thermal conditions and the adaptive model first. It then focuses on the window operation, occupant behaviour and operational obstacles as observed through a field study in office buildings in India.

2 Field Study

We conducted a thermal comfort field study in 28 office buildings in two capital cities of Chennai (Tamil Nadu) and Hyderabad (Andhra Pradesh) in India for fourteen months from January 2012 to February 2013. Chennai (N13°04' and E80° 17' and 6.7 m above the mean sea level) has a warm humid wetland coastal climate. Hyderabad (N17°27' and E78° 28' and 540 m above the mean sea level) has a composite climate, with hot-dry summer. Both cities have six months of monsoon. These two climates cover about 80% geographical area of the country.

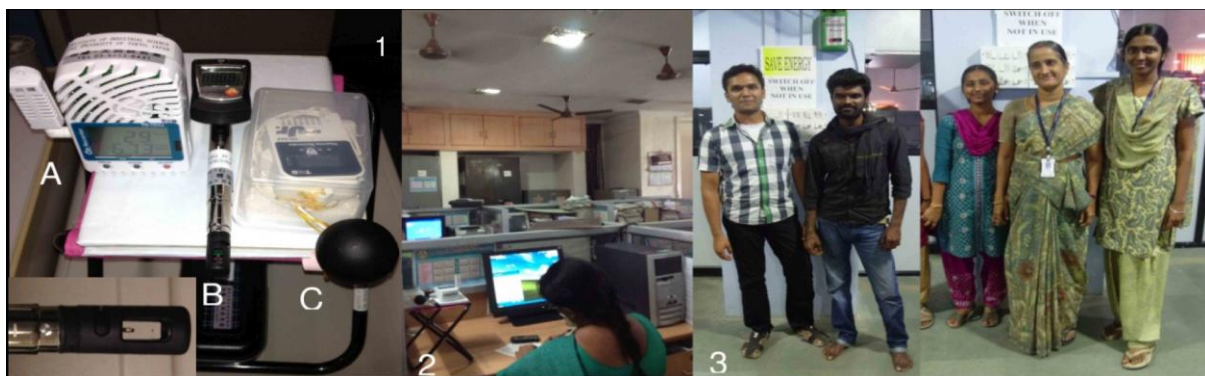

Figure 1. (1) The instrument setup (inset: anemometer sensor tip); (2) The survey environments and (3) typical male and female subjects; (A): Thermo-hygro CO₂ meter; (B) Hot wire anemometer; (C) Globe thermometer

The indoor air temperature, globe temperature (T_g), air velocity, the relative humidity and CO₂ concentration were recorded, close to the subjects at 1.1m level from the ground. We used high precision calibrated digital instruments for measurement, while the subjects filled in the thermal comfort questionnaire in all the 28 office buildings (Fig.1 and Table 1). We noted the readings after 7-10 mins of their settling. Each office was visited once or twice a month at an interval of three to five weeks.

We collected 6048 responses from 2787 individuals (2157 males and 630 females). The average age of the subjects was 31.4 yrs. The age profile is similar in both the genders. The methods are described in greater detail in Indraganti et al. (Indraganti, et al., 2013).

The office buildings were operated in naturally ventilated (NV) (i.e. without mechanical cooling) and air-conditioned (AC) (i.e. with mechanical cooling) modes. Some of the buildings functioned only in AC mode. During the power outages AC systems in a few of these buildings could not be run, while the building could not be run in NV mode either. The data collected during such a condition was labelled as AC_{off} mode. About 10% of the total data were collected in AC_{off} mode. It is imperative to note that window usage was found to be very limited (less than 1%) in AC mode. We did not observe any office using mechanical space heating during the entire survey. In NV and AC modes we collected 1352 and 4310 sets of data respectively. We used only the NV mode data in this paper.

Table 1: Details of the instruments used for the environmental measurement

Description	Trade name	Parameter Measured	Range	Accuracy
Thermo-hygro-CO ₂ meter	TR-76Ui	Air temperature	0 to 45 °C	±0.5 °C
		Humidity	10 to 90 %RH	±5 %
		CO ₂ level	0 to 5,000 ppm	± 50 ppm
Probe thermometer with black painted table tennis ball	Tr-52i	Globe temperature	(- 60 to 155 °C)	±0.5 °C
Hot wire anemometer	Testo -405	Air velocity	0.01-50.0 m/s	± 0.01 m/s

Table 2: Descriptive statistics of the environmental data collected (T_g : Indoor globe temperature in °C, RH: Indoor relative humidity (%); N: Sample size; SD: Standard deviation)

		Chennai					Hyderabad					All					
			T _g	RH				T _g	RH				T _g	RH			
Season	Months	N	Mean	SD	Mean	SD	Months	N	Mean	SD	Mean	SD	N	Mean	SD	Mean	SD
Winter	1, 2	38	27.7	1.4	55.2	5.9	12to2	834	28.2	1.6	39.8	8.2	872	28.2	1.6	40.5	8.7
Summer	3 to 5	30	32.7	0.9	59.8	3.0	3 to 5	112	32.4	2.3	33.5	7.6	142	32.4	2.1	39.1	12.8
SWM	6 to 9	7	30.4	0.0	72.0	0.0	6 to 9	177	28.8	0.9	57.4	5.8	184	28.9	1.0	58.0	6.3
NEM	10 to 12	57	29.0	0.5	61.0	3.1	10, 11	97	28.5	1.0	56.0	10.0	154	28.7	0.9	57.9	8.5
All		132	29.5	2.1	59.7	5.5		1220	28.7	2.0	43.1	11.1	1352	29	2.0	45	11.7

Both Chennai and Hyderabad have four distinctly different seasons, as shown in Table 2. In Chennai, due to warm and humid weather throughout the year, and the AC usage was high and NV usage was low. As a result, we collected around 132 sets of data in NV mode in Chennai and the rest of the data from Hyderabad. Table 2 also describes the indoor environment in both the cities.

The first author conducted the surveys once every season, while in the other months trained local surveyors did the surveys. In all the surveys, the surveyors noted down the clothing and activity levels of the occupants against their respective thermal questionnaire responses.

We assessed thermal sensation (TS) using the American Society of Heating Refrigeration and Air-conditioning Engineers (ASHRAE)'s seven-point TS scale. We measured thermal acceptability again using ASHRAE's scale as binary input. In all the surveys we noted down the operation of environmental controls as binary data, such as: doors, windows, curtains/blinds, fans, lights, hand fans and evaporative coolers (0 = not in use/ closed; 1 = in use/ open). Outdoor air temperature and relative humidity for all the days of the survey were

obtained from the local meteorological stations. The buildings had sash or horizontal sliding wooden/ steel/ aluminium windows.

3 Results and Discussion

3.1 Outdoor and indoor temperature profiles and thermal sensation

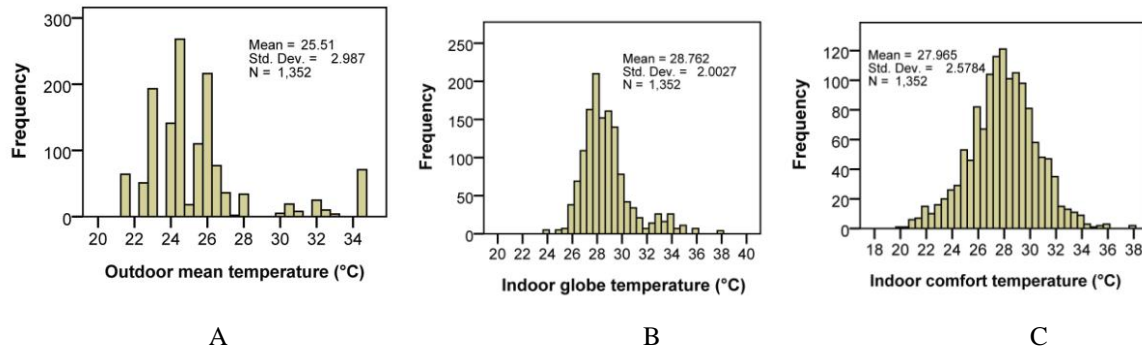

Figure 2. Distribution of outdoor mean temperature, indoor globe temperature and indoor comfort temperatures

The outdoor daily mean temperature (T_m) during the survey varied from 21.5 °C to 34.5 °C with 25.5 °C as the mean (Figure 2). The maximum temperature was experienced during the summer season (March through May). Chennai, being a coastal city, had high humidity throughout the year. Hyderabad is part of the Deccan Plateau and had a very dry summer and moderately humid winter. During the voting periods, the indoor globe temperature averaged at 28.8 °C, and ranged between 23.9 °C and 37.7 °C. Indoor and outdoor conditions in Chennai were slightly warmer than Hyderabad (but significant at 95% confidence interval (CI)). Seasonal variation in indoor and outdoor temperatures was evident.

The clothing and metabolism did not vary significantly throughout the survey. The mean clo value was found to be 0.70 clo (standard deviation (SD) = 0.08) and the mean metabolic rate was 1.01 Met (SD = 0.09 Met).

Mean thermal sensation was 0.4 (SD = 1.3). Interestingly, 35.9% subjects voted ‘neutral’ on the sensation scale. It is generally presumed that people voting on the central three categories of the sensation scale are comfortable (74.7 % in this study). As our survey involved hot and humid climates fewer subjects felt cold discomfort (5%), (i.e., voting -2 and -3) while 20.3 % had *warm* and *hot* sensations.

We estimated the comfort temperature (T_{comf}) by the Griffiths’ method using 0.5 as the Griffith’s coefficient (G) using the following relationship (Griffiths, 1990) for all the datasets:

$$T_{comf} = T_g + (0 - TS) / G \dots\dots\dots(1)$$

Figure 2 shows the distribution of the comfort temperature. Mean comfort temperature was found to be 28.0 °C.

The running mean of the outdoor mean temperature was estimated for all the data sets using the relationship,

$$T_{rm (tomorrow)} = (\alpha) T_{rm (yesterday)} + (1-\alpha) T_m (today) \dots\dots\dots(2)$$

Where, T_{rm} is the running mean temperature (°C), T_m is the outdoor daily mean temperature (°C), and α is a unit less constant between 0 and 1 and is usually taken as 0.8. It indicates a half-life of approximately 3.5 days (Humphreys, et al., 2013).

The occupant's thermal sensation varied with the indoor globe temperature. On regression, we noted a significant linear association:

$$TS = 0.26 T_g - 7.09 \dots\dots\dots (3)$$

(N = 1352, r = 0.40, standard error of the regression coefficient (S.E.) = 0.016, p<0.001)

3.2 The Adaptive model

An adaptive relationship was noted between the indoor globe temperature and monthly mean outdoor temperature (T_{m-m}) given by the following equation (4) (Figure 3, left). Each point is the aggregated data for all the floors in all the buildings with 'month' as the unit of analysis.

$$T_{comf} = 0.20 T_{m-m} + 22.8 \dots\dots\dots (4)$$

(Standard Error of slope = 0.038, r = 0.40, p < 0.001, N = 142 aggregated observations).

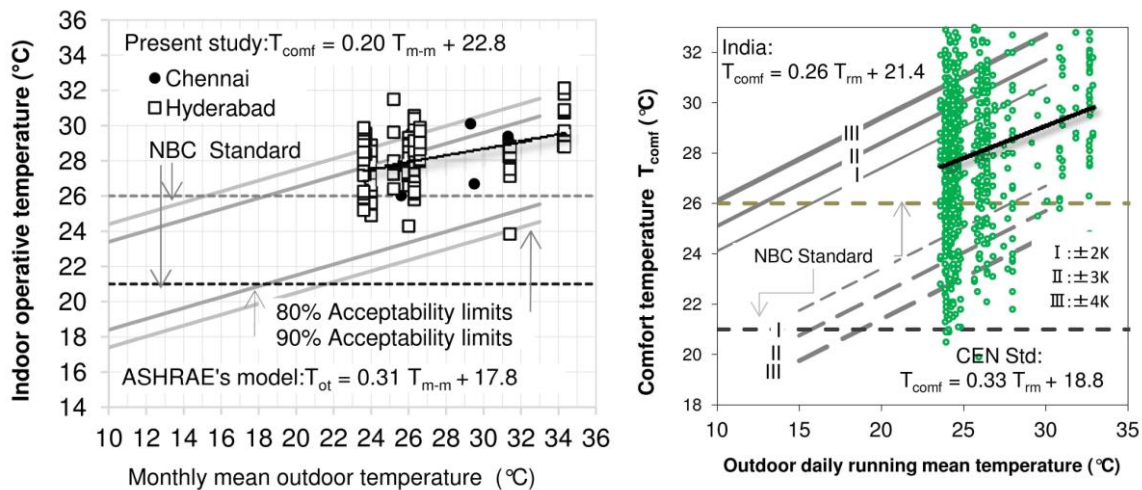

Figure 3. Adaptive model of thermal comfort (Left) Indoor comfort temperature varying with the monthly mean outdoor temperature, also shown are the NBC and ASHRAE standards; (right) Comfort temperature varying with the daily running mean temperature along with the CEN standard. (T_{ot} : Indoor operative temperature)

The gradient of our study is lower than the ASHRAE's adaptive model ($0.31 K^{-1}$) (Figure 3 left) (de Dear & Brager, 1998; ASHRAE, 2010). It can be observed that much of the data from the present study is around the upper applicability limit of the ASHRAE's model, as the cities surveyed are part of the hot and humid tropical climates.

The occupants' comfort temperature was found to be changing with the outdoor running mean temperature during the year-long survey. We noted a statistically significant linear relationship:

$$T_{comf} = 0.26 T_{rm} + 21.4 \dots\dots\dots (5)$$

(N = 1352, r = 0.24, S.E. = 0.028, p<0.001).

The adaptive relationship in the European standards (CEN:15251, 2007), mentions a slope of $0.33 K^{-1}$. It appears that the comfort temperature in Indian offices moved up slowly for unit increase in T_{rm} and T_{m-m} , than that of European offices (Figure 3, right) and the offices of the ASHRAE database (Figure 3, left) respectively.

Figure 3 also shows the comfort temperature limits (21-26 °C) suggested by the Indian National Building Code (NBC) (BIS, 2005). Most of the present data clearly lies above the upper comfort temperature limit of the NBC. It might be pertinent to review this standard.

3.3 Understanding the window opening behaviour

From the above adaptive relationship, we can observe that comfort temperature changes with the changing outdoor temperature. It means that people adapt in various ways to the changing thermal regime. Opening or closing windows is one such important action.

Table 3: Indoor air temperature and the proportion of the open windows in all the offices (N: sample size; SD: standard deviation)

Building	Indoor air temperature (°C)			Window			Door		
	N	Mean	SD	N	Mean	SD	N	Mean	SD
C1	21	30.8	0.7	21	0.00	0.0	21	0.24	0.4
C11	97	29.6	2.5	97	0.63	0.5	97	0.66	0.5
C13	8	29.5	0.9	8	0.75	0.5	8	0.75	0.5
C8	6	28.9	0.0	6	1.00	0.0	6	0.00	0.0
H1	286	28.5	1.1	281	0.18	0.4	91	0.34	0.5
H10	32	30.4	2.5	32	0.91	0.3	32	1.00	0.0
H12	131	27.2	0.6	124	0.98	0.1	131	0.95	0.2
H13	18	27.6	0.7	5	0.80	0.4	18	1.00	0.0
H2	106	30.9	2.3	81	0.40	0.5	106	1.00	0.0
H3	262	28.8	1.2	255	0.02	0.1	261	0.84	0.4
H4	33	29.8	2.8				33	0.42	0.5
H5	20	28.2	1.3	20	0.20	0.4	20	0.30	0.5
H8	28	29.4	3.0	28	0.89	0.3	28	1.00	0.0
H9	304	29.6	1.9	304	0.46	0.5	55	1.00	0.0
All	1352	29.1	1.9	1262	0.38	0.5	907	0.78	0.4

Table 2 lists the mean indoor air temperature and the mean window and door opening for all the offices. From this table we can note that, in 38% of the total observations, windows were found to be open (mean window opening = 0.38. N = 1262). This is very close to the mean window opening of 0.33, observed in Pakistan office and commercial buildings (Rijal, et al., 2008a). On the contrary, in UK offices the mean window opening was found to be 0.70 in NV mode (Rijal, et al., 2007).

A closer look at Table 2 reveals that the mean value of window opening in various offices varied from 0.0 to 1.00. During the field survey, we observed many non-thermal reasons for generally lower frequency of window-opening in Indian offices. These reasons will be described later. It indicates that in some of offices, the windows were never opened and in some, were never closed during the survey period. Field study observation further pointed that, in these offices the window opening was either very low (less than 20%, windows were never opened due to broken shutter handles, hinges, stoppers etc.) or very high (more than 90%, windows could be seldom closed fully, due to broken glass panes, sashes etc.). Moreover, in some offices we could not collect much data in the yearlong survey.

Therefore for further analysis, we used only the data from the offices where the window operation was not perhaps limited by such factors. These translated into the following objective criteria for selection of data for the analysis of window opening: an office where the

proportion of open windows is more than 20% and less than 90% and where we have more than 30 sets of data. This selection yielded 507 sets of data (values in bold in Table 3).

Seasonal and diurnal variation in window opening

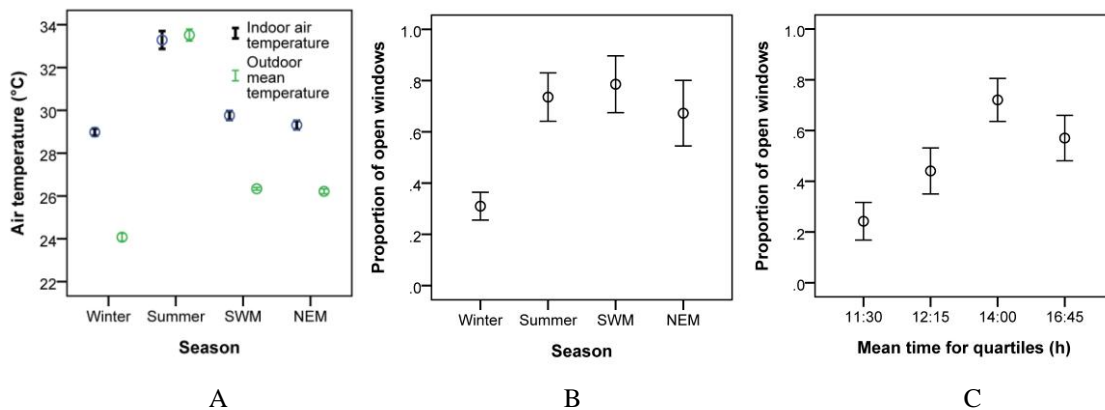

Figure 4. Seasonal variation in (A) indoor air temperature and outdoor daily mean temperature, (B) Proportion of open windows, (C) Proportion of open windows at various time intervals of the day (at 95% CI) (N = 507).

Figure 4 (A, B) shows the seasonal differences in the indoor and outdoor temperature and the window opening behaviour. Window opening was significantly lower in winter as additional air movement through an open window might have perhaps led to cold drafts. In the other three seasons the proportion of open windows remained similar without significant differences. However, we noted windows being closed during very hot periods in summer in Hyderabad, to avoid hot breezes coming in. Similar phenomenon was noted in some of the Pakistani offices in hot-dry areas of Quetta (Rijal, et al., 2008). A majority of windows were opened during the summer and monsoons.

Window opening also varied during the day. For example, window opening increased as the day progressed, peaking during the mid-day, and gradually receding by evening (Figure 4: C). Similar seasonal and diurnal variation in window operation was observed by other researchers in both office and residential buildings (Rijal, et al., 2013).

3.3 Potential of the open window in modifying the indoor climate

Air temperature: an important stimulus

Table 4: Correlation matrix of proportion of open window (P_w), indoor air temperature (T_a) outdoor daily mean temperature (T_m) and indoor globe temperature (T_g) (N = 507, $p < 0.01$)

	T_a (°C)	T_m (°C)	T_g (°C)
P_w	0.38	0.32	0.36
T_a		0.79	0.79

Table 4 presents the correlation matrix between various thermal variables and the window opening behaviour. Indoor air temperature is noted to be one of the important variables that influenced the window opening, as noted by many other researchers (Brager, et al., 2004; Rijal, et al., 2008; Inkarojit & Paliaga, 2004) We also noted monthly variation in indoor and outdoor temperatures and consequent changes in window opening behaviour, as shown in Figure 5 (A, B).

The proportion of open windows remained low in the winter months (Jan and Feb) and was near 1.0 in the summer month of April. During the peak summer month of May, window opening was slightly lower. This perhaps is in response to the very-hot and dry summer

weather in Hyderabad. Although this difference is not statistically significant, a trend is noticeable.

The proportion of open windows gradually increased as the indoor temperature went up. Figure 5 (C) shows the proportion of open windows at pentiles (ranked and aggregated groups of data) of indoor temperature. When the indoor temperature was around 29.5 °C, over 60% windows were found to be open, and at 27.5 °C about 20%.

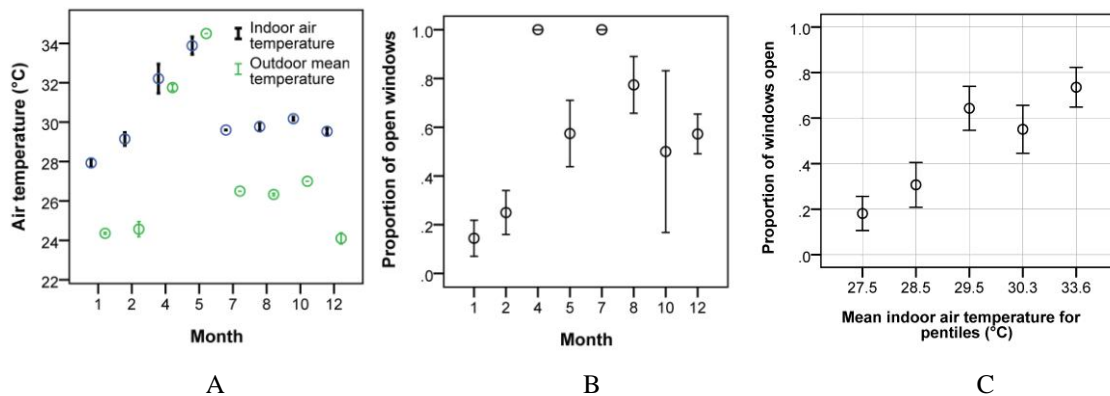

Figure 5. Monthly variation in (A) indoor air temperature and outdoor daily mean temperature, (B) Proportion of open windows, (C) Proportion of open windows at pentiles of indoor air temperature (at 95% confidence interval).

This is much lower than that of 50% open windows at 27 °C of indoor temperature observed in Pakistan buildings and 75% in UK buildings (Rijal, et al., 2008a; Rijal, et al., 2007). In a residential building study done in summer and monsoon in Hyderabad, about 40% of the windows were open at the same temperature (Indraganti, 2010). Researchers noted subjects in residential environments operating openings more freely than in offices ((Rijal, et al., 2013).

Generally warmer conditions prevail in South India when compared to Pakistan and UK. For example, 27 °C coincided with the winter indoor temperatures in NV buildings. It is possible that acclimatisation of the subjects to local warm climate could have led to lower window opening in India at this temperature range. Some of the other reasons could be various obstacles that occupants faced in being able to operate the windows, as explained in the subsequent sections.

Effect of open window on comfort temperature

The use of windows had an effect on the temperatures people found to be comfortable, revealing that people were comfortable at warmer temperatures with open windows, either due to the higher levels of air movement (discussed later), or simply the connection with the outdoor climate. The effect is more evident in Chennai, which has a warm-humid coastal climate. For example, the globe temperature when the subjects voted neutral on the sensation scale rose from 27.7 °C when the windows were closed to 29.6 °C by opening the windows (Figure 6A). The difference is statistically significant at 95% confidence interval.

A change in comfort temperature was also noted when the windows were opened in Chennai (Figure 6B). For instance, the mean comfort temperature when the windows were open was 29.3°C which is 1.7 K higher than when the windows were closed. Therefore, opening windows increased the comfort temperature significantly ($p < 0.05$). We find this an improvement, because comfort at higher temperature is achieved by opening the windows and without the AC usage. However, in Hyderabad, the difference was not statistically significant. Although not significant, opening the doors in addition also has changed the comfort temperature (Figure 6 C). In Pakistan offices, they noted 1.1 K rise in the comfortable indoor globe temperature through cross-ventilation (Rijal, et al., 2008a).

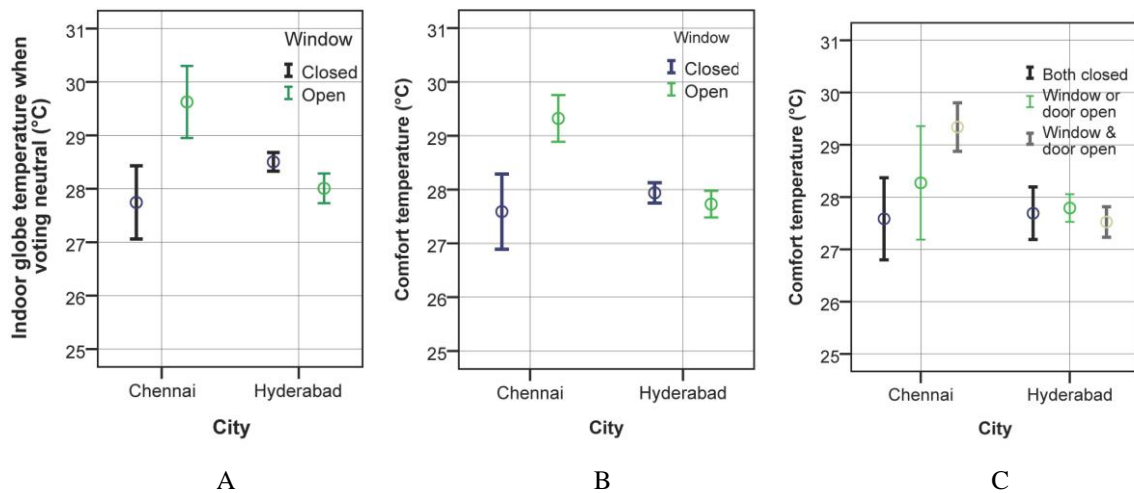

Figure 6. Effect of cross ventilation on comfort temperature in Chennai and Hyderabad, Effect of open windows on (Left) indoor globe temperature when voting 'neutral' on the sensation scale, (center) indoor comfort temperature; Effect of the combined effect of doors and windows on comfort temperature

Combined effect of cross ventilation and fans

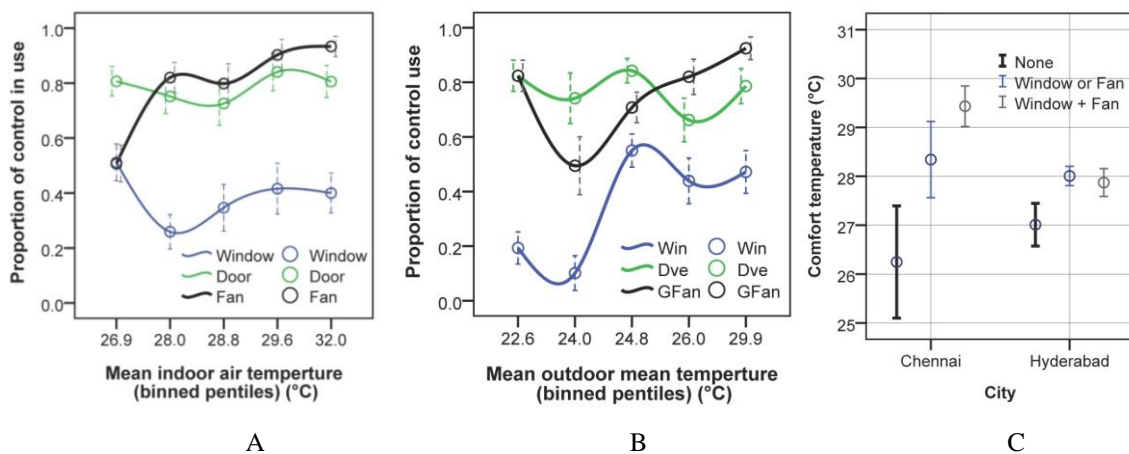

Figure 7. Changing use of various environmental controls with (A) indoor air temperature and (B) outdoor daily mean temperature; (C) Effect of these controls (window and fan) on T_{comf} at 95% CI.

Most of the surveyed areas in NV mode also had operable doors, which opened into the outdoors or semi-outdoors, naturally ventilated covered public corridors or other such areas. We have noted these doors also being used adaptively, as the temperature changed. Indoor air temperature and proportion of open doors displayed low but significant correlation ($r = 0.1$, $p < 0.01$). Similar to the window operation, the door operation was also found to be influenced by many non-thermal and some cultural factors. These could perhaps have led to very high proportion of doors being open in Indian offices. On the contrary, the proportion of open doors was more variable (20- 100%) in Pakistan surveys, indicating much better adaptation (Rijal, et al., 2008a).

The occupants used ceiling fans along with the operable openings in office buildings in India. Figure 7 shows the proportion of windows, doors and fans in use in various pentiles of indoor air temperature and outdoor daily mean temperatures. Window and fan usage increased with temperature, much more than the doors. Figure 7(C) shows the combined effect of window and fan usage.

The comfort temperature in Chennai was 26.3 °C when the windows were closed and fans were ‘off’, and was 29.4 °C when both these controls were in use. It means that use of simple controls like windows and fans raised the comfort temperature by 3.1 K. Although statistically significant, the combined effect of fan and window was not so high in Hyderabad. It resulted in a marginal increase in comfort temperature, of about 0.8 K (a change from 27.1 °C to 27.9 °C). This can perhaps also be attributed to non-availability and/or low quality of fans in some Hyderabad offices (Indraganti, et al., 2013).

Influence on indoor air movement

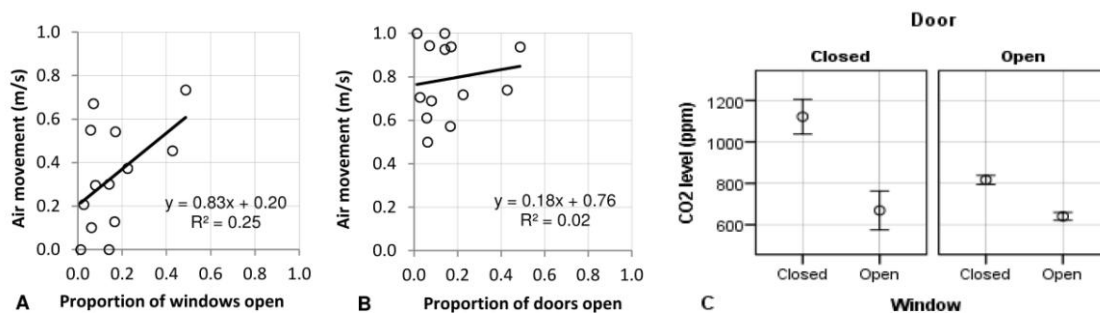

Figure 8. Indoor air movement increasing with the increase in (left); ‘open windows’ and (right) ‘open doors.’ Each point represents the binned data for each month of the survey (N = 1352).

Increasing the use of windows played a major role in improving the indoor air movement and thus indoor comfort in Indian offices. Figure 8 (A, B) shows the relationship between the use of windows and doors and the indoor air movement. The occupants seem to have successfully achieved higher air speeds by operating the windows, and thereby attained comfort at high indoor air temperatures on the order of 28.7 °C (mean) (Figure 2 B). A similar observation was made by other investigators as well (Brager, et al., 2004; Robinson & Haldis, 2008).

The relationship between indoor air movement and the proportion of open doors does not seem to be as strong as it is with the proportion of open windows. This may partially be attributed to the high proportion of ‘doors open’ observed during the survey. On the contrary, in Pakistan buildings, the use of open doors appears to have contributed more robustly towards the increase of indoor air speed (Rijal, et al., 2008a).

Opening windows lowered the carbon dioxide concentration (CO₂) significantly, reducing it by an average of 200 ppm. Cross ventilation (opening both doors and windows) reduced CO₂ substantially. The mean CO₂ concentration when both doors and windows were open was 482 ppm lower than when they were closed. This reinforces the health benefits underlying the natural ventilation as noted by many in the literature (Brager, et al., 2004).

3.4 Logistic regression analysis to predict the use of windows

A stochastic relationship better explains the relationship between window-opening behaviour and the indoor temperature (Nicol, 2001). For example, the probability of opening a window (P_w) against an external stimulus such as indoor air temperature (T_a) can be evaluated. Therefore, we used logistic regression, following the methods used by others (Haldis & Robinson, 2008; Rijal, et al., 2008a; Rijal, et al., 2013; Indraganti, et al., 2014; Yun & Steemers, 2008).

The logit is given by the equation:

$$\text{Logit}(p) = \log(p/(1-p)) = bT+c \dots\dots\dots(6)$$

Where,

$$p = e^{(bT+c)} / (1 + e^{(bT+c)}) \dots\dots\dots(7)$$

Where p is the probability that the window is open, T is the temperature (in this case indoor air temperature), b is the regression coefficient for T and c is the constant in the regression equation.

The logistic regression of P_w and T_g yielded the following equation with the standard error of slope (SE) and Negelkerke R^2 values:

$$\text{logit}(p) = 0.395 T_a - 11.85 \dots\dots\dots(8)$$

($N = 507$; $R^2 = 0.189$; $SE = 0.052$)

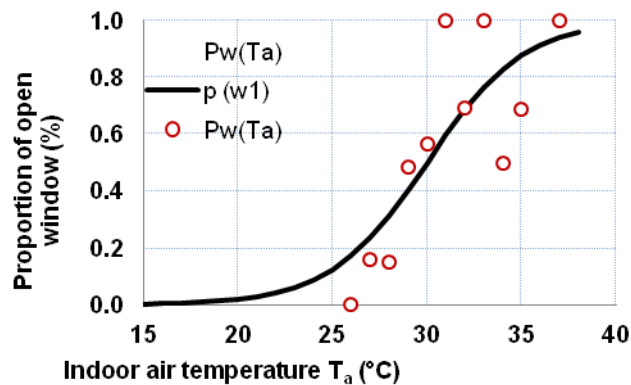

Figure 9. Logistic regression of window usage with indoor air temperature

This equation is shown in Figure 9, with binned data from the field study superimposed on it. The actual data follows the regression line closely. Using this equation we can estimate that at an indoor air temperature of 30 °C, 50 % of the windows would be opened.

We noted comparable findings from other reports. Pakistan survey reported a slope of 0.176 (with Cox and Snell R^2 of 0.19) for the logistic regression of indoor globe temperature and window usage. Their equation also predicted 50% window usage at 30 °C of globe temperature (Rijal, et al., 2008a). The UK studies recorded a regression coefficient of 0.354 when window opening was regressed with indoor globe temperature (Rijal, et al., 2007).

4 Obstacles in operating the openings

The survey included office buildings owned and managed by: central and state governments, large corporate houses, large and small companies, and medium and small consultancy firms. All the buildings that functioned in NV mode had operable openings (windows and or doors) with varying degrees of upkeep and operation, as we observed during the survey. The following analysis is based on these observations and anecdotal responses the authors and the surveyors received first-hand from the occupants, managers and owners during the 14 month long field investigation.

The obstacles observed in the adaptive operation of windows are categorised broadly into the following five aspects:

- Design and construction
- Operation and maintenance (O& M) and environmental
- Socio-cultural
- Attitudinal
- Behavioural

4.1 Design and construction aspects

In both cities, it is mandatory to seek building approvals from the statutory authorities prior to construction. From field observations and anecdotal responses from the building managers/owners we understood that, most of the offices might not have been constructed fully adhering to the approved designs. This peculiarity in the Indian office buildings is observed to have also possibly hindered the adaptive operation of openings. We attempt to mention a few such examples that impeded the adaptive operation of windows.

Curtain glazing as a cosmetic treatment



Figure 10. Windows inside made inoperable and ineffective by curtain glazing and bird breeding. (A, B) Interior and exterior views of the cosmetic curtain glazing layer and (C) Avian breeding and debris collection between the exterior curtain-glazing (C1) and the operable window (C2);. (B1) Balcony spaces being merged with the office interior space often in violation of the local by-laws, making window operation less than promising

Many of the office buildings had fixed curtain glazing on the front facades. In most cases, the curtain glazing is attached to the front façade as a cosmetic treatment. It is fitted on the wall in front of the operable windows, leaving 0.15 m – 0.23 m clearance in between, and essentially making the windows defunct. It is important to note that the plenum of the double skin façade is not connected to a mechanical ventilation system. Often times, the plenum remained a closed unventilated dead space.

Trash was often found dumped in the gap between the curtain glazing and windows. This perhaps has invited murine and avian families to flourish in the gaps (Figure 10). This has challenged the adaptive window operation even more.

Fixed furniture in the absence of interior design norms

We observed in some of the offices that interior fitments like tables were sometimes fixed against the windows blocking their operation permanently (Indraganti, et al., 2014). This practice is prevalent perhaps because there are no norms in India that govern the interior design of spaces.

Narrow set-backs missing overhangs and balconies, and direct solar radiation

Deep overhangs and balconies often belt the exterior walls in public buildings in India. These shade the walls and windows, thus enabling better window and door operation. These semi-open balconies are shown usually in the approved designs. However, in many cases during construction, these were enclosed and added to the adjoining office space. This in our opinion could have happened perhaps for two reasons: (1) poorly enforced building regulations, and (2) increased demand for office space, sometimes at a later date (Figures 10:B, 11:A, B).

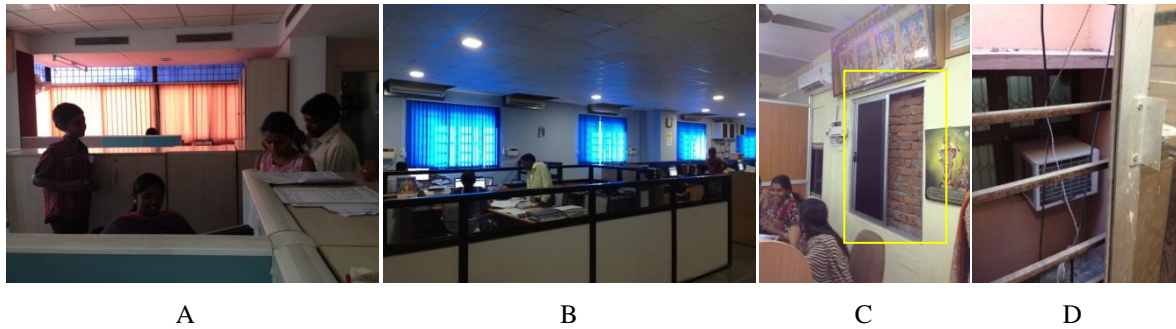

Figure 11. (A, B) Interior views of offices showing annexed balcony spaces with intense glare; (C) New annexe built against an operable window; (D) Narrow set-backs and with window AC units on either side often deter adaptive window operation due to hot air plume

As a result, the windows were shifted to the building boundary, no longer benefiting from the overhangs or deep shading devices. In our field study, we noted such windows not being used well, possibly for admitting a lot of direct solar radiation, more so when they were on the western and south-western facades (Figure 11A, B). Inkarojit and Paliaga also observed window operation varying with façade orientation even in milder climates like Berkeley, similar to others (Inkarojit & Paliaga, 2004; Zhang & Barrett, 2012).

In an earlier study in Hyderabad, balcony doors were found to be in greater use in summer than windows because opening the windows with smaller shading devices permitted direct solar radiation into the interior (Indraganti, 2010).

In this study we noted in a few cases new extensions to office spaces enclosing the semi-open/ balcony spaces, against the operable windows. These often blocked the windows completely (Figure 11: C).

Sometimes, due to very narrow set-backs, the clearance between the outdoor units of window AC units of two adjacent buildings was found to be too small. This arrangement did not physically obstruct the window operation. However, opening the windows in some of the buildings surveyed was not useful due to hot air plume emanating from the neighbouring window AC unit. Sometimes, when the power cuts were staggered in adjacent buildings, this close proximity of window AC units also proved a major deterrent to window operation in buildings we studied (Figure 11 D).

4.2 Operation and maintenance (O&M) and environmental aspects

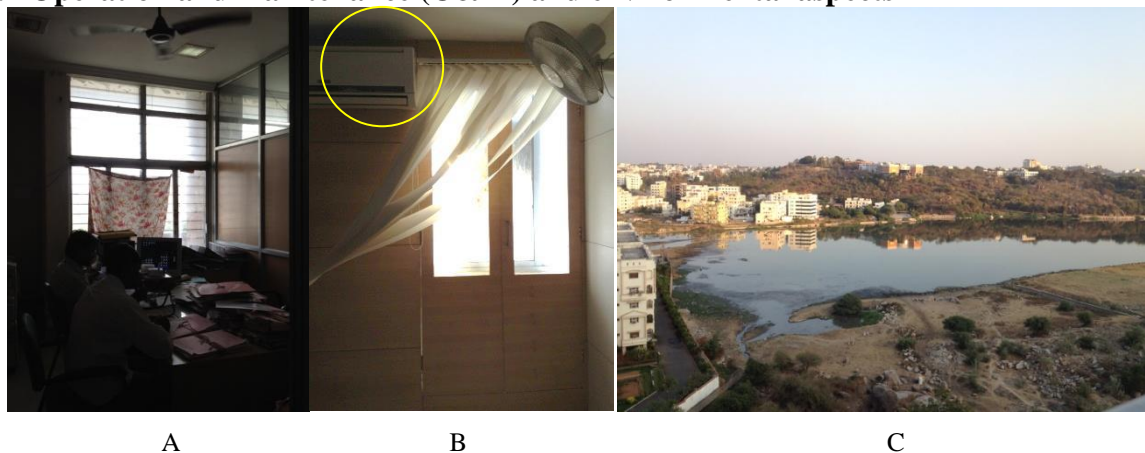

Figure 12. (A) Jammed and rusted steel windows in a government office and the occupants using fabric to avoid glare and reduce drafts through the broken sash; (B) Wall panelling and blinds camouflaging and making the window behind inoperable, thus encouraging AC use shown circled; (C) Polluted obnoxious water-bodies promoting mosquito breeding thus prohibiting window operation (office surveyed is in the front).

We noted some subjects in a few buildings facing difficulties in operating the windows possibly due to O&M issues. The windows in a few government and small offices were broken or were jammed, or had stoppers missing (Figure 12A). Some of the windows were found locked throughout the survey. In some cases, proximity to ill-maintained toilets and service chutes discouraged the occupants from opening these windows.

In some rented offices, the office owners camouflaged the ill-maintained windows with cosmetic wall panelling and blinds (Figure 12 B), thus closing them completely. In other areas surveyed, severe air pollution and mosquitoes further challenged the occupants and managers from opening the windows throughout the year (Figure 12C).

4.3 Socio-cultural aspects

Anecdotal responses to open-ended enquires linked the window/ door operation to many socio-cultural aspects. These often impeded the window operation. Doors in most of the naturally ventilated offices remained open perhaps due to a cultural practice, rather than in response to thermal stimuli. This observation also partially explains the high percentage of doors found open during the study (Figure 13 A, B).

Vandalism

In some of the neighbourhoods, the building managers preferred to keep the windows shut. This was presumably to avoid stone-pelting from the surrounding residents. These residents of low-income colonies allegedly feared privacy invasion owing to the open office windows. Often times, such permanently closed windows were found filled with trash behind the blinds (Figure 13 C).

Responsibility of operating the openings

In some of the offices, we noted attendants operating the windows, doors and fans routinely during the day. However, we also observed some of the occupants often ushering them to operate the windows, doors and fans when in thermal discomfort. Thus, the window operation in Indian offices perhaps was also resting on the efficacy of the attendant's service (Figure 13 D).



Figure 13. (A, B): Opening doors is more a cultural practice, than in response to thermal stimuli; (C): Vandalism hindering window operation; (D): Office attendants often operate the openings and the pantry.

4.4 Attitudinal impediments

The participants of our survey belonged to the middle management in the organisational hierarchy. Most of them were salaried workers. Through open-ended questions, we noted that some subjects displayed a nonchalant lethargic attitude and the operation of controls might have had little bearing in their minds.

We understood that the occupants might not have perceived the full potential of an environmental control in their immediate thermal environment. Possibly as a consequence, it could have led to the lower percentage of open windows noted during the study (38%) (Table 3), as compared to the figure reported from UK offices (70%) in NV mode (Rijal, et al., 2007). However, it is important to note that the climate and types of building controls are different in both the cases.

Thermal acceptance in the survey was measured through a direct question, ‘do you accept the present indoor environment?’ (ASHRAE, 2010). The subject’s response was noted as a binary input, 0: acceptable and 1 : unacceptable. We observed a low thermal acceptance of about 40% among the subjects (Indraganti, et al., 2014). On the other hand, a residential building study conducted in Hyderabad during summer found 86% subjects accepting the environment on the same scale.

On juxtaposing the subjects’ low thermal acceptance with their anecdotal responses, we noted a missing sense of ownership about their immediate thermal environment among the some of the subjects. This attitudinal lethargy could also have limited the adaptive control operation in a few offices and, thus had an effect on their thermal acceptance (although the casual relationship between the two cannot be stated with certainty).

This is in contrast to (1) the behaviour of owner-subjects in residential environments, who have taken many extra measures for better use of windows (Indraganti, 2010) and, (2) the occupants of residential environments who operated controls better and expressed higher satisfaction (Rijal, et al., 2013).

On the contrary, we can also note instances of low user involvement in operation of controls even in high quality sustainable green buildings. Brager and Pigman studied how the occupants used and viewed their windows through a field study in a sustainable green building in USA (Brager & Pigman, 2013). Although the windows in this building were rated extremely highly in terms of accessibility, usability, and responsiveness, they noted only 6% of the window users adjusting the windows on a daily basis, 38% weekly and 41% monthly basis.

4.5 Behavioural aspects



Figure 14. A motivational campaign to save power in a Chennai office as a result of acute power shortages

Successful operation of passive environments necessitates active participants (Fergus, et al., 2012). Customarily in most offices we studied, the occupants/ office attendants setup the windows on arrival and closed them prior to their departure, on normal occasions. As a result, we could not observe many occupants engaged in active window operation throughout the

day. Windows once opened remained such through the day (Figure 4:C). Yun and Steemers observed similar time-dependent occupant behaviour in UK offices (Yun & Steemers, 2008).

Occupants' and attendant's lack of understanding of effectiveness of environmental controls in a few offices often impeded their efficient operation. Some managers were seen motivating the occupants on the appropriate use of controls. Figure 14 shows one such motivational campaign as observed in an office in Chennai. Ackerly and Brager pointed that window signalling systems employed in offices in US had impacted the control operation the most when the rationale behind their use was well understood and that they were visible (Ackerly & Brager, 2013). They stress the need for communicating with the occupants to enhance their participation.

5 Concluding remarks

This paper describes the occupant responses and simultaneous thermal measurements collected in a field study done in two cities of Chennai and Hyderabad, with a focus on occupant use of openings.

Chennai offices were slightly but significantly warmer, more humid and airier than those of Hyderabad. Indoor conditions evidently moved in harmony with outdoors. For a unit change in outdoor monthly mean temperature, the indoor globe temperature varied by about half a degree Kelvin. The mean comfort temperature on all data was found to be 28 °C.

Occupants used the openings adaptively as the temperatures changed. Open windows and doors increased the indoor air movement, influenced comfort temperature and lowered CO₂ levels. Use of doors was found to be higher than that of windows. In about 38% cases of all data we noted the windows open, while the same figure for doors was 80%. We developed logistic regression for window usage. Using this, we predicted about 50% open windows at 30 °C of indoor air temperature.

We noted many hindrances to the adaptive use of windows and doors. These were non thermal factors relating to the design and construction, operation and maintenance and socio-cultural and behavioural attitudes. Effective handling of these at various levels of building design, construction, operation and maintenance of the facility would be advantageous in improving the occupant operation of controls.

Acknowledgements

The Japan Society for Promotion of Science and The University of Tokyo, Japan funded this research. For data analysis, we used the facilities at the Centre for the Built Environment, University of California Berkeley, made available through the Fulbright Grant. They all are thanked for their financial and logistic support. We thank Mukta Ramola and Prakash K for their commitment to the field surveys. We acknowledge the support of all the heads of the offices and the subjects for their involvement.

References

- Abbaszadeh, S., Zagreus, L., Lehrer, D. & Huizenga, C., 2006. *Occupant Satisfaction with Indoor Environmental Quality in Green Buildings*. Lisbon, s.n., pp. Vol. III, 365-370.
- Ackerly, K. & Brager, G., 2013. Window signalling systems: control strategies and occupant behaviour. *Building Research & Information*, 41(3), pp. 342-360.
- ASHRAE, 2010. *ANSI/ASHRAE Standard 55-2010, Thermal environmental conditions for human occupancy*, Atlanta: s.n.
- Baker, N. & Standeven, M., 1996. Thermal comfort for free-running buildings. *Energy and Buildings*, pp. 23 (1996) 175-182.

- BIS, 2005. *National Building Code 2005*. s.l.:Bureau of Indian Standards.
- Brager, G., 2006. Mixed Mode Cooling. *ASHRAE Journal*, 48(30-37).
- Brager, G. & Pigman, M., 2013. *Adaptive Comfort in Mixed-Mode Buildings: Research Support Facility, National Renewable*, s.l.: Center for the Built Environment, UC Berkeley.
- Brager, G. S., Paliaga, G. & de Dear, R., 2004. Operable Windows, Personal Control. *ASHRAE transaction*, pp. Vol.110, Part 2, pp 17-35.
- CEN:15251, 2007. *Indoor environmental input parameters for design and assessment of energy performance of buildings: addressing indoor air quality, thermal environment, lighting and acoustics..* Brussels: Commite European de Normalisation.
- de Dear, R. J. & Brager, G. S., 1998. Developing an Adaptive Model of Thermal Comfort and Preference. *ASHRAE Transactions*, 104(1), p. 145–167 .
- Griffiths, I. D., 1990. *Thermal Comfort in Buildings with Passive Solar Features: Field Studies* , s.l.: s.n.
- Haldi, F. & Robinson, D., 2008. On the behaviour and adaptation of office occupants. *Building and Environment*, Volume 43, pp. 2163-2177.
- Humphreys, M., Rijal, H. & Nicol, J., 2013. Updating the adaptive relation between climate and comfort indoors; new insights and an extended database. *Building and Environment* , Volume 63, pp. 40-45.
- Indraganti, M., 2010. Adaptive use of natural ventilation for thermal comfort in Indian apartments. *Building and Environment*, 45(12), pp. 1490-1507.
- Indraganti, M., Ooka, R. & Rijal, H. B., 2013. Field investigation of comfort temperature in Indian office buildings: a case of Chennai and Hyderabad. *Building and Environment*, 65(7), pp. 195-214.
- Indraganti, M., Ooka, R., Rijal, H. B. & Brager, G. S., 2014. Adaptive model of thermal comfort for offices in hot and humid climates of India. *Building and Environment*, April, 74(4), pp. 39-53.
- Inkarojit, V. & Paliaga, G., 2004. *Indoor climatic influences on teh operation of windows in a naturally vintilated building*. Eindhoven, Plea2004 - The 21st Conference on Passive and Low Energy Architecture. Eindhoven, The Netherlands, 19 - 22 September 2004.
- Leaman, A. J. & Bordass, W. T., 1997. *Productivity in Buildings: the "killer" variables*. London, s.n.
- Nicol, F., Humphreys, M. & Roaf, S., 2012. *Adaptive thermal comfort principles and Practice*. London: Routledge.
- Nicol, F. J., 2001. *Characterising occupant behaviour in buildings: towards a stochastic model of occupant use of windows, lights, blinds, heaters and fans*. Rio, Brazil, Proceedings of the seventh international IBPSA conference.
- Rijal, H. B., Honjo, M., Kobayashi, R. & Nakaya, T., 2013. Investigation of comfort temperature, adaptive model and the window-opening behaviour in Japanese houses. *Architectural Science Review*, 56(1), pp. 54-69.
- Rijal, H. B. et al., 2008. Development of adaptive algorithms for the operation of windows, fans, and doors to predict thermal comfort and energy use in Pakistani buildings. *ASHRAE Transactions*, SL-08(056), pp. 555-573.

- Rijal, H. B. et al., 2007. Using results from field surveys to predict the effect of open windows on thermal comfort and energy use in buildings. *Energy and Buildings*, p. 39 (2007) 823–836 .
- Rijal, H. B. et al., 2008a. Development of an adaptive window opening algorithm to predict the thermal comfort, energy use and overheating in buildings. *Journal of Building Performance Simulation*, pp. Vol 1, No1, March 2008, 17-30.
- Robinson, D. & Haldi, F., 2008. An integrated adaptive model for overheating risk prediction. *Journal of Building Performance Simulation*, Volume 1, pp. 43-55.
- Sharma, M. R. & Ali, S., 1986. Tropical Summer Index—a study of thermal comfort in Indian subjects. *Building and Environment*, 21(1), p. 11–24.
- Yun, G. Y. & Steemers, K., 2008. Time-dependent occupant behaviour models of window control in summer. *Building and Environment*, 43(9), pp. 1471- 1482.
- Zhang, Y. & Barrett, P., 2012. Factors influencing the occupants' window opening behaviour in a naturally ventilated office building. *Building and Environment*, Volume 50, pp. 125 - 134.

Summertime Thermal Comfort in Australian School Classrooms

Richard de Dear, Jungsoo Kim, Christhina Candido, Max Deuble

The University of Sydney, Faculty of Architecture, Design and Planning, Sydney, Australia

Abstract

Considering school students spend up to one third of their day inside classrooms, it's surprising how few detailed empirical studies have been conducted into how the thermal environment of classrooms affects students' comfort and performance. Whereas PMV tends to exaggerate warm discomfort for adults, the literature suggests it *underestimate* children's actual thermal sensation, but there is no coherent explanation for this in terms of metabolic or other physiological differences to date. The aim of this study was to conduct a thermal comfort survey in actual classrooms with a view to empirically defining preferred temperatures, neutral temperatures, and acceptable temperature ranges for Australian school children, and to compare them with findings from adult populations. The study informs a thermal comfort (air conditioning) policy being developed for Australian schools.

The survey was conducted in a mixture of Air-Conditioned (AC), Evaporative-Cooled (EC), and Naturally-Ventilated (NV) classrooms in 10 schools during the Austral summer of 2013. Both Primary (grade) school and high schools were included in the sample. The survey was conducted twice a day (morning and afternoon), and the survey period varied between schools, from one week up to three weeks. After quality assurance processing a total of 3,129 questionnaires were retained from the sample of students and 138 samples were from the teachers.

An indoor operative temperature of about 22.5°C was found to be the students' neutral and preferred temperature, which is generally cooler than expected of adults under the same thermal environmental conditions, confirming earlier research findings in the thermal comfort literature. Working on the industry-accepted assumption that an acceptable range of indoor operative temperatures corresponds to mean thermal sensations of -0.5 through +0.5 (ASHRAE 2013; ISO 2005), the present analysis indicates an acceptable summertime range for primary and high school students from about 18.5 through to about 26.5°C operative temperature.

The paper concludes with hypotheses to explain differences between thermal comfort of children and adults.

Keywords

Thermal comfort, field study, school children, questionnaire, PMV, adaptive model

1 Introduction

It is commonly believed that warm indoor temperatures and the ensuing thermal discomfort result in decreased productivity/performance and mental acuity, and this generalizes to the educational arena, resulting in considerable public pressure being placed upon school

administrations to provide indoor climates that optimise students' educational achievements (Mendell & Heath 2005; Wargocki & Wyon 2007; Bako-Biro et al. 2012). The flip-side of the coin is a collective responsibility to minimise the environmental impacts resulting from those classroom indoor climates. Their operational energy consumption and associated greenhouse gas emissions need to be minimised and justified, so here again there is clear requirement to identify exactly what indoor climatic conditions are actually required by school children. This paper describes a project in which classic thermal comfort field methods are applied to the question of thermal comfort of school children in Australia.

Table 1 Summary of previous thermal comfort field studies conducted in school classrooms

Study	Location	Climate	Season	Ventilation Type	Age Group	Sample Size	Neutral Temperature
Auliciems (1969)	England	Temperate	Winter	NV	11-16	624	16.5°C
Pepler (1972)	Oregon	Temperate	Spring and Autumn	NV and AC	7-17	NV: 100 AC: 66	NV: 21.5 to 25°C AC: 22 to 23°C
Auliciems (1973)	England	Temperate	Summer	NV	11-16	624	19.1°C
Auliciems (1975)	Australia	Sub-tropical	Winter	NV	8-12 and 12-17	Not given	Primary: 24.2°C Secondary: 24.5°C
Kwok (1998)	Hawaii	Tropical	Winter and Summer	NV and AC	13-19	NV: 2,181 AC: 1,363	NV: 26.8°C AC: 27.4°C
Kwok and Chun (2003)	Japan	Sub-tropical	Summer	NV and AC	13-17	74	Not calculated
Wong and Khoo (2003)	Singapore	Tropical	Summer	NV	13-17	493	28.8°C
Corgnati et al., (2007)	Italy	Mediterranean	Winter	NV	12-17	440	Not calculated
Hwang et al., (2009)	Taiwan	Sub-tropical	Autumn	NV	11-17	944	23 to 24°C
Zeiler and Boxem (2009)	Netherlands	Temperate	Winter	AC	Primary school	174	Not calculated
ter Mors et al., (2011)	Netherlands	Temperate	Winter, Spring and Summer	NV	3-11	79	Not calculated
De Giuli et al., (2012)	Italy	Mediterranean	Spring	NV	9-11	614	Not calculated
Liang et al., (2012)	Taiwan	Sub-tropical	Autumn	NV	12-17	1,614	22.4 to 29.2°C
Teli et al., (2012)	England	Temperate	Spring	NV	7-11	230	20.5°C

Note: Ventilation types include naturally-ventilated (NV) and air-conditioned (AC) classrooms.

Table 1 provides a summary of thermal comfort studies conducted over the past 40 years in school/classroom environments. Notwithstanding the geographic, climatic and demographic differences between the various studies in Table 1, several similarities can be identified. In almost all studies, the majority of school children surveyed (at least 50%) voted the

immediate thermal environment within the three central categories of the common thermal sensation scale, i.e. 'slightly cool', 'neutral' and 'slightly warm' (Auliciems 1969; Pepler 1972; Auliciems 1973; Kwok 1997; Kwok 1998). Even when the outdoor climatic conditions were considerably warmer than average, such as those observed in Japan (Kwok & Chun 2003); Singapore (Wong & Khoo 2003); and Taiwan (Hwang et al. 2009; Liang et al. 2012); or cooler (Corgnati et al. 2007; De Giuli et al. 2012), the students' mean thermal sensations were still within the 'neutral' category.

Table 1 also shows the neutral temperatures calculated for each study. Neutral temperature is defined as the temperature in which the greatest percentage of subjects can be expected to vote within the middle ('neutral') category of the ASHRAE 7-point thermal sensation scale. Thermal neutralities in Table 1 show considerable variation. Some ranged from as low as 16-20°C in the cooler climates of England (Auliciems 1969; Auliciems 1973; Teli et al. 2012); to 24°C and 26-27°C in sub-tropical Australia (Auliciems 1975) and Hawaii (Kwok 1998) respectively. Within the warmer climates of Taiwan and Singapore, school children were found to be neutral at temperatures around 28-29°C (Wong & Khoo 2003; Hwang et al. 2009). This broad relationship between indoor neutralities and outdoor climatic environment seems consistent with the adaptive comfort hypothesis (e.g. Humphreys, 1978; de Dear & Brager, 1998) and previous field studies involving adults in both AC and NV environments in similar climates (e.g. Humphreys 1978; de Dear et al. 1991; Busch 1992; Nicol et al. 1999).

From a comparison of their Singapore results with previous field studies involving school children, Wong and Khoo (2003) concluded that the differences in thermal neutralities were likely due to the students' adaptation to, and tolerance of, higher temperatures in warmer climates. While the specific causal mechanisms behind this association are unclear, they suggested that the physiological (acclimatisation), psychological (expectation and habituation) and physical (clothing adjustment) adaptations observed in adult populations could also be relevant school children.

1.1 Issues related to the comfort standards

Current comfort standards, such as ISO 7730 (ISO 2005), EN 15251 (CEN 2007) and ASHRAE Standard 55 (ASHRAE 2013), determine design values for operative temperatures in indoors based on the heat-balance and adaptive thermal comfort models. Since no children were included in Fanger's (1970) original heat-balance thermal comfort research behind PMV, there is no assurance that results obtained from field studies in offices or universities, or experiments conducted in climate chambers, will accurately reflect the thermal sensations and preferences of school children (ter Mors et al. 2011; Teli et al. 2012). Indeed, many studies have demonstrated that predictions by Fanger's (1970) PMV-PPD model underestimate the actual thermal sensation of children i.e. children have been previously been noted to express warmer sensations than predicted by the PMV-PPD model (Kwok 1998; Kwok & Chun 2003; Wong & Khoo 2003; Zeiler & Boxem 2009; ter Mors et al. 2011). Furthermore, Teli et al., (2012) also revealed that children's thermal preferences were cooler than those predicted by the adaptive standard in EN15251 (ter Mors et al. 2011; Haddad et al. 2013).

Many researchers have proposed reasons for the discrepancies between the thermal sensations of children and the PMV predictions. In comparison with adults, children are generally less sensitive to temperature changes (Humphreys 1977); have a faster rate of heat loss (McCullough et al. 2009); and have a greater sensitivity to changes in their core temperature (Anderson & Mekjavic 1996). Differences in metabolic rates of children and adults for typical indoor activities may possibly explain the differences in their thermal sensations when exposed to the same temperatures (Havenith 2007).

1.2 Effects of classroom temperature on school performance

A few studies conducted in the 1960s and 1970s suggest that moderate changes in room temperature affect children's ability to perform mental tasks requiring concentration, such as coding tests, multiplication problems, short-term memory retention, reading speed and comprehension (Pepler & Warner 1968; Wyon 1970; Wyon et al. 1979), and the impacts can be both positive and negative; for example speed of multiplication problems was reduced by higher temperatures in Pepler and Warners' study (1968) and yet their accuracy went up. From their extensive review of the research literature, Mendell and Heath (2005) found that warmer temperatures (above 24°C) tend to reduce performance, while colder temperatures (below 22°C) reduce manual dexterity and speed (Wyon et al. 1979; Kevan & Howes 1980; Levin 1995). However, these temperature ranges may be dependent on the climate zones in which the study is being conducted. For example, Auliciems (1972) found that British schoolchildren experienced optimal learning conditions at around 16°C.

The influence of moderately elevated temperatures on student performance was investigated in a recent series of field experiments conducted in Danish classrooms (Wargocki & Wyon 2006; Wargocki & Wyon 2007). The performance of various schoolwork performance tasks, from reading to mathematics, by 10-12 year old Danish children was measured during weeks in which moderately elevated classroom temperatures were avoided (by cooling from 25°C to 20°C). The students' speed and accuracy of task performance was assessed and the results indicated that reductions in the classroom temperature had a positive effect on Danish students' performance. As temperatures decreased from 25°C to 20°C, the average (normalised) speed of the performance tasks increased by approximately 2% per 1°C temperature decrease. However, changes in temperature did not have any measurable effect on the number of normalised errors (Wargocki & Wyon 2006; Fisk & Seppanen 2007; Wargocki & Wyon 2007), partially confirming the findings of Pepler and Warner discussed above (1968).

Despite the number of studies on the effects of temperature on children's schoolwork, there is relatively little information on whether students perform better (or worse) in air-conditioned (AC) or naturally ventilated (NV) environments and it is inconsistent. Studies conducted in the US during the 1950s and 1960s found that students performed better in thermally conditioned (AC) classrooms than in those without any form of heating or cooling (NV) (Pepler & Warner 1968; Pepler 1972). In one of the earliest recorded studies on the influence of temperature in AC classrooms on learning, Pepler and Warner (1968) studied six groups of six students in a climate-controlled chamber. Each group of students performed simulated schoolwork with chamber temperatures ranging from 17 to 33°C. It was found that as temperatures increased from 17 to 27°C, the students' speed of work decreased by 7%, whereas the rate of errors was highest at 17°C and lowest at 27°C which represents a 17% improvement (Pepler & Warner 1968).

In a similar study, Schoer and Shaffran (1973) reported three experiments in which 10 to 12 year old students in matched pairs were assigned to either a NV classroom (temperature was 26°C) or to an adjacent AC classroom (temperature of 22.5°C). Nineteen different tasks, ranging from simple and repetitive tasks (such as crossing out certain letters in a text) to school exercises (such as coding numbers onto machine-readable punch cards), were applied to each group every school day for 6-8 weeks. The students' performance was significantly better in the AC classroom by 5.7% (Schoer & Shaffran 1973). However, the differences reported in these case studies could have been influenced by external factors. For example, it is likely the subjects knew they were taking part in an experiment because they were driven to the experimental classrooms and instructed by experimenters and not their normal class

teachers. Also, the students knew they were being tested as each test was timed with a stopwatch, and by talking to each other across the duration of the study they might have known there was a difference in temperature between the two classrooms. According to Wargoeki and Wyon (2007), the observed differences in performance could have been due to a gradual process of discouragement and growing resentment between two groups of pupils.

Although Mendell and Heath (2005) provide a comprehensive review of the effects of temperature on student's classroom performance, several studies, such as those covered by Wyon (1970), were not included. In these experiments, three parallel classes of 9-10 year old children were exposed to each of the three classroom temperatures (20°C, 27°C and 20°C) for two hours. This corresponded with another study in which four classes of 11-12 year old children were exposed to 20°C and 30°C in the morning and afternoon (Holmberg & Wyon 1969). All temperatures were encountered in a balanced order. The children performed a number of numerical tasks (addition, multiplication, number-checking) and language-based tasks (reading and comprehension, supplying synonyms and antonyms) so that their rate of working and the number of errors could be quantified. Compared to 20°C, the children's performance was significantly lower for both tasks at 27°C and 30°C, especially during the afternoon as children started to fatigue (Holmberg & Wyon 1969). The findings suggest that rate of work in the numerical tasks, and reading comprehension and reading speed were reduced by raised temperatures, as the magnitude of the negative effect of temperature on performance was as great as 30% (Wyon 1970). These results were later supported by Wyon et al., (1979) in which the reading speed, comprehension and multiplication tasks performed by high school students (17 years of age) began to decline as temperatures reached 27°C.

1.3 Aims of the current study

Considering school students spend up to one third of the day inside classrooms, the significance of providing comfortable environments for learning is obvious (Haddad et al. 2013). Unfortunately, how the thermal environment of classrooms affects students' comfort and performance has been understudied over the last 40 years, and the amount of Australian work in this topic is negligible. Whereas PMV tends to exaggerate warm discomfort for adults, it seems to underestimate children's actual thermal sensation, but there is no coherent explanation for this in terms of metabolic differences to date.

The literature on the impacts of thermal environment on children's school performance is, at best, inconsistent. Furthermore, the overwhelming majority of the research comes from colder climate zones than Australia, so the effects of acclimatization to the Australian climatic context is overlooked by these generalisations. Nonetheless, the literature demonstrate that increased classroom temperatures can have a negative effect on children's comfort and academic achievement; discomfort decreases the children's attention span when temperature and humidity exceed their comfort zone (Wyon 1970; Kwok 1997; Mendell & Heath 2005; Zeiler & Boxem 2009). But the actual span of temperatures comprising children's comfort zone is probably related to the thermal environment, both internal and out, to which they have become adapted – sliding up the temperature scale in warmer climates, and down the scale in cooler climates. By logical extension, therefore, air conditioning classrooms in Australia's summer potentially causes children to "acclimatise" to artificially cooler indoor conditions.

This study aims to:

- understand students' perception of classroom thermal environment, particularly in relation to current adaptive comfort guidelines

- understand students' attitudes towards different ways of adjusting their level of thermal comfort
- investigate thermal performance (overheating) of Australian school buildings
- apply ASHRAE adaptive comfort model as a rational basis for deciding whether or no classroom is overheating during summer.

2 Methods

2.1 Survey questionnaire and subjects

Questionnaire surveys and instrumental measurements of indoor thermal comfort parameters were carried out simultaneously in nine Australian schools during the late summer period of 2013. A total of 2,850 responses were obtained from nine schools, with the age of survey participants ranging from 10 to 18 years. The surveys were administered by the regular classroom teacher twice a day (morning and afternoon) in a mixture of classrooms with and without mechanical cooling systems (Air-Conditioned AC, Evaporative-Cooled EC and Naturally-Ventilated NV). And even though some classrooms were equipped with air conditioners, using operable windows and ceiling fans was regarded as the primary method of space cooling. The survey period varied between schools from one to three weeks. The participating schools are located generally in temperate, sub-tropical and semi-arid climate zones (Bureau of Meteorology 2013). Each school's ventilation type, climate zone and sample size (N) are summarised in Table 2.

Table 2 Summary of participating schools and students

Participating School		Ventilation Type	Climate Zone	Respondent Sample	
				N	%
Primary School	A	NV	Warm temperate	65	2.3
	B	AC	Warm humid summer, mild winter	428	15.0
	C	AC	Warm temperate	374	13.1
	D	EC	Hot dry summer, cool winter	300	10.5
	E	NV	Mild temperate	474	16.6
	F	EC	Hot dry summer, cool winter	450	15.8
High School	G	EC	Hot dry summer, cool winter	321	11.3
	H	NV	Warm temperate	214	7.5
	I	AC	Mild temperate	224	7.9
Total				2,850	100.0

Note: AC (Air-Conditioned), EC (Evaporative-Cooled), NV (Naturally-Ventilated)

The questionnaire recorded the information of the students' thermal sensation, thermal preference, activity level and clothing insulation (Table 3). Teachers checked questionnaire items prior to conducting the survey, examining whether the description was comprehensible to the students or not. ASHRAE's seven-point scale, with each response given a numerical value from -3 to +3 (i.e. *cold* = -3, *slightly cool* = -2, *neutral* = 0, *slightly warm* = +1, *warm* = +2, *hot* = +3), was used for the respondents to rate their thermal sensation by asking, "Please circle how you feel right now?" Students' thermal preference was rated with the McIntyre scale by asking, "Would you like to be?" on a three-point scale coded from -1 to +1 (i.e. *colder* = -1, *no change* = 0, *warmer* = +1).

Table 3 Summary of questionnaire items, scales and numerical coding used in the analysis

Questionnaire item	Measuring scale or answer coding
Thermal sensation	Hot (+3) Warm (+2) Slightly warm (+1) Neutral (0) Slightly cool (-1) Cool (-2) Cold (-3)
Thermal preference	Warmer (+1) No change (0) Colder (-1)
Activity level (MET)	Sitting (1.2) Active (3.0)
Clothing insulation (Clo)	Dress (0.54) Dress, Jumper (0.79) Dress, Jacket or Blazer (0.90) Skirt, Shirt (0.54) Skirt, Shirt, Jumper (0.79) Skirt, Shirt, Jacket or Blazer (0.90) Shorts, Shirt (0.36) Shorts, Shirt, Jumper (0.61) Shorts, Shirt, Jacket or Blazer (0.72) Long pants, Shirt (0.57) Long pants, Jumper (0.82) Long pants, Jacket or Blazer (0.93)

(from ASHRAE Standard 55-2013)

In relation to activity level, teachers instructed the students to check 'Sitting' box if they had been sitting in the classroom for the 30 minutes prior to completing the survey. If the students had come from activities such as physical education, dance or outdoor playtime, they were guided to tick the 'Active' box. The students' activity level recorded on the questionnaire as either 'Sitting' or 'Active' were equated to metabolic rates, MET = 1.2 and 3.0, which are corresponding to typical office sedentary activity and dancing/exercise respectively in ASHRAE 55 (2013). Assigning corresponding metabolic rates from the current comfort standards to the students' activity levels requires a special attention because the values appended in the comfort standards are based on an average adult. However, while the survey samples comes from a broad range of age groups (10~18 years), detailed information about the participants' demographic and physiological characteristics, including age, gender, body weight and body surface area were not collected. Therefore, adjustments to the compendium values of metabolic rates could not be made. One of the only field studies of children's

metabolic rate in classroom settings by Havenith (2007) provide students' metabolic rate data for typical school activities. However the specific climatic setting (Northern European winter) of Havenith's study does not encourage extrapolation of his findings to places like Australia. School children in Northern European winter are possibly more sedentary than their counterparts in more benign climatic settings like Australia, where they are more likely to be actively running around outdoors during mid-morning recess, lunch-hours, or even during the brief class change-overs. Moreover, Havenith's data consisted of a very small number of subjects ($N = 1 \sim 5$ for each subject group). Considering the ethnic diversity of Australia, the sample number in Havenith's database seemed insufficient to warrant generalization.

Clothing insulation was estimated for each subject. Twelve typical clothing ensembles were created based on the combinations of school uniform garments. Insulation of the students' chairs, typically made of polypropylene, was estimated to have negligible incremental insulation. The clothing ensembles and corresponding clo values are also attached in Table 3.

2.2 Classroom indoor climate instrumentation and procedures

Physical indoor climatic data were collected at 15-minute intervals from each classroom. PT100 resistance temperature devices were calibrated and used to record air temperature and globe temperature. Air speed was registered with an Accusense F900 hot-wire anemometer with range of $0.15 - 5 \text{ m/s} \pm 10\%$ and humidity was recorded by Vaisala INTERCAP Humidity and Temperature Probe HMP60. The sensor package was typically wall-mounted between 2 and 2.5m above floor-level within each classroom and connected to the internet through each school's internal wifi. This equipment configuration put the sensors outside the classroom's occupied zone, but was deemed necessary to protect from student tampering. In all of the classrooms surveyed our pilot investigations found no evidence that temperatures recorded by our wall-mounted instrument package differed significantly from those experienced by the students, as a result of vertical thermal stratification or radiant asymmetry. However it is possible that our air speed sensors were underestimating speeds in the free atmosphere within the occupied zone of some of our sample classrooms.

Individual survey responses were manually matched with corresponding time-stamped indoor thermal environmental data for subsequent analysis. The dataset received careful quality verification throughout this merge process. A range of comfort indices were then calculated, including operative temperature (T_o is an arithmetic average of both air and mean radiant temperatures), mean air velocity (V_{air}), relative humidity (RH), metabolic rate (MET), clo value (Clo), Actual Mean Vote (AMV is the mean value of the thermal sensation votes recorded by the subjects on the seven-point scale), Predicted Mean Vote (PMV was calculated with the ASHRAE ComfortTool) and Predicted Percentage Dissatisfied (also calculated with the ASHRAE ComfortTool).

2.3 Overheating/cooling analysis

As an index of classroom overheating or overcooling, the number of occupied hours in which indoor operative temperature exceeded the acceptable adaptive temperature limits, as prescribed in ASHRAE Standard 55-2013, was calculated. It is acknowledged that the adaptive model was developed from naturally ventilated spaces and so its scope of application should be limited to such spaces, but for the classrooms in this study having an air conditioning system, thermal conditioning of the space was primarily regulated through operable windows (the A/C systems in operation were invariably of the split-system type). Furthermore the actual usage of those split-system air conditioners was not monitored. Therefore data from every school, regardless of the presence or absence of an air conditioning system, have been retained in this overheating/cooling analysis. The ASHRAE

Standard 55's adaptive upper and lower 80% acceptability limit for each day of the monitoring period was defined based on the weighted, running 7-day mean outdoor temperature (ASHRAE 55-2013) referring to Bureau of Meteorology's closest weather station. Observed hourly indoor operative temperature of each classroom during school operating hours (from 8:30AM to 3:30PM) were then assessed as falling inside or outside the 80% acceptability band.

3 Results

3.1 Thermal comfort indices

Descriptive statistics including mean, range and standard deviation (S.D.) of each index are listed in Table 4. Indoor operative temperatures (T_o) recorded during this study fell within the range of 18.2 to 31.1°C, with a mean value of this summer season being 25.1°C. With a negligible mean speed of 0.07 m/s, air movement within the occupied zone exerted a marginal effect on subjects' thermal sensation. RH ranged from 26% to 78% with an average of 51%. Mean metabolic rate was 1.5 met indicating that most of the students were sitting in the classroom prior to the questionnaire being administered. Clothing insulation estimates were close to those typically assumed for adult office workers during the summer season (ASHRAE, 2010), with an average value of 0.45 Clo. The Actual Mean Vote on the thermal sensation scale (AMV = +0.45) for all student samples fell mid-way between *neutral* (0) and *slightly warm* (+1). The mean of the predicted PMV index across this sample was +0.34. The respondents' AMV (actual sensation vote) was marginally warmer than PMV (predicted sensation vote) by about 0.1 thermal sensation units. On the basis of the instrumental observations of the sample classrooms the PPD index predicted that 24% of the subjects, on average, would be dissatisfied with their thermal environment.

Table 4 Statistical summary of classroom indoor climate and thermal comfort indices

Index	Mean	Min.	Max.	S.D.
T_o (°C)	25.1	18.2	31.1	2.2
V_{air} (m/s)	0.07	0.00	0.62	0.08
RH (%)	51.4	25.97	78.23	9.5
MET	1.51	1.20	3.00	0.68
Clo	0.45	0.36	0.93	0.13
AMV	+0.45	-3.00	+3.00	1.38
PMV	+0.34	-2.50	+3.00	0.98
PPD (%)	24.2	5.00	99.4	25.6

Note: AMV, PMV and PPD were averaged results from individual calculations for each subject

3.2 Subjective assessment of the indoor thermal environment

Fig.1 illustrates the distribution of indoor operative temperature (T_o) recorded during the summer survey period. Each bar shows the number and percentage of survey samples falling within each operative temperature bin. Approximately 90% of observed operative temperature measurements fell within the range of 22 to 29°C.

Statistical distributions of the survey participants' perception of the thermal environment are summarised in Fig. 2. 42.2% of the students expressed their thermal sensation as *neutral*. More than twice as many votes fell in *warmer-than-neutral* region of the scale (i.e. including *slightly warm* 16.9%, *warm* 12.2%, and *hot* 10.4%) compared to the votes on *cooler-than-neutral* (i.e. including *slightly cool* 11.5%, *cool* 4.1%, and *cold* 2.6%). The PPD thermal comfort index is based on the assumption that people voting in the middle three categories

(i.e. *slightly cool* -1, *neutral* 0, or *slightly warm* +1) of the 7-point thermal sensation scale are satisfied with their thermal environment. Extending this assumption to the Actual Mean Votes cast during this survey, 70.6% of the students were satisfied with their classroom thermal condition. By logical extension, votes on +2 (*warm*), +3 (*hot*), -2 (*cool*), or -3 (*cold*) can be regarded as expressions of thermal dissatisfaction, which in this survey amounted to 29.4%. This indicates that the classrooms in which the survey was conducted failed to meet the industry-accepted minimum standard of 80% acceptability, as recommended in regulatory documents such as ASHRAE's Standard 55 (ASHRAE, 2010). Thermal preference votes were consistent with the distribution of thermal sensation votes, and 41.8% of the survey participants wanted to be *cooler*, whereas only 11.3% wanted to be *warmer*.

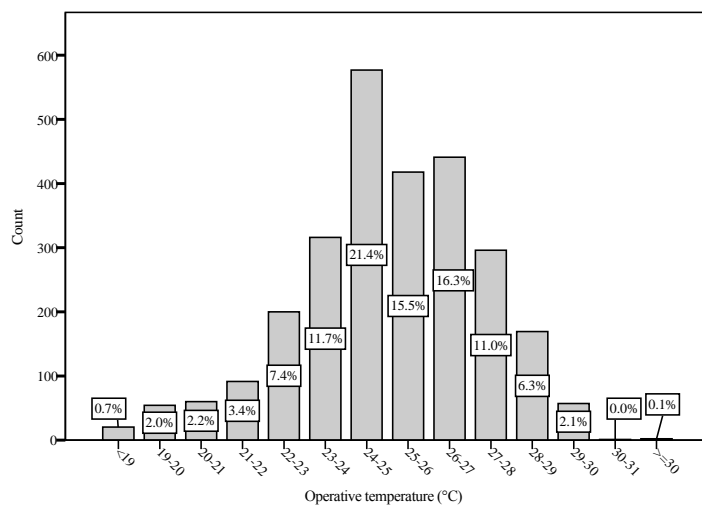

Fig. 1 Histogram of indoor operative temperature binned at 1°C intervals

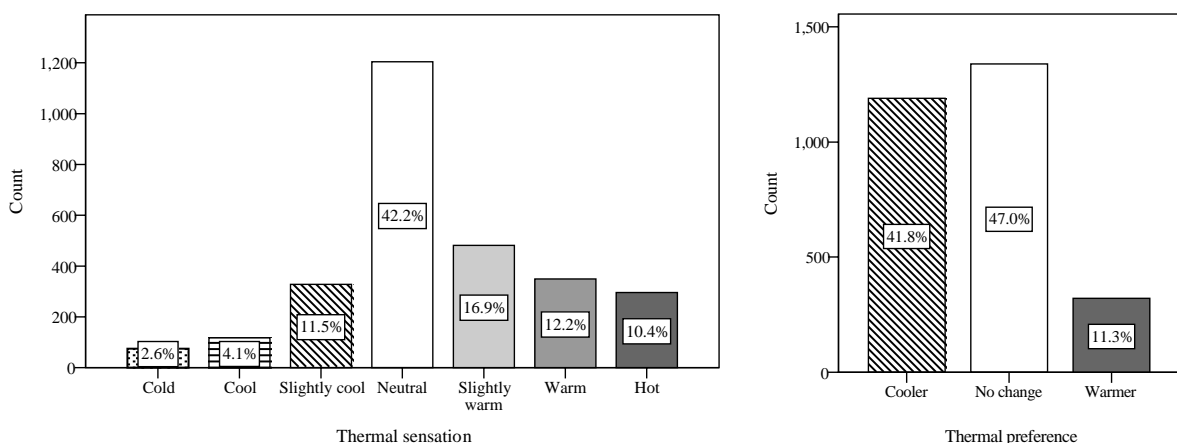

Fig. 2 Distribution of thermal sensation (left) and thermal preference (right) votes

Statistical distributions of the survey participants' perception of the thermal environment are summarised in Fig. 2. 42.2% of the students expressed their thermal sensation as *neutral*.

More than twice as many votes fell in *warmer-than-neutral* region of the scale (i.e. including *slightly warm* 16.9%, *warm* 12.2%, and *hot* 10.4%) compared to the votes on *cooler-than-neutral* (i.e. including *slightly cool* 11.5%, *cool* 4.1%, and *cold* 2.6%). The PPD thermal comfort index is based on the assumption that people voting in the middle three categories (i.e. *slightly cool* -1, *neutral* 0, or *slightly warm* +1) of the 7-point thermal sensation scale are satisfied with their thermal environment. Extending this assumption to the Actual Mean Votes cast during this survey, 70.6% of the students were satisfied with their classroom thermal condition. By logical extension, votes on +2 (*warm*), +3 (*hot*), -2 (*cool*), or -3 (*cold*) can be regarded as expressions of thermal dissatisfaction, which in this survey amounted to 29.4%. This indicates that the classrooms in which the survey was conducted failed to meet the industry-accepted minimum standard of 80% acceptability, as recommended in regulatory documents such as ASHRAE's Standard 55 (ASHRAE 2013). Thermal preference votes were consistent with the distribution of thermal sensation votes, and 41.8% of the survey participants wanted to be *cooler*, whereas only 11.3% wanted to be *warmer*.

Fig. 3 shows the distribution of survey participants' thermal preference votes in relation to their thermal sensation votes. As thermal sensation increased (i.e. from cold to hot), the percentage of subjects voting for 'want cooler' generally increased. As one might expect, the percentage of those preferring to be warmer (i.e. 'want warmer' responses) tended to increase as thermal sensation decreased from warm to cool. However, this pattern is slightly asymmetrical with the percentage of subjects wanting to feel cooler under warmer-than-neutral conditions significantly higher (69-87%) than the percentage of subjects wanting to feel warmer under cooler-than-neutral conditions (36-61%). This probably reflects the season in which the survey was conducted, with preferences to return from warm to neutral being usually stronger than the opposite during the warm season (Brager *et al.* 2004). The apparent inconsistency between thermal preferences expressed by respondents who were feeling cooler-than-neutral is counterintuitive. For example 28% of respondents who felt cold (thermal sensation of -3) expressed a preference to feel even cooler. In order to test the hypothesis that the "right-here-right-now" preface to the questionnaire may not have been fully understood by the younger subjects in our sample, we cross-tabulated the thermal preference votes for all subjects voting -3 on the thermal sensation scale. A Chi Square test on this cross-tabulation indicated no significant differences between primary and high school students in our sample (Chi Squared = 1.55, df=2, p>0.05). Notwithstanding the statistical insignificance, most of the contradictory preference and sensation cases were primary school children.

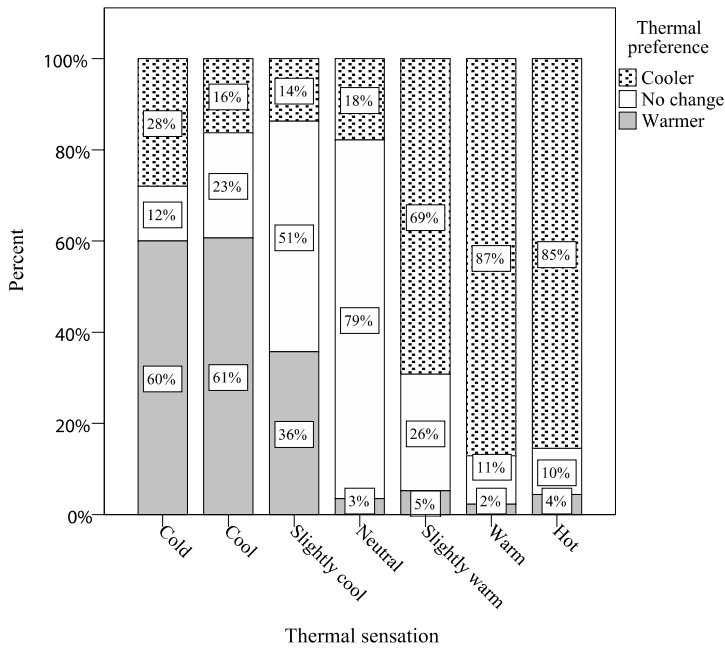

Fig. 3 Cross-tabulated thermal sensation and thermal preference

Fig. 4 illustrates the mean values and 95% confidence intervals for AMV and PMV categorized by indoor operative temperature binned by 1°C intervals. This figure shows how actual (AMV) and predicted (PMV) thermal sensations change depending on the indoor operative temperature. Below 23°C there seems to be no significant change in the subjects' thermal sensation, staying close to *neutral*. However, as indoor operative temperatures exceed 23°C there is a steady increase in mean thermal sensation. There were discrepancies and agreements between AMV and PMV index, depending on the temperature. From 22 up to 25°C the subjects' observed thermal sensations (AMV) were warmer than those predicted using the PMV-PPD model. AMV and PMV were well matched when operative temperature was within the range of 25-27°C. After operative temperature exceeded 27°C, PMV tended to overestimate the students' thermal sensation.

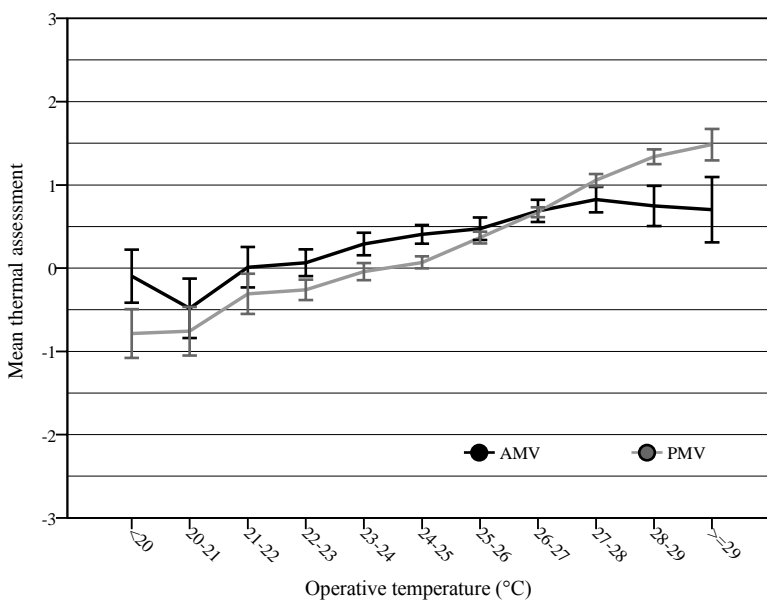

Fig. 4 Actual (AMV) and predicted (PMV) mean thermal sensation in relation to indoor

operative temperature. Error bars represent 95% confidence intervals

In order to investigate preferred temperature and neutral temperature, students' thermal preference votes and thermal sensation votes were binned into 0.5°C intervals of indoor operative temperature. Note that the subjects who were engaged in activities other than 'Sitting' were excluded from the estimation of both preferred and neutral temperature (i.e. non-sedentary subjects were excluded in the analysis). Thermal preference votes within each half-degree of operative temperature bin became the basis of the probit regression models (depicted in Fig. 5). The z -statistic, with associated p -values for the regression coefficients, and the chi-square test indicate that the fitted model was statistically significant ($p < 0.001$). The point of intersection between 'want cooler' and 'want warmer' probit models is taken to represent the group's preferred temperature - in this analysis, 22.2°C.

Fig. 6 shows the mean thermal sensation votes plotted against operative temperature. The linear regression model was weighted by number of responses within each half-degree operative temperature bin. The regression model ($r^2 = 0.76$, $p < 0.001$ for regression coefficient and constant) fitted to bin-mean vote is:

$$\text{mean thermal sensation vote} = 0.124 \times T_o - 2.777 \quad (1)$$

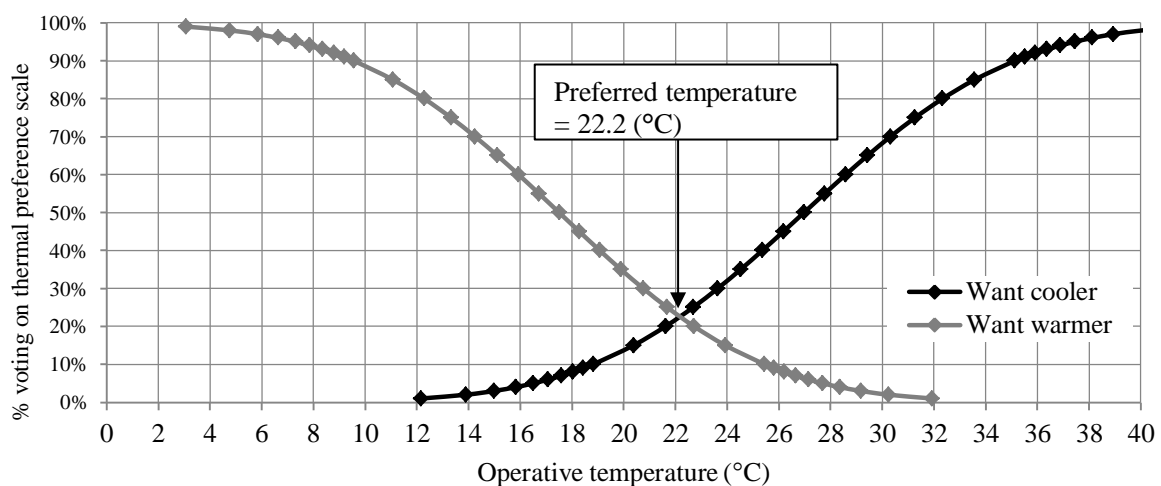

Fig. 5 Probit regression models fitted to thermal preference percentages

The neutral temperature estimated by this new equation (above) is 22.4°C, approximately the same as the preferred temperature of 22.2°C. According to the equation, on average, eight degrees of operative temperature change shifts the group's mean thermal sensation one point on the seven-point scale (one divided by the regression coefficient of 0.124 in Equation 1). In adaptive thermal comfort theory we regard the gradient of this regression equation as being inversely proportional to the adaptability of the building occupants under analysis; a very shallow gradient indicates the subjects were able to adapt very effectively to changes in temperature (instead of feeling over- or under-heated and shifting their thermal sensation accordingly), whereas a steep regression line suggests the subjects were not successful in adapting because they quickly felt warm (or cool) as the room temperature shifted away from their neutrality. At more than eight degrees per thermal sensation unit, the regression

equation shows this sample to be *remarkably successful at adapting* to changes in indoor temperature.

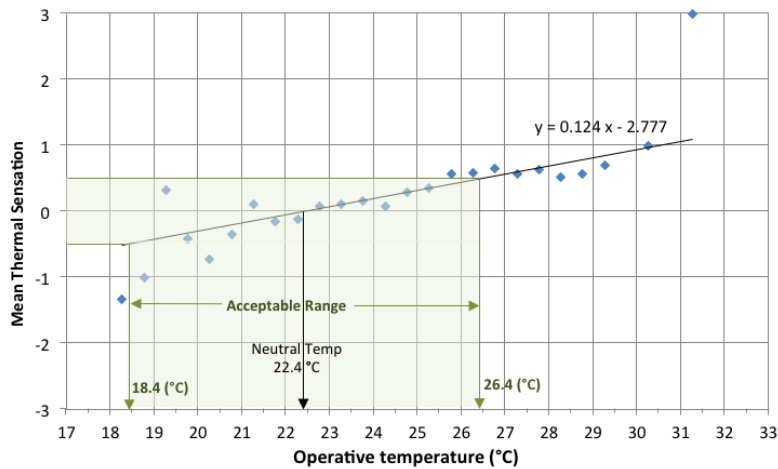

Fig. 6 Mean thermal sensation votes (-3 = cold, through 0 = neutral to +3 = hot) related to indoor operative temperature. The regression equation is weighted by number of responses.

Regression equations describing the dependence of sample mean thermal sensation on mean indoor operative temperature are often used to define acceptable temperature limits for a particular sample. In the case of ASHRAE 55-2013, the so-called “comfort zone,” as expressed on a temperature-humidity graph (psychrometric chart), has its boundaries defined as -0.5 PMV on the cool side and +0.5 PMV on the warm side. The logic behind this definition is encapsulated in the Predicted Percentage Dissatisfied (PPD) index. In classic thermal comfort theory PPD reaches its minimum value when PMV equals zero (i.e. neutrality). That is, when the average person feels thermally neutral, we can expect a minimum of complaints from the entire group in that environment. Minimum PPD is set to 5%, reflecting the fact that we can never satisfy all of the occupants within a space with a single thermal environment. As PMV deviates from “neutral” in both the warm or cool direction, the PPD starts to increase. When the group’s mean thermal sensation (PMV) equals plus or minus 0.5, PPD climbs to 10% (i.e. one in ten people in the group will have a thermal sensation falling outside the satisfactory or acceptable central three categories of -1, 0, +1 on the 7-point sensation scale). To this PPD of 10% dissatisfied ASHRAE 55-2013 adds another 10% dissatisfied resulting of *local* discomforts like draft, vertical temperature stratification and plane radiant asymmetry, bringing the total percentage dissatisfied from global and local discomforts combined to 20%. Eighty percent acceptability (i.e. 20% dissatisfied) is the internationally agreed design target and the same definition of acceptable mean thermal sensations is adopted in the International Standards Organization’s thermal comfort standard, ISO 7730 (2005); $-0.5 < PMV < +0.5$, corresponding to $PPD=10\% +$ another 10% dissatisfaction from local discomforts, bringing the total dissatisfied to 20%

This same fundamental logic, as adopted in ASHRAE (55-2013) and also ISO (7730-2005) to define their comfort zones, can be applied to the results obtained in this thermal comfort survey of school children in the present study, but with key difference - rather than use *predicted* mean thermal sensations (PMV), we have the advantage of *actual* mean thermal sensations, as depicted in Fig. 6. The mean indoor operative temperatures corresponding to group mean thermal sensations of +0.5 and -0.5 stretch from 18.4°C up to 26.4°C (see shaded region on Fig. 6), and this acceptable comfort zone can be compared to that of ASHRAE 55. Based on the mean outdoor air temperature of the survey month (Bureau of Meteorology), 80% acceptable operative temperature limits were calculated (Table 5). In general, the adaptive

model estimated 21.0~28.0 °C as 80% acceptable operative temperature range for the 9 schools. These Australian school children felt comfortable in a lower range of operative temperature (18.4~26.4°C) than that predicted by the adaptive model (21.0~28.0°C).

Table 5 ASHRAE 55's 80% acceptable operative temperature range for 9 schools

School	Mean monthly outdoor air temperature (°C)	Lower 80% acceptability limit (°C)	Upper 80% acceptability limit (°C)
A	22.7	21.3	28.3
B	22.7	21.3	28.3
C	22.1	21.2	28.2
D	16.5	19.4	26.4
E	22.0	21.1	28.1
F	21.2	20.9	27.9
G	22.5	21.3	28.3
H	23.0	21.4	28.4
I	22.3	21.2	28.2
Average of 9 schools		21.0	28.0

3.3. Over-heating/cooling analysis

Fig. 7 illustrates the number of hours falling beyond ASHRAE 55's 80% acceptable operative temperature range. Out of total 1,341 school operating hours during the monitoring period, the percentage of hours exceeding the adaptive 80% upper acceptability limit was 7.6% (102 hours). The number of occupied hours that indoor operative temperatures dropped below the lower 80% limit was negligible (0.9%). Differences in the total number of occupied hours between each school are due to the different periods in which temperature was measured at the various schools. The highest percentage of overheated hours during the measurement period was reported in School F (23.1%), followed by School I (11.6%), in which classroom were equipped with either air-conditioning or evaporative-cooling system. It should be noted that the temperature data in this analysis could include hours in which the classroom was unoccupied. Therefore the overheating hours of AC or EC spaces could simply be the result of the air conditioning system not being used on hot days if the classroom happened to be unoccupied.

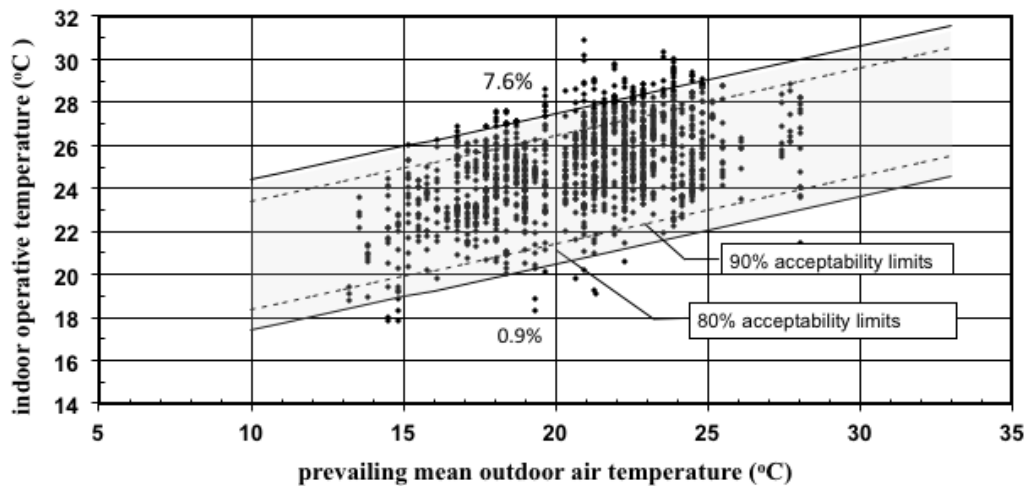

School	Ventilation type	Total occupied hours	Above upper 80% limit		Below lower 80% limit	
			Total hours	Percent	Total hours	Percent
A	NV	49	0	0.0	2	4.1
B	AC	133	0	0.0	0	0.0
C	AC	98	0	0.0	3	3.1
D	EC	300	19	6.3	3	1.0
E	NV	77	0	0.0	1	1.3
F	EC	182	42	23.1	0	0.0
G	EC	105	2	1.9	3	2.9
H	NV	173	13	7.5	0	0.0
I	AC	224	26	11.6	0	0.0
Total		1,341	102	7.6	12	0.9

Fig. 7 Scatter plot of hourly indoor operative temperature compared to ASHRAE Standard 55's 80% and 90% thermal acceptability limits

4 Discussion

This paper presents results from a thermal comfort study of nine Australian schools, conducted in the summer months of early 2013. The survey participants' subjective assessments of thermal environment using thermal sensation and preference rating scales presented in a "right-here-right-now" questionnaire were statistically analysed and compared with the corresponding time-stamped climatic data measured on the site. While this survey was admittedly based on a small sample of schools, there is a sufficient empirical basis for proposing an acceptable range of indoor environmental temperatures for school classrooms during summer months.

Both linear and probit regression analyses estimated that an indoor operative temperature of about 22.5°C was the students' neutral and preferred temperature. This is generally cooler than we expect of adults under the same thermal environmental conditions. Working on the industry-accepted assumption that an acceptable range of indoor operative temperatures corresponds to mean thermal sensations of -0.5 through +0.5 (ASHRAE 2013; ISO 2005), the present analysis indicates an acceptable summertime range for primary and high school students from about 18.5 through to about 26.5°C operative temperature.

Notwithstanding the physiological differences between adults and children, it is important to understand the unique characteristics of school environments compared to those typical of climate chambers, offices and universities (i.e. environments in which the thermal comfort of adults has been investigated). School children are often engaged in a wider range of activities

(outdoor playtime occurs twice a day) in more densely occupied rooms (between 20 to 40 students per class) with limited adaptive opportunities (students typically wear compulsory uniforms and any environmental controls are operated by the teachers) (Teli et al. 2012). These differences can be expected to affect the students' perceptions of comfort, the thermal conditions within school and classroom environments must be considered carefully when analysing field study findings (Zhang et al. 2007).

Speculating on the possible cause of this anomaly, perhaps the current generation of Australian school children are adapting to (Brager & de Dear 1998; de Dear & Brager 1998), or even becoming *addicted* to a narrower band of indoor temperatures as a result of their long exposures to air-conditioning (Cândido *et al.* 2010). The adaptive theory of thermal comfort suggests that our comfort expectations and tolerance are defined from own thermal experience – we adapt to the range of temperatures to which we are exposed, and the exposures that count most are those occurring most recently. Most of the school children comprising this current sample were born since there was a dramatic increase in AC penetration rates in the residential sector in this country. There was a doubling from 25% to over 50% between 1999 and 2004 (Wilkenfeld 2004) and the trend seems certain to continue in the foreseeable future. Numerous explanations have been offered for this sudden change in the way Australians live, but probably the most compelling is simply the fact that the Australian market experienced a sudden decrease in retail price of air conditioning equipment when our market was opened up to cheap product sourced mainly from China. Air conditioning equipment, most typically simple split systems, became significantly more affordable in the late 1990s and Australian residential consumers responded positively.

The “air-conditioning addiction” hypothesis was reinforced by responses to the behavioural questions included in the questionnaire for this project. There was an item specifically asking students to identify their *preferred thermal adaptive behaviours* from a list of common options. ‘*Use air-conditioner*’ emerged as the most common selection, followed by ‘*do nothing*’ and ‘*use fans*.’ In the survey’s naturally ventilated classrooms, the percentage voting for ‘*use AC*’ proportionally increased as indoor temperature rose. When indoor operative temperature was greater than 28°C, using an air-conditioner became the overwhelmingly dominant thermal behavioural response suggested by the students.

The major policy question arising from these observations and conjectures is whether or not the State Government (in charge of the education portfolio in the Australian context) should design, build and operate its school building stock in a way that reflects, or even anticipates these comfort pressures to air condition every classroom and buffer their occupants entirely from the natural rhythms of daily weather, season and climate? Putting aside the question of environmental sustainability of such a policy choice, there are strong counter-arguments, including the negative impacts of air conditioning on indoor air quality (especially through vastly reduced ventilation rates), which would adversely affect children’s health and their educational attainment. A majority of the air conditioning equipment being installed across the State’s classroom stock is of the split-system type, and this type of equipment recirculates 100% of the air it conditions; outdoor ventilation air is not a function performed by split systems, so unless the teacher has specifically made an effort to provide supplementary ventilation by opening a classroom window or door to the outside, it is highly likely that the indoor air quality in classrooms with split systems in operation would fall below levels recommended in the relevant standards and guidelines. A critical literature review conducted on indoor air quality impacts on student performance found “suggestive evidence” linking low ventilation rates to decreases in performance (Mendell & Heath, 2005). However that review found the causal linkage of ventilation rate to a variety of adverse health effects such as “sick building syndrome” symptoms was even more compelling than the performance

impacts. Clearly these complex and intertwined issues of indoor air quality, ventilation, student performance and health need to be taken into consideration alongside the present study's findings on thermal comfort before setting any major policy decisions on the question of air conditioning versus natural ventilation in the classrooms of NSW.

On the basis of the research evidence revealed in this project we recommend State education authorities refrain from rolling out air conditioning to *every* classroom in the State, but rather to restrict its installation to classrooms where there is *demonstrable overheating* occurring, and once it is installed in a space, to operate the equipment as the *comfort strategy of last resort*, not as the default. Decisions about where to install air conditioning should rationally be made where there is evidence of systematic overheating; where acceptable classroom temperatures are defined in relation to the adaptive comfort 80% acceptability. Furthermore, in classrooms where air conditioning is already installed, we recommend a policy of operating it if and only if there is an upper acceptable temperature exceedance in progress. We recognise this will involve removal of individual teachers from decisions about when to turn on air conditioning equipment.

Conclusions

- A large field survey of thermal comfort in Australian grade- and high-schools has been conducted during the second half of the summer season.
- Neutral and preferred operative temperatures were about 22.5°C, which falls below predictions of both PMV and adaptive models of thermal comfort.
- This finding reiterates the findings of other researchers, but a coherent explanation of why children's thermal sensations fall below that of adults in the same temperatures has to be developed.
- Despite the lower-than-expected neutrality, the school children in this survey demonstrated considerable adaptability to indoor temperature variations, with one thermal sensation unit equating to approximately eight degrees operative temperature.
- By applying the rule-of-thumb that group mean thermal sensations between -0.5 and +0.5 correspond to the range of acceptable operative temperature, the current survey found an acceptable range of 18.4 to 26.4°C (presumed to be the 80% acceptable range).
- The upper acceptable operative temperature limit of 26.4 falls about one-and-a-half degrees cooler than the conventional adaptive comfort standard (ASHRAE 55-2013) predicts when applied to the outdoor temperatures observed in this survey.

References

- Anderson, G.S. & Mekjavic, I.B., 1996. Thermoregulatory responses of circum-pubertal children. *European Journal of Applied Physiology and Occupational Physiology*, 74(5), pp.404–410.
- ASHRAE, 2013. ANSI/ASHRAE Standard 55-2013: Thermal Environmental Conditions for Human Occupancy, American Society of Heating, Refrigerating and Air-Conditioning Engineers, Inc.
- Auliciems, A., 1972. Classroom performance as a function of thermal comfort. *International Journal of Biometeorology*, 16(3), pp.233–246.

- Auliciems, A., 1969. Thermal requirements of secondary schoolchildren in winter. *Journal of Hygiene*, 67(1), pp.59–65.
- Auliciems, A., 1973. Thermal sensations of secondary schoolchildren in summer. *Journal of Hygiene*, 71(3), pp.453–458.
- Auliciems, A., 1975. Warmth and comfort in the subtropical winter: A study in Brisbane schools. *Journal of Hygiene*, 74(3), pp.339–343.
- Bako-Biro, Z. et al., 2012. Ventilation rates in schools and pupils' performance. *Building and Environment*, 48(2), pp.215–223.
- Brager, G.S. & de Dear, R.J., 1998. Thermal adaptation in the built environment: A literature review. *Energy and Buildings*, 27(1), pp.83–96.
- Brager, G.S., Paliaga, G. & de Dear, R., 2004. Operable windows, personal control and occupant comfort. *ASHRAE Transactions*, 2, p.110.
- Bureau of Meteorology, 2013. *Climate Classification*, Bureau of Meteorology. Available at: www.bom.gov.au.
- Busch, J.F., 1992. A tale of two populations: Thermal comfort in air-conditioned and naturally-ventilated offices in Thailand. *Energy and Buildings*, 18(3-4), pp.235–249.
- Cândido, C., de Dear, R., Lamberts, R. & Bittencourt, L., 2010. Cooling exposure in hot humid climates: Are occupants 'addicted'?, *Architectural Science Review*, 53(1), pp.59-64.
- CEN, 2007. DIN EN 15251 Indoor environmental input parameters for design and assessment of energy performance of buildings addressing indoor air quality, thermal environment, lighting and acoustics, European Committee for Standardization.
- Corgnati, S.P., Filippi, M. & Viazzo, S., 2007. Perception of the thermal environment in high school and university classrooms: Subjective preferences and thermal comfort. *Building and Environment*, 42(2), pp.951–959.
- de Dear, R.J. & Brager, G., 1998. Developing an adaptive model of thermal comfort and preference. *ASHRAE Transactions*, 104(1), pp.145–167.
- de Dear, R.J., Leow, K.G. & Foo, S.C., 1991. Thermal comfort in the humid tropics, field experiments in air-conditioned and naturally ventilated buildings in Singapore. *International Journal of Biometeorology*, 34, pp.259–265.
- Fanger, P.O., 1970. *Thermal Comfort*, Copenhagen: Danish Technical Press.
- Fisk, W. & Seppanen, O., 2007. Providing better indoor environmental quality brings economic benefits. In *CLIMA Conference 2007: Well Being Indoors*. Helsinki, Finland.
- De Giuli, V., Da Pos, O. & De Carli, M., 2012. Indoor environmental quality and pupil perception in Italian primary schools. *Building and Environment*, 56(10), pp.335–345.

- Haddad, S., Osmond, P. & King, S., 2013. Metabolic rate estimation in the calculation of the pmv for children. In *47th International Conference of the Architectural Science Association*. pp. 241–250.
- Havenith, G., 2007. Metabolic rate and clothing insulation data of children and adolescents during various school activities. *Ergonomics*, 50(10), pp.1689–1701.
- Holmberg, I. & Wyon, D.P., 1969. *The dependence of performance in school on classroom temperature*, Malmö, Sweden: School of Education.
- Humphreys, M.A., 1977. A study of the thermal comfort of primary school children in summer. *Building and Environment*, 12(4), pp.231–239.
- Humphreys, M.A., 1978. Outdoor temperatures and comfort indoors. *Building Research and Practice*, 6(2), pp.92–105.
- Hwang, R.L. et al., 2009. Investigating the adaptive model of thermal comfort for naturally ventilated school buildings in Taiwan. *International Journal of Biometeorology*, 53(2), pp.189–200.
- ISO, 2005. ISO 7730 Moderate thermal environments - Determination of the PMV and PPD indices and specification of the conditions for thermal comfort.
- Kevan, S.M. & Howes, J.D., 1980. Climatic conditions in classrooms. *Educational Review*, 32(3), pp.281–292.
- Kwok, A.G., 1997. *Thermal comfort in naturally-ventilated and air-conditioned classrooms in the tropics*. Berkeley: University of California.
- Kwok, A.G., 1998. Thermal comfort in tropical classrooms. *ASHRAE Transactions*, 104(1B), pp.1031–1047.
- Kwok, A.G. & Chun, C., 2003. Thermal comfort in Japanese schools. *Solar Energy*, 74(3), pp.245–252.
- Levin, H., 1995. Physical factors in the indoor environment. *Occupational Medicine: State of the Art Reviews*, 10(1), pp.59–94.
- Liang, H.H., Lin, T.P. & Hwang, R.L., 2012. Linking occupants' thermal perception and building thermal performance in naturally ventilated school buildings. *Applied Energy*, 94(6), pp.355–363.
- McCullough, E.A., Eckels, S. & Harms, C., 2009. Determining temperature ratings for children's cold weather clothing. *Applied Ergonomics*, 40(5), pp.870–877.
- Mendell, M.J. & Heath, G.A., 2005. Do indoor pollutants and thermal conditions in schools influence student performance? A critical review of the literature. *Indoor Air*, 15(1), pp.27–52.

- Ter Mors, S. et al., 2011. Adaptive thermal comfort in primary school classrooms: Creating and validating PMV-based comfort charts. *Building and Environment*, 46(12), pp.2454–2461.
- Nicol, F.J. et al., 1999. Climatic variations in comfortable temperatures: the Pakistan projects. *Energy and Buildings*, 30(3), pp.261–279.
- Pepler, R.D., 1972. The thermal comfort of students in climate controlled and non-climate controlled schools. *ASHRAE Transactions*, 78(1), pp.97–109.
- Pepler, R.D. & Warner, R.E., 1968. Temperature and learning: An experimental study. *ASHRAE Transactions*, 74(1), pp.211–219.
- Schoer, L. & Shaffran, J., 1973. A combined evaluation of three separate research projects on the effects of thermal environment on learning and performance. *ASHRAE Transactions*, 79(1), pp.97–108.
- Teli, D., Jentsch, M.F. & James, P.A.B., 2012. Naturally ventilated classrooms: An assessment of existing comfort models for predicting the thermal sensation and preference of primary school children. *Energy and Buildings*, 53, pp.166–182.
- Wargoeki, P. & Wyon, D.P., 2006. Research report on effects of HVAC on student performance. *ASHRAE Journal*, 48(October), pp.22–28.
- Wargoeki, P. & Wyon, D.P., 2007. The effects of moderately raised classroom temperatures and classroom ventilation rate on the performance of schoolwork by children (RP-1257). *HVAC&R Research*, 13(2), pp.193–220.
- Wilkenfeld, G., 2013. Mandating demand response interfaces for selected appliances: Consultation regulation impact statement. Available at: <http://www.energyrating.gov.au>
- Wong, N.H. & Khoo, S.S., 2003. Thermal comfort in classrooms in the tropics. *Energy and Buildings*, 35(4), pp.337–351.
- Wyon, D.P., 1970. Studies of children under imposed noise and heat stress. *Ergonomics*, 13(5), pp.598–612.
- Wyon, D.P., Andersen, I. & Lundqvist, G.R., 1979. The effects of moderate heat stress on mental performance. *Scandinavian Journal of Work, Environment and Health*, 5(4), pp.352–361.
- Zeiler, W. & Boxem, G., 2009. Effects of thermal activated buildings systems in schools on thermal comfort in winter. *Building and Environment*, 44(11), pp.2308–2317.
- Zhang, G. et al., 2007. Thermal comfort investigation of naturally ventilated classrooms in a subtropical region. *Indoor and Built Environment*, 16(2), pp.148–158.

Proceedings of 8th Windsor Conference: *Counting the Cost of Comfort in a changing world* Cumberland Lodge, Windsor, UK, 10-13 April 2014. London: Network for Comfort and Energy Use in Buildings, <http://nceub.org.uk>

Cold comfort: thermal satisfaction in academia

Simi Hoque¹ and Ben Weil²

1 Dept. of Environmental Conservation, University of Massachusetts-Amherst,
correspondence simih@eco.umass.edu
2 bweil@eco.umass.edu

Abstract

This paper presents preliminary data on a series of building comfort experiments conducted in the field. We performed physical in-situ measurements and solicited responses from university students in six different classrooms at the University of Massachusetts-Amherst during three seasons (fall, winter and spring). Our questions focused on the students' perception of comfort in varied environmental (temperature and humidity, and air speed) conditions. We collected records of the students' academic performance in the classes, correlating their comfort perceptions to their test scores. Statistical analysis of classroom environmental variables, thermal satisfaction, and student scores suggest that by enhancing thermal comfort, we can improve academic performance.

Keywords: thermal comfort, student performance, university classrooms, energy conservation

1 Introduction

The quality of the indoor environment (IEQ) impacts occupant productivity (Kim and de Dear, 2012). Occupant performance is correlated to healthy indoor air, as well as acoustic, thermal and visual comfort (Fisk and Rosenfeld, 1997, Shendell et al., 2004, Mumovic et al., 2009). Despite this, building engineers and managers design and operate buildings with the perspective that IEQ is maintained through a constant and uniform environment. Static models set fixed parameters for temperature, humidity, and air flow regardless of outdoor climate, occupant preference, and context. This approach leads to an increased reliance on mechanical controls and potentially energy intensive systems for thermal conditioning.

Good quality indoor environments depend on proper building design, operation, and maintenance. This directly influences building energy use. Poorly performing buildings are not only uncomfortable and energy intensive, they are also more expensive to operate. These impacts have an additional academic penalty when the building serves an educational purpose. Though numerous studies show that poor indoor air quality (IAQ) affects student performance (Bakó-Biró et al., 2012, Haverinen-Shaughnessy et al., 2011, Clements-Croome et al., 2008), air quality and ventilation rates are not the whole story (Corgnati et al., 2007, De Giuli, 2012). The hypothesis of this research is that student performance suffers when students feel discomfort and increasing thermal satisfaction in university classrooms should translate into improved academic achievement among students.

2 Background

Research on human thermal comfort began in 1970 (Fanger, 1970) and has been the basis for a number of comfort models and standards (ASHRAE, 2010) that drive the design and operation of indoor environmental systems. These models are based on the idea that despite different climates, living conditions, and cultures, the temperature that people find comfortable under similar conditions of clothing, activity, humidity, and air movement are remarkably equivocal (Fanger, 1972, de Dear and Leow, 1990, Busch, 1992). Quantifying the heat exchange between a body and the environment involves developing heat balance models, where independent environmental parameters (air temperature, mean radiant temperature, relative humidity, and relative air velocity) are measured in addition to independent personal variables such as metabolic activity and clothing.

Understanding occupants' needs is important for all actors involved in the building and operation process--from designers, engineers, and developers to facility managers. Research has demonstrated that the quality of the indoor environment has considerable impact on human health, stress, productivity and wellbeing (Fisk, 2000, Niemelä et al., 2002, Humphreys and Nicol, 2007, Loftness et al., 2007). This has largely been driven by the awareness that IEQ issues impact office-based workforces and sick building syndrome. Much of the existing scholarship is focused on quantifying the relationship between occupant comfort and thermal conditions (such as temperature and humidity), acoustic quality, air quality, and visual access, based on the adaptive comfort model. The adaptive comfort model, in contrast to heat balance models, suggests that comfort is a variable condition that is influenced by behavioral, physiological, and psychological processes (Fountain et al., 1996, Nicol and Humphreys, 2002). Adaptive models provide evidence that people naturally adapt or make adjustments to themselves and their surroundings to reduce discomfort.

There are a range of direct and indirect mechanisms that influence comfort, such as outdoor conditions, gender, age, clothing, activity schedules or levels, as well as control over air movement, ventilation, and local temperatures. However, little is known about whether and how much perceptions of comfort affect academic performance (Frontczak and Wargocki, 2011). (Lee et al., 2012) analyzes (thermal, indoor air, visual and acoustic) IEQ in air conditioned university classrooms in Hong Kong against self-reported learning performance where respondents used a percentage value that best described their own performance in four learning-related activities, calculating, reading, understanding and typing. (Bell et al., 2005) examines the relationship between clothing comfort and cognitive performance, where student test scores are compared against comfort ratings in a single class. While these studies suggest that there is a relationship between perceived comfort and academic achievement, there is little information available about how environmental parameters influence *both* sensations of thermal discomfort *and* student performance. The purpose of this research is to quantify the relationship between thermal comfort parameters (temperature, humidity, and air speed), the psychological comfort, and academic performance (test scores). There are no published examples of studies that take all three variables into account and this paper presents preliminary analysis of measurements from 409 students in six different classrooms during three different seasons.

3 Method

This study was conducted at University of Massachusetts-Amherst during a nine-month period between January-May (spring term) and September-December (fall term) 2013. It focuses on classroom teaching activities that are typically scheduled between 9:00 a.m. and 6:00 p.m. Monday to Friday. We solicited faculty who would be willing to participate and collected data on class meeting time, location, and nominal room capacity. Preliminary class capacity assessments were made to ensure our study population would contain a sufficient number of respondents.

3.1 Study Area

This analysis focuses on four different buildings (B-type) in three 60-seat seminar rooms (S-type) and three 80-seat lecture halls (L-type). Table 1 provides additional characteristics of the six different rooms that were analyzed. All data collection and surveys were conducted on weekdays during the class period (Monday–Friday, 10:30–3:30 p.m.) during the spring and fall terms.

Table 1. Characteristics of the classrooms

Classroom	#students /room capacity	Month of study	Windows	HVAC system	Operating during data collection
S-B1	55/58	November	Yes, open	Radiant ceiling	Yes
S-B2	60/64	December	Yes, closed	Forced Hot Air	Yes
S-B3	63/60	April	Yes, closed	Convactor	Yes
L-B1	77/80	March	Yes, closed	Radiant ceiling	Yes
L-B2	82/81	October	Yes, closed	Forced Hot Air	Yes
L-B3	72/80	February	No	Convactor	No

Air speed, temperature and humidity parameters were collected in each classroom using a Kestrel Meter 4500 at six different points in the volume over the class period and averaged. Outdoor measurements for temperature and humidity were also taken using a Kestrel 4500 weather meter. All instruments were calibrated according to the manufacturer's instructions prior to all measurements. The data are presented in Table 2.

Table 2. Environmental parameters in and around classrooms

Classroom	Outdoor temp (°F)	Indoor temp (°F)	Outdoor RH (%)	Indoor RH (%)	Indoor air speed (FPM)
S-B1	56	68	96%	75%	236
S-B2	10	72	89%	38%	100
S-B3	67	76	59%	43%	120
L-B1	30	80	41%	50%	100

L-B2	39	74	57%	28%	100
L-B3	20	70	86%	22%	100

3.2 Student Population

Cross-sectional data were collected from students ($N=409$) enrolled in six different undergraduate courses at the University of Massachusetts. The courses were all second or third year courses and we collected data about student gender and age. The mean age was 20.7 ($SD = 4.2$ years); 45% ($n=184$) were female. All of the procedures used in this study were conducted in accordance with principles and procedures for the protection of human subjects.

We measured the environmental parameters on the day the students took an exam as well collected data on thermal comfort perceptions from the students. The final three questions on the exam were questions pertinent to this study. Students were asked their gender, age, and to characterize their comfort level using the ASHRAE descriptive scale (Table 3). We did not collect data about ethnicity, clothing, or activity prior to class though these data may have had some influence on comfort perceptions. We decided instead to ask questions that would require very little time and effort, in order to minimize the data collection time (to not interfere with the exam). Every effort was made to keep interventions by the researchers to a minimum.

Table 3. Comfort Indicators using the ASHRAE scale

Answer	ASHRAE descriptor	Numerical equivalent
A	Hot	2
B	Warm	1
C	Neutral	0
D	Cool	-1
E	Cold	-2

3.3 Academic Performance Measurements

We obtained the student exam scores, which were calculated from 0 to 100, as well as their responses to our three study questions. Statistical methods were used to analyze the data to define the association between environmental parameters, comfort indicators, and test scores. The aim was to find the combination of thermal variables (temperature, humidity, and air speed) which the students consider ‘neutral’ or ‘comfortable’ and associate this with their test scores.

4. Results

4.1 Comfort perception and academic performance

Due to the inherently subjective nature of comfort, the first question of interest is whether there is a relationship between self-reported comfort and performance as measured by test scores. We converted the comfort scale (-2, cold; 0, neutral; +2, hot) using absolute values

to a discomfort scale (0, comfortable; 2, high thermal discomfort) to evaluate this question. The discomfort scale is useful because there is no consensus in the literature regarding the relative impact of feeling too hot or too cold. Also, as discussed below, we found only a very weak relationship between actual dry bulb temperature and individual self-reported perception of feeling cold or hot. Prior to analysis, checks of the assumptions of normality, linearity, and homoscedasticity were met. As evident in table 4, increased thermal discomfort is associated with lower test scores. Indeed, there is a statistically significant negative correlation between thermal discomfort and test scores $r(408) = -0.564, p < 0.001$. The negative correlation means that, in general, students who felt thermal discomfort performed worse on tests than those with no thermal discomfort. Following Cohen (1988) a correlation (r) of ± 0.5 should be considered to be large for a difficult to control area of research. In addition, the effect size ($\eta^2 = .338$) indicates that approximately 34% of the variance is accounted for by thermal discomfort. Given that one would expect most of the variance in test scores to be attributable to factors not measured in this study such as the difficulty of the material, whether students studied well, and the natural aptitude of the students, this effect size is remarkably large.

Table 4: Test score means, standard deviations, and sample size for three levels of thermal discomfort

Thermal Discomfort	Mean Test Score	N	Std. Deviation
no thermal discomfort	89.95	129	6.625
thermal discomfort moderate	85.09	198	7.486
thermal discomfort high	75.26	82	7.620
Total	84.65	409	8.891

As evident in the box plot in figure 1, however, there is a high degree of variability in test scores, such that thermal discomfort is not highly predictive of test score outcomes.

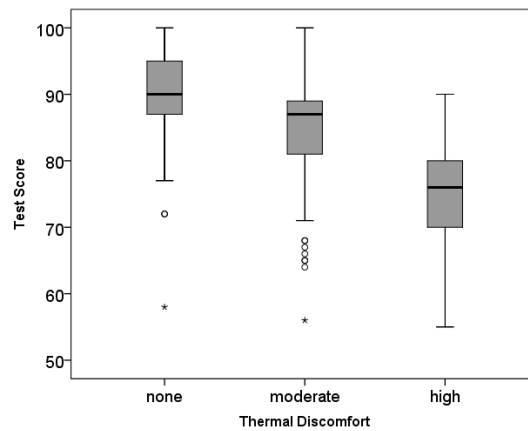

Figure 1. Plot of Thermal Discomfort against Test Scores

None of the other variables, including age, gender, class size, number of students, and environmental variables (such as temperature and humidity) were correlated to, or showed any significant mean difference in test scores. Thus, in general, roughly a third of the variability in test scores is explained, not by the typically expected social and academic variables, but by the student’s perceived thermal discomfort.

4.2 Factors influencing comfort perception

In the above analysis, we used the absolute value of the participant’s comfort rating in part because of the weak relationship between measured dry bulb temperature and reported thermal perception. Comfort on a scale from “too cold” = -2 to “too hot” = +2 is weakly correlated to indoor measured temperature, $r(408)=0.122$, $p=0.014$. Most likely, some other combination of factors would help to better explain thermal comfort ratings. Factors we considered included how crowded a room might feel, radiant asymmetry, gender, and age. The crowding variable was calculated as a ratio of room population to room capacity. Radiant asymmetry was calculated as the ratio of the lowest and highest surface temperatures in the room. For radiant ceilings, the mean surface temperature was assumed to be 10°F above the mean room air temperature. Floors were assumed to be 2°F below room air temperature. Interior walls were assumed to match mean air temperature. To calculate exterior window and wall temperatures, we used known R-values for the specific building elements in question and indoor and outdoor air temperatures to calculate surface air temperatures using the following equation.

$$T_s = \frac{(T_{in} - T_{out})}{(T_{in})} \times \frac{R_{af}}{R_{asbl}}$$

Where

T_s = temperature of the inside surface

T_{in} = inside air temperature

T_{out} = outside air temperature

R_{af} = R value of the inside air film

R_{asbl} = R value of the wall or window assembly

As shown in table 5, none of these variables are strongly correlated to comfort. Despite small correlation coefficients (r), and thus small effect sizes, the correlations are significant and worth exploring. We hypothesized that a linear hierarchical regression model could be constructed, such that these variables together explain variability in thermal comfort better than any single variable separately.

Table 5. Mean, Standard Deviations, and Correlation Coefficients among variables

Variable	Mean	SD	1	2	3
1. Comfort	.17	1.122			
2. Gender	.46	.499	-.251**		

3. Radiant Asymmetry	.581	.282	-.142**	-.002	
4. Room Fill	.953	.062	-.175**	.019	.261**

None of the variables were correlated above 0.3, suggesting an absence of multicollinearity. Prior to analysis checks of the theoretical assumptions underlying multiple regression were undertaken, including normality, linearity, and homoscedasticity. The assumptions were met, and a hierarchical regression analysis controlling for gender was undertaken. Each variable was entered as a separate step to assess the impact of each variable on the strength of the model (table 6).

Table 6. Hierarchical Regression Predicting Thermal Comfort Rating

Variables		Total Sample (N=409)		
		β	Tolerances	VIF
Step 1.				
Gender	$F(1, 407) = 27.334$ $R^2 = 0.063$	-.251**	1	1
Step 2.				
Control				
Gender		-.248**	1	1
Predictor				
Room Filled	$F(2, 406) = 20.560$ $R^2 = 0.092$ $\Delta R^2 = 0.029$	-.170**	1	1
Step 3.				
Control				
Gender		-.248**	1	1
Room Filled		-.143**	.932	1.073
Predictor				
Radiant Asymmetry	$F(3, 405) = 15.393$ $R^2 = 0.102$ $\Delta R^2 = 0.010$	-.106*	.932	1.073

Note β = Standardized beta coefficients, VIF = Variance Inflation Factors
* $p < 0.05$, ** $p < 0.001$

This combination of variables significantly predicted comfort rating, with all three variables significantly contributing to the prediction. However, it should be noted that of the three, gender contributes the most, with females being slightly more likely than males to report feeling cold. Even so, the R^2 value was only 0.1, suggesting that the model only explains 10% of the variance. This is a fairly small effect. Iterative model construction demonstrated that this combination of variables resulted in the highest R^2 value, besides being supportable theoretically.

5 Discussion

The research design of this study attempts to associate thermal satisfaction and student scores and it suggests that by enhancing thermal comfort, we can improve academic performance. If high thermal discomfort is a factor in decreased academic performance (as measured by test scores), then the practical implication is to increase the emphasis in providing increased thermal comfort in academic, office and other buildings where occupant performance is highly valued. However, because thermal perception is apparently difficult to predict using environmental variables, this study offers little guidance for assuring thermal comfort. This creates a greater challenge for facilities management staff who are responsible for maintaining building temperature and humidity set points. It also complicates building HVAC systems design and sizing strategies because it suggests that we know less about how to quantify comfort in high occupancy buildings. The lack of association between environmental variables and thermal comfort perception – and the small effect size of associated variables—suggest that a large variety of factors may lead to varying of different perceptions of comfort. Though not demonstrated by this study, it seems likely that the same individual may experience a wide range of thermal comfort responses to the same environmental stimuli at different times and in different emotional or social contexts.

An alternate conclusion of this study is that student reports of thermal discomfort reflect their own feelings of anxiety or frustration at doing poorly on an exam or anticipating a difficult exam. If emotional states are important factors in determining whether a person feels thermal discomfort, then there are implications for understanding how people interact with tools for controlling their thermal environment, like thermostats and window operation.

The results of this exploratory study are exploratory and associational, and thus it is impossible to determine causation. A future research design would involve controlled experimental conditions. These would include providing identical educational content to research subjects, controlling the air temperature, humidity, air speed and surface temperatures (this study used existing conditions not controlled by the researchers). This would allow not only control and test groups (for between group effects), but also control of temperature extremes (the temperatures in this study were warmer than may be typical, and had no examples of atypically cool temperatures). Other environmental variables that could be manipulated in future studies include ventilation rates and light color temperatures, as these factors may also contribute to perceptions of thermal comfort.

References

ASHRAE 2010. Standard 55 Thermal Environmental Conditions for Human Occupancy.
In: ASHRAE (ed.). Atlanta: American Society of Heating Ventilating and Air Conditioning Engineers.

- BAKÓ-BIRÓ, Z., CLEMENTS-CROOME, D. J., KOCHHAR, N., AWBI, H. B. & WILLIAMS, M. J. 2012. Ventilation rates in schools and pupils' performance. *Building and Environment*, 48, 215-223.
- BELL, R., CARDELLO, A. V. & SCHUTZ, H. G. 2005. Relationship Between Perceived Clothing Comfort and Exam Performance. *Family and Consumer Sciences Research Journal*, 33, 308-320.
- BUSCH, J. F. 1992. A tale of two populations: thermal comfort in air-conditioned and naturally ventilated offices in Thailand. *Energy and Buildings*, 18, 235-249.
- CLEMENTS-CROOME, D. J., AWBI, H. B., BAKÓ-BIRÓ, Z., KOCHHAR, N. & WILLIAMS, M. 2008. Ventilation rates in schools. *Building and Environment*, 43, 362-367.
- COHEN, J. 1988. *Statistical Power Analysis for the Behavioral Sciences*, Lawrence Erlbaum Associates.
- CORGNATI, S. P., FILIPPI, M. & VIAZZO, S. 2007. Perception of the thermal environment in high school and university classrooms: Subjective preferences and thermal comfort. *Building and Environment*, 42, 951-959.
- DE DEAR, R. J. & LEOW, K. G. 1990. Indoor climate and thermal comfort in high-rise public housing in an equatorial climate: A field-study in Singapore. *Atmospheric Environment. Part B. Urban Atmosphere*, 24, 313-320.
- DE GIULI, V. D. P. O. D. C. M. 2012. Indoor environmental quality and pupil perception in Italian primary schools. *Building and Environment*, 56, 335-345.
- FANGER, P. O. 1970. *Thermal comfort analysis and applications in environmental engineering*, New York, McGraw-Hill.
- FANGER, P. O. 1972. *Thermal Comfort*, New York, McGraw-Hill.
- FISK, W. J. 2000. Health and Productivity Gains from Better Indoor Environments and their Relationship with Building Energy Efficiency *Annual Review of Energy and the Environment*, 25, 537-566.
- FISK, W. J. & ROSENFELD, A. H. 1997. Estimates of Improved Productivity and Health from Better Indoor Environments. *Indoor Air*, 7, 158-172.
- FOUNTAIN, M., BRAGER, G. & DE DEAR, R. 1996. Expectations of indoor climate control. *Energy and Buildings*, 24, 179-182.
- FRONTCZAK, M. & WARGOCKI, P. 2011. Literature survey on how different factors influence human comfort in indoor environments. *Building and Environment*, 46, 922-937.
- HAVERINEN-SHAUGHNESSY, U., MOSCHANDREAS, D. J. & SHAUGHNESSY, R. J. 2011. Association between substandard classroom ventilation rates and students' academic achievement. *Indoor Air*, 21, 121-131.
- HUMPHREYS, M. A. & NICOL, J. F. 2007. Self-Assessed Productivity and the Office Environment: Monthly Surveys in Five European Countries. *ASHRAE Transactions*, 113, 606-616.

- KIM, J. & DE DEAR, R. 2012. Nonlinear relationships between individual IEQ factors and overall workspace satisfaction. *Building and Environment*, 49, 33-40.
- LEE, M. C., MUI, K. W., WONG, L. T., CHAN, W. Y., LEE, E. W. M. & CHEUNG, C. T. 2012. Student learning performance and indoor environmental quality (IEQ) in air-conditioned university teaching rooms. *Building and Environment*, 49, 238-244.
- LOFTNESS, V., HAKKINEN, B., ADAN, O. & NEVALAINEN, A. 2007. Elements That Contribute to Healthy Building Design. *Environmental Health Perspectives*, 115, 965–970.
- MUMOVIC, D., PALMER, J., DAVIES, M., ORME, M., RIDLEY, I., ORESZCZYN, T., JUDD, C., CRITCHLOW, R., MEDINA, H. A., PILMOOR, G., PEARSON, C. & WAY, P. 2009. Winter indoor air quality, thermal comfort and acoustic performance of newly built secondary schools in England. *Building and Environment*, 44, 1466-1477.
- NICOL, J. F. & HUMPHREYS, M. A. 2002. Adaptive thermal comfort and sustainable thermal standards for buildings. *Energy and Buildings*, 34, 563-572.
- NIEMELÄ, R., HANNULA, M., RAUTIO, S., REIJULA, K. & RAILIO, J. 2002. The effect of air temperature on labour productivity in call centres—a case study. *Energy and Buildings*, 34, 759-764.
- SHENDELL, D. G., PRILL, R., FISK, W. J., APTE, M. G., BLAKE, D. & FAULKNER, D. 2004. Associations between classroom CO₂ concentrations and student attendance in Washington and Idaho. *Indoor Air*, 14, 333-341.

Thermal Comfort during daily prayer times in an Air-Conditioned Mosque in Malaysia

A. Hussin, E. Salleh*, H.Y. Chan and S. Mat

Solar Energy Research Institute, Universiti Kebangsaan Malaysia,
43600 UKM, Bangi, Selangor, Malaysia.

* Corresponding author. Tel: +6019-4503145, Email: elsall06@gmail.com

Abstract

This study evaluated the thermal environment in an air-conditioned mosque in Malaysia during the various daily prayer times. The objectives of the study includes determining the clo values, the neutral operative temperature, comfort temperature, and assessing the reliability of the PMV model predictions in determining thermal comfort in these situations. A field study was conducted in November 2012 and April 2013 during *Subuh*, *Zohor*, *Asar*, *Maghrib* and *Isyak* prayer times. Results show that PMV model predictions and AMV were found to be 25.88 °C and 30.44 °C, respectively. The difference of 4.56 °C between PMV and AMV indicates that thermal comfort under these conditions cannot co-relate well with ASHRAE Standard-55. A new range of thermal comfort temperature between 26.99 °C to 31.41 °C was derived. Overall observations found that worshippers' thermal comfort in the hot and humid climate such as Malaysia favours the adaptive approach.

Key words: Mosque, prayer times, Predicted Mean Vote, Actual Mean Vote, Adaptive approach

1. Introduction

With the rapid growth of mosque building and its functions in the Muslim community in Malaysia, a provision for thermal comfort of worshippers is a prime concern. Inappropriate thermal comfort in mosque buildings leads to unsuitable thermal environment for the worshippers and the functions held inside. It has become common practice that mosques in Malaysia are installed with air-conditioning (A/C) systems to provide cooling and better thermal comfort to the worshippers. However, there is a lack of information on the actual indoor climatic as well as thermal comfort conditions in Malaysian mosques so far. The increasing trend of A/C use in Malaysian mosque buildings is apparently increasing electricity consumptions in the daily mosque operations.

In order to evaluate the thermal comfort in an A/C building, Predicted Mean Vote (PMV) and Predicted Percent Dissatisfied (PPD) are the common thermal comfort indices that have been used worldwide. The international standard such as ASHRAE Standard-55, (2013) and ISO 7730, (2005) have defined the approach to thermal comfort evaluation in terms of PMV and PPD. Many studies have been conducted to investigate the indoor thermal comfort in buildings using the PMV and PPD approach such as:- Orasa & Oliveira, (2011) on office, Al-ajmi, (2010) ; Al-homoud et al., (2009) on mosque, Kwok & Chun, (2003) on school, Azizpour et al., (2013) on hospital and others. On the other hand, evaluation of thermal comfort using the adaptive model also has been introduced. This approach has been particularly promoted by Nicol and Humphreys whereby they have found strong correlation

between indoor and outdoor conditions with occupants adaptation behaviour (Nicol, 2004 ; Nicol & Humphreys, 2002).

1.1 Malaysian Climate and Mosque Religious Practices

Malaysia is located within the Latitude and Longitude of 1° - 7° North and 100° - 119° East, respectively. The daily ambient air temperature is about 24 °C to 38 °C, whilst relative humidity ranges between 70 % to 90 % through the year, with relatively low air movements. These climatic conditions basically result in a high thermal environment in building indoor spaces.

Malaysia has a majority of Muslim population, whose religious practices such as daily prayers, preaching and citation of the Al-Quran are held in the main prayer hall (MPH) of mosque buildings.

The communal daily prayer is performed five times a day (*Subuh, Zohor, Asar, Maghrib* and *Isyak* prayers) starting from early morning until night time with duration of about thirty minutes to an hour each to complete. Each of the prayers will be performed in a group, led by an *Imam* with the worshippers standing, bowing, prostrating or sitting behind the *Imam* aligned in *safs*. Table 1 summarises the meanings of terminologies used in this study.

Table 1: Religious terminologies

Malay	Arabic	English
<i>Subuh</i>	<i>Fajr</i>	Dawn
<i>Zohor</i>	<i>Zohar</i>	Early afternoon
<i>Asar</i>	<i>Asr</i>	Late afternoon
<i>Maghrib</i>	<i>Maghrib</i>	Sunset
<i>Isyak</i>	<i>Isha</i>	Night
<i>Terawikh</i>	<i>Tarawikh</i>	Special Ramadhan night prayer after <i>Isyak</i>
<i>Imam</i>	<i>Imam</i>	Person leading a prayer
<i>Baris</i>	<i>Safs</i>	Rows
<i>Aurat</i>	<i>Aura'</i>	Parts of human body forbidden to be exposed to view: Male – between the navel and the knee Female- the whole body except for the face and palms
<i>Qariah</i>	<i>Qaryah</i>	Community living nearby/neighbourhood sharing the mosque
<i>Mehrab</i>	<i>Mihrab</i>	A niche in the wall of a mosque that indicates the direction of Mecca
<i>Mimbar</i>	<i>Minber</i>	A pulpit in the mosque where the imam stands to deliver sermons
<i>Qiblat</i>	<i>Qibla'</i>	Prayer direction to the holy city of Mecca

This study aims to evaluate the thermal environment in an A/C mosque during the various daily prayer times. The objectives of the study include (i) Determining the clo-values of worshippers during prayer times, (ii) Determining the neutral operative temperature and comfort temperature from worshippers' thermal responses; and (iii) Assessing the reliability of the PMV model predictions in determining thermal comfort in A/C mosque building.

2. Field study

Thermal comfort is evaluated in MPH of one air conditioned mosque building (Mosque A/C) for daily prayer mode. The selected Mosque A/C is located at Latitude 5.5170 °North and Longitude 100.2600 °East, Kepala Batas Penang Malaysia. Overall, a total number of 44 mosque buildings are located around Kepala Batas town, Penang Malaysia. Whilst it is

impossible to cover all mosque building types, the following criteria have been considered for the choice of mosque for this study:

- Construction of not more than 10 years old
- Of reasonable size (<1000 worshippers')
- Modern design and using modern construction materials
- Building with dome
- Using mechanical system such as air conditioning

Measurement data were recorded on 25-27 November 2012 and 14-16 April 2013 representing the local cooler and the hotter seasons, respectively. Worshippers' thermal comfort and sensations were evaluated and observed during the daily prayer time modes of *Subuh*, *Zohor*, *Asar*, *Maghrib* and *Isyak*. These involved collection of environmental indoor measurement and questionnaires among worshippers'. Outdoor thermal environmental data from nearby Butterworth weather station of the Meteorological Department of Malaysia were obtained for the measurement dates.

2.1 Mosque building as a case study

The selected sample of Mosque A/C (known as *Masjid AT-Taqwa*) is one of the *qariah* (community) mosques (Figure 1). The mosque was built in year 2004 and was constructed based on a square plan. The total built-up area of the MPH is 640.1 m² and the wall height is 6 metres. The West-facing wall is oriented towards the direction of holy city, Mecca and contains the *mehrab* where the *Imam* is located during prayers. Adjacent to the *mihrab* is the *mimbar*, located at the right side and elevated 1.5 metres above the floor, where the *Imam* delivers the Friday sermon (*Khutba*). The walls facing Northward and Southward are built with two sliding doors for entrance and six windows on each side. The wall facing Eastward, is built with four sliding doors for entrance and also with three windows on each side. The door dimension is 1.83m x 2.2m each. Windows have a frame dimension of 2.2m x 1.6m and built in with four sliding leaves. All the windows are installed for ventilation purposes. The mosque has a roof that is constructed together with one big dome, located at the center of the MPH. The MPH can be occupied by approximately 800 worshippers' at any one time. The floor area is finished with carpet that has a built-in pattern for the *safs*, parallel to the *qibla* wall (Westward). The distance between each *saf* is about 1.06 metres. The mosque had been installed with 12 units of split air-conditioning system (capacity is approximately 32 horse power) and supported by 15 units of wall fans. All the appliances are wall-mounted to distribute cooled air into the MPH area (Figure 1). The control temperature of the air-conditioning units were set at 21 °C and indoor fans were running at maximum speed. During the operation of the mechanicals system, all windows were fully closed with occasional opening of the doors.



Dome and roof

Minaret

a) Building view from West



Mehrab & Mimbar

Safs pattern

b) View of *Mehrab* and *Mimbar*



Doors

Windows

c) Internal view of South-facing wall



Wall fan

Split air-cond

d) View of wall-mounted A/C unit and fans

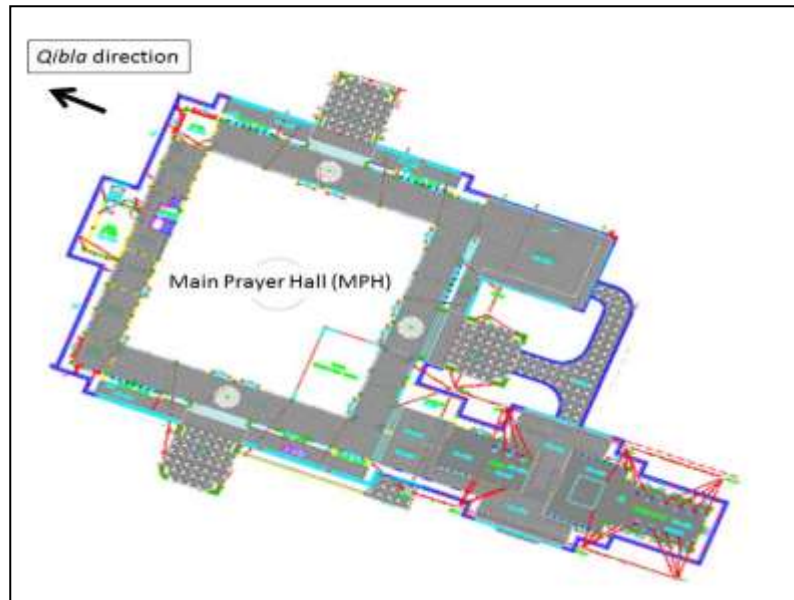

e) Main prayer hall (MPH) layout plan

Figure 1 Plan of Mosque A/C

Note: a) Building view from West, b) View of *Mehrab* and *Mimbar*, c) internal view of South-facing wall, d) View of wall-mounted A/C unit and fans, and e) MPH layout plan

2.2 Questionnaire survey

The survey questionnaire consists of three sections: (a) demographic background, (b) clothing, (c) current thermal comfort. The questionnaire was developed and adopted from previous study (Al-ajmi, 2010) where worshipper can feel free to evaluate their thermal environment in MPH of Mosque A/C. In addition, the clothes types was also obtained from the survey and cloth value (clo) was estimated based on clothes assemblies references in ISO 7730 (2005). ASHRAE seven point thermal sensation scale (+3 to -3) was included in questionnaire, to assess the Actual Mean Vote (AMV) or Thermal Sensation Vote (TSV) reflecting the qualitative thermal sensation of worshippers. To compare the results of the survey (AMV) with those of the PMV model predictions, statistical methods were carried out using SPSS software version 20.0 (SPSS, 2012). The control point is based on ASHRAE acceptable thermal environment for general comfort where $PPD < 10\%$ or $(-0.5 < PMV < +0.5)$ ASHRAE Standard-55, (2013).

2.3 Objective measurement

Measurements of indoor microclimatic conditions were made with a portable meteorological climatic assembly known as 'Multi Station Thermal Comfort Real Time Monitoring System' (MSTCRTMS). The MSTCRTMS station includes sensors for the measurement of dry-bulb air temperature (T_a ; °C), globe temperature (T_g ; °C) wind speed/air velocity (V ; m/s) and relative humidity (RH; %). Air velocity, air temperature and relative humidity were measured using function probe of KIMO CTV100-ANA300. Globe temperature was measured using a globe thermometer. All measurements were connected to ADAM View Software Version 4.30.004, the thermal data logging system. The equipment set-up have been tested and calibrated before starting the measurements. The MSTCRTMS station was installed at a height of 1.1 m above from floor level and located at fixed position in main prayer hall (between *saf* 6 & 7). The height level proposed by ASHRAE Standard-55, (2013) for light activity-standing/sitting, is almost suitable condition to worshippers during performance of the daily prayers. The metabolic rate value used in this study was estimated to be 1.3 met as recommended by previous research (Al-ajmi, 2010), for near sedentary physical activity. PMV and PPD values were determined using software CBE Thermal comfort tools for ASHRAE Standard-55 (Hoyt et al., 2012).

3. Results

3.1 Demographic information

Table 2 shows the worshippers' demographic information which included the worshippers' categories and ages. The number of respondents was 396 people and all of them were male. They included 6.3 % from mosque officers, 41.8 % from *qariah* (close community) and 51.9 % from others (non *qariah* members, visitors and travellers). Their ages range from 18-30 (22.73 %), 31-40 (10.61 %), 41-50 (42.42 %), 51-60 (21.21 %) to over 61 (3.03 %).

Figure 2 illustrates the MPH of Mosque A/C, the MSTCRTMS position, the worshippers' with their attires during performance of their prayer and the evaluation of thermal comfort among worshippers'. Physical data for daily prayers was recorded starting at 2.30 am and lasting till 10.30 pm, synchronized with Malaysian standard time.

Table 2: Demographic information

Mosque A/C	Daily prayers (n=6 days)					Mean all
	Subuh	Zohor	Asar	Maghrib	Isyak	
<i>Sample size</i>	66	66	66	66	66	%
<i>Worshipper</i>						
Mosque officers	6	2	9	0	3	6.30
Qariah members	31	22	27	31	27	41.80
Others	29	42	30	35	36	51.90
<i>Age</i>						
18-30	16	10	16	19	15	22.73
31-40	9	17	10	15	7	10.61
41-50	16	22	19	24	28	42.42
51-60	17	13	16	6	14	21.21
61 above	8	4	5	2	2	3.03



a) Thermal comfort station in MPH



b) Daily prayer mode



c) Questionnaires

Figure 2: Measurement activities at Mosque A/C on 25-27 November 2012 and 14-16 April 2013

3.2 Clo value

Table 3 shows the common clothes worn by the worshippers' during performance of daily prayers at Mosque A/C including the clo values. The most common clothes indicated is traditional Malay long sleeves shirt paired with *kain sarung* (59.1 %) during *Subuh* prayer, while 43.9 % and 40.9 % during *Maghrib* and *Isyak* prayers. At noon (*Zohor* prayer), most of the respondents were working employees and they wore the normal working attire of long sleeve shirts paired with normal trousers. Thus, during *Zohor* prayer, 24.2 % of respondents wore these clothes compared to traditional Malay clothes (19.7 %). The highest clo values indicated as in Table 4 is during *Zohor* prayer (0.581), followed by *Subuh* prayer (0.536), *Maghrib* prayer (0.516), *Isyak* prayer (0.512) and *Asar* prayer (0.495). This clo value was then used for PMV calculation.

Figure 3 shows that there is no correlation ($R^2 = 0.005$) between worshippers' clothing and Operative Temperature when they attended Mosque A/C. There are several factors involved regarding this situation. Firstly, the climatic condition which is hot and humid throughout the year, and secondly, the requirement of Muslim's attire when performing the prayer. In Islam, there is no limitation to the type of attire when visiting the Mosque for performing the prayers except that it must cover the basic *aurat* (men: from knee to navel; women: the whole body except the face and the two palms) and be clean from dirt. Thirdly, due to the strategic location of the mosque (close proximity to houses), the Malay traditional attire such as traditional Malay long sleeves shirt paired with *kain sarung* were the most common attire worn by the worshippers especially for *Subuh*, *Maghrib* and *Isyak* prayers. The same situation was reported by Al-ajmi et al., (2006) in Arab counties where it was found that the worshippers wore customary attire during prayers at the mosque.

Table 3: Common clothes wearing by worshippers' during daily prayer

Type of clothes	Clothes percentages				
	<i>Subuh</i>	<i>Zohor</i>	<i>Asar</i>	<i>Maghrib</i>	<i>Isyak</i>
Traditional Malaysia long sleeves shirt with trousers	9.1	18.2	27.3	27.3	25.8
Traditional Malaysia long sleeves shirt with <i>kain sarung</i>	59.1	19.7	31.8	43.9	40.9
Traditional Malaysia long sleeves shirt with normal trousers	9.1	3	7.6	3	13.6
Traditional Malaysia long sleeves shirt, with jeans	1.5	0	0	0	0
Normal shirt with <i>kain sarung</i>	3	16.7	4.6	4.6	1.5
Normal shirt with normal slack	0	0	3	1.5	0
Normal shirt with jeans	0	0	1.5	0	1.5
Arabic clothes (<i>Jubah</i>) with <i>kain sarung</i>	15.2	1.5	3	9.1	6.1
Arabic clothes (<i>Jubah</i>) with normal trousers	3	3	1.5	0	6.1
Arabic clothes (<i>Jubah</i>) with athletic sweat pants	0	4.5	1.5	4.5	0
Long sleeves shirt with normal trousers	0	24.2	13.6	3	1.5
Long sleeves shirt with jeans	0	6.1	1.5	0	0
Long sleeves shirt with <i>kain sarung</i>	0	3	3	3	3

Table 4: Clo value by worshippers' during daily prayer

Clo-value	<i>Subuh</i>	<i>Zohor</i>	<i>Asar</i>	<i>Maghrib</i>	<i>Isyak</i>
Mean	0.536	0.581	0.495	0.516	0.512
S.D	0.147	0.191	0.100	0.139	0.128
Min	0.420	0.420	0.420	0.420	0.420
Max	0.860	0.890	0.890	0.890	0.860

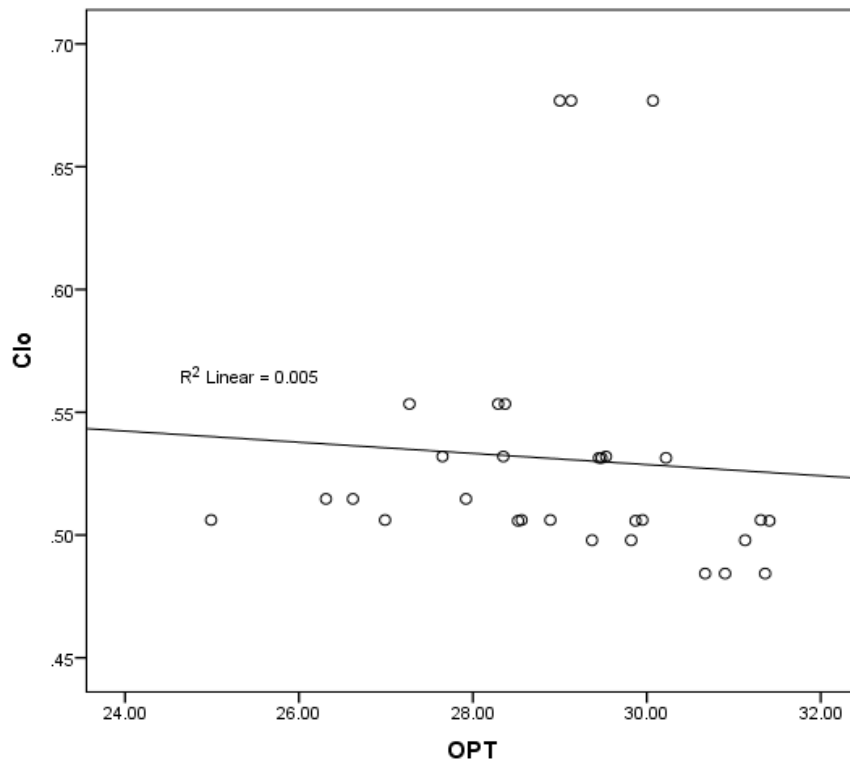

Figure 3: Clo value and relation to Operative Temperature (OPT)

3.3 Indoor climatic conditions

Figure 4 shows the daily pattern of the average indoor climatic conditions in Mosque A/C starting from 2.30 am till 10.30 pm daily. The observed periods were *Subuh*, *Zohor*, *Asar*, *Maghrib* and *Isyak* prayers. It is observed that indoor ambient temperature (T_a) and air velocity movement (V) in MPH have unique patterns when the air conditioning system and fans were operated. T_a was generally reduced meanwhile the air flow increased during these prayer times. The same observation can be made for relative humidity (RH) where small percentage was reduced in all daily prayer times. After worshippers completed each prayer mode, the air conditioning system and fans were switched off. Thus, the indoor T_a and RH increased again slightly and the air flow decreased.

Mean Radiant Temperature (MRT) and Operative Temperature (OPT) were having higher values in early morning period of 2.30 -5.30 am, and subsequently at 7.10-13.00pm, 14.30-16.10 pm, 17.30 -18.50 pm and 21.10-22.30 pm. One explanation is that during these times all openings were closed and all fans and A/C system were not operating, resulting in warmer

indoor conditions and surfaces. When prayer time starts, the MRT and OPT decreased slightly due to the cooling process produced from the operation of A/C systems and fans.

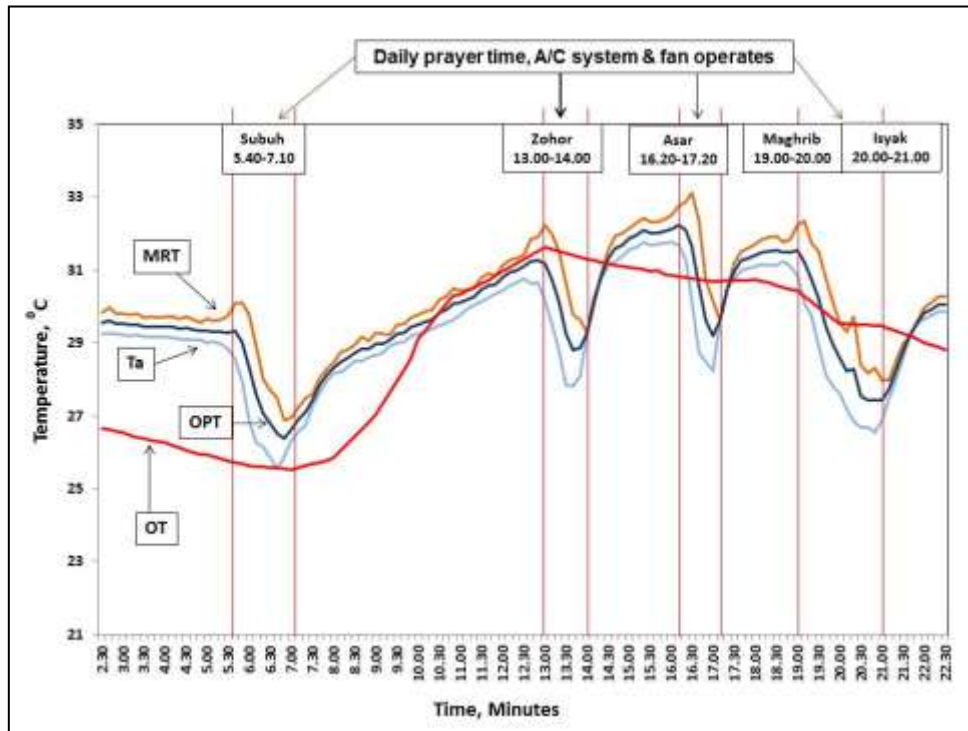

a) Indoor Temperature (Ta), Mean Radiant (MRT) and Operative Temperature (OPT)

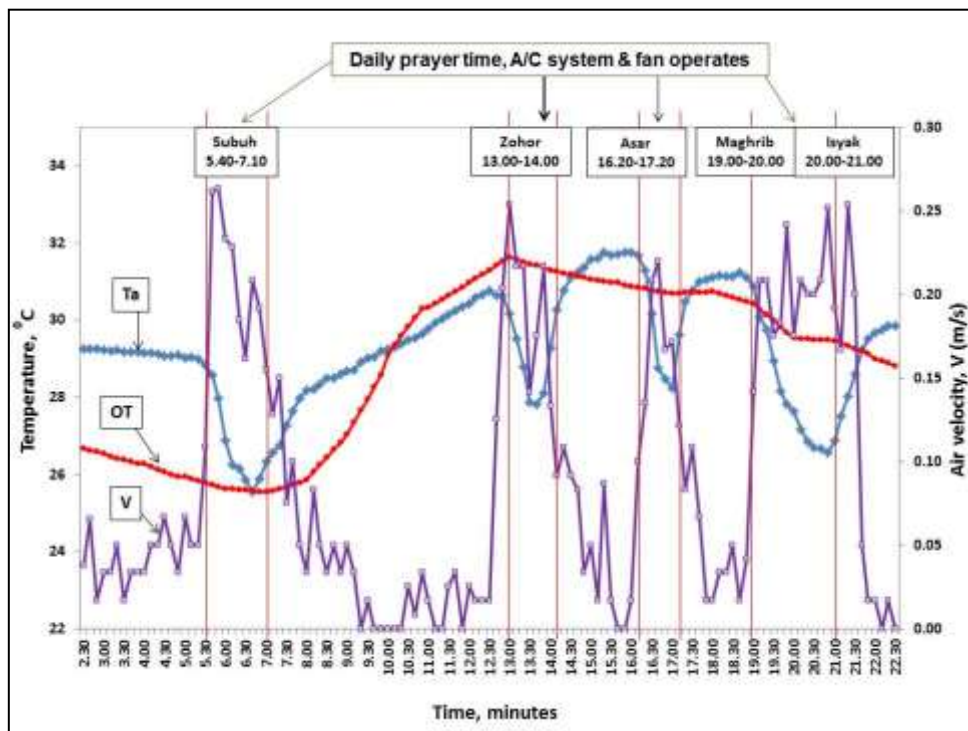

b) Indoor Temperature (Ta) VS Air velocity (V)

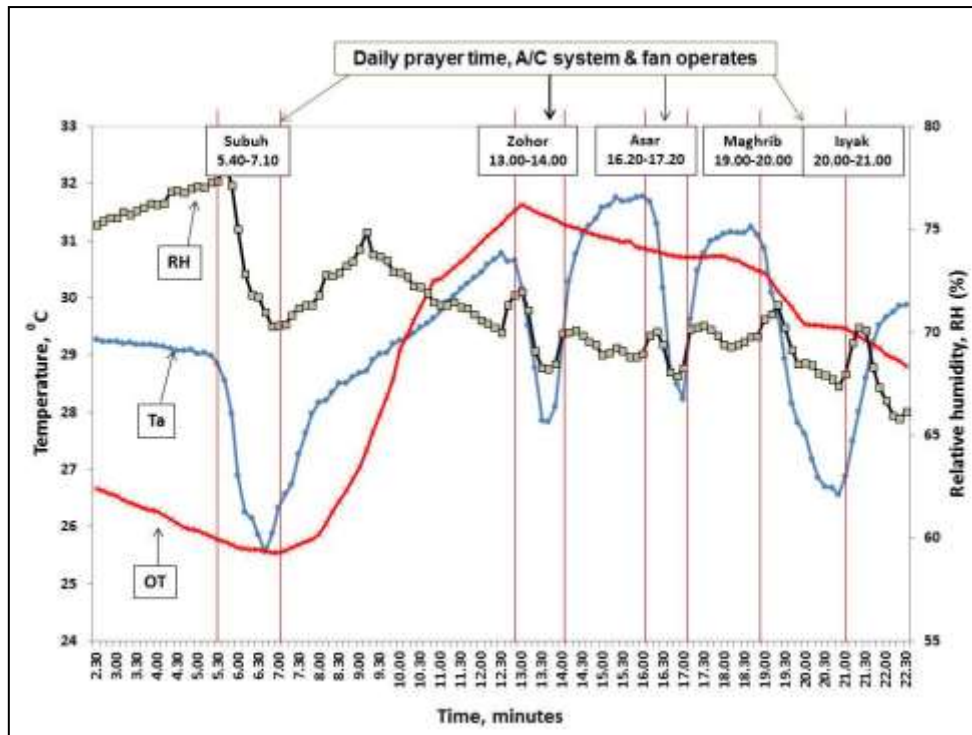

c) Indoor Temperature (Ta) VS Relative Humidity (RH)

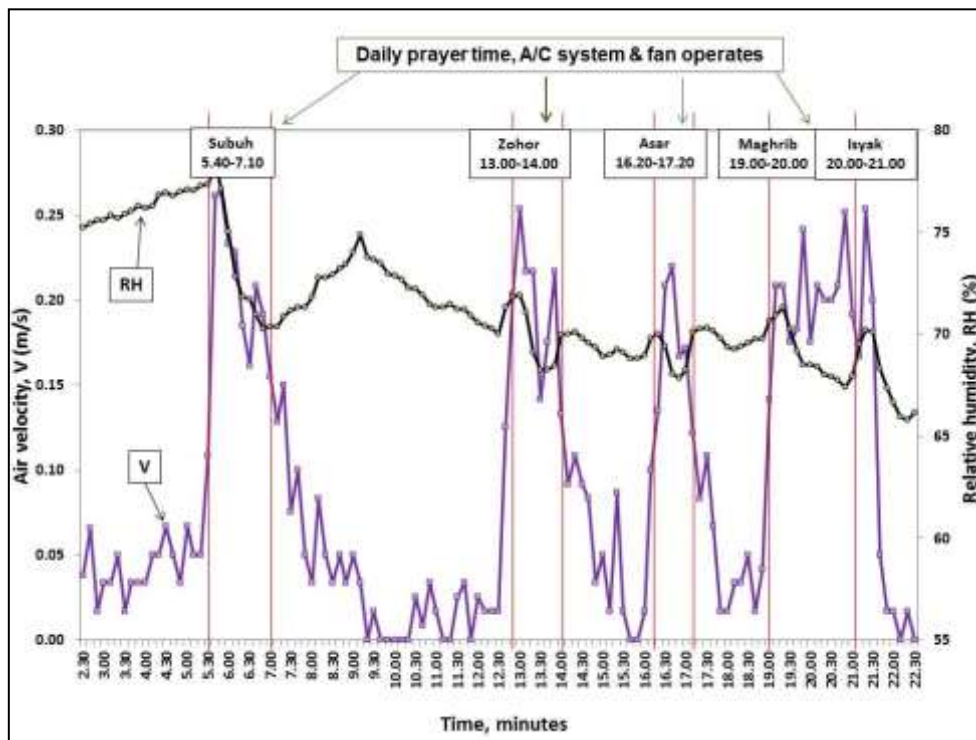

d) Air velocity (V) VS Relative Humidity (RH)

Figure 4: Indoor climates in Mosque A/C

Note: Ta = Indoor Temperature; MRT = Mean Radiant Temperature; OPT = Operative Temperature; OT = Outdoor Temperature; V = Air Velocity; RH = Relative Humidity

3.4 Worshippers' thermal sensation

Figure 5 shows the result of thermal response based on ASHRAE seven-point thermal sensation scale (ASHRAE Standard-55, 2013). Most of the votes for *Subuh*, *Zohor* and *Maghrib* prayer times indicate cool thermal sensations, which reflects that the worshippers felt cool with their environment instead of normal. Only *Asar* and *Isyak* prayers contain a normal curve distribution which indicates that worshippers felt normal with the thermal environment. At observation times, OPT temperature range were from 26.38-29.33 °C (*Subuh*), 28.81-31.20 °C (*Zohor*), 29.2-32.1 °C (*Asar*), 28.6-31.5 °C (*Maghrib*), 27.4-28.6 °C (*Isyak*), respectively. There is a variance of vote for *Isyak* prayer where the OPT temperature was slightly low but the vote was normal when compared to *Maghrib* prayer. The explanation to this is the length of stay in MPH by worshippers' who remained in the MPH after completing their *Maghrib* prayer. During this times, they had a short religious lecture which was delivered by the *Imam*. Sometimes, they would continue praying individually or quietly recite Al-Quran until the *Isyak* prayer time. This practice was common and therefore resulted in a longer period of stay in the mosque (say 2 hrs.) for these worshippers. Even though the indoor OPT temperature was slightly higher, the thermal sensation votes shows that the majority of worshippers accepted their thermal environment (Figure 5). One possible explanation is due to the longer staying period in the mosque (2 hrs.) resulting in body adjustment and adaptation behaviour among worshippers. The prior exposure to the external hot and humid conditions gave the benefits to worshippers to prepare and try to tolerate the cooler indoor conditions. The same situation was reported by Kwok & Chun, (2003) in school buildings where past experience or knowing the indoor thermal condition will give the student the chance to prepare themselves before being exposed to the conditions.

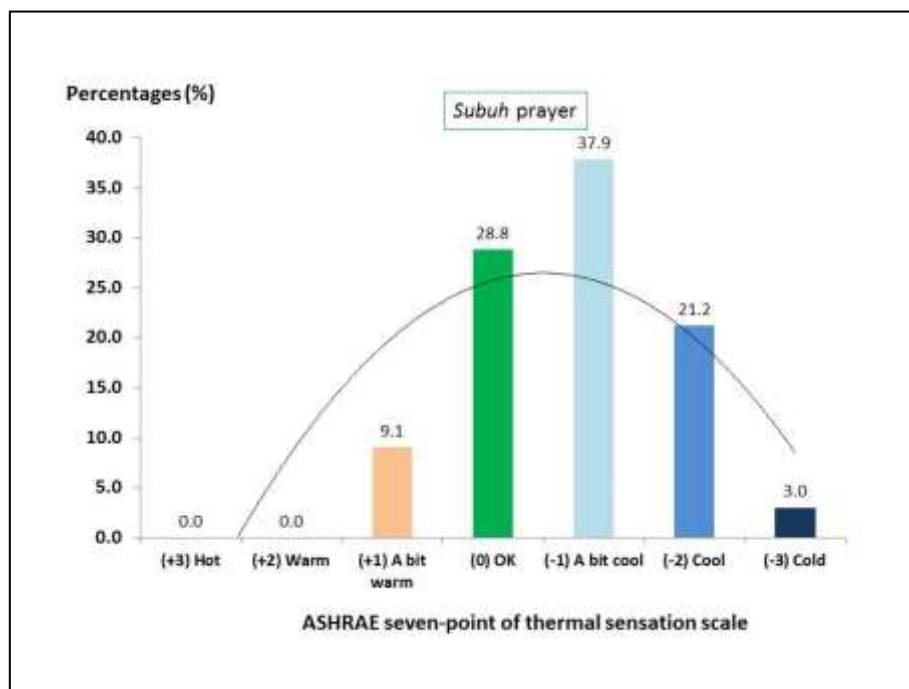

a) *Subuh* prayer

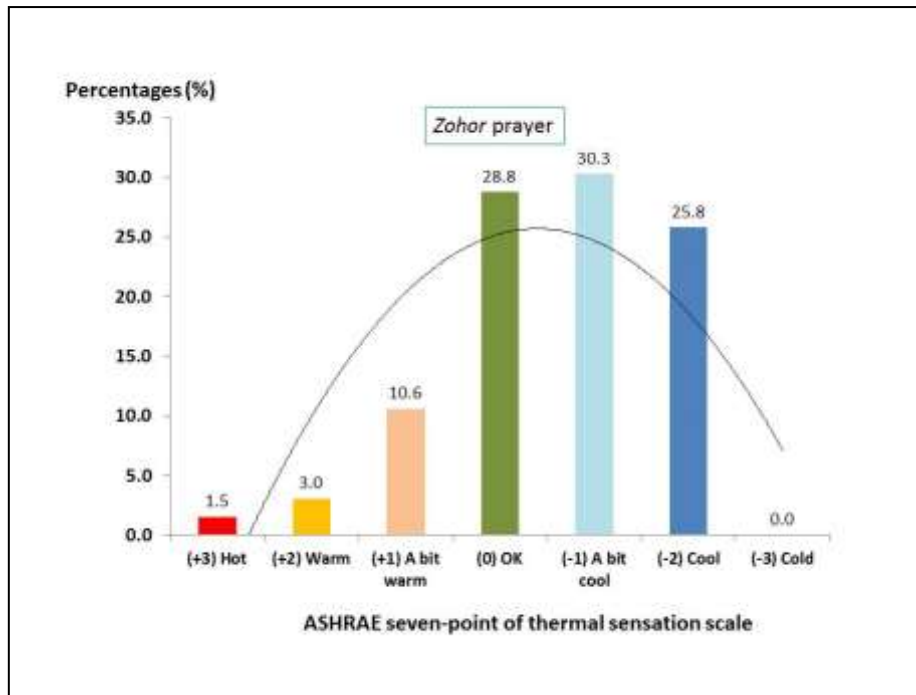

b) *Zohor* prayer

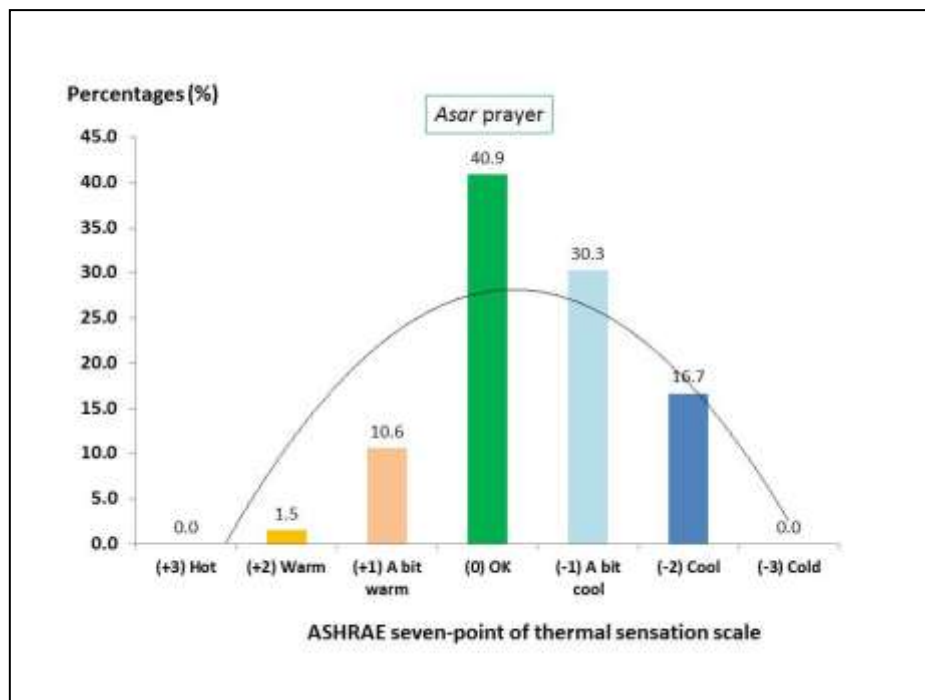

c) *Asar* prayer

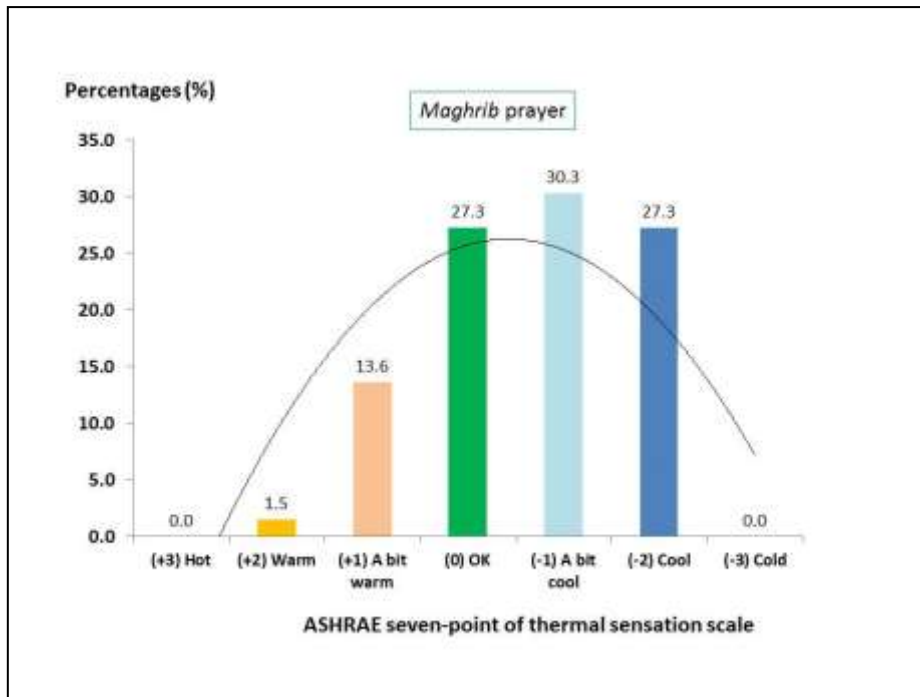

d) *Maghrib* prayer

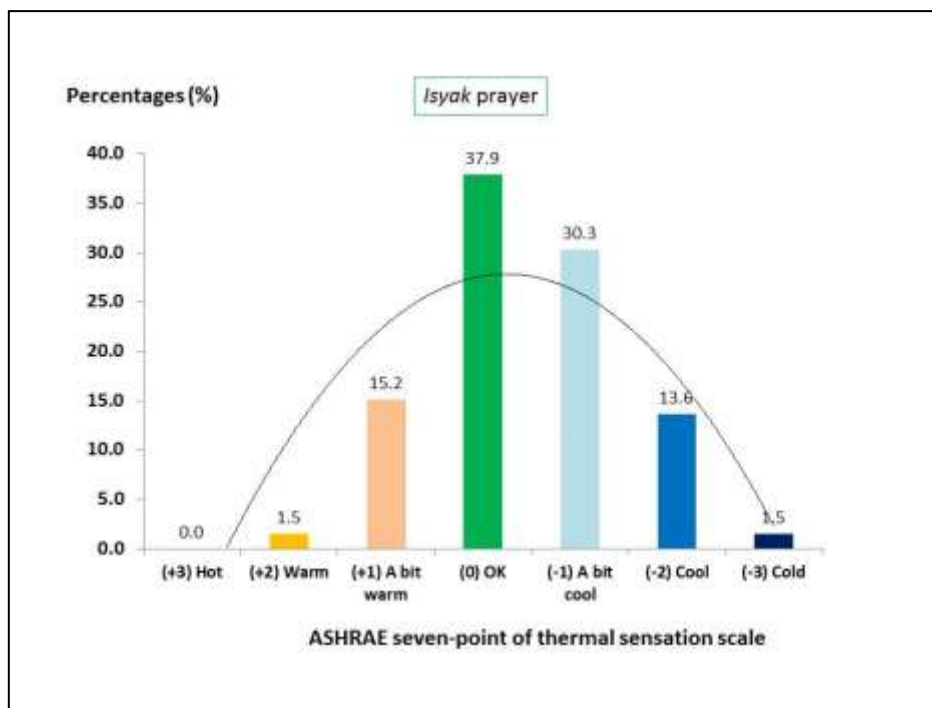

e) *Isyak* prayer

Figure 5: Thermal response based on ASHRAE seven-point thermal sensation scale
 Note: a) *Subuh* prayer, b) *Zohor* prayer, c) *Asar* prayer, d) *Maghrib* prayer, and e) *Isyak* prayer

Thermal preference of worshippers when exposed to the indoor thermal environment was evaluated. Worshippers were asked if they preferred to change the thermal environment they were experiencing (Table 5). The results show that more than half of worshippers preferred to change their thermal environment to cool during prayer times except for *Subuh* prayer which garnered only 48.5 %. Similar result was reported by Azizpour et al., (2013) in Malaysia case where most of the respondents preferred to change their thermal environment to cool. Observation of mean OPT temperatures show that worshippers were exposed to higher OPT temperatures during the prayer times. This differs from the finding by Azizpour et al., (2013) study where the mean OPT temperature was lower. One possible explanation might be that Mosque A/C operates the air condition on intermittent basis (i.e. only during prayer times), whereas in Azizpour's case the buildings which offer medical services were operating the air-conditioning system round-the-clock. Furthermore, Mosque A/C operates the air condition for a very large volume of air space in a very short period, and not in a fully-closed situation.

Table 5: Comparison of thermal preference votes

Researchers	% to be cool	% to be warm	OPT, °C
Kwok & Chun, (2003)	8.7	8.7	24.10
Al-ajmi & Loveday, (2010)	11	22	23.71
Al-ajmi, (2010)	19.5	11.6	23.98
Azizpour et al., (2013)	52.1	21.1	25.24
<u>This Study-Daily prayers</u>			
<i>Subuh</i>	48.5	1.5	27.46
<i>Zohor</i>	66.7	1.5	29.75
<i>Asar</i>	65.2	4.5	30.45
<i>Maghrib</i>	65.2	1.5	29.83
<i>Isyak</i>	56.7	4.5	27.93

3.5 PMV model predictions and actual mean vote (AMV)

In ideal case, the Actual Mean Vote (AMV) should relate equally to Predicted Mean Vote (PMV). AMV and PMV for all daily prayers have been investigated and plotted in linear regression graph as in Figure 6. The graphs represent the values of AMV and PMV as a function of Neutral Operative Temperature (Tn) for all prayer times. One dot represents the mean vote of 11 respondents in each daily prayer for duration of 6 days. Result shows that most of the dots are located below the zero line, thus the line slope of actual AMV and PMV is much lower than the theoretical. Moreover, to find out whether worshippers' who perform their daily prayer in Mosque A/C are satisfied with the level of indoor thermal conditions, the neutral operative temperature (Tn) is a key indicator. The linear regression analysis was then applied to determine the values of Tn Temperature for all prayer times. The outcome from the graph, the linear regression equations are listed below;

PMV = 0.1706Tn – 3.799;	AMV = 0.3531Tn – 10.533	- <i>Subuh</i> prayer
PMV = 0.3108Tn – 7.628;	AMV = 0.6453Tn – 19.807	- <i>Zohor</i> prayer
PMV = 0.2892Tn – 7.00;	AMV = 0.5179Tn – 16.271	- <i>Asar</i> prayer
PMV = 0.4046Tn – 10.494;	AMV = 0.6520Tn – 20.131	- <i>Maghrib</i> prayer
PMV = 0.2889Tn – 7.146;	AMV = 0.2975Tn – 8.689	- <i>Isyak</i> prayer

The gradient of the regression number indicates how sensitive the worshippers' were with their thermal environment for both predicted value and actual thermal response by subjective evaluation. The linear regression equation was then derived to zero for PMV and AMV in order to get the T_n temperature.

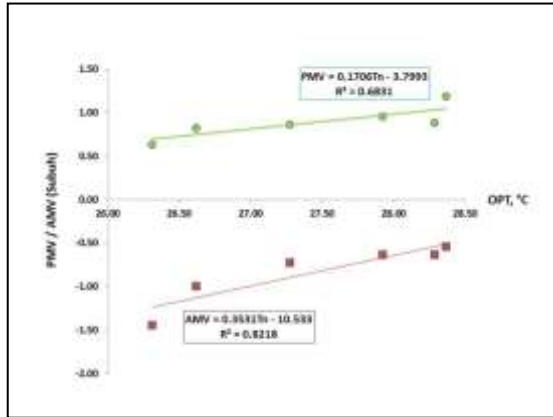

a) Subuh prayer

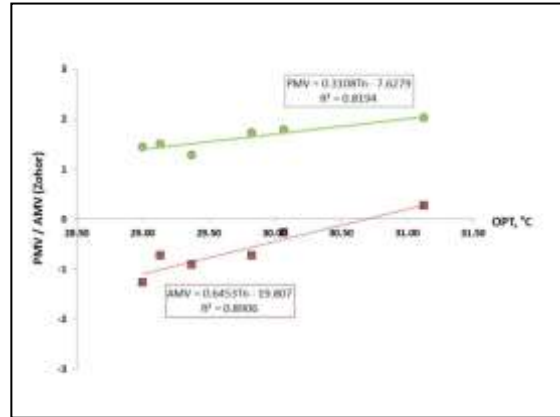

b) Zohor prayer

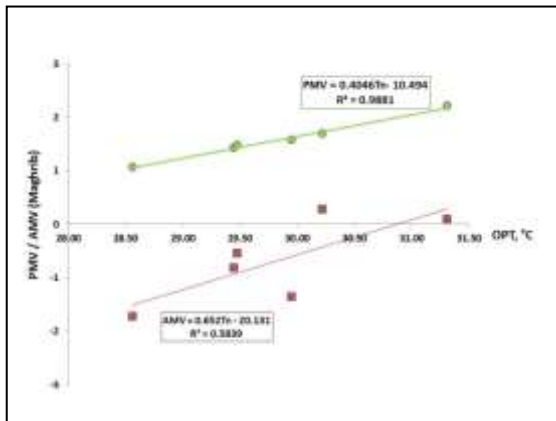

c) Asar prayer

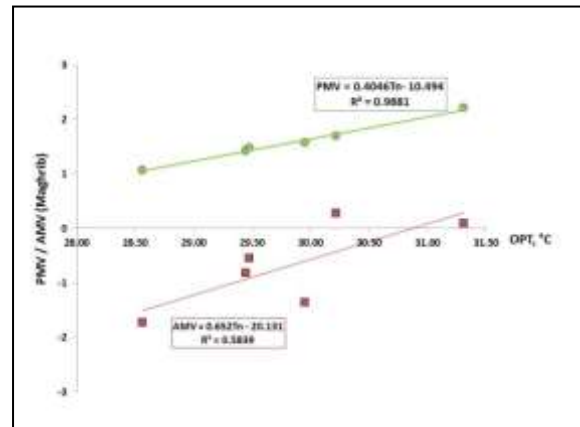

d) Maghrib prayer

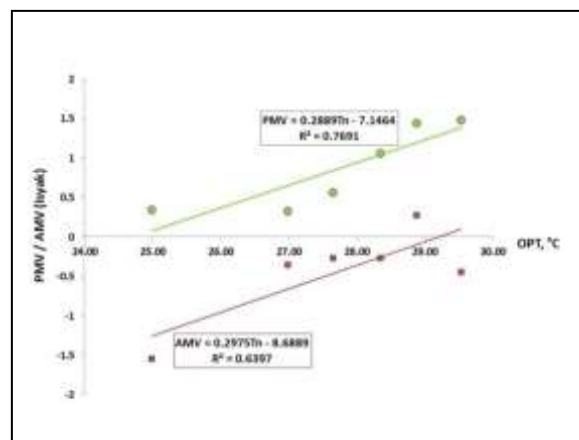

e) Isyak prayer

Figure 6: PMV, AMV and relation to Operative Temperature (OPT)

Table 6 shows the OT, OPT, PMV and AMV which were obtained from the regression equation methods. It clearly shows that PMV values underestimated the whole thermal conditions of the prayer times compared to AMV. The discrepancies range between the lowest of 4.47 °C (*Isyak* prayer) and the highest of 7.56 °C (*Subuh* prayer) where the variables factor such as clothes value, metabolism rate, air speed, relative humidity and mean radiant temperature (MRT) are involved in PMV prediction model. Meanwhile, observation of the relationship between OPT-AMV in daily prayer times shows there is a small amount of discrepancies. When the OPT was low (*Subuh* prayer: 27.46 °C), the AMV was slightly higher. Thus, the thermal sensation vote has discrepancy of 2.37 °C. In contrast, when the OPT was higher (*Zohor* and *Asar* prayer times), the discrepancy is only 0.94 °C and 0.97 °C, respectively. It is also noted that AMV values are also closer to OT values except for *Subuh* prayer time. This trend reflects a scenario akin to adaptive concept, but which needs further investigations.

Table 6: OT, OPT, PMV and AMV for daily prayer

Prayer time	OT (°C)	OPT (°C)	PMV (°C)	AMV (°C)	PMV-AMV diff (°C)	OPT-AMV diff (°C)
<i>Subuh</i>	26.61	27.46	22.27	29.83	-7.56	-2.37
<i>Zohor</i>	31.46	29.75	24.86	30.69	-5.83	-0.94
<i>Asar</i>	31.46	30.45	24.20	31.42	-7.21	-0.97
<i>Maghrib</i>	29.98	29.83	25.94	30.88	-4.94	-1.05
<i>Isyak</i>	29.50	27.93	24.74	29.21	-4.47	-1.28

3.6 Overall comfort temperature

The overall comfort temperature in Mosque A/C is determined based on the thermal acceptability of indoor environment as indicated in the ASHRAE Standard-55 (2013). This relates to the ASHRAE seven-point thermal sensation scale where the values must be within the limit of 80 % (± 1 of PMV) or 90 % (± 0.5 of PMV). Both limits are applicable due to personal behaviours, but the most widely accepted practice refer to respondents who vote inside the limit of (± 0.5) which represents the thermal comfort in the particular space. Thus, Figure 7 shows the deviation of PMV and AMV values at the limit of 90 % (± 0.5 of PMV) and the relationship to overall comfort temperature. The linear regression equation is then derived to zero (0) for PMV and AMV in order to get the overall Tn temperature. The overall Tn temperatures for PMV and AMV are thus determined to be 25.88 °C and 30.44 °C, respectively.

Table 7 shows the comparison of PMV and AMV values in several research works within hot climates. For Mosque A/C the difference is 4.56 °C. This significant difference may be due to the fact that the air-conditioning system used for such a large scale space is inappropriate and ineffective due to the short period of operation.

Ultimately, the comfort temperature was determined by applying deviation of PMV and AMV at the limit (± 0.5) of thermal sensation response: Thus, an operative temperature was found to be in the range of 26.99 °C to 31.41 °C, respectively which represent the overall comfort temperature in Mosque A/C during the daily prayer modes (Figure 8).

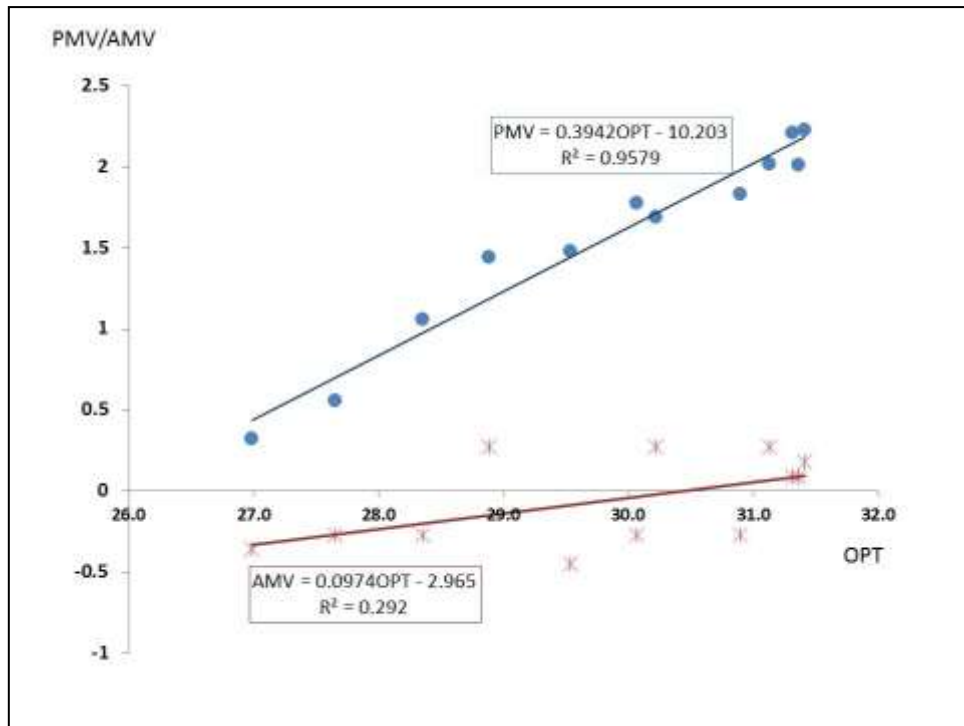

Figure 7: Deviation of PMV and AMV at the limit of (± 0.5) and relationship to overall comfort temperature

Table 7: Comparison PMV model predictions and AMV in this case study and other studies

Buildings, countries	PMV (°C)	AMV (°C)	Diff. (°C)	Researchers
Housing, Kuwait	23.3	25.2	-1.90	Al-ajmi & Loveday, 2010
Hospital, Malaysia	24.49	26.46	-1.97	Azizpour et al., 2013
A/C Mosque, Kuwait	23.3	26.1	-2.80	Al-ajmi, 2010
Mosque A/C, daily prayer	25.88	30.44	-4.56	This study

Indoor climate of Mosque A/C was compared to the ASHRAE Standard-55, (2013) comfort zone. Observation of the daily pattern of OPT temperature shows that thermal comfort specified by ASHRAE Standard-55 was hardly achieved in Mosque A/C building during the daily prayer times (Figure 9). Only during *Subuh* prayer it almost reached to the upper limit of the ASHRAE comfort zone. Based on the findings and nature of current building operation, new comfort temperature for worshippers' in Mosque A/C building is recommended by shifting about 3.99 °C to 4.91 °C from the lower and upper limits of the thermal comfort boundary in the Standard.

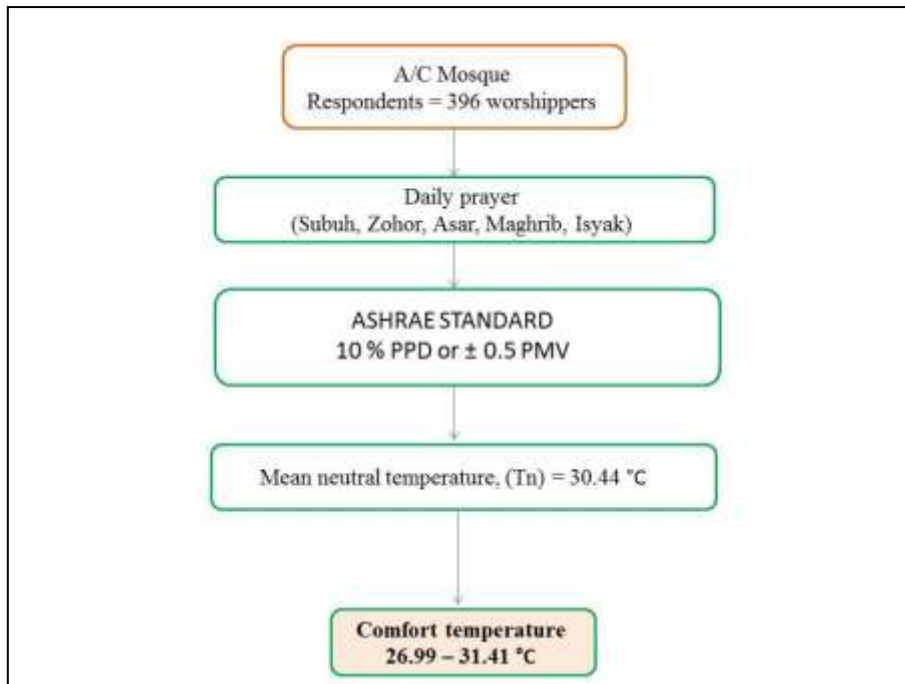

Figure 8: Overall comfort temperature

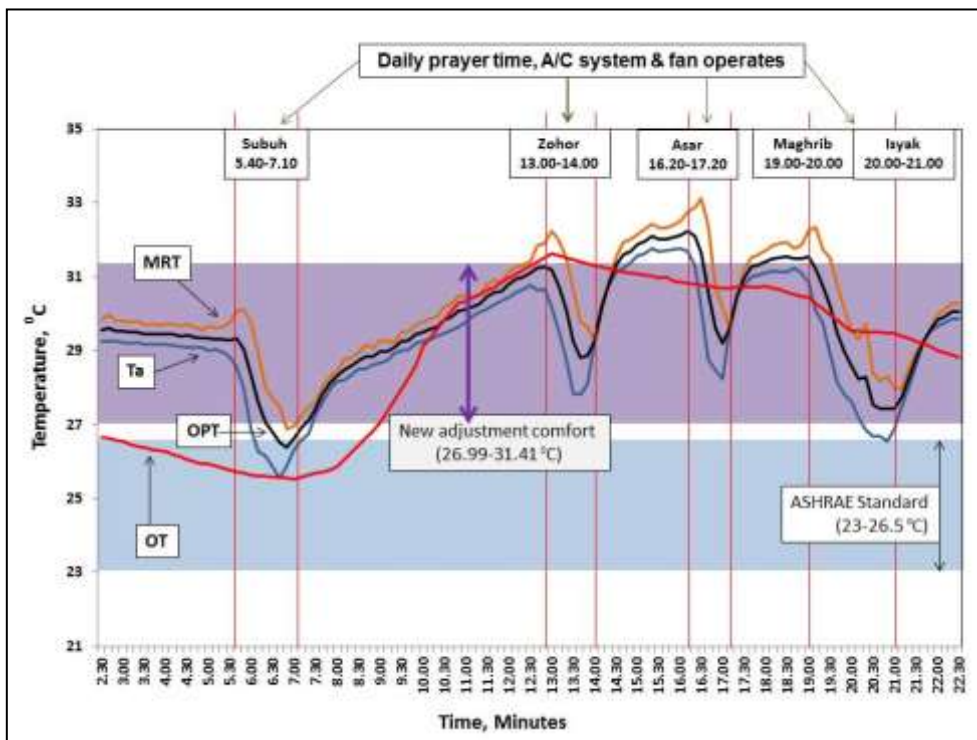

Figure 9: Indoor climates compared to comfort zone from ASHRAE Standard
 Note: Ta =Indoor Temperature; MRT =Mean Radiant Temperature; OPT= Operative Temperature;
 OT = Outdoor Temperature

4. Energy Cost for Mosque A/C

The function of the air-conditioning system is to address the heat load of buildings with cooling and to produce comfort to occupants. Saidur, (2009) in his report mentioned that Malaysian buildings consumed 57 % of the energy in operating the air conditioning system, which is higher than Indonesia (51 %), Saudi Arabia (50 %), Spain (52 %) and USA (48 %). This is a big percentage of expenditure to be allocated for operation of air conditioning system and to meet the comfort demand. However, the nature of activities in a mosque building differs from that of an office building.

Figure 10 shows the electricity cost for Mosque A/C for the year 2012. The average cost per month of electricity consumption is RM 2,983.00. Without delving into fine details, it can be seen that the cost for November is marginally less than that for April, reflecting the seasonal climatic variation. The highest usage in September coincides with the *Ramadhan* fasting month, during which intensive activities take place in a mosque such as breaking the fast, the special night prayers of *terawikh* (pre-midnight) and *qiamullail* (after midnight) as well as *ikhtiqaf* (contemplation in MPH) besides the five daily prayers. The month preceding *Ramadhan*, known as *Syaaban*, coincides with August. This is the time when activities in the mosque start to pick up pace in anticipation of *Ramadhan* with more worshippers' attending the daily prayers and other religious gatherings. October coincides with *Syawal* during which the *Eidil Fitr* is celebrated (locally known as *Hari Raya Puasa*) whereby families will spend more time visiting each other. During this time the activities in mosques normally subside before picking up again.

Figure 11 shows the annually monthly mean OT thermal environmental data from nearby Butterworth weather station of the Meteorological Department of Malaysia for the past ten years (2003-2012). It clearly shows the month of April and May have highest OT, whilst October and November have the lowest monthly OT. It is to be noted that almost all operational costs of a *qariah* mosque is born by the local community through contributions and occasional fund-raising activities. The community elects a mosque committee to manage its affairs.

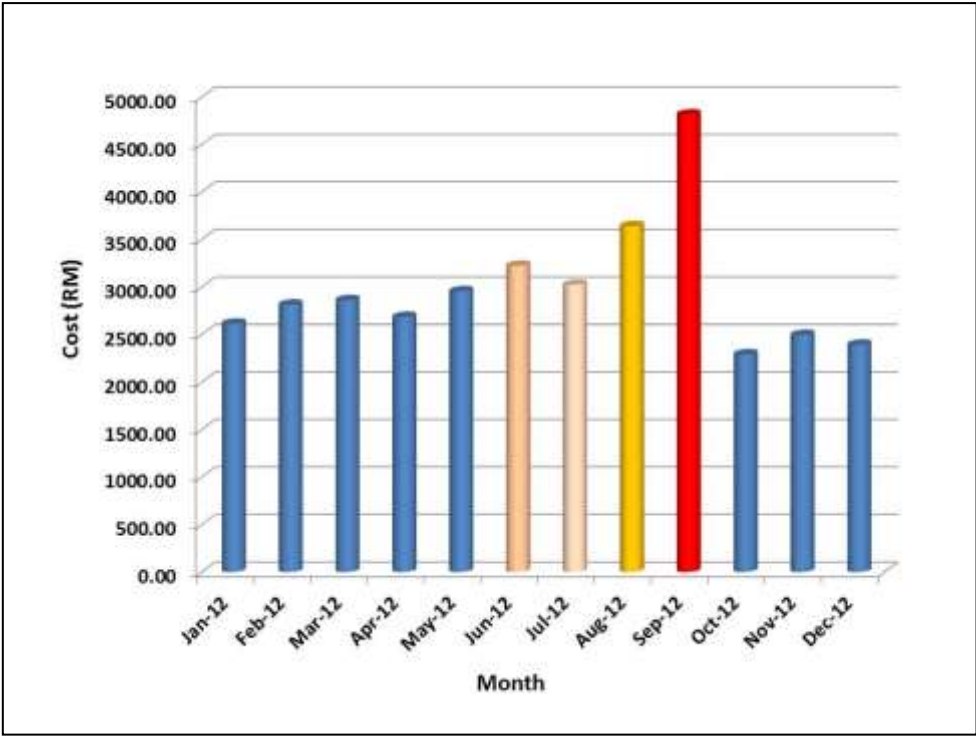

Figure 10: Electricity cost of Mosque A/C for January-December 2012

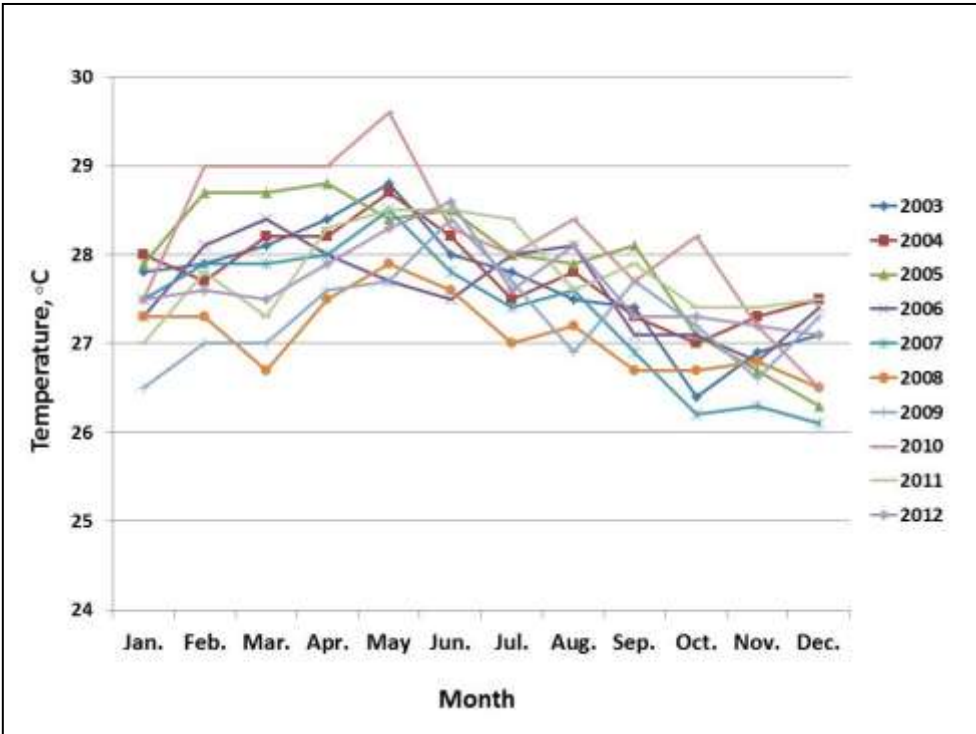

Figure 11: Annual monthly mean Outdoor Temperature (OT) for duration 2003-2012

5. Conclusions and recommendations

The findings can be summarized as follows:

- The most common clothes worn by the worshippers' during daily prayer times in Mosque A/C are traditional Malay long sleeve shirt paired with *kain sarung*. In addition, worshippers from nearby offices wear their normal working attire of long sleeve shirt paired with normal trousers.
- Based on the ASHRAE seven-point thermal sensation scale, it is indicated that the distribution of votes for *Subuh*, *Zohor* and *Maghrib* prayers tends toward cool condition but *Asar* and *Isyak* prayers have a normal distribution of votes.
- Worshippers' preference for cooler conditions in most of the prayers times.
- The underestimation of thermal conditions using the PMV model compared to the actual thermal sensation (AMV) shows that worshippers' behaviour with past experience of higher climatic conditions has a preference to adapt with the internal thermal environment that they are exposed to either lower or equal to the outdoor temperature.
- The results indicate that thermal environment in Mosque A/C could hardly achieve the comfort zone as proposed in ASHRAE Standard-55, (2013). This implies that thermal comfort conditions in Malaysian mosques of similar design and operation to Mosque A/C cannot co-relate well with the ASHRAE- standard.
- The recommended new comfort temperature for Mosque A/C is 3.99 °C to 4.91 °C from lower and upper limits of the ASHRAE thermal comfort boundaries.
- The outdoor thermal environment is reflected in the use pattern of electricity in Mosque A/C, with drastic increases due to seasonal religious activities related to the fasting month of *Ramadhan*.

It is recommended that further studies be done to investigate the most appropriate and economical method to provided thermal comfort conditions in Malaysian mosque buildings, given the nature and frequency of religious activities involved as well as the design of the indoor spaces.

6. Acknowledgements

We gratefully acknowledge the cooperation of officers of Masjid At-Taqwa, Kepala Batas Penang Malaysia, with special mention to mosque Committee Members, Tuan Haji Ir. Ahmad Zakiyuddin (The Chairman), Tuan Haji Abdul Rahman (The Honorary Secretary) and worshippers for their continuous support and participation during the field study.

References

- Al-Ajmi, F.F., 2010. Thermal comfort in air-conditioned mosques in the dry desert climate. *Building and Environment*, 45, pp 2407-241.
- Al-Ajmi F.F., Loveday D.L. & Havenith, G., 2006. Thermal insulation of Arabian Gulf male clothing: measurements using a thermal manikin. *ASHRAE Transactions*, 112(2).

- Al-ajmi, F.F. and Loveday, D.L., 2010. Indoor thermal conditions and thermal comfort in air-conditioned domestic buildings in the dry-desert climate of Kuwait. *Building and Environment*, 45, pp 704-710.
- Al-Homoud, M.S., Abdou, A.A. and Budaiwi, I.M., 2009. Assessment of monitored energy use and thermal comfort conditions in mosques in hot-humid climates. *Energy and Buildings*, 41, pp 607–614.
- ASHRAE Standard-55., 2013. Thermal environmental conditions for human occupancy. Atlanta, Georgia: *American Society of Heating, Refrigerating and Air-conditioning Engineers*, Inc.
- Azizpour, F., Moghimi, S., Salleh, E., Mat, S., Lim, C.H. & Sopian, K., 2013. Thermal comfort assessment of large-scale hospitals in tropical climates: A case study of University Kebangsaan Malaysia Medical Centre (UKMMC). *Energy and Buildings*, 64, pp 317-322.
- Hoyt, T., Schiavon, S., Moon, D. & Steinfeld, K., 2012. CBE Thermal Comfort Tool for ASHRAE-55. Center for the Built Environment, University Of California Berkeley. <http://cbe.berkeley.edu/comforttool/>
- ISO 7730., 2005. Ergonomics of the thermal environment-Analytical determination and interpretation of thermal comfort using calculation of the PMV and PPD indices and local thermal comfort criteria.
- Kwok, A.G. & Chun, C., 2003. Thermal comfort in Japanese schools. *Solar Energy*, 74, pp 245-252.
- Nicol, J.F., 2004. Adaptive thermal comfort standards in the hot–humid tropics. *Energy and Buildings*, 36 (7), pp 628–637.
- Nicol, J.F. & Humphreys, M.A., 2002. Adaptive thermal comfort and sustainable thermal standards for buildings, *Energy and Buildings*, 34 (6), pp 563-572.
- Orasa, J.A. & Oliveira, A.C., 2011. A new thermal comfort approach comparing adaptive and PMV models. *Renewable Energy*, 36, pp 951-956.
- Saidur, R., 2009. Energy consumption, energy savings and emission analysis in Malaysian office buildings. *Energy Policy*, 37, pp 4104-413.
- SPSS, 2012. IBM Statistical Product and Service Solutions, Version 20.0.

A holistic approach to comfort in offices

Eefke van den Ouweland¹, Wim Zeiler¹, Yvonne de Kort¹, Gerarda Nierman², Gert Boxem¹ and Wim Maassen²

¹ University of Technology Eindhoven, Netherlands, w.zeiler@bwk.tue.nl

² Royal HaskoningDHV, Rotterdam, Netherlands

Abstract

In the field of building design a rather conservative culture dominates: during the design process, standards are used to achieve physiological comfort. Physiological comfort is a necessity in order to achieve psychological comfort and eventually occupant satisfaction and overall wellbeing. To achieve occupant satisfaction and wellbeing, physiological comfort as well as psychological comfort have to be met. Psychological comfort can be defined as a sum of six distinct components: self acceptance, personal growth, purpose in life, positive relations with others, environmental mastery and autonomy. Salutogenesis provides a theory which describes a positive approach in psychological wellbeing. In this research, the knowledge from psychology is combined with knowledge on the traditional design approach to develop a holistic solution to create overall comfort. The current design approach provides a threshold level for physiological comfort, while manageability, comprehensibility and meaningfulness provide psychological comfort.

Keywords: Holistic approach, comfort, psychological wellbeing, salutogenesis

1 Introduction

The indoor environment in office buildings which have been designed according to the latest standards still result too often in dissatisfaction and discomfort among building occupants. One of the causes of this problem is the current design practice which commonly focuses on physiological comfort and energy reduction. Research has shown that more (psychological) aspects are important for the health, overall wellbeing and satisfaction of building occupants [Huisman et al, 2012]. However, findings from psychology remain scattered and poorly linked to the engineering and design disciplines that might make use of it [Veitch et al, 2007]. This indicates that the required knowledge and theories to increase the productivity and satisfaction in offices is possibly available already among psychologists. This research responds to this existing gap, by investigating and identifying the (psychological) aspects which remain underexposed or even neglected during the current design practice. Secondly, designers and facility managers continue to ask for demonstrable proof on how the indoor environment influences organizational outcomes [Veitch et al, 2007]. Lots of studies suggest that the productivity is increased by a positive indoor environment, although there is a lack of information on how this positive indoor environment can be designed or what the actual effect on the organizational outcome will be.

2 Methodology

2.1 Theoretical framework

In this research, the knowledge from psychology is combined with knowledge on the current design practice to develop a holistic solution to the aforementioned problem. The current

design practice provides a threshold level for physiological comfort, while the salutogenesis theory provides psychological comfort. A holistic approach is here defined as a design approach for the indoor environment which aims at promoting the health of building occupants. It is important to realize that health in this context considers the state of complete *physical, mental* and *social* wellbeing of building occupants [World Health Organization, 1948].

The thermal comfort standards describe values for indoor environmental parameters, like temperature and ventilation rate, to accomplish less than the maximum allowed percentage of dissatisfied people. The environmental comfort model of Vischer, see Fig. 1, states that a workspace either supports the tasks and activities that are being performed there (comfort condition), or it fails to support them and in fact slows them down (uncomfortable condition and cause of stress) [Vischer, 2005, cited by Vischer, 2007]. Depending on the tasks they are performing, employees are more or less affected by environmental factors such as lighting, furniture layout and ergonomics, noise level and temperature.

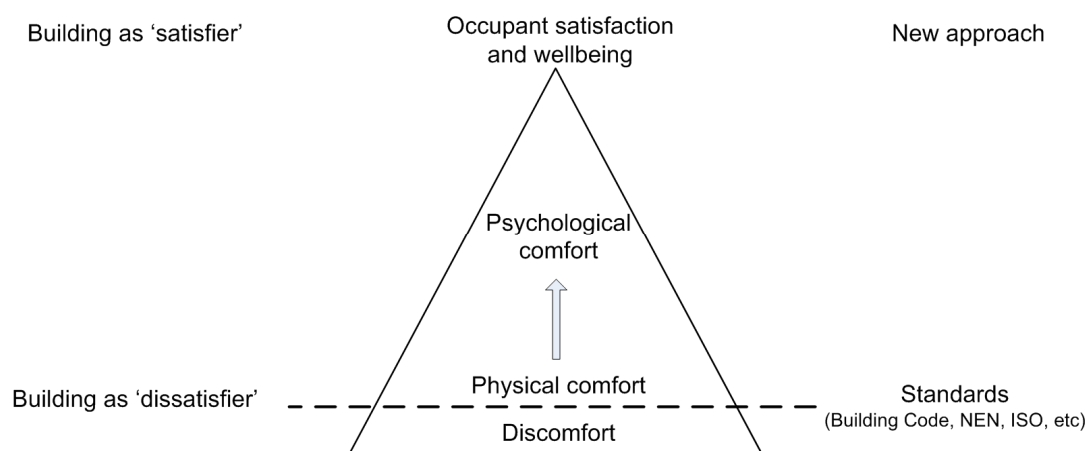

Figure 1. The adapted 'Habitability' pyramid of Vischer [Vischer, 2005, cited by Vischer 2007]

2.2 Salutogenesis: Health promotion

From a research perspective, health can be divided into a pathogenic and salutogenic starting point according to Dilani [Dilani, 2008]. Pathogenic research focuses on disease prevention, while salutogenic research is based on identifying wellness factors that maintain and promote health, rather than investigating factors that cause disease [Dilani, 2008]. Therefore, this research will aim to develop a salutogenic design approach for the indoor environment in offices. Aaron Antonovsky was the founding father of salutogenesis [Antonovsky, 1979]. He developed a salutogenic model which focuses on factors that support human health and well-being, rather than on factors that cause disease. The evidence proves Antonovsky's salutogenic model as a health promoting resource that improves resilience and develops a positive subjective state of both physical and mental health, quality of life and wellbeing. The model can be explained in terms of "sense of coherence" (SOC) and "generalized resistance resources" (GRR's). In Antonovsky's [Antonovsky, 1979] formulation, the sense of coherence has three components:

1. Comprehensibility: A belief that things happen in an orderly and predictable fashion and a sense that you can understand events in your life and reasonably predict what will happen in the future;
2. Manageability: A belief that you have the skills or ability, the support, the help, or the resources necessary to take care of things, and that things are manageable and within your control;

3. **Meaningfulness:** A belief that things in life are interesting and a source of satisfaction, that things are really worth it and that there is good reason or purpose to care about what happens.

Antonovsky [Antonovsky, 1979] defines generalized resistance resources as “any characteristic of the person, the group, or the environment that can facilitate effective tension management”. GRR’s determine which specific resistance resources are available to a person [Antonovsky, 1979]. It is believed that enrichment of GRR’s enhances workers’ comprehensibility, manageability and meaningfulness. In other words, it leads to the enhancement of the sense of coherence [Yamazaki et al, 2011]. Research done by Yamazaki et al, states that studies on workplace conditions that can enhance workers’ SOC are extremely important, as they suggest the possibility of changing the work environment, in addition to the attempt to directly change workers [Yamazaki et al, 2011]. These studies have suggested that the workplace with greater job discretion, good communication, a supportive atmosphere, and respect shown to workers is likely to enhance workers’ sense of coherence [Yamazaki et al, 2011]. Given that the workplace is where most people spend a large percentage of their waking hours, the relationship between SOC and work is an area of interest. Strümpfer and Cederblad et al. have studied this area extensively and say that having high SOC will result in the person [Strümpfer, 1990, cited by Breda, 2001] [Cederblad et al, 1994, cited by Breda, 2001]:

- Making cognitive sense of the workplace, perceiving its stimulation as clear, ordered, structured, consistent and predictable information;
- Perceiving his/her work as consisting of experiences that are bearable, with which (s)he can cope, and as challenges that (s)he can meet by availing him-/herself of personal resources or resources under the control of legitimate others;
- And making emotional and motivational sense of work demands, as welcome challenges, worthy of engaging in and investing his/her energies in;
- Confronts stressors, is capable of clarifying and structuring the nature of the stressor;
- Believes that the appropriate resources are available and can be mobilized to deal successfully with the challenge and is motivated to deal with it.

According to research done by Bond and Galinsky the effectiveness of the work environment strongly correlates with job satisfaction and job retention when considering value drivers that focus on the ‘whole person’ [Bond and Galinsky, 2006]. Furthermore, research done by Strümpfer and De Bruin and Rothmann and Venter provides evidence of a strong relationship between sense of coherence and job satisfaction [Strümpfer and de Bruin, 2009] [Rothmann and Venter, 2010]. Another research, performed by Strümpfer and Bruin, collected data on the relationship between sense of coherence (SOC) and job satisfaction (JS) from published sources, unpublished theses and unpublished reports [Strümpfer and de Bruin, 2009]. The results show that SOC accounted for approximately 25% of the variance in job satisfaction. These findings support the hypothesis that a manageable, meaningful and comprehensible indoor environment results in enhanced satisfaction.

2.3 Means-end chain theory

The first step in the development of a holistic design approach considers the determination of the needs of building occupants in regard to the indoor environment in offices. This was done with the use of the means-end chain theory which originates from consumer psychology [Gutman, 1982]. The indoor environmental components are considered as products which can be used by building users to achieve their values. The means-end chain theory is a theory

which is commonly used in consumer psychology to determine the needs of individual humans in regard to a certain product [Reynolds and Olson, 2001]. This theory presents the relation between an individual person and a product as a means-end chain. The means-end chain involves three elements: attributes (A), consequences (C) and values (V). Attributes are external properties or aspects of products. Consequences are defined as the results which are experienced by an individual person while using the product and the values refer to the fundamental needs of humans. According to the means-end chain theory, people continuously use their values to make decisions between possibilities. During a ladder interview, which is performed in a one-on-one setting, the ‘why-question’ can be considered as basis [Reynolds and Olson, 2001]. The respondent is repeatedly confronted with the question: “Why is that important to you?”, which eventually leads the respondent towards a high level of abstraction. The result of a ladder interview is an overview of the relations between attributes (A), consequences (C) and values (V).

Starting with the meaning structure analysis is the same as the content analysis for the correspondence analysis. The numbered categories are used to score each element in each ladder producing a matrix with rows representing an individual respondent’s ladder. From this matrix can be derived how often one element results in a subsequent element. The relations between attributes, consequences and values can be either indirect or direct. The final result is known as a Summary Implication Matrix (SIM), in which each cell indicates the number of times directly and indirectly all row elements lead to all column elements [Reynolds and Olson, 2001]. The SIM is used to develop an Hierarchical Value Map (HVM), this is a map which represents the chains between the aggregated ladders. To avoid confusion, the term “ladder” will refer to the results from individual respondents while the term “chains” will be used in reference to sequences of elements which are derived from the SIM [Reynolds and Olson, 2001]. Fig. 2 illustrates this relation between ladders and chains.

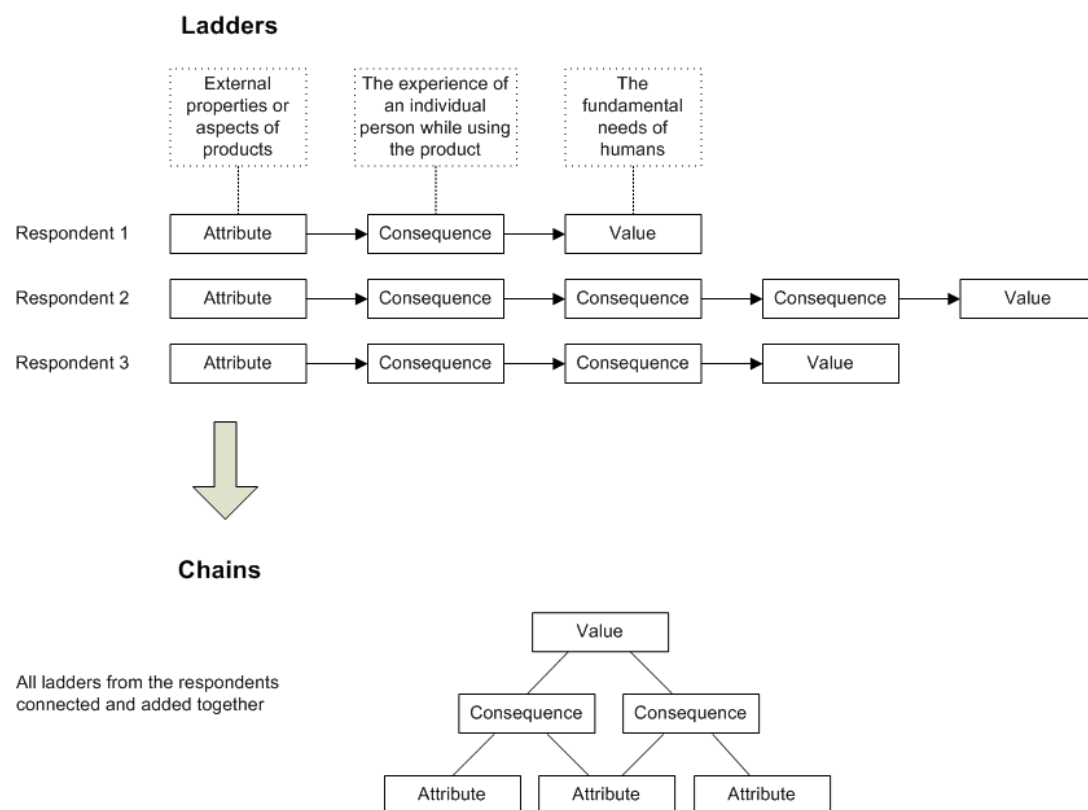

Figure 2. Schematic representation of the relation between ladders and chains in a HVM

Means-end chains of individual persons can be derived with the use of the ladder interview technique. This technique considers an in-depth interview in a one-on-one setting. During a ladder interview, the question ‘Why is that important to you?’ plays a central role. By asking why a certain property of the indoor environment is considered as important by an individual human, the means-end chains of an attribute develops. Eventually this process results in a value which is accomplished with the use of the attribute. Two types of analysis are applied to the results from the ladder interviews. The first one is the correspondence analysis, this statistical analysis is used to determine associations between variables. Correspondence analysis is a method for exploring associations between sets of categorical variables. The analysis of the results of multiple ladder interviews consists of three phases. During the first phase, an content analysis of all the elements from the ladders is applied [Reynolds and Olson, 2001]. The first step of the content analysis is to record the entire set of ladders across respondents on a separate coding form. The next step is to develop a set of categories that reflect everything that was mentioned in the interviews. The results from this analysis are used as input for the subsequent questionnaire. The second analysis is the meaning structure analysis. The results from the ladder interviews are represented in a hierarchical value map which shows both qualitative and quantitative information. From this map was derived how specific properties of the indoor environment are used by humans to achieve certain values. These values correspond with the physical or mental condition which is desirable for the building occupants at the office. Additionally, the hierarchical structure of the map provides information on the relative importance of properties of the indoor environment. These results are useful in the design process when different design variants are analyzed. In summary, the results from the ladder interviews explain how to design an indoor environment which satisfies building users. The results can be further analyzed by a regression analysis.

A regression analysis is a method which is used to estimate the relationships among variables. The aim of the analysis is to define the relationship between dependent and multiple independent variables. The result from the regression analysis provides understanding on how the dependent variable changes when the independent variables are varied. The variation is in this research a result of the different case buildings which have been used to select the respondents. The regression analysis is performed in SPSS and the procedure consists of several steps.

3 Experiments

During the ladder interviews, respondents in multiple office buildings were asked which properties they considered as important in the indoor environment of the office and why. During the research, seven office buildings are used as case studies to perform interviews and questionnaires. Additionally, the building services of the office buildings are analyzed to determine the quality of the indoor climate. The building occupants of the case buildings are used as respondents for the interviews and questionnaires. The ladder interview technique is used to reveal means-end chains between physical characteristics of the indoor environment and values which are important to humans in regard to the indoor climate. The respondents in the first step of this research were building users of three out of the seven selected office buildings in the Netherlands. In order to get representative results, the respondents are chosen as diverse as possible within one office building. Selection criteria include age, gender, job description and location within the building.

The interview can start either by ordering the characteristics of a product or by preference between multiple products [Reynolds and Olson, 2001]. If preference is used, the interview continues by asking why this product has the preference of the respondent. When ordering of characteristics is used, the characteristics which are derived from the interview

will be used for laddering. The ladder interview technique has been developed specifically to create means-end chains. Laddering is an interview technique which can be used to determine the purposes of product consumers. In this research is chosen to select a product based on preference since it is desirable to ladder multiple product aspects and more in-depth answers are derived. The products are the indoor climate and its systems. Based on evidence from literature, ten photo collages of three to six products have been created for the interviews (see Figure 3). These photo collages are used as stimulus material to guide the respondents in a certain direction. Each collage represents one important component of the indoor environment. These are the components which are used: Heating; Cooling; Ventilation; Solar shading; Windows; Electrical lighting; Interior; Location of control systems; Design of control systems and Workplace concept.

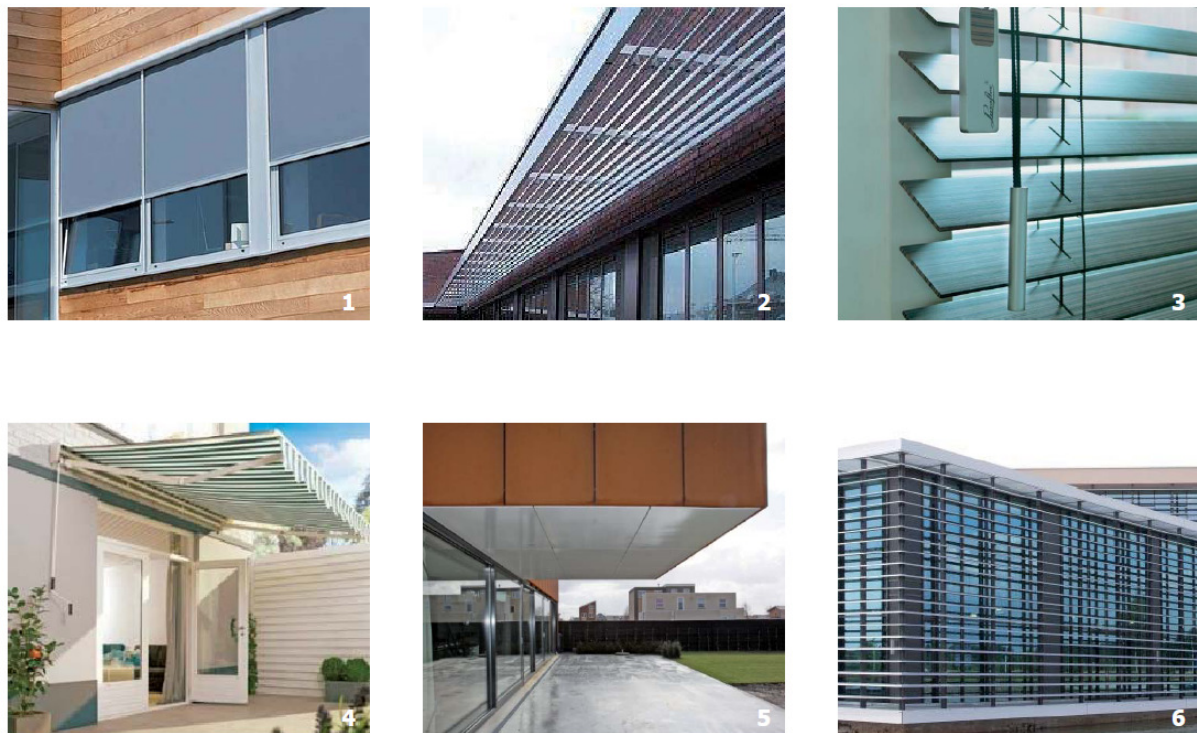

Figure 3. Photo collage of solar shading systems which is used during ladder interviews

The next step in the research focused on investigating whether a holistic indoor environment has a (positive) effect on the building occupant. A questionnaire was distributed among multiple office buildings with different indoor environments. The questionnaire was distributed by mail among 250 respondents. With a response rate of 64,4%, the questionnaire was completed by 161 respondents. The questionnaire included six predictive variables. In order to get reliable results it is necessary to have at least 20 to 30 respondents per predictive variable. When dividing all 161 respondents among the six variables, each variable has almost 27 respondents, which is sufficient. The items in this questionnaire measure the effect of the indoor environment on humans by means of satisfaction, health, productivity and burnout.

4 Results

4.1 Ladder interviews

A total of 21 respondents in 3 case buildings participated in the interviews. The ladder interviews are first analyzed with the use of a correspondence analysis to define clusters. Secondly, the meaning structure analysis is applied. This analysis provides an hierarchical

overview of the environmental aspects and corresponding purposes which are considered as most important by building users. The last step in the analysis of the data from the interviews is to develop a morphological model with the use of a methodological design approach. This model aims at translating the theoretical results from the research into applicable solutions which are useful during the design process of an office building.

4.2 Correspondence analysis

Within his analysis method the figures which are derived from the correspondence analysis represent the relations between the different attributes, consequences and values. The smaller the distance between two points, the stronger the relation between the elements. The value of the inertia per dimension is comparable with the percentage of explained variance. In this Summary Implication Matrix, the inertia of the dimensions is considered as acceptable when the value is 30% or higher. Furthermore, each figure from the correspondence analysis represents two elements: either attributes and consequences, consequences and values or attributes and values. With the use of Fig. 4, clusters are composed. The Score in Dimension displays each row's score on dimension 1 and dimension 2. The scores are derived based on the proportions (mass) for each cell, column, and row when compared to total sample; the scores are representative of dimensional distance and are used in the graphs. In each cluster, the attributes, consequences and values which have a strong relation are joined together. These clusters are used in this research to formulate the items for the questionnaire. In the attributes-consequences analysis, the inertia of dimension one is 19% and the inertia of dimension two is 15%, which results in a total inertia of 34%. Fig. 4 illustrates the relations between attributes and consequences.

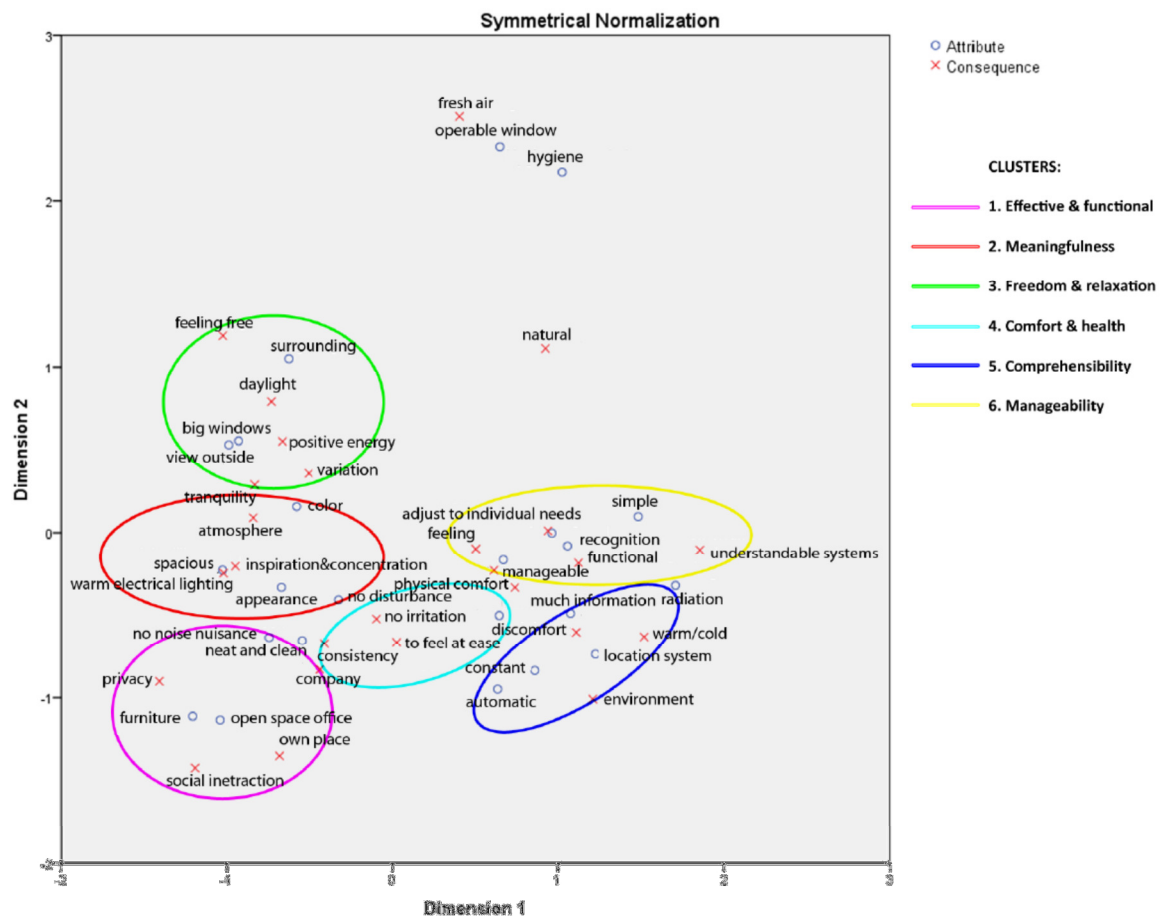

Figure 4. Correspondence analysis: Attributes and consequences – General analysis

With the knowledge and theories from literature in mind, five main clusters are extracted from this figure. These are the clusters from Fig. 4:

1. Furniture [A], Open/combi office [A], Noise nuisance [A], Neat and clean [A], Privacy [C], Social interaction/communication [C], Personal place [C], Beneficial for company [C]
2. Color [A], Appearance [A], Warm and clear electrical lighting [A], Inspiration and concentration [C], Atmosphere [C], Clear and spatial [C], Tranquility [C]
3. Surrounding environment [A], Big windows [A], View outside [A], Much daylight [C], Not feeling trapped [C], Positive energy [C], Variation [C]
4. Suffer from air related problems [A], No distraction [C], Enjoying yourself [C], Physical condition [C]
5. Location of the system [A], Radiation [A], Centralized and automatic [A], Constant [A], Information and settings [A], Saving time [C], Environment [C], Heat and cold sensation [C]
6. Manageable [A], Easy [A], Uniformity [A], Recognition and experience [A], Know how something works [C], Feeling [C], Adjust to individual needs [C], Functional [C], (Un)pleasant [C]

4.3 Meaning structure analysis

The information from the Summary Implication Matrix is used to develop a Hierarchical Value Map (HVM). The HVM provides a clear overview of the existing relations between attributes, consequences and values. This paragraph presents the HVM's of the general analysis and the four sub-analysis. The lines which represent the relations between elements are labeled with numbers. The number before the dot indicates the direct relations between elements and the number after the dot indicates the indirect relations. A relation is called an indirect relation when it exists via another element, which is not represented in the model. If a relation exists only indirectly, the line is dotted. When the relation exists either directly or both directly and indirectly it is indicated with a solid line. The hierarchical value map is constructed in correspondence with the structure of Fig. 5. To emphasize this structure, the map is divided into three horizontal panes. The lower part of the hierarchical value map represents the attributes, the middle part the consequences and the upper part the values. When this information is translated for the indoor environment, can be concluded that the lower part of the figure consists of specific characteristics of the indoor environment while the higher part consists of goals with a high level of abstraction. From the hierarchical value map can be determined how people aim to achieve goals with the use of the indoor environment. From Fig. 5 can be derived which specific aspects are experienced as important for building users in achieving health, comfort, performance at work, relaxation and feeling at ease. For example, inspiration and concentration are considered as very influential for performing well at work. At the same time, can be derived from the figure which factors people mention that contribute to the experienced level of inspiration and concentration. According to the results from the interviews are noise nuisance (6.5), the view outside (7.5) and the degree of personal control (7.4) key elements in the perceived level of concentration and inspiration. This way, these results help designers to understand and anticipate on the needs and expectations of building users. Furthermore, an hierarchical structure is developed which can be helpful in decision making during the design process.

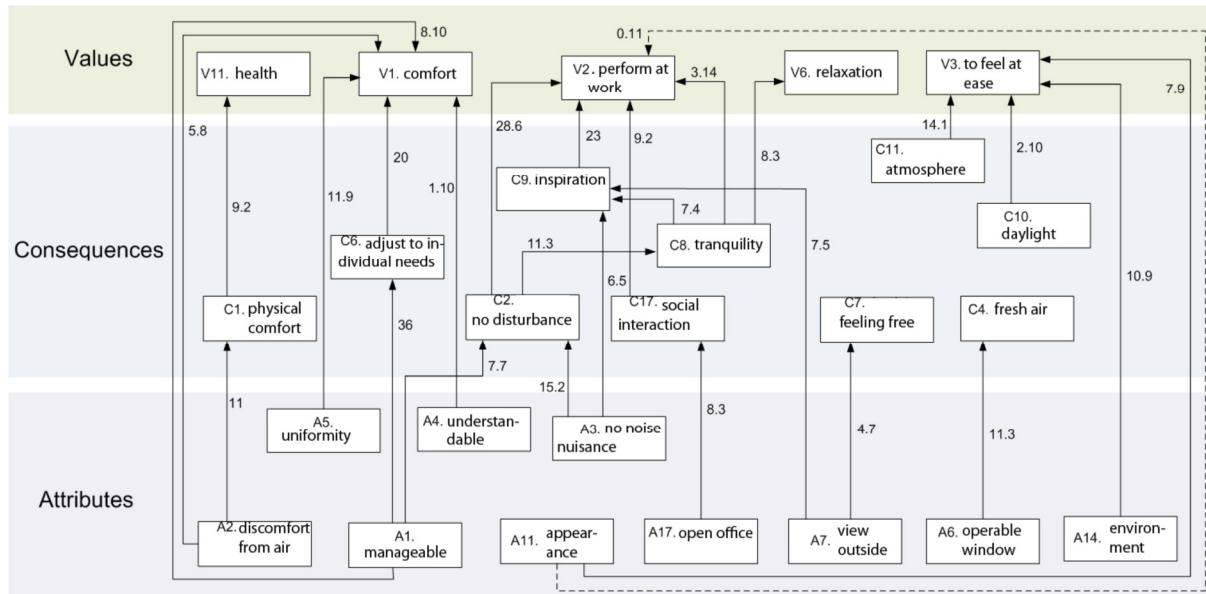

Figure 5. Hierarchical Value Map – General analysis

4.4 Multiple linear regression analysis

In this analysis, the relationship between the dependent variables and the independent variables is estimated, see Table 1.

Table 1 Results of regression analysis

Dependent variables	Beta values of the significant predictors (P < .05)							Total explained variance (R ² adjusted)
	Meaningful indoor environment	Effective & functional indoor environment	Comprehensible indoor environment	Manageable & natural indoor environment	Annoying stimuli at the workplace	Relaxation at the workplace	Physical discomfort at the workplace	
Subjective health	.297					.214	.157	.267
Subjective productivity		.340	-.146		.258			.247
Satisfaction with building	.285			.562				.581
Burnout	.400							.352

Subsequently, the internal consistency of the items which measure the same variable is verified and the actual variables are computed. Eventually a correlation analysis was performed, see table 1 to check whether any independent variables correlate strongly. If this was the case these variables were merged into one variable. Once all these steps were completed, the regression analysis was performed for each dependent variable.

5 Discussion and conclusions

This study, as described in this report, deals with the effect of the indoor environment on wellbeing and performance of building occupants in offices. Both the indoor environment and the human wellbeing and performance are very complex concepts. The salutogenesis theory is considered as main concept because findings from multiple researches provided evidence on the importance of manageability, comprehensibility and meaningfulness in the work environment. Since these are the building blocks of salutogenesis, these researches support the applicability of this theory in the indoor environment. Furthermore, Anthovsky's theory focuses on promoting human wellbeing according to the bottom-up approach in which the human being is the central point of interest.

The laddering technique is in this research applied in a new context. To make the method applicable for the indoor environment it was necessary to change the procedure. Given the complexity of the laddering technique and the diversity of the indoor environment, the sample size was kept relatively small.

The standard procedure for taking ladder interviews differs from the procedure used in this research since the indoor environment cannot be considered as a usual product. In product marketing or consumer psychology, the interviewee gets the opportunity to physically use and touch the different products. This is not possible for this research because the aim is to determine how an indoor environment should be designed according to the needs of building occupants. For this reason, pictures were used to represent the different components of the indoor environment. To reduce possible effects, the photo collages were composed carefully and show a wide variety of possible systems and properties and respondents were always free to ask for more information about a certain picture if necessary. Moreover, research done by Reynolds and Gutman [1998] states that respondents start the ladder interviews in correspondence to the properties which are considered most important. This information supports the suitability of pictures as alternative for physical presence of a product.

The categorization of the attributes, consequences and values is very determinative for the results of both the correspondence analysis and the meaning structure analysis. If the categories were chosen more broad, more details are lost. If the categories were chosen more specifically, some results were not mentioned often enough to be included in the HVM and the correspondence analysis would give even more widely spread results.

The results from this research contribute to a first step towards a holistic approach to the design of the indoor environment. The results support the importance of psychological aspects in the indoor environment. Even more than half of the properties which are mentioned by respondents have a psychological nature. Furthermore, the usage of the means-end chain theory has proven to be successful in the context of the indoor environment.

References

- Antonovsky, A., 1979, *Health, Stress and Coping*. San Fransisco: Jossey-Bass Publishers.
- BellBond, J.T., Galinsky, E., 2006, How can employers increase the productivity and retention of entry-level, hourly employees?, Families and Work Institute, November 2006.
- Breda, A.D. van, 2001, Resilience theory: A literature review, Report MPI/R/104/12/1/4, dd October 2001, South African Military Health Service, Military Psychological Institute, Social Work Research & Development, Pretoria
- Dilani, A., 2008, Psychosocially supportive design; A salutogenic approach to the design of the physical environment', *World Health Design*, July 2008.
- Gutman J., 1982, A means-end chain model based on consumer categorization processes, *Journal of Marketing* 46: 60-72.
- Huisman E.R.C.M., Morales E., Hoof J. van, Kort H.S.M., 2012, Healing environment :A review of the impact of physical environmental factors on users, *Building and Environment* 58: 70-80
- Reynolds, T.J., Gutman, J., 1998, Laddering theory, method, analysis and interpretation, *Journal of Advertising Research* March 1988.
- Reynolds, T.J., Olson, J.C., 2001, *Understanding consumer decision making*, New Jersey: Lawrence Erlbaum Associates.

- Rothmann, S., Venter, M., 2010, Sense of coherence, locus of control and self-efficacy as predictors of job satisfaction', *International Journal of Psychology* 35: 293-293
- Strümpfer, D.J.W., Bruin, G.P. de, 2009, Antonovsky's sense of coherence and job satisfaction: Meta-analysis of South African data', *SA Journal of Industrial Psychology/SA Tydskrif vir Bedryfsielkunde* 35: 767.
- Veitch, J.A., Charles, K.E., Farley, K.M.J., Newsham, G.R., 2007, A model of satisfaction with open-plan office conditions: COPE field findings, *Journal of Environmental Psychology* 27(3): 177-189.
- Vischer, J.C., 2007, The effects of the physical environment on job performance: towards a theoretical model of workspace stress, *Stress and Health* 23: 175-184.
- World Health Organization (WHO), 1948, Preamble to the Constitution of the World Health Organization as adopted by the International Health Conference, New York, April 1948.
- Yamazaki, Y., Togari, T., Sakano, J, 2011, Toward Development of Intervention Methods for Strengthening the Sense of Coherence: Suggestions from Japan', *Asian perspectives and evidence on health promotion and education*: 118-132.

Cost effectiveness of thermal mitigation based on the long term thermal analysis of a large office building

A. Merlino¹, S. Viazzo², D. Freda³, P. Capone³, M. Del Gaudio⁴, P. Lenzuni⁵

¹ Cesnir Consultancy, Milan, Italy

² Technical consultant, Vercelli, Italy

³ Italian National Workers' Compensation Authority, Rome Research Unit, Italy

⁴ Italian National Workers' Compensation Authority, Avellino Research Unit, Italy

⁵ Italian National Workers' Compensation Authority, Florence Research Unit, Italy

Abstract

Multi-storey steel-and-glass office buildings suffer from a strong thermal load during the summertime, particularly in Mediterranean countries, and thermal discomfort is a very likely occurrence, even when a massive air conditioning centralized system is operated. Significant departures from thermal comfort conditions have been proven to result in decreased performance for office workers, which translates into a additional costs for the employer.

In this work we initially use the results of an extensive measurement campaign to characterize the overall summer comfort, using long term descriptors which also integrate a method to select the appropriate thermal quality class for each environment. We then simulate the change in the thermal environment produced by the use of solar control films, a very simple and low cost thermal mitigation action, and calculate the associated thermal-induced increase in performance. Finally, we estimate the costs and benefits so that the cost-effectiveness of such an action is calculated. Results show that the fractional discomfort time (PMV outside the -0.5 to 0.5 range) is 15 – 20% at best and can grow up to 70 – 80% in specific rooms. Performance improvements up to 1.5% can be achieved. Although this figure may look unimpressive, the implied cost to benefit ratio is nonetheless very small (1/8 to 1/3 – that is benefits exceed costs by a factor 3 to 8). Considerations based on economics as well as general well being of employees strongly recommend the adoption of solar control films or similar technical improvements.

Keywords

Long term thermal comfort, cost effectiveness

1. Introduction

Many multi-storey steel-and-glass office buildings were built in Italy during the 60's and the 70's with limited if any consideration of energy savings technologies and thermal comfort issues. Because of the presence of single glazed glass and the absence of any insulating layer, these

buildings suffer from a strong thermal load during the summertime, particularly in Mediterranean countries. Although the general sensitivity to thermal comfort issues is much higher today, the limited budget typically allocated for thermal mitigation actions poses strong limitation to the introduction of technological elements for comfort improvements. It is therefore of primary importance to have reliable estimates of costs/benefits ratios for several different options, in order to make a sensible decision. However, while costs are usually straightforward to calculate, benefits can be much harder to quantify.

Purpose of the study

This paper's objective is twofold:

a) to complete a thorough assessment of the current thermal state of a large office building. To this aim, the statistical distribution of PMV is discussed, several long-term discomfort indexes are calculated for the whole summer, and a criterion is established for the selection of the one which is most adequate to predict work productivity.

b) to determine costs and benefits of a very simple thermal mitigation action. To this aim, simulations are carried out to predict the thermal impact of improving existing window glasses with solar control films. Costs and benefits are calculated, the latter taking into account the higher performance of employees.

2. Method

The target of our investigation is a large, five-storey office building located in a flat area near Milan, Italy. The building has a latin cross shape, with its major axis roughly aligned in the N-S direction. Figure 1 provides a sketchy map of the building's third floor where most measurements have been performed. Measurement sites are marked with red dots.

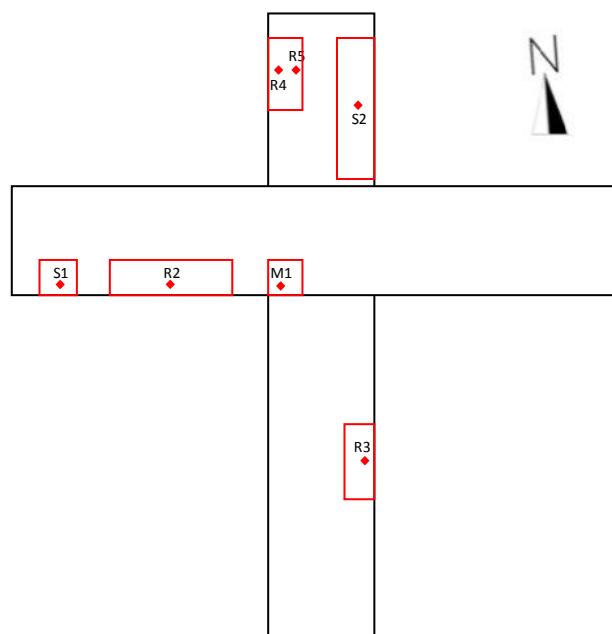

Figure 1 – Map of the building's 3rd floor. Investigated rooms marked with red lines; measurement sites marked with red dots.

Measurements have been carried out in nine different locations inside eight different rooms. Measurement sites have been selected in order to collect a sample which is representative of the thermal variability occurring in the building, with respect to a) orientation, b) floor; c) position within a given room, in descending order. All tested rooms are multiple offices, with areas between 35 and 300 m². The maximum (theoretical) number of occupants in each room, taken equal to the number of workstations, ranges between 5 and 73. Table I provides a synthesis of all tested locations, including the relevant room, its size, orientation and the number of employees.

Position ID	Room ID	Orientation	Floor	Floor area (m ²)	Window area (m ²)	Number of employees
M1	01	S-W	3	45.1	22.54	10
R1	02	S	1	121.6	33.81	18
R2	03	S	3	300.9	90.16	45
R3	04	E	3	36.5	11.27	5
R4	05	W	3	121.7	33.81	30
R5	05	W	3	121.7	33.81	30
S1	06	S	3	54.7	11.27	9
S2	07	E	3	360.4	101.43	73
S3	08	E	2	150.3	33.81	20

Table I – Synthesis of measurements

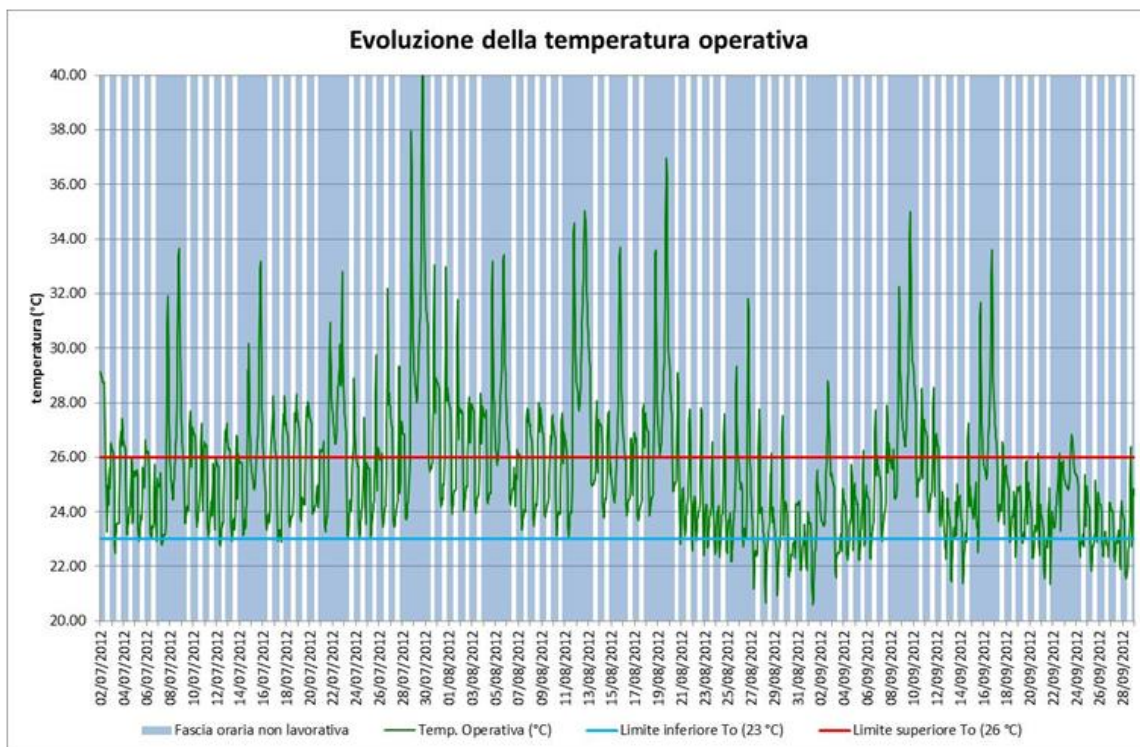

Figure 2 – Operative temperature as a function of time

Simultaneous measurements of the environmental quantities relevant to thermal comfort (air temperature and relative humidity, air velocity, globe temperature) have been carried out using a set of dedicated sensors remotely connected to a data logger. All instrumentation is commercialized by LSI-LASTEM [1]. Measurements have been taken non-stop for the 10 weeks from July 2 to September 7, 2012. Some data were eventually discarded after scrutiny for possible instrumental malfunctions. After averaging all data over consecutive 15 minute periods, and discarding data outside office work hours (9 am to 6 pm), a total of 1850 datasets resulted. The full summer time evolution of the operative temperature at the position R4 is shown in Figure 2. Vertical white lines mark working days. Besides four very warm days between the end of July and the beginning of August, which also include the highest operative temperature recorded ($t_{o-max} = 33^{\circ}\text{C}$), the systematic occurrence of temperatures around 28°C is a clear indication of strong and consistent discomfort.

3. Results

Long term comfort

In the building targeted by our investigation employees are engaged in office work. Calculations of PMV have accordingly been carried out assuming the same metabolic activity of 1 met and the same clothing thermal insulation of 0.5 clo for all employees in all office rooms at all times. The value of 0.5 clo is very similar to that found in an extensive experimental survey carried out in a few southern Italy office building, both with and without air conditioning [2]. The time history of PMV has been synthesized in a single value, representative of long term summer comfort (LTC = Long Term Comfort), using method C and method D as detailed in Appendix H of the ISO 7730 standard [3]. According to method C we have

$$\text{LTC}_C = \sum_j \text{wf}_j \times t_j \quad (1a)$$

where t is time in [h]. As for the weighting factor wf , the following rules apply:

- $\text{wf} = 1$ if $\text{PPD} < \text{PPD}_{lim}$
- $\text{wf} = \text{PPD}/\text{PPD}_{lim}$ otherwise

In order to improve its “readability”, LTC has been scaled in this paper to give a dimensionless value

$$\text{LTC}^*_C = \frac{\sum_j \text{wf}_j \times t_j}{\sum_j t_j} \quad (1b)$$

According to method D, LTC is the simple arithmetic mean of all PPD values

$$\text{LTC}_D = \frac{\sum_j \text{PPD}_j \times t_j}{\sum_j t_j} \quad (2)$$

LTC_C has dimensions [h], whereas both LTC^*_C and LTC_D are dimensionless.

Thermal quality class

Calculation of LTC_C and LTC^*_C requires that PPD_{lim} is known. ISO 7730 provides three different values of PPD_{lim} (6% – 10% – 15%) according to the quality class which is adopted in the comfort assessment, but fails to include any method to identify the correct quality class. In this work the quality class has been found using a method [4] that takes into account:

1. the individual thermal sensitivity (function of age);
2. the accuracy of the task to be performed;
3. the practicality of thermal technical manipulation

ranked according to relevance. Each of the three factors is quantified by a score F_i on a 0 to 10 scale. The overall score F is found using the algorithm

$$F = \prod_i F_i^{p_i} \quad (3)$$

where $p_1 = 5/3$, $p_2 = 4/3$ and $p_3 = 1$. Two thresholds exist that separate Class A ($F > 3000$), from Class B ($500 < F < 3000$) from Class C ($F < 500$) environments. In the case under consideration, we set $F_1 = 5$ (healthy adult individual) $F_2 = 8$ (mentally demanding task) and $F_3 = 5$ (no structural constraints to air-conditioning devices). Equation (3) then gives an overall score $F = 1260$ which in turn implies that all the environments which are targeted in this study belong in Class B, with summer comfort limits for acceptability $\text{PMV}_{\text{lim}} = 0.5$ and $\text{PPD}_{\text{lim}} = 10\%$.

Position ID	PMV_{min}	PMV_{max}	LTC[*]_C	LTC_D	\bar{P}
M1	-1.36	2.46	1.36	11.81	0.991
R1	-0.15	1.31	1.24	11.20	0.982
R2	-0.06	2.06	1.95	18.93	0.977
R3	-0.88	1.94	1.49	12.25	0.985
R4	-1.60	2.68	1.48	13.07	0.991
R5	-0.73	2.42	1.10	8.26	0.990
S1	-0.74	2.19	2.06	19.58	0.977
S2	-0.43	1.57	1.42	12.06	0.982
S3	-0.26	1.76	1.89	18.20	0.977

Table II – Summary of thermal comfort and productivity

The long term comfort descriptors LTC_C^* and LTC_D have been calculated for each measurement point, and results are shown in Table II, along with the highest and lowest value of PMV found during the office hours.

Thermal comfort and productivity

Thermal discomfort is well known to have a significant impact on both physical and mental performance, including workplace productivity [5]. In order to estimate the productivity change due to thermal factors, we use the relationship found by Jensen et al. [6]

$$RP = -0.0069 \times tsv^2 - 0.0123 \times tsv + 0.9945 \quad (4)$$

This relationship links the relative productivity (RP) for office tasks to the thermal sensation vote “tsv”. This function has a maximum at $tsv = -0.9$, which agrees with other study indicating that optimal performance is achieved with slightly below comfort temperatures [7].

The focus of this paper is on integrated summer productivity. This quantity is readily calculated from the detailed time evolution of productivity. In order to calculate the latter, it has to be recognized that each value of PMV resulting from our experimental field measurements is the weighted mean of various thermal sensation voted cast by different individuals [3]. This “biological diversity” is well approximated by a normal distribution with a standard deviation of 0.75 tsv units. Accordingly, each value of PMV has been used to generate a distribution of thermal sensation votes, and RP at any generic time t_k has been calculated as a weighed mean

$$P(t_k) = \frac{\sum_j P_j (tsv_j) \times w_j}{\sum_j w_j} \quad (5)$$

where individual weights are given by the fractional abundance of subjects casting the thermal sensation vote tsv_j . Once the productivity has been calculated at any given time t_k , the time-integrated summer productivity is the simple arithmetic mean over the K time slots

$$\bar{P} = \frac{\sum_{k=1}^K P(t_k)}{K} \quad (6)$$

Values of \bar{P} are shown in the last column of Table II.

4. Discussion

The current thermal environment 1: Probability distributions of PMV

The probability density function of PMV values is roughly normal in environments where deviations from comfort are of minor relevance (eg, room S2, Figure 3a), whereas it shows a more significant bimodality in environments where deviations from comfort are larger (eg. Room S1, Figure 3b). Using two normal distributions very good fits are usually achieved, with rms departures on each point of order 4×10^{-3} to 6×10^{-3} , three to five times better than using a single normal distribution. In three out of nine points the fraction of measurements resulting in PMV within the appropriate acceptability range $[-0.5 +0.5]$ is below 30%; this fraction is between 50 and 60% in four points and greater than 70% in just two points (Figure 4).

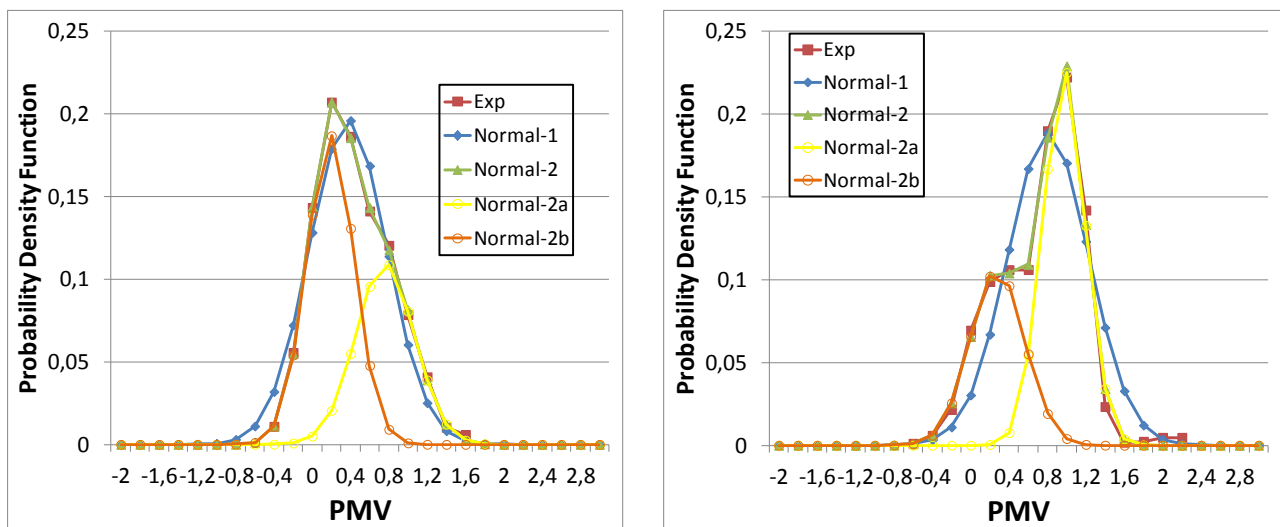

Figure 3 – Probability Density Function of PMV – a) Room S2 – b) Room S1
Blue: One normal distribution – Green: cumulated two normal distributions – Orange and Yellow: individual components of two normal distributions

The PMV value requested to cumulate 95% of measurements (hereafter $PMV_{95\%}$) ranges between 0.6 and 1.5, and is shown in Figure 5. In line with statistical arguments which assign particular significance to the 95% fraction, we think that $PMV_{95\%}$ is a suitable indicator of long-term discomfort. With respect to the identification of a possible limit of acceptability for $PMV_{95\%}$, the only real constraint is that it cannot be lower than 0.5, which is the limit set by ISO 7730 (Class B), and usually applied to thermal comfort assessment on short timescales.

Figure 5 shows that results fall into one of two classes: five measurement sites (R2, R3, S1 S2 and S3) have $PMV_{95\%}$ well above 1; in the remaining four sites (M1, R1 R4 and R5) $PMV_{95\%}$ ranges between 0.65 and 0.83. We use these findings to set a tentative limit of acceptability around the median of the lower range, that is $PMV_{95\%} = 0.75$. This is 1.5 times the relevant comfort limit set by ISO 7730 for Class B environments. Admittedly, this is presently little more than a guess, since results of this study are not necessarily representative of the whole class of large office buildings. Neither can we prove that some of the thermal environments evaluated in this study can indeed be deemed acceptable. This said, it is our perception that if the limit is set so low that all rooms become thermally unacceptable (below 0.65 in this case), there is very limited chance that

any real mitigation action will be implemented. In the opposite extreme, if limit is set too high, comfort would be compromised to an unacceptable degree. Any meaningful limit should be established balancing comfort and practicality.

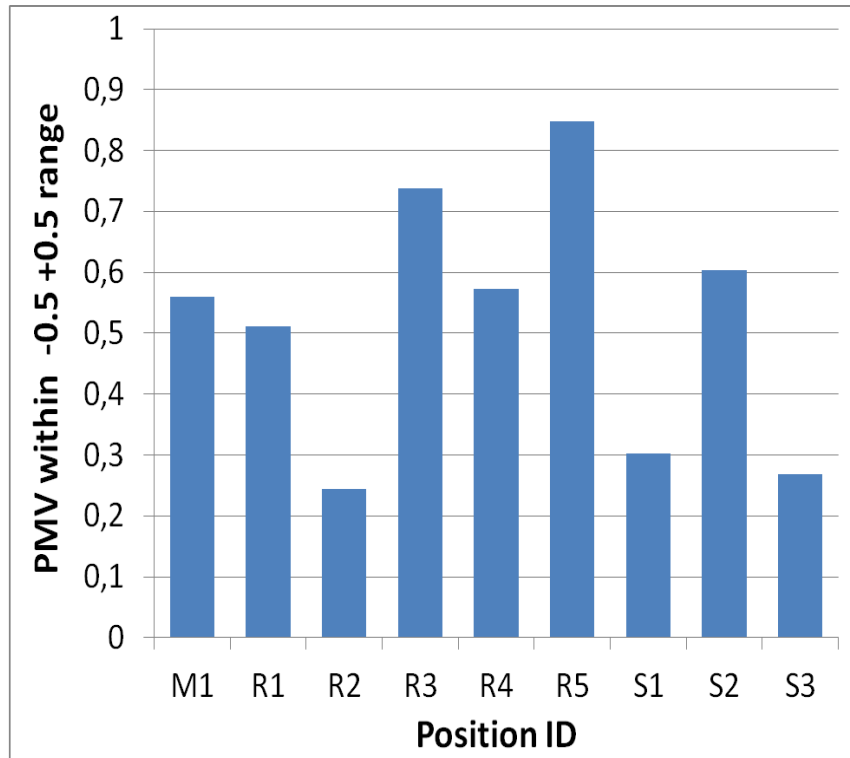

Figure 4 – Fraction of measurements with PMV inside the acceptability range

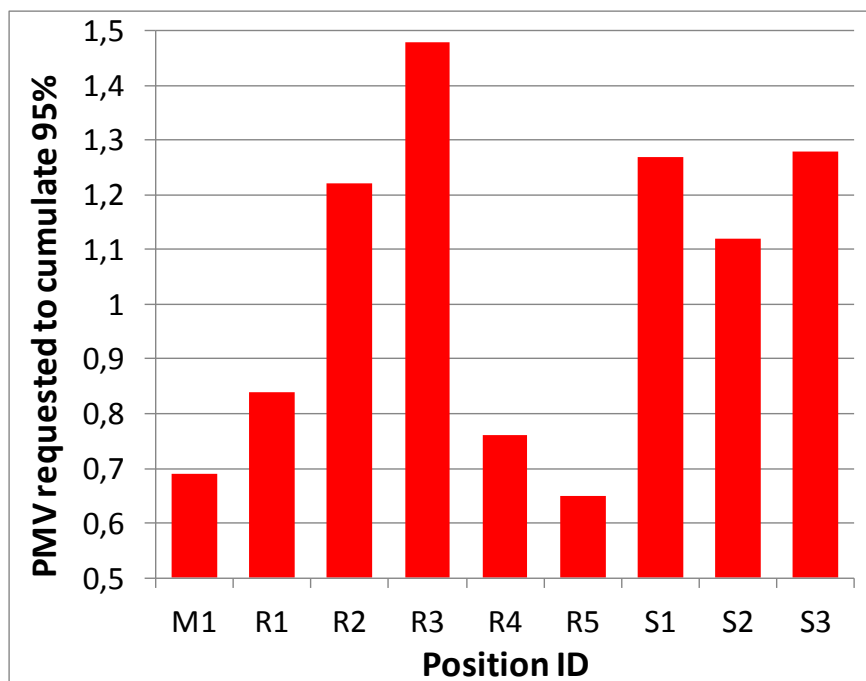

Figure 5 – 95th percentile of the cumulated PMV distribution

The current thermal environment 2: Correlation of LTC indexes with productivity

The correlation of LTC^*_C and LTC_D with \bar{P} is almost identical ($r^2 = 0.66$ vs. 0.69). Both are adequate estimate of long term comfort in the context that we are exploring in this paper. Figure 6 shows productivity as a function of LTC^*_C . Figure 7 shows the integrated (relative) productivity calculated as detailed in the previous section.

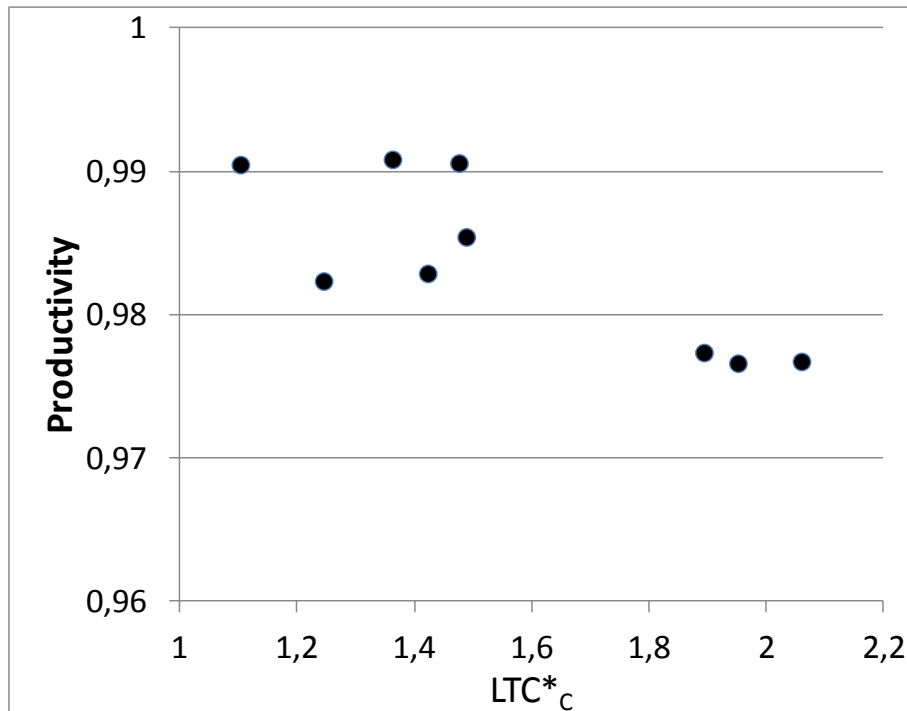

Figure 6 – Integrated productivity vs. LTC^*_C

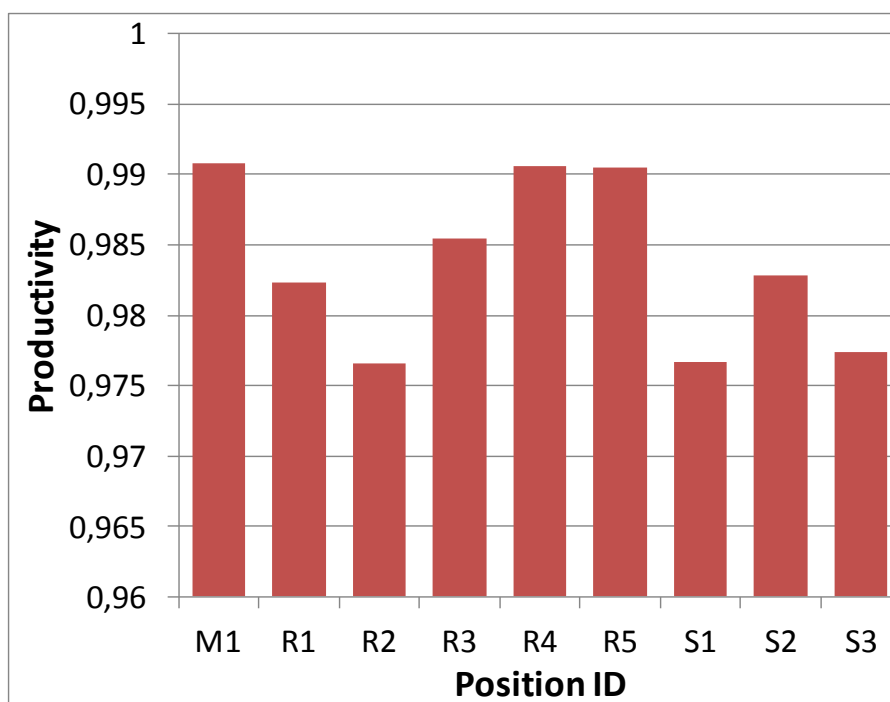

Figure 7 – Integrated productivity for the different measurement points

Thermal mitigation actions

The building air-conditioning system provides a total airflow of 240000 m³/h. Summer set point temperatures are 22 – 26°C, with a relative humidity of 50%. The system is periodically inspected and either found compliant to relevant standard or fixed to achieve compliance. However, summer thermal comfort in the building has been found to be generally poor and sometimes very poor (see Figure 4 and Figure 5). Because of a combination of warmer summer conditions, technical obsolescence and a layout which has been repeatedly changed over the years, the air-conditioning system is today clearly inadequate even if correctly operated. Further upgrading the air-conditioning equipment is a costly option. Several cheaper and more eco-friendly alternatives are available.

In this paper we consider a very simple mitigation action, consisting in laying out a solar control film upon the existing window glass. Solar control films, also known as heat rejection films, can be directly applied to the interior of single glass windows to reduce the amount of infrared, visible light, and ultraviolet radiation entering windows. Such films convert incoming solar radiation to infrared radiation, which is then rejected back through the glass to the exterior. More sophisticated and effective solar control systems are available. However they are usually much more expensive (solar control glass) and their implementation often implies significant structural work (external shields / brise soleil). It is extremely unlikely that such devices will be adopted on a large scale required in building of this size, given the implied time, costs and hassle. On the opposite, the low cost, easy and fast installation, and minimal invasiveness of solar control films make it more likely to be perceived as acceptable even by firms with a low sensitivity to this topic.

Here we assume a polyester film with sputtered treatment, having solar factor (g-value) equal to 0.34, shading coefficient equal to 0.39, visible light transmittance equal to 0.34, visible light reflection equal to 0.24 and total fraction of solar energy rejected of 66%. While films with better solar control properties are commercially available, their visible light transmittance is too poor and unsuitable for offices. From a technical standpoint, this film guarantees a good compromise between low thermal conductivity and good transparency to visual radiation. Overall, when considering also its moderate cost, it represents a good option in those cases where substantial improvement can be expected even with simple devices, and no strict requirements on the thermal and visual environments exist.

Predictions of the thermal improvements induced by this solar control film have been made using the software STEP (Summer Thermal Environment Performance). Simulations have been run for three measurement points, R2 R4 S2, where the window surface faces south, west and east respectively. New (lower) values of the indoor temperature and the radiant temperature have been predicted for the full summer period. Once a new value of t_a is known, a new value of RH has been calculated, by keeping the absolute humidity constant. Every other parameter kept constant, a new value of PMV has been calculated. Finally, application of equations (5) and (6) has led to a new (higher) value of productivity associated to the improved thermal comfort.

Both costs and benefits have both been calculated per capita and per year. Costs have been calculated by dividing the full cost (raw materials + labor cost) of solar control films in each room, by the average number of employees working in the room and by the predicted lifetime of the film.

The film cost has been estimated at 60 € per m² of window surface. The average number of employees has been set at 2/3 of the official value shown in Table I. The value of 2/3 has been estimated considering that employees are routinely displaced to work in other locations both in Italy and abroad, for extended periods of time which we estimate at roughly 1/3 of their total work load.

A conservative film lifetime of five years has been assumed. The economic benefit deriving from the improved thermal comfort has been calculated by multiplying the productivity fractional gain $\Delta P/P$ by the per-capita gross income of the work force in the building and by the film fractional effective time, that is the time of the year over which it provides thermal benefits. We adopt for the gross income a figure of 65000 €/year [8], while the fractional effective time is conservatively estimated equal to the fractional time spanned by our investigation, which gives 10 weeks/1 year = 0.19. Table III summarizes the outcome of the simulations: values of the long term comfort index LTC^*_C before (subscript-1) and after (subscript-2) the implementation of the thermal mitigation actions are shown in columns 2 and 3. Integrated productivity gains are shown in column 4, benefits in column 5, and costs in column 6. Finally, the cost to benefit ratio C/B is shown in column 7.

Position ID	LTC^*_{C-1}	LTC^*_{C-2}	$\Delta \bar{P}$	Benefits (€)	Costs (€)	C/B
R2	1.95	1.17	0.0153	191	24	0.125
R4	1.48	1.61	0.0037	46	16	0.344
S2	1.42	1.04	0.0072	90	18	0.203

Table III – Synthesis of thermal comfort improvements and cost to benefit ratios associated to the use of solar control films

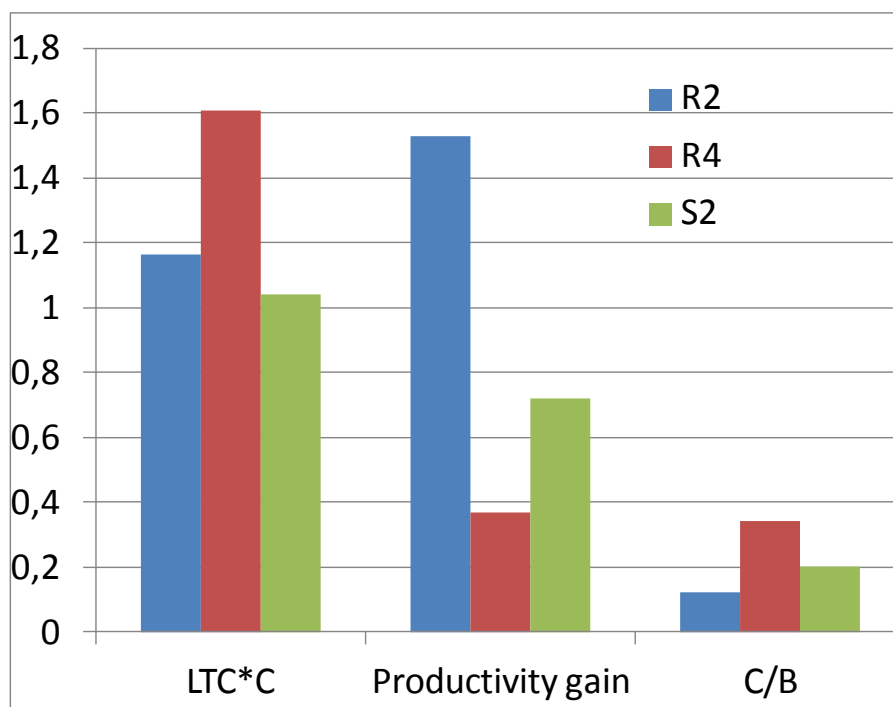

Figure 8 – Long term comfort, productivity gain (×100) and cost to benefit ratio

It is fair to say that estimates of both costs and benefits are quite uncertain: uncertainty on costs derives from the wide variety of solar control films which are commercialized and the poorly known average number of employees in any given room. Uncertainty on benefits is mostly associated to the uncertain estimate of the per-capita gross income of the employees working in this building. This said, the huge mismatch between costs and benefits leaves little room for debate over the meaningfulness of this type of thermal mitigation action. With benefits exceeding costs by factors 3 – 8 (Table III, column 7), the solar films pays for itself in 1/8 to 1/3 of its predicted lifetime, that is, on average, just one summer. Given this very short time, a thorough assessment of the economic impact of the operation should be feasible already at the end of the year immediately following installation, providing direct and relatively quick proof of the achieved benefits. The largest productivity increase is not surprisingly obtained in the south-facing room R2, while the effect is smallest in west-facing room R4 (Figure 8). The fact that a small but positive productivity change is accompanied in R4 by a higher value of LTC*C (higher discomfort) is due to the fact that productivity has a maximum at PMV \cong -0.9, so that comfort and productivity are not always strictly correlated.

Finally, some extra thermal benefit will undoubtedly be achieved even before (May, June) and after (September) the two months investigated in this work. A tentative estimate has been performed calculating first the total number of “degree-hours”

$$f = \sum_{h=1}^H (t_{out} - t_{neutr}) \quad (7)$$

for each month, and then taking the ratio

$$F = \frac{f_{May} + f_{Sep} + f_{Oct}}{f_{Jul} + f_{Aug}} \quad (8)$$

In equation (7), t_{out} is the outdoor temperature, t_{neutr} the neutral temperature below which no benefit is expected. The sum is carried out over the total number of office hours in a month H, and includes only non negative terms. Values of F range between 0.40 and 0.32 for neutral temperatures t_{neutr} between 24°C and 26°C. Taking into account this extra benefit would therefore imply a further 25% decrease in the cost/benefit ratio.

5. Conclusions

Widespread summer thermal discomfort is the rule, not the exception in large office buildings, at least in Italy. Built in the 60’s or in the early 70’s with little or no awareness of energy savings concepts, they have been taken into the 21st century virtually untouched. The growing sensitivity to thermal comfort issues has been handled just by overloading air conditioning systems,

with large costs and dubious benefits. This is clearly demonstrated by the extensive whole-summer experimental campaign presented in this paper. Long term comfort indexes show that at most 1/3 of offices have thermal conditions at the edge of thermal acceptability. In most rooms limits are exceeded more than 50% of the time, with PMV values extending up to, and sometimes exceeding 1.5 – *this is with the air conditioning system in operation*. In this paper we show that a small but significant productivity increase can be achieved with the adoption of even the most simple-minded and low cost thermal mitigation action (solar control films). Although the mere consideration of arguments related to the workers' comfort should already be sufficient to trigger thermal control actions, the additional force of economic arguments presented here might provide that extra push need to overcome the reluctance to invest time and money into any energy saving technology.

References

- [1] <http://www.lsi-lastem.it/ItemsByCategory.aspx?CategoryID=12>
- [2] Fato, I, Martellotta, F, Chiancarella, C Thermal Comfort in the Climatic Conditions of Southern Italy, ASHRAE Transactions 2004; 110 (2): 578–593.
- [3] ISO 7730, Ergonomics of the thermal environment - Analytical determination and interpretation of thermal comfort using calculation of the PMV and PPD indices and local thermal comfort criteria. International Organization for Standardization, Geneva, Switzerland, 2005.
- [4] Lenzuni, P, Freda, D, del Gaudio, M Classification of thermal environments for comfort assessment. Ann Occup Hyg 2009; 53 (4): 325–332.
- [5] Hancock, PA, Vasmatsidis, I Effects of heat stress on cognitive performance: the current state of knowledge. Int. J. Hyperthermia 2003; 19 (3): 355–372.
- [6] Jensen, KL, Toftum, J, Friis-Hansen, P A Bayesian Network approach to the evaluation of building design and its consequences for employee performance and operational costs, Building and Environment 2009; 44:456–462.
- [7] Seppänen, O, Fisk, WJ, Lei, QH Effect of temperature on task performance in office environment. Lawrence Berkeley National Laboratory 2006; Publication 60946.
- [8] Wargocki, P, Andersson, J, Boerstra, A, Clements-Croome D, Fitzner, K, et al. In: Wargocki, P, Seppänen, O, (editors), Indoor climate and productivity in offices - how to integrate productivity in life-cycle cost analysis of building services, REHVA Guidebook 6. Finland:Rehva, 2006.

Choosing a method of thermal comfort for mixed-mode office buildings located in hot-humid summer climate

Ricardo Forgiarini Rupp and EneDir Ghisi

Laboratory of Energy Efficiency in Buildings, Department of Civil Engineering, Federal University of Santa Catarina, Florianópolis-SC, Brazil. Email: ricardorupp@gmail.com; enedir@labeee.ufsc.br

Abstract

The objective of this paper is to assess methods of thermal comfort for use in mixed-mode office buildings located in hot-humid summer climate based on air-conditioning consumption of a predominant typology of real mixed-mode office buildings. Three methods to assess thermal comfort were analysed: (1) Givoni's chart for hot and humid climates, (2) ASHRAE 55-2010 for determining acceptable thermal conditions in occupied spaces, (3) ASHRAE 55-2010 for determining acceptable thermal conditions in naturally ventilated spaces. Different models of mixed-mode office rooms in two solar orientations and three window areas per model were analysed. Simulations were performed using the EnergyPlus computer programme. Thermal comfort was assessed applying the simulations output data into the upper acceptable ranges of each method. This work provides a way to choose a method of thermal comfort for mixed-mode office buildings that could be used where subjective assessment of thermal comfort is not available.

Keywords: Thermal comfort, mixed-mode buildings, hybrid ventilation.

1 Introduction

Nowadays there are two main lines of thought concerning thermal comfort: The steady-state model (PMV-PPD method), based on Fanger's studies (Fanger, 1970; Fanger and Toftum, 2002) and the adaptive model based on the works of Auliciems (1981), de Dear, Brager and Cooper (1997) and Nicol and Humphreys (2002). The PMV-PPD method suits well to occupants' thermal sensation in buildings with air-conditioning whereas the adaptive method describes thermal sensation of users more appropriately in naturally ventilated buildings (Fanger and Toftum, 2002; Cao et al., 2011; Deuble and de Dear, 2012).

For mixed-mode buildings a thermal comfort method is not available and more studies are required to prove that a specific method is really necessary. de Dear and Brager (2002) suggested that the ASHRAE Standard 55 (2010) method for determining acceptable thermal conditions in naturally ventilated spaces could be used in buildings operating with mixed-mode ventilation: when the maximum limits of acceptability are reached the air-conditioning is turned on just to lower the temperatures to the acceptability limit; the building operates with natural ventilation while the interior temperatures are within the limits of acceptability.

Deuble and de Dear (2012) studied a mixed-mode building in Sydney, Australia. The mixed-mode ventilation operated automatically changing from natural ventilation to air-conditioning when the indoor temperature was higher than 25°C. Once in air-conditioning the system maintained the indoor temperature at 24°C±0.5°C. Measurements of environmental variables were performed at the same time that thermal comfort questionnaires were applied. The

results indicated that more people were dissatisfied with their thermal environment during air-conditioning operation than during natural ventilation. The perception of the occupants changed as the building changed from natural ventilation to air-conditioning: a PMV = +1 was felt by users as much warmer than neutral in comparison with the same thermal environment during natural ventilation. Deuble and de Dear (2012) also concluded that during natural ventilation operation the adaptive method corresponded well with occupants' comfort and during air-conditioning operation the PMV-PPD model best described user's thermal sensations.

Brager and Baker (2008) compared the thermal comfort data of 12 mixed-mode commercial buildings with the data of 358 air-conditioned commercial buildings. The data are from a database created by the Center for the Built Environment, University of California, USA. These data were obtained through assessments of occupants' satisfaction with their workspace using a 7-point scale ranging from very satisfied (+3) to very dissatisfied (-3), with a neutral midpoint (0). The authors concluded that, on average, the performance of mixed-mode buildings (concerning thermal comfort) is significantly better than the other 358 air-conditioned buildings.

Classical thermal comfort field studies relating outdoor and indoor environmental variables, user's garment and metabolism with subjective assessments of thermal comfort present more valuable information than climate chamber experiments or simulation studies because field studies deal with real people in their real workplace. However, it is not always possible to perform this kind of research due to the lack of resources (researchers, funds or time). Thus, an existing method of thermal comfort could be helpful to describe in which conditions users would likely feel comfortable. But what method of thermal comfort should we use for mixed-mode buildings when subjective assessments of thermal comfort are not available?

The objective of this paper is to assess methods of thermal comfort for use in mixed-mode office buildings located in hot-humid summer climate based on air-conditioning energy consumption of a predominant typology of real mixed-mode office buildings. This work is a continuation of a previous work (Rupp and Ghisi, 2014). In that paper we considered the methods in its original publication format and we do not evaluate the prevailing mean outdoor air temperature as presented in Addendum C - ASHRAE 55 (2010). In this paper, we also evaluate the behaviour of a humidity limit for the ASHRAE 55 (2010) method for determining acceptable thermal conditions in naturally ventilated spaces.

2 Method

The research is based on computer simulations performed using EnergyPlus 6.0 programme and air-conditioning energy consumption of a predominant typology of real mixed-mode office building in Florianópolis city, Brazil. The TRY (Test Reference Year) climate file of Florianópolis (LabEEE, 2011) was used for the simulations. Room models of mixed-mode office buildings located in hot and humid summer climate were simulated under two modes of natural ventilation: single-side ventilation and cross-ventilation. For each mode of ventilation, results were analysed using different methods to assess thermal comfort, considering only the heat discomfort limits imposed by such methods. No air-conditioning simulations were performed, as they are not necessary for this study.

More detailed information about parameters and considerations of simulation can be found in Rupp and Ghisi (2014).

2.1 The climatic context and the simulation models of mixed-mode office buildings

Florianópolis is an island located in the state of Santa Catarina, southern Brazil (latitude - 27°36' and longitude -48°33'). The city is warm and humid during summer (December to March) as shown in Fig.1. High air humidity is common due to the proximity to the sea.

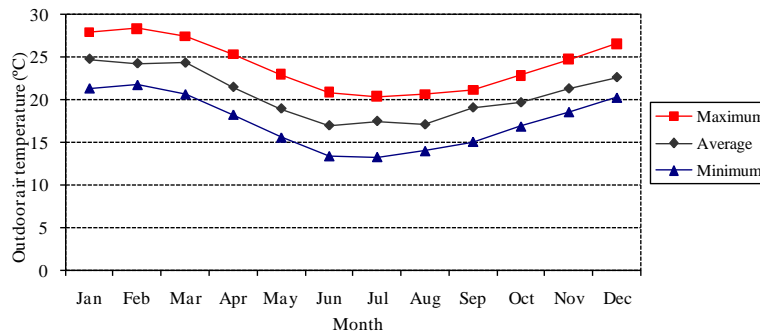

(a)

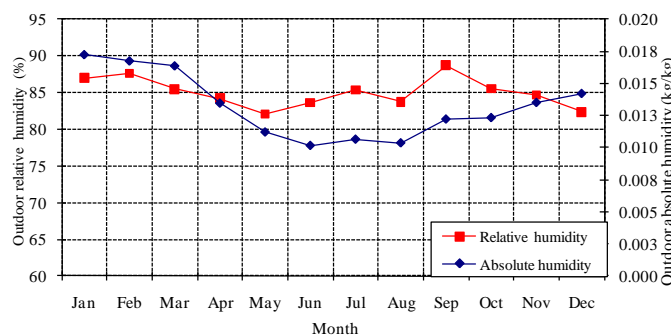

(b)

Figure 1. (a) Maximum, minimum and average outdoor air temperature and (b) outdoor air relative humidity and average outdoor air absolute humidity throughout the year in Florianópolis. Source: based on Brasil (1992).

This climate context conducts to the highest use of air-conditioning for buildings' cooling in summer. In other periods of the year the air-conditioning is less used or turned off. Heating is not commonly used (Santana, 2006). Thus, mixed-mode buildings are usually found in Florianópolis.

For this study, different models of mixed-mode office rooms were considered to have adiabatic ceiling, floor and interior walls, because what is under assessment is the behaviour of a single model (cell) and not the whole building. The sizes of the models were based on the room index (Equation 1), as used in manuals of illumination and in Ghisi (2002). The working surface was taken as 0.75m above floor level and the overall height of the models as 2.80m.

$$K = \frac{W \cdot D}{(W + D) \cdot h} \tag{Eq. 1}$$

where K is the room index (non-dimensional); W is the overall width of the room (m), D is the overall depth of the room (m) and h is the mounting height between the working surface and the ceiling (m).

Models with geometries (Width:Depth) of 2:1 and 1:2, two room sizes per geometry (room indices of 0.8 and 5.0), two solar orientations (south and west) and three window areas (10, 50 and 100%) per room model were analysed. The window area is the total area of the façade that can be glazed. The window is located below a 60cm beam and has the width of the façade. The room dimensions for each room index and geometry can be seen in Table 1.

Table 1. Mixed-mode office room dimensions for each room index and geometry.

Room index - K	Geometry - Width:Depth			
	2:1		1:2	
	Width (m)	Depth (m)	Width (m)	Depth (m)
0.8	4.92	2.46	2.46	4.92
5.0	30.75	15.38	15.38	30.75

The models operated with artificial light and typical office equipment and occupancy, resulting in the internal thermal loads presented in Table 2. These loads were considered during occupation of the building (8am – 6pm, Monday to Friday).

Table 2. Internal thermal loads.

Room index - K	0.8	5.0	Source
Lighting Power Density (W/m ²)	13.9	8.1	lighting design performed by the authors
Occupation (m ² /person)	14.7		Santana, 2006
Metabolic activity (W/m ²)	65		ASHRAE 55, 2010
Equipment (W/m ²)	9.7		Santana, 2006

The buildings components (Table 3) were based on Santana's work (2006), with windows composed of single glass, 6mm, 88% of light transmission.

Table 3. Properties of the building components.

Element	Material	Roughness	Conductivity (W/m.K)	Density (kg/m ³)	Specific heat (J/kg.K)	Thickness (m)	Total thickness (m)
Walls	Plastering mortar	rough	1.15	2000	1000	0.025	0.200
	Ceramic 6-hole brick	rough	0.90	1600	920	0.150	
	Plastering mortar	rough	1.15	2000	1000	0.025	
Floor	Concrete slab	rough	1.75	2200	1000	0.150	0.185
	Plastering mortar	rough	1.15	2000	1000	0.025	
	Ceramic floor	rough	0.90	1600	920	0.010	
Ceiling	Ceramic floor	rough	0.90	1600	920	0.010	0.185
	Plastering mortar	rough	1.15	2000	1000	0.025	
	Concrete slab	rough	1.75	2200	1000	0.150	
Door	Wood	smooth	0.15	614	2300	0.030	0.030

2.2 Natural ventilation simulation

The multi-zone Airflow Network model from EnergyPlus was used for the simulation of natural ventilation. The simulations were performed for each room model, in pairs, according to Fig. 2. There is a door measuring 0.9 x 2.2m separating the rooms. Model 1 is used for the North-South orientations and Model 2 for the East-West orientations.

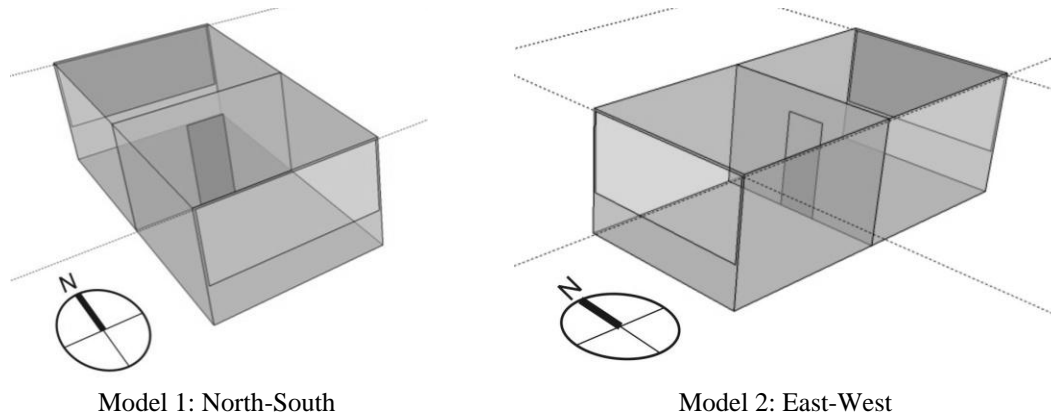

Figure 2. Examples of simulation models of natural ventilation.

The windows were considered operable and the natural ventilation control strategy adopted was based on temperature. In EnergyPlus this means that the windows were opened when three requirements were fulfilled: (1) the zone temperature was greater than the outdoor temperature, (2) the zone temperature was greater than the setpoint temperature of natural ventilation and (3) the schedule control of natural ventilation allowed ventilation. The setpoint temperatures for natural ventilation were 22°C (autumn and winter, from March 21 to September 20) and 20°C (spring and summer, from September 21 to March 20). The schedule control of natural ventilation allows ventilation from Monday to Friday. Two modes of natural ventilation were simulated throughout the simulation period: single-sided ventilation (the interior door was closed) and cross-ventilation (the interior door was opened).

For each simulation, outdoor and indoor environmental variables were obtained on an hourly basis throughout the year.

2.3 Methods to assess thermal comfort

Three methods to assess thermal comfort were analysed: (1) Givoni's chart (Givoni, 1992) for hot and humid climates (Fig. 3), (2) ASHRAE 55 (2010) for determining acceptable thermal conditions in occupied spaces (Fig. 4), (3) ASHRAE 55 (2010) for determining acceptable thermal conditions in naturally ventilated spaces (Fig. 5). Method 3 was assessed considering the 80% and 90% upper acceptable temperature threshold (Eq. 2 and Eq. 3) and also: (3-i) the outdoor mean monthly air temperature (original publication), (3-ii) the prevailing mean outdoor air temperature (daily temperature 7-days ago) (Addendum C - ASHRAE 55, 2010), (3-iii) the outdoor mean monthly air temperature with a suggested 80% limit of relative humidity and (3-iv) the prevailing mean outdoor air temperature (daily temperature 7-days ago) with a suggested 80% limit of relative humidity. The proposal of a relative humidity threshold was based on results of the mentioned previous work (Rupp and Ghisi, 2014) and on the work of Emmerich, Polidoro and Axley (2011).

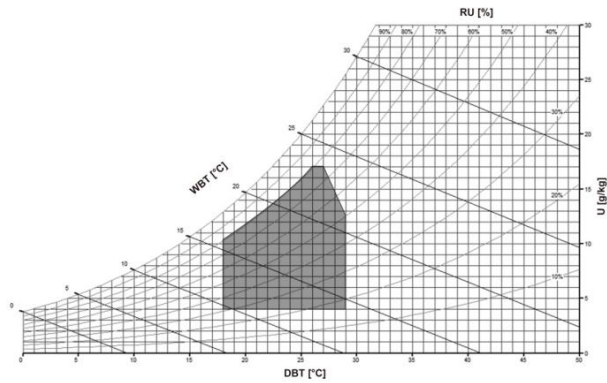

Figure 3. Givoni's chart for hot and humid climates marking the thermal comfort zone. DBT=dry bulb temperature; WBT=wet bulb temperature; RU=relative humidity; U=humidity. Based on Givoni, 1992.

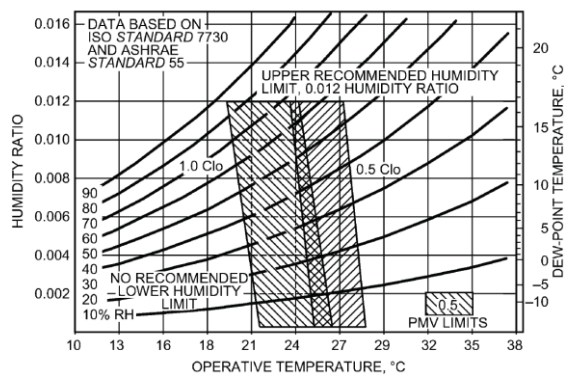

Figure 4. Acceptable range of operative temperature and humidity for spaces. Source: ASHRAE Handbook Fundamentals, 2009.

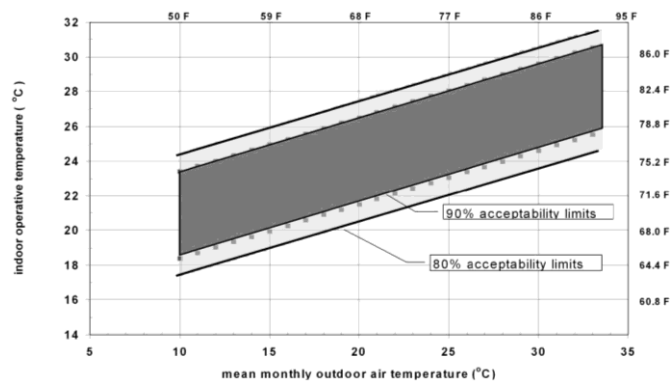

Figure 5. Acceptable operative temperature ranges (80% and 90%) for naturally ventilated spaces. Source: ASHRAE 55, 2010.

$$\text{Upper 80\% acceptable temperature limit (}^{\circ}\text{C)} = 0.31 t_{a(\text{out})} + 21.3 \quad \text{Eq. 2}$$

$$\text{Upper 90\% acceptable temperature limit (}^{\circ}\text{C)} = 0.31 t_{a(\text{out})} + 20.3 \quad \text{Eq. 3}$$

where $t_{a(out)}$ is the mean monthly outdoor air temperature used for 3-i and 3-iii; on a daily basis $t_{a(out)}$ was replaced with $t_{pma(out)}$, which is the prevailing mean outdoor air temperature (daily temperature 7-days ago) for 3-ii and 3-iv.

The prevailing mean outdoor air temperature (daily temperature 7-days ago) was calculated as presented in de Dear (2006) and de Dear and Candido (2010), Eq. 4:

$$t_{pma(out)} = 0.34t_{od-1} + 0.23t_{od-2} + 0.16t_{od-3} + 0.11t_{od-4} + 0.08t_{od-5} + 0.05t_{od-6} + 0.03t_{od-7} \quad \text{Eq. 4}$$

where t_{od-1} is the mean daily outdoor temperature from the previous day, t_{od-2} is the mean daily outdoor temperature from the day before that, and so forth.

2.4 Number of hours of heat discomfort

The results of simulations of natural ventilation were applied in each method to assess thermal comfort. Thus, it was possible to determine the number of hours of heat discomfort throughout the year for each method. This number of hours represents the number of hours per year that the use of air-conditioning (in cooling mode) is necessary to bring thermal comfort to the users. The number of hours was compared among each evaluation method. Graphs with the number of hours for each method and for the same room were developed to ease the comparison.

2.5 Correlations

Correlations between the total number of hours in the year in which the air-conditioning will be necessary, and the number of hours of use of air-conditioning of the predominant typology of office building in Florianópolis, as defined by Santana (2006), were performed. Santana (2006) defined a predominant typology from an analysis of 35 real mixed-mode office buildings located in Florianópolis. Her analyses were performed in relation to the constructive characterization and to the occupation pattern and equipment use. Through simulation of such predominant typology in EnergyPlus, Santana (2006) obtained the air-conditioning energy consumption throughout the year (Fig. 6).

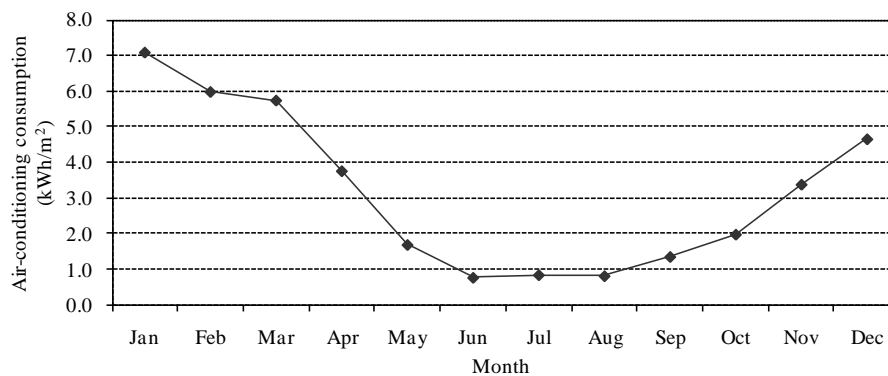

Figure 6. Air-conditioning energy consumption of the predominant typology of office buildings in Florianópolis. Based on Santana, 2006.

From the EnergyPlus file of the predominant typology of office buildings of Santana's study (2006) we obtained the number of hours of air-conditioning use on an hourly basis. Thus, we performed correlations between the number of hours of air-conditioning use obtained from the three methods and the number of hours of air-conditioning use of the predominant

typology of office buildings in Florianópolis and the results were shown in graphs. The bisection was also drawn in each of these graphs in order to consider the real behaviour of air-conditioning use. Thus, methods with results above the bisector consume more air-conditioning electricity than a typical office building in Florianópolis and may not be adequate to be used with the mixed-mode ventilation strategy. On the other hand, methods with results below the bisector consume less air-conditioning electricity than a typical office building in Florianópolis and are more adequate to be used with the mixed-mode ventilation strategy.

The decision on the most adequate method to assess thermal comfort to be used in mixed-mode office buildings was made from such comparisons and from the pattern of air-conditioning use, as defined by Santana (2006). The highest use of air-conditioning for cooling office buildings located in Florianópolis occurs from December to March, and there is scarcely any use from June to August (Santana, 2006).

3 Results

3.1 Number of hours of heat discomfort of the predominant typology of mixed-mode buildings

The number of hours of the predominant typology of mixed-mode office buildings located in Florianópolis, calculated using the EnergyPlus file of Santana (2006) is presented in Fig. 7. Even in winter, there are hot days with high solar radiation, resulting in the use of the air-conditioning for cooling. The greatest number of hours of air-conditioning use occurs between January and March. From March on, the number of hours decreases, being slightly above zero between June and August. Between August and December there is a gradual increase in the number of hours.

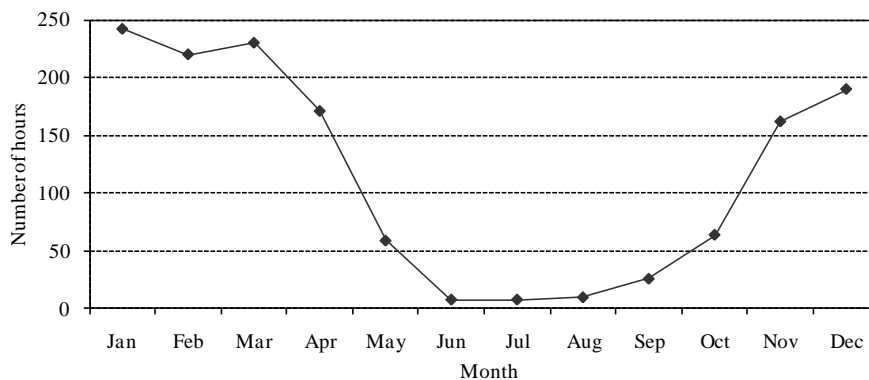

Figure 7. Number of hours per month of use of air-conditioning calculated for the predominant typology of mixed-mode office buildings. Based on Santana, 2006.

3.2 Number of hours of heat discomfort calculated by the different thermal comfort methods

Monthly results of the sums of the number of hours of heat discomfort for one geometry, one room index, three window areas, two orientations, with single-sided ventilation, by the methods of Givoni, ASHRAE 55 for occupied spaces (ASHRAE 80%), ASHRAE 55 for naturally ventilated spaces (using the outdoor mean monthly air temperature) with 80% of acceptability (ASHRAE NV 80%) and with 90% of acceptability (ASHRAE NV 90%), ASHRAE 55 for naturally ventilated spaces (using the outdoor mean monthly air temperature with the proposal of relative humidity threshold) with 80% of acceptability (ASHRAE NV

80_RH_limit) and with 90% of acceptability (ASHRAE NV 90_RH_limit), ASHRAE 55 for naturally ventilated spaces (using the prevailing mean outdoor air temperature) with 80% of acceptability (ASHRAE NV 80_Tpma) and with 90% of acceptability (ASHRAE NV 90_Tpma), ASHRAE 55 for naturally ventilated spaces (using the prevailing mean outdoor air temperature with the proposal of relative humidity threshold) with 80% of acceptability (ASHRAE NV 80_Tpma_RH_limit) and with 90% of acceptability (ASHRAE NV 90_Tpma_RH_limit), can be seen in Fig. 8.

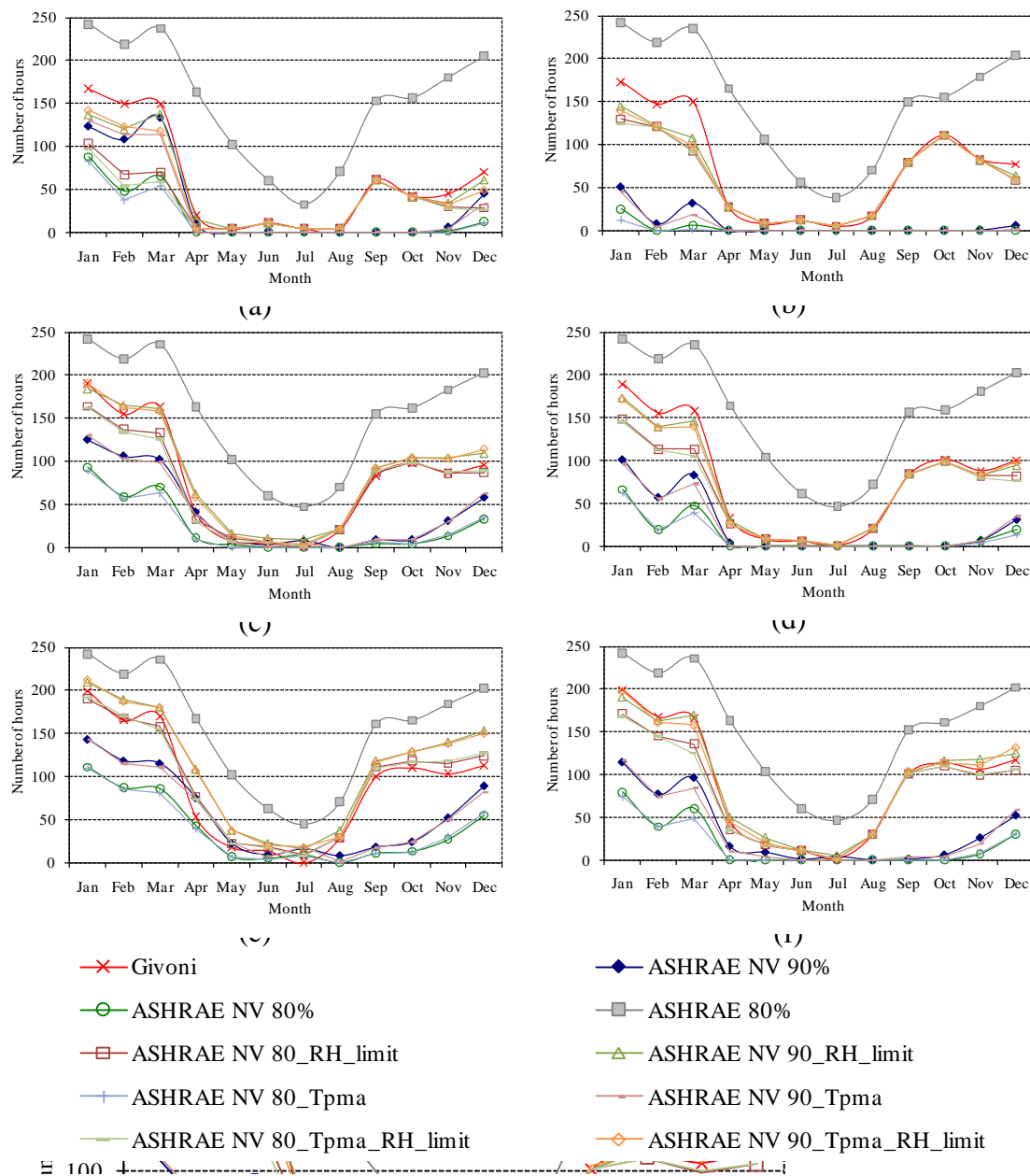

Figure 8. Number of hours of heat discomfort for the model with single-sided ventilation, geometry of 2:1, room index equal to 0.8, west and south orientations and window areas of 10, 50 and 100%. (a) West orientation, 10% of window area; (b) South orientation, 10% of window area; (c) West orientation, 50% of window area; (d) South orientation, 50% of window area; (e) West orientation, 100% of window area; (f) South orientation, 100% of window area.

Comparing the monthly number of hours of heat discomfort with the pattern of air-conditioning use in Florianópolis (Fig. 7) some statements may be pointed out: (a) the trends obtained for the method of ASHRAE 55 for occupied spaces are different from the pattern of air-conditioning use in Florianópolis during winter (June to August); (b) the trends obtained for the other methods are similar to the pattern of air-conditioning use in Florianópolis (with some exceptions among the methods); (c) the number of hours obtained for the method of ASHRAE 55 for naturally ventilated spaces (90% of acceptability) and Givoni were similar; even for models with cross-ventilation; (d) the number of hours obtained for the method of ASHRAE 55 for naturally ventilated spaces using the outdoor mean monthly temperature and the prevailing mean temperature are similar with each other, with the first leading to slightly greater number of hours.

The number of hours of heat discomfort along the year was also obtained for all models, for each method to assess thermal comfort, with single-sided ventilation (Table 4) and cross-ventilation (Table 5). In general, the number of hours is greater for models with room index equal to 5.0 than for room index equal to 0.8. As for Givoni's and ASHRAE 55 for naturally ventilated spaces (with the proposal humidity limit) methods, the opposite trend was observed in some situations. Another factor is that the increase of window area increases the internal thermal load of the room. Thus, the awaited trend is that there would be a greater number of hours of air-conditioning use (more hours of heat discomfort). However, for some cases in the method of ASHRAE 55 for naturally ventilated spaces (original publication) this trend was observed, but for other cases the opposite pattern occurred (the number of hours decreased).

The increase in the window area did not significantly affect the number of hours of heat discomfort for the method of ASHRAE 55 for occupied spaces. Furthermore, the number of hours per year obtained from the method of ASHRAE 55 for occupied spaces is much greater than the other methods, for all cases. This fact is due to the narrow limits established by this standard, to guarantee thermal comfort. Even in winter (June to August), due to high humidity, typical in Florianópolis, there would be a significant use of air-conditioning for cooling. This trend was the same for all models studied in this work. Thus, this method was considered not suitable to be applied to environments with high humidity and for the mixed-mode ventilation strategy studied in this paper.

The smallest number of hours were obtained for the method of ASHRAE 55 for naturally ventilated spaces (80% of acceptability, both with the outdoor mean monthly temperature and the prevailing mean temperature), followed by the same method with 90% of acceptability. By this method, in December, the number of hours of air-conditioning use was close to zero. Thus, the method of ASHRAE 55 for naturally ventilated spaces (80% and 90% of acceptability, both with the outdoor mean monthly temperature and the prevailing mean temperature) did not prove suitable for use in the climate of Florianópolis.

As a result, the methods of Givoni and ASHRAE 55 for naturally ventilated spaces with the proposal of humidity threshold remained to be assessed in detail. These methods showed a behaviour that met the pattern of use of air-conditioning in Florianópolis and are rather similar to each other. The following section will show another analysis to help choosing the method of thermal comfort for use in mixed-mode office buildings.

Table 4. Number of hours of use of air-conditioning throughout the year for each method to assess thermal comfort - interior door closed (single-sided ventilation).

Method	Comfort threshold based in	Window area	Geometry							
			1:2				2:1			
			K=0.8		K=5.0		K=0.8		K=5.0	
			West	South	West	South	West	South	West	South
			Number of hours with interior door closed							
ASHRAE NV 90%	Prevailing mean outdoor air temperature; Proposal of relative humidity threshold	10%	761	481	844	625	593	758	2062	543
		50%	798	726	793	625	1027	874	784	623
		100%	1068	917	769	651	1325	1085	970	792
ASHRAE NV 80%	Prevailing mean outdoor air temperature; Proposal of relative humidity threshold	10%	440	393	456	310	393	736	1519	432
		50%	625	611	436	330	851	762	516	437
		100%	877	811	533	490	1139	949	734	659
ASHRAE NV 90%	Prevailing mean outdoor air temperature	10%	735	165	804	564	394	68	2059	186
		50%	385	227	745	554	490	266	562	359
		100%	496	269	479	311	663	373	540	314
ASHRAE NV 80%	Prevailing mean outdoor air temperature	10%	405	35	413	242	183	13	1515	50
		50%	193	83	388	256	277	135	292	166
		100%	266	140	235	140	444	201	284	165
ASHRAE NV 90%	Outdoor mean monthly air temperature; Proposal of relative humidity threshold	10%	768	526	878	661	629	780	2053	584
		50%	825	744	819	669	1037	884	817	674
		100%	1075	929	799	689	1338	1106	983	827
ASHRAE NV 80%	Outdoor mean monthly air temperature; Proposal of relative humidity threshold	10%	475	417	495	367	427	743	1563	458
		50%	650	635	466	376	863	783	542	478
		100%	892	827	554	522	1139	961	763	677
ASHRAE NV 90%	Outdoor mean monthly air temperature	10%	741	217	839	600	425	98	2051	229
		50%	421	249	772	600	502	283	596	409
		100%	510	288	514	352	689	402	565	352
ASHRAE NV 80%	Outdoor mean monthly air temperature	10%	439	64	455	302	215	31	1559	81
		50%	219	108	418	302	290	157	318	207
		100%	283	158	257	171	454	215	315	182
ASHRAE 80%	Indoor operative temperature; Absolute humidity	10%	1840	1842	1863	1854	1820	1819	2093	1841
		50%	1840	1846	1851	1850	1842	1842	1848	1843
		100%	1842	1841	1844	1837	1858	1835	1845	1839
GIVONI	Indoor air temperature; Relative humidity	10%	782	683	809	743	727	890	1440	755
		50%	830	840	747	709	947	944	765	763
		100%	973	986	793	790	1074	1074	886	879

Table 5. Number of hours of use of air-conditioning throughout the year for each method to assess thermal comfort - interior door opened (cross-ventilation).

Method	Comfort threshold based in	Window area	Geometry							
			1:2				2:1			
			K=0.8		K=5.0		K=0.8		K=5.0	
			West	South	West	South	West	South	West	South
			Number of hours with interior door opened							
ASHRAE NV 90%	Prevailing mean outdoor air temperature; Proposal of relative humidity threshold	10%	529	660	822	539	724	894	1389	558
		50%	892	884	763	565	1070	963	808	612
		100%	1099	979	781	643	1321	1106	967	798
ASHRAE NV 80%	Prevailing mean outdoor air temperature; Proposal of relative humidity threshold	10%	419	635	434	279	636	877	917	452
		50%	781	799	435	319	908	874	528	439
		100%	915	873	542	496	1133	962	728	667
ASHRAE NV 90%	Prevailing mean outdoor air temperature	10%	173	62	780	461	150	51	1382	181
		50%	270	155	709	479	415	214	578	345
		100%	452	240	490	300	652	369	546	314
ASHRAE NV 80%	Prevailing mean outdoor air temperature	10%	41	1	389	197	49	4	907	54
		50%	135	49	381	227	224	107	293	166
		100%	234	111	243	143	431	193	286	168
ASHRAE NV 90%	Outdoor mean monthly air temperature; Proposal of relative humidity threshold	10%	575	684	852	584	753	909	1408	591
		50%	916	909	807	619	1076	982	833	662
		100%	1094	991	808	693	1332	1115	981	837
ASHRAE NV 80%	Outdoor mean monthly air temperature; Proposal of relative humidity threshold	10%	440	642	477	323	654	886	947	476
		50%	794	815	458	358	922	898	564	468
		100%	934	903	562	528	1137	975	757	686
ASHRAE NV 90%	Outdoor mean monthly air temperature	10%	228	98	812	506	185	73	1401	215
		50%	298	183	753	533	433	241	603	397
		100%	454	258	520	351	677	390	570	358
ASHRAE NV 80%	Outdoor mean monthly air temperature	10%	66	17	434	242	66	21	937	80
		50%	149	67	404	266	237	130	330	195
		100%	256	143	263	175	443	208	318	186
ASHRAE 80%	Indoor operative temperature; Absolute humidity	10%	1836	1832	1849	1846	1826	1821	1892	1842
		50%	1839	1831	1846	1849	1843	1833	1845	1845
		100%	1841	1835	1845	1843	1857	1827	1845	1838
GIVONI	Indoor air temperature; Relative humidity	10%	699	800	808	687	866	1006	1086	761
		50%	941	999	729	671	1011	1044	778	752
		100%	1017	1042	799	791	1075	1083	884	891

3.3 Correlations between the number of hours of heat discomfort of the predominant typology of mixed-mode buildings and the calculated number of hours

The number of hours of air-conditioning use obtained from the three methods was also correlated with the number of hours of the predominant typology of office buildings located in Florianópolis, calculated using the EnergyPlus file of Santana (2006).

Fig. 9 shows the correlations for the models with single-sided ventilation, geometry of 2:1, room index equal to 0.8, west and south orientations and window areas of 10, 50 and 100%. Fig. 9 also contains the bisector. Based on such graphs, it was verified which method had results below (the method could be considered adequate) or above (the method is considered not adequate) the bisector.

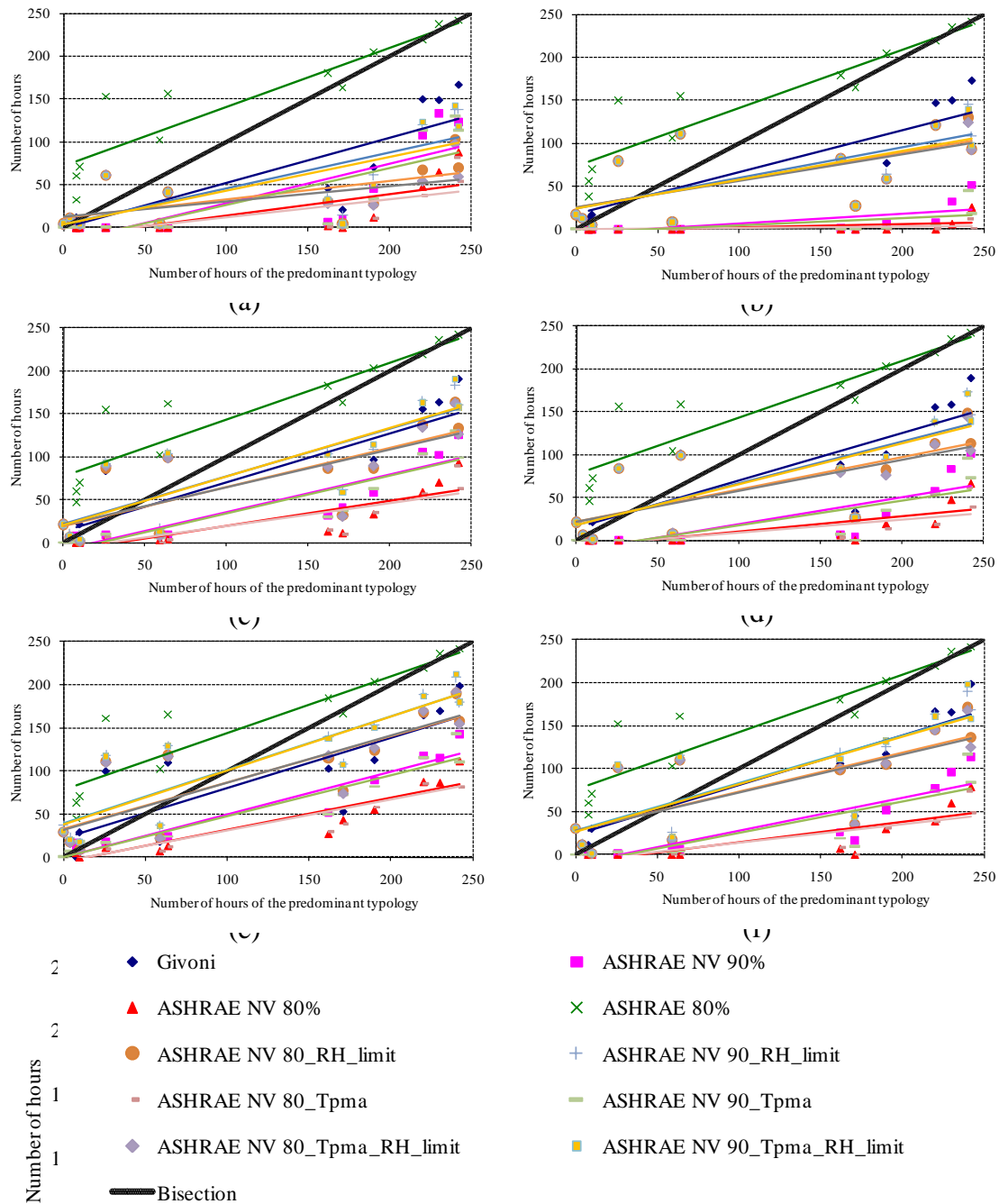

Figure 9. Correlation between number of hours of use of air-conditioning and the number of hours of use of air-conditioning estimated from the predominant typology of mixed-mode office buildings for the model with single-sided ventilation, geometry of 2:1, room index equal to 0.8, west and south orientations and window areas of 10, 50 and 100%. (a) West orientation, 10% of window area; (b) South orientation, 10% of window area; (c) West orientation, 50% of window area; (d) South orientation, 50% of window area; (e) West orientation, 100% of window area; (f) South orientation, 100% of window area.

The ASHRAE 55 method for naturally ventilated spaces (both 90% and 80% of acceptability, with the outdoor mean monthly temperature and the prevailing mean temperature) and the ASHRAE 55 method for occupied spaces were the ones with results more distant to the bisector in all cases. Thus, for the ASHRAE 55 method for naturally ventilated spaces (both 90% and 80% of acceptability, with the outdoor mean monthly temperature and the prevailing mean temperature), the straight lines always showed lower values than the values of the bisector, while for ASHRAE 55 method for occupied spaces, the straight lines always showed higher or equal values than those of the bisector.

In general, Givoni's method and the ASHRAE 55 90% of acceptability method for naturally ventilated spaces (both with the outdoor mean monthly temperature and the prevailing mean temperature, with the proposal of relative humidity limit) were the ones with results closer and below to the bisector for all cases with either single-sided ventilation or cross-ventilation. Such methods also presented the most consistent number of hours of heat discomfort compared to the pattern of air-conditioning use in Florianópolis. Therefore, these methods were considered the most appropriate to be used in climates similar to the one observed in Florianópolis, i.e., hot and humid summer climate.

4 Conclusions

This research provides a way to choose a method of thermal comfort for mixed-mode office buildings that could be used where subjective assessment of thermal comfort is not available. Furthermore, given that there is not a specific method to assess thermal comfort in mixed-mode office buildings, this work was carried out to help choosing a method of thermal comfort for such buildings located in hot and humid summer climates.

It can be concluded that the ASHRAE 55 method for occupied spaces is not suitable for application in mixed-mode office buildings located in hot and humid summer climates like observed in Florianópolis, due to the narrow humidity limits set by this standard to guarantee thermal comfort. These limits led to a significant and unrealistic use of air-conditioning for cooling in winter months. The ASHRAE 55 method for naturally ventilated spaces (both using the outdoor mean monthly temperature or the prevailing mean temperature) led to very low use of air-conditioning in December (summer), which is not consistent with the pattern of air-conditioning use observed in Florianópolis.

No big differences were found between the ASHRAE 55 method for naturally ventilated spaces using the outdoor mean monthly air temperature or the outdoor prevailing mean air temperature, when related to hours of heat discomfort. Nevertheless, the outdoor mean monthly air temperature showed a slightly greater number of hours.

Correlations between the number of hours of air-conditioning use obtained from the simulations and from the predominant typology of office buildings located in Florianópolis were performed for each method to assess thermal comfort. By comparing these correlations, it was concluded that the most suitable methods for use in hot and humid summer climates were the method of Givoni and the method of ASHRAE 55 with 90% of acceptability for naturally ventilated spaces (both with the outdoor mean monthly temperature and the prevailing mean temperature, with the proposal of relative humidity limit of 80%).

The results presented herein do not disprove the conclusions of our previous work (Rupp and Ghisi, 2014). In that paper, it was pointed out that the method of Givoni was the most suitable to be used in mixed-mode office buildings in the studied climate. In that paper we just considered the methods in their original publications. When proposing a relative humidity limit, the method of ASHRAE 55 with 90% of acceptability for naturally ventilated spaces

(both with the outdoor mean monthly temperature and the prevailing mean temperature) also could be considered suitable.

In the next step we will carry out a field research on thermal comfort to compare the results with the simulated ones.

Acknowledgements

Ricardo F. Rupp would like to thank CAPES – *Fundação Coordenação de Aperfeiçoamento de Pessoal de Nível Superior*, an agency of the Brazilian Government for post-graduate education, for the scholarship that allowed him to carry out this research. The authors also want to thank Marina V. Santana for supplying specific information about her research.

References

ASHRAE 55 (2010), Thermal environmental conditions for human occupancy. ASHRAE Standard 55-2010, Atlanta, Georgia, American Society of Heating, Refrigerating.

ASHRAE 55R (2010), Addendum c. American Society of Heating, Refrigerating and Airconditioning Engineers Inc. ASHRAE 55-2010.

ASHRAE Handbook Fundamentals (2009), Chapter 8: Thermal Comfort, American Society of Heating, Refrigerating and Air-Conditioning Engineers, Inc. Atlanta, 2004.

Auliciems, A (1981), Towards a Psycho-Physiological Model. *Int. J. Biometeor*, Vol. 25, No. 2, pp 109–122.

Brager, G and Baker, L (2008), Occupant satisfaction in mixed-mode buildings. *Proceedings of Conference: Air Conditioning and the Low Carbon Cooling Challenge*, Cumberland Lodge, Windsor, UK, pp 27-29.

BRASIL (1992), Climate Normals 1961-1990. Ministry of Agriculture and Agrarian Reform, National Secretary of Irrigation, National Department of Meteorology. Brasília, 1992 (in Portuguese).

Cao, B, Zhu, Y, Ouyang, Q, Zhou, X and Huang, L (2011), Field study of human thermal comfort and thermal adaptability during the summer and winter in Beijing. *Energy and Buildings*, Vol. 43, No. 5, pp 1051–1056.

de Dear, R and Brager, G (2002), Thermal comfort in naturally ventilated buildings: revisions to ASHRAE Standard 55. *Energy and Buildings*, Vol. 34, No. 6, pp 549-561.

de Dear, R, Brager, G and Cooper, D (1997), Developing an adaptive model of thermal comfort and preference. Final Report on RP 884. Sydney, Australia: Macquarie University.

de Dear, R.J (2006), Adaptive thermal comfort in building management and performance. *Proceedings of Healthy Buildings*, Lisbon Portugal.

de Dear, R.J and Candido, C (2010), An Adaptive Thermal Comfort Policy for a Geographically Dispersed Property Portfolio; Deciding When and Where to Air-Condition in a Warm Climate Zone. *Proceedings of 7th Windsor Conference*, Windsor, UK, 12-15 April 2010.

Deuble, M. P and de Dear, R.J (2012), Mixed-mode buildings: A double standard in occupants' comfort expectations. *Building and Environment*, Vol. 54, pp 53–60.

Emmerich, S.J, Polidoro, B and Axley, J.W (2011), Impact of adaptive thermal comfort on climatic suitability of natural ventilation in office buildings. *Energy and Buildings*, Vol. 43, No. 9, pp 2101-2107.

Fanger, P.O (1970), Thermal comfort. Danish Technical Press, Copenhagen, Denmark.

Fanger, P.O and Toftum, J (2002), Extension of the PMV model to non-air-conditioned buildings in warm climates. *Energy and Buildings*, Vol. 34, No. 6, pp 533–536.

Ghisi, E (2002), The use of fibre optics on energy efficient lighting in buildings. Ph.D. thesis, University of Leeds, Leeds, UK, 2002.

Givoni, B (1992), Comfort, Climate Analysis and Building Design Guidelines. *Energy and Buildings*, Vol. 18, No. 1, pp 11-23.

Laboratory of Energy Efficiency in Buildings (2011), Climate file of Florianópolis. Federal University of Santa Catarina. available at: <http://www.labeee.ufsc.br/>, accessed on 21 Feb. 2011 (in Portuguese).

Nicol, J. F and Humphreys, M (2002), Adaptive thermal comfort and sustainable thermal standards for buildings. *Energy and Buildings*, Vol. 34, No. 6, pp 563–572.

Rupp, R.F and Ghisi, E (2014), What is the most adequate method to assess thermal comfort in hybrid commercial buildings located in hot-humid summer climate? *Renewable and Sustainable Energy Reviews*, Vol. 29, pp 449–462.

Santana, M.V (2006), Influence of the constructive parameters on the energy consumption of office buildings located in Florianópolis-SC. Master's degree, Federal University of Santa Catarina, Florianópolis, Brasil, 2006 (in Portuguese).

Indoor thermal comfort survey in campus buildings (classrooms) in Beijing for a long time

Min Li¹, Bin Cao¹ and Yingxin Zhu¹

¹Department of Building Science, Tsinghua University, Beijing 100084, China, email limin464023719@163.com

Abstract

Beijing is in the Cold Climate Zone of China. This study carries out a long-term survey of indoor environmental parameters, the clothing of occupants, and the metabolic rate of occupants as well as people's voting of their sensation in classrooms in Beijing. The study was conducted in 2011 and 2012, trying to explore people's requirement of indoor thermal environment. Relationships between thermal parameters and people's sensations are found. The acceptable temperature range can meet the requirements of most of users. Also the clothing is an important factor influencing the occupants' sensation. A narrower range will make it more sensitive.

Keywords: Thermal comfort, Field study, Whole year, Classrooms, Adaption

1 Introduction

In recent years, as Chinese government has announced a series of strategies and policies of greatly promoting the environmental protection and energy conservation, building energy conservation is getting seriously attention. In such a situation, many universities want to make their campus "greener", so campus construction energy conservation work develops rapidly. For universities, it is important to make sure the campus construction can meet the requirements of teachers and students: learning, working or living comfortable and healthy. Meanwhile, universities need to play a leading and exemplary role in energy conservation and emissions reduction. For this purpose, it is very important to do the research which can find out what indoor environment conditions can meet the requirements of comfort and save much energy.

Previous field investigation for thermal comfort mostly aimed at a particular season (Wang et al, 2005; Cao et al, 2012; Lou et al, 2005; Li et al, 2007). In fact, human requirements for indoor thermal environment may vary in different seasons. The study of the relationship between the requirements and indoor environments in different

seasons is more important. There are some annual field investigations in the cold region (Wang et al, 2007), hot summer and cold winter region (Liu, 2007; Mao, 2007), hot summer and warm winter region (Chen et al, 2010; Zhang et al, 2010). Never less in the vast area of cold region, it is still rare.

To solve the above-mentioned two problems, we choose the classrooms and dormitories to carry out the thermal comfort field investigation work for a whole year. This article will mainly analyze the research results of campus buildings. The research about the dormitories will be discussed in another article.

2 Methodologies

2.1 Time and Place

The field study was conducted from September 2011 to August 2012, for 30 weeks (paused in holidays). The investigated places are classrooms in a university. There are four different rooms in this study which are similar designed for 30 users, shown in Fig. 1. Windows can be opened or shut down freely by the users. During autumn and spring, the classrooms are cooled down by the natural ventilation; in summer, there is no electric fan in the rooms, the rooms are cooled down by the central air-conditioning system; in winter, the rooms are warmed by the central air-conditioning system too. There are two controllers of the system in each room, the teacher or the administrator will set them before the classes. Respondents in classrooms were undergraduates.



Figure 1. Classrooms in this study

2.2 Information of Respondents

In order to avoid the effect of thermal adaptation caused by different regions, the respondents were all people who had lived in Beijing for long time and had adapted to the climate of Beijing well.

There are 66 respondents from two classes. The basic information of the respondents is in Table 1.

Table 1. Basic information of the respondents

Gender	Number	Age	Height(cm)	Weight(kg)
Male	31	21 ±3	173 ±10	64 ±11
Female	35	21 ±3	163 ±9	55 ±10

2.3 Instruments and Questionnaire

During each investigation, the environmental parameters were recorded while the respondents filled out all the contents of the questionnaires. The respondents were asked to fill the questionnaires at least once a week.

The indoor environment parameters including air temperature, mean radiant temperature, relative humidity and air velocity were measured by using the AM-101 PMV and PPD indices meter (Fig. 2). The accuracy of AM-101 is shown in Table 2. The parameters of the height of 1.1m were recorded. 1.1m is the height of head when people sit.



Figure 2. AM-101 PMV and PPD indices meter

Table 2. Accuracy of the AM-101 PMV and PPD indices meter

Parameter	Accuracy (Valid Range)
Temperature	$\pm 0.5^{\circ}\text{C}$ (15-35 $^{\circ}\text{C}$)
Relative Humidity	$\pm 3\%$ (20-80%)
Air Velocity	$\pm 0.1\text{m/s}$ (0-1m/s) $\pm 0.5\text{m/s}$ (1-5m/s)

The questionnaire consists of two parts: the basic information of respondents and their thermal votes. The basic information is about the activity and clothing of the respondents; thermal sensation is voted using ASHRAE seven-point scale, as shown in Fig. 3. In the research, 969 questionnaires are effective.

Your current thermal sensation is:
-3 clod; -2 cool; -1 slightly cool; 0 neutral; +1 slightly warm; +2 warm; +3 hot

Figure 3. The thermal sensation vote in the questionnaire

3 Results

3.1 Indoor Environment Parameters

The indoor environment parameters during this study are shown in table 3. There are the minimum, the maximum and the average value in the table. Indoor air velocity is very low. In most of the cases, it is lower than the human sensory threshold of 0.2 m/s. The average temperature and humidity in autumn, winter and spring are similar, while the ranges are different; temperature in summer is a little higher, ranges of

temperature and humidity are smaller.

Table 3. Indoor environment parameters

Season	Research period		Min.	Max.	Avg.
Autumn	2011-9-28~ 2011-10-28	Air Temperature(° C)	20.6	26.7	23.0
		Radiant Temperature(° C)	22.3	26.5	23.8
		Relative Humidity (%)	26.7	53.2	42.4
		Air Velocity (m/s)	0	0.2	0.1
Winter	2011-11-2~ 2012-3-31	Air Temperature(° C)	17.2	26.7	23.3
		Radiant Temperature(° C)	19.4	23.7	21.7
		Relative Humidity (%)	9.0	63.0	30.2
		Air Velocity (m/s)	0	0.2	0.1
Spring	2012-4-2~ 2012-4-27	Air Temperature(° C)	20.3	25.5	23.0
		Radiant Temperature(° C)	22.1	24.3	21.8
		Relative Humidity (%)	9.1	52.7	24.2
		Air Velocity (m/s)	0	0.4	0.1
Summer	2012-8-7~ 2012-8-13	Air Temperature(° C)	25.5	27.7	26.6
		Radiant Temperature(° C)	25.3	27.3	26.3
		Relative Humidity (%)	59.3	69.3	65.2
		Air Velocity (m/s)	0.1	0.2	0.2

3.2 Metabolic Rate and Clothing Insulation

In each survey, environmental parameters measurement lasted for a whole class (contains two section classes, 45 minutes each, 5 minutes break down in the middle). Respondents filled the questionnaires during the break, thus, we can ensure that the respondents had kept sitting for 45 minutes without eating before the questionnaires. According to the ASHRAE Handbook (ASHRAE, 2012), the metabolic rate of respondents was about 1.1 met.

During autumn and winter, clothing insulation of the respondents is between 0.5 clo to 1.3 clo. Difference between indoor and outdoor temperature is small in autumn, people reduce their dress when the indoor temperature is higher. Outdoor temperature is very low in winter, the respondents dress in long underwear, sweaters, trousers and etc. Some respondents still dress much indoor when the temperature indoor is higher. The temperature rise in spring, people no longer wearing a thick coat, clothing insulation reduced to 0.5 clo to 1.0 clo. In summer, both indoor and outdoor temperature is higher; respondents wear short sleeves, shorts or thin coat only, clothing insulation is 0.3 clo to 0.9 clo.

3.3 Relationships between Environment Parameters and Thermal Sensation Votes (TSV)

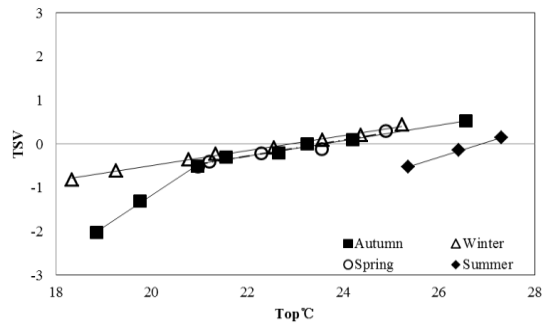

Figure 4. Relationships between operative temperature and TSV in different seasons

The relationships between operative temperature and TSV (average value) are shown in Fig. 4. According to GB/T 5701-2008 “indoor thermal environment conditions”, for the persons who engaged in activities in sit conditions, no direct sunlight and surrounding air velocity is not more than 0.2 m/s, the operative temperature equals to the average value of the air temperature and the radiant temperature. The regression function of the average TSV is as follows:

Autumn: $\text{top} < 21^{\circ}\text{C}$: $TSV = 0.7246t_{op} - 15.659 (R^2 = 0.9969)$

$\text{top} \geq 21^{\circ}\text{C}$: $TSV = 0.1775t_{op} - 4.176 (R^2 = 0.9846)$

Winter: $TSV = 0.172t_{op} - 3.9298 (R^2 = 0.9941)$

Spring: $TSV = 0.1838t_{op} - 4.3257 (R^2 = 0.9571)$

Summer: $TSV = 0.3416t_{op} - 9.1759 (R^2 = 0.999)$

The slopes of the regression function of autumn ($\text{top} \geq 21^{\circ}\text{C}$), winter and spring are similar, when $26^{\circ}\text{C} > \text{top} \geq 21^{\circ}\text{C}$, the function for spring and autumn are the same. The slope of the function in summer is greater than the other three seasons. This means that the respondents are more sensitive to the change of temperature in summer. The relationship between operating temperature and TSV in autumn can be divided into two segments, the turning point is the point of the operating temperature is about 21°C . The line slope is greater when the temperature is low, means that respondents are more sensitive to temperature change in low temperature, and we can see that the TSV are lower than that in winter. Then we can get the neutral temperature and the 90% acceptable temperature range. The data are shown in Table 4. Due to that in summer the highest temperature we get is 27.7°C , 0.5 of average TSV does not appear, so we can't get the upper limit of the acceptable temperature range, according to the function, the upper limit might be 28.3°C .

Table 4. The neutral temperature and the 90% acceptable temperature range

Season	The neutral temperature($^{\circ}\text{C}$)	The 90% acceptable temperature range ($^{\circ}\text{C}$) -0.5 < TSV < 0.5	The average value of the clothing insulation
Autumn	23.5	(20.7, 26.3)	0.85
Winter	22.9	(19.9, 25.8)	1.15

Season	The neutral temperature($^{\circ}$ C)	The 90% acceptable temperature range ($^{\circ}$ C) $-0.5 < TSV < 0.5$	The average value of the clothing insulation
Spring	23.5	(20.8,26.3)	0.79
Summer	26.9	(25.4,28.3)	0.42

4 Discussions

4.1 Clothing Insulation

According to the result of Table 4, the neutral temperatures are different between different seasons. The acceptable temperature ranges are different too. In winter, the neutral temperature is the lowest, and in summer it is the highest. In autumn and spring, the neutral temperatures are the same. The main reason of the different is the clothing insulation, Fig. 5 shows the clothing insulation of different seasons in every centigrade, the maximum and minimum values are shown. It is obvious that the insulation in winter is the largest, in summer it is the smallest.

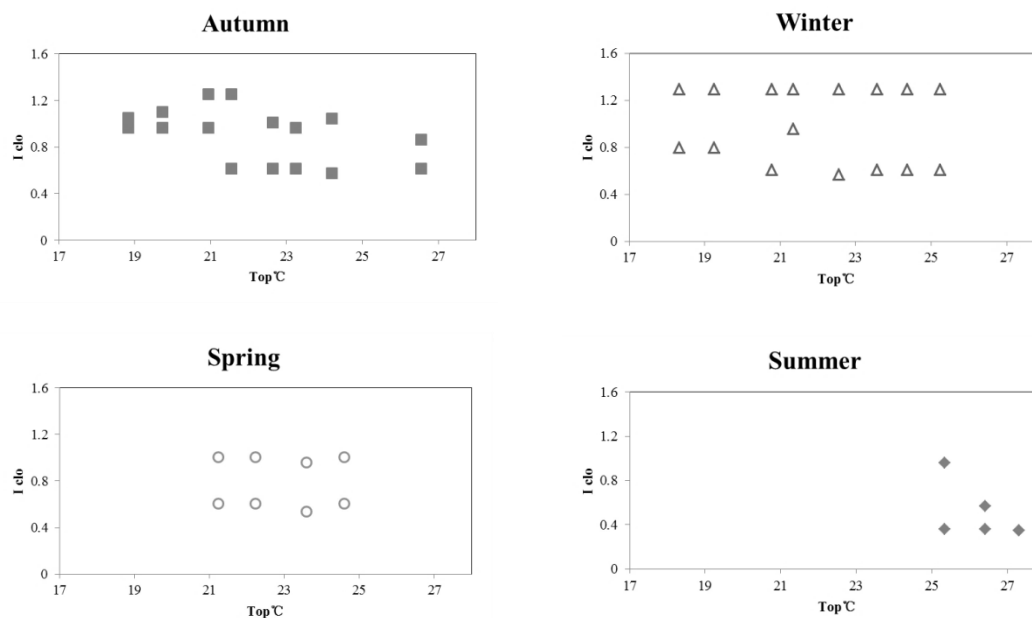

Figure 5. The Relationships between operative temperature and the clothing insulation in different seasons

The main reason for the highest neutral temperature in summer is that people dress less in summer. The adjustable range of the clothing is smaller so the respondents' ability of adapt to the temperature is weaker, so people are more sensitive to the temperature change and then the slope of the function is greater. The results also show that people are more sensitive to the temperature change when the temperature is low in autumn. Can we find the reason on clothing insulation change?

It is obvious shown in the Fig. 5, when the temperature is lower than 21 $^{\circ}$ C, the clothing insulation changed in autumn. The minimum values are much larger than the ones when the temperature is higher, while the maximum values are smaller, so the ranges of the insulation become narrower. In winter, the clothing insulation changed different from that in autumn. The maximum values are still, and the minimum values

are larger than the ones when the temperature is higher, but the difference is not that larger like that in autumn. So we can say that people in autumn have a weaker ability to change their cloth to adapt to the temperature change, this will be a main reason for they become more sensitive to the temperature change. In both autumn and winter, outdoor temperature is lower than that indoor. The maximum values of the clothing insulation were decided by the outdoor temperature. In winter, the outdoor temperature is lower, so the maximum values are larger; then, the minimum values will be decided by the indoor temperature, but at the same indoor temperature, respondents dress more in autumn than in winter. On the other hand, TSV in autumn are lower than that in winter, this means that the respondents feel colder in autumn than that in winter, so we can say that they have an adaption on cold in winter. Due to there is no condition of the low temperature appears in the spring, we can't ensure that whether the respondents still have the adaptation on cold in spring.

4.2 Natural Ventilation

We recorded the proportion of the opening windows (table 5), we can know that if the rooms were using natural ventilation.

Table 1. Percentage of the opening windows in different seasons

Season	Percentages of the opening windows
Autumn	33%
Winter	8%
Spring	33%
Summer	0%

As it is shown, during the spring and autumn, there was a higher percentage of opening windows, and the indoor air-conditioning system wasn't running at the same. Compared with the indoor temperature range and acceptable temperature range in table 3 and table 4, in the spring and autumn, natural ventilation can meet the requirements of the indoor thermal environment of respondents in these two seasons.

4.3 Neutral Temperature or Acceptable Temperature Range

In winter, we use central heating indoor, due to the individual differences, only 60% of respondents feel neutral (TSV=0) when the indoor temperature equals to the neutral temperature (shown in Fig. 6), 90% of the respondents' TSV are between -1 to 1 (acceptable temperature range means the temperature make the average TSV are between -0.5 to 0.5, but in this survey, respondents actually vote value as an integer, thus we use -1 and 1 to determine the acceptable range), the state of the indoor environment can meet the requirements of the respondents. When the temperature is extended to the acceptable temperature range, although only 53% of the respondents feel neutral, but there are still 90% of the respondents' TSV are between -1 to 1 (shown in Fig. 7), the state of the indoor environment can meet the requirements of the respondents.

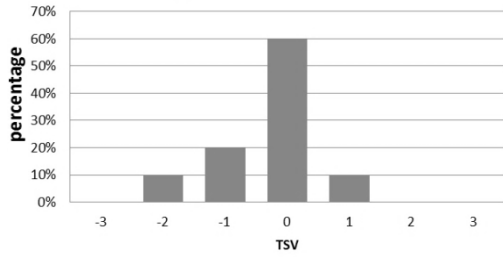

Figure 6. TSV at the neutral temperature in winter

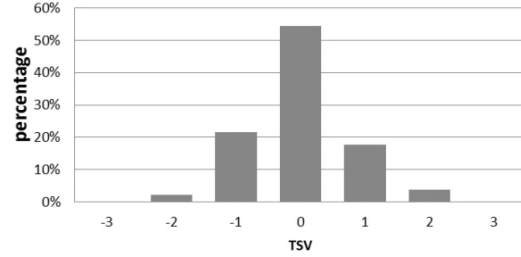

Figure 7. TSV at the acceptable temperature range in winter

The condition in summer is similar to that in winter (shown in Fig. 8 and Fig. 9). When indoor the temperature equals to the neutral temperature or between the acceptable temperature range (upper limit is the highest temperature in this research, the average TSV < 0.5), the requirements can be satisfied (more than 90% of the respondents' TSV located in [-1, 1]).

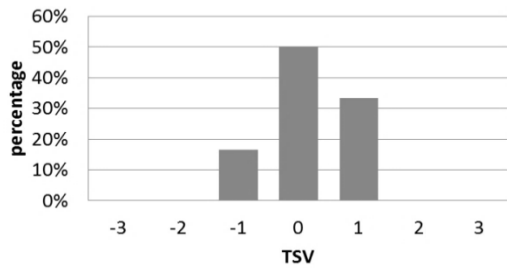

Figure 8. TSV at the neutral temperature in summer

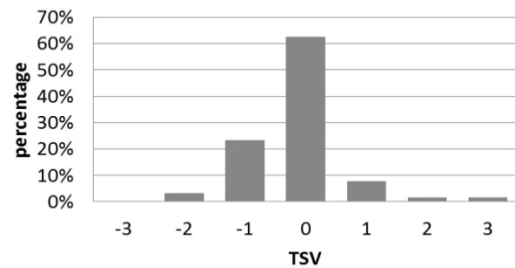

Figure 9. TSV at the acceptable temperature range in summer

Considering the demand for technology and energy to control the indoor temperature to a specific temperature point, we can consider to control the indoor temperature based on the accept temperature range, as long as the indoor temperature can be controlled in this range, the requirements can be satisfied.

4.4 The Standards

The ASHRAE standards use the PMV-PPD model and adaptive model to assess occupants' thermal comfort in the air-conditioning periods and the natural-ventilation periods. While in China, the GB standards about thermal comfort are always similar to the ASHRAE standards. Fig. 10 and Fig. 11 show the compared results we get with the standards in this survey.

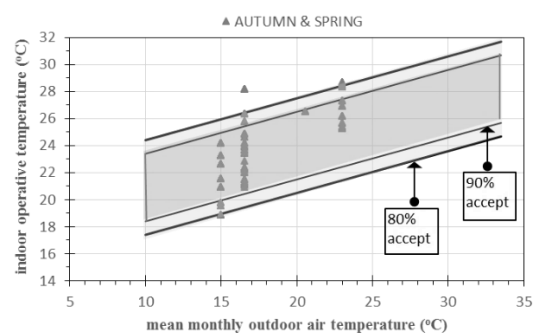
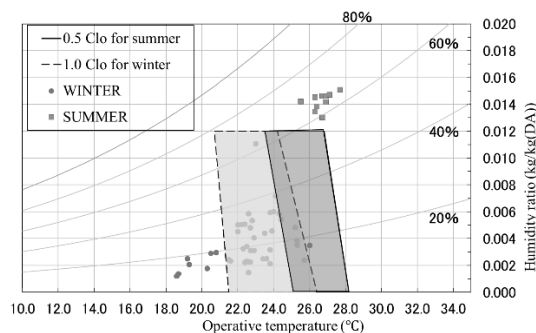

Figure 10. Indoor temperature we get in the survey. Background: ASHRAE 55 standard for air-conditioning

Figure 11. Indoor temperature we get in the survey, as a function of a monthly average of outdoor temperature. Background: ASHRAE 55 standard for natural ventilation

As shown in Fig. 10, in summer, the real environment is more warm and humid than the standard. Yet as discussed before, people won't feel uncomfortable. In winter, temperatures match the standards well in most cases, and all of the points are higher than 18°C (the lower limit for heating in the north of China). As previously discussed, there are some people who feel cold in autumn. In Fig. 11, we can see that no point is lower than the 80% accept range. All these means that the standards do not fit the classrooms well, we need to do more research to find out the rules to the assess occupants' thermal comfort in classroom buildings.

Although we take a comparison between the results and the ASHRAE standards like this. We use the standards for air-conditioning buildings to compare to the results in summer and winter, and the standards for no mechanical cooling system buildings to compare to the results in autumn and winter, in fact it is not meet the requirements of ASHARE standards in the comparison above. ASHARE Standards can only be used in air conditioning or no mechanical cooling system buildings, but in the actual construction in China these does not see more. Most of the buildings are air conditioning in the summer and mixing ventilation in other seasons. Thus we need more standards to apply to such buildings.

5 Conclusions

(1) In the majority of the time in autumn and spring, natural ventilation can meet the requirements of respondents in the classrooms in Beijing.

(2) Thermal sensations are different in different seasons. In this research, the neutral temperature is 26.9°C in summer, while it is 22.9°C in winter. The main reason is the difference between the clothing insulation. Compared with the winter, respondents in autumn don't adapt to the cold, so they are more sensitive to temperature change when the temperature is low.

(3) During the seasons when the natural ventilation can't meet the requirements, individual difference should be considered when we control the air-conditioning system. Even if the indoor temperature is controlled to the neutral temperature, it can't satisfy all respondents' requirements. The proportion of respondents who feel neutral is still keeping the high level if it control to the acceptable temperature range. So considering energy consumption, the acceptable temperature range might be the control aim for the system.

6 Acknowledgement

Supported by Tsinghua-Toshiba Energy & Environment Research Center, and China Postdoctoral Science Foundation (2013M530633).

7 References

ASHRAE, 2012. ASHRAE Handbook, Fundamentals(SI). Atlanta: American Society of Heating,

Refrigerating and Air-Conditioning Engineers.

Cao B., Zhu Y., Ouyang Q., Huang L., 2012. Field study of indoor thermal comfort in campus buildings in Beijing during summer and winter. *Journal of HV&AC*, 05:84-89.

Chen H., Zhang Y., Wang J., Meng Q., 2010. Thermal comfort in naturally ventilated buildings in hot humid area of China in summer: an example study of Guangzhou. *Journal of HV&AC*, 02:96-101.

Li B., Liu J., Yao R., 2007. Investigation and analysis on classroom thermal environment in winter in Chongqing. *Journal of HV&AC*, 05:115-117.

Liu J., 2007. *Study on the Indoor Thermal Environment and Human Thermal Comfort In Natural Ventilation Building in Summer-Hot and Winter-cold Zone*. MSc. Chongqing University.

Luo M., Li B., Xu X., 2005. Research on Classroom Thermal Environment during the summer in Chongqing. *Journal of Chongqing Jianzhu University*, 01:88-91.

Mao Y., 2007. *Study on climate adaptability of human beings to thermal comfort in China*. MSc. Xian University of Architecture and Technology.

Wang J., Wang Z., 2007. Field studies on university classroom's thermal comfort in Harbin. *Low Temperature Architecture Technology*, 06:123-124.

Wang Z., Li A., He Y., Yang W., 2012. Human thermal comfort and thermal adaptability in Harbin. *JOURNAL OF HARBIN INSTITUTE OF TECHNOLOGY*, 44(8): 48-52

Zhang Y., Chen H., Wang J., Meng Q., 2010. Human thermal comfort research in hot humid area of China (2): comparison between research findings. *Journal of HV&AC*, 04:26-30+25.

Adaptive comfort relations and comfort temperature ranges from a field study in undergraduate laboratories

Asit Kumar Mishra and Maddali Ramgopal

Department of Mechanical Engineering, Indian Institute of Technology Kharagpur, India – 721302

Abstract

To ascertain comfort levels and effectiveness of available adaptive opportunities for classrooms in the hot-humid regions of India, a thermal comfort field study was conducted in an undergraduate laboratory class in Kharagpur. The study, carried out between January and April 2013, had participation from 121 students and yielded 338 responses. Analysis of the results showed that comfort temperatures found in the field study had close resemblance to the predicted comfort temperatures evaluated from certain existing standard adaptive comfort equations. This was in spite of the standards having been developed using observations from studies that had occupants with distinctly lower metabolic rates than encountered in the current study. This is ascribed to the level of acclimatization among the subjects as well as the availability of more adaptive avenues/more flexibility, during laboratory classes.

Keywords: adaptive comfort; laboratory classes; natural ventilation; hot-humid climate; adaptive opportunities

1 Introduction

It is well accepted that thermal environment of classrooms has a significant impact on the teaching-learning process (Auliciems, 1972; Mendell and Heath, 2005). For a growing economy like India, where the number of educational institutions, as well as enrolments in them, is rising fast (UGC, 2008), any compromise of learning environments is unacceptable. Historically, Indian classrooms have been naturally ventilated (NV) along with ample use of fans. With India's energy deficit keeping as high as 26% recently (IEA, 2011), a sudden shift to use of air-conditioning in all the classrooms is unlikely and unsustainable.

Results from several recent field studies vouch for the ease with which Indians adapt to their local climate (Deb and Ramachandraiah, 2010; Dhaka et al., 2013; Indraganti, 2010; Indraganti et al., 2013; Pellegrino et al., 2012). From sustainability point of view, adaptive comfort standards would be an ideal choice for ensuring comfort in Indian classrooms. The user guide to Energy Conservation Building Code (ECBC), issued by Bureau of Energy Efficiency, Government of India, also mentions the adaptive comfort model given in ASHRAE Standard 55-2004 as an optional method for determining comfort in NV buildings (BEE, 2009). Current concerns for energy efficiency and sustainability mean that comfort standards of future will need to push the limits to save the proverbial extra penny rather than settle for narrow comfort bands. If the long term acclimatization of inhabitants in tropical climates could broaden the upper limits of comfort standards that would give building designers

some important leeway. At the same time, a review of several field studies on thermal comfort found that researchers working in classrooms often observe classrooms to have lesser number of adaptive opportunities and more constraints in their use (Mishra and Ramgopal, 2013). To the best of our knowledge, the study done by Pellegrino et al. (2012) was the sole existing field study in Indian classrooms. So, to add to the body of research in this important area, a field study was conducted during the regular semester schedule of an undergraduate laboratory class. The objectives of this study were:

- Verify the suitability of using existing adaptive comfort equations for predicting comfort levels in Indian NV classrooms
- Ascertain if students are able to effectively adapt to their surroundings using the available opportunities
- Check if sustained metabolic rates that are slightly higher than the near sedentary levels, given for current adaptive standards, compromise the predictive power of such standards

A portion of the findings from this field study has been reported elsewhere (Mishra and Ramgopal, 2014). The previous work reported regression neutral temperature and temperature zones for thermal comfort using different criteria for assessing acceptability. Results showed that the students adapted to their NV surroundings well and a majority of them were comfortable over the range of 20 to 31 °C. An adaptive comfort equation (ACE) was also given based on survey data and predicted comfort temperatures from this ACE were compared to predictions from certain standard adaptive comfort models. The current work delves further along this line by comparing observed comfort temperatures of the survey population on all 12 survey days with prediction from different adaptive comfort models. Statistical significance of the deviations in predictions from different models is presented. Comfort temperature ranges over a single survey day, as opposed to the entire survey duration, are discussed. A brief analysis of adaptive opportunities available and their adequacy in facing the surroundings is also given.

2 Methodology

The study was conducted from January 2013 to April 2013 in undergraduate laboratories of the Indian Institute of Technology Kharagpur (IIT). Kharagpur has a Tropical savannah type (Aw) climate. The period from January to April comes under Spring semester schedule of the institute. This particular semester was chosen as it has both the warmest (April) and the coolest (January) months during which regular classes take place. This meant that a wide spectrum of adaptive behaviour among the students could be observed and it could be determined if the broad range of temperatures, faced over a relatively short duration of four months, adversely impacts adaptive abilities. Surveys took place on all twelve class days of the laboratory course during the semester. As is usual in the institute, laboratory classes were held during the post noon session. Details of the study location, description of the buildings, subjects, questionnaire and survey methodology employed can be found in the earlier work (Mishra and Ramgopal, 2014). Brief outline of methodology is provided in Table 1.

For the activity level during a typical laboratory class, a met rate of 1.6 was used, as per the recommendations in ISO 7730-2005 (ISO, 2005). All subjects had been

residents of Kharagpur for at least two and a half years and all of them were Indian nationals. Hence, they had a significant level of acclimatization to the local climate.

Table 1. Survey methodology.

Survey questionnaire	<p>Subjects briefly introduced to structure and purpose of the survey before being asked to answer the questionnaire.</p> <p>Questions:</p> <ul style="list-style-type: none"> • Thermal sensation on ASHRAE scale • Thermal comfort on Bedford scale • Thermal preference • Acceptability of thermal environment • Air velocity sensation • Humidity sensation 				
Survey activities	<ul style="list-style-type: none"> • Survey started 75 to 90 minutes after beginning of class • Time taken to complete survey activities: 35 – 40 minutes • Measurements of dry and wet bulb temperature and air velocity taken at shoulder height at five places around student groups (~10 in number) as they filled up questionnaire • One measurement of globe temperature per student group • No major variations in thermal conditions around different student groups. Hence, further analysis done with averaged out values of environmental parameters • Outdoor temperature data taken from the in-campus meteorological station run by the Department of Physics and Meteorology • Clo value estimated by matching student ensembles with a set of standard ensembles 				
Instruments	Instrument	Make	Range	Resolution	Remarks
	Sling psychrometer	Local	0 to 120 °F	1 °F	Mercury thermometers
	Globe thermometer	constructed	-10 to 110 °C	1 °C	Alcohol thermometer, plastic globe of 70 mm diameter
	Anemometer	Lutron AM4201	0.1 to 30 m/s	0.1 m/s	Vane-type

2.1 A summary of observations

A short summary of certain important outdoor and indoor parameters recorded during the survey days is given in Table 2. Minimum and maximum values for the mean thermal sensation vote (MTSV) on the seven point ASHRAE scale are also given in this table. Daily mean temperatures were calculated as an arithmetic mean of daily maximum and minimum temperature. The running mean temperature (RMT) given in the table is a seven day running mean which was evaluated in a method similar to that used in EN15251 (Nicol and Humphreys, 2010). Total number of students taking the survey on any day varied between 23 and 32.

In Table 2, t_{op} represents the operative temperature; p_v represents the partial pressure of water vapour in air; v_a represents the average air velocity; and APD represents the actual percentage dissatisfied, i.e., voting "Not Acceptable" on the survey questionnaire to the question regarding acceptability of indoor thermal conditions.

Table 2. Summary of observations.

Parameter	Maximum	Minimum
Outdoors		
Daily minimum	25 °C	9 °C
Daily maximum	42 °C	20 °C
RMT	32.8 °C	16.9 °C
Daily mean	33 °C	14.5 °C
Indoors		
t_{op}	35 °C	22 °C
p_v	3.04 kPa	1.06 kPa
v_a	0.6 m/s	0.05 m/s
Average clo	0.91 clo	0.44 clo
MTSV	1.74	-0.73
APD	59%	0%

3 Results and Analysis

Over the twelve days of survey, 342 responses were obtained from a group of 121 students. Of these responses, four had to be classified as 'invalid'. Such a classification was done when the subject answered 'no change' to the question on thermal preference and yet found the environment 'not acceptable' or when the subject voted for an extreme on the ASHRAE thermal sensation scale and preferred even more of the same sensation on the thermal preference scale. For further analysis, only the 338 responses that were not invalidated were used. The package R (R Core Team, 2012) was used in all the statistical analysis performed.

Comfort temperature on any particular survey day was calculated by using the MTSV and operative temperature recorded on that day, as inputs for the Griffiths' formula. A value of 0.5/°C was used for the slope in Griffiths' formula, following the recommendations of Humphreys et al.(2013). Since globe and operative temperatures were almost equal during all the survey days, Griffiths' formula was evaluated using operative temperature rather than globe temperature. This allowed the relationship between indoor comfort and outdoors to be expressed in terms of operative temperature.

3.1 Comparison of comfort temperatures with existing models

One of the goals at the start had been to check how well existing adaptive comfort models would be able to predict the comfort temperatures obtained from the field study. Certain differences between model predictions and study results were expected on two counts. One was the higher metabolic rate of the subjects; the other was long term acclimatisation of the subjects to a hot-humid climate. As standard adaptive models, the ACE given in EN15251 (Nicol and Humphreys, 2010) and ASHRAE Standard 55 (ANSI/ASHRAE, 2010) are taken. As the slope suggested by Humphreys et al. (2013) in Griffiths' equation was used, the results are checked against predictions of the equation put forth in the same work as well. The model proposed by Nguyen et al. (2012) for hot-humid climates of South East Asia is also taken for comparison considering the geographical proximity of India with South East Asia and certain shared cultural traits. A more recent model proposed by Toe and Kubota (2013) for hot humid climates, which they have derived using a meta-analysis of the ASHRAE RP-884 database, is another model considered in the comparisons.

Both ASHRAE Standard 55-2010 and EN15251 recommend adjustments to the comfort temperature in presence of enhanced air velocity. So, these adjusted values are also taken as two sets of predictions when comparing the field study data. With all the fans being off during January and February, air velocities remained close to 0 and thus comfort temperatures during these months were not adjusted. On the other days, comfort temperatures from EN15251 prediction were adjusted using the day's recorded average air velocity as an input to the formula: $7 - \frac{50}{4 + 10\sqrt{v_a}}$ (Nicol and Humphreys, 2010). Since the average air velocity never exceeded 0.6 m/s, as a correction, 1.2 °C was added to the ASHRAE Standard 55 predictions (ANSI/ASHRAE, 2010). An overview of the different modes used for comparison is given in Table 3.

Table 3. Overview of adaptive comfort models.

	Comfort equation	Outdoors metric	Survey population	Correction for enhanced air velocity
ASHRAE Standard 55	$t_c = 0.31 t_{out} + 17.38;$ $R^2 = 0.70$	PMOAT	Worldwide	1.2 °C (for 0.3 m/s < v_a < 0.6 m/s)
EN15251	$t_c = 0.33 t_{out} + 18.8;$ $R^2 = 0.358$	RMT	European	$7 - \frac{50}{4 + 10\sqrt{v_a}}$ (for $v_a > 0.1$ m/s)
Nguyen et al.	$t_c = 0.341 t_{out} + 18.83;$ $R^2 = 0.52$	Monthly mean temperature	Hot, humid regions of South-East Asia	n.a.
Humphreys et al.	$t_c = 0.53 t_{out} + 13.8;$ $r = 0.89$	RMT (preferred)	Worldwide	n.a.
Toe and Kubota	$t_c = 0.57 t_{out} + 13.8;$ $R^2 = 0.64$	MOAT	Hot, humid regions from RP 884 database	n.a.

For the comparisons, Δt_c is defined as $\Delta t_c = t_c - t_{c,p}$, where t_c is the comfort temperature from the field study and $t_{c,p}$ is the predicted comfort temperature from different models. Values of Δt_c on the twelve survey days for the aforementioned different models are plotted in Figure 1. From Figure 1 it can be observed that both the ASHRAE model and ASHRAE adjusted model consistently under predict comfort temperatures of this field study. However, for both EN15251 and Standard 55 models, adjustments due to enhanced wind velocity bring the predictions closer to the measured values. It is also observed that the closest predictions come from Nguyen et al.'s model, Toe and Kubota model, and the EN15251 enhanced air velocity adjusted model.

Paired Wilcoxon signed rank test is used to check if differences found between predicted and observed values are significant. A first observation is that the prediction set from the adjusted models for ASHRAE and EN15251 are significantly different from the original model's prediction set (p value of 0.01 and 0.02 respectively). Among all the models considered, the models whose predictions are not significantly different from the observed values, at a 5% significance level, are the adjusted

EN15251 model, Toe and Kubota model, and Nguyen et al.'s model (p values of 0.30, 0.31, and 0.22 respectively).

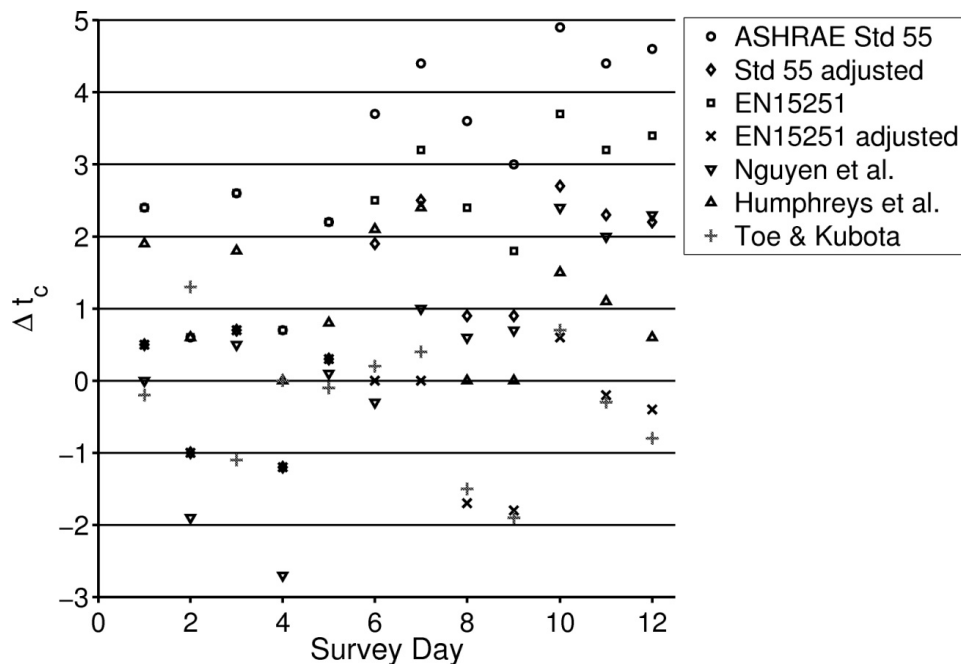

Figure 1. Differences in comfort temperature found between study results and predictions of existing models

This exercise yielded a few notable results. One was that use of adjustments for enhanced air velocities is very useful for accurate comfort temperature prediction especially when considering locations like India where fans are ubiquitous in NV buildings. Secondly, the overall good performance of Toe and Kubota and Nguyen et al.'s model showed that a model developed for similar climatic and cultural conditions would be better at predicting comfort temperatures of occupants. But most importantly, what is found is that in spite of a higher metabolic rate (more than 20% higher than that of seated office occupants), the neutral temperatures found in this study are not starkly different from the predictions of some of the existing ACEs. With increased activity, one might have expected a drop in the comfort temperatures. But the maximum difference found on any day is with the ASHRAE Standard 55 model where the model under predicts comfort temperature by 5 °C. This could be due to the level of acclimatization of the occupants along with other contributing factors. This is further discussed in Section 3.4.

3.2 Formulating an adaptive comfort relation with outdoors

As remarked upon in the previous section, different existing ACEs tend to use different indices for the outdoors. So, before trying to relate indoor comfort conditions with outdoors, a check was done to see if the different outdoor indices that might be used as input to the model are significantly different from each other. Once more paired Wilcoxon signed rank test is used and it is found that at a significance level of 5%, values for PMOAT, MOAT, RMT, and current month's mean temperature are not significantly different. Also, values of PMOAT calculated using 9, 11, and 13 day averages – instead of seven days – are not significantly different from the seven day PMOAT.

Regression equations are developed between the indoor comfort temperature and the following outdoor temperature indices: RMT, PMOAT-7 day, PMOAT-9 day, PMOAT-11 day, PMOAT-13 day, MOAT, and the current month's mean temperature. All these regression relations were found to be significant at 0.1% level. The R^2 values of these relations are given in Figure 2. R^2 values for the relations using RMT, PMOAT-7 day, and MOAT are not very different though the value is highest when using MOAT – similar to what Toe and Kubota (2013) found in their analysis. On the other side though, use of more number of days in calculating PMOAT reduces strength of relation quite rapidly. As any relation involving MOAT would require knowledge of the current day's temperature, such a relation would have limited utility as a dynamic/real-time prediction tool. In Equation 1, the regression relation between PMOAT-7 day (t_{PMOAT}) and t_c is given, and in Equation 2, the regression relation between MOAT (t_{MOAT}) and t_c is given.

$$t_c = 0.53t_{PMOAT} + 15.23; R^2 = 0.924, p < 0.001 \quad (1)$$

$$t_c = 0.49t_{MOAT} + 15.45; R^2 = 0.928, p < 0.001 \quad (2)$$

As already observed though, use of Toe and Kubota's model, or Nguyen et al.'s model, or the EN15251, with adjustment for higher air velocity, gives results that are statistically indistinct from the results that the above equations would provide. Thus, Equations 1 or 2 are not proposed as yet another ACE in the already existing multitude of ACEs. These equations are provided here to be informative rather than normative.

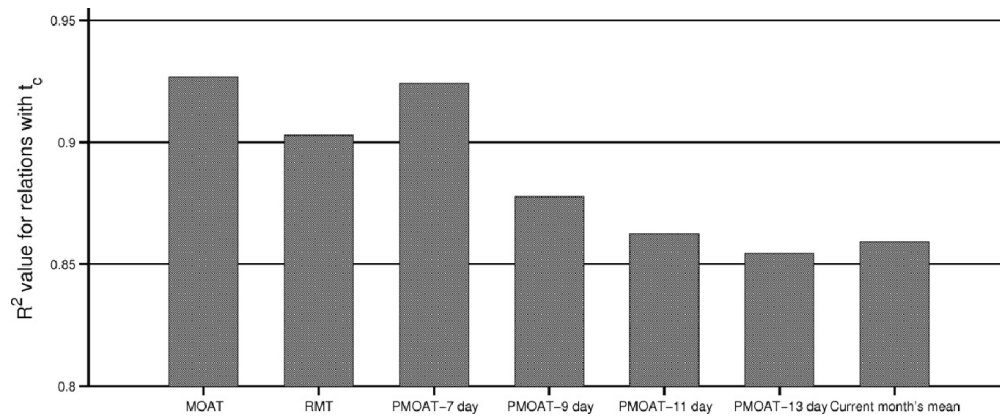

Figure 2. R^2 values of correlations using different indices of outdoor temperature

3.3 Temperature ranges for ensuring comfort

The results had shown that over the entire survey duration, 80% occupants were comfortable over a temperature range of 20 to 31 °C (Mishra and Ramgopal, 2014). This however represents the effects of an entire range of adaptive abilities occupants employed as the season changed from winter to summer. For example, over the survey duration, minimal clothing value observed was 0.39 clo while maximal was 0.99 clo. Over a single day or in particular during the three hour duration of the class, full spectrum of adaptive opportunities can rarely be brought into play. It was required to see what range of change in operative temperature during class timings on a day would still leave 80% of occupants comfortable. To this end, the method used by Nicol and Humphreys (2007) of correlating the deviation between t_c and t_{op} during survey period ($\Delta t_n = t_c - t_{op}$) with the percentage of occupants who found their thermal

environment to be acceptable (PS) on that day is utilised. Equation 3 gives a second order polynomial fit between Δt_n and PS.

$$PS = -3.6\Delta t_n^2 + 3.22\Delta t_n + 96.38; \quad R^2 = 0.91, \quad p < 0.001 \quad (3)$$

Coefficient of the first power of Δt_n in Equation 3 failed to achieve significance at 5% level ($p=0.15$). So, ignoring contribution of the first-order term, Equation 3 is rewritten as:

$$PS = -3.6\Delta t_n^2 + 96.38; \quad R^2 = 0.91, \quad p < 0.001 \quad (4)$$

Equation 4 thus shows that around 4% people would be dissatisfied even if there is a perfect match between t_c and t_{op} . It also shows that corresponding to an 80% value for PS, Δt_n value needs to be $\approx \pm 2$ °C. This value is quite similar to the value obtained by Nicol and Humphreys (2007) from their analysis of the SCATS database. However, this finding comes with a qualifier. The current studies were all limited to post noon periods. So, the temperature ranges experienced by the occupants were not typical of the whole day's but rather of the hottest part of the day. Thus, the swing of 2 °C that is found to be okay with 80% of the subjects may not be extrapolated to express the temperature swings allowable over an entire day. Rather, such a range is representative of the comfort ranges for the warmer half of a day. The comfort temperatures found during the survey days along with the ACE line for PMOAT and allowed temperature drifts are presented in Figure 3.

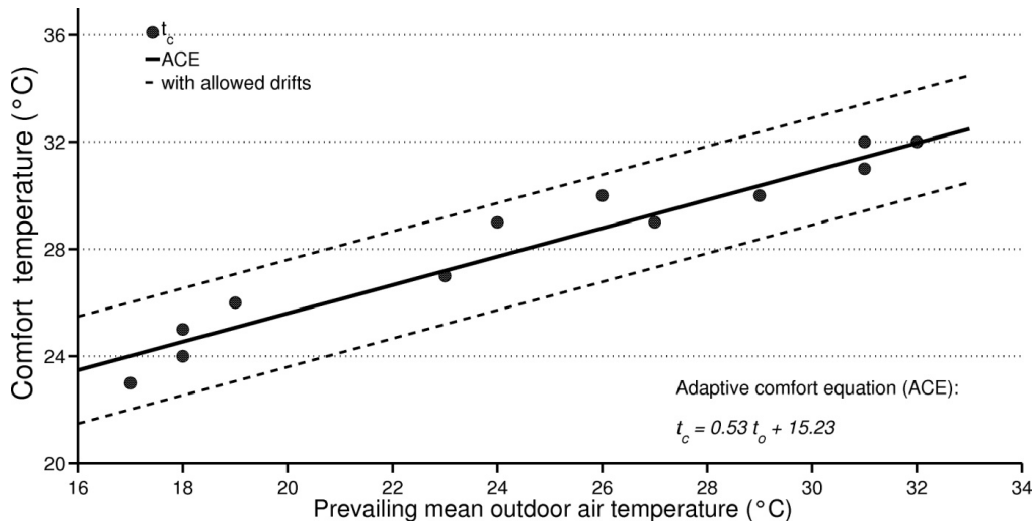

Figure 3. Comfort temperatures and adaptive comfort equation

3.4 Adequacy of adaptive opportunities in laboratories

Activity levels and patterns for laboratory and lecture classes are markedly different. Apart from the higher activity level, laboratory classes are also longer. For example, in IIT, while average lecture classes are of one hour, average laboratory classes are three hours long. On the positive side though, students have a lot less restriction on their adaptive behaviours. They do not have to occupy specific seats and maintain a consistent posture. They are free to move about and break the monotony. During summer months, students were observed to take multiple breaks for drinking water (drinking water being provided within the lab premises). They clustered around or

under fans while not actively engaged with their respective experimental set ups. Changes made to clothing were frequent. During winter, depending on the conditions, students take off or zip up their jackets, sweat-shirts. In summer, they tend to loosen the first couple of buttons on the shirt/t-shirt or fold up the sleeves of full sleeve shirts.

As discussed in Section 3.1, the higher metabolic rate did not cause a lowering of comfort temperatures as given from certain accepted adaptive comfort models. The availability of more adaptive opportunities in settings of the current study, compared to those available in lecture classes or offices, is believed to be the reason behind this. As discussed by Baker and Standeven (1996), availability of adaptive opportunities can ameliorate the stress produced by a thermal stimulus. While this thermal stimulus could be in terms of temperature, it could also be in terms of metabolic activity. Thus, an enhancement in available adaptive opportunities is found to be able to successfully deal with slightly increased met rates and currently existing adaptive comfort models are able to predict comfort conditions without being grossly erroneous. It is however likely that at a certain point increased metabolic rate will be high enough that enhanced adaptive opportunities will not be effective. Finding where this tipping point occurs would require further studies.

4 Conclusion

Results from the current field study validated the use of EN15251 model, with adjustment for higher air velocity, Toe and Kubota's model, and Nguyen et al.'s model for predicting comfort conditions in NV classrooms of the hot-humid regions of India. This emphasizes on the use of adjustments for air velocity when using an ACE for locations where use of fans is widespread as well as highlights the fact that an ACE developed from data collected in similar climatic conditions can often be more useful than a global model.

In agreement with ASHRAE Standards 55 recommendations, PMOAT calculated over seven days was found to be a suitable index for outdoor conditions. And in what can be termed as a further validation of the principles of adaptive comfort, greater adaptive opportunities were observed to successfully counteract slightly higher metabolic rates without any appreciable changes in comfort zones.

Acknowledgements

The cooperation extended to us by our subjects is acknowledged. We also deeply appreciate the help and support from laboratory staff members: Mr. R. Dey and Mr. P. Roychowdhury. For giving us access to historical and current temperature data, we are thankful to Prof. B. K. Mathur of the Department of Physics and Meteorology. Our thanks also go to Prof. P. K. J. Mohapatra, Department of Industrial Engineering, for the insights provided by him on statistical methods and analysis.

Abbreviations

ACE	adaptive comfort equation
APD	actual percentage dissatisfied
MOAT	mean outdoor air temperature (daily mean)
MTSV	mean thermal sensation vote
NV	naturally ventilated
PMOAT	prevailing mean outdoor air temperature
RMT	running mean temperature

References

- ANSI/ASHRAE, 2010. Standard 55-2010. Thermal comfort conditions for human occupancy. ASHRAE, Atlanta.
- Auliciems, A., 1972. Classroom performance as a function of thermal comfort. *International Journal of Biometeorology*, 16(3), pp 233-246.
- Baker, N. and Standeven, M. , 1996. Thermal comfort for free-running buildings. *Energy and Buildings*, 23(3), pp 175-182.
- BEE. 2009. Energy Conservation Building Code user guide. Bureau of Energy Efficiency. New Delhi, India.
- Deb, C. and Ramachandraiah, A., 2010. Evaluation of thermal comfort in a rail terminal location in India. *Building and Environment*, 45(11), pp 2571-2580.
- Dhaka, S., Mathur, J. , Wagnerb, A. , Agrawal, G. D. and Garg V., 2013. Evaluation of thermal environmental conditions and thermal perception at naturally ventilated hostels of undergraduate students in composite climate. *Building and Environment*, 66, pp 42-53.
- Humphreys, M. A., Rijal, H. B., and Nicol, J. F., 2013. Updating the adaptive relation between climate and comfort indoors; new insights and an extended database. *Building and Environment*, 63, pp. 40-55.
- IEA, 2011. Energy balances of non-OECD countries. International Energy Agency. Paris, France.
- Indraganti, M., 2010. Using the adaptive model of thermal comfort for obtaining indoor neutral temperature: Findings from a field study in Hyderabad, India. *Building and Environment*, 45(3), pp 519-536.
- Indraganti, M., Ooka, R., and Rijal, H. B., 2013. Field investigation of comfort temperature in Indian office buildings: A case of Chennai and Hyderabad. *Building and Environment*, 65, pp 195-214.
- ISO, 2005. ISO 7730: Ergonomics of the thermal environment Analytical determination and interpretation of thermal comfort using calculation of the PMV and PPD indices and local thermal comfort criteria. 3rd edn., Geneva.
- Mendell, M. J. and Heath, G. A., 2005. Do indoor pollutants and thermal conditions in schools influence student performance? A critical review of the literature. *Indoor Air*, 15(1), pp 27-52.
- Mishra, A. K. and Ramgopal, M., 2013. Field studies on human thermal comfort – An overview. *Building and Environment*, 64, pp 94-106.
- Mishra, A. K. and Ramgopal, M., 2014. Thermal comfort in undergraduate laboratories – A field study in Kharagpur, India. *Building and Environment*, 71, pp 223-232.
- Nguyen, A. T., Singh, M. K., and Reiter, S., 2012. An adaptive thermal comfort model for hot humid South-East Asia. *Building and Environment*, 56, pp 291-300.
- Nicol, F. and Humphreys, M., 2007. Maximum temperatures in European office buildings to avoid heat discomfort. *Solar Energy*, 81(3), pp 295-304.

Nicol, F. and Humphreys, M., 2010. Derivation of the adaptive equations for thermal comfort in free running buildings in European Standard EN15251. *Building and Environment*, 45(1), pp 11-17.

Pellegrino, M., Simonetti, M., and Fournier, L., 2012. A field survey in Calcutta. Architectural issues, thermal comfort and adaptive mechanisms in hot humid climates. *Proceedings of 7th Windsor Conference: The changing context of comfort in an unpredictable world*, NCEUB, Windsor, UK.

R Core Team, 2012, R: A Language and Environment for Statistical Computing. R Foundation for Statistical Computing, Vienna, Austria. URL: <http://www.R-project.org>

Toe, D. H. C. and Kubota, T., 2013. Development of an adaptive thermal comfort equation for naturally ventilated buildings in hot-humid climates using ASHRAE RP-884 database, *Frontiers of Architectural Research*, 2(3), pp 278-291.

UGC (2008), Higher education in India – Issues related to Expansion, Inclusiveness, Quality and Finance. Secretary, University Grants Commission, New Delhi.

Proceedings of 8th Windsor Conference: *Counting the Cost of Comfort in a changing world*
Cumberland Lodge, Windsor, UK, 10-13 April 2014. London: Network for Comfort and
Energy Use in Buildings, <http://nceub.org.uk>.

Case Study - Thermal Comfort Evaluations in Prayer Halls in two continents.

Ashak Nathwani¹,

¹ The University of Sydney, Faculty of Architecture, Design and Planning – Australia

Abstract

Field studies have been carried out in selected Prayer Halls to address the research questions namely the impact of air conditioning on comfort of women versus men as well as on general members versus older members of a congregation, who follow universally adopted standard proceedings, and hold prayer meetings every morning from 3.30 am to 5.30 am and every evening from around 7 pm to 9 pm. Comfort evaluations were carried out in three cities - two of which are presented here. The two air conditioned centres involved are: Lisbon, Portugal and Vancouver, Canada, where temperature and humidity were recorded in August 2013.

The outcomes, in each case, have provided valuable data that clearly demonstrates the impact of gender, age and clothing variations on Predicted Mean Vote (PMV) and Predicted Percentage Dissatisfied (PPD). The results have explained some of the key root causes of the complaints that have led to enhancements / upgrades of the respective air conditioning systems.

Keywords: PMV, PPD, thermal comfort, field studies, Prayer Hall.

INTRODUCTION

Gender differences have been generally considered to be small and insignificant but review carried out ([Karjalainen, S. 2011](#)) shows that a growing number of studies have found significant differences in thermal comfort between the genders. Clearly more than half of the laboratory and field studies have found that females express more dissatisfaction than males in the same thermal environments ([Karjalainen, S. 2011](#)).

Statistical analyses have also indicated that female occupants' satisfaction levels were consistently lower than male occupants for all fifteen IEQ factors (including thermal comfort, air quality, lighting, acoustics, office layout & furnishings, and cleanliness & maintenance) addressed in POE questionnaire, and the differences were statistically significant. Logistic regression analysis identified a significant association between female gender and dissatisfaction with individual IEQ factors (Kim et al 2013)

The above research outcomes relate mainly to Office environments. Buildings with intermittent occupancy, such buildings are Churches, Synagogues, Temples and Mosques, require different considerations with regards to thermal comfort compared to commercial and residential facilities.

As can be appreciated there are significant diversities associated with practice of all faiths. There is also a high variety in physical structures and in many instances age differences linked with religious buildings. Thermal comfort requirements need careful envelope design coupled with the appropriate air conditioning system operation strategies. (Al Homoud 2009).

Jamatkhana, the prayer hall used by Ismailis, provide a unique opportunity to carry out detailed comfort analysis related to gender and age, as men occupy the right hand side and the women occupy the left hand side of the hall and the elderly, generally, at the rear of the Hall. In most countries, congregational prayers, involving men and women, are held every morning, from 3.30 to 5.30 am and in the evenings from around 7 pm for approximately two hours. This is in contrast to other studies carried out on this subject, where prayers meetings, mainly involving men are held at five times during the day – with peak attendances often at mid-day – (Kotbi et al 2010). In that study the “clo” value was the summer traditional costume in the Middle East, being 1.05 without headdress and 1.13 with headdress (Al-Ajmi, 2006; ISO9920, 2007). The met value, in that case, was estimated to be 1.3. A paper “Validating Fanger's PMV model in a “real” field study” was presented by Kotbi at the Comfort Conference 2012.

Size of the congregation varies from a handful in the early mornings to a sizeable group on Friday evenings, with peak attendances generally occurring once a month, following a lunar cycle plus on special occasions – approximately around five days annually.

The participants cover the full spectrum of ages from the newly born to the elderly (over 605years). The elderly are more regular in their attendance and most of them sit on chairs at the rear of the Hall. The rest of the congregation (the majority) sits on the carpet. The clothing, for men, is generally long trousers and jackets (with suit and tie worn on special occasions) - “clo” value of 1.2 and dresses or smart casual or saris or Indian style trouser suits for women – “clo” value of 0.95. This would increase to 1.05 if they used shawls – which many carry with them. For the elderly sitting on chairs the respective “clo” value is increased by 0.05 to take into account the chair insulation. The prayer activity, lasting for up to 1 hour – particularly on festive days, is mostly sitting and listening to sermons or having group recitations There are brief periods requiring all to stand up for prayers lasting less than 10 minutes- hence “met” value is taken as 1.2 as compared to 1.3 (Kotbi et al 2010). Same “met” value applies to men and women – however for the elderly the “met” value is reduced to 1.15. Generally social gathering follows the prayers, which may last for another hour.

Most Ismaili prayer halls, particularly in the Western World, are mechanically air-conditioned to achieve a level of thermal comfort for worshippers, bearing in mind that a majority of these buildings are sealed enclosures with no open able windows.

To evaluate the thermal comfort impact on gender and age and at the same time address complaints related to comfort, field studies were carried out in three cities. Two are covered.

The two air conditioned centres involved are:

- Lisbon, Portugal

- Vancouver, Canada

Details of the process adopted for each centre and the outcomes are outlined below.

LISBON CENTRE

Lisbon, Portugal – purpose built in 2002 with 35M by 25M prayer hall, where temperature and humidity recordings were taken in August 2013;



Figure 1. - Inside of the Prayer hall in Lisbon

The analysis was carried out in August - the warmest month. The process involved placing of temperature and humidity loggers (IButtons) in the Prayer Hall over a period of a week, which included days with peak attendances. It is to be noted that the peak attendances were during the evenings when the solar heat gains were low.



Figure 2 - Temporary Air Conditioning Units

Background information:

- › Original under floor “air conditioning” system has not been adequate and appropriate
- › Over the last decade there has been dissatisfaction expressed regarding internal conditions – which led to use of temporary AC units

- › Weather patterns are changing due to global warming – hence there is a need for a more permanent solution with regards to air conditioning, which will be acceptable aesthetically.
- › A better indoor environment is necessary taking into account the aging population, which is more regular in prayer meetings

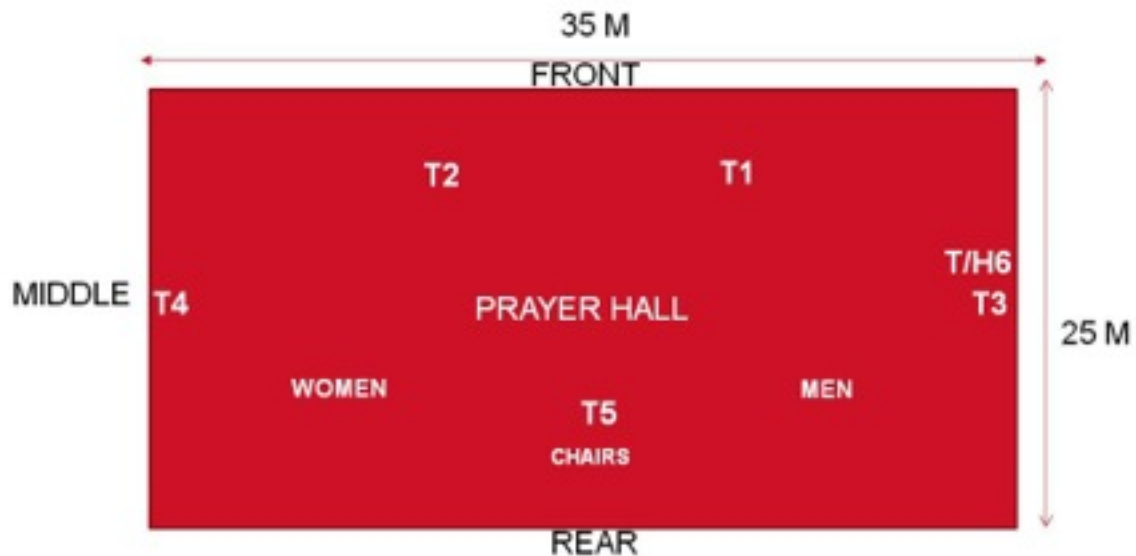

Figure 3. Plan of the Prayer Hall - Lisbon showing locations of I-Buttons - Temperature & humidity

Parameters

- › Air Temperature – Degrees C – as per I-Buttons
- › Humidity – %RH – as per I-Buttons.
- › Air Flow — based on four free standing Air Conditioning Units in operation. Rear 0.4 m/s, middle - 0.21 m/s. at the front -0.1 m/s- as measured
- › Activity – Meditation / Prayers - Met = 1.2 – elderly = 1.15
- › Clothing – Men wearing coats / suits – Clo = 1.2 – elderly on chairs = 1.25
Women wearing dresses, saris, etc – Clo = 0.95 - elderly on chairs = 1.0
- › Radiant Temperature — based on sunlight entering certain parts of the Hall.



Figure 4. I-Button - recorded temperature & humidity every 15 minutes.

Radiant Temperature Estimation.

Impact generally at the rear section due to the amount of glass. All other walls are concrete with stone work. Note – meetings are held at sunset and hence the impact diminishes as the evening progresses.



Figure 5 - Radiant Temperature estimation process.

EVALUATIONS

Data was gathered over several sessions including the monthly special (festival) night, when there were more people.

Graphs with Air Temperature, PMV and PPD have been compiled for all the sittings. However to highlight the research questions, only selected graphs are presented in the following pages: It is to be noted that there is a separate smaller hall, where the early morning prayers are held. No analysis has been carried out for this.

The attendance numbers have been provided by Volunteers who assist with the shoes, which are removed by all worshippers, prior to entering the Prayer Hall. Separate numbers are provided for men and women.

FESTIVAL EVENING – Wednesday 7th August 2013

ATTENDANCE 640 OVERALL – 305 MEN AND 335 WOMEN

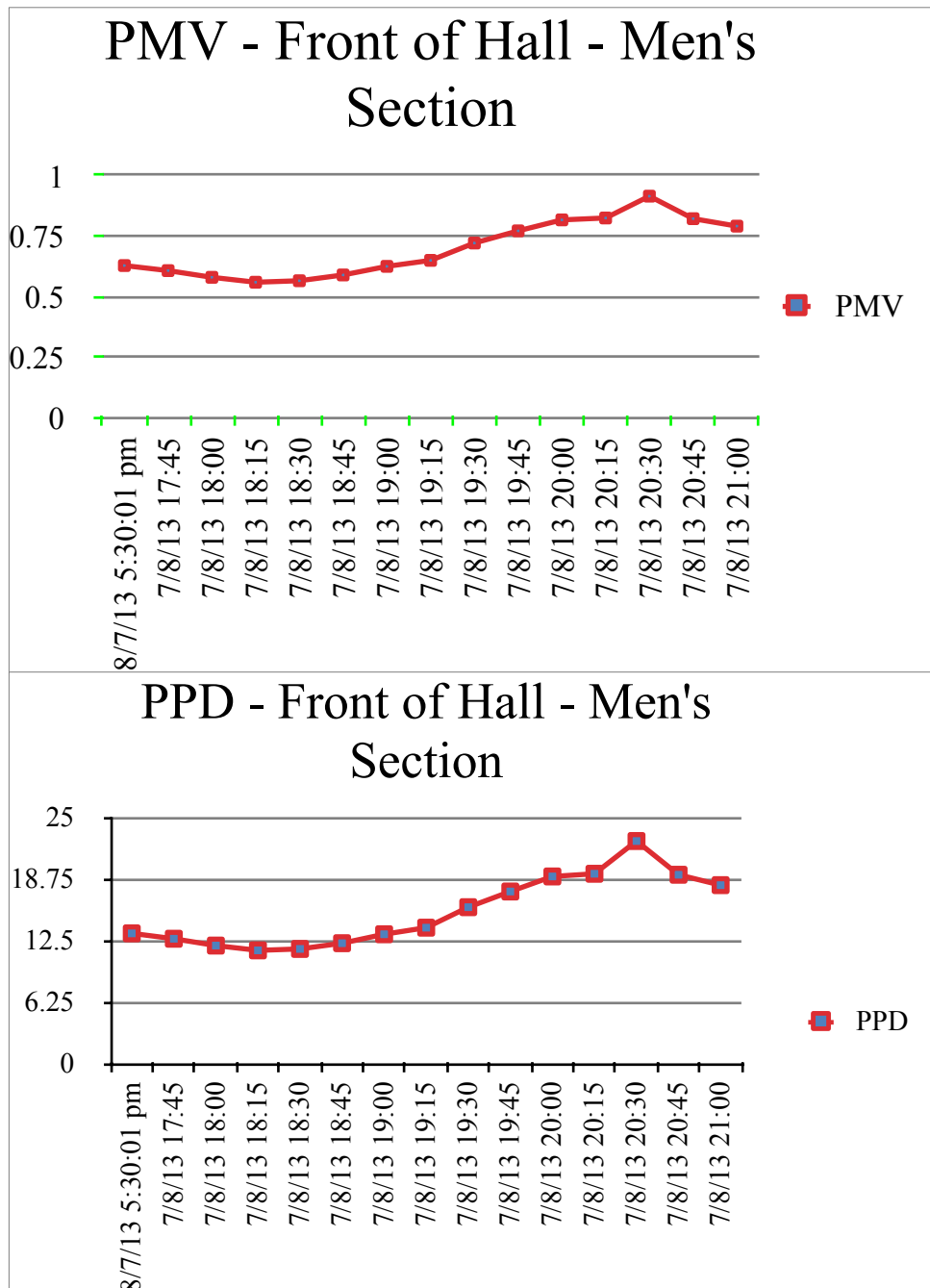

Fig 6 PMV & PPD - Men with Met = 1.2, Clo = 1.2, Air Vel = 0.1 m/s average (measured)

FRONT OF THE HALL (As Per Figure 3)

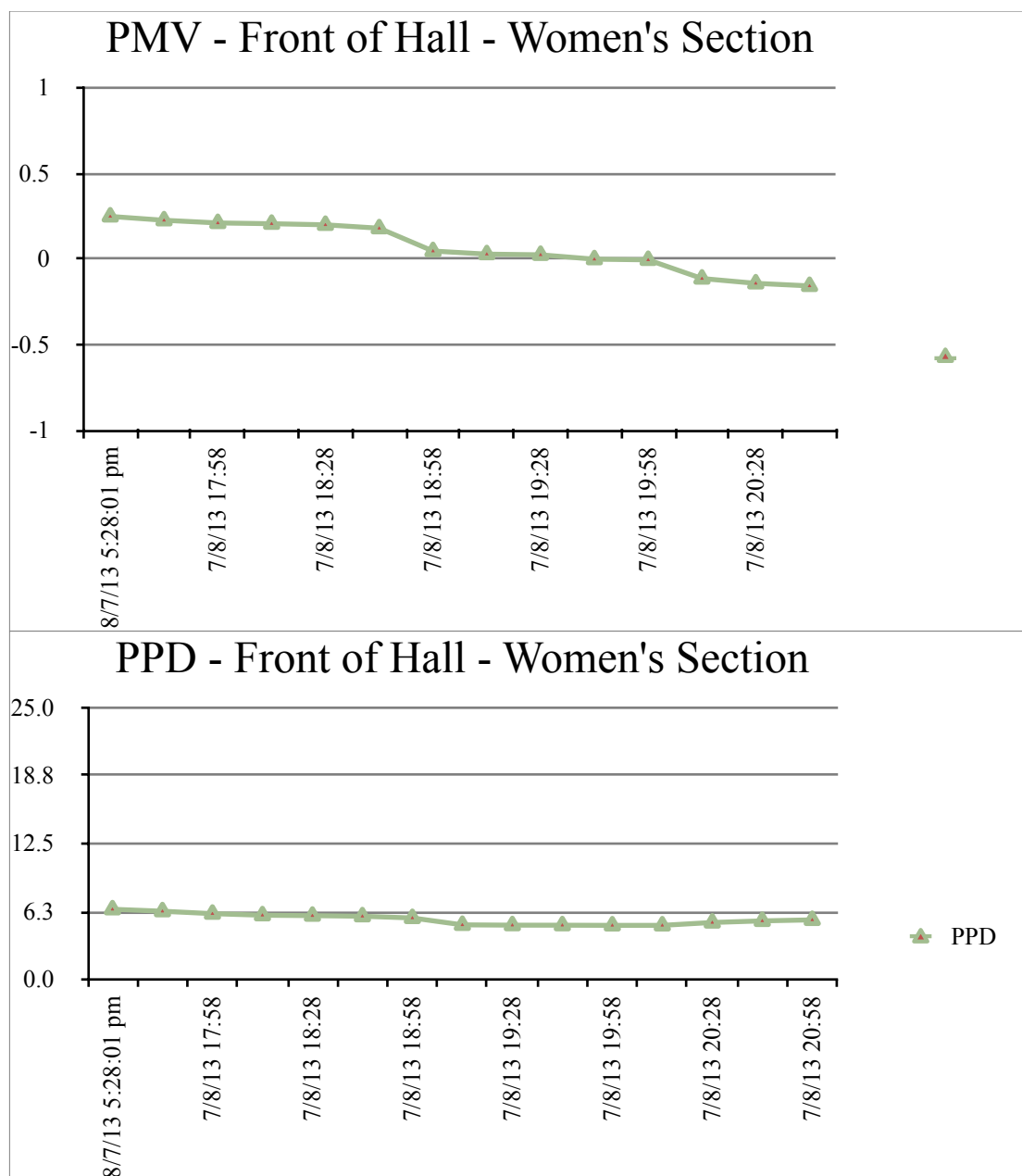

Fig 7 PMV & PPD - Women with Met = 1.2, Clo = 0.95, Air Vel = 0.1 m/s average (measured)

MIDDLE OF HALL (as per Figure 3)

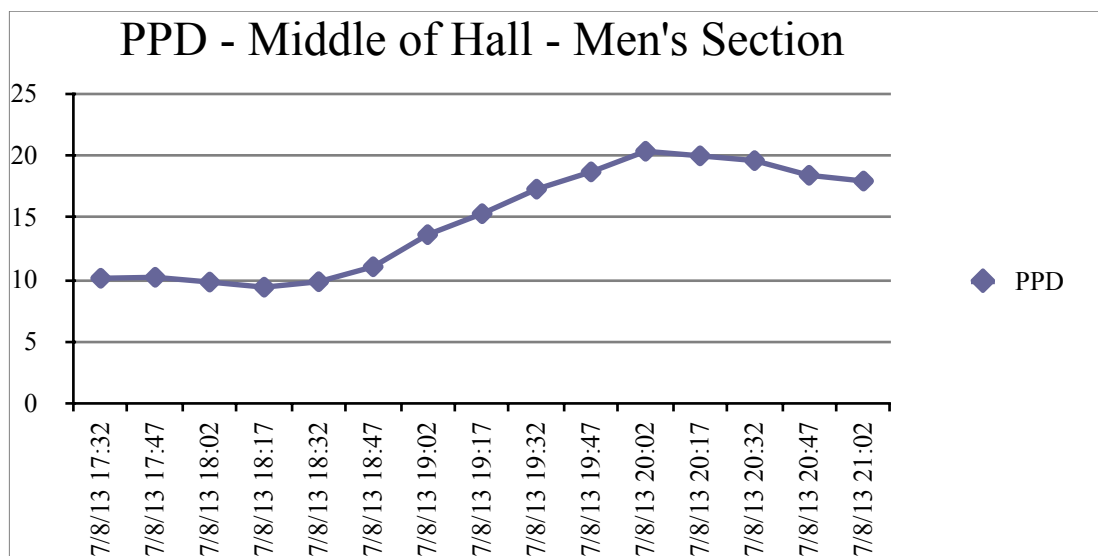
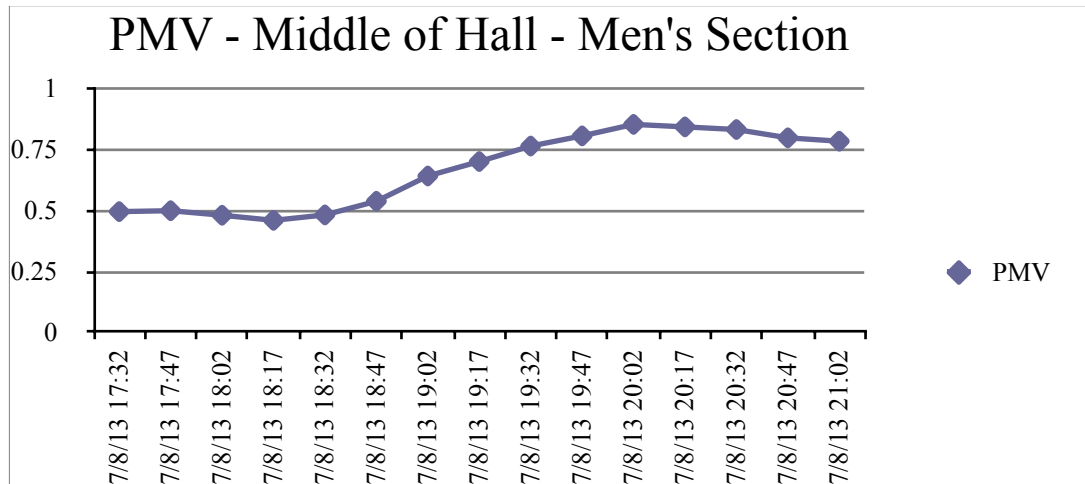

Fig 8 PMV & PPD - Men with Met = 1.2, Clo = 1.2, Air Vel = 0.21 m/s average (measured)

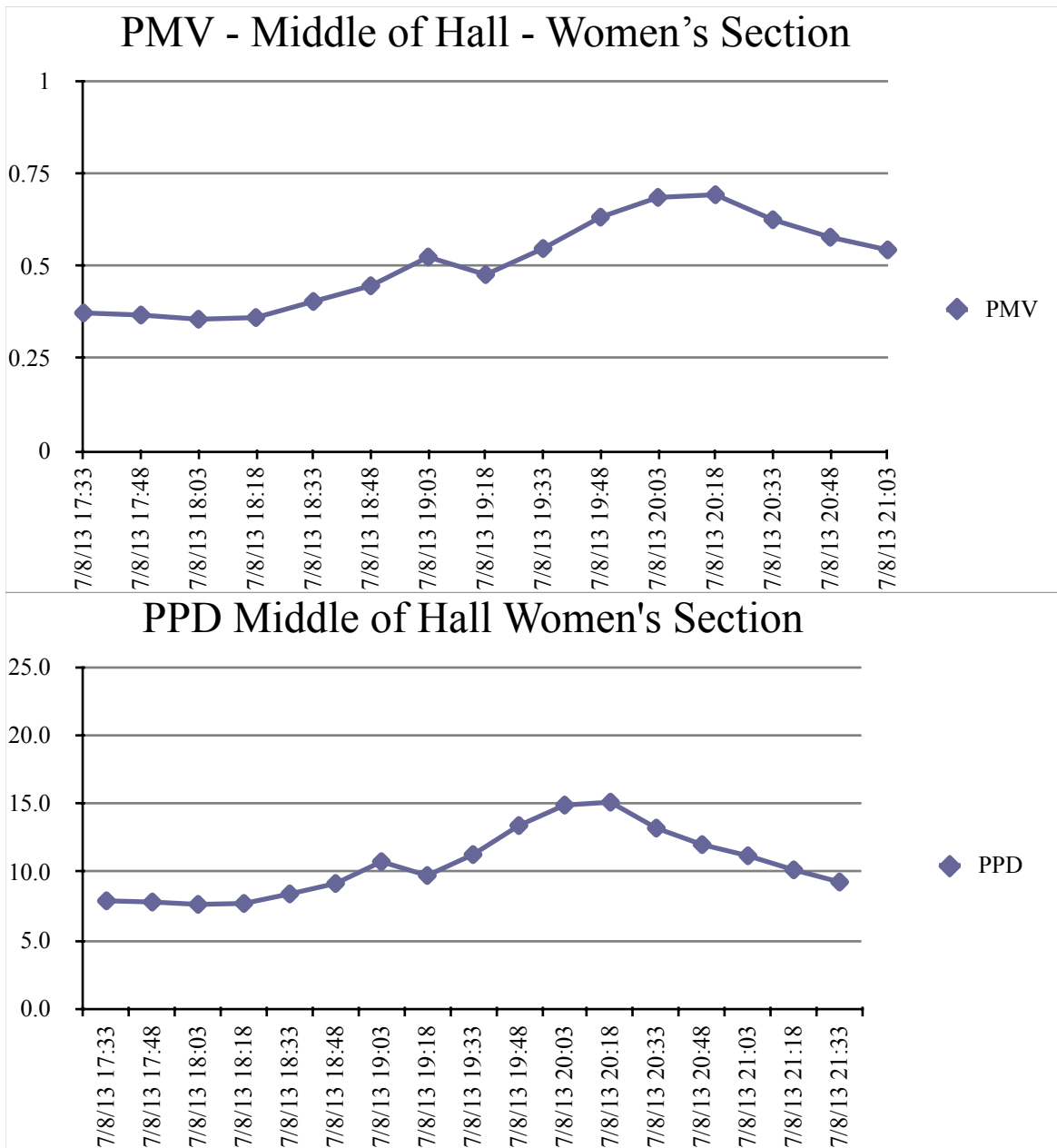

Fig 9 PMV & PPD - Women with Met = 1.2, Clo = 0.95, Air Vel = 0.21 m/s average (measured)

REAR OF THE HALL (as per Figure 3)

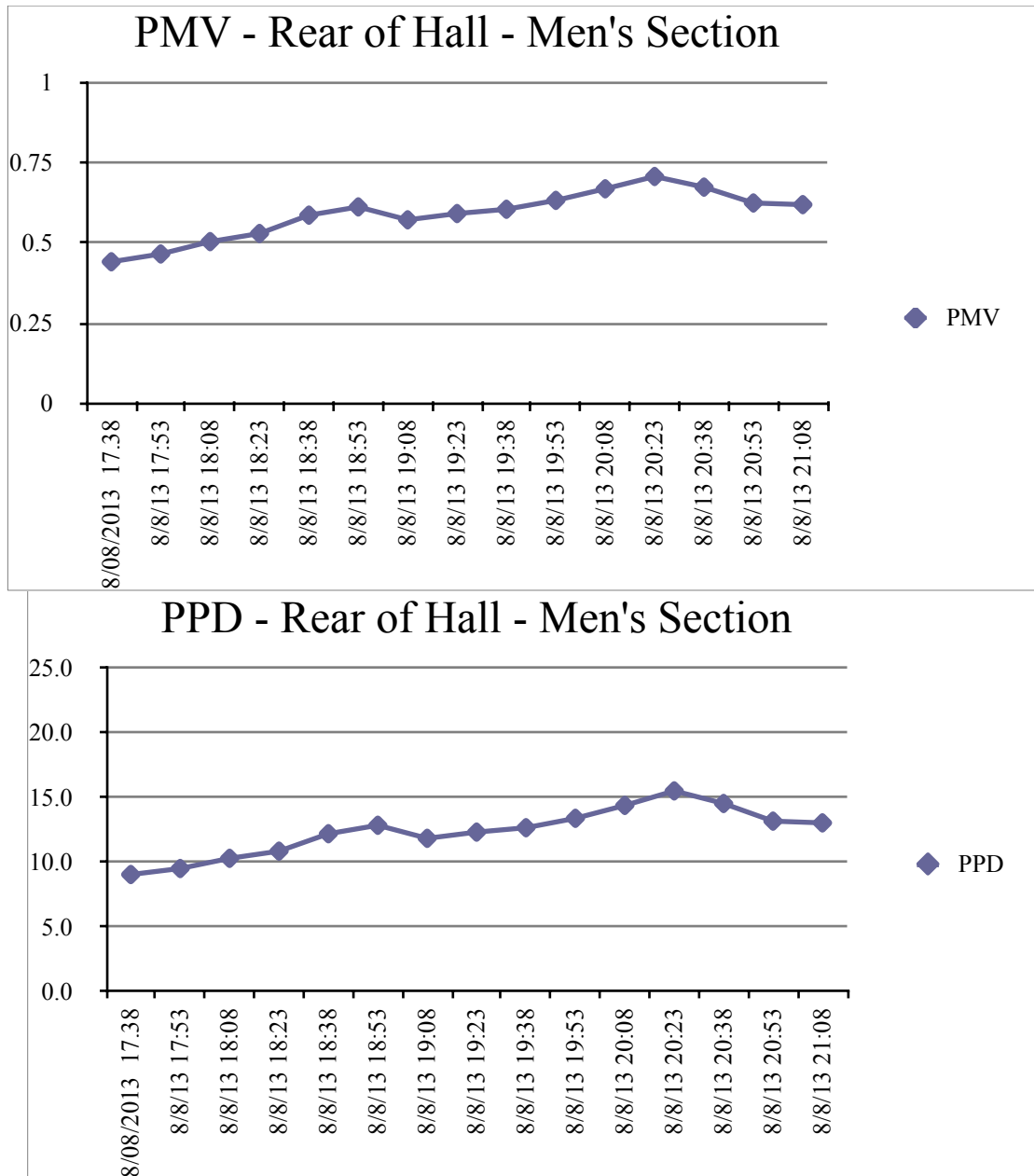

Fig 10 PMV & PPD - Men with Met = 1.2, Clo = 1.2, Air Vel = 0.4 m/s average (measured)

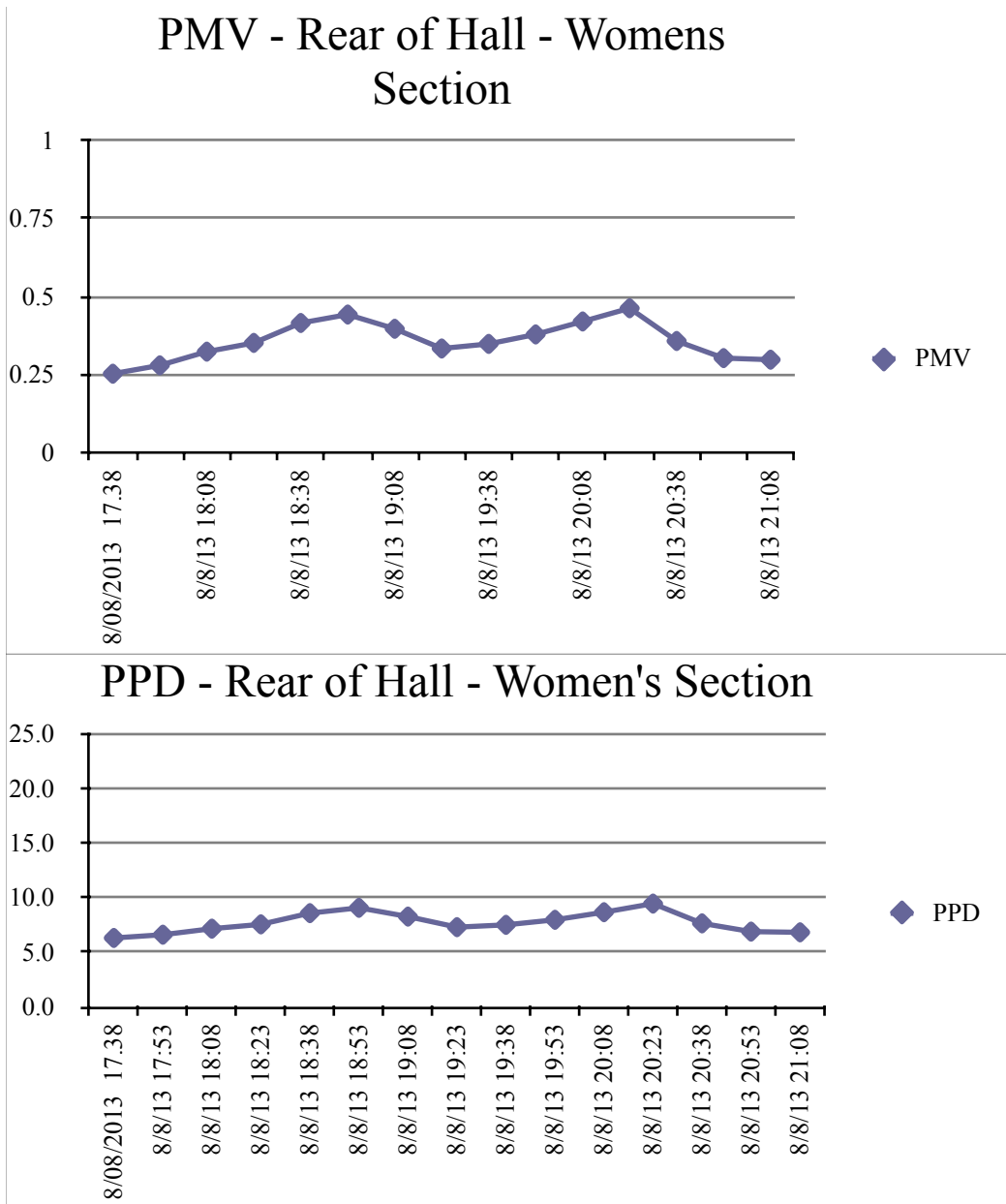

Fig 11 PMV & PPD - Women with Met = 1.2, Clo = 0.95, Air Vel = 0.4 m/s average (measured)

FRIDAY EVENING (TYPICAL) – Friday 9th August 2013

ATTENDANCE 305 OVERALL –155 WOMEN AND 160 MEN

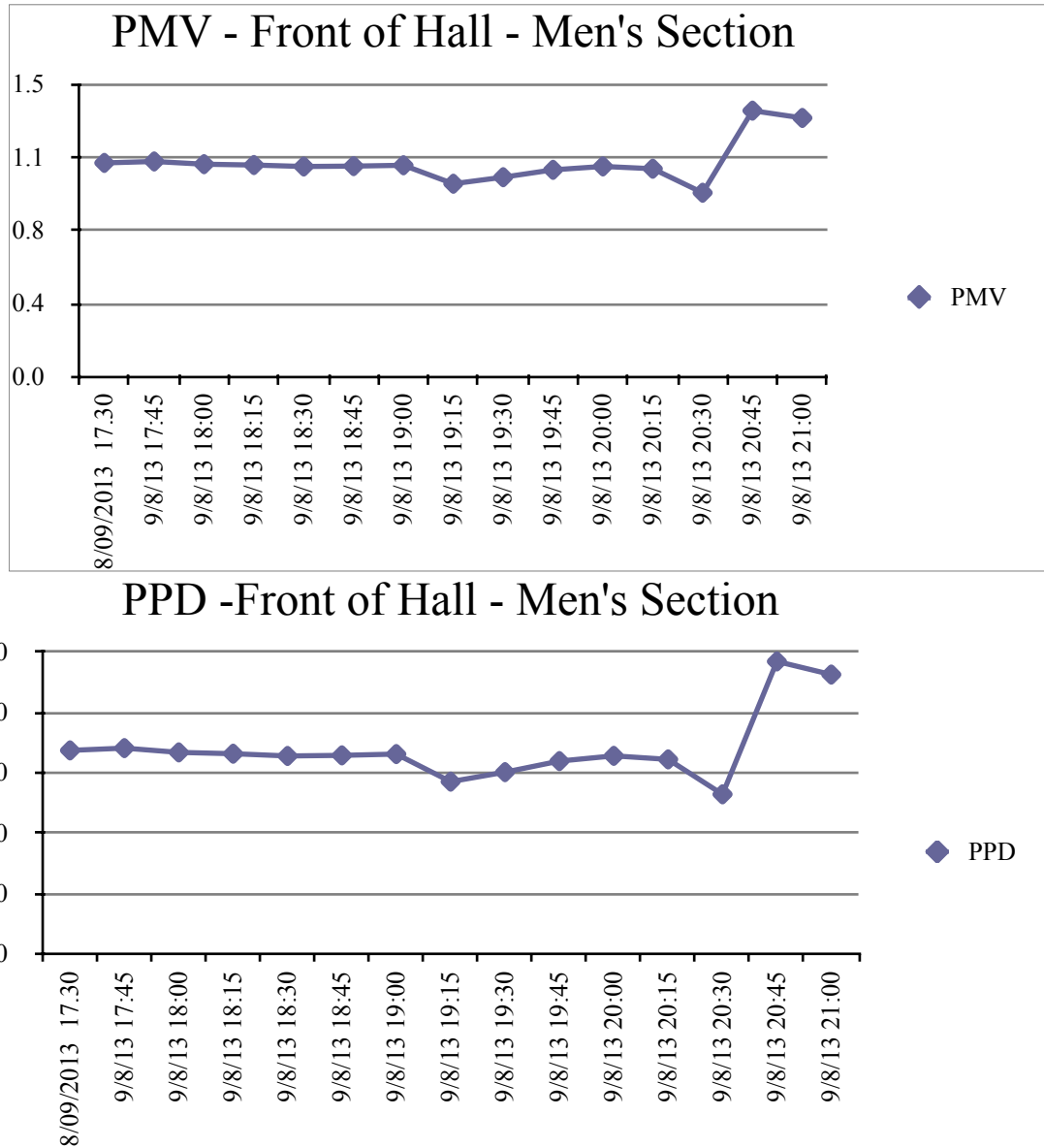

Fig 12 PMV & PPD - Men with Met = 1.2, Clo = 1.2, Air Vel = 0.1 m/s average (measured)

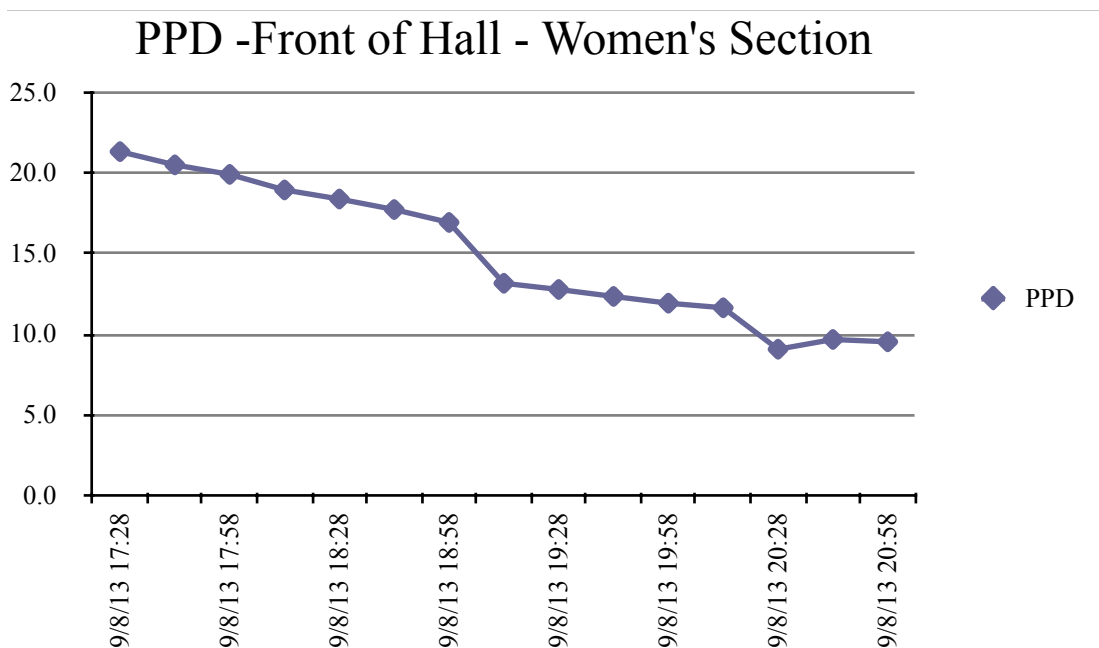
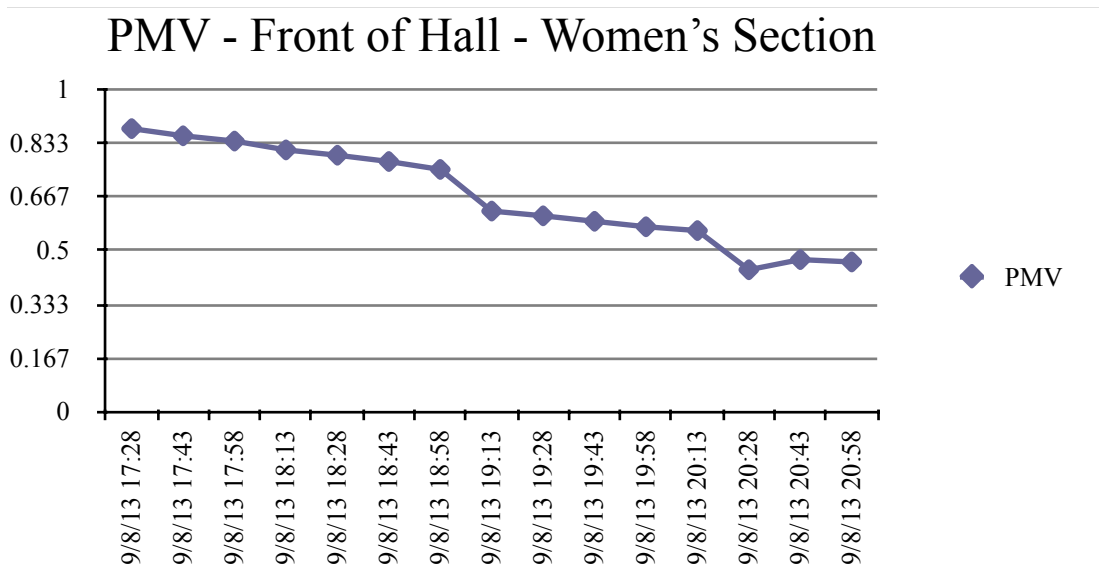

Fig 13 PMV & PPD - Women with Met = 1.2, Clo = 0.95 Air Vel = 0.1 m/s average (measured)

MIDDLE OF HALL - (as per figure 3)

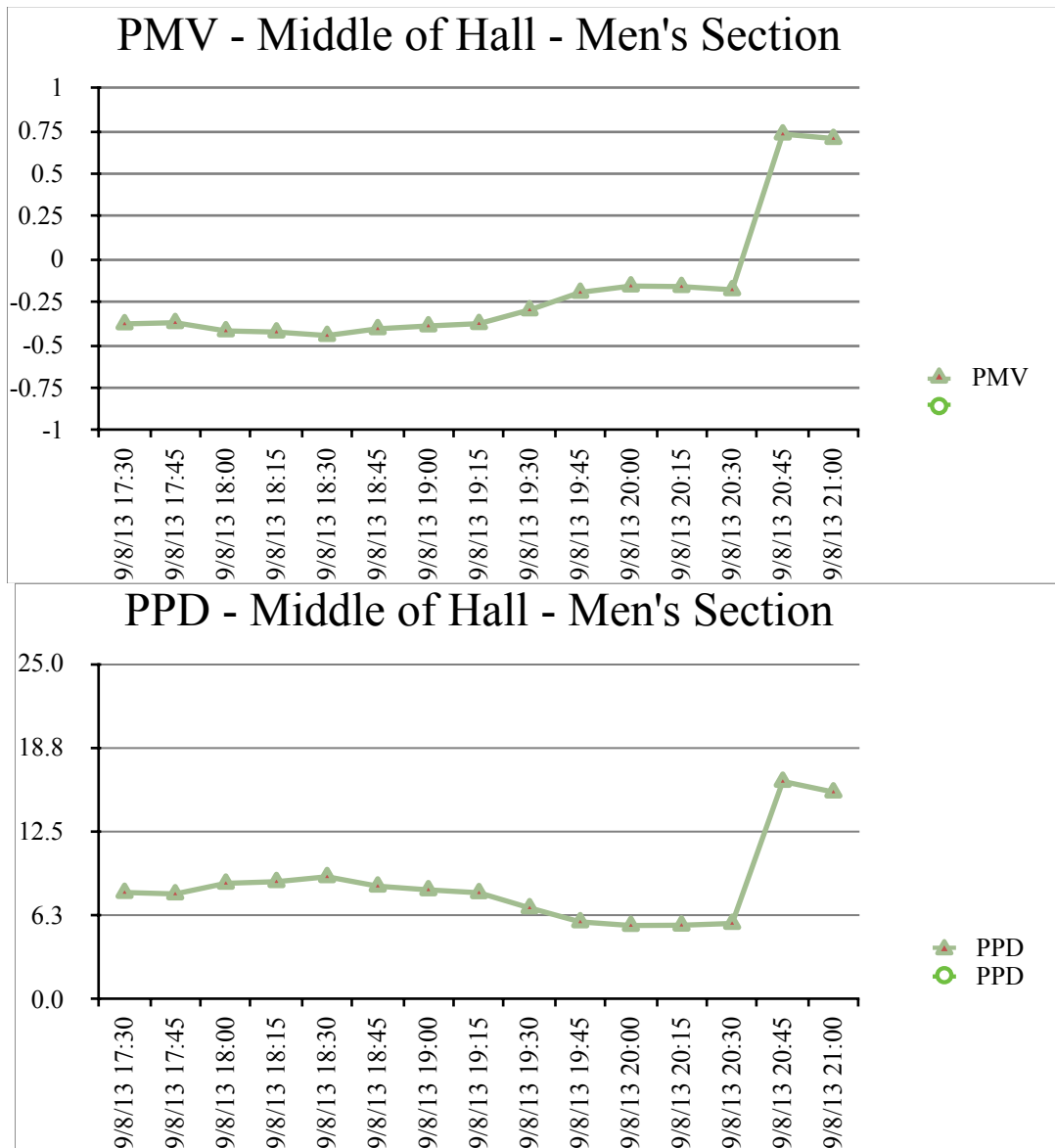

Fig 14 PMV & PPD - Men with Met = 1.2, Clo = 1.2 Air Vel = 0.21 m/s average (measured)

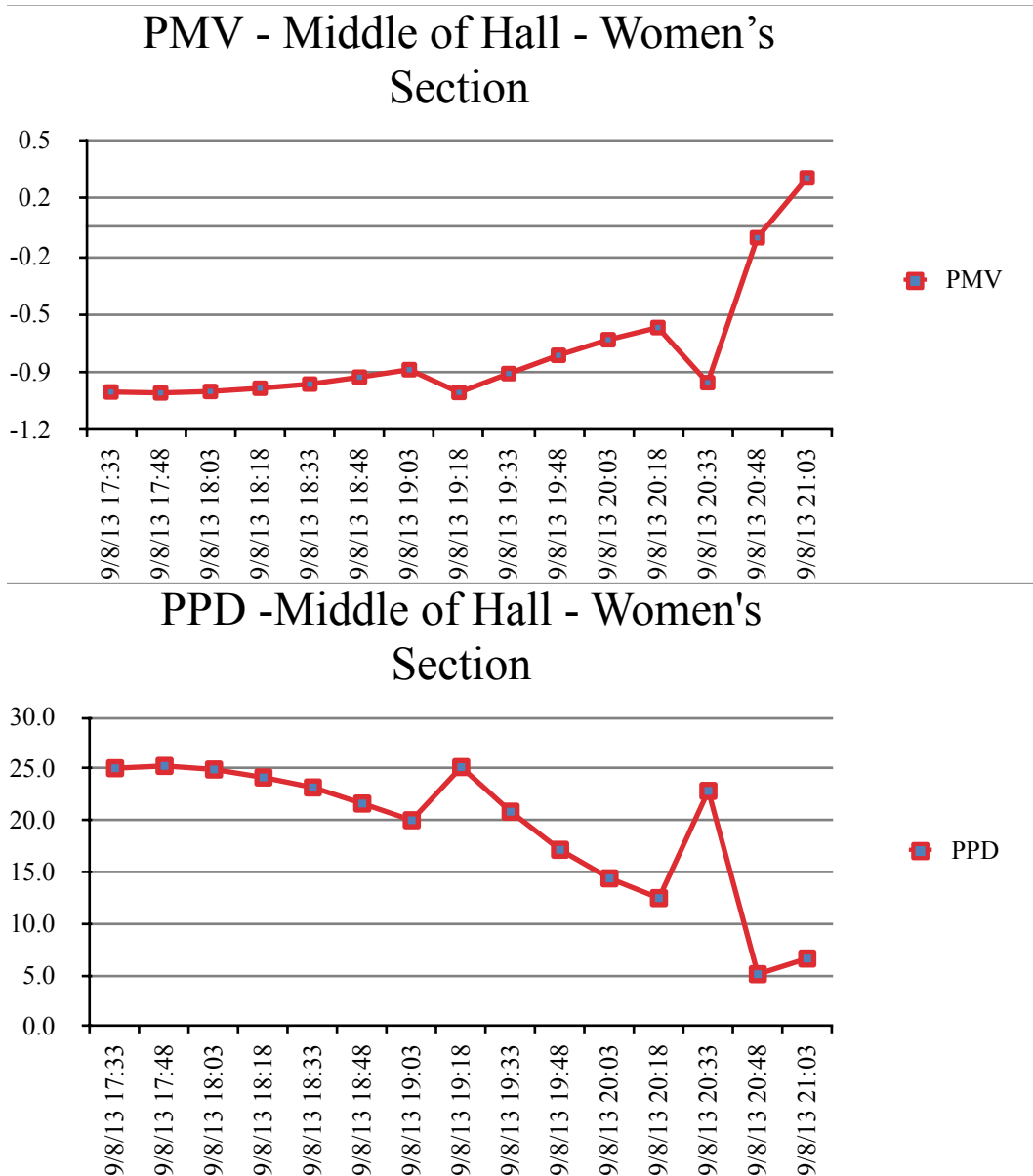

Fig 15 PMV & PPD - Women with Met = 1.2, Clo = 0.95 Air Vel = 0.21 m/s average (measured)

REAR OF HALL (as per Figure 3)

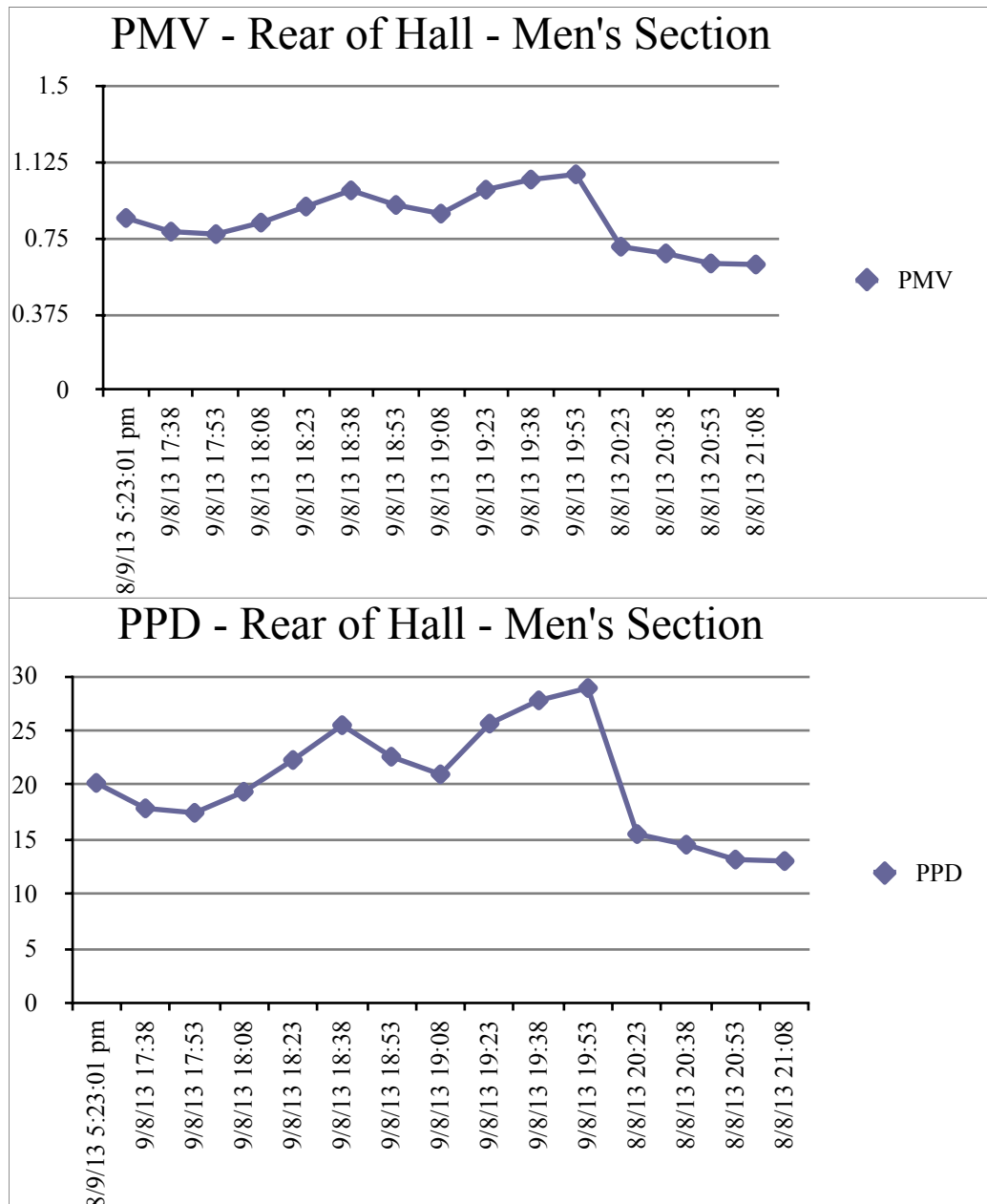

Fig 16 PMV & PPD - Women with Met = 1.15, Clo = 1.25 Air Vel = 0.4 m/s average (measured)

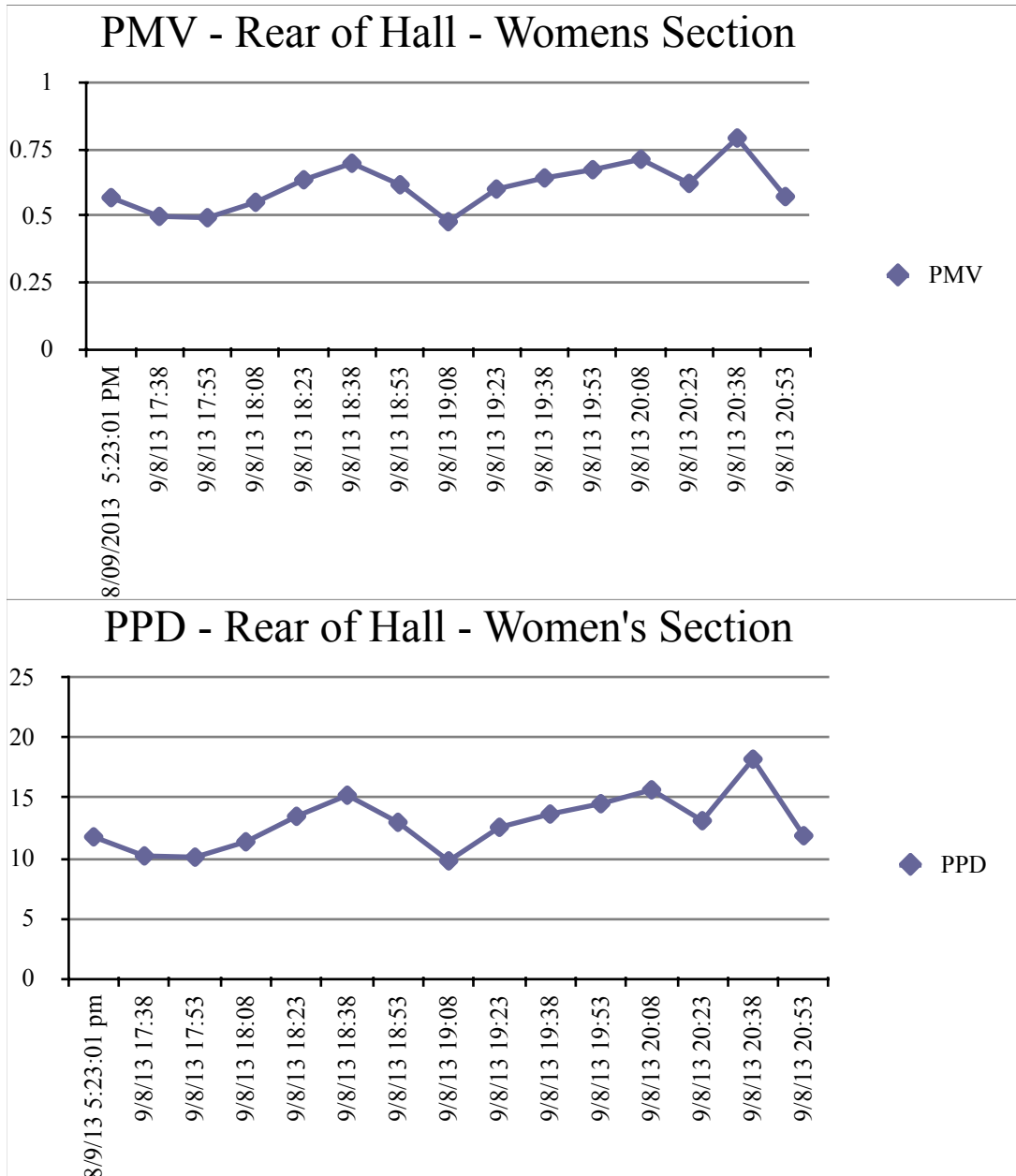

Fig 17. PMV & PPD - Women with Met = 1.15, Clo = 1.05 Air Vel = 0.4 m/s average (measured)

The findings have been very similar to the above. There were other evaluations carried out for the other weekday and weekend meetings.

WHAT DO THE RESULTS MEAN?

1. Temporary Free Standing Air Conditioning system, whilst providing some relief, is causing discomfort, especially for the men in general. Figs 6 & 12 highlight this - which is the result of lower air velocity and higher "clo" value for Men compared to Figs 7 & 13 which show reasonable PMVs and PPDs for women, especially as the evening progresses. Note: Figs 12 & 13 show a sudden increase in PMV and PPD at around 8.30 pm due to Air Conditioning Unit malfunction.
2. The elderly sitting at the rear of the Hall - especially men are uncomfortable due to relatively higher air velocities. This is evident in Figs 16 & 17 and in Figs 10 & 11. This indeed was the feedback from the Facility Manager.
3. Ingress of sunlight in early evening on the north- eastern area is a source of radiant heat (and radiant temperatures) which once again is a source of discomfort for the men sitting in the rear of the Hall. - as per Figs 10 & 16.
4. Outdoor temperature has an obvious impact on internal conditions – as seen from Friday results (Figs 12-17), when the outdoor temperature was 29.5 deg C. However since the peak attendances are generally in the evening, the dominant load is the internal loads and the fresh air load.
5. Clothing has a high impact on the comfort levels. The results clearly show that any future air conditioning will need to have the flexibility to set different temperature set points for men's and women's sections.
6. Uniform air distribution (appropriate velocity) is critical to attaining good comfort levels. This is evident with air flow variations from rear of the Hall to the front. It is therefore essential that future air conditioning system has the ability to provide uniform air flow – particularly in the area where the elderly are located.
7. As a result of the study, it was recommended that comfort become an equally important factor to aesthetics (and cost) when considering future air conditioning

NEW PROPOSED AIR CONDITIONING

The above recommendations have led to development of new air conditioning system, where comfort criteria have been applied.

A brief summary is provided as follows:

The proposed system is based on supply of conditioned air from the rear of the hall, via special Jet Diffusers – which are commonly used in air conditioning systems that require serving large open plan applications such as Theatres and Concert Halls. Since the air flow is only at the extreme left and right ends of the hall, the CFD evaluation is indicating that there is a need for some relief air at the rear of the hall to avoid a "dead zone" in the centre and rear

area, where the elderly sit on the chairs. This means that two fans with appropriate sound attenuators need to be housed in “bench like” structures in the courtyard.

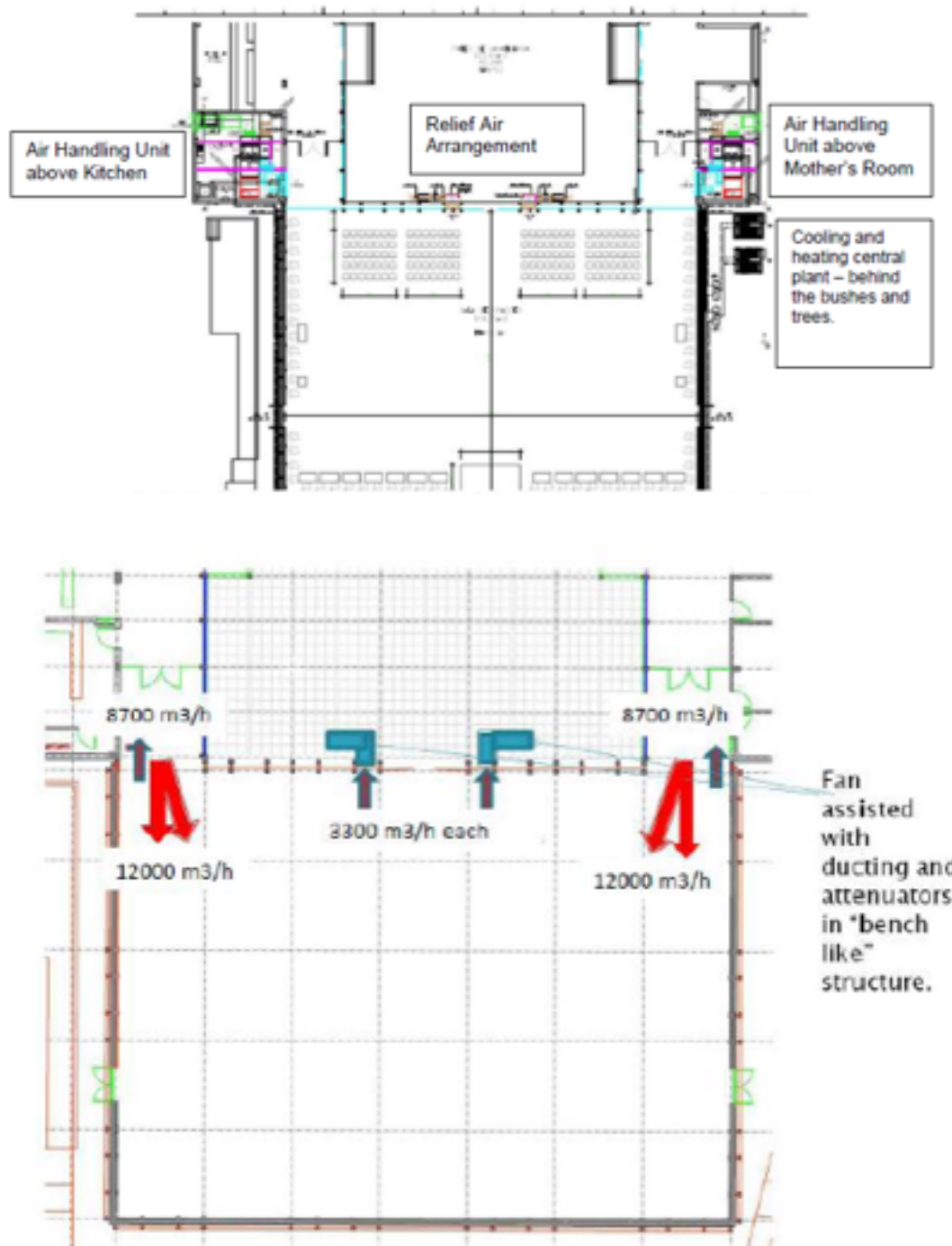

Fig 18 - New air quantities and arrangement of supply and relief



Fig 19 Proposed arrangement that will allow appropriate supply air distribution, as indicated by CFD.



Fig 20 - Mock up of "injector" type supply air outlets.

CFD EVALUATION SUMMARY

To evaluate the air and temperature distribution, Computational Fluid Dynamic (CFD) modelling was carried out using resources at the University.

The key analysis involved - With and Without the Relief Air System at the rear of the Hall.

SCENARIO 1 – WITH RELIEF AIR SYSTEM

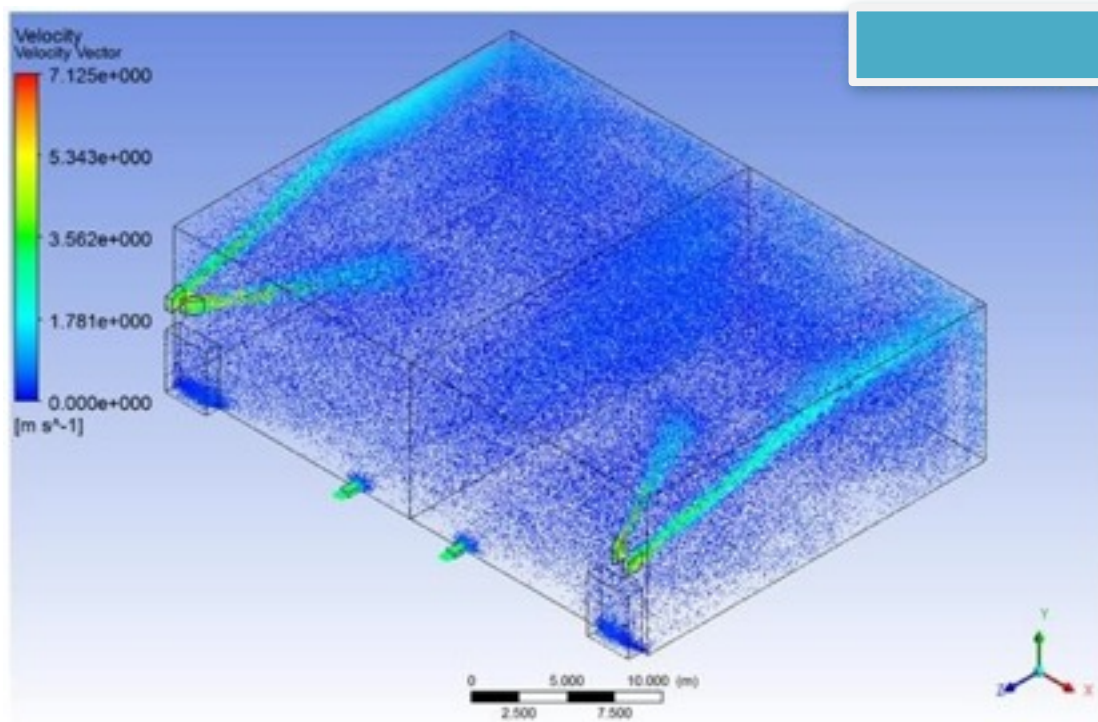

Fig 21 Airflow arrangement - **WITH RELIEF AIR SYSTEM**

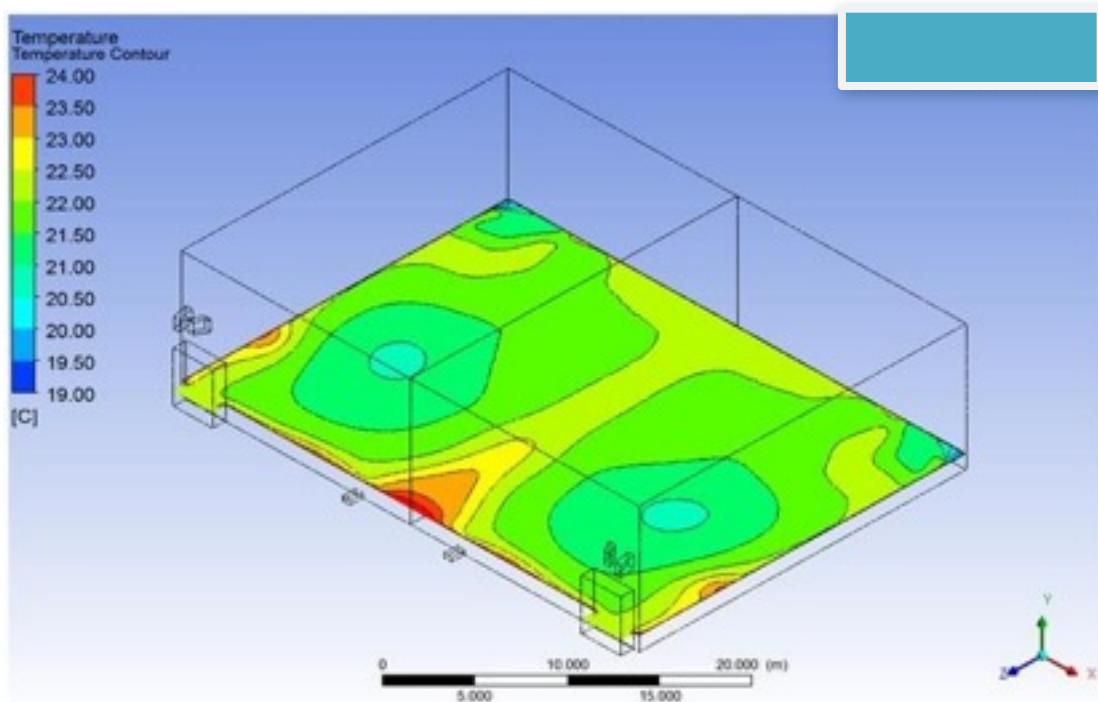

Fig 22 Temperature distribution – seated position (Y = 1.1 m) **WITH RELIEF AIR SYSTEM**

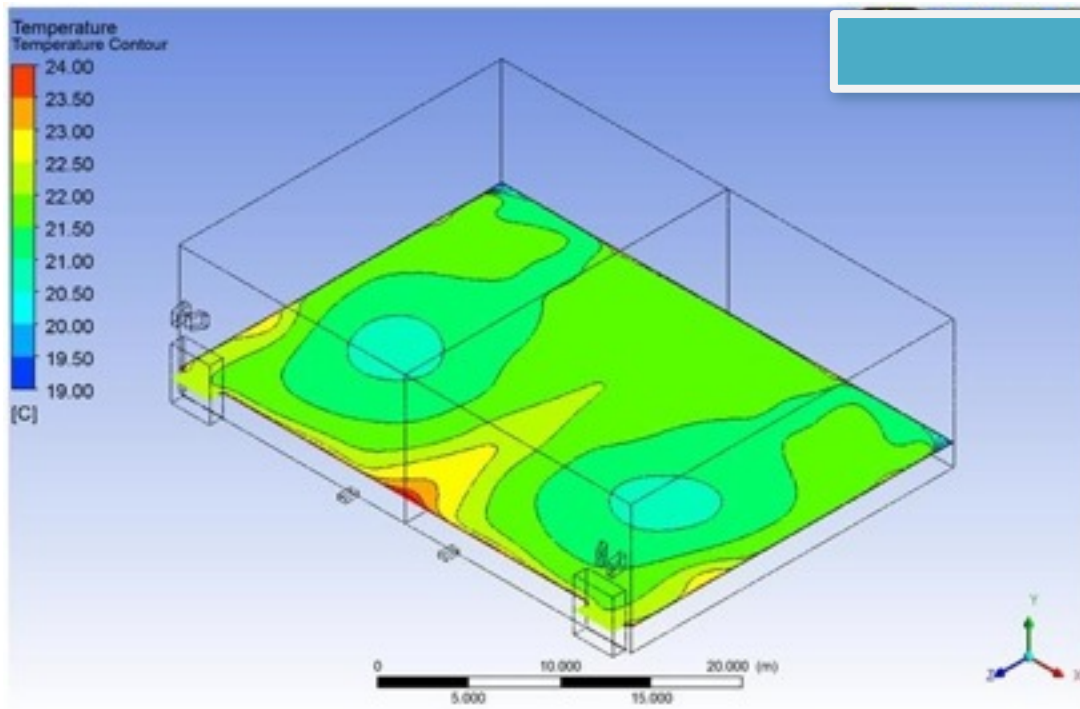

Fig 23 Temperature distribution – standing position ($Y = 1.7\text{ m}$) WITH RELIEF AIR SYSTEM

SCENARIO 2 – WITHOUT RELIEF AIR SYSTEM

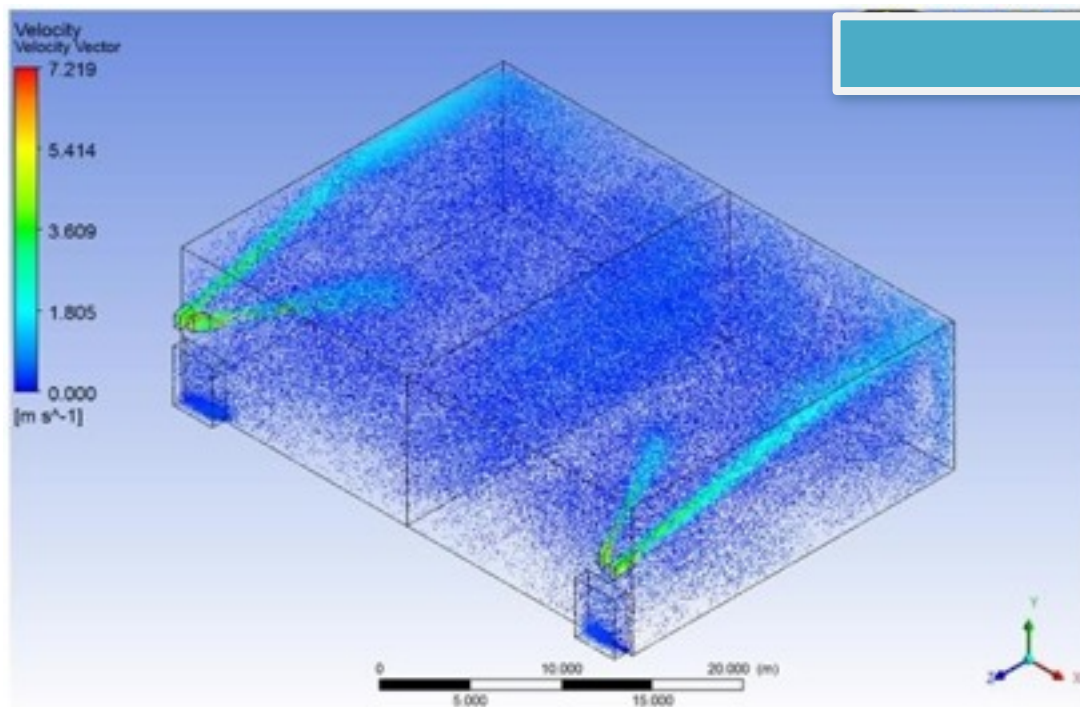

Fig 24 Airflow arrangement WITHOUT RELIEF AIR SYSTEM

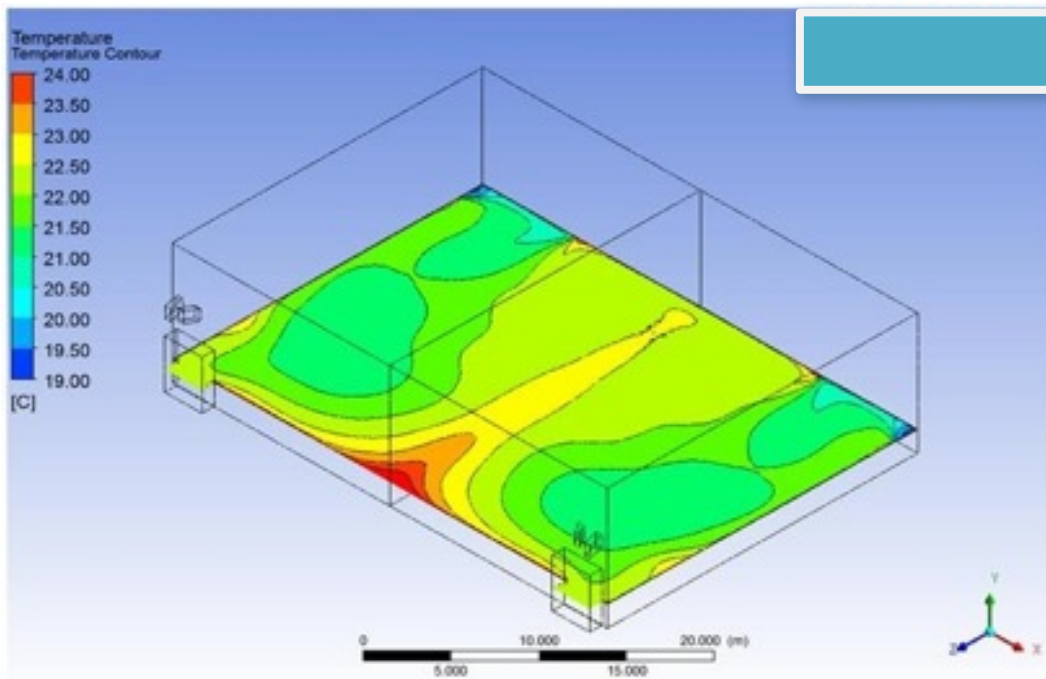

Fig 25 Temperature distribution – seated position ($Y = 1.1\text{ m}$) **WITHOUT RELIEF AIR SYSTEM**

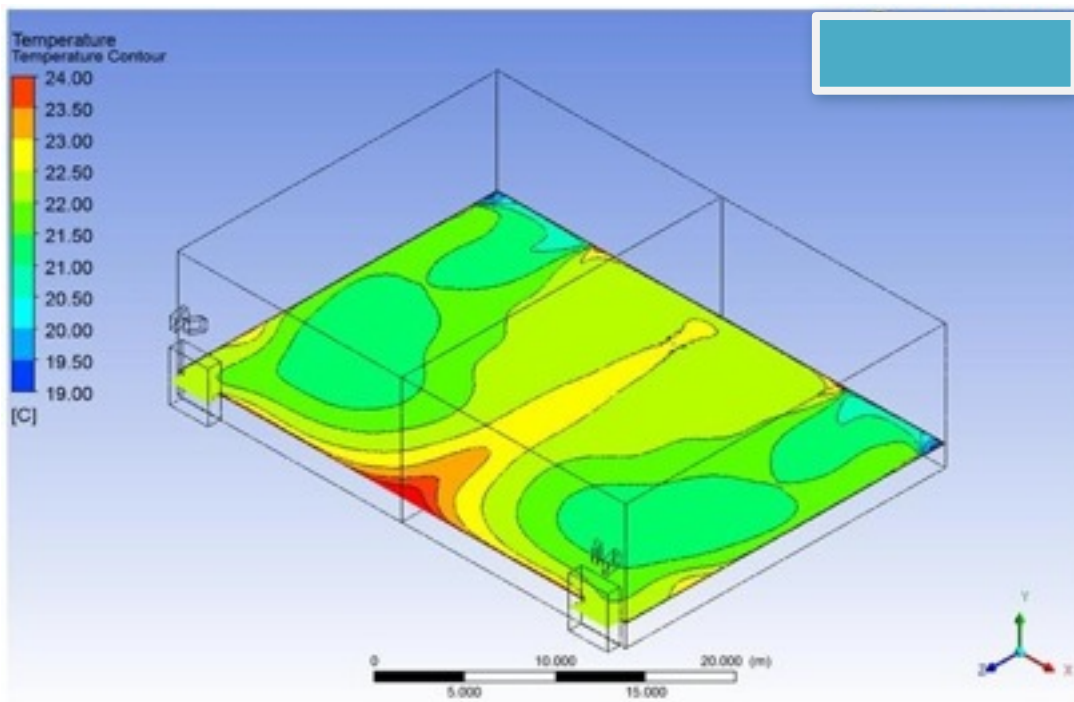

Fig 26 Temperature distribution – standing position ($Y = 1.7\text{ m}$) **WITHOUT RELIEF AIR SYSTEM**

CFD Output Discussion

Scenario 1 ,WITH Relief Air, decreases the temperature gradient to less than a degree and the velocity gradient to less than 0.2 m/s. This scenario therefore has a better chance of achieving more uniform air flow and hence better comfort conditions.

Scenario 2, WITHOUT Relief Air, clearly indicates higher temperature and velocity profiles in the centre especially towards the rear section. The temperature variation has been around 3 degrees (23 to 20 degrees C) whilst the velocity gradient has been around 0.4 m/s (0.5 to 0.1 m/s). This scenario has the potential to create discomfort conditions for occupants.

In summary, CFD results confirm the following:

- Jet Diffusers for injecting the conditioned air appear to be appropriate for such an application,
- Jet Diffusers need to be set up with the angles as per the CFD modeling,
- Relief Air system is necessary to provide uniform air and temperature distribution

Comfort Evaluation Benefits

To cater for the gender differences, as confirmed by the comfort evaluation, the conditioned air to the men's and women's sections will be able to be set independent of each other. To address the age difference, which was also evident in the comfort analysis, the return and relief air arrangement will enable the zone temperature to be higher at the rear section of the hall, where the elderly sit.

VANCOUVER CENTRE

Purpose built in 1988 – with 25M X 25M prayer hall, where temperature and humidity recordings were taken over the same period as for Lisbon Centre - August 2013;



Fig 27 Prayer Hall – Men's Section – Women's Section identical on left hand side.



Fig 28 Chairs at the rear for the elderly – Men and Women

Comfort evaluations were carried out during the same time period as for the Lisbon Centre with data collected for similar events.

Background information:

- › Central Air Conditioning System – comprising Air Handling Units, Chillers and Boilers located in the Basement. Air Velocity average = 0.25 m/s (as provided by the Facility Manager).
- › Recently the control system has been upgraded with the change from Pneumatics to Direct Digital Controls. There appear to be certain parameters that are still left with manual overrides – particularly temperature set-points.
- › A better indoor environment is necessary taking into account the aging population, which is more regular in prayer meetings

Locations of data loggers – in the form of I - Buttons

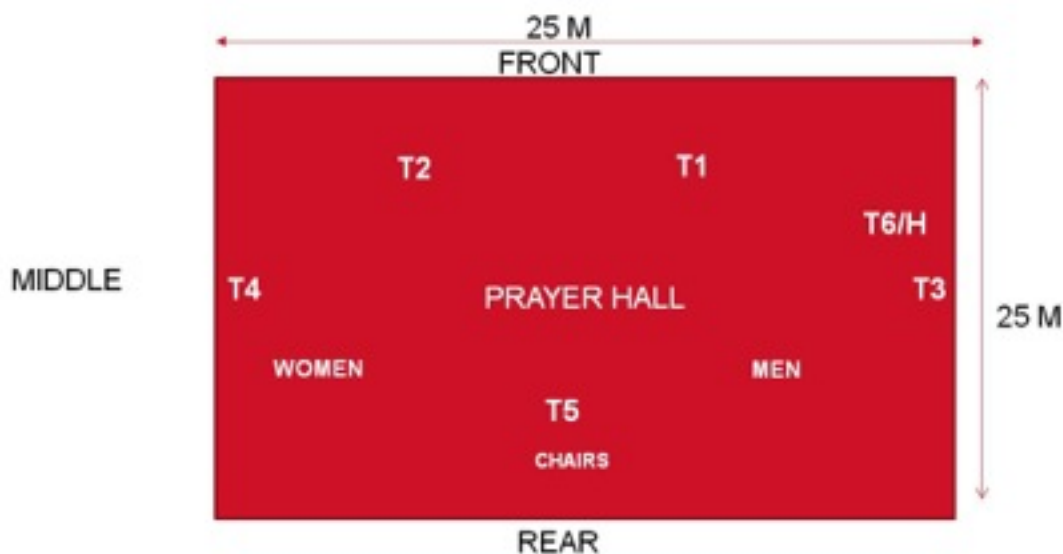

Fig 29 - Plan - Vancouver Centre showing I-Button locations

Parameters

- › Air Temperature – Degrees C – as per I-Buttons
- › Humidity – %RH – as per I-Buttons.
- › Air Flow — based on Central Air Conditioning System – comprising Air Handling Units, Chillers and Boilers located in the Basement. Air Velocity average = 0.25 m/s (as provided by the Facility Manager).
- › Activity – Meditation / Prayers - Met = 1.2 – elderly = 1.15
- › Clothing – Men wearing coats / suits – Clo = 1.2 – elderly on chairs = 1.25
Women wearing dresses, saris, etc – Clo = 0.95 - elderly on chairs = 1.0



Fig 30 - I-Button

Women utilize shawls to cover their shoulders – particularly for early morning prayers.

in that case the “clo” value is increased to 1.05

- › Radiant Temperature — based on sunlight (minimal) entering certain parts of the Hall. Most Prayers being in the evening and early morning the impact is minimum.

›

FESTIVAL EVENING – Wednesday 7th August 2013

ATTENDANCE 1095 OVERALL – 535 WOMEN AND 560 MEN

FRONT OF THE HALL

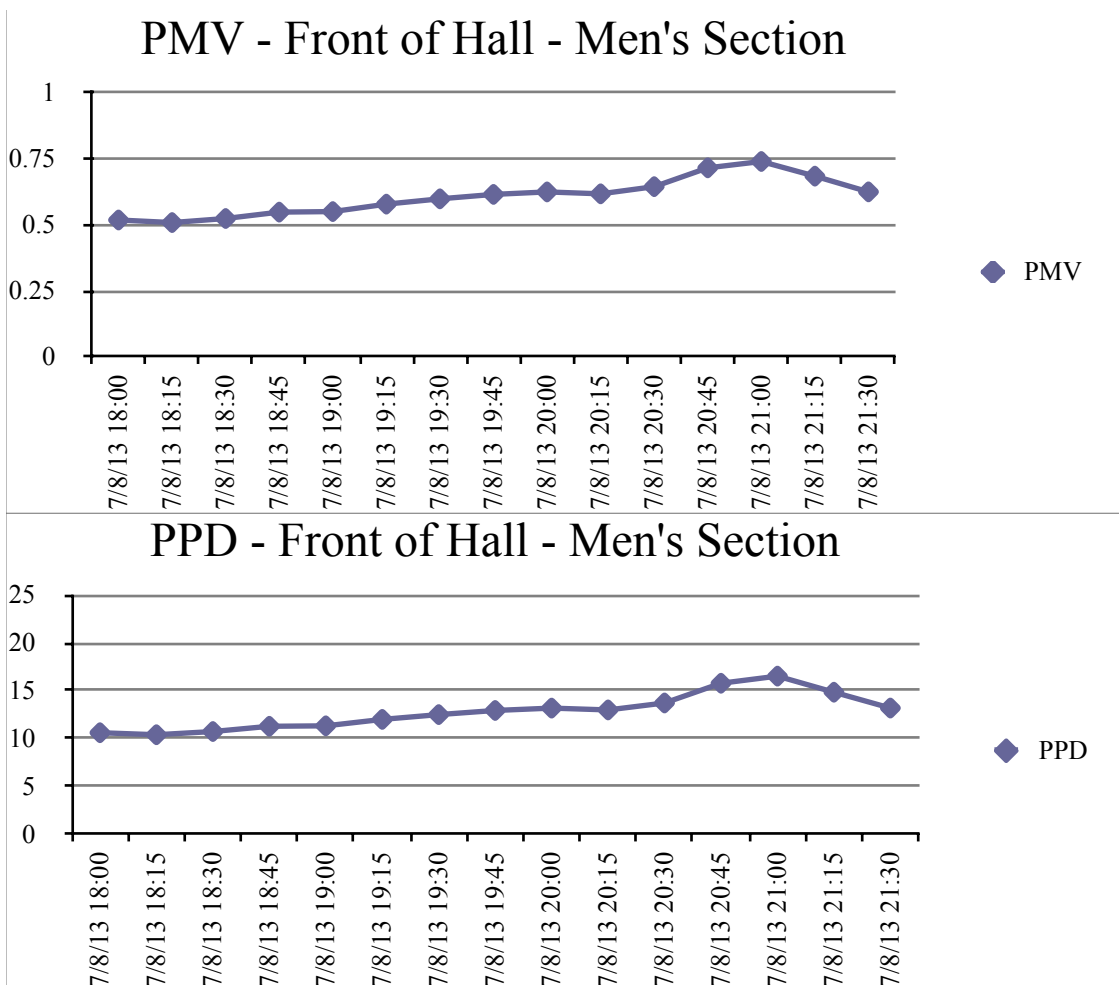

Fig 31 PMV & PPD - Men Met = 1.2, Clo = 1.2, Air Vel = 0.25 m/s average (as provided by the Facility Manager)

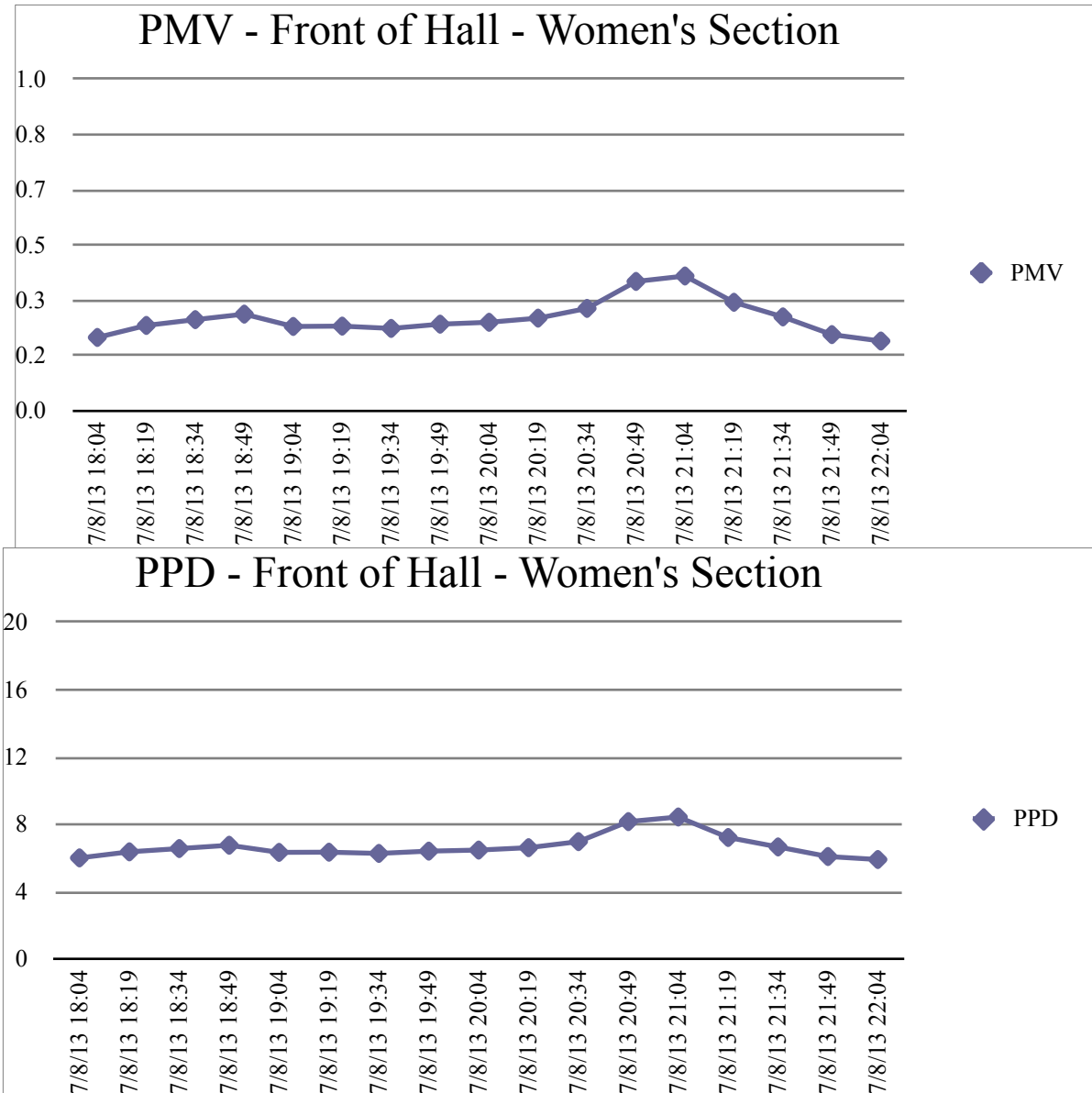

Fig 32 PMV & PPD Women - Met = 1.2, Clo = 0.95 Air Vel = 0.25 m/s average (as provided by the Facility Manager)

MIDDLE OF THE HALL

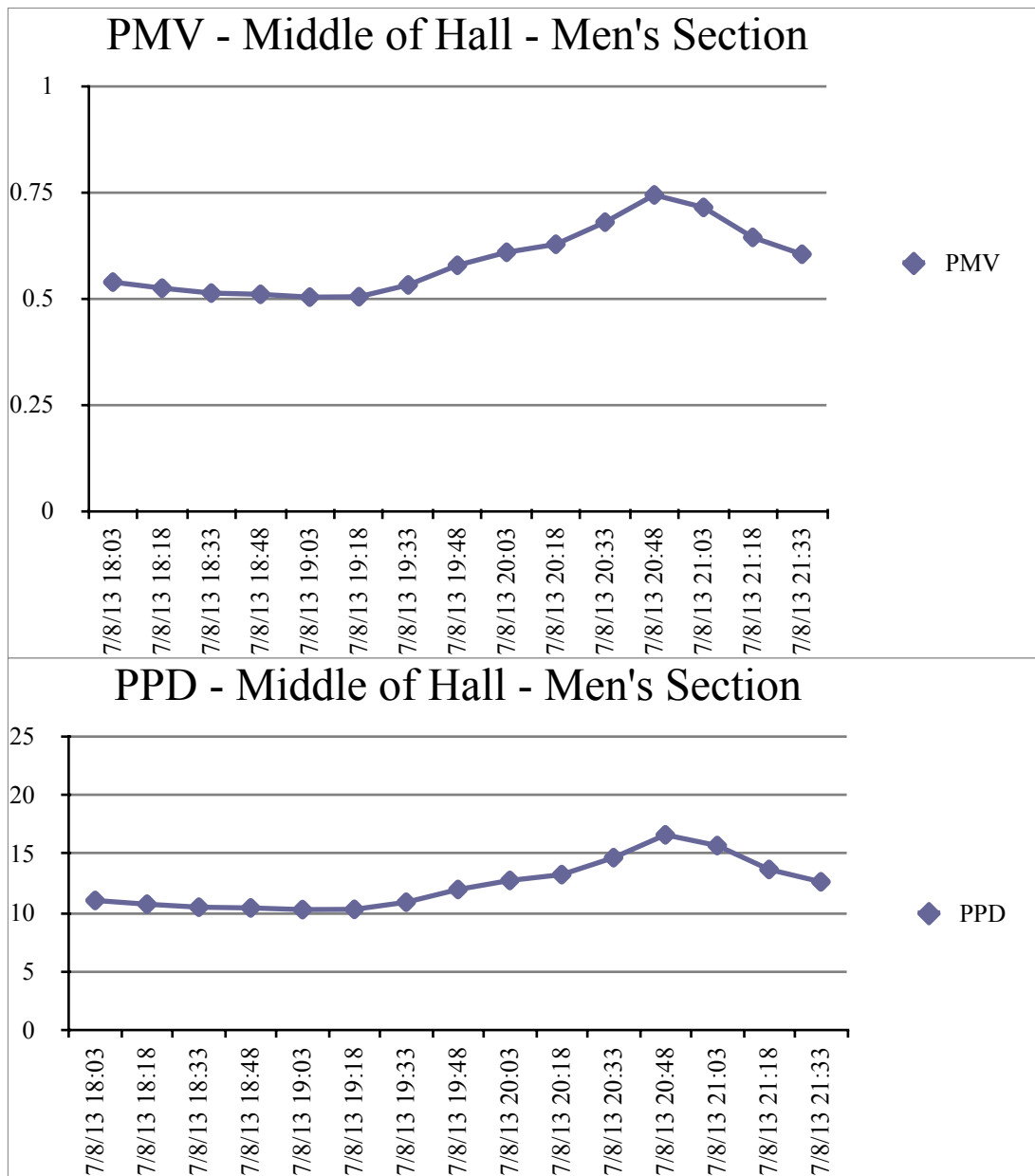

Fig 33 PMV & PPD - Men - Met = 1.2, Clo = 1.2, Air Vel = 0.25 m/s average (as provided by the Facility Manager)

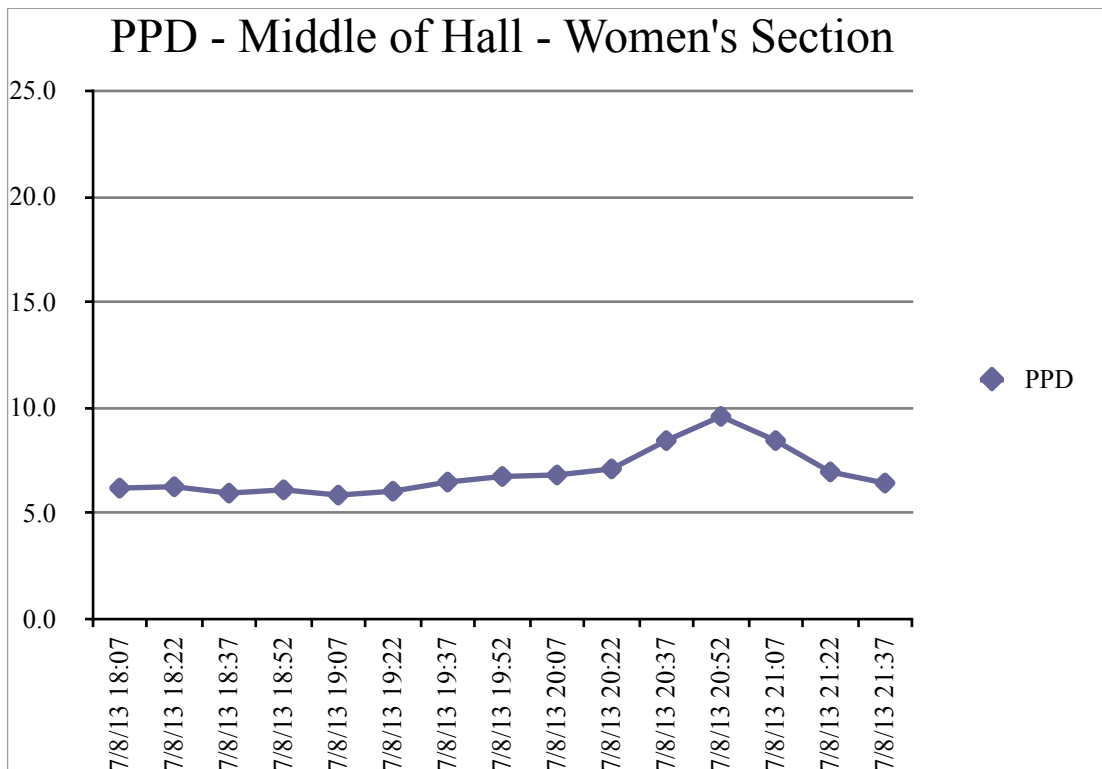
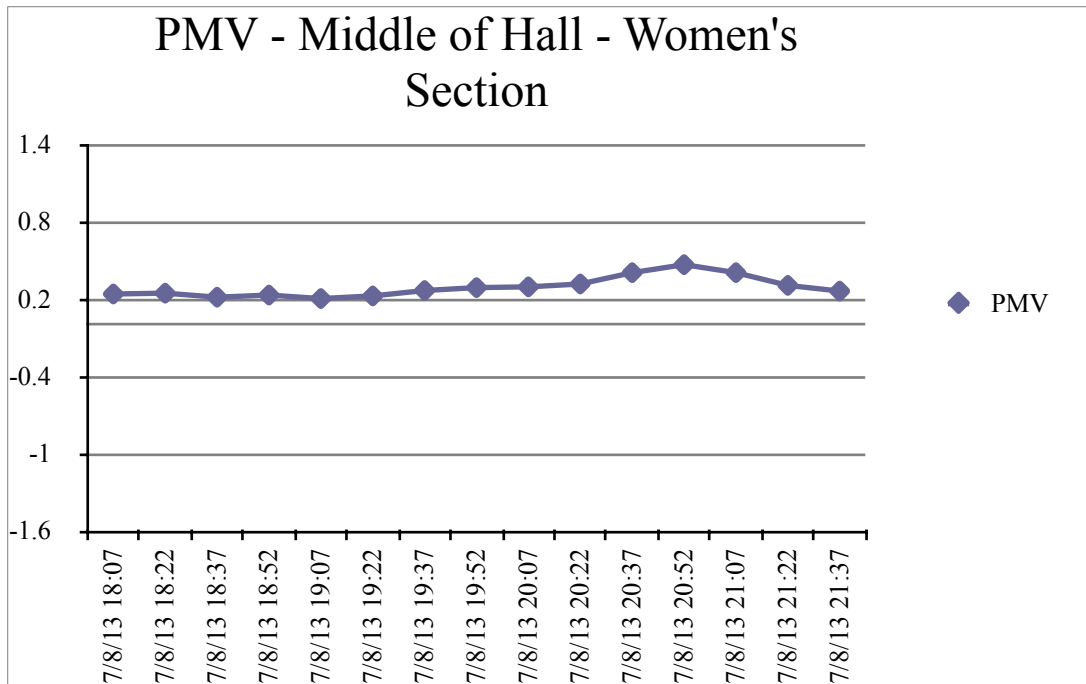

Fig 34 PMV & PPD - Women Met = 1.2, Lc = 0,95 Air Vel = 0.25 m/s average (as provided by the Facility Manager)

REAR OF THE HALL

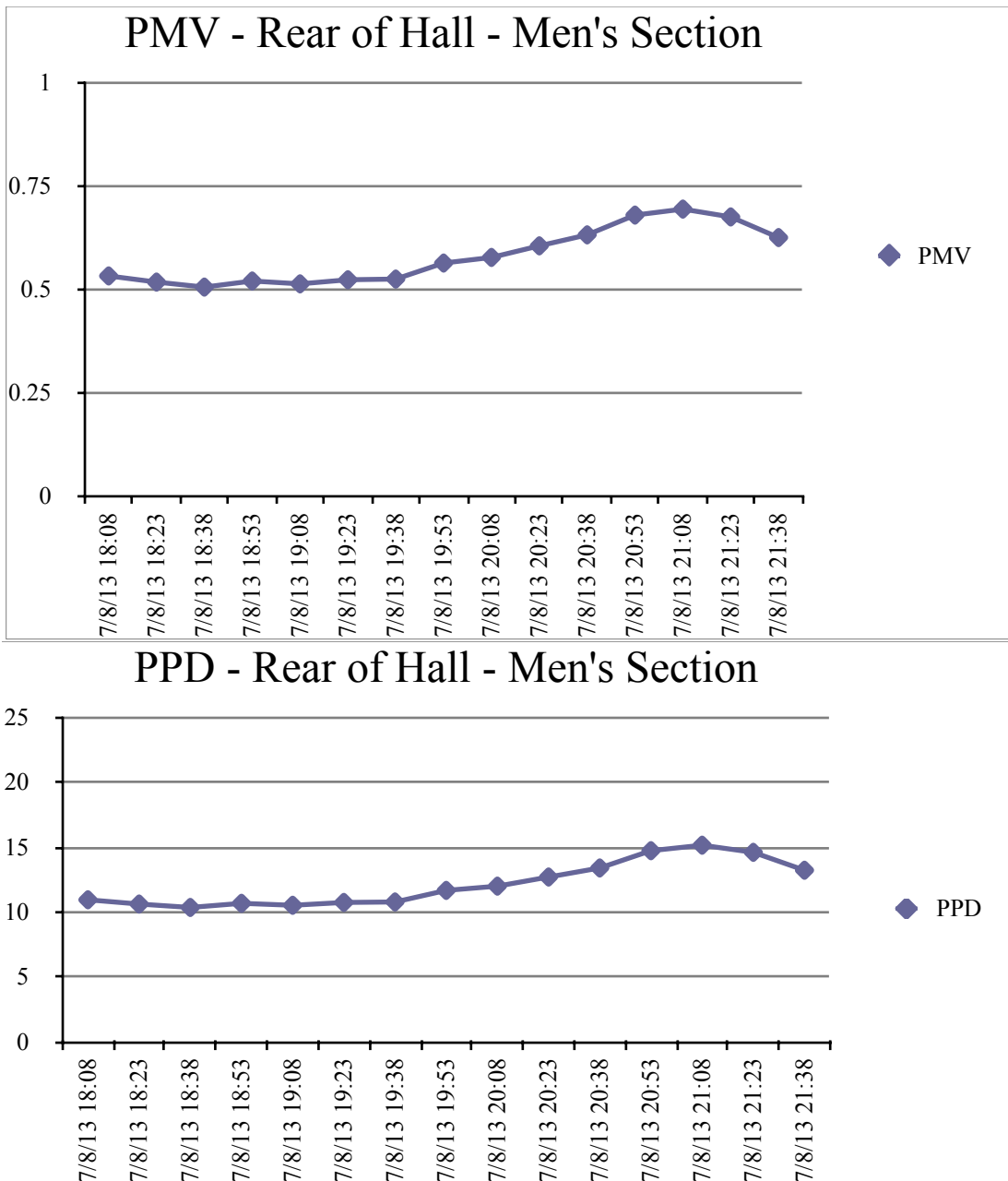
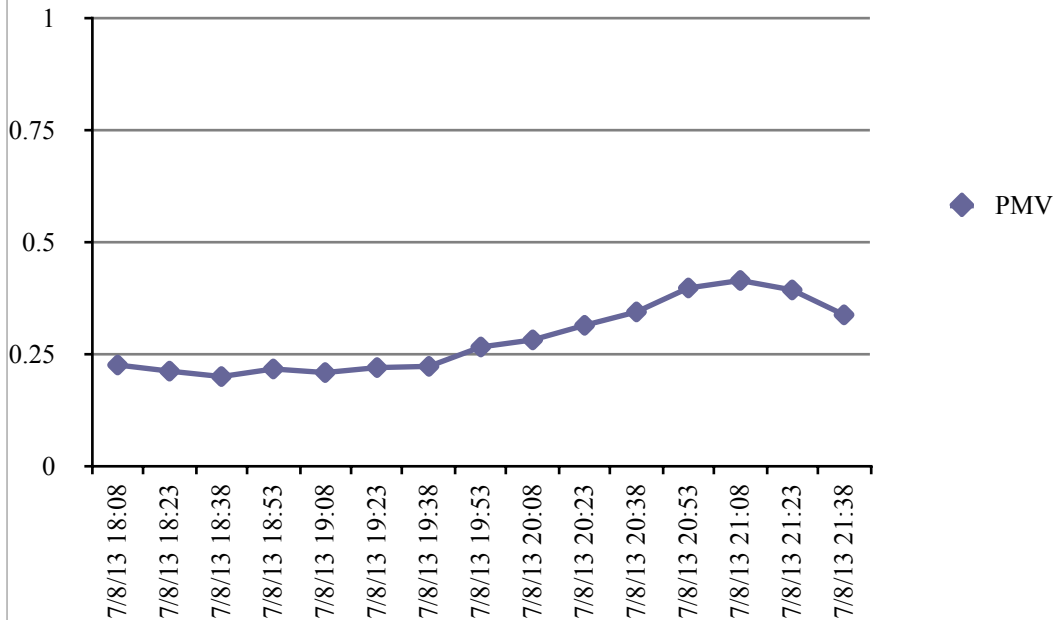

Fig 35 PMV & PPD - Men - Met = 1.15, Clo = 1.25, Air Vel = 0.25 m/s average (as provided by the Facility Manager)

PMV - Rear of Hall - Women's Section



PPD - Rear of Hall - Women's Section

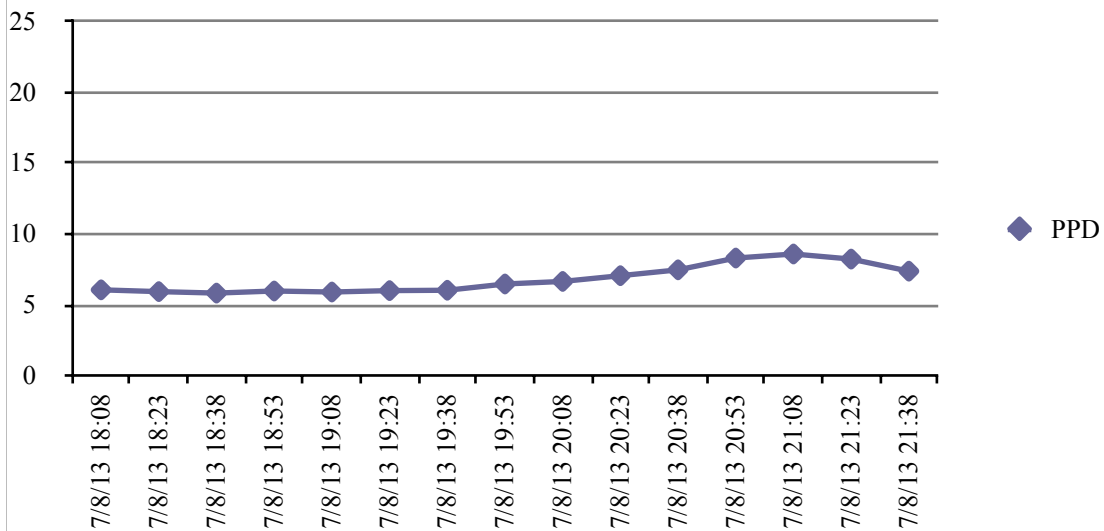

Fig 36 PMV & PPD - WOMEN - Met = 1.15, Clo = 1.0, Air Vel = 0.25 m/s average (as provided by the Facility Manager)

EARLY MORNING – Sunday 11th August 2013

ATTENDANCE 110 OVERALL – 60 WOMEN AND 50 MEN

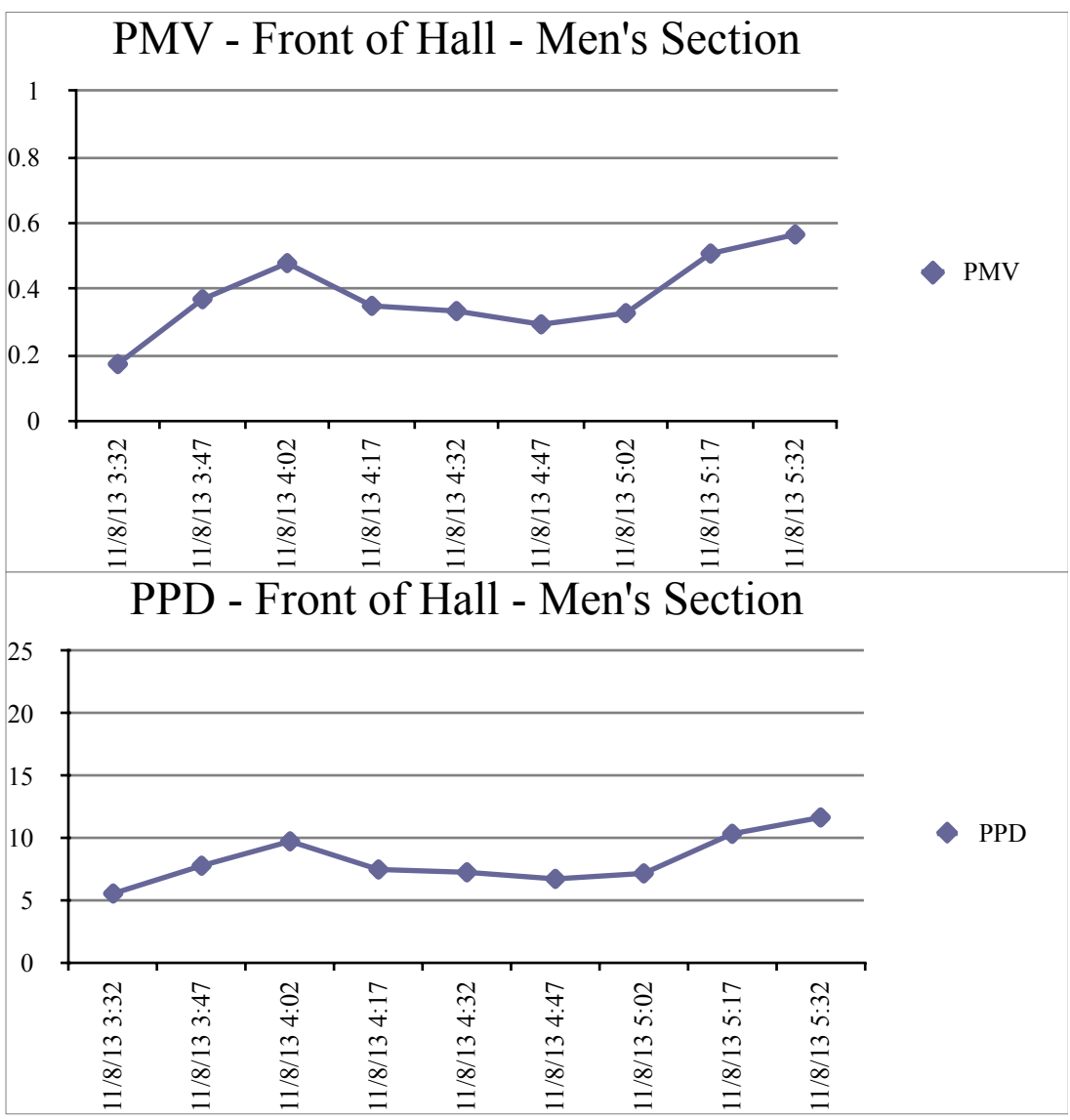

Fig 37 PMV & PPD - Men - Met = 1.0 Meditation, Clo = 1.15 light jackets Air Vel = 0.25 m/s average

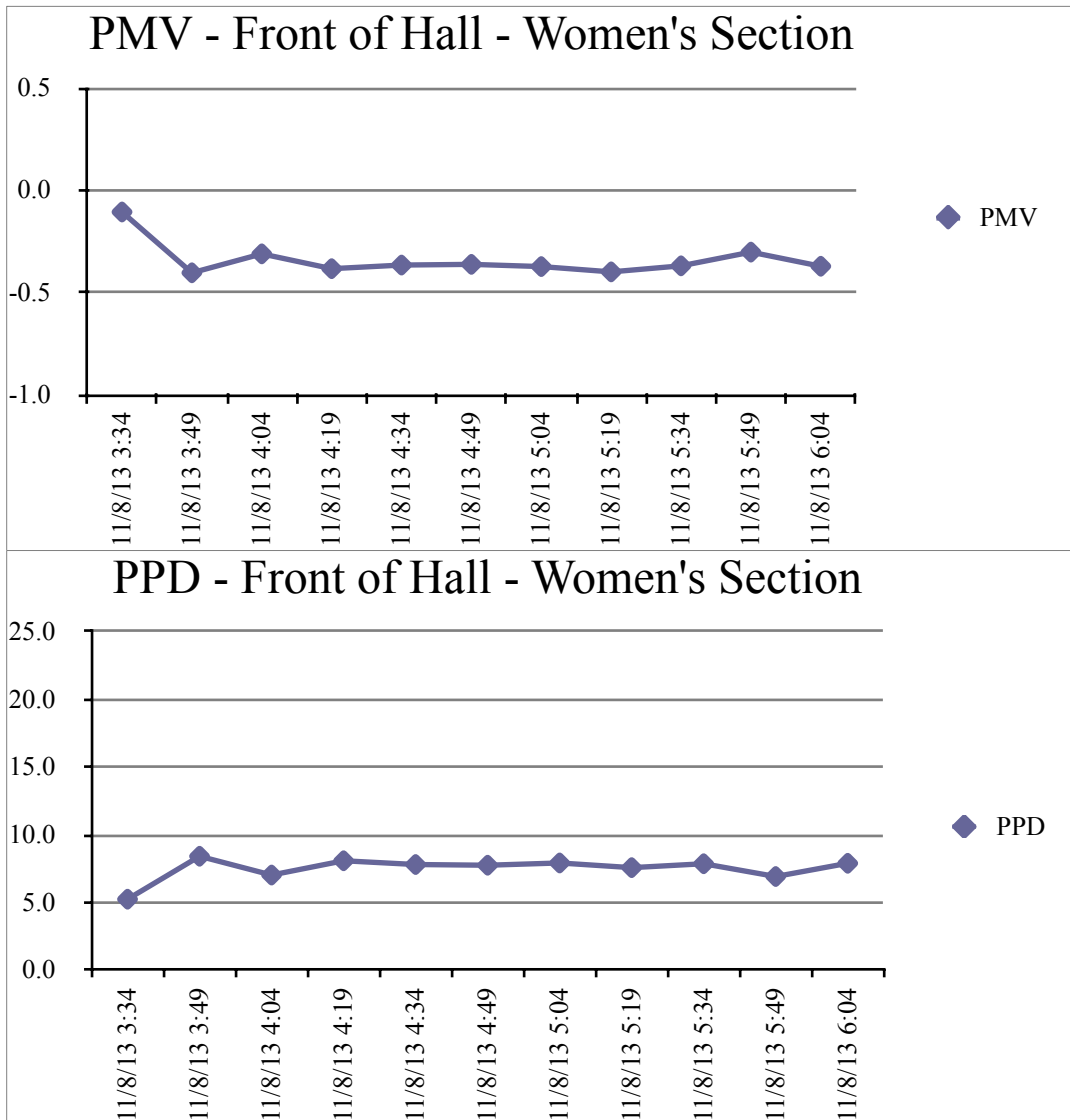

Fig 38 PMV & PPD Women - Met = 1.0 Meditation, Clo = 1.05, Air Vel = 0.25 m/s average

WHAT DO THE RESULTS MEAN?

1. PMVs & PPDS are higher for men as per Figs 31,331 & 35 as oppose to women as per Figs 32, 34 & 36 mainly due to clothing value differences. The temperature set points for men and women sections are kept at same values.
2. The results clearly show that the air conditioning controls need to have the flexibility to set different temperature set points for men's and women's sections.
3. The early morning meeting - where mostly the congregation all sit at the front show that PMV and PPD values are slightly higher for men (fig 37) when compared to women (fig 38). In this case the women do have shawls.
4. Impact of Shawls for women is noticeable – approx 2.5 variation in PPD.

PROPOSED AIR CONDITIONING ENHANCEMENT

The above recommendations have led to discussions with the Controls firm to enable automatic adjustment of set points for morning and evening prayers. The ability to manually adjust temperature set-points has also been removed.

OVERALL CONCLUSION

The evaluations carried out for these two centers ,over the same time period show clearly that there is a significant impact of the respective air conditioning systems on men and women.

In Lisbon Centre, the highest variation in PPD range for men compared to women on Festival Day, at the Front of the Hall, range from 5 points at the start of the meeting to around 17.5 points at the conclusion of the meeting. These values decrease for the Middle and Rear Sections. The key factors are the obvious different “clo” values and the fact that the location of the temporary air conditioning is inappropriate. The cooling capacity, too, is also questionable.

The Friday results show increased (and erratic) variations in PPD values and on further examination, it was pointed out by the Facility Manager that one of the four temporary air conditioning units had failed. The PPD difference for men and women was still noticeable.

The impact on elderly at the rear of the Hall is 10 PPD points less than for Men and around 5 PPD points for the Women at the Front. This is mainly due to increased air flow at the rear of the Hall

In Vancouver Centre, the highest variation in PPD range for men compared to women on Festival Day, at the Front of the Hall, range from 5 points at the start of the meeting to around 10 points at the conclusion of the meeting. These values decrease for the Middle and Rear Sections. The key factors are the obvious different “clo” values since the air flow is similar for all section – being centrally air conditioned.

The impact on elderly at the rear of the Hall is 3 PPD points less than for Men and around 2 PPD points less for the Women at the Front. This confirms that with uniform air distribution, there would be minimal PPD differences.

The Early Morning congregation results show that there is a variation of around 2.5 points on average for when women use the shawls to cover themselves to if no shawls were to be employed. Once the control set points for men and women areas are adjusted (automatically – depending on the outside air temperature) the need for shawls may be decreased.

The PPD variation between the men and the women at the Front of the Hall is marginal.

Comfort evaluations, in both cases, is leading to adoption of enhanced air conditioning systems.

References

- Al-Ajmi, F.F. (2006), Thermal insulation of Arabian Gulf men's clothing: Measurements using a thermal manikin, *ASHRAE Transactions*, 112 (2), 240-244.
- Al-Ajmi, F.F. (2010), Thermal comfort in air conditioned mosques in the dry desert climate, *Building and Environment*, 45, 2407-2413.
- Brager, G.S.; Fountain, M.E; Benton, C.C.; Arens, E.A. and Bauman, F.S. (1993), A comparison of methods for assessing thermal sensation and acceptability in the field. *Conference Proceeding: Thermal comfort: Past, Present and Future*, ed. Oseland, N. Building Research Establishment, 17-39, Watford, UK, 9-10 June 1993.
- Humphreys, M. (1977), The optimum diameter for a globe thermometer for use indoors. *Annual Occupational Hygiene*, Vol. 20, pp. 135-140.
- Humphreys, M. and Nicol, F. (2002), The validity of ISO-PMV for predicting comfort votes in every day thermal environment. *Energy and Buildings*, Vol. 34, pp. 667-684.
- ISO 7726. (1998), Ergonomics of the Thermal Environment- Instruments for Measuring Physical Quantities. Geneva, Switzerland: International Organization for Standardization.
- Kotbi, M.; King, S. and Prasad, D. (2012), How to test Fanger's PMV model in a field study?, *Proceeding of Conference, Adapting to Change: New Thinking on Comfort*, Windsor, UK, 9-11 April 2012.
- Mohammad S. Al-Homoud (2009) Envelope Thermal Design Optimization of Buildings with Intermittent Occupancy - *Journal of Building Physics* 2009 33: 65

Thermal comfort in primary schools: a field study in Chile

Maureen Trebilcock¹, Jaime Soto² and Rodrigo Figueroa³

1 Department of Architectural Design and Theory, Universidad del Bío-Bío, Concepción, Chile, email: mtrebilc@ubiobio.cl

2 Department of Building Science, Universidad del Bío-Bío, Concepción, Chile, email: jsotom@ubiobio.cl

3 CITEC UBB, Universidad del Bío-Bío, Concepción, Chile, email: rfiguero@ubiobio.cl

Abstract

This paper presents the first results of a field study on thermal comfort in school buildings that is being carried out in Chile, with the aim of determining comfort temperature of students in state-owned primary schools. The paper presents the results of four schools located in Santiago, a city with low temperatures in winter and high temperatures in summer, which are typically free-running, as they have neither a heating nor a cooling system. The methodology included measurements of thermal parameters complemented with questionnaires based on the adaptive model and modified for the understanding of 9-10 years-old students. The field work was organized in two phases: winter (August) and summer (December), where in each phase the students responded the questionnaire up to three times per day in a period of three to four days. The results show that comfort temperature derived from the field work is significantly lower than comfort temperature calculated from Humphreys formula, while they also show that students from highly vulnerable schools voted lower comfort temperatures than those from less vulnerable realities.

Keywords: thermal sensation vote, primary school, children, comfort temperature

1 Introduction

The fact that thermal comfort in school classrooms has a significant impact on children's performance and health (Sensharma et al, 1998), while children spend more time in schools than in any other building except at home (Bluyssen, 2014) evidences the importance of achieving a comfortable thermal environment in school buildings.

There are very few studies on thermal comfort in schools (Mors et al 2011; Teli et al 2012, Montazami and Nicol, 2013; De Giuli et al 2014) and their results indicate that children have a different thermal perception compared with adults, suggesting that current comfort standards may not apply to school children, which emphasizes the need of more studies in this field.

In Chile, school buildings represent the most "passive" building typology, as the great majority of them has no heating or cooling system, even in climatic zones with relatively cold winters and hot summers. In addition, they usually have a poorly insulated envelope with single glazing and no solar protection, which results in important indoor temperature variations, both seasonally and daily. Currently, there are no regulations to control the quality of the thermal envelope and the only requirement for thermal comfort is an indoor temperature of 12°C, but only in the southern and colder climatic zones (south on latitude 36°) where a heating system is required. Post occupancy evaluations in school classrooms in the country (Armijo et al 2011, Trebilcock et al 2012) have found very low indoor temperatures

in winter and high temperatures in summer, stressing the need for more studies in the field, with the aim of improving thermal comfort of school children.

Therefore, this work is based on a field study carried out in Santiago, Chile, which looks at thermal comfort in free running schools in both summer and winter conditions. The adaptive model has proven to be suitable for free running buildings (Nicol et al, 2013) as it suggests that there is a relation between preferred indoor comfort temperature and outdoor temperature.

2 Methodology

The paper presents part of the findings of a larger research project that covered a field study along three cities in Chile, showing only the case studies located in the capital city of Santiago, as they represent one of the most interesting results, due to the fact that the four cases are free-running schools, with different socio-economic backgrounds. In this climatic zone, school buildings are not legally required to have a heating or cooling system, and in general there are very limited regulations that apply to thermal environment. Consequently, students only manage their thermal comfort by regulating the number of articles of clothing they wear.

2.1 The context of Santiago

Santiago is the capital city of the country, with approximately 6 million inhabitants or 37% of the national population, and an extension of more than 600 km², located at latitude 33°26'South and longitude 70°32' West. It has a Mediterranean climate, with an extended dry season in summer, with average temperatures in January varying from 13°C to 29.5°C, and a maximum temperature of 34°C. In winter, average temperatures in July vary from 3.9°C to 14.9°C, with minimum temperatures that can go below 0°C, although on very few occasions. Precipitation is concentrated in winter, with an annual rate of 325mm, and low relative humidity with an average of 70%.

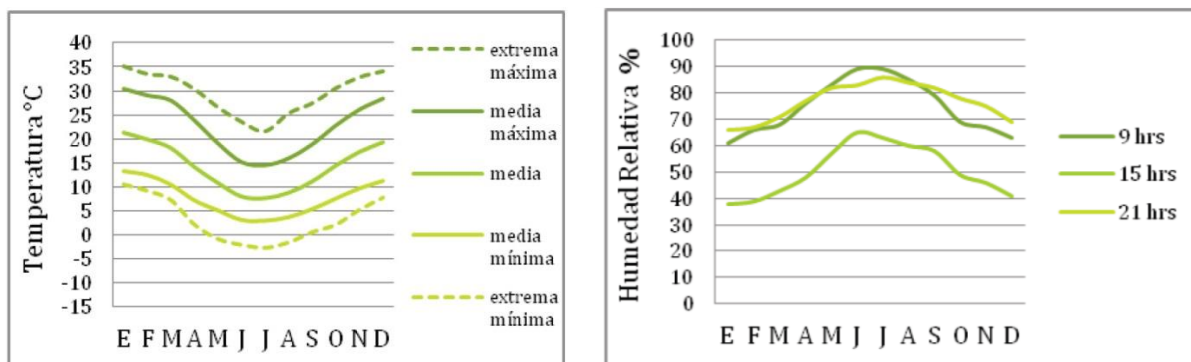

Figure 1. Climatic data of Santiago

2.2 Selection of cases

In the Santiago Metropolitan Area, there are a total of 3,817 educational establishments, which are categorized based on ownership and administration as public, subsidized, and private. The four case studies were selected from the universe of 501 state-owned schools within this group. The criteria for the selection of cases responded to the need of looking at schools from different socio-economic levels calculated by an index that represent the social vulnerability of the students (IVE SINAE index). This index reflects vulnerabilities associated to poverty, family composition, and all other factors that could lead to academic

desertion. Figure 2 shows the location of the four cases in the urban area of Santiago, as well as their IVE index, where the higher value reflects higher vulnerability of the school's students. According to this, Escuela Membrillar and Escuela República de India receive students from higher vulnerability levels than Liceo Juan Pablo Duarte and Liceo República de Siria. Photographs of each school are presented in Figure 3.



Figure 2. Location of case studies and their Index of Vulnerability

The unit of analysis for each school was one 4th year elementary class, with students varying in age from 9 to 10 years old, which was chosen for giving a good balance between a minimum age for properly understanding the questionnaire and a longer permanence in the classroom than older children. The number of students in each classroom varied from 35 to 40, but the number of responses was lower due to school attendance factors.



Membrillar School



República de India School



República de Siria School



Juan Pablo Duarte School

Figure 3: images of the four case studies

Figure 3 shows images of all four cases, where it is clear that the schools have different architectural characteristics. In terms of materiality, India, Siria and Juan Pablo Duarte schools have a heavyweight structure with high thermal mass, typically brick and concrete; while Membrillar has a lightweight structure of steel and timber. The thermal envelope is poor in all cases, with single glazing and no wall insulation. All four classrooms analysed have the main glazed façade facing eastwards, but JP Duarte school has an additional glazed area facing north, as it is located at the corner of the building. They are all accessed by an external corridor located at the west of each classroom.

2.3 Design of the questionnaire

The difficulties associated to the development of questionnaires for students have been discussed by some authors (Teli et al, 2012, Mors et al 2011). Therefore, the questionnaires for this project were developed according to Teli et al. (2012), using graphic information and colours that could be more easily understood by children. The questions included thermal sensation, thermal preference, thermal acceptability, clothing and activity. The clothing was simplified to include typical layers that students could wear over their uniform (usually a jumper and/or a parka), in the same way that the activity was simplified to include typical students' activities (sitting during the class, running during the break, etc).







The questions for thermal sensation vote and thermal preference vote did not include numbers in order to avoid confusing the children, but they did include colours and images accompanying the concepts, which ranged over the seven points scale; using terms in Spanish that are familiar to the children (Figure 4).

LUNES 8:30

1. ¿Cómo SIENTES la temperatura de la sala en este momento?

Muy fría	Fría	Un poco fría	Agradable	Un poco calurosa	Calurosa	Muy calurosa
<input type="checkbox"/>	<input type="checkbox"/>	<input type="checkbox"/>	<input type="checkbox"/>	<input type="checkbox"/>	<input type="checkbox"/>	<input type="checkbox"/>

2. Haz un tick ✓ en la frase que te parece más apropiada:

Me gustaría que la sala estuviese mucho más fría	<input type="checkbox"/>	
Me gustaría que la sala estuviese más fría	<input type="checkbox"/>	
Me gustaría que la sala estuviese un poco más fría	<input type="checkbox"/>	
Me gustaría que la sala estuviese igual	<input type="checkbox"/>	
Me gustaría que la sala estuviese un poco más calurosa	<input type="checkbox"/>	
Me gustaría que la sala estuviese más calurosa	<input type="checkbox"/>	
Me gustaría que la sala estuviese mucho más calurosa	<input type="checkbox"/>	

3. En este momento ¿Sientes que la temperatura de la sala es confortable?

Sí No

Figure 4: the first part of the questionnaire (own elaboration based on Teli et al, 2012)

Each questionnaire was designed to fit in a single colourful page, in order to be simple and attractive for the students, while all 12 questionnaires were put together in a booklet with a front page that registered personal data and the location of the student in the classroom. In this way, each student holds his/her own booklet of questionnaires that had to be responded up to three times per day (8:30 – 11:30 and 15:00hrs) during the period of study.

3 Field work

The field work was carried out in two phases: winter (August) and summer (December). In each phase, the students responded to the questionnaire up to 3 times per day during a period of 3 to 4 days, for a total of 146 answered questionnaires in winter and 127 in summer. The amount of responses was higher in winter than in summer, with a total of 1389 responses in winter and 774 responses in summer for all the cases, due to higher absenteeism during the summer period, as it was the week previous to summer holidays. The questionnaire was administered by the class teacher, who was trained by the researchers.

The measurements of thermal parameters covered a period of six days, as they started on the previous weekend. They included typical thermal data: dry bulb temperature (°C), globe temperature (°C), relative humidity (%) and air velocity (m/s). The instruments were located at the back/centre of the classroom, at 1.1m high, registering thermal data for one week in winter and one week in summer. It was not possible to locate the instrument at the centre of the classroom due to visibility and security problems, as they were fixed in that position for the whole measurement period. Figure 5 shows the location of the instrument in the classroom.



Figure 5. The instruments in two different case studies: Membrillar School (left) and Siria School (right)

The responses were firstly analysed in terms of their consistency, eliminating from the study all those responses that were inconsistent, such as giving a thermal sensation vote of -1 while stating that they prefer the classroom to be cooler.

4 Measurements

The measurements are presented in Figure 6 and Figure 7, which covers dry bulb temperature and external temperature for each case study during the winter period and during the summer period. External temperature was obtained from Quinta Normal meteorological station, located close to the city centre and near the schools.

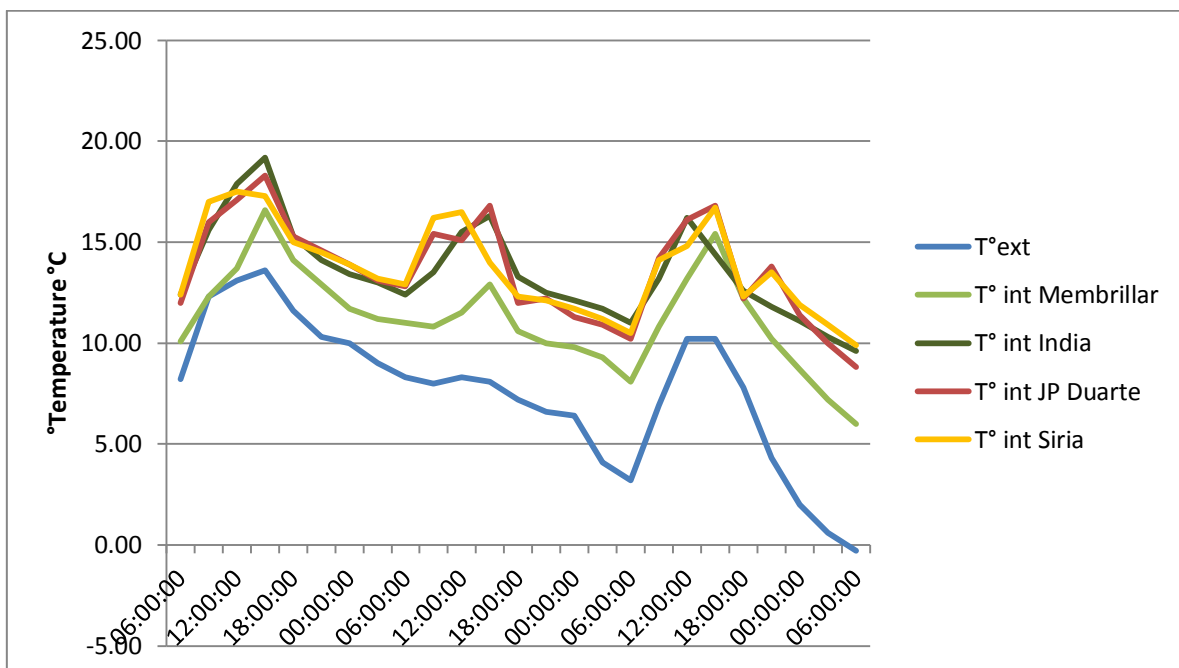

Figure 6. Internal temperature in each classroom – winter period

The results show that in winter internal temperatures are generally low, varying between 13°C and 17°C during the occupancy period for India, JP Duarte and Siria School, while temperatures in Membrillar School were 2°C lower than the rest of the cases. These low values are the result of free running schools that lack of an appropriate thermal envelope, or other appropriate design strategy that could help to passively heat the building up in winter.

In addition, Membrillar shows the worst building quality, with a very poorly insulated and leaky envelope.

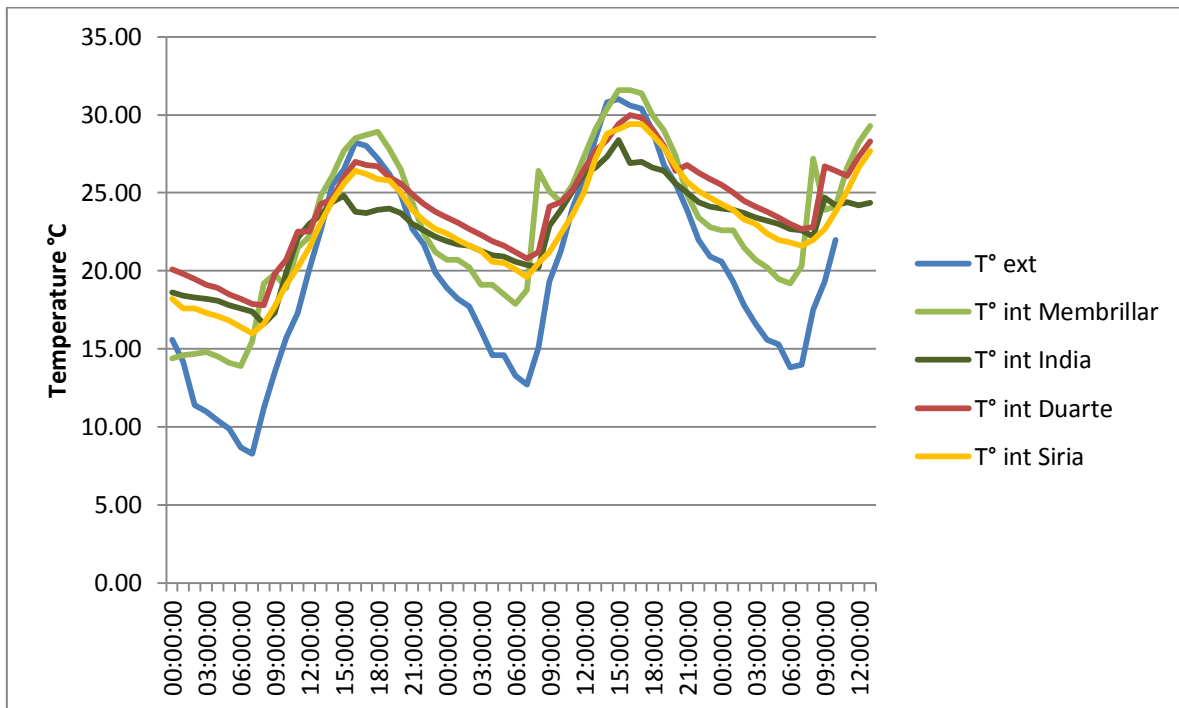

Figure 7. Internal temperature in each classroom – summer period

Similarly, indoor temperatures in summer are high, with maximum temperatures reaching 30°C during the occupancy period. Again, Membrillar School registered the poorest performance, due to its inadequate thermal envelope and lightweight structure that allows internal temperature to fluctuate according to the external temperature, while in the other three cases it is possible to observe the effect of thermal mass.

5 Thermal sensation vote

The results of the survey are presented in Figure 8, which shows the correlations between the thermal sensation vote and dry bulb temperature. The regression lines are shown in the graphs, giving the comfort temperature for each case for both winter and summer. The graphs are based on 201(w) and 214(s) votes for Membrillar; 388(w) and 290(s) votes for India; 402(w) and 162(s) votes for JP Duarte; and 398(w) and 109(s) votes for Siria.

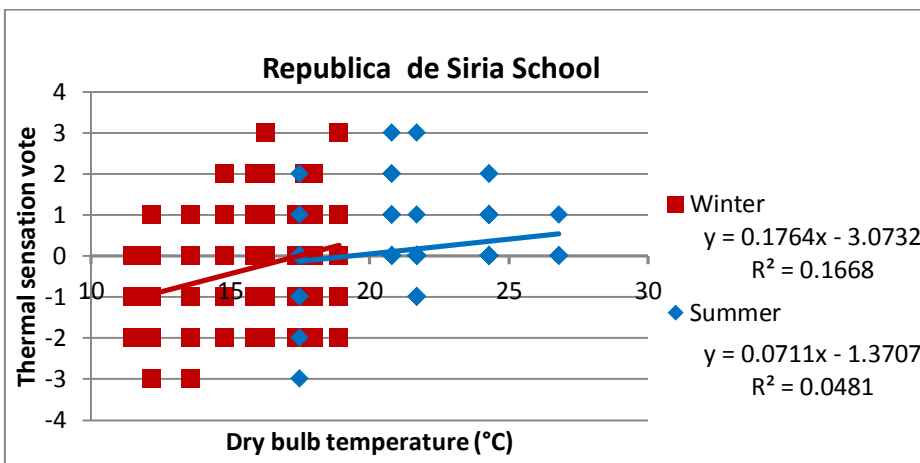
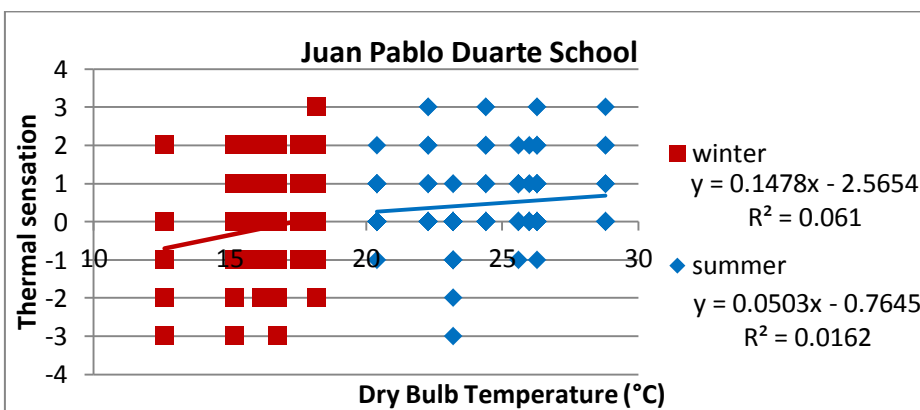
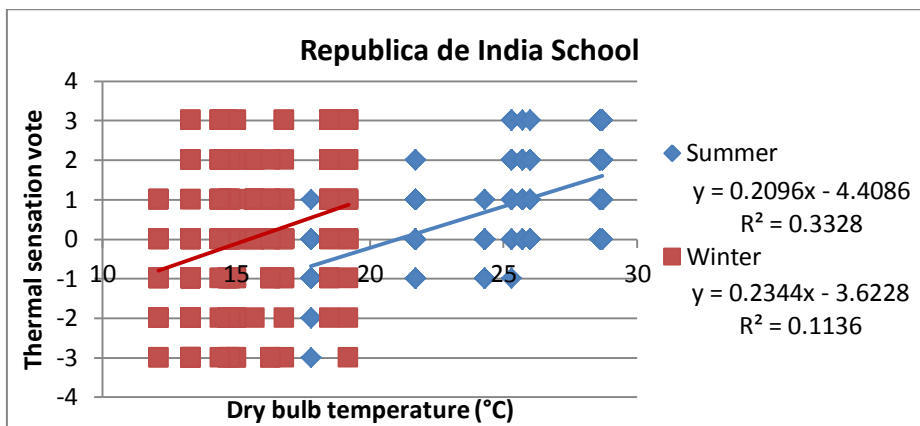
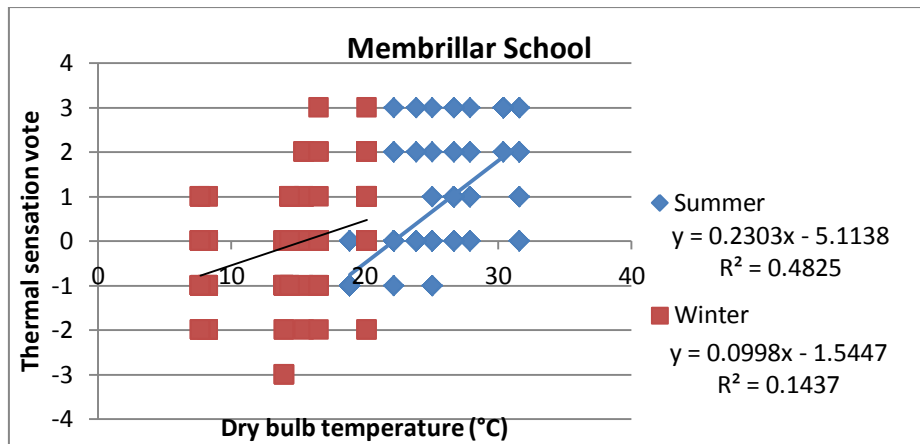

Figure 8: thermal sensation vote for each case study

Table 1: Neutral temperature from field study

	Neutral temperature winter (°C)	Neutral temperature summer (°C)
Membrillar School	15.5	22.2
Republica India School	15.5	21.0
JP Duarte School	17.4	-
Republica Siria School	17.4	-
All cases	16.7	21.1

Table 1 shows the neutral temperature for each case study, where it is possible to note that the two schools with highly vulnerable students (Membrillar and Republica de India) have significantly lower comfort temperature in winter than those with lower vulnerable students (Juan Pablo Duarte and Republica de Siria). In summer, the responses for Juan Pablo Duarte and Republica de Siria School presented a very low correlation, so only the comfort temperatures for the other two schools are presented in the table.

The results of the winter survey considering 1389 votes are shown in Figure 9, where the regression line gives a comfort temperature of 16.7°C; while the results of the summer survey considering 774 votes are shown in Figure 10, giving a comfort temperature of 21.1°C.

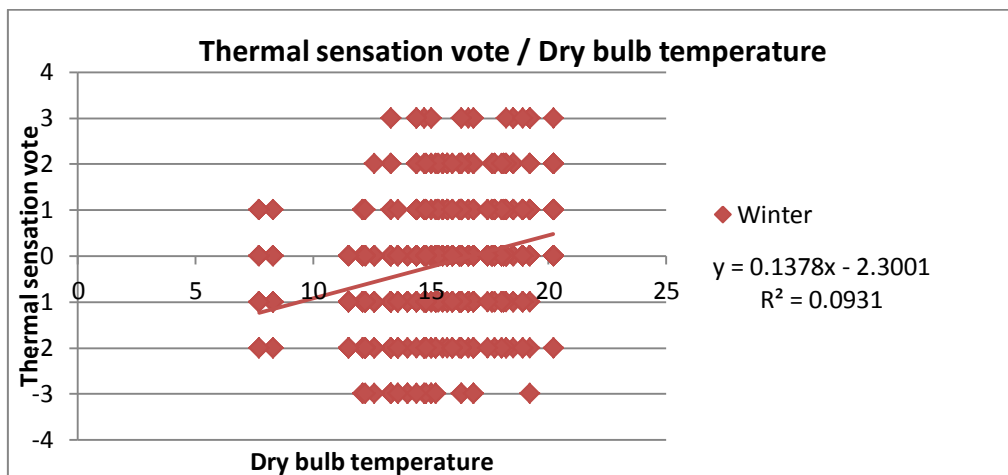

Figure 9: thermal sensation vote – winter period

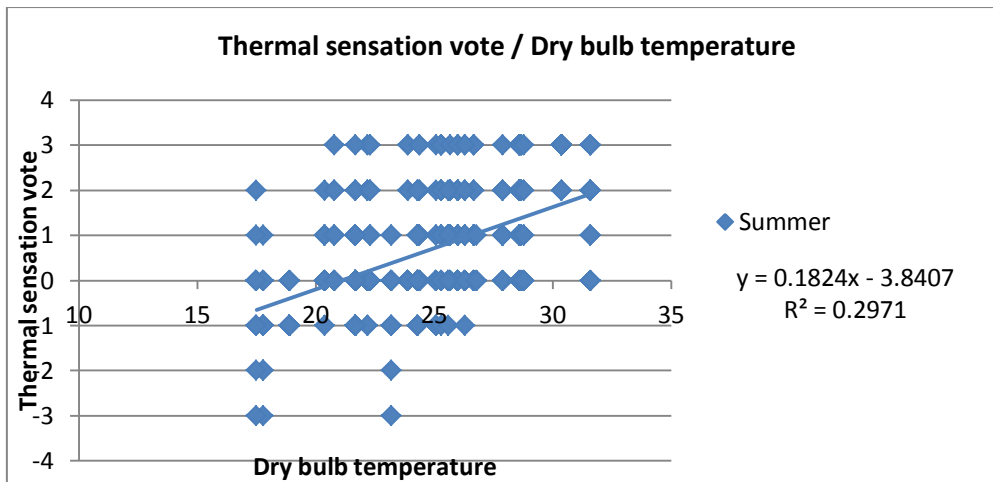

Figure 10: thermal sensation vote – summer period

Table 2 shows the results obtained from using the Humphreys formula (Humphreys et al, 2010) to calculate comfort temperature based on monthly mean outdoor temperature obtained from meteorological data, for the months when the survey took place. The results show that comfort temperature from the field work is considerably lower than the one calculated from Humphreys formula, for both winter and summer.

Table 2: Comfort temperature from Humphreys formula

	Comfort temperature from Humphreys formula (°C)
July	18.8
August	19.5
November	23.2
December	24.5

6 Conclusions

The conclusions of the first analysis of data obtained by this field study show that the comfort temperature derived from the thermal sensation vote of primary school students is significantly lower (3°C to 4°C) than those obtained from Humphreys adaptive comfort formula for free running buildings in Santiago. These results could be partly explained by the higher metabolic rate of children.

In addition, the results suggest that it might be a relation between the socio-economic vulnerability of the students in each school and comfort temperature in winter, as those students coming from highly vulnerable schools voted lower comfort temperatures than those coming from less vulnerable realities. These results might relate to the very low temperatures registered inside the classrooms, as well as fuel poverty at the children's homes, which motivate them to adapt to very low indoor temperatures in winter. Although these results are based on very few cases, they show a tendency that could be explored further with a larger sample.

7 Acknowledgements

This paper is part of the research project Fondecyt N° 1130596 “Methodology for the dynamic analysis of thermal comfort during the design process of school buildings” funded by the Chilean National Commission for Research in Science and Technology. The authors would also like to thank the teachers and children that were involved in the study, the Ministry of Education and Mrs Gaudy Bravo for their significant contribution.

References

- Armijo, G., Whitman C., Casals, R., 2011, Post-Occupancy Evaluation of State Schools in 5 Climatic Zones of Chile. *Gazi University Journal of Science*, 24(2), pp 365-374.
- Bluyssen, P., 2014, *The healthy indoor environment: how to assess occupants' wellbeing in buildings*. London, Routledge.
- De Giuli, V., et al., 2014, Measured and perceived environmental comfort: Field monitoring in an Italian school, *Applied Ergonomics* (in press).
- Humphreys, M., Rijal, H., Nicol F., 2010, Examining and developing the adaptive relation between climate and thermal comfort indoors. *Proceedings of the Conference Adapting to Change: new thinking on comfort, Cumberland Lodge, Windsor, UK*, 9-11 April 2010. London: Network for Comfort and Energy Use in Buildings. Available at: <http://nceub.org.uk>
- Montazami, A., Nicol, F., 2013, Overheating in schools: comparing existing and new guidelines, *Building Research and Information*, 41(3), pp 317-329.
- Mors, S., Hensen, J., Loomans, M., Boerstra, A., 2011, Adaptive thermal comfort in primary school classrooms: Creating and validating PMV-based comfort charts, *Energy and Buildings*, Vol 46, pp 2454-2461.
- Nicol, F., Humphreys, M., Roaf, S., 2013, *Adaptive thermal comfort: principles and practice*, London, Routledge.
- Sensharma, N., Woods, J., A.K. Goodwin, A., 1998, Relationship between the indoor environment and productivity: a literature review, *ASHRAE Transactions*, 1A, p. 104.
- Teli, D., Jentsch, M., James, P., 2012, Naturally ventilated classrooms: An assessment of existing comfort models for predicting the thermal sensation and preference of primary school children, *Energy and Buildings*, Vol 53, pp 166-182.
- Teli D., James, P., Jentsch, M., 2013, Thermal comfort in naturally ventilated primary school classrooms, *Building Research & Information*, 41(3), pp 301-316.
- Trebilcock, M., Bobadilla, A., Piderit, M., Guzmán, F., Figueroa, R., Muñoz, C., Sánchez, R., Aguilera, C., Hernández, J., 2012, Environmental Performance of Schools in Areas of Cultural Sensitivity, *Proceedings of PLEA 2012 (Passive Low Energy Architecture) Conference*, Lima, Nov 2012.

WINDSOR CONFERENCE 2014

COUNTING THE COST OF COMFORT

WORKSHOP 1

Comfort, user behaviour and energy efficiency

Invited Chairs: Jens Pfafferott and Atze Boerstra

WINDSOR CONFERENCE 2014

COUNTING THE COST OF COMFORT

THE WORKSHOP PROGRAMME

WORKSHOP 1: Comfort, User Behaviour and Energy Efficiency

Invited Chairs: Jens Pfafferot and Atze Boestra

11th April 2014: 16.30 – 18.30 - Flitcroft Room (2 Hours)

It is widely accepted that the adaptive approach to thermal comfort may be applied to passively cooled buildings and the static approach to air-conditioned buildings. Though the standards (e.g. EN 15251 or ASHRAE 55) give precise definition that the adaptive approach should only applied to buildings without any kind of mechanical cooling, there is an on-going discussion on the application of the adaptive or a hybrid approach to mixed-mode buildings or low-energy buildings with limited cooling capacity (e.g. mechanical night ventilation or thermo-active building systems), respectively. In recent years, more and more buildings have been built in or retrofitted towards low-energy or even zero-energy standard. Consequently, most new and retrofit office buildings use low-energy cooling with limited cooling capacities. Hence, owners, planners and architects ask for good building practice and a legislative binding procedure for the classification of thermal comfort in low-energy buildings. Interactive discussion will explore aspects of thermal comfort and user behaviour especially for buildings with low-energy cooling concepts. US perspective.

Proceedings of 8th Windsor Conference: *Counting the cost of comfort in a changing world* Cumberland Lodge, Windsor, UK, 10-13 April 2014. London: Network for Comfort and Energy Use in Buildings, <http://nceub.org.uk>

Designing resilient housing for co-evolutionary adaptivity

Fionn Stevenson¹, Magda Baborska-Narozny¹

¹ School of Architecture, University of Sheffield, UK
f.stevenson@sheffield.ac.uk

Abstract

Buildings and communities need to be more resilient in the face of increasing weather extremes due to climate change. Current building models lack adequate definition to address this new challenge. This paper defines resilient design in terms of four ecosystemic factors: robustness, redundancy, feedback and co-evolutionary adaptivity. It builds upon previous work on usability and extends this to include resilient performance in relation to three new UK case studies covering retrofit and new build housing. In each case usability studies are evaluated in terms of resilient design. Key areas of concern identified in the studies relate to the vulnerability of centralised ventilation systems and the lack of interactive adaptability in relation to the construction systems adopted. Lessons learnt and recommendations are highlighted for design guidance and policy consideration, including a greater focus on delivering low carbon homes that are able to be more resilient over time through co-evolutionary adaptivity.

Keywords: low-carbon housing, resilience, user, adaptivity

Introduction

The latest contribution to the Intergovernmental Panel on Climate Change's fifth assessment report (IPCC, 2014) confirms the virtual certainty of more frequent hot and fewer cold temperature extremes over most land areas, increased heat waves, occasional cold winter extremes, and significantly increased precipitation. These increasing extremes are already generating significant increases in flooding, storms, wind speeds as well as new temperature records which demand an urgent response from building designers, product manufacturers and occupants. This paper sets out a number of key interrelated issues concerning the performance of environmental controls in UK housing, which need to be tackled in terms of climate change adaptation. It then sets out a definition for resilient design for buildings in terms of four systemic factors: *robustness, redundancy, feedback and co-evolutionary adaptivity*. Three new UK case studies covering retrofit and new build housing are examined to see how well key environmental controls in the home perform in each case in relation to these factors. Usability studies are evaluated in terms of resilient design principles, in order to extract key lessons for improving environmental control in housing over time. The paper concludes with a wider discussion about the direction of research and policy in relation to the issues raised.

The environmental 'control' problem

Future overheating issues in the existing UK housing stock as a result of climate change have been widely discussed and modelled at the level of potential building and neighbourhood interventions which take account of socio-technical and economic

challenges (Williams et al, 2013) (Gupta and Gregg, 2012, 2013) (Porritt et al, 2012). More worryingly, *current* overheating in new PassivHaus homes in Belgium has already been highlighted in detailed post-occupancy studies, with summer indoor temperature regarded as too high by up to 50% of occupants, particularly in living rooms and kitchens (Mlecnik, 2013).

There is a clear need for more detailed understanding of how well occupants are currently able to mitigate overheating at the level of environmental control available to them in order to improve predictive modelling as well as closing the actual performance gap (Stevenson and Leaman, 2010). Yet, standard building simulation software and regulations do not take account of climate change, even though data is available (e.g. Prometheus using UKCP09 modelling). While there is some guidance on designing buildings so that they can adapt to climate change (Gething and Puckett, 2013) this tends to be at the level of imposed product solutions (Porritt et al, 2012) rather than designing buildings so that people and buildings can adapt to and learn from each other over time (Brown and Cole, 2009). Equally, the discourse about how 'smart' buildings should respond to climate and occupant behaviour tends to be framed in terms of improving an increasing use of technology (Mlecnik 2013) rather than de-mechanisation (Ford 2012) which would potentially increase the resilience of building systems.

There is growing recognition of the need to deal with probabilities of changing conditions related to our weather rather than assuming any certainty (IPCC, 2014). The optimisation of building solutions provided by current building simulation modelling and building standards is therefore no longer valid in itself, because it does not take into account means of dealing with failure and uncertainty related to environmental control. Optimisation in itself does not provide the breadth of response that is required either in terms of unpredictable heating or cooling, or indeed in terms of 'unthinkable' events which are outside current frames of reference in relation to building design. More worryingly, there is persistent climate change denial both at an institutional and personal level in terms of how people choose to act which permeates through human society, given that two thirds of the UK population disavow climate change (Royal Society of Arts, 2013). This means that people accept the reality of climate change but choose to minimise its importance in their lives. This in turn affects the research and design community given that the environment is still framed as something that can be 'controlled' with appropriate measures, rather than a recognition that we face chaotic situations in the future.

Resilient interactive adaptivity

One response to all of the above is to design buildings and communities to be more resilient – defined here as being able to '*resist, absorb, accommodate to, and recover from unpredictable climate change effects in a timely and efficient manner, while preserving and restoring essential basic structures and functions*' (UNISDR, 2009). There is, however, a wide discourse on resilience with many different definitions of the term (Hassler and Kohler, 2014a). The principles of fundamental resilience used here, drawn from Biggs et al (2012), are based on making environmental services resilient in terms of a 'socio-ecological system' (SES) which takes account of how human communities interact with their environment (fig.1): (P1) maintain diversity and redundancy, (P2) manage connectivity, (P3) manage slow variables and feedbacks, (P4) foster an understanding of SES as complex adaptive systems (CAS), (P5) encourage learning and experimentation, (P6) broaden participation, and (P7) promote polycentric governance systems.

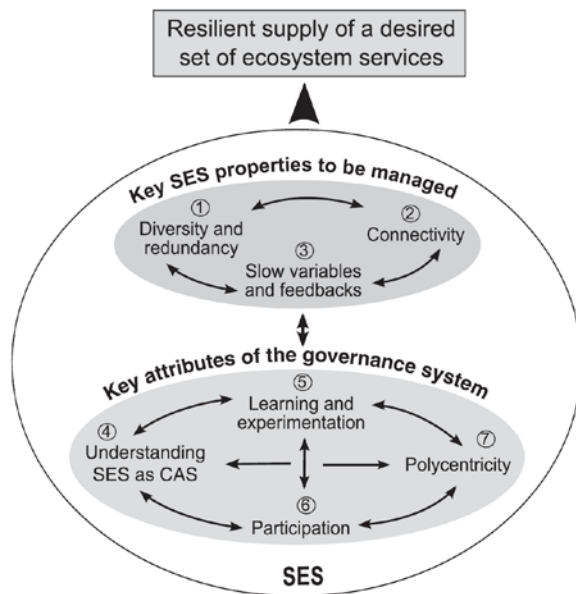

Figure 1. Resilience Properties and Dynamics, taken from Biggs et al, 2012.

Drawing on these principles for SES, this paper reframes resilient building design in terms of four ecosystemic factors which are directly related to the usability of a building: *robustness* – the degree to which a building can withstand the various shocks of climate change (P1), *diversity and redundancy* – the number of different ways in which a building can respond to these shocks, beyond the optimal solution (P1), *feedback* – the ability for a building to provide users with a direct understanding about what is happening (P2, P3) and *co-evolutionary adaptivity* – the ability for buildings and users to mutually develop their ability to respond to changes through time including climate change (P4, P5). P6 and P7, relating to governance issues, are beyond the scope of this paper but need further work to ensure buildings are properly managed.

Existing work on usability (Stevenson et al 2013) is theoretically extended here to include these four resilience factors. In terms of robustness, this includes the ability to maintain and repair any fabric, system or equipment designed to support buildings in delivering safe and healthy environments. The more active technological systems are provided in housing, the more maintenance and care for them is required. Appropriate maintenance also requires awareness of what is required (feedback). The concept of a resilient building should not only cover the features built into a building but also *the quality of interaction a building offers to its users, their understanding of what is offered and expected of them, and their ability to turn the understanding into action as circumstances change*. This has previously been termed ‘interactive adaptivity’ (Brown and Cole, 2009). Interactive adaptivity, however, has to take on an evolutionary dimension to ensure resilience over a longer period of time, and is thus defined as ‘co-evolutionary adaptivity’ in this paper. As Briggs et al (2013 p.427) point out:

Understanding the relationships between diversity, redundancy, and resilience requires the development of practical methods for measuring diversity and redundancy and for identifying critical processes or keystone entities in different SES. Identifying and managing these vulnerable points may be the most effective way to maintain the resilience of ES (ecosystem services).

It is the last point that is of crucial relevance to the co-evolutionary adaptivity of buildings - the vulnerabilities in the design of environmental control interfaces and their interaction within a building. If these vulnerabilities can be identified, then suitable diversity and redundancy can be built into the building systems design to ensure that if there is a system failure, occupants have an alternative sub-optimal means of achieving the same effect in terms of environmental control. The use of case study methodology is an excellent way to identify such vulnerabilities in current building design.

Case Studies

Three new case studies (fig.2) have been selected from a spectrum of recent housing developments which represent different building typologies and demographic factors but within a similar climate and culture in Northern England. This allows for a greater degree of comparability (Table 1) (Flyvbjerg, 2006).



Figure 2: LILAC (above) and Saxton west (middle left) and east view (middle right). Photo MBN, Lancaster (below) Photo FS.

The studies have also been chosen to reflect very different housing energy standards operating in the UK. The four resilient design factors are examined in relation to the comparative performance of the housing developments built to each of these standards. Data for the case studies was gathered from March 2012- January 2014.

Case study	Lancaster Cohousing	LILAC Cohousing	Saxton Gardens
Completion	2012	2013	2011
Location	Semi-Rural	Urban	Urban
Size + units	Medium, 35 units Owned	Medium, 20 units Mutually owned	Large, 200 units Owned/rented
House types	New build terrace houses/ apartments in blocks	New build terrace houses/ apartments in blocks	Refurbishment 1950's apartment block
Fabric materials	Masonry and timber frame, clay roof tiles, timber floor	Straw/timber panel system, flat roof, concrete floor	Concrete structure and slabs, SIPs panels, flat roof
Energy, heating and ventilation features	PV panels, MVHR, communal biomass/solar thermal, radiators	PV panels, MVHR, natural gas boilers in each home, radiators	MEV, thermostatic programmed electric heating panels
Energy standards	Passivhaus certified, 'Zero Carbon' Code for Sustainable Homes level 6 (UK)	Code for Sustainable Homes Level 4	2006 Building Regulations for retrofit in UK Eco Homes Very Good

Table 1: Case study characteristics

Methods

In each of the case studies, an evaluative usability sub-study, as developed by Stevenson et al (2013), has been cross-related to commissioning checks on the heating and ventilation systems, occupant guidance, and construction audits, which were carried out as part of wider building performance evaluation studies^{1,2}. In the Lancaster case study, supplementary reference is also made to six semi-structured 45 minute interviews as well as a BUS questionnaire on control and comfort. The initial usability study carried out at Lancaster was subsequently developed into an interview-based multiple choice questionnaire for wider use at the LILAC and Saxton Gardens case studies with comment boxes to elicit quantitative and qualitative information. Results for the usability surveys were obtained from one typical house in Lancaster, together with 7 houses and 12 apartments at LILAC and 20 apartments at Saxton Gardens. User 'touchpoints' are defined as anything in the home that the user physically touches in order to provide environmental and comfort control. Although the 'touchpoints' are normally divided into 7 categories, only the heating and ventilation user controls (considered in the widest sense) are considered here in relation to achieving thermal comfort, as these are widely recognised as the key challenge in UK housing at present related to climate change and overheating issues. These are examined in terms of the degree of compliance with the four resilient design factors identified above. The findings from these are set out next.

Heating feedback and user understanding

Heating controls and feedback across all three case studies proved problematic in terms of user understanding. Just under half of occupants in LILAC did not know what the boiler controls were for, although the heating programmers were generally understood. However one LILAC resident commented: '*I don't understand the relationship between the boiler, thermostat and the heating controls*'- an issue that was shared among a number of occupants. In Saxton Gardens, less than half the occupants knew what the programmer on the electric heating panels was for in relation to time settings (fig.3), although nearly all understood how to change the

temperature setting on the panel heater, as demonstrated by one occupant's observation: *'Electric panel heater control isn't very clear to use. I just use the on/off switch. Electric panel temp control – we always have it on the top setting'*



Figure 3: Saxton panel heater controls - timer (left), power switch and temperature (right)

A significant number of occupants in both LILAC and Saxton Gardens also did not know how to operate the Immersion Hot Water Cylinder with a typical comment from one resident in LILAC summing up the situation:

I don't understand how the tanks work or the relationship between the large and small tank. I don't know how to interpret the temp reading on the small tank (thermal) or understand when I would use immersion heater on this system.

In Lancaster, the main problem was the heating programmer, which was poorly sited in some cases, and the thermostat, which had an unnecessarily complex 'Eco-button'. An issue that compounded the situation at Lancaster was the high degree of thermal mass which resulted in a relatively slow thermal response. This took time for occupants to adjust to and understand. The adjustment was one way, with no co-evolutionary adaptivity present insofar as these building systems did not 'learn' from the occupants and could not be adapted by the occupants to suit their needs.

Ventilation feedback and user understanding

The understanding of ventilation systems presented much more of a contrast across the case studies. In Lancaster, the system was well installed with a good level control and careful occupant induction – something that many PassivHaus developments have achieved. The mechanical ventilation heat recovery (MVHR) unit control panel was found easy to use and a change in air movement, plus a slight increase in the sound of the MVHR system gave a good indication of response (feedback). By contrast in LILAC only two out of 18 occupants understood what the MVHR unit control panel was for or how it worked. Just over half understood what the boost was for, while just over two thirds understood the cooker hood extract. This was despite an induction session (although some occupants missed this) and a home user guide that had been extensively revised following consultation with the researchers. Even so, the guidance on the ventilation system was not particularly easy to understand.

The Mechanical Extract Ventilation (MEV) system in Saxton Gardens should be as simple to control as the MVHR systems in the other two case studies. However, occupants failed to understand the use of the complex humidistat control introduced to meet Ecohomes 'Very Good' certificate. The control located high on bathroom wall allowed them to alter the relative humidity limit from 40-90%. This backfired, because occupants had no idea what the figures meant and in the course of a trial and

error 'learning' process some occupants turned the dial to maximum and left it at this setting, losing interest in a control that did not respond to any actions taken. The lack of response was also partially due a result of occupants switching off the bathroom MEV fan altogether, allowing these areas to remain unnecessarily humid. This did, however help to reduce the noise level of the MEV system, which was a persistent complaint of many occupants. However, most occupants simply switched the MEV system off altogether. This was despite good written guidance on how to use the system being provided to initial occupants.

Resilient heating and ventilation

Heating systems

A requisite for co-evolutionary adaptivity is occupant understanding of the heating systems installed. In these case studies, it is difficult to see how this can occur, given the poor feedback provided to the occupant in relation to some aspects of these systems. In terms of robustness, redundancy and critical points of vulnerability, the Lancaster heating system currently relies on a communal biomass boiler system with solar thermal pre-heating. While this is very robust in terms of not relying on a natural gas central energy supply grid but having it there as a backup supply if needed, the heating systems in the homes cannot be upgraded with further radiators unless the communal boilers are already oversized to allow for this. However, additional electrical power is also generated through a robust communal photovoltaic (total installed capacity of 1.8 kW per dwelling) and hydro system (160 kW total for the development) which could in future help to provide alternative electrical heating in emergencies. By contrast, LILAC relies on a traditional natural gas supply directly from the grid for individual boilers in each home. This has a critical vulnerability in terms of the security of international gas supplies. Nevertheless, it also has a photovoltaic system (total installed capacity of 1.25 kW per dwelling) that could supplement a small amount of heating in emergency. Saxton relies completely on the national grid to supply electricity to the room heating panels in each home, and while electricity potentially offers the greatest diversity for heating systems, there is a critical vulnerability here in terms of predicted power shortages and failures for the UK in the future.

Ventilation systems

It would appear that MVHR and MEV systems can offer a good degree of systemic feedback to occupants, provided both good guidance and induction processes are in place, but that this can still be compromised due to other issues such as noise from imbalanced ventilation systems or occupants failing to remember what the controls are for. Resilient co-evolutionary adaptivity is difficult with mechanical ventilation systems because the occupant has no easy means of physically altering the installed system should circumstances change (e.g power cuts) – indeed they are explicitly asked not to interfere with the air inlets and outlets – although Lancaster occupants have learnt relatively quickly how to adapt to the system itself.

A key concern with mechanical ventilation systems lies in their degree of robustness and critical points of vulnerability. At the moment these systems do not necessarily switch on automatically after power outages with one Lancaster resident reporting:

The MVHR sort of tripped out after a power outage and stayed tripped out which is a bit of a worry because if you were away on holiday or something that happened, then you would be left without any ventilation in the house and you wouldn't know about it. I don't see why that unit should do that.

This lack of robustness is compounded when other information systems also rely on electrical power as one Lancaster resident pointed out:

If you get a toaster it comes with an instruction booklet but the house user guide is on the internet...You can't access something with no internet connection and I think that is a failure.

Windows and Doors

LILAC and Lancaster window and external door openings are roughly 50% of the overall glazed area, and can be opened wide while in Saxton about one third of the window area can be opened, but the opening is restricted to less than 10cm except for the sliding balcony door in some apartments (fig.4). The provision of robust and diverse window openings for night purging ventilation is critical in relation to climate change predictions for warmer summers in the UK – arguable a high degree of redundancy is required in window openings to cope with future conditions.



Figure 4: Windows in Saxton (top), LILAC (bottom left and middle), Lancaster (bottom right)

None of the three case studies have solar shading for the windows and external doors per se, which would help to avoid overheating both now and in the future due to climate change, although the Lancaster and LILAC developments have nominal shading offered by south facing balconies. Saxton has a few internal balconies also facing east and west which offer more solid shading but most windows are exposed to solar gain. Shading provision is increasingly important as temperatures rise as it is one of the most effective ways of mitigating overheating (Gupta and Gregg, 2013). In terms of feedback and co-evolutionary adaptivity, these windows are a very robust mechanism that can be readily adapted and easily understood by the user, providing

excellent sensory feedback. They require no electrical power to operate them, unlike mechanical ventilation systems.

Construction fabric

The construction of each development is remarkably different and this greatly affects the overall resilience of the heating and ventilation systems. LILAC utilises the innovative Modcell© timber panel system infilled with straw for its walls and roof, achieving airtightness levels ranging from $1.54 \text{ m}^3/\text{h}^{-1}/\text{m}^{-2}$ @ 50Pa to $4.30 \text{ m}^3/\text{h}^{-1}/\text{m}^{-2}$ @ 50Pa. Lancaster has a hybrid construction of double skin concrete block walls with 300mm mineral fibre insulation in between, and a timber frame with mineral fibre insulation on the south side with exceptional airtightness levels of $<0.6 \text{ m}^3.\text{h}^{-1}.\text{m}^{-2}$ @ 50Pa. By contrast Saxton is only designed to achieve $<7 \text{ m}^3/\text{h}^{-1}/\text{m}^{-2}$ @ 50Pa as per the 2006 Building Regulations for England and Wales. The original 1950's concrete stairs and structural system was retained in Saxton Gardens with columns and floors extended and clad with new lightweight SIP panel envelope punctured by extensive glazing.

Despite the majority of occupants completely switching off the MEV, the relatively poor airtightness of Saxton actually provided the robustness necessary for adequate ventilation even when all the windows are closed and the MEV is cut off. Lancaster has thermal mass which can help to even out excessive temperatures whereas the thermal mass in Saxton is largely isolated, leaving it more vulnerable to temperature swings, should the MEV fail, given the relatively limited ventilation openings. What this shows is that homes which have mechanical heating and ventilation systems need to have a degree of *overall* robustness and redundancy which can cope with unpredicted failures. This is discussed more widely in the next section.

Lessons for Co-evolutionary Adaptivity

1. Future proof our memories

The need to ensure that buildings are future-proofed in terms of sequential upgrades that respond to overheating has been picked up in the non-domestic sector where there is a need for natural ventilation control strategies to be '*remembered and retained*' within subsequent work (Short et al, 2012). Through the promotion of optimised standards and related packages such as PassivHaus, as applied in the Lancaster case study, we are actually witnessing a decline in the resilience of homes in terms of the ability for users to be able to ventilate naturally if mechanical ventilation systems break down. This is due to a tendency to optimise the number of window openings in relation to mechanical ventilation systems for cost purposes, with no allowance for redundancy and over-ventilation options to deal more resiliently with future unpredictable climate changes. Equally people are positively encouraged to rely on the MVHR systems rather than window use – the '*memory*' of resilient natural ventilation control strategies is thus lost both to people and the buildings they live in.

2. Create redundancy and diversity in ventilation

A recent MVHR study (NHBC 2013) revealed that occupants were suffering from overheating in the summer of 2011 in the UK due to only being able to open a patio door and no windows in the lounge at night. Understandably, occupants were reluctant to open the door due to perceived security risks. A similar reduction in openable window area was observed in the Saxton case study. Such narrowly focused efficiency necessarily introduces other fragilities into the building system (Anderies, 2014). These fragilities are usually hidden from the user by virtue of the good design of the new MVHR or MEV system and are only exposed when the system fails. In the

same monitored UK housing development less than 1 l/s was delivered through each of the supply air valves in the living rooms due to the MVHR system being almost completely blocked by dirty flyscreens (NHBC, 2013) showing a critical vulnerability of the system. The total exhaust air flow rate, however, was measured as 29 l/s suggesting that most of the make-up air was being supplied through fabric infiltration or doors and windows. As with Saxton, the housing fabric itself was able to afford the extra ventilation needed to ensure comfort, showing the overall home ventilation system offered some unplanned but essential redundancy and diversity.

3. Stress test for affordance

Introducing stress tests in housing for each good or service provided to make some predictions about how the system might react in extreme situations, could help to overcome some of the heating and ventilation issues highlighted in the case studies (Nicol and Knoepfel, 2014). A key issue here is to ensure that homes with vulnerable technologies such as mechanical ventilation systems are stress tested to ensure that they have other passive means of providing the same environmental control. Some have argued that it is difficult to incorporate such resilient design affordances for many different future climate change options if costs are to be kept within reason (Anderies, 2104) but there are examples, such as the Nottingham Solar Decathlon House (Ford et al, 2012) which demonstrate low cost resilient housing design which can cope with either warmer or cooler climates.

4. Develop passive co-evolutionary strategies

Miller et al (2012) discuss managing comfort related to warmer, subtropical conditions in an Australian context where resilient homes with passive features cope remarkably well. These conditions will increasingly apply to UK and Europe as predicted by climate change and urban heat island experts. Co-evolutionary adaptive strategies such as utilization of internal space (e.g. moving to a warmer/cooler location), using mechanical aids (e.g. ceiling fans) or operating the building fabric itself (e.g. opening and closing windows, doors, adjusting shading, adding reflectance etc) and even utilising outdoor living spaces will become increasingly important in making homes more resilient. It is vital that homes, such as those evaluated in the case studies presented, are future-proofed with a degree of redundancy to allow these features to be added or activated, given that resilience contains both a preventative and a recovery aspect.

Conclusion

This paper has evaluated the resilience of typical UK mechanical heating and ventilation systems in relation to their usability in three housing case studies, with mixed results in terms of feedback and co-evolutionary adaptivity. There are clear concerns in relation to some critical vulnerabilities of these systems which already affect occupants today and will almost certainly affect them more in the future. At the same time, a certain degree of robustness and redundancy has been revealed in the housing developments examined. It is essential that the drive for narrow efficiency does not iron this out in future housing developments or retrofitting of existing stock. Cultural capital is a critical aspect of building resilience, through ensuring that tacit knowledge and understanding built up over a long time is preserved (Hassler and Kohler, 2014b). As Hassler and Kohler point out (2014a):

resilience depends upon sentience and capabilities that must be embodied within people (and not automated systems). The design of any system must provide clear feedback on its performance to allow for learning and adjustment.

In terms of environmental control for occupants in their homes, we are seeing a memory loss in relation to highly robust controls (openable windows) which are rapidly being replaced by highly vulnerable and relatively untested controls (MEV and MVHR systems) as the ventilation system of choice in the UK, creating a path dependency that locks out significant cultural capital and reduces the existing resilience of homes. This has significant implications for policy making in the UK which is currently moving towards increasing and optimised levels of airtightness and mechanical ventilation in housing as a solution for reducing carbon emissions. It is vital that any new technology for housing is stress tested through the building regulations and equivalent performance standards for future climate change scenarios in terms of the key resilience factors identified in this paper. These stress tests need urgent and rapid development. Equally, legislation should ensure that passive co-evolutionary strategies for heating and ventilation that are already present in existing housing are recognised and not displaced by systems with increased vulnerability.

Acknowledgements

The authors gratefully acknowledge the funding provided for research informing this study by the Technology Strategy Board through its Building Performance Evaluation Programme, and the EU FP7 Marie Curie Intra European Fellowship programme, as well as the generous time given by the developers and occupants involved in these case studies.

Endnotes:

¹Technology Strategy Board Building Performance Evaluation Programme, UK: Lancaster Co-housing Development: TSB BPE Phase 1

²EU FP7 Marie Curie Intra European Fellowship programme: BuPESA project

References

- Anderies, J.M., (2014) Embedding built environments in social–ecological systems: resilience-based design principles. *Building Research & Information*. 42 (2) pp 130-142. DOI: 10.1080/09613218.2013.857455
- Biggs, R. , Schlüter, M. Biggs, D., Bohensky, E.L., BurnSilver,S., Cundill,G. Dakos,V., Daw,T.M., Evans,L.S. Kotschy,K. Leitch,A.M., Meek,C., Quinlan, A., Raudsepp-Hearne,C., D. Robards,M.D.,Schoon, M.L., Schultz,L.& West, P.C.(2012)Toward Principles for Enhancing the Resilience of Ecosystem Services. *Annual Review of Environment and Resources*, 37, pp 421-448 DOI: 10.1146/annurev-environ-051211-123836
- Brown, Z. & Cole, R.J. (2009) Influence of occupants' knowledge on comfort expectations and behaviour. *Building Research & Information*, 37 (3), pp 227-245.
- Flyvbjerg, B., (2006). Five misunderstandings about case-study research. *Qualitative Inquiry*, 12(2) ,pp 219-245.
- Ford, B., Wilson, R., Gillott, M., Ibraheem, O., Salmeron, J., & Sanchez, F. J. (2012). Passive draught evaporative cooling: performance in a prototype house. *Building Research & Information* 40 (3), pp 290–304.
- Gething, B. and Puckett,K. (2013) *Design for Climate Change*, RIBA publishing, London.
- Gupta, R.,& Gregg, M. (2012) Using UK climate change projections to adapt existing English homes for a warming climate. *Building and Environment*, 55, pp 20–42.
- Gupta. R. & Gregg. M. (2013) Preventing the overheating of English suburban homes in a warming climate. *Building Research & Information*. 41(3), pp 281-300. DOI: 10.1080/09613218.2013.772043

- Hassler, U. & Kohler, N. (2014a) Resilience in the built environment. *Building Research & Information*. 42 (2), pp 119-129. DOI: 10.1080/09613218.2014.873593
- Hassler, U. & Kohler, N. (2014b) The ideal of resilient systems and questions of continuity. *Building Research & Information*, 42 (2), pp 158-167. DOI: 10.1080/09613218.2014.858927
- IPCC (2014) *Climate Change 2013: The Physical Science Basis*, Working Group I contribution to the IPCC Fifth Assessment Report (WGI AR5), Intergovernmental Panel on Climate Change, Geneva.
- Miller, W., Buys, L. and Bell, J. (2012) Performance evaluation of eight contemporary passive solar homes in subtropical Australia. *Buildings and Environment*.56, pp 57-68.
- Mlecnik, E. (2013) *Improving passive house certification: recommendations based on end-user experiences*, Architectural Engineering and Design Management, 9 (4) pp 250-264, DOI: 10.1080/17452007.2012.738044
- NHBC (2013) *Report NF 52: Assessment of MVHR systems and air quality in zero carbon homes*, NHBC Foundation, Milton Keynes.
- Nicol, A.L. & Knoepfel, P. (2014) Resilient housing: a new resource-oriented approach, *Building Research & Information*. 42(2), pp 229-239. DOI: 10.1080/09613218.2014.862162
- Porritt, S. M., Cropper, P. C., Shao, L., & Goodier, C. I. (2012) Ranking of interventions to reduce dwelling overheating during heat waves. *Energy and Buildings*, 55, pp.16–27.
- Royal Society of Arts (2013) *A New Agenda on Climate Change: facing up to stealth denial and winding down on fossil fuels*. Royal Society of Arts, London.
- Short, C. A., Lomas, K. J., Giridharan, R. et al. (2012) Building resilience to overheating into 1960's UK hospital buildings within the constraint of the national carbon reduction target: Adaptive strategies. *Building and Environment*, 55, pp 73-95.
- Stevenson, F. & Leaman, A. (2010) Evaluating housing performance in relation to human behaviour: new challenge. *Building Research & Information*, 38(5), pp 437-441.
- Stevenson, F., Carmona-Andreu, I. & Hancock, M. (2013) *The usability of control interfaces in low-carbon housing*, Architectural Science Review. 56 (1), pp 70-82. DOI:10.1080/00038628.2012.746934
- UNISDR (2009) *Global assessment report on disaster risk reduction: Risk and poverty in a changing climate*, United Nations International Strategy for Disaster Reduction Secretariat.
- Williams, K., Gupta, R., Hopkins, D., Gregg, M., Payne, C., Joynt, J.L.R., Smith, I. & Bates-Brkljac, N. (2013) Retrofitting England's suburbs to adapt to climate change, *Building Research & Information*, 41(5), pp 517-531, DOI: 10.1080/09613218.2013.808893

Proceedings of 8th Windsor Conference: *Counting the Cost of Comfort in a changing world* Cumberland Lodge, Windsor, UK, 10-13 April 2014. London: Network for Comfort and Energy Use in Buildings, <http://nceub.org.uk>

Comfort and adaptation in mixed-mode buildings in a hot-dry climate

Anoop Honnekeri¹, Gail Brager¹, Shivraj Dhaka², Jyotirmay Mathur²

1 Center for the Built Environment, University of California Berkeley

2 Center for Energy and Environment, Malaviya National Institute of Technology Jaipur

Abstract

Mixed mode (MM) buildings open up a new arena for energy efficient design. Zoned MM buildings are the most common, particularly in the developing world where only some areas in a building are air-conditioned (AC) based on programmatic requirements while the rest of it is naturally ventilated (NV). Occupants in the NV zone frequently visit the AC zone and are well aware of the conditions there. The unanswered question in such a MM building is whether occupants in the NV zone have similar adaptive behaviour and thermal comfort opinions as those in purely NV buildings or are they possibly influenced by higher expectations created from the AC zone visits.

A transverse (cross-sectional) study was conducted between April 2011 to July 2013 in the hot and dry climate of Jaipur, India, including 2869 total survey responses, out of which 604 were from zoned type MM buildings. Mixed mode observations were available only during summer (April-August 2011). Occupants were asked about their 'right-now' opinion of indoor environmental quality variables such as thermal and humidity sensation, air movement and comfort. Simultaneous physical measurements of air and radiant temperature, relative humidity and air speeds were also recorded. We analyse the results examining the physical conditions and thermal comfort responses in both the zones, and adaptive actions exercised in the NV zone. We compare the observations from the NV zone to three adaptive comfort charts to evaluate whether comfort in the NV zone in a MM building can be modelled as a purely NV building.

Keywords: Mixed mode, zoned type, adaptive action, thermal comfort

1. Introduction

Since the development of the adaptive comfort theory, researchers have conducted many field studies in naturally ventilated (NV) and air-conditioned (AC) buildings to evaluate comfort and adaptive actions. NV buildings consume significantly lower energy as compared to AC and also maintain similar or improved comfort levels (Loftness et al., 2007). However, it is commonly found that a building is not always fully naturally ventilated or fully air-conditioned but sometimes combines both conditioning strategies; these are referred to as 'mixed mode' (MM) buildings. The temporal and spatial method of cooling the space further classifies the mixed mode building as changeover, zoned and concurrent type (Center for the Built Environment-mixed mode website). The MM buildings discussed in this paper are all zoned type; part of the floor area is conditioned and the rest naturally ventilated. From now on they will be referred as 'AC zone' and 'NV zone' respectively.

MM buildings have a great potential for energy efficient design when the major responsibility of maintaining appropriate space temperature is borne by passive design elements, and air-conditioners are used only to meet programmatic requirements such as computer lab/conference room, or weather conditions with overly warm

temperatures. MM buildings also perform well as compared to purely NV and purely AC buildings in thermal comfort and air quality (Brager and Baker, 2009).

Although MM buildings are becoming common, there are not many studies that have evaluated comfort and adaptation in these buildings. Studies that have led to the adaptive comfort standards show clear evidence that occupants in NV buildings are comfortable over a broader temperature range than in AC (ASHRAE Standard 55, 2004, Brager and de Dear, 1998, Nicol and Humphreys, 2002); the unresolved question is whether the adaptive theory can be extended to MM buildings. In a zoned MM building, occupants in the NV zone frequently shuttle to the AC zone during the day and are aware of the environmental conditions in the AC zone. As a result, they might have higher comfort expectations. Contrary to this point, access to adaptive opportunities like operable windows and fans might outplay the expectancy factor. In a zoned type MM building studied in Sydney Australia, occupants in the NV zone adapted using passive means and accepted a wider indoor temperature compared to AC zone (Rowe, 2004). Testing the hypothesis of expectation in a switchover type MM building, Deuble and de Dear found that status of the air-conditioner influenced occupant's thermal response. When the physical conditions were associated with a PMV value of +1, the actual occupant votes revealed a warmer thermal response in AC mode as compared to NV mode (Deuble and de Dear, 2012).

Understanding thermal expectation, comfort response and physical environmental conditions in a MM building is crucial for a developing country like India where it is estimated that two-thirds of the commercial area needed by 2030 is yet to be built (Singh et al., 2013). Room air-conditioner sales are fast growing and have doubled from 400,000 units in 2006 to 800,000 units in 2011, accounting for highest energy consumption in the energy sector. The estimated installed inventory of AC's by 2016 is 10.2 million which, needless to say, would mount unrealistic pressure on power plants (Phadke et al., Natural resources defense council (NRDC), 2013, World Bank report, 2008).

Designers have a choice for these buildings that are yet to be built; seal them completely and install air-conditioners or adopt a more sustainable approach of selectively air-conditioning spaces only when and where needed, and design the rest of it to be naturally ventilated by deploying rigorous passive design strategies. To be able to opt for the later, the environmental conditions and the corresponding influence of expectancy on the occupants in the NV zones of a zoned type MM building needs to be characterized.

Specifically, the objectives of this analysis of the field study data are:

1. Evaluate the temperature, humidity, air speed and CO₂ concentration in the AC and NV zones.
2. Evaluate the adaptive control actions of window, fan, blind/curtain and balcony door operation in the NV zones.
3. Evaluate thermal comfort responses (thermal sensation/comfort) in the AC and NV zones.
4. Evaluate whether the NV zone of MM buildings can be modelled as a purely NV building, using the existing adaptive comfort model.

2. Methodologies

A transverse field study was conducted in the hot and dry climate of Jaipur, India, including 2869 total survey responses (1418 responses were from 17 purely naturally ventilated buildings, 642 from 6 purely AC, and 809 from 13 mixed mode buildings, out of which 560 were from 11 zoned type buildings.). Amongst the 560 responses, 274 responses were from NV and 286 were from AC zone; both having desk based work. Mixed mode observations were recorded only during summer (April- August).

The survey asked occupants about their clothing and activity patterns; thermal sensation, comfort, humidity and air movement sensation; temperature and air movement preference; and a few personal history questions, such as the use of air- conditioners at home and in cars. Using the class-II protocol of field measurement (de Dear, 1998), the study recorded parameters such as indoor temperature, relative humidity, mean radiant temperature and air velocity. Data about adaptive actions such as operating fans, windows, doors and blinds/curtains was also collected.

A weather station installed on a university campus (within 5 km radius of the surveyed buildings) recorded outdoor air temperature, humidity, rainfall, wind speed and direction.

3. Descriptive statistics

3.1. Climate analysis

Jaipur is a hot and dry climate. Summers are from the month of April to October with hot afternoons (mean = 30.97 °C, SD = 4.5 °C, maximum = 43 °C) (Figure 1). Mean value of relative humidity during summer is 53%. Winters are cold and occur during the months of November – February (mean = 19.8 °C, SD = 4.7 °C, lowest = 7.2 °C) and mean relative humidity during winter is 41%.

Warm wind is prevalent during summer (Figure 2); outdoor wind speed in summer (mean = 4.73 m/s, SD = 2.26 m/s) is higher than winter (mean = 2.94 m/s, SD = 1.7 m/s).

The weather is mainly cooling-dominated and thus presents a challenge for designing an energy efficient building that minimizes air-conditioning use, while also providing comfort.

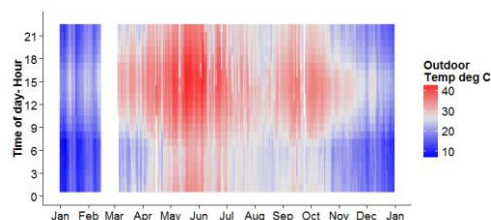

Figure 1 Heatmap of Jaipur weather

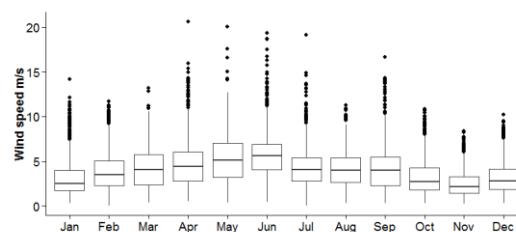

Figure 2 Outdoor wind speed

3.2. Age/gender distribution

India is witnessing an increase in the working age ratio which bestows upon it a 'demographic dividend' for economic growth (Aiyar and Mody, 2011). This finding has subtle implications on thermal comfort evaluation and design of future low energy

buildings. The young working age population (below 35 years of age) represents the future demands for comfort and understanding their current thermal opinion can help map out the pattern of comfort expectation. In our dataset the percentage of occupants below the age of 35 is 63% in the ‘NV zone’ and 57% in ‘AC zone’ (Figure 3).

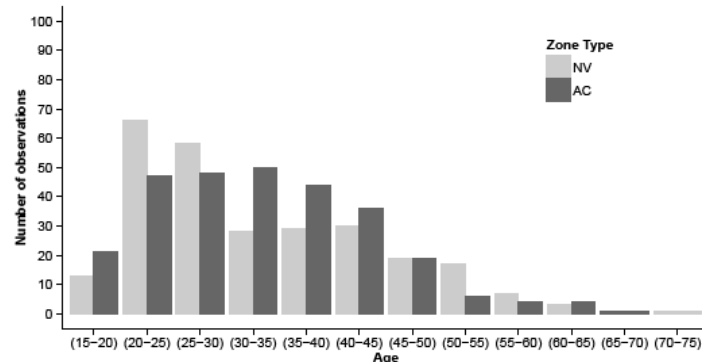

Figure 3 Age distribution in NV/AC zone

4. Physical measurements

4.1. Temperature/humidity distribution

Indoor operative temperature in the AC zone floated between 23 – 29°C while the NV zone indoor temperature was warmer, and ranged between 29 – 36°C (considering only those bins with more than 20 observation). Humidity level was also affected by the presence of AC, as would be expected. Humidity was maintained below 50% in 91% of the ‘AC zone’ observations, while the humidity shot above 50% in 50% of the NV zone observations (Figure 5). This significant difference in temperature and humidity between the AC and NV zone is particularly important because these two variables are of great concern while designing MM buildings in tropical climate. Other studies conducted in tropical climate have found that occupants are acceptable of higher indoor temperature and humidity in NV buildings (Nicol, 2004, Busch, 1992, Indraganti, 2010, Mallick, 1996). We test this hypothesis in this paper for the unique situation in a MM building where the occupants in the NV zone are well aware of the lower temperature and humidity in the AC zone.

Figure 6 shows the indoor – outdoor temperature occurrences in both the zones. The dotted line is where the indoor temperature equals outdoor. Interestingly, indoor stayed cooler than outdoors for 80% of the observations in the NV zone. This was mainly because the NV zones were shielded from direct solar radiation (by balconies and corridors) in most of the buildings and the construction material had high thermal mass. These buildings were constructed with conventional building practices such as double height ceiling, low window to wall ratio (20 – 30%), thick stone walls with plaster on both sides (330 mm) and also brick construction (double brick type - 229 mm) with plaster.

Overlaying the observations on the psychrometric chart (Figure 7) shows that 58% of the observations from the AC zone were inside the comfort zone defined by ASHRAE Standard 55. When the physical observations were inside the comfort zone, in 99% of these occurrences the occupants voted that they were comfortable. However, even when

the physical observations were outside the comfort zone, there was still a high number - 93% who were comfortable. The NV observations were clearly outside the comfort zone. In these NV zone observations, occupants voted to be comfortable 80% of the time when indoor temperature was less than 33 °C.

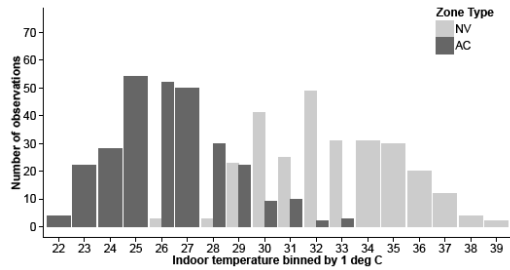

Figure 4 Indoor temperature distribution in NV/AC zone

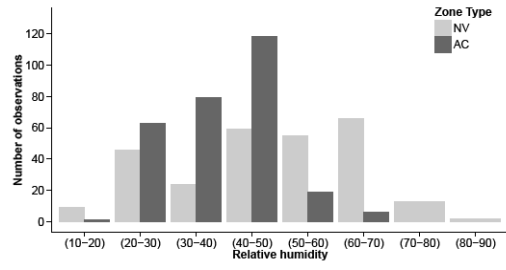

Figure 5 Humidity distribution in AC/NV zone

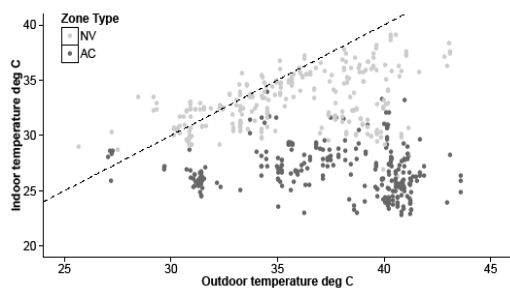

Figure 6 Indoor/outdoor temperature distribution in NV/AC zone

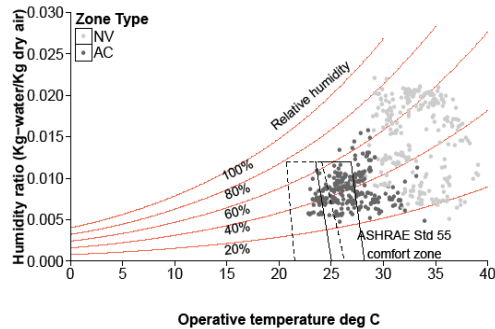

Figure 7 Observations overlaid on the psychrometric chart

4.2. Humidity sensation and air movement in NV zone

Although, Jaipur has a dry climate, 50% of the observations in the NV zone were found to have relative humidity above 50%. Figure 8 shows the humidity sensation of occupants in the NV zone for different relative humidity bins. Although humidity sensation is above neutral for relative humidity above 50%, the median lies at “Slightly humid” and there were negligible votes at “Very humid”. The forgiving humidity sensation could be because of air movement, which is shown in Figure 8 for different temperature bins, for both the NV and AC zones. Air movement is seen to be significantly higher ($p < 0.05$) in the NV zone compared to the AC zone in two of the four temperature bins with overlapping observations (represented by a solid dot just above the x axis). The horizontal dotted line shows the ASHRAE recommended limit for draft 1.2 m/s (ASHRAE Standard 55 2010b). Based on these physical measurements, 24% of the observations in the ‘NV zone’ were found to have air speed more than 1.2 m/s while it was only 3% in the ‘AC zone’. In the NV zone, mean air speed for indoor temperatures above 25°C was 0.9 m/s, which is higher than the mean air speed found for Pakistani subjects (0.45 m/s) in NV buildings in the same indoor temperature range (Nicol et al., 1999).

Investigating the indoor air speed at high humidity, Figure 9 shows the range of air speed for different relative humidity bins. We do the analysis just for the NV zones since humidity above 50% was rarely observed in the AC zones (Figure 5). Air speed at humidity above 50% in the NV zone is quite high around 1 m/s (Figure 9). The high

air velocity in the NV zone hints at occupant's tendency to use windows and fans to keep themselves comfortable at higher temperature and humidity, as observed in other field studies carried out in NV buildings in tropical (Cândido et al, 2011; de Dear et al, 1991; de Dear and Fountain, 1994; Mallick, 1996; Nicol, 2004; Sharma and Ali, 1986)

The mixed mode configuration brings forth another perspective to the findings; can comfort be provided in the NV zone by ensuring adequate opportunities to adjust air movement in the space, even when occupants are intermittently exposed to conditions of the AC zone where comfort is achieved predominantly by temperature control?

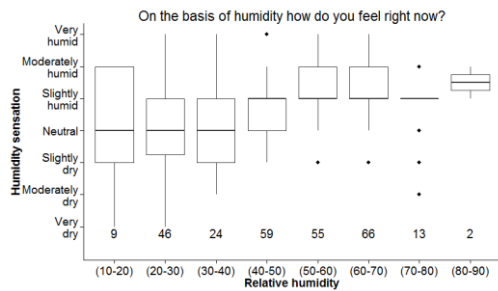

Figure 8 Humidity sensation binned by relative humidity in NV zone

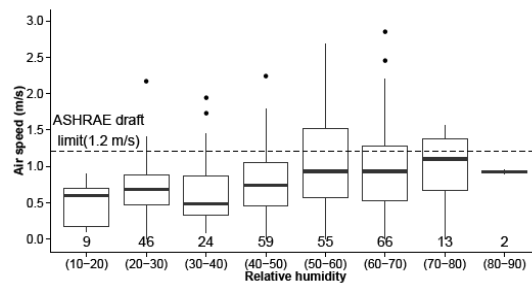

Figure 9 Air velocity binned by relative humidity in NV zone

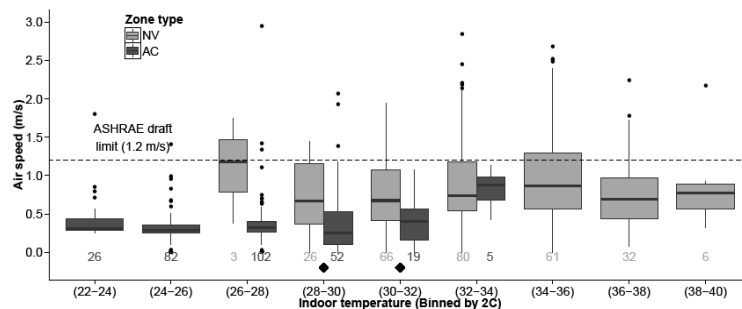

Figure 10 Air speeds in NV/AC zone binned by indoor temperature

4.3. CO₂ concentration

Significant relationship between sick building syndrome and CO₂ concentration has been observed at a threshold of 800 ppm (Apte et al., 2000). Results from CO₂ monitoring show that concentrations in the NV zone are much better than in the AC zone. 88% of the observations in the NV zone have a CO₂ concentration less than 800 ppm as compared to only 51% in the AC zone (Figure 11). Surprisingly, 50% of the observations in the AC zone recorded CO₂ concentration of above 2400 ppm. This could be because windows were never opened in the AC zones and they did not have any provision for mixing fresh air especially in offices with high occupancy. For comparison, the average office floor area per occupant in government offices the US is 20 m², while it is only 5-10 m² in Indian offices (Singh et al., 2013). Although a short-term exposure to CO₂ concentration above 2400 ppm is not harmful to health, it can prove to be a concern if the conditions prevail for a long time. The high CO₂ concentrations can also cause discomfort due to bio effluents (Persily, 1997, ASHRAE Standard 62.1 2010a).

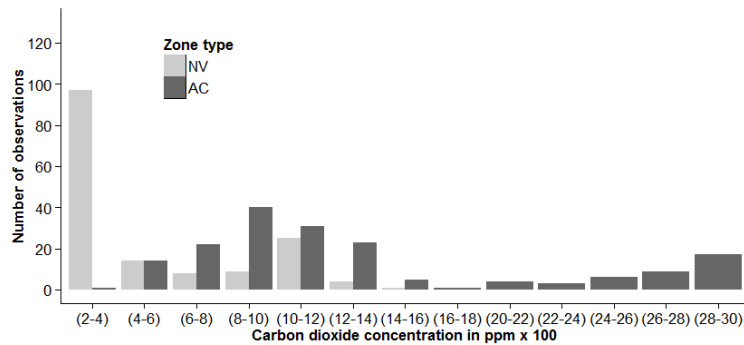

Figure 11 CO₂ concentration in NV/AC zone of MM building

5. Use of adaptive control in NV zone

Thermal comfort is directly influenced by behavioural adaptation in addition to psychological and physiological adaptation (Brager and de Dear, 1998). By extending the opportunities for behavioural adaptation in mixed mode buildings compared to conventional sealed buildings, the question becomes whether occupants in the NV zone use these adaptive actions to the same degree as in purely NV buildings. European and Pakistani mixed mode buildings have been found to follow similar control patterns of window opening and fan operation as in purely NV buildings (Rijal et al., 2008). In this paper, we do a descriptive analysis of window, fan, blind and balcony door use in the NV zone per degree indoor temperature to evaluate the proportion of usage in each bin. We chose indoor over outdoor temperature as the metric for binning because it captures the information at the individual building level which might vary from building to building for the same outdoor temperature, as noted by Robinson (Robinson, 2006).

5.1. Windows

Windows in the AC zone were closed in all the observations while those in the NV zone were sparingly opened; only 38% open overall (Figure 12). The bar graph does not show any clear trend and it seems like fewer windows are opened at indoor temperatures above 37°C. This might be because outdoor temperature is warmer than indoors in 80% of the observations (

Figure 6). The benefit of purging the warm indoor air and the disadvantage of bringing in even warmer outdoor air seem to be acting against each other.

5.2. Fans

Fans were found to be on in 98 % of the observations in the NV zone. This result is contrary to other studies that found windows to be the most widely used control option (Haldi and Robinson, 2008, Liu et al., 2012). However, the high percentage of fan use reveals that occupants like to have air movement. It also partially explains the window opening behaviour; when the outdoor temperatures are higher than indoors, occupants prefer to keep their window closed and turn on the fans to provide air movement, which is an appropriate strategy.

5.3. Blinds/curtains

Adjusting blinds is an important adaptation strategy in tropical climates since direct sunlight or glare is thermally and visually unpleasant at high indoor temperatures. Overall, 68% of the blinds were found to be open in the NV zone (Figure 14). Fewer

blinds were found open as the indoor temperature increased above 33°C, possibly to avoid heat gain and glare.

5.4. Balcony doors

Overall, 72% balcony doors were open. Balconies are an integral part of climate responsive building design in tropical climates as they act as thermal buffer zones, reducing the direct solar exposure to the interiors while providing air movement. In most of our buildings, balconies were located on the side of the façade that received direct sunlight; towards South and South-west.

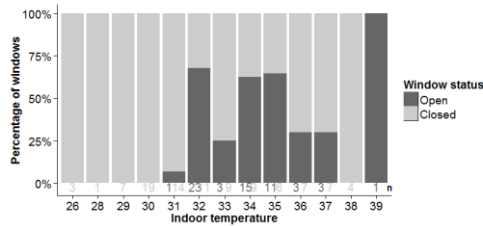

Figure 12 Percentage of windows open/closed in the NV zone of MM

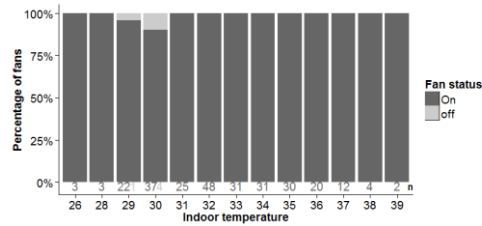

Figure 13 Percentage of fans on/off in the NV zone of MM

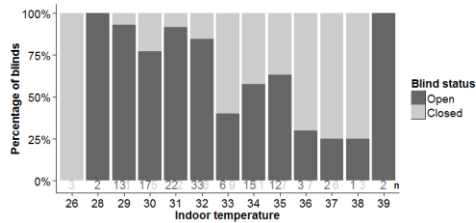

Figure 14 Percentage of blinds open/closed in the NV zone of MM

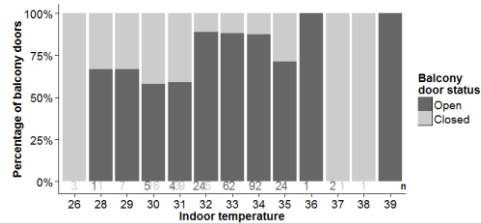

Figure 15 Percentage of balcony doors open/closed in the NV zone of MM

5.5. Comparison with purely NV buildings

In the 17 purely naturally ventilated buildings surveyed and monitored in this study, similar degree of adaptive control usage was observed for windows and fans. Overall, windows were open in 33% and fans were turned on in 81% of the observations. Interestingly, all of the 42 observations at indoor temperature above 36 °C had windows open. Blinds were open in 58% while balcony doors were open in 83% of the observations.

6. Thermal comfort

6.1. Thermal sensation in AC and NV zone

Overall, occupants in 70% and 87% of the observations in NV and AC zones, respectively, voted within the thermal sensation limit of ± 1 (slightly cool – slightly warm). Figure 16 shows the box plot of thermal sensation votes in both the zones for bins of indoor temperature. When the indoor temperatures were between 30°C – 38°C in the NV zone, the median value of thermal sensation was “slightly warm”. This indicates that occupants in the NV zone do not feel overly warm at higher indoor temperatures and adapt themselves to the indoor conditions using controls such as operable windows, fans, blinds and balcony door. This is particularly interesting because of the expectancy factor discussed earlier, where there was concern that NV occupants’ visits to the AC zones would lead to their desire for cooler temperatures.

Our results show that adaptation to the warmer temperatures in the NV zone overrides expectation that may have been influenced by the AC zone.

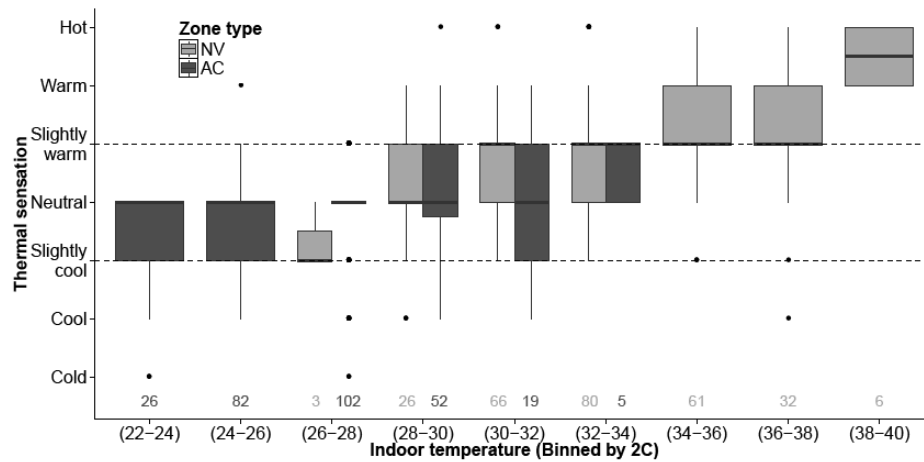

Figure 16 Thermal sensation Indoor temperature range

6.2. Relation between thermal sensation and comfort

The most appropriate metric for thermal comfort has often been debated because of its inherent subjective definition. The ASHRAE Standard 55 adaptive model uses thermal sensation as the metric to calculate the percentage of people satisfied. However, thermal sensation doesn't necessarily reflect an occupant's comfort opinion. An occupant might vote that to feel warm, but may still be comfortable. This might be due to the three adaptations pointed out in the adaptive comfort theory- behavioural, physiological and psychological, or because of the pleasant experience in transient temperature conditions (Brager and de Dear, 1998, Kuno, 1995).

In our survey, occupants recorded their comfort opinion on a scale of 5 (Very uncomfortable- Very comfortable). Figure 17(NV) and Figure 18(AC) shows percentage of occupants comfortable (colour), binned per degree indoor temperature and thermal sensation. Only those bins with five or more observations are shown. Interestingly, the range of thermal sensation is much broader in the NV zone on the warmer side while it is broader on the cooler side in the AC zone. In the NV zone, when the indoor temperature was between 30-35°C, occupants voted to be "neutral" or "slightly warm" in 73% of the observations (123 out of 169). Out of these 123 observations, 84% were comfortable (Figure 17). Occupants in the AC zone voted to be comfortable in 96% of the observations (Figure 18). However, there are some slightly cool and cool votes that occur at indoor temperature of 24 -27°C which shows that these AC zones run a potential risk of overcooling the building. The comparison of thermal sensation and comfort between NV and AC zone illustrates that in a hot-dry climate, air-conditioners do a good job in providing comfort, but it is also possible to keep occupants comfortable without having to use an air-conditioner.

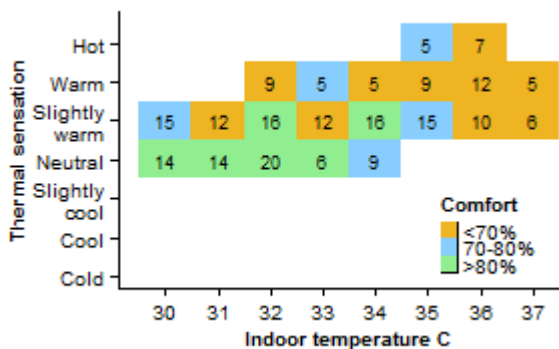

Figure 17 Percentage comfortable per degree indoor temperature and thermal sensation in NV zones

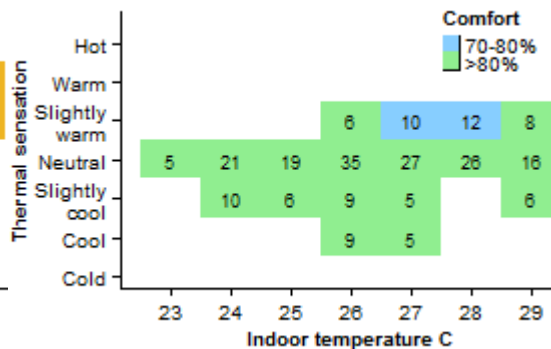

Figure 18 Percentage comfortable per degree indoor temperature and thermal sensation in AC zones

6.3. Comfort temperature range in NV and AC zone

In the NV zone more than 70% occupants voted to be comfortable per degree indoor temperature ranging from 29°C – 34°C, while in the AC zone the range was 23°C – 29°C (considering only those bins with more than 20 votes). The higher comfort temperature range in the NV zone clearly supports the adaptive theory which posits the acceptance of a wider range of comfort temperature. The upper limit of the observed comfort range in the AC zone is also higher than the one defined in ASHRAE Standard (Figure 7), which basically means occupants in the AC zone also adapt to warmer than neutral indoor temperatures.

When viewed from the perspective of a mixed mode building, the comfort range presents an interesting scenario. Two groups of people in the same building are exposed to a relatively low and high temperature range (AC and NV zone). The ones in the lower temperature range are comfortable; but the majority of those in the higher temperature range, barring a few observations when the indoor temperature is greater than 35 °C, are also comfortable. This is a promising result for new constructions in tropical climates which can rely more on passive design to provide comfort cost efficiently.

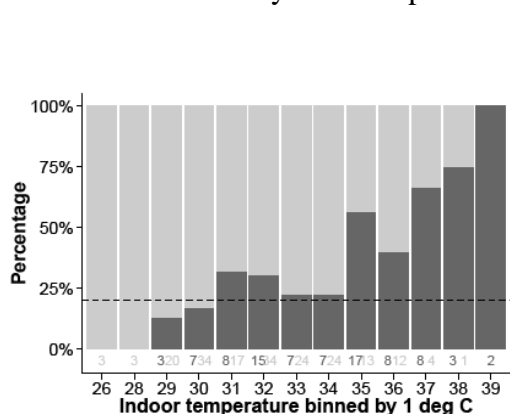

Figure 19 Percentage people dissatisfied in NV zone binned by indoor temperature

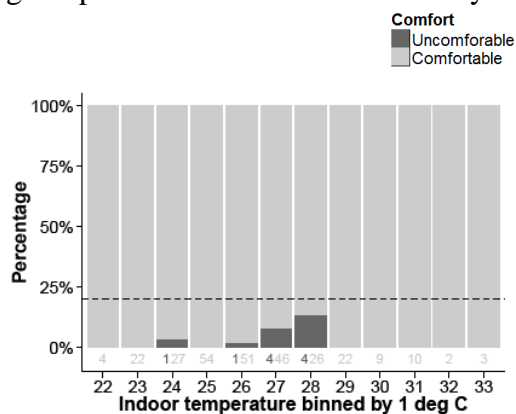

Figure 20 Percentage people dissatisfied in AC zone binned by indoor temperature

6.4. Comparison of NV zone temperature with ASHRAE Standard 55, EN 15251 and an adaptive chart developed for hot-humid Indian climate

ASHRAE adaptive standard 55 gives a relation between running mean temperature and comfort temperature in an unconditioned building, but does not provide any guidelines for modelling comfort in a mixed mode building. However, it allows the comfort model to be applied in spaces that do not have a mechanical cooling system installed (ASHRAE Standard 55, 2004). EN 15251, on the other hand, gives similar relationship between comfort and running mean temperature while extending the applicability of the standard to spaces that have mechanical conditioning installed but not in operation (Nicol and Humphreys, 2002). Technically, both the adaptive models can be applied to the NV zone of a mixed mode building.

To verify this hypothesis of applicability of the adaptive models in the NV zone, we compare the percentage of people comfortable in our study with the ASHRAE Standard 55, EN 15251 and an adaptive model developed for hot-humid climate of South India (Indraganti et al., 2014) (Figures 20-22).

Only 53% (145 out of 274) of the observations in the NV zone were in the temperature range where ASHRAE adaptive chart is applicable (i.e., running mean outdoor temperature less than 33°C) (Figure 21). Of the 274 total NV zone observations, only 20 were inside the 80% satisfaction zone (outermost lines) defined by the adaptive chart (Figure 21), and 85% of these 20 occupants voted that they were be comfortable. But there was still a very high level of comfort above the adaptive comfort zone limits. In the area above the 80% satisfied limit, but below the running mean 33°C limit of applicability (shown in a dotted blue line), 75% occupants were comfortable. When running mean was greater than 33 °C, occupants voted comfortable in 60% of the 129 observations.

Comparing with EN 15251 standard (Figure 22), only 57 of the 274 observations fell in the temperature zone where the adaptive chart is valid (running mean temperature less than 30 °C). This is probably because EN 15251 was developed from field study data from European countries, which did not have hot summers like Jaipur (Nicol and Humphreys, 2002). We do not evaluate further with respect to EN15251 due to the limited number of valid votes.

For the adaptive chart developed from a field study in hot-humid climate of South India (Indraganti et al., 2014), 53% observations from the NV zone were within the temperature range where the chart was valid (running mean temperature less than 33 °C) (Figure 23). Considering $\pm 4K$ deviation from neutral temperature as the comfort threshold, 81% occupants voted to be comfortable inside the comfort zone. Out of the 56 observations that were outside the comfort range, 70% were comfortable.

These results indicate two things:

- The NV zone of mixed mode can be modelled as a purely naturally ventilated building, while noting that in this particular study we found high degrees of comfort at temperatures even high than the recommended upper limits
- Amongst the three adaptive charts compared above, ASHRAE Standard 55 and the adaptive model developed by Madhavi et.al. best represent comfort from this tropical climate better than EN15251.

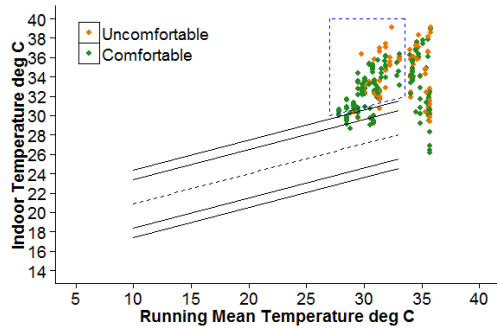

Figure 21 Comfort votes from NV zone overlaid on the ASHRAE Standard 55 adaptive chart

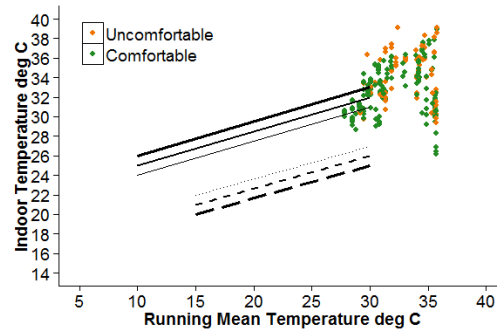

Figure 22 Comfort votes from NV zone overlaid on EN 15251 adaptive chart

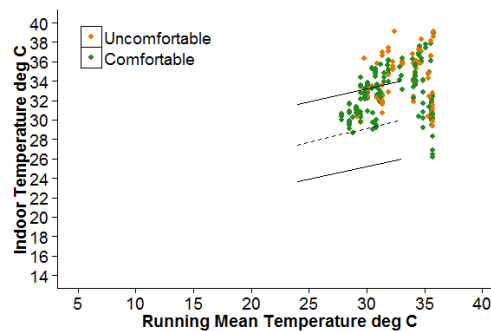

Figure 23 Comfort votes from NV zone overlaid on adaptive chart developed by Madhavi et.al. for South Indian climate

7. Discussion

Physical measurements and thermal comfort survey responses from this study shows that a zoned-type mixed mode building has the potential to save energy and also provide comfort.

Indoor temperatures in the NV zones were found to be on an average 2 - 5 °C lower than outdoor temperature even when the outdoor temperature was above 35°C (Figure 6). In addition to revealing that the building envelope is performing well in a hot-dry climate, this result when viewed in the light of thermal comfort raises an interesting question- Is the comfort opinion of a space driven by the difference in indoor and outdoor temperature, as opposed to the absolute value of either one of them? In other words, if it is very hot outside a temperature drop of few degrees indoors could be sufficient to keep occupants comfortable.

High air speeds at higher relative humidity and temperature, apparently due in part to the frequent turning on of fans in the NV zone, shows that occupants prefer to have air movement. In addition to this, 70 - 80% comfort at a high indoor temperature range of 29 - 34 °C is an evidence of thermal adaptation where occupants are comfortable beyond the neutrality defined by the uniform conditioning-based PMV method. Occupants' ability to adapt to the high humidity and temperature in the NV zone by accessing windows, fans, blinds and doors seem to override any potential expectations of having conditions similar to AC zone. This implies that a building can be selectively air conditioned based on programmatic requirement or zone location (perimeter and core), while the other areas can be designed as a naturally ventilated building, and one still gets the benefits of adaptive comfort.

The higher temperature range for comfort in the NV zone also gives designers an opportunity to explore various passive design strategies in hot-dry climates that reduce indoor temperatures, which might not be far enough to meet the neutral temperature defined by the PMV based method. Studies evaluating the performance of passive design in hot-dry Indian climates, such as using passive downdraft cooling towers, have reported energy saving as high as 64% compared to air conditioned building (Ford et al., 1998), and a temperature reduction in the range of 12 °C – 14 °C. Other passive strategies that have been found to be effective are mud walls, thermal insulation over roof and nocturnal cooling (Ford et al., 1998, Chel and Tiwari, 2009, Nahar et al., 2003).

Although experiences in the AC zones did not seem to influence thermal expectations of occupants of the NV zone in our study, these results cannot necessarily be extended to a switchover type mixed mode building. The unanswered question in a switch over type MM building is - would installing an air conditioner influence the adaptive actions that occupants would have otherwise exercised, such as opening a window or turning on a fan?

Designers encounter two main challenges in a switchover type MM building. For a system that switches between NV and AC automatically, there does not seem to be a standard for deciding the temperature at which the switch over would happen. If the decision to switch on and off the air conditioner is left to the occupants, there is no certainty that occupants would actually turn off the air conditioner when the outdoor weather is suitable to open windows. Mutual consensus between occupants to turn off the air conditioner would also be a challenge.

In light of these difficulties, zoned type mixed modes have an advantage over switchover types. The energy saving in the unconditioned area is guaranteed and there are fewer concerns of HVAC control. Strategic location of programs within a building considering cooling requirements and appropriate use of passive design seems to be a promising way of reducing the cost of comfort in the 70% of the buildings that are yet to come up in India.

8. Conclusions

Overall, the mixed mode buildings are performing well in providing comfort in the hot and dry climate of Jaipur. Specific conclusions from this study are

- Indoor temperatures in the AC zone (23 – 29 °C) are much lower than the NV zone (29 – 36 °C) but occupants in the NV zone vote to be neutral or slightly warm in 71% of the observations and are comfortable during the significant majority of the times.
- Relative humidity in the NV zone ranged from 36 – 86% while in the AC zone it ranged between 31- 66%. In both zones, occupants rarely complained about feeling very humid.
- Fans were found to be turned on in 98% of the observations in the NV zone with high air speeds (mean = 0.9 m/s), indicating that occupants in prefer to have air movement.
- The comfort temperature range in which 80% of the people were satisfied was found to be 23 – 29 °C in the AC zone, compared to 29 – 34 °C in the NV zone.
- The ASHRAE Standard 55 adaptive model and the adaptive model developed by Madhavi et.al best modelled comfort in the NV zone of the MM buildings in a hot-dry climate.

- The opportunity to adapt to the warmer environments in the NV zone by use of windows, fan, blinds and doors overrides the possible increase in thermal expectation from intermittent exposure to AC zone.

Acknowledgements

This work was funded in part by the US - India Joint Clean Energy Research and Development Center (JCERDC) under the framework of the Center for Building Energy Research and Development (CBERD) project supported by the US-India Science and Technology Forum and the U.S. Dept. of Energy.

We are grateful to Dr. G.D. Agarwal for his suggestions during field data collection and also to the subjects who willingly filled out the surveys.

References

- Aiyar S and Mody A (2011) Demographic Dividend: Evidence from the Indian States. International Monetary Fund.
- ANSI/ASHRAE (2010a) ANSI/ASHRAE 62.1-2010: Ventilation for acceptable indoor air quality. *American Society of Heating, Refrigerating and Air-Conditioning Engineers*, Atlanta.
- ANSI/ASHRAE (2010b) Standard 55-2010 addendum.
- Apte MG, Fisk WJ, Daisey JM (2000) Associations between indoor CO₂ concentrations and sick building syndrome symptoms in U. S. office buildings: An analysis of the 1994-1996 BASE study data. *Indoor air*, 10, 4, 246-257.
- ASHRAE (2004) ASHRAE Standard 55 - 2004 Thermal Environmental Conditions for Human Occupancy.
- Brager GS and Baker L (2009) Occupant satisfaction in mixed-mode buildings. *Building Research & Information*, 37, 4, 369-380.
- Brager GS and de Dear RJ (1998) Thermal adaptation in the built environment: A literature review. *Energy and Buildings*, 27, , 83-96.
- Busch JF (1992) A tale of two populations: Thermal comfort in air-conditioned and naturally ventilated offices in thailand. *Energy and Buildings*, 18, 3-4, 235-249.
- Cândido C, de Dear R, Lamberts R (2011) Combined thermal acceptability and air movement assessments in a hot humid climate. *Building and Environment*, 46, 2, 379-385.
- Center for the Built Environment Mixed Mode: Case Studies and Project Database. Available at: <http://www.cbe.berkeley.edu/mixedmode/aboutmm.html> .
- Chel A and Tiwari GN (2009) Thermal performance and embodied energy analysis of a passive house – case study of vault roof mud-house in India. *Applied Energy*, 86, 10, 1956-1969.
- de Dear RJ (1998) A global database of thermal comfort field experiments. *ASHRAE Transactions*, 104, 1b, 1141-1152.
- de Dear RJ and Fountain ME (1994) Field experiments on occupant comfort and office thermal environments in a hot-humid climate. *ASHRAE Transactions*, 100, 2, 457-475.
- de Dear RJ, Leow KG, Foo SC (1991) Thermal comfort in the humid tropics: Field experiments in air conditioned and naturally ventilated buildings in Singapore. *International Journal of Biometeorology*, 34, 259-265.
- Deuble MP and de Dear RJ (2012) Mixed-mode buildings: A double standard in occupants' comfort expectations. *Building and Environment*, 54, 53-60.

- Ford B, Patel N, Zaveri P et al (1998) Cooling without air conditioning: The torrent research centre, ahmedabad, India. *Renewable Energy*, 15, 1, 177-182.
- Haldi F and Robinson D (2008) On the behaviour and adaptation of office occupants. *Building and Environment*, 43, 12, 2163-2177.
- Indraganti M, Ooka R, Rijal HB et al (2014) Adaptive model of thermal comfort for offices in hot and humid climates of India. *Building and Environment*, 74, 39-5.
- Indraganti M (2010) Thermal comfort in naturally ventilated apartments in summer: Findings from a field study in hyderabad, India. *Applied Energy*, 87, 3, 866-883.
- Kuno S(1995) Comfort and pleasantness. , Nagoya, Japan, March 1995.
- Liu W, Zheng Y, Deng Q et al (2012) Human thermal adaptive behaviour in naturally ventilated offices for different outdoor air temperatures: A case study in changsha china. *Building and Environment*, 50, 76-89.
- Loftness V, Hakkinen B, Adan O et al (2007) Elements that contribute to healthy building design. *Environmental Health Perspectives*, 115, 965-970.
- Mallick FH (1996) Thermal comfort and building design in the tropical climates. *Energy and Buildings*, 23, 3, 161-167.
- Nahar N, Sharma P, Purohit M (2003) Performance of different passive techniques for cooling of buildings in arid regions. *Building and Environment*, 38, 1, 109-116.
- Natural resources defense council (NRDC) (2013) Cooling India with less warming: The business case for phasing down HFCs in room and vehicle air conditioners.
- Nicol JF, Raja IA, Allaudin A et al (1999) Climatic variations in comfortable temperatures: The pakistan projects. *Energy and Buildings*, 30, 3, 261-279.
- Nicol JF and Humphreys MA (2002) Adaptive thermal comfort and sustainable thermal standards for buildings. *Energy and Buildings*, 34, 6, 563-572.
- Nicol F (2004) Adaptive thermal comfort standards in the hot-humid tropics. *Energy and Buildings*, 36, 7, 628-637.
- Persily AK (1997) Evaluating building IAQ and ventilation with indoor carbon dioxide. *TRANSACTIONS-AMERICAN SOCIETY OF HEATING REFRIGERATING AND AIR CONDITIONING ENGINEERS*, 103, , 193-204.
- Phadke A, Abhyankar N, Shah N Avoiding 100 new power plants by increasing energy efficiency of room air conditioners in India: Opportunities and challenges.
- Rijal H, Humphreys MA, Nicol JF (2008) How do the occupants control the temperature in mixed-mode buildings? predicting the use of passive and active controls. *In: Proceedings of Air Conditioning and the Low Carbon Cooling Challenge Windsor, UK.*
- Robinson D (2006) Some trends and research needs in energy and comfort prediction. *In: Proceedings Windsor conference, UK*
- Rowe DM (2004) Thermal comfort in a naturally ventilated environment with supplementary cooling and heating. *Architectural Science Review*, 47, 2, 131-140.
- Sharma M and Ali S (1986) Tropical summer index—a study of thermal comfort of Indian subjects. *Building and Environment*, 21, 1, 11-24.
- Singh R, Sartor D, Ghatikar G (2013) Best practices guide for high- performance Indian office buildings.
- World Bank report (2008) Residential consumption of electricity in India: Documentation of data and methodology (draft report).

WINDSOR CONFERENCE 2014

COUNTING THE COST OF COMFORT

WORKSHOP 2

Schools and young people

Invited Chairs: Despoina Teli and Azadeh Montazami

WINDSOR CONFERENCE 2014

COUNTING THE COST OF COMFORT

THE WORKSHOP PROGRAMME

WORKSHOP 2: Designing Comfortable Schools in current and future climates

Invited Chairs: Despoina Telli and Azadeh Montazami

11th April 2014: 16.30 – 18.30 – Hodgson Room (2 Hours)

The health and performance of students and teachers in school buildings are influenced by indoor environmental parameters such as noise levels, indoor temperature, humidity, air quality and light. Providing good environmental conditions with minimum energy use in schools has always been a concern in design guidelines around the world. The growing necessity to save energy in an uncertain future whilst providing a good indoor environment suggests that school designers should approach design more holistically in order to provide comfort and at the same time reduce the gap between design and achieved building performance. The workshop opens with a short presentation on four key topics introduced by the workshop leaders, based on their own research experiences. Then three papers will be presented that have been chosen to illuminate the issues and a lively discussion will hopefully shed light on the topics. The core topics School Design Guidelines correct, Climate Change, Behaviours and researching into related attitudes.

Proceedings of 8th Windsor Conference: *Counting the Cost of Comfort in a changing world* Cumberland Lodge, Windsor, UK, 10-13 April 2014. London: Network for Comfort and Energy Use in Buildings, <http://nceub.org.uk>

Occupants' behaviours in controlling blinds in UK primary schools

Azadeh Montazami¹ and Mark Gaterell²

1 Coventry University, UK, azadeh.montazami@coventry.ac.uk

2 Coventry University, UK, mark.gaterell@coventry.ac.uk

Abstract

The environmental conditions experienced in UK schools not only influence the effectiveness of teaching and learning but also affect energy consumption and occupant behaviour plays a critical role in determining such conditions. The aim of this study is to understand occupant behaviour in controlling window blinds in UK primary schools which not only mediate internal conditions but also influence the use of artificial lighting and consequently electricity consumption.

Occupant behaviour in controlling blinds against direct solar gain and glare through windows in 140 classrooms of 22 primary schools between 2007 and 2008 was studied through questionnaires, interviews and observations of blind status. Results show that on average blinds are closed very regularly in all the schools except one. This is due to a wish to prevent overheating, reduce glare and also limit the impact of distractions from outside, as some classrooms are located on the ground floor. Such behaviour affects both the effectiveness of teaching and learning and also electricity consumption and consequently a school's carbon footprint. It is also likely to be at least in part responsible for the gap between design the energy consumption predicted at the design stage and that actually experienced when the school is in use. Designers need to understand the implications of this behaviour to ensure they deliver effective, energy efficient spaces that perform as anticipated.

Key words: Occupant behaviour, control, primary school, classrooms, window, blind, curtain

1 Introduction:

Increasing demand for more energy efficient buildings means the construction industry needs to ensure that the energy performance predicted during the design stage is achieved post-occupation. However, evidence suggests that there is a significant gap between design and in-use performance (Demanele et al, 2010; Bordass et al, 2004; UBT, 2011; Bordass, 2001).

Figure 1 illustrates the predicted and actual electricity consumption in three building sectors: schools, general offices and university buildings. These data suggest there is a significant gap between the predicted and actual electricity consumption in school buildings.

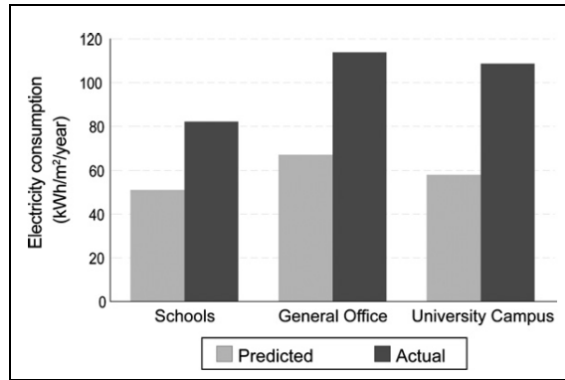

Figure 1. Electricity consumption per-sector – predicted vs. Actual (Menezes, A.C. et al., 2012.)

This gap is attributed to the lack of feedback to designers after handover, inhibiting improvements both to existing buildings and future designs. The practice of Post-Occupancy Evaluation (POE) aims to address this issue by evaluating the performance of a building after it has been built and occupied. Factors that contribute to the discrepancy in energy consumption are model simplification, changes to the building design between making predictions at the modelling stage and final construction, occupant behaviour, commissioning, and maintenance (Demanele et al, 2010; Menezes, 2012).

The UK Government has committed to reduce CO₂ emissions by at least 80% by 2050, relative to 1990 baseline levels (Global Action Plan, 2006). Currently, there are over 25,000 schools in the UK and in total they are responsible for approximately 14% of the UK public sector’s total carbon emissions (Climate Change Act, 2008). The Carbon Trust (2012) reported the energy consumption pattern for schools for both fossil fuels and electricity (Figure 2). According to this report, 16% is due to electricity consumption which is used for hot water, lighting, office equipment etc. with half (8%) used for lighting alone.

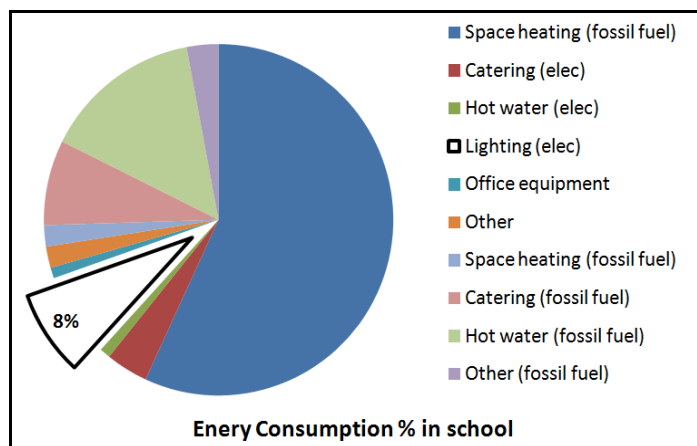

Figure 2. Electricity consumption profile for school (Source: Carbon Trust, 2012)

Exploring the reasons for the gap between designed and predicted electricity consumption is essential because of its high cost and carbon footprint. Also the use of natural light rather artificial light in schools is thought to have a positive impact on student health and performance (Walden.R, 2008).

Although only 8% of the total energy is consumed for lighting in schools (Figure 2), data in Figure 3 suggests the higher unit price and carbon intensity associated with electricity in comparison to fossil fuel energy mean such consumption is likely to account for approximately 20% of the overall energy costs and carbon footprint.

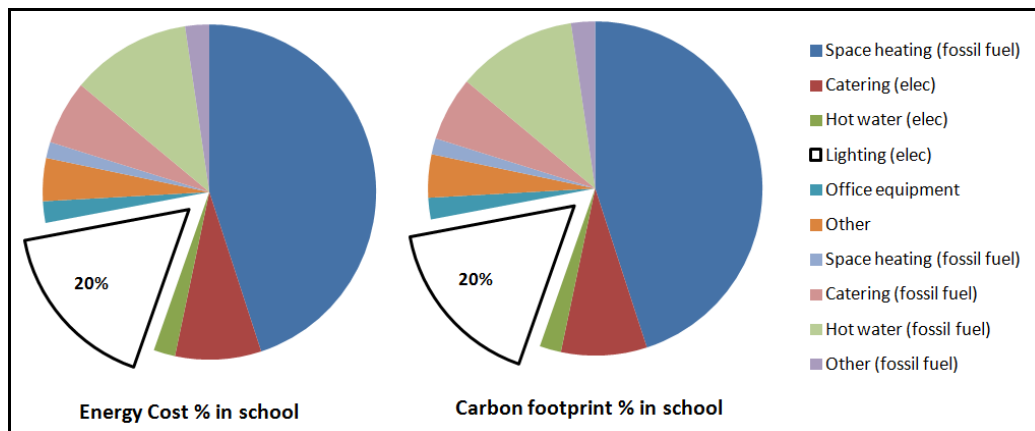

Figure 3. Cost and carbon foot print profile for school
 Cost profile (Source: Carbon Trust, 2012) - Carbon foot print profile (drawn by A. Montazami)

The level of natural light inside a building and, therefore, the likelihood of artificial lights being used, depends on the location of windows, window area, surrounding buildings, internal surfaces and occupants' behaviour in controlling blinds (BB90, 2003; CIBSE TM37, 2006). The main reasons for closing blinds in office buildings are visual comfort, thermal comfort and also distractions from outside (Inoue et al., 1988 ; Lindsay and Littlefair, 1992; Reinhart, 2004; Inkarojrit, 2005; Sutter et al., 2006 ; Sutter Y, 2006; Lindelöf and Morel, 2006; Inkarojrit, 2008 ; Foster and Oreszczyn, 2011). Clearly, where such devices are used in ways not anticipated by the building's designers, and result in the use of artificial light, the energy consumption profile is likely to higher than expected. Similar behaviour in schools could account for some of the performance gap outlined above.

It is important to note that not only does the use of natural light instead of artificial light have a significant impact on reducing the carbon foot print and cost for schools, but a good level of natural light also benefits the health and performance of students. A study by Taylor and Gousie (1988) suggests that lack of lighting comfort (in terms of lighting level, glare, spectrum etc) has a negative effect on students' physiological and psychological functions such as neuron doctrine functions, hyperactivity and task behaviour. Good natural lighting can only be achieved by combining direct and indirect lighting (Barnitt, 2003; Butin, 2000) and lighting controls such as blinds to provide an opportunity for adjusting lighting levels in classrooms (Butin, 2000). One of the main benefits of natural light is that it consists of all light spectra (full spectrum). Lack of adequate levels of light can increase fatigue, headaches and also damage eyesight, while a light which is too bright also has a negative impact on well-being. Glare can lead to diminished vision and headaches resulting from overexerting the eyes (CIBSE KS6, 2006). It has also been found that illness and mental fatigue can be reduced by the use of full spectrum natural light especially on children with hyperactivity disorder (Dunn et al., 1985). Performance improves in the presence of daylight and its positive effects are

manifested in better social behaviour. There is a significant relationship between students' academic attainment and natural daylight. Children's attention increases (Ott, 1976) and student absenteeism decreases (London, 1988) as a result of full spectrum natural light. According to the study carried out by Collaborative High Performance School (CHPS, 2006), students in well-lit classrooms had higher scores (up to 26%) on the New Stanford Achievement Test in comparison with the ones in poorly lit classrooms.

Through the study of occupant behaviour in controlling blinds in London primary school classrooms, this paper aims to understand why such devices are used, the potential implications of their use on light levels and consequently their likely role in the gap between predicated and actual electricity consumption. It also considers how occupant control affects various comfort factors and thereby influences our ability to deliver well-lit classrooms that increase students' productivity with the minimum carbon and financial cost.

2 Methodology:

This study is based on a case study approach using post occupancy evaluation (POE) and quantitative research techniques such as observation, taking photos and conducting interviews in the cooling seasons (i.e. June and July) of 2005, 2007 and 2008. The aim was to evaluate occupant behaviour in controlling blinds and the usage of windows in controlling overheating and glare during cooling seasons.

The UK school stock is a mixture of schools constructed in different eras with different characteristics (i.e. solar gain, thermal mass, ventilation potential, internal gain). The stock has previously been characterised in terms of Victorian, open-air, post-war and post-energy crisis schools (Montazami and Nicol, 2013). In this study 22 schools constructed in these different eras were selected (i.e. four Victorian, four Open-air, four Post-war and eight Post-energy crises) from three London boroughs of Hounslow, Haringey and Islington.

140 teachers from the selected classrooms participated in this study completing questionnaires during 2007 and 2008. Between one to ten questionnaires were filled out in each school. Unfortunately, the teachers of some schools refused to fill out the questionnaires both in 2007 and 2008. Interviews and the taking of photos of the teachers' behaviour in controlling blinds and the usage of windows were carried out by the lead author in 2005, 2007 and 2008. Table 1 shows the name of schools which participated in this study according to the era of the schools, the level of thermal mass in each school, the mode of ventilation and also the number of questionnaires filled out by the teachers in both 2007 and 2008.

Table1. School information and number of questionnaires filled out by the teachers in 2007 and 2008

Era	Victorian				Open air			Post war					Post energy crisis									
	AM	CL	FL	HF	CR	HS	WL	HL	NW	RO	MF	OC	AN	GC	SG	GR	LD	PP	MM	BR	BF	NT
Schools	Heavy Thermal mass				Low Thermal mass								Medium Thermal mass									
Ventilation Natural (N) / Mechanical (M)	N	N	N	N	N	N	N	N	N	N	N	N	N	N	N	N	N	N	N	M	M	N
2008	5	3	4	3	3	3	5	1	3	2	10	9	5	0	0	5	0	0	5	3	1	5
2007	0	0	6	4	6	0	3	0	5	0	0	0	8	0	0	6	3	0	9	3	6	6

The questionnaires focussed on collecting data on teachers' perceptions regarding the internal environment (i.e. thermal comfort, visual comfort, acoustic comfort and air quality), teachers' behaviour in controlling blinds, the reasons for closing blinds and also their level of control over the internal environment. The research questionnaire was based on that designed by 'Usable Building Trust' to evaluate the environmental conditions in offices. This questionnaire was the most relevant as it is can reflect the occupants' feelings regarding their internal environment. Observation has been used in a variety of disciplines as a tool for collecting data (Kawulich, 2005). In this study, observation followed by taking pictures is used as a method to record the teachers' behaviour in using windows in 9 out of the 22 schools.

Figure 4 shows the sets of questions designed to evaluate the internal environment factors in general.

Environmental factors evaluation									
Thermal Comfort	How would you describe thermal comfort in your classroom in summer term?								
	Uncomfortable	1	2	3	4	5	6	7	Comfortable
	Hot	1	2	3	4	5	6	7	Cool
Visual comfort	How would you describe overall lighting in your classroom in summer term?								
	Unsatisfactory	1	2	3	4	5	6	7	Satisfactory
Air quality	How would you describe quality of air in your classroom in summer term?								
	Stuffy	1	2	3	4	5	6	7	Fresh
Acoustic comfort	How would you describe acoustic in your classroom in summer term considering noise sources fom outside your classroom?								
	Noisy	1	2	3	4	5	6	7	Quiet

Figure 4. Lickert scale questions to evaluate environmental factors

Figure 5 shows the sets of questions designed to evaluate occupant behaviour in controlling blinds and the reasons for such behaviour.

Occupants behaviours evaluation

Do you have blinds on your window?

Yes No

How often do you put the blinds down?

	Never	1	2	3	4	5	6	7	Always
--	-------	---	---	---	---	---	---	---	--------

What is the main reason of putting the blind down?

1		Prevent inside from overheating
2		Prevent inside from glare
3		Both overheating and glare

Please write any further comments in this space regarding the main reason of putting the blind down?

How would you describe glare from sun and sky in your classroom in summer term?

	None	1	2	3	4	5	6	7	Too much
--	------	---	---	---	---	---	---	---	----------

How would you describe glare Artificial light in your classroom in summer term?

	None	1	2	3	4	5	6	7	Too much
--	------	---	---	---	---	---	---	---	----------

Figure 5. Questions to evaluate occupant behaviour in controlling blinds.

Figure 6 shows the sets of questions designed to evaluate occupant control over the internal environment.

Personal control evaluation

How much control do you personally have over the following aspect of your working environment?

		1	2	3	4	5	6	7	
Cooling	No control								Full control
Ventilation	No control								Full control
Lighting	No control								Full control
Noise	No control								Full control

Figure 6. Questions to evaluate occupant control over comfort factors.

3 Analysis:

In this study, occupant behaviour in controlling blinds was studied followed by an examination of the reasons for such operation. The occupants' usage of windows was also monitored. The level of occupant control over lighting comfort was compared with the level of control over other comfort factors in order to understand areas where a compromise between comfort factors occurs and the potential implications for any gap between design and in-use energy performance.

3.1. Factors which impact on occupant behaviour in controlling blinds

The authors studied the occupants' behaviour in controlling the blinds in 20 primary schools during the cooling seasons (i.e. Jun and July) of 2007 and 2008. In this study, out of 140 classrooms, 110 classrooms had blinds. Eleven out of sixteen schools which had blinds participated in this study in both years.

Figure 7 shows the frequency of movement of blinds in the 110 classrooms from 1=Never to 7=Always. As can be seen, the average frequency of closing the blinds in all of these classrooms (except one classroom of one school) was more than 4 and are towards 7=Always.

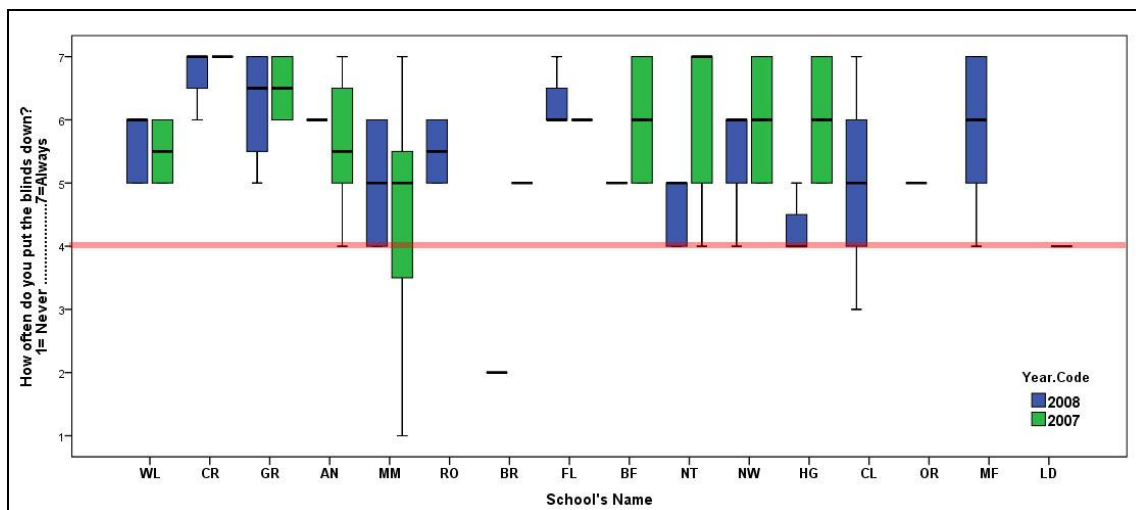

Figure 7. Occupants' behaviour in controlling blind in 110 classrooms.

A Paired sample T test was carried out between the frequency of occupant behaviour in operating blinds in 2007 and 2008. The result shows that there is not a significant difference between occupant behaviour in both year ($p=0.084 > 0.05$).

Questionnaires were distributed among teachers to determine the reasons for putting the blind down. 51% of teachers suggested the reasons were a mixture of preventing glare and overheating while 22% believed use of the blind was only related to glare and 5% linked it only with overheating (Figure 8).

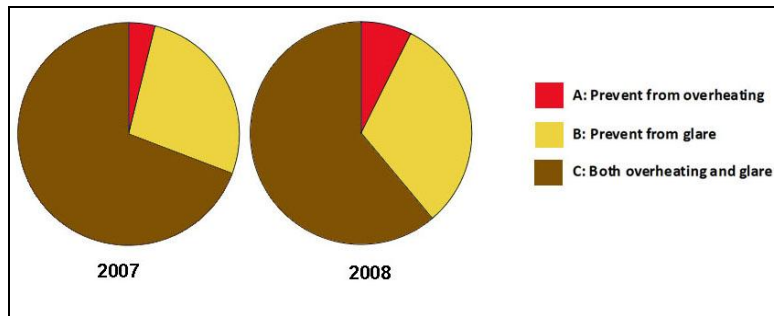

Figure 8. Reasons for putting the blind down in 110 classrooms.

In order to explore the relationship between teachers' perceptions regarding blind operation and both overheating (i.e. thermal comfort) and glare (i.e. visual comfort) as the reasons for putting the blind down, two regression analyses were carried out. The first was between the teachers' perceptions regarding the blind operation and teachers' perceptions regarding thermal comfort inside the classroom and the second was between the teachers' perceptions regarding the blind operation and teachers' perceptions regarding experiencing glare inside the classroom. The results show that there is a significant relationship between the frequency of putting a blind down and both overheating ($n=110$, $p=0.003 < 0.05$, $R^2=0.07$) and experiencing glare ($n=110$, $p=0 < 0.05$, $R^2=0.14$). According to the above regression analyses, experiencing overheating and glare explains 7.5% and 13% of occurrences of putting the blind down respectively.

According to the teachers of these schools, as well as overheating and glare, distractions from outside, particularly where classrooms are located on the ground floor, were also a reason for operating the blinds. Table 2 summarises some comments from the teachers from various schools explaining the reasons for blind operation.

Table 2. Reasons for blind operation according into the interviews.

Primary schools	Teachers' comments
Norwood Green	'Glare from sun on interactive white board decrease productivity, Ceiling ventilation system (Skylight) causes glare on IWB'.
Hungerford	'Cannot see the Interactive White Board. Too much glare, Too much sun light and having to have curtain all the time. Mostly the class dull'
Grove Road	'Much better in a classroom with overhead blind. During smart board work during specific times of the day, there is too much natural light to have it. (Blind down) Completely dark and optimal viewing'.
Feltham	'Can not see IWB'.
Cranford	'Light shines through the blinds making it very hot and very difficult to see the board.'
Berkeley	The reason that I put the blind down is to stop parents / children peering into the classroom'.

These results suggest the three main reasons for putting blinds down are overheating, glare and distractions from outside. These findings concur with those from previous research which focused on office buildings (Inoue et al., 1988; Lindsay and Littlefair, 1992; Reinhart, 2004; Inkarojrit, 2005; Sutter et al., 2006; Sutter Y, 2006; Lindelöf and Morel, 2006; Inkarojrit, 2008; Foster and Oreszczyn, 2011).

Putting the blinds down has some consequences on the electricity consumption in schools as this encourages the occupants to keep the artificial lights on most of the time in order to provide sufficient light levels on their working plane. Images in Figure 9 were taken during a break in two of the above schools. As can be seen, during the study session the blinds had been put down and the artificial light are on.



Figure 9. Implications of putting the blinds down in classrooms on the use of artificial light.
 [(Left: CR primary school, Right: SG primary school)] (Taken by A. Montazami)

The level of glare from artificial light and natural light was also compared in Figure 10. The results suggest that, according to the teachers' perception, occupants mainly suffer glare from natural light rather than artificial light.

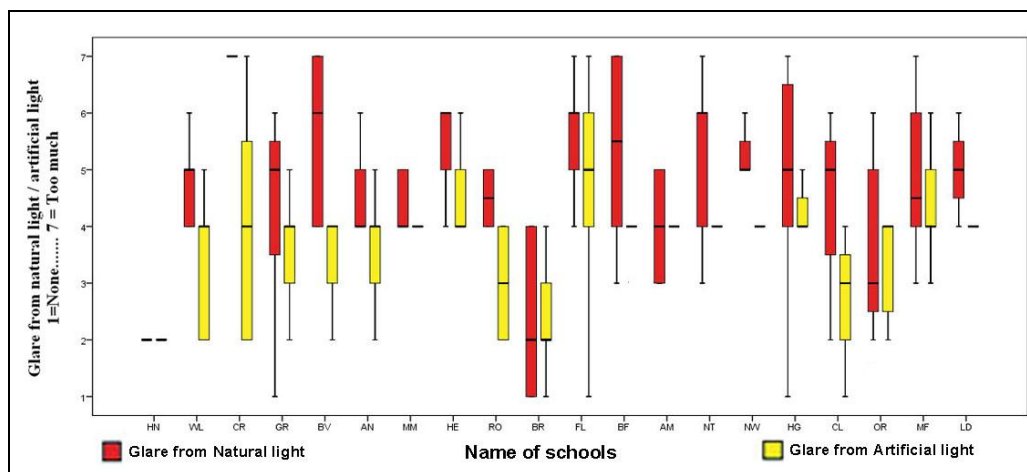

Figure 10. Glare problem as the results of natural and artificial light

The glare problem in classrooms is sometimes related to that which appears on the whiteboard or computer screen.

3.2. Occupant behaviour in controlling blinds in schools constructed in different eras

In order to understand how school design has an impact on occupant behaviour in controlling blinds, an ANOVA T-test was carried out between the teachers' behaviour in controlling blinds in the schools constructed in four different eras; Victorian, open-air, post-war and post- energy crisis. All of these schools are selected from the ones which are naturally ventilated. The results show that there is a significant difference between the occupants behaviour in controlling blinds in these 4 groups schools ($p= 0.045 < 0.05$). As can be seen in Figure 11, although the frequency of putting the blinds down in all four groups is more than 4 and has a tendency to 7=Always, there is a degree of difference between them. The tendency of putting the blind down in post energy crisis schools is approximately 5 with the standard deviation of 2, while the tendency of putting the blind in Victorian, open air and post war schools is approximately 6 with the standard deviation of 1. One likely reason for such difference is due to the window areas in Victorian, open-air and post- war schools being significantly larger in comparison with schools constructed after the energy crisis in the 1970s.

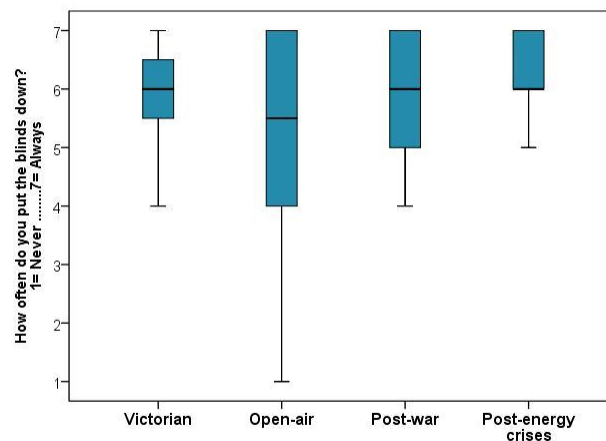

Figure 11: Occupants' behaviour in controlling blind in four groups of schools.

Victorian schools built from 1837 to 1901 have large sash windows which extend to the high ceiling (Robson, 1979). Open air schools constructed in the early part of the 20th Century (1900 – 1939), had large windows due to concerns over the spread of tuberculosis (Wilmor and Saul, 1998), In Post-war schools, constructed after World War II, large windows were employed because natural light was regarded as the main source of illumination. Indeed, guidelines created in 1945 recommended 2% day light factors with the possibility of increasing this to 5% (Stillman, 1994). In contrast, schools constructed after the energy crisis of the 1970s placed greater emphasis on reducing window size as a means of controlling heat loss (Edward, 2010).

3.3. Occupant behaviour in the usage of classroom windows

Based on the authors' observation of 20 schools that were conducted in 2005, 2007 and 2008 internal surfaces of classrooms (walls and windows) are used to display students' work and educational materials. These occupant behaviours (both teacher and students) have a negative impact on the internal environment (i.e. visual and thermal comfort). According to the study carried out by Montazami et al (2012) there is a relationship between occupant behaviour on the usage of classroom walls and the level of overheating in UK schools classrooms. As can be seen from Figures 12, a large area of the windows is covered with students' works which means teachers keep artificial lights on most of the time to compensate for the low level of natural light.



Figure 12. Classroom windows are covered with the student work and artificial lights are on.

(H.O Primary School) (Taken by A. Montazami)

It should be noted that in some cases teachers put the students' work on the window consciously. This is one of the teacher's quotes in this regard 'Although this classroom doesn't have any blinds the windows are covered with students work to prevent glare'.

Figure 13 shows windows of 9 classrooms. As can be seen, windows are covered with students' work which again has a negative impact on internal light levels.

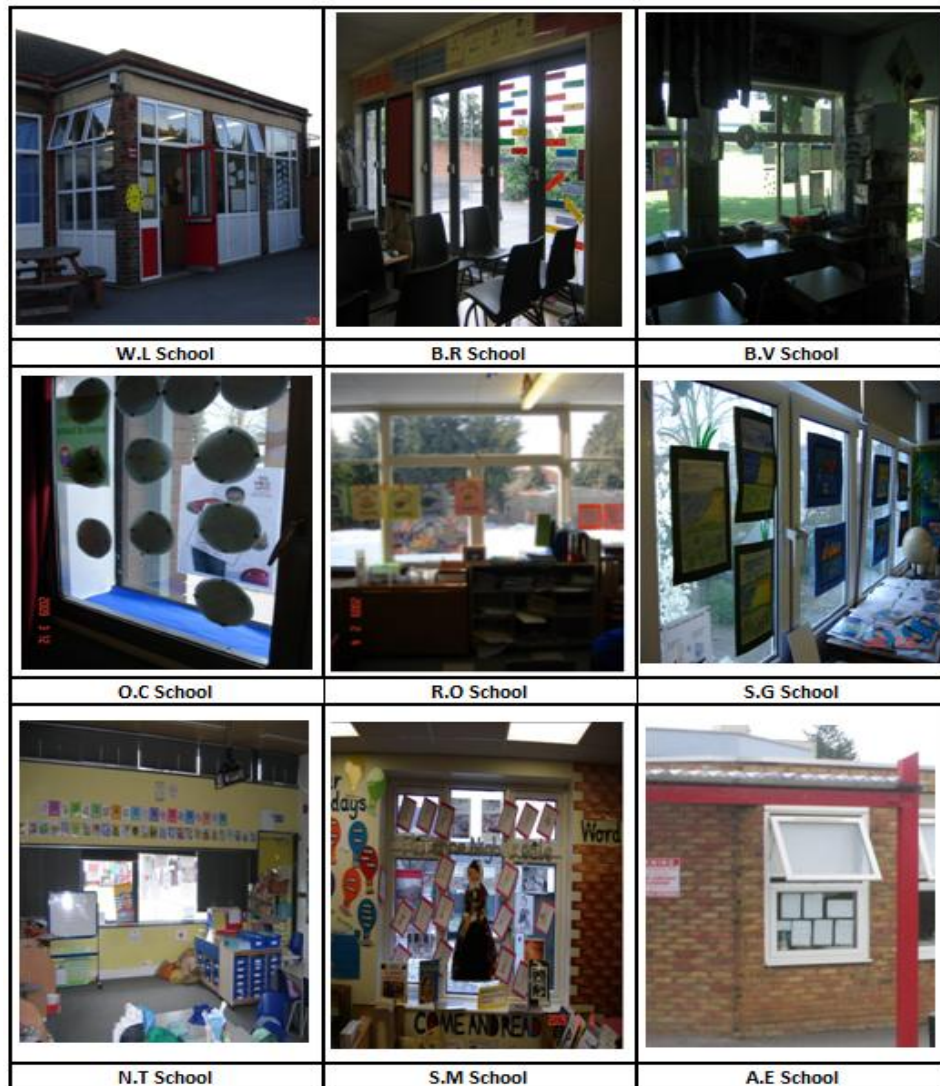

Figure 13. Classroom windows covered with the students works (Taken by A. Montazami).

3.4. Comparing the level of control over lighting comfort to other comfort factors.

According to Nicol et al. (2012), the adaptive approach to comfort is based on the Adaptive Principle whereby ‘if a change occurs such as to produce discomfort, people react in ways which tend to restore their comfort’. Indeed, Bauman (1999) suggests that by giving occupants individual control over the environmental conditions in their workplaces, and the opportunity to adapt, designers and facility managers can help increase worker satisfaction and productivity.

In this study, teachers’ perceptions regarding thermal comfort, lighting comfort (with sources of natural and artificial light), acoustic comfort (with noise sources both outside and inside of school) and also the level of control over these comfort factors were explored on the likert scale. The internal environment was questioned through likert scale of 1= Uncomfortable-Hot/Noisy/Light dissatisfaction/ Stuffy and 7=Comfortable-Cool/ Quiet/ Light satisfaction / Freshness. The level of control was also questioned through likert scale of 1=No Control and 7= Full control.

Regression analysis was carried out between the perception of teachers over the level of control and the quality of the internal environment (Table 3). As can be seen there is a significant relationship between the levels of control and the quality of the internal environment.

Table 3. The relation between internal environment and the level of comfort

Control levels vs Internal environment	Thermal comfort	Noise from outside	Overall lighting	Air quality
	Uncomfortable (1)...Comfortable(7)	Noisy (1)...Quiet(7)	Unsatisfactory(1)...Satisfactory(7)	Stuffy (1)...Fresh(7)
	Summer	(Source : Outside and inside school)	(Source: Natural and artificial light)	
Cooling control	P<0.05 (Significantly related)			
Noise Control		P<0.05 (Significantly related)		
Lighting control			P<0.05 (Significantly related)	
Ventilation Control				P<0.05 (Significantly related)

Figure 14 shows the levels of control and corresponding quality of the internal environment. As can be seen, the level of control over lighting comfort is higher than control over other comfort factors and also the occupants' satisfaction over lighting comfort is also higher (highlighted in red).

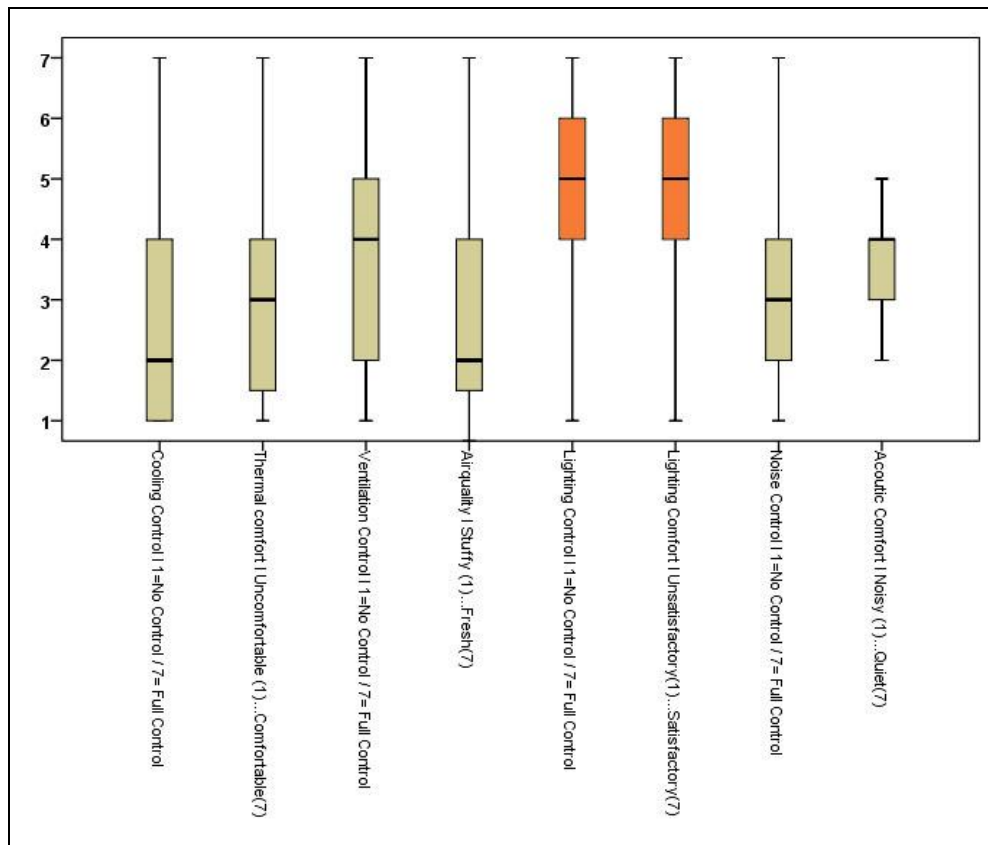

Figure 14: Level of control vs internal environment

It can be argued that although there is a higher level of control over lighting comfort and a higher perception about the quality of visual comfort, there are some hidden implications as the result of high level of control and poor window design that should be considered. For example, occupant behaviour in putting the blind down and the resulting lower level of natural light has a negative impact on students' health/performance and a higher level of energy consumption (i.e. using more artificial light) with a concomitant rise in carbon footprint and energy costs.

Blinds are one of the components that should be considered carefully during window design. For example, in classrooms that face east and west, vertical blinds should be considered while in classrooms facing south, horizontal blinds, light shelf or overhanging window reveals are likely to be more effective. In addition, the occupants' behaviour in controlling blinds should form part of this procedure. Having horizontal blinds on east and west facing elevations or on classroom windows that face onto busy areas of a school means teachers are likely to keep them down most of the time (in order to prevent glare, overheating and also distraction) with the consequences outlined above.

4 Discussions:

This research set out to understand how teachers use devices such as blinds to control their internal environment, the potential implications of their use on light levels and consequently their likely role in the gap between predicated and actual electricity consumption.

Results suggest that the frequency of putting blinds down in 99% of classrooms was towards 'always' according to the teachers' perceptions. This study also illustrates that there is a higher tendency for putting the blinds down in Victorian, open-air, post-war schools in comparison to post-oil crisis schools due to the likelihood of the former having larger windows.

According to this study, the main reasons for such behavior were preventing glare, reducing overheating and limiting distractions from outside. This study also illustrates that school teachers use the classroom window as a place to display students' work sometimes as a conscious decision to reduce the glare, overheating and also distractions from outside.

This study highlights that the two likely implications of putting the blinds down are a lower level of natural light inside the classrooms, which can have a negative impact on students' health and performance, and an increase in the level of electricity consumption through the use of artificial light which has a negative impact on a school's carbon footprint and costs.

Results also confirm that there is a relationship between the level of control over the internal environment and the teachers' satisfaction about the internal environment. The provision of opportunities for occupants to control their surrounding environment are clearly important. However, it is essential that occupants are also aware of the implications of their actions. It is also critical that designers understand fully the motivations of occupants to control their internal environment. The unintended consequences of operating devices such as blinds that were not envisaged during the design stage, particularly the potential knock-on effects on electricity consumption, are likely to play a role in the gap between design intent and in-use energy consumption. Therefore, a

systematic approach to understanding occupant requirements and behaviour, feeding back details of actual occupant behaviour and educating occupants in the implications of their actions should form part of the design process, particularly if we are to ensure effective, energy efficient teaching spaces that function as intended are delivered.

5 Conclusion:

This study highlights the need to not only understand the multi dimensional role of windows and blinds in controlling the internal environment in UK primary schools but also the implications of occupant behaviour on delivering required comfort conditions. .

In developing such an understanding the often conflicting comfort requirement need to be considered. For example, the provision of a good view to the outside without it being distracting for students; the provision of sufficient light while preventing glare; and the use of windows as a source of heat gain during winter but without introducing overheating during summer.

In future, the school design process should incorporate the occupants' needs and behaviour as an element in the design process to provide a more effective level of control. Educating occupants on the implications of their choices should form part of this process.

The proposed approach will help building designers reduce the gap between predicted and actual electricity energy consumption, particularly where this is associated with the use of artificial lighting. It will also help ensure effective and efficient teaching and learning spaces are actually delivered.

Acknowledgment:

The authors would like to express their thanks to the head teachers for their permission and support to use their schools as a case study. Special thanks also to the teachers that participated in this research.

References:

- Barbara B, Kawulich., 2005, Participant Observation as a Data Collection Method. FOS (Forum of qualitative social research) 2005: 6: No 2
- Barnitt, H. 2003, Lighting for the Future, Building Services Journal: The magazine for the CIBSE, 25, 1, 38-39.
- Bordass B, Cohen R, Field J., 2004, Energy performance of non-domestic buildings – closing the credibility gap. In: International conference on improving energy efficiency in commercial buildings. Frankfurt, Germany.

- Bordass B, Cohen R, Standeven M, Leaman A., 2001, Assessing building performance in use 3: energy performance of probe buildings. *Build Res Inform*;29(2):114–28.
- Building Bulletin (BB) 90, 2003, A design guide: Lighting design for schools. Department for Education and Skills (DfES). London
- Carbon trust, 2012, Schools Learning to improve energy efficiency Sector , www.carbontrust.com, UK
- CHPS-The Collaborative for high performance school, "Lighting comfort" (n.d.), Available from : <http://www.chps.net/> (Accessed 2006).
- CIBSE KS6, 2006, Comfort. Chartered Institution of Building Services Engineers. London.
- CIBSE TM 37, 2006. Design for improved solar shading control. Chartered Institution of Building Services Engineers. London
- Demanuele C, Tweddell T, Davies M., 2010, Bridging the gap between predicted and actual energy performance in schools. World renewable energy congress XI. 25–30 September, Abu Dhabi, UAE.
- Demanuele, C., Tweddell, T. & Davies, M., 2010. Bridging the gap between predicted and actual energy performance in schools. , (September), pp.1–6.
- Dunn, R., Kiimsky, J., Murray, J., Quimm, P. 1985. Light up their lives: A review of research on the effects of lighting on children achievement and behaviour. *The Reading Teacher* (39) 19, pp. 863-869.
- Dutton S, Shao L., 2010. Window opening behaviour in a naturally ventilated school. In: Presented at the IBPSA conference
- Edwards, B. 2010, *Rough guide to sustainability: a design primer*, London: RIBA Publishing
- Foster M, Oreszczyn T., 2001. Occupant control of passive systems: the use of venetian blinds. *Building and Environment* 2001;36:149-55.
- Fred S. Bauman, P.E., 1999. Giving Occupants What They Want: Guidelines for Implementing Personal Environmental Control in Your Building, Presented at World Workplace 99, October 3-5, 1999, Los Angeles, CA, and published in the Proceedings. [Online] Available at: http://www.cbe.berkeley.edu/research/pdf_files/FBau_WorldWk1999.pdf [Accessed Sept 2013].
- Global Action Plan. UK Schools Carbon Footprint Scoping Study. Stockholm Environment Institute; 2006. p. 1–76.
- HM Government. Climate Change Act 2008 (c. 27). 2008.

- Inkarojrit V, 2008. Monitoring and modelling of manually-controlled Venetian blinds in private offices: a pilot study. *Journal of Building Performance Simulation* 2008;1:75-89
- Inkarojrit V., 2005. Balancing comfort: occupants' control of window blinds in
- Inoue T, Kawase T, Ibamoto T, Takakusa S, Matsuo Y. 1988, The development of an optimal control system for window shading devices based on investigations
- Kawulich, B., 2005. Participant Observation as a Data Collection Method. *FOS (Forum of qualitative social research)* 2005; 6: No 2; Available from <http://www.qualitative-research.net/> (Accessed 2013)
- Lindelöf D, Morel N., 2006. A field investigation of the intermediate light switching by users. *Energy and Buildings* 2006; 38:790-801
- Lindsay C, Littlefair P., 1992. Occupant use of venetian blinds in offices, vol. 233; 1992. p. 92. PD. in office buildings. *ASHRAE Transactions*; 94:1034-49.
- Menezes, A.C, 2012. Predicted vs. actual energy performance of non-domestic buildings: Using post-occupancy evaluation data to reduce the performance gap. *Applied Energy*, 97, pp.355–364. Available at: <http://linkinghub.elsevier.com/retrieve/pii/S0306261911007811> [Accessed November 9, 2013].
- Montazami, A., Nicol, F. and Gaterell. M (2014), The effect of thermal mass on thermal performance in UK primary school classrooms, *Energy and Buildings*, (Under review)
- Montazami, A., and Nicol, F. (2013) 'overheating in schools: comparing existing and new guidelines'. *Journal of Building Research and Information*, 41, 3, 317-331.
- Nicol, JF, Humphreys MA and Roaf, SC, (2012) *Adaptive thermal comfort: principles and practice*, London Earthscan/Routledge March 2012
- Ott, J., 1976, Influence of fluorescent lights on hyperactivity and learning disabilities. *Journal of Learning Disabilities*, 9(7), 22-27.
private offices. Citeseer
- Stillman CG, Castle Cleary R. *The modern school*, 75. London: The Architectural Press; 1949.
- Reinhart CF., 2004. Lightswitch-2002: a model for manual and automated control of electric lighting and blinds. *Solar Energy*; 77:15-28.
- Robson, E.R., 1874. *Schools Architecture*, Murray, (Reprinted 1979): Leicester University Press.
- Sutter Y, Dumortier D, Fontoynt M., 2006. The use of shading systems in VDU task offices: a pilot study. *Energy and Buildings*; 38:780-9.

- Taylor, A., Gousie, G., 1988, The Ecology of Learning Environments for Children. Educational facility planner, 26 (4). <http://www.coe.uga.edu/sdpl/researchabstracts/visual.html>.
- Usable Buildings Trust (UBT). <<http://www.usablebuildings.co.uk/Pages/UBProbePublications1.html>> [accessed 17.11.11].
- Walden.R, 2008. Building school for the future - Design Proposals from Architectural Psychology, Hogrefe and Huber. Germany.
- Wilmot, F. and Saul, P., (1998) Breath of fresh air- Birmingham's Open-air Schools 1911- 1970, Phillimore; 1998.

Do the constants used in adaptive comfort algorithms reflect the observed responses of children in junior school classrooms?

Despoina Teli^{1*}, Patrick A.B. James¹, Mark F. Jentsch²

¹Sustainable Energy Research Group, Faculty of Engineering and the Environment, University of Southampton, Southampton SO17 1BJ, United Kingdom

²Urban Energy Systems, Bauhaus-Universität Weimar, 99423 Weimar, Germany

*Corresponding author. Tel: +44 (0)2380592174, E-mail: D.Teli@soton.ac.uk

Abstract

This paper compares the values used for the Griffiths constant ($G=0.5$) and the running mean constant ($\alpha=0.8$) in adaptive comfort algorithms with the values calculated from thermal comfort field surveys in two naturally ventilated junior schools in Southampton, UK. The surveys were conducted outside the heating season in 2011 and 2012 respectively, including both questionnaire surveys and environmental monitoring. A total of 2693 pupil responses were used for this analysis. The data was examined in two steps: first, each survey set; obtained over a 1-day visit to the school; was examined in order to derive the relationship between indoor temperature change and comfort vote with minimum impact of adaptation. Second, the dataset was investigated for the prolonged periods of the surveys, in relation to weather experienced by the pupils in order to estimate their time for adaptation to outdoor temperature changes. The paper gives an insight into the response of pupils to internal and external temperature changes, immediate and over prolonged periods, in comparison to adults.

Key words: School buildings, Griffiths constant, adaptive comfort, Field surveys, children.

1. Introduction

The adaptive thermal comfort model is based on extensive fieldwork mainly in office environments, which led to the understanding of the adaptive relationship between climate and comfort (Nicol et al., 2012). Recent research by the authors investigated pupils' thermal sensation in school classrooms and found discrepancies between children's thermal responses and the predictions using adaptive comfort algorithms which were based on surveys with adults (Teli et al., 2012, Teli et al., 2013). The differences found cover a range of parameters, such as thermal sensation, feeling of overall comfort and tiredness, long-term and immediate adaptive behaviour and interpersonal differences (Table 1). Furthermore, research showed that the existing overheating guidelines found in the UK school Building Bulletins 87 and 101 (DfES, 2003, DfES, 2006) and the new guidelines proposed by the Department for Education (Johnston and Partners, 2012) do not reflect teachers' views on pupils' comfort (Montazami and Nicol, 2013). The above is important information since uncomfortable classroom conditions have been found to influence the health and schoolwork performance of children (Mendell and Heath, 2005, Wargocki and Wyon, 2007). It suggests that child-specific thermal comfort criteria are required, based on adaptive comfort modelling for children.

Table 1. Summary of results from authors' surveys with school children

Factor	Survey results
Comfort temperature	Children's comfort temperature was observed to be approximately 2°C lower than predicted using the EN 15251 adaptive model
Feeling of overall comfort and tiredness	The pupils' perceived overall comfort was more associated with their feeling of tiredness rather than with their thermal sensation
Immediate adaptive behaviour	Weak response in children (based on clothing changes over the same day)
Long-term adaptation	Similar to adults', clothing level is decreasing when indoor temperatures increase
Interpersonal differences	Stronger in pupils than adults [mean pupil standard deviation S.D.=1.5, against adult mean S.D.=1.07 (Humphreys et al., 2007)]

For the derivation of the currently used adaptive equations for thermal comfort two constants are used, one expressing the linear relationship between comfort vote and operative temperature, called the 'Griffiths constant' (G) (Humphreys et al., 2007), and one reflecting the time it takes for people to adapt to outdoor temperature changes, the 'running mean constant' (α) (McCartney and Nicol, 2002). The values used for these constants were derived from the analysis of field data mainly in offices with adult subjects. This paper is revisiting these values for the case of children in naturally ventilated school classrooms. This analysis expands on the discrepancies found between the pupils' comfort temperatures and those calculated using the adaptive comfort model. In order to ensure more representative comfort predictions in school classrooms it is necessary to identify the source of these discrepancies and investigate their relation to adaptive comfort model components, such as the constants' G ' and ' α '.

There are two adaptive comfort algorithms which have been developed to relate the occupant comfort temperature to the outdoor climate. These are the European adaptive algorithm based on the SCATs database (McCartney and Nicol, 2002), used in the European standard EN 15251 (CEN, 2007), and the worldwide ASHRAE adaptive algorithm (De Dear et al., 1997), used in ASHRAE standard 55 (ASHRAE, 2010). The way the 'neutral' or 'comfort' temperature is estimated differs between the two adaptive comfort projects, mainly due to different sample sizes (de Dear et al., 2013). The ASHRAE database allowed for statistically significant regression analysis at the individual building level, whilst in the case of the SCATs database the Griffiths method has been used, which can address cases of small samples of comfort votes. In this paper, the method used in the SCATs database has been applied as it was considered to be more appropriate for the school survey sample sizes and for consistency with the European EN 15251 algorithm.

The paper investigates whether G ' and ' α ' agree with pupils' responses from thermal comfort surveys in two naturally ventilated junior schools. This will help to understand the thermal response of pupils to indoor temperature changes through 'day-survey' analysis for the estimation of ' G ', assuming that no or minimal

adaptation has occurred. Furthermore, the paper looks at pupils' thermal response rate to the outdoor climate, through exploration of the running mean constant ' α '.

1.1. Griffiths constant

The Griffiths constant represents the relationship between thermal sensation and temperature, with the assumption that no adaptation has occurred (Nicol and Humphreys, 2010). It is the regression coefficient of comfort vote to operative temperature, when only the operative temperature is assumed to be changing and therefore reflects people's sensitivity to temperature changes. The estimation of this regression coefficient would require conditions which cannot be achieved in field studies as it is not possible to isolate the operative temperature as the only parameter influencing occupant thermal sensation. Therefore an optimum value for this coefficient has been estimated (' G '=0.5) (Humphreys et al., 2007), using data from the extensive SCATs (McCartney and Nicol, 2002) and ASHRAE (De Dear et al., 1997) databases. Further analysis was conducted in 2010, using a 'day-survey' methodology (Humphreys et al., 2010). The same method of estimation is used in this paper.

For setting up the adaptive comfort algorithm, the Griffiths constant ' G ' is used in equation (1), which relates people's comfort temperature T_{comf} to the operative temperature T_{op} and their reported thermal sensation (Humphreys et al., 2007). The subjects' thermal sensation is expressed in the form of their vote (TSV: Thermal Sensation Vote) on a 7-point thermal sensation scale, such as the ASHRAE scale (hot, warm, slightly warm, neutral, slightly cool, cool, and cold). The calculated comfort temperatures are then used in the development of the adaptive relationship between the comfort temperature and the outdoor climate.

$$T_{\text{comf}} = T_{\text{op}} - \text{TSV}/G \quad (1)$$

1.2. Running mean constant ' α '

The main principle of adaptive thermal comfort is to relate the comfort temperature to the outdoor climate. Initially, this relationship was expressed using the monthly mean of the outdoor temperature (Humphreys, 1978) but this approach did not take into account people's thermal experience, which suggests that recent climatic conditions are more influential than earlier experiences (CIBSE, 2006). Therefore, the running mean T_{rm} of outdoor temperatures was chosen as a suitable outdoor climate index, weighted according to distance in the past, based on the adaptive comfort approach's assumption that comfort temperature is influenced more by recent experiences (Olesen, 2007). T_{rm} is calculated using equation (2) (Nicol et al., 2012).

$$T_{\text{rm}} = (1-\alpha) \cdot \{T_{\text{ed-1}} + \alpha \cdot T_{\text{ed-2}} + \alpha^2 \cdot T_{\text{ed-3}} \dots\} \quad (2)$$

Where:

- T_{rm} = Exponentially weighted running mean of the outdoor temperature
- $T_{\text{ed-1}}$ = Daily mean outdoor temperature for the previous day
- $T_{\text{ed-2}, \dots}$ = Daily mean outdoor temperature for the day before and so forth

The running mean constant α can take values between 0 and 1. It is essentially a time constant which "defines the quickening response of the running mean to changes in the outside temperature" (McCartney and Nicol, 2002). Its value, $\alpha=0.8$, was estimated using survey data and corresponds to the strongest correlation between the

respondents' calculated comfort temperature [equation (1)] and the outdoor running mean (Humphreys et al., 2007). Feeding into the equation which relates the comfort temperature to the outdoor temperature, 'α' is an indicator of the time it takes for people to adapt to outdoor climate variations.

The half-life of an exponentially weighted running mean temperature has been defined and can be calculated using equation (3) (Nicol and Humphreys, 2010). For α=0.8 the equation gives λ=3.5, which means that it takes about a week for the occupants to adapt to a step-change of the mean outdoor temperature.

$$\lambda=0.69/(1-\alpha) \quad (3)$$

Humphreys et al argued that there is potentially a link between the value of α and the building's thermal inertia, suggesting that buildings with different thermal capacity may have different values of 'α' (Humphreys et al., 2013). This will be investigated here, using the two case study school buildings, which differ mainly in their thermal mass.

In summary, the values of both constants 'G' and 'α' were determined using adults' responses from the two adaptive comfort databases. Given the different thermal perception of children found from pupil surveys (Teli et al., 2012, Teli et al., 2013), these values need to be compared against children's responses.

2. Methodology

The data used in this paper was collected during thermal comfort surveys in two naturally ventilated schools in Southampton, a light-weight and a Victorian high thermal mass building. The surveys included questionnaires tailored for children and measurements of the key environmental parameters during the surveys.

2.1. Case study schools

The case study junior school buildings are of different typologies, as shown in exemplar sketches in Figure 1. Building A is a typical example of a light-weight 1970s school in the UK, with steel frame construction and pre-fabricated concrete panels. It was constructed in 1978. The school has 8 classrooms. Around 240 pupils aged 7-11 were enrolled in Years 3 to 6 in the year of the survey. The surveys were undertaken in all 8 classrooms outside the heating season, from April to July 2011. School building B was surveyed one year later, from April to July 2012. This building was constructed in 1884, following typical Victorian school construction methods. It has around 400 enrolled pupils aged 5-11 (2012 data). The surveys took place in all 11 classrooms of the school.

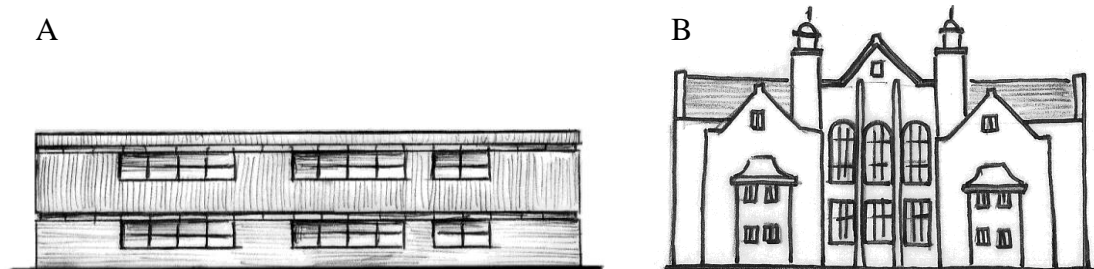

Figure 1. Sketch elevations of the types of school buildings surveyed, left: A. post-war light-weight building, right: B. Victorian heavy-weight building

The surveys in both schools were scheduled to take place approximately every two weeks. Each classroom of school A was surveyed 6 times and, therefore, 48 surveys were carried out in total. In school B, 69 surveys were carried out. An average of 26 pupils responded to the questionnaire in each survey (Teli, 2013).

2.2. Thermal comfort surveys

For reasons of consistency, the same methods and equipment were used in both school studies. The survey procedure, questionnaire and data processing details have been described in previous papers, based on the first school survey in 2011. Therefore, these are only summarised here:

- A questionnaire adapted for children was used, based on teachers' feedback (Teli et al., 2012). The questionnaire included questions about the respondent's thermal sensation vote (TSV) and thermal preference vote (TPV), the feelings of overall comfort and tiredness, whether the respondent was wearing a jumper (pullover) and the activity undertaken prior to the questionnaire.
- The responses were checked for inconsistency. Responses with significantly conflicting votes (thermal sensation in clear contrast to thermal preference) were excluded from the analysis (Teli et al., 2012, Teli et al., 2013).
- Based on the small number of missing responses and inconsistent cases, the questionnaire can be considered as appropriate for junior school children (Teli et al., 2013). However, it should be highlighted that more research is required in order to develop a holistic methodology for surveying children.
- Environmental parameters (air speed, radiant temperature, air temperature, relative humidity and CO₂ concentration) were measured during the surveys, following the standards of ISO 7726 "Ergonomics of the thermal environment-Instruments for measuring physical quantities" (ISO, 2001).

3. Results

For the analysis presented in this paper, the pupils' thermal sensation votes (TSV) and the operative temperatures measured during the surveys (T_{op}) were used.

3.1. Relationship No 1: Comfort vote and operative temperature

The estimation of the regression coefficient (constant 'G') follows the 'day-survey' method of Humphreys et al (Humphreys et al., 2013). This includes:

- Calculation of the variables $dTSV$ and dT_{op} for each response on a single day (day survey), where $dTSV$ is the difference of the subjective thermal sensation vote (TSV) and the mean thermal sensation vote for the 'day-survey' ($TSV_{(day\ mean)}$) and dT_{op} is the difference of the operative temperature during the survey (T_{op}) and the mean operative temperature on that day ($T_{op(day\ mean)}$).
- Regression analysis of $dTSV$ on dT_{op} of all the 'day-surveys'.

This process leads to a weighted average of the regression coefficient for all the 'day-surveys', which can provide a more reliable statistic than the analysis of small 'day-survey samples' (Humphreys et al., 2013). Following this method, for each day visit to the schools, the $dTSV$ and dT_{op} were calculated. Regression analysis was conducted in the SPSS statistical package, for both schools, combined and separately. A total of 26 day surveys were used. The calculated regression coefficients are

statistically significant ($p < 0.001$). The regression line for the entire dataset with the 95% confidence intervals can be seen in Figure 2. The narrow intervals suggest that the regression coefficient can be considered reliable.

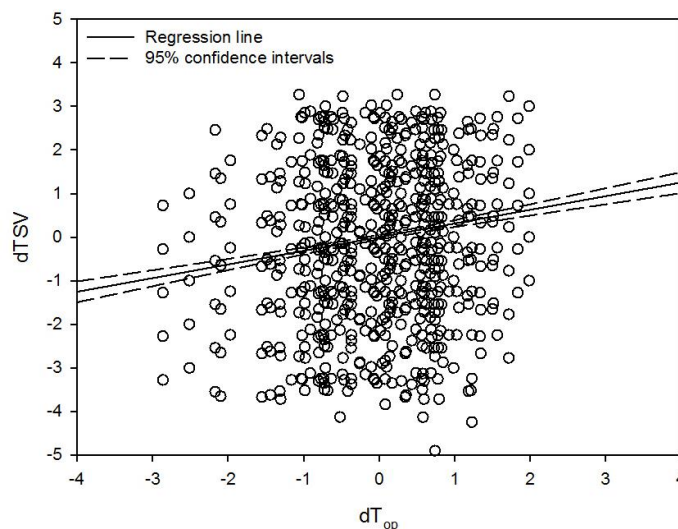

Figure 2. Difference of subjective thermal sensation vote and mean thermal sensation vote for the ‘day-surveys’ (dT_{SV}) against the difference of the operative temperature during the surveys and the mean operative temperature on the ‘day-surveys’ (dT_{op})

The regression coefficients are presented in Table 2, in comparison to the SCATs and ASHRAE regression coefficients for the naturally ventilated buildings (NV) of the databases only, as previously estimated (Humphreys et al., 2010). The value of the regression coefficient for both schools is 0.313 with a standard error of 0.030, which is very similar to the values from the SCATs and ASHRAE databases. The variance of the operative temperature is also similarly low.

Table 2. Regression coefficients for the naturally ventilated buildings in the SCATs and ASHRAE databases and the two schools, separately and combined (SPSS results)

Database	No of observations	Variance of dT _{op}	Regression coefficient	Standard error of coefficient
SCATs (NV) (Humphreys et al., 2010)	1440	0.744	0.361	0.030
ASHRAE (NV) (Humphreys et al., 2010)	2585	0.555	0.308	0.024
Both schools combined	2693	0.842	0.313	0.030
Light-weight school	1211	0.769	0.198	0.045
Heavy-weight school	1482	0.903	0.392	0.040

The value of Griffiths constant $G=0.5$ was derived from the values of the SCATs and ASHRAE databases, following correction to account for errors in the predictor variable (operative temperature) due to its low variance (Humphreys et al., 2010). The

correction of the regression coefficient can be assumed to apply to the schools since the variance of the operative temperature is similarly low and, therefore, the comparison here regards the calculated regression coefficients of Table 2 only.

Looking at the results of each school separately, the light-weight school appears to have a lower variance of the operative temperature, which would not be expected based on the greater temperature fluctuation these buildings normally experience. The difference is probably related to the complex layout of the heavy-weight school, with classrooms on several different orientations (NW, NE, SE, SW) and levels (ground and first floor classrooms). The surveys were conducted in different classrooms over a single day. In the light-weight school, the conditions were more uniform in this respect, as the classrooms face only two orientations, NE and SE. Furthermore, in the light-weight school the day-surveys were conducted on one level (ground or first floor), minimising the impact of that parameter on temperature fluctuations. It is evident that the distinction between building construction type and form is very important in such analyses.

3.2. Relationship No 2: Comfort temperature and outdoor climate

The comfort temperature was calculated for every thermal sensation vote using equation (1) and a value of $G=0.5$, based on the previous analysis. The running mean of the outdoor temperatures was calculated using equation (2). The outdoor daily mean temperatures were derived from hourly data from the National Oceanographic Centre in Southampton (NOCS), which is located approximately 3km away from both schools. The running mean of the outdoor temperature was calculated for different values of ' α ', ranging from 0.33 to 0.99, which correspond to different durations of adaptation, as can be seen in Table 3. This is based on the values used in the analysis of the SCATs database, as highlighted by Figure 3.

Table 3. Relationship between adaptation time and ' α '

Value of ' α '	Approximate duration of adaptation to a step change of the mean outdoor temperature (in days)
0.33	2 days
0.45	3 days
0.70	5 days
0.80	7 days
0.90	14 days
0.96	35 days
0.99	140 days

Figure 4 shows the correlation coefficients of the calculated comfort temperatures from the pupils' thermal sensation votes with the exponentially weighted outdoor running mean. All values were significant ($p<0.001$). As can be seen in Figure 4, using the data from both schools combined, the correlation coefficients generally agree with the UK trend from the SCATs database, except for the big drop for $\alpha=0.99$, which does not appear in the school results (Figure 3). The strongest correlation

occurs for $\alpha=0.8$ and starts to decline smoothly from a value of 0.9, but overall the weighting does not appear to be critical for the correlation. It appears that a value of $\alpha=0.8$ is appropriate for use in schools, indicating a duration of approximately one week for adaptation to a change in outdoor temperature.

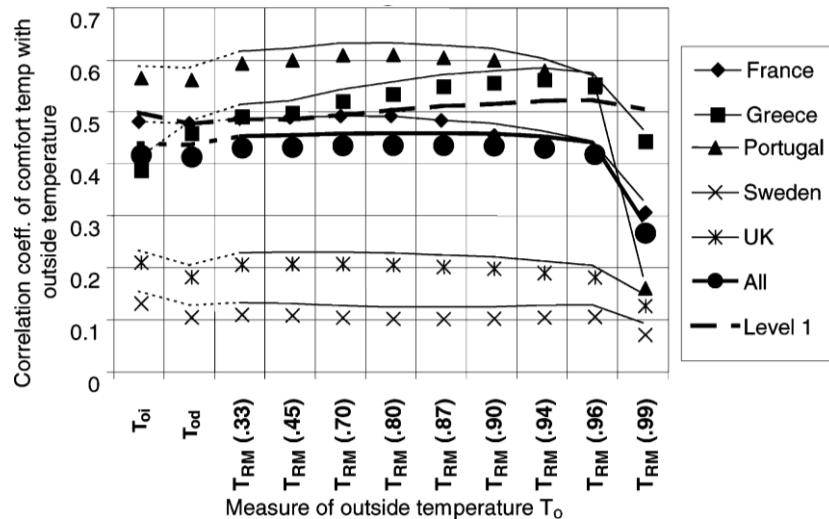

Figure 3. Correlations between comfort temperature and measures of the outdoor temperatures, total and per country, as calculated from the SCATs database (McCartney and Nicol, 2002).

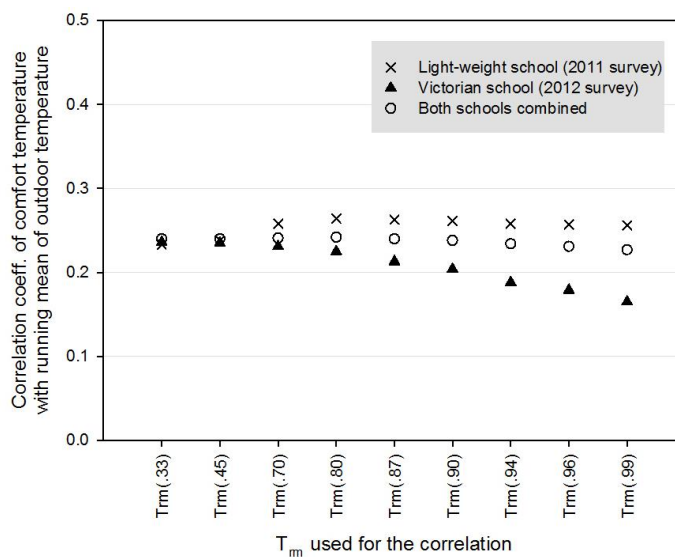

Figure 4. Correlations between comfort temperature and the running mean outdoor temperature for different values of ' α ', as calculated from the two case study schools, separately and combined.

Looking at the school types separately, there is a strong difference. The correlation of the comfort temperature with the outdoor running mean temperature is overall stronger in the light-weight school compared to the heavy-weight school, which can be explained by the quick response of the building fabric of the light-weight school to outdoor temperature variations. The indoor environment that occupants experience is coupled to the outdoor temperature and therefore occupant comfort is strongly affected by the outdoor climate. In contrast, the high thermal mass fabric of the Victorian school isolates the occupants from outdoor temperature variations by creating a more stable indoor thermal environment.

As can be seen in Figure 4, above a value of $\alpha=0.8$ there is almost no change in the correlation coefficient in the case of the light-weight school, whilst in the case of the heavy-weight school there is a clear gradual decrease, starting from a value of $\alpha=0.45$. The flat trend of the correlation in the light-weight school indicates that the weighting of the mean outdoor temperature based on distance from the past is not that critical for the correlation between comfort temperature and outdoor temperature. This suggests that pupils' comfort temperature was similarly influenced by recent and past experiences. In the case of the heavy-weight building, the weighting appears to be important, with recent experiences having a stronger impact on pupils' comfort temperature than past events, probably because the indoor environment is not significantly affected by these events, allowing for past experiences to fade. Overall, the analysis suggests that there may be differences in thermal adaptation due to the thermal properties of the buildings. Comparison of survey data from different construction types would help to understand these issues better.

4. Conclusions

This paper compared the typical values of the constants 'G' and ' α ', used in adaptive comfort algorithms, with values which were derived from thermal comfort surveys in two naturally ventilated junior schools. The regression coefficients used for the estimation of $G=0.5$ in previous studies agree well with the survey results suggesting that this value can be used in the comfort temperature calculation for children, although this needs further validation. Overall, it appears that, assuming no or minimal adaptation has taken place, children's response rate to indoor temperature changes can be considered similar to that of adults.

In terms of the time it takes for pupils to adapt to a step-change of the mean outdoor temperature, it seems that one week is the most likely duration, which corresponds to a value of ' α '=0.8. However, the difference between the correlation coefficients for different values of ' α ' was very small to fully support this finding. The comparison per school construction type highlighted a difference which suggests that the building's thermal properties influence the time it takes for occupants to adapt to outdoor temperature changes.

It should be noted that the use of only two schools in this analysis does not provide a complete assessment for the case of school buildings in general. Furthermore, each pupil only responded once to the questionnaire per 'day-survey'. More responses per 'day-survey' might give a more representative result in terms of thermal response over a day. These limitations suggest that extensive fieldwork in schools is required in order to obtain more reliable data for the estimation and assessment of pupils' comfort in classrooms.

Overall, the constants 'G' and ' α ' appear to be as appropriate for use in school environments as they are for environments with adults [However, the overall need for further work to define the value of ' α ' has been recently highlighted (Humphreys et al., 2013)]. There were differences between the light-weight and heavy-weight school which suggest that buildings' thermal capacity is an important parameter affecting occupants' thermal adaptation.

5. Acknowledgments

The authors would like to deeply thank the teachers and pupils who participated in the surveys.

6. References

- ASHRAE (2010). ANSI/ASHRAE Standard 55- Thermal Environmental Conditions for Human Occupancy. Atlanta: American Society of Heating, Refrigerating and Air-Conditioning Engineers.
- CEN (2007). EN 15251:2007 Indoor environmental input parameters for design and assessment of energy performance of buildings addressing indoor air quality, thermal environment, lighting and acoustics. Brussels: CEN (European Committee for Standardization).
- CIBSE (2006). *Guide A-Environmental design*, London, Chartered Institution of Building Services Engineers.
- de Dear, R. J., Akimoto, T., Arens, E. A., Brager, G., Candido, C., Cheong, K. W. D., Li, B., Nishihara, N., Sekhar, S. C., Tanabe, S., Toftum, J., Zhang, H. & Zhu, Y. (2013). Progress in thermal comfort research over the last twenty years. *Indoor Air*, 23, 442-461.
- De Dear, R. J., Brager, G. S. & Cooper, D. J. (1997). Developing an adaptive model of thermal comfort and preference-Final Report on ASHRAE RP-884. Sydney.
- DfES (2003). Building Bulletin 87. Guidelines for Environmental Design in Schools. UK Department for Education and Skills.
- DfES (2006). Building Bulletin 101. Ventilation of School Buildings. UK Department for Education and Skills.
- Humphreys, M., Rijal, H. B. & Nicol, F. (2010). Examining and developing the adaptive relation between climate and thermal comfort indoors. *Adapting to Change: New Thinking on Comfort, 9-11 April 2010*. Cumberland Lodge, Windsor, UK.
- Humphreys, M. A. (1978). Outdoor temperatures and comfort indoors. *Building Research & Information*, 6, 92 - 105.
- Humphreys, M. A., Nicol, J. F. & Raja, I. A. (2007). Field Studies of Indoor Thermal Comfort and the Progress of the Adaptive Approach. *Advances in Building Energy Research*, 1, 55-88.
- Humphreys, M. A., Rijal, H. B. & Nicol, J. F. (2013). Updating the adaptive relation between climate and comfort indoors; new insights and an extended database. *Building and Environment*, 63, 40-55.
- ISO (2001). EN ISO 7726:2001 Ergonomics of the thermal environment- Instruments for measuring physical quantities. Brussels: International Standardisation Organisation.
- Johnston and Partners. (2012). EFA PSBP Natural Ventilation Strategy. Available: <https://media.education.gov.uk/assets/files/pdf/b/ventilation%20strategy%20190912.pdf>.

- McCartney, K. J. & Nicol, F. (2002). Developing an adaptive control algorithm for Europe. *Energy and Buildings*, 34, 623-635.
- Mendell, M. & Heath, G. (2005). Do indoor pollutants and thermal conditions in schools influence student performance? A critical review of the literature. *Indoor Air 2005. The 10th International Conference on Indoor Air Quality and Climate*. Beijing, China.
- Montazami, A. & Nicol, F. (2013). Overheating in schools: comparing existing and new guidelines. *Building Research & Information*, 41, 317-329.
- Nicol, F., Humphreys, M. & Roaf, S. (2012). *Adaptive thermal comfort: Principles and practice*, London, Routledge.
- Nicol, J. F. & Humphreys, M. A. (2010). Derivation of the adaptive equations for thermal comfort in free-running buildings in European standard EN15251. *Building and Environment*, 45, 11-17.
- NOCS. *Meteorological station. National Oceanographic Centre, Southampton. A collaboration between NOCS & Met Office* [Online]. Available: http://www.noc.soton.ac.uk/noc_intranet/metstation/index.html [Accessed: 15/10/11].
- Olesen, B. W. (2007). The philosophy behind EN15251: Indoor environmental criteria for design and calculation of energy performance of buildings. *Energy and Buildings*, 39, 740-749.
- Teli, D. (2013). *Thermal performance and occupant comfort in naturally ventilated UK junior schools outside the heating season*. PhD thesis, University of Southampton.
- Teli, D., James, P. A. B. & Jentsch, M. F. (2013). Thermal comfort in naturally ventilated primary school classrooms. *Building Research & Information*, 41, 301-316.
- Teli, D., Jentsch, M. F. & James, P. A. B. (2012). Naturally ventilated classrooms: An assessment of existing comfort models for predicting the thermal sensation and preference of primary school children. *Energy and Buildings*, 53, 166-182.
- Wargocki, P. & Wyon, D. P. (2007). The Effects of Moderately Raised Classroom Temperatures and Classroom Ventilation Rate on the Performance of Schoolwork by Children (RP-1257). *HVAC&R Research*, 13, 193-220.

Developing assumptions of metabolic rate estimation for primary school children in the calculation of the Fanger PMV model

Shamila Haddad¹, Paul Osmond¹, Steve King¹, Shahin Heidari²

1 University of New South Wales, Australia

2 University of Tehran, Iran

Corresponding author: s.haddad@unsw.edu.au

Abstract

Metabolic heat production is one of the key parameters in maintaining the body's heat balance with the environment. Levels of accuracy and methods for estimation of metabolic rate for various activities are given in most of the commonly used standards, and estimated metabolic rates for an average adult are tabulated to be used where direct measurement is not practical. However, determination of metabolic rate is expected to be different in a younger population compared with that of adults. This paper is part of a larger study that reports on the sensitivity of Predicted Mean Votes of thermal comfort to assumptions of metabolic rates, based on data from field studies in non-air conditioned primary schools in Shiraz, Iran. The outcome of the present study highlights the need for more field-based research in order to examine the accuracy of input parameters in the PMV model while predicting children's thermal sensation in the classroom.

Keywords: Metabolic rate, Thermal comfort, Predicted mean vote, Primary school children

1. Introduction

Fanger's (1970) Predicted Mean Vote (PMV) model is based on heat balance theory, and given to be a function of four environmental and two personal factors: air temperature, mean radiant temperature, relative humidity, air velocity, clothing insulation, and activity level i.e. internal heat production in the body (Fanger, 1973). Metabolic rate is presented in this model (ISO 7730, 2005) in the following forms: resting metabolic rate (RMR, given a value of 58.15 W/m² for an average adult), and MET value which is a measure of activity level (Gagge et al., 1941). The MET value is described as the metabolic rate of a given activity in proportion to the resting rate (ASHRAE, 2009).

The conversion of chemical into mechanical and thermal energy is discussed in ISO 8996 (2004) and IUPS Thermal Commission (2001). For most types of activities, mechanical work is small and can be regarded as zero especially for sedentary activities (ASHRAE, 2009); hence in ISO 8996 (2004) the rate of heat production is regarded as equivalent to metabolic rate.

Metabolic heat production is dependent on activity, person, and environment (ASHRAE, 2009). It is estimated based on body surface area or body mass, to take into account variation between individuals of different body size (Havenith et al., 2002). Havenith states that body surface area directly affects heat balance with the environment, whereas body mass contributes to heat production in "load moving

activities”. Therefore in the heat balance equation metabolic rate is measured in W/m^2 because heat exchange with the environment is a function of area (IUPS Thermal Commission, 2001).

According to Goto et al. (2002) “activity level is probably one of the least well-described parameters of all the parameters that affect thermal sensation, comfort and temperature preferences indoors”. Metabolic rates for different activities were developed based on adults’ physiology. However, age and body size affect the rate of internal heat production. This implies that children’s thermal comfort assessment needs more insight into the influence of metabolic rate on the PMV calculation. This paper reviews relevant literature relating to children’s metabolic rate and reports the sensitivity of the PMV model to assumptions of metabolic rates. The relationship between PMV predictions and thermal sensation during sedentary activities in the classroom is examined, to evaluate the robustness of children’s MET and RMR values derived from the physiology literature.

2. Existing methods for determination of the metabolic rate

ISO 8996 (2004) provides four levels of accuracy and eight methods, where the accuracy and cost of study increase from level one to four (Table 1). As can be inferred, the methods increase in complexity. For instance, method 4B estimates average metabolic rate over longer periods (1-2 weeks); a minimum of six days is required for the test in children. Method 4C is direct calorimetry, where body heat loss is measured while performing an activity in an insulated chamber.

Table 1. Levels and methods for estimation of the metabolic rate based on ISO 8996 (2004)

Level	Method	Accuracy
1.Screening	A: Classification for different occupation	Rough information
	B: Classification for type of activity	Very high risk of error
2.Observation	A: Tables for group assessment	Accuracy: $\pm 20\%$
	B: Tables for specific activities	High risk of error
3.Analysis	Determination of metabolic rate from heart rate measurement under defined conditions	Accuracy: $\pm 10\%$ Medium risk of error
4.Expertise	A: Determination of metabolic rate by measurement of oxygen consumption rate	Accuracy: $\pm 5\%$
	B: Doubly labelled water	
	C: Direct calorimetry	

Other Standards commonly used in thermal comfort assessment tabulate metabolic rates for sedentary activities. ISO 7730 (2005) nominates the metabolic rate for seated relaxed and sedentary activity close to the estimation of metabolic rate for ‘specific activities’ in ISO 8996 (2004). The average metabolic rate by ‘category’ given in ISO 8996 (2004) suggests the ‘average resting’ and ‘low’ metabolic rate as equivalent to $65 W/m^2$ and $100 W/m^2$ respectively. ASHRAE 55 (2010) nominates a metabolic rate for typical seated office activities from $55-70 W/m^2$ including reading seated, writing, typing, and filing while seated. For resting activity while seated quietly the ASHRAE estimate $60W/m^2$.

2.1 Limitations of existing methods in the assessment of thermal comfort

Havenith et al. (2002) show that a 15% error in the estimation of metabolic rate can result in errors in PMV of 0.3 or more and conclude that “for precise comfort assessment a precise measure of metabolic rate is needed”. Of the six input parameters in the calculation of the PMV model, metabolic rate is the most influential

(Gauthier and Shipworth, 2012). Hence, employing the most accurate metabolic rate in the calculation of PMV minimizes the risk of error and uncertainty.

Notwithstanding that more direct methods for determination of metabolic rate can lead to more accurate estimates, the usability of these methods in the field study of thermal comfort is debateable. These methods require special instrumentation and measurement protocols and thereby may interfere with the routine tasks and activities of subjects. Instead, in thermal comfort assessments the screening and observation methods given in ISO 8996 are predominantly used.

Humphreys and Nicol (2002) suggest that PMV is “free from serious bias” for activity levels below 1.4 MET. ASHRAE (2009) similarly states that its tabulated values are sufficiently accurate for well-defined activities with metabolic rates lower than 1.5 MET. Havenith et al. (2002), however, suggest obtaining more data and detailed task description for activities below 2 MET units to improve metabolic rate estimation based on ISO 8996. Moreover, apart from the problem with limited accuracy, tabulated values for various activities may not be applicable for “specific populations or individuals” (Parsons, 2001, Havenith et al., 2002).

Data and tabulated values for estimation of metabolic rate in the ISO standards (ISO 8996, 2004, ISO 7730, 2005) refer to an ‘average’ 30 year old adult (male 70kg, 1.8m² body surface area; female 60 kg, 1.6m² body surface area). Similarly, in (ASHRAE 55, 2010, ASHRAE, 2009) the metabolic rate is nominated for an average adult, with the skin surface area = 1.8 m² as estimated based by Du Bois and Du Bois (1916). Furthermore, the ISO standards estimate the metabolic rate of school activity as equal to office work, and require appropriate corrections when dealing with children (ISO 8996, 2004) because children’s body surface area and mass are lower than those of adults.

3. Physiological basis for determination of metabolic rate for children

3.1 Definition and origin of MET

A MET is generally defined as the rate of energy expenditure (EE) by a human at rest in thermoneutral conditions; however there are many different ways of quantifying it (Olds, personal communication, 23 August 2013). By definition, MET can be derived by the ratio of activity metabolic rate to the standard resting metabolic rate of 1 kcal (4.184 kJ)/kg/h, (Ainsworth et al., 1993) thus 1 MET corresponds to the resting metabolic rate when sitting quietly.

To describe the heat exchange of a man with the surrounding environment, Gagge et al. (1941) proposed a uniform practical unit mutually understandable among the three groups of heating engineers, physicians and the physiologists concerned with human heat exchange with the environment. The term ‘mets’ originated with Gagge et al. (1941) where a thermal activity unit is equivalent to 50kcal/h/m² or 18.5Btu/h.ft² based on the metabolism of a person sitting at rest in a thermal comfort state. As 1 ‘met’ unit is dependent on the size of individuals, for an average size person it is taken as equal to 100 W.

In work and exercise physiology, MET is usually determined by reference to the amount of oxygen consumption where 1 MET is approximately equivalent to resting oxygen intake of 3.5 ml/kg/min for an average adult (Ainsworth et al., 1993). A similar definition is given by Jette et al. (1990) in which a MET refers to the amount of oxygen consumed at rest when sitting quietly in a chair. The energy cost of an activity expressed in MET can be determined by the ratio of the relative oxygen cost

of the activity (ml/kg/min) to 3.5. However, as pointed out in Harrell et al. (2005), the origin of the standard value defining 1 MET (3.5 ml/kg/min) is unclear.

It is given that resting oxygen consumption in children is somewhat more than this standard value (Olds, personal communication, 23 August 2013). It is also reported by Amorim (2007) that this value underestimates actual resting oxygen consumption and resting EE of children. A similar trend with children aged 8-18 years is highlighted in Harrell et al. (2005), where mean resting oxygen intake and adjusted resting EE are equivalent to 5.92 ml/kg/min and 1.71 ± 0.41 kcal/kg/h respectively. Therefore, the application of standard resting oxygen consumption for children is not correct because the relationship between oxygen consumption and body size is not linear (Taylor, personal communication, 26 August 2013).

3.2 Basal and resting metabolic rate

Basal metabolic rate (BMR) as defined by McIntyre (1980, p. 87) is the minimum rate of energy production from the human body. It is often derived from measurement of oxygen consumption in a fully awake subject having fasted for 12 hours after resting quietly for 20-30 min in a thermoneutral condition prior to the measurement (Wong et al., 1996). Due to methodological difficulties in providing these standard conditions, an alternative 'resting metabolic rate' (RMR) is used which "requires an interval of only four hours following a light meal and a relatively short measurement time of between 30 to 60 minutes" (Amorim, 2007).

Basal metabolic rate differs in proportion to body surface area (Rhoades and Bell, 2013, p. 554) which is taken as proportional to the $2/3$ power of body mass (IUPS Thermal Commission, 2001). However, Kleiber (1947) reviews the correlation between metabolic rate and body size based on zoology studies and concludes that BMR is more nearly proportional to the $3/4$ power of body weight. The non-linear treatment is very important when dealing with children (Taylor, personal communication, 26 August 2013). Despite this, in many biological studies RMR value is expressed in terms of simple ratio scaling of body mass.

BMR is a function of several factors; including age and sex (McIntyre, 1980), stage of puberty (Harrell et al., 2005), body surface area, hormones, and digestion (Rhoades and Bell, 2013, p. 554). In a resting and fasting young adult man, who weighs 70 kg, and is 170 cm tall, body surface area (BSA) close to 1.8m^2 , taking the usual oxygen equivalent of 1 MET (3.5 ml/kg/min) into account, BMR equates to 86W ($3.5\text{ml/kg/min} \times 70\text{ kg} = 0.245\text{ l/min} \times 21\text{ kJ/l} = 5,145\text{ J/min} = 86\text{ W} \rightarrow 48\text{ W/m}^2$) (Olds, personal communication, 23 August 2013). Rhoades and Bell (2013, p. 554) suggest a similar value for a young adult man of about 45 W/m^2 .

Children's resting metabolic rate normalised for BSA is generally higher than the BSA-normalised values for adults (Olds, personal communication, 23 August 2013). Boothby et al. (1936) show that the basal metabolism per unit of body surface area expressed as calories per square meter per hour declines with age; being highest at age six for both sexes. According to the same study, the fall in basal metabolism is more rapid during early childhood and adolescence and slows thereafter into old age. Further, Holliday (1971) found that resting metabolic rate per kilogram body weight is higher in children compared to adults. Similarly, Harrell et al. (2005) concludes that "energy expenditure per kilogram of body mass at rest or during exercise is greater in children than adults and varies with pubertal status".

3.2.1 Estimation of RMR for children

Children’s metabolic rate at rest has been reported variously in the literature, as studies vary in their methodological approaches. The review of previous studies by Amorim (2007) shows that RMR values vary from 1012 to 1420 and 1133 to 1358 (kcal/day) corresponding to lying and sitting positions respectively. Apart from difficulties imposed by the cost and availability of equipment, and measurement time (Finan et al., 1997), RMR measurement requires subjects’ cooperation (Wong et al., 1996). Determining RMR in children under standardized conditions is considered “very tedious as it is imperative that children rest quietly over an extended period of time under the same conditions to gain reliable results” (Amorim, 2007). Therefore, several equations have been developed to predict RMR specifically for children.

The study by Schofield (1985) reviews 50 years of literature on basal metabolism and computes the widely used equations to predict RMR based on data obtained from a large heterogeneous sample from developed and underdeveloped countries from 1935 to 1985. These equations are used to simply predict RMR from weight (W) or from weight and height (WH) for different age groups and genders. The other frequently used equations are formulated by the Food and Agriculture/World Health Organization/United Nations University (FAO/WHO/UNU, 1985) to estimate BMR from body weight. These prediction equations are based on BMR values derived from worldwide measurements of resting energy expenditure (REE) in children and adolescents (Table 2).

Table 2. BMR prediction equations for children - W: weight (kg), H: height (m), F: female, M: male.

Author	Equation for BMR (MJ/24 h)	R
Schofield-W	M(3-10 yr): $BMR = 0.095W + 2.11$	0.83
	F(3-10 yr): $BMR = 0.085W + 2.033$	0.81
	M(10-18 yr): $BMR = 0.074W + 2.754$	0.93
	F(10-18 yr): $BMR = 0.056W + 2.898$	0.80
Schofield-WH	M(3-10 yr): $BMR = 0.082W + 0.545H + 1.736$	0.83
	F(3-10 yr): $BMR = 0.071W + 0.677H + 1.553$	0.81
	M(10-18 yr): $BMR = 0.068W + 0.574H + 2.157$	0.93
	F(10-18 yr): $BMR = 0.035W + 1.948H + 0.837$	0.82
FAO/WHO/UNU	M (3–10 yr): $BMR = 0.0949W + 2.07$	0.86
	F (3–10 yr): $BMR = 0.0941W + 2.09$	0.85
	M (10–18 yr): $BMR = 0.0732W + 2.72$	0.90
	F(10–18 yr): $BMR = 0.0510W + 3.12$	0.75

These equations has been validated in a number of studies (e.g. Rodriguez et al., 2002) where measurement are obtained in steady state thermoneutral condition on fully awake supine subjects.

3.3 Body surface area prediction equations

Body surface area is used in physiology to normalize metabolic rate of individuals of different body size. The correlation between body height, weight and surface area is given in different studies (e.g. Du Bois and Du Bois, 1916, Mosteller, 1987, Haycock et al., 1978) (Table 3). The formula provided by Du Bois and Du Bois (1916) has been widely used to estimate body surface area of subjects from height and weight. The Du Bois and Du Bois equation is validated with respect to adults and is not recommended to be applied in infants and young children (Haycock et al., 1978). The height and weight body surface area equation provided by Haycock et al. (1978) has

been validated in infants, children, and adults with a wide range of samples varying in body shape and size. Children of different ethnicities were included in this study. The Mosteller formula (Mosteller, 1987) is also used for calculation of surface area. It is simpler than other formulas, and its deviation from values predicted by the Du Bois and Du Bois equation is less than 2% (Mosteller, 1987).

Table 3. Body surface area formula from body weight (W) and height (H)

Author	Year	Formulas
(Du Bois and Du Bois)	1916	$A_{Du} (m^2) = 0.202 W (kg)^{0.425} \times H (m)^{0.725}$
(Haycock et al.)	1978	$SA (m^2) = W (kg)^{0.5378} \times H (cm)^{0.3964} \times 0.024265$
(Mosteller)	1987	$BSA(m^2) = [H (cm) \times W (kg) / 3600]^{0.5}$

4. Review of previous thermal comfort studies in schools

The study by Havenith (2007) identified metabolic rate values corresponding to physical activity levels of 25 primary school children 9-11 years old, which were determined during different class activities using an indirect calorimeter (Table 4). The study shows that the metabolic rate of children during seated activities is lower than estimated metabolic rate for seated office work activities based on ISO Standards; i.e. 52 to 64 W/m² for 9-11 years old, and 62 and 64 W/m² for children 10-11 years old. The lower metabolic rate of school children per unit of surface area compared to estimated values in ISO 8996 (2004) was explained by their body size and the larger ratio of body surface area to mass (Havenith, 2007).

Table 4. Determination of metabolic rate for primary school children based on Havenith (2007)

Lesson	Sample size	Age	Description of activity (seated)	Metabolic rate-W	Metabolic rate-W/m ²
Language assignment	5	9-10	Working individually on worksheets	63	52
Writing task	5	9-10	Writing story	68	53
Art	5	9-10	Cutting and pasting with paper	77	59
Drawing	5	10-11	Seated activity	79	62
Calculus	5	10-11	Listening to teacher-follow book material	84	64

Children's metabolic heat production has been adjusted variously in a number of thermal comfort studies in schools to represent actual metabolic rate of children for calculation of PMV. A brief review of these approaches was presented in a previous paper (Haddad et al., 2013).

Children's metabolic rate in Al-Rashidi et al. (2009) was corrected based on the findings of Havenith (2007). However, both PMV and adjusted PMV under predict and over predict students' actual thermal sensation on the warm and cool side of neutral respectively, on the ASHRAE scale.

Mors et al. (2011) corrected mean metabolic rate for the reduced body surface area of children and found that the corresponding PMV underestimates children's thermal sensation. This investigation also showed that underestimation of PMV would be larger using children's actual metabolic rate based on Havenith (2007) than using body surface area corrected metabolism.

The recent study by Teli et al. (2012) applies four different adjustment approaches to address the metabolic rate of primary school children in naturally ventilated classrooms (table 5).

Table 5. Determination of metabolic rate for children based on (Teli et al., 2012). 1: Child RMR based on Amorim (2007) 2: Average activity metabolic rate base on Havenith (2007)

MET	RMR	Estimated values	PMV prediction
Estimated from children's RMR ¹ and activity metabolic rate ²	Unchanged	RMR=58.15W/m ² MET=1.2	PMV underestimates TSV
Corrected for body surface area	Unchanged	RMR=58.15W/m ² MET=1.8	PMV underestimates TSV
Corrected for body surface area	Corrected for body surface area	RMR=88.25W/m ² MET=1.2	PMV overestimates TSV
Estimated from children's RMR ¹ and activity metabolic rate ²	Estimated from child RMR ¹	RMR ¹ = 48.8W/m ² MET=1.2	Large deviation between PMV and TSV

There is a poor agreement between previous thermal comfort studies in regards to estimation of metabolic rate for children. However, a more precise measure of metabolic rate is required for more accurate thermal comfort assessment (Van Hoof, 2008). To minimize uncertainty in metabolic rate estimation in the assessment of children's thermal comfort and examine the suitability of PMV for prediction of survey results, a sensitivity analysis was conducted and is reported in this paper, which sets a range of child-specific MET rates and RMR values in the PMV equation.

5. Methods

This study follows conventional techniques and protocols for data gathering commonly used in thermal comfort field surveys. For a detailed discussion of the questionnaire designed for the target age group see Haddad et al. (2012).

5.1 Subjects

Three campaigns of combined subjective and objective study were conducted with children aged 10-12 years in 58 classrooms located in seven nearby boys' and girls' primary schools in Shiraz, Iran. Data collection in this study was carried out in the warm and cool seasons of the school year (2012-2013) with about 1600 healthy subjects.

The subject school buildings were naturally ventilated using operable windows and equipped with mechanical cooling systems and water heating systems; i.e. evaporative coolers and radiators. Cooling systems were switched off during the survey period and heaters were occasionally operated in the cooler month.

Students' physical activity levels in the surveyed classrooms were effectively constant across all schools and for all seasons because the students had more or less the same posture and were involved in activities with similar duration and intensity during class—predominantly restricted to reading, writing, and listening to the teacher while seated for 45 minutes.

5.1.1 Body surface area

In a previous study, (Haddad et al., 2013) the body surface area of an average child of 10-12 years was derived from the literature, i.e. 1.14m² in line with Mors et al. (2011) and Teli et al. (2012). For further refinement of likely accuracy, body weight and height of Shirazi school children were taken from the study by Ayatollahi and Bagheri (2010) as a baseline to estimate body surface area of an average child 10-12 years old. Children's BSA was predicted based on the three equations mentioned previously. Table 6 summarises the minor differences between calculated BSAs based on these formulas.

Table 6. Body surface area of Shirazi school children

Formula	BSA (m ²)		
	Female	Male	Average
Du Bois and Du Bois (1916)	1.125	1.109	1.117
Haycock et al. (1978)	1.116	1.101	1.109
Mosteller (1987)	1.120	1.105	1.113

5.2 Study design

Several factors can lead to elevation in the estimated MET value: e.g. stressful activity (Fanger, 1994); performing mental tasks (Wyon et al., 1975); and the intensity, type, duration, and frequency of physical activity (Chen and Bassett, 2005). These are of importance in school settings where students mostly perform medium to vigorous activity during the breaks and may participate in stressful activities such as exams.

Further, the actual rate of energy expenditure in the classroom may be affected by three factors: 1) whether the children were active immediately before; 2) whether they have just eaten; and 3) the ambient temperature and relative humidity. Taylor (personal communication, June 21, 2013) also suggests that high-intensity and long-duration exercise results in a protracted elevation in resting metabolic rate.

In this study, children engaged in different activities during the 15 minute school break in which the intensities varied from light to high; i.e. sitting and relaxing 1.1 MET to playing in the school yard 6.3 MET as suggested in the *Compendium of Energy Expenditures for Youth* (Ridley et al., 2008). A study by Goto et al (2002) suggests that even short duration of activity could affect thermal sensations. The authors subsequently recommend that subjects need to maintain a stable level of activity for at least 15-20 minutes in order to have static thermal responses (Goto et al., 2006).

According to Toftum (personal communication, June 3, 2013) MET rate is expected to level off towards RMR; however it may not achieve this completely during 45 min. Accordingly, the thermal comfort survey was conducted during the last 5 min of the class session, to minimize the effects of any activities during the previous break.

5.2.1 Estimation of resting metabolic rate

In the authors' previous study (Haddad et al., 2013), three different RMR values were varied inside the PMV equation in line with Teli et al. (2012), mainly to enable comparison of PMV predictions between studies.

Given the difficulties in measurement of oxygen consumption particularly in a field study of thermal comfort with children, and methodological variability in the literature on measurement of RMR in children, this study employs Schofield's age-

gender specific formulas (Schofield, 1985) to predict children’s RMR. Schofield-W and Schofield-WH were derived from actual body height and weight of children for both male and female students (Table 7). Although Schofield-W and Schofield-WH suggested similar results, predictions of Schofield-WH were used, in accordance with the outcome of the study by Rodriguez et al. (2002) where RMR is a linear function of body weight and height.

For repeatability of the thermal comfort work, children’s resting metabolic rates per unit of body surface area were calculated from RMR based on the Schofield-WH formula, divided by children’s body surface area based on the Du Bois and Du Bois equation. Table 8 shows the derivation of RMR values normalized for body surface area based on three BSA formulas. Notwithstanding that there are minor differences between the values from the three BSA equations given in Table 8, the Du Bois and Du Bois BSA formula was used for normalizing metabolic rate, since it has been commonly used in the thermal comfort literature.

Table 7. Resting energy expenditure based on Schofield (1985)

Resting Energy Expenditure				
Gender-Age	BMR (MJ/24hr)		BMR (Watts)	
	Schofield-W	Schofield-WH	Schofield-W	Schofield-WH
Male (10-18 yr)	5.118	5.119	59.239	59.249
Female (10-18 yr)	4.721	4.679	54.638	54.156

It is noteworthy that basal and resting values can be similar, or can differ considerably (Taylor, personal communication, June, 21, 2013). That is because of the typical standardisation procedures that must be adhered to prior to basal reading for obtaining reliable measurements, as discussed in Section 3.2.

Since both meals and previous activity will increase metabolic rate, “it is likely that Schofield and similar equations will underestimate RMR if the child has recently eaten and/or has recently been active” (Olds, personal communication, December, 15, 2013).

Table 8. Resting metabolic rate normalized for body surface area

RMR (W/m ²)						
BSA formula	Schofield (1985)-W			Schofield (1985)-WH		
	Female	Male	Average	Female	Male	Average
(Du Bois and Du Bois)	48.55	53.39	50.97	48.12	53.40	50.76
(Haycock et al.)	48.96	53.80	51.38	48.53	53.81	51.17
(Mosteller)	48.78	53.61	51.19	48.35	53.62	50.98

5.2.2 Estimation of MET value

Different approaches have been presented to estimate the energy cost of activities for children. The review of published data by Ridley and Olds (2008) suggests that the magnitude of error is small “using adults METs, combined with child resting metabolic rates, as the best existing technique to assign EE to children when measured values are not available”.

Torun (1989) indicates that when energy costs are expressed as a multiple of RMR, values are similar for boys and girls with no age-related differences in sedentary activities. For children under 15 years, lying down = 1.1 METs and sitting = 1.2 METs.

The youth compendium of energy expenditure developed by Ridley et al. (2008) provides a coding system on the energy cost of children and adolescents performing activities including school work based on the review of data undertaken by Ridley and Olds (2008). A MET value of 1.4 is assigned for the energy cost of activities entitled “sitting quietly” and “writing-sitting”, and 1.3 MET is assigned to “reading-sitting” (Ridley et al., 2008).

5.3 Calculation of PMV

Children’s mean thermal sensation votes (TSV) from 58 surveyed classrooms were then considered to investigate the PMV-TSV correlation. Physical variables including air temperature, globe temperature, air speed and relative humidity were collected concurrently during the surveys consistent with standards (ISO 7726, 2001, ASHRAE 55, 2010) from a Class 1 array of instruments placed at heights of 1.1m, 0.6m and 0.1m above the floor near the middle of each classroom.

PMV was calculated with a weighted average clo value. Two values were estimated for girls and boys depending on whether students wore jackets on top of their uniforms: 0.93, 0.65 for boys and 1.12, 0.84 for girls in the cold season and 0.86, 0.61 for boys and 1.02, 0.77 for girls during the warmer month. To calculate PMV-PPD according to the PMV equation (ISO 7730, 2005), the Basic code given in ASHRAE 55 (2010) was implemented in MATLAB computer software. This allows changing adults’ RMR (58.15 W/m²) to the values corresponding to children for the purpose of sensitivity analysis.

6. Analysis and results

To understand PMV sensitivity relative to metabolic rate, PMV was calculated as a function of RMR and MET. As in (Haddad et al., 2013), MET values range from 1 to 1.4, and RMR= 58.15, 48.8, 88.25W/m². Additionally, in this study child-specific RMR was employed that was estimated based on the Schofield equations, i.e. 50.76 W/m².

Thermal neutrality was derived based on the mean thermal sensation vote as a function of operative temperature; $TSV_{(mean)}=0.23T_{op}-5.24$, $r^2= 0.757$. For each interval of MET and RMR value, one linear regression was generated to assess neutral temperature predicted by PMV and that governed by actual thermal sensation mean votes of the children. Figure 1 illustrates linear regression models derived from predicted PMVs and actual TSV versus operative temperature. The outcome of the regressions shows that PMV varies significantly with changes in RMR.

Taking all intervals of MET into account, RMR values corresponding to children result in discrepancies in predictions of PMVs: RMRs of 48.8 and 50.76 W/m² lead to underestimation of PMV. A similar trend is suggested where data obtained during cold and warm seasons are analysed separately; PMV with values measured or estimated for children underestimates mean TSV of the surveyed students. This result is consistent with observation made by Teli et al. (2012) where PMV with child-specific RMR and MET=1.2 underestimates children’s TSV, however, a larger deviation is observed in Teli et al. (2012).

In contrast with child-specific RMR, size corrected adult RMR, i.e. 88.25W/m² consistently falls above the regression line of actual thermal sensation of students. This indicates that correcting adults’ RMR for the smaller body surface area of children is not an appropriate approach because the relation with surface area is different for children (Havenith, personal communication, June 25, 2013).

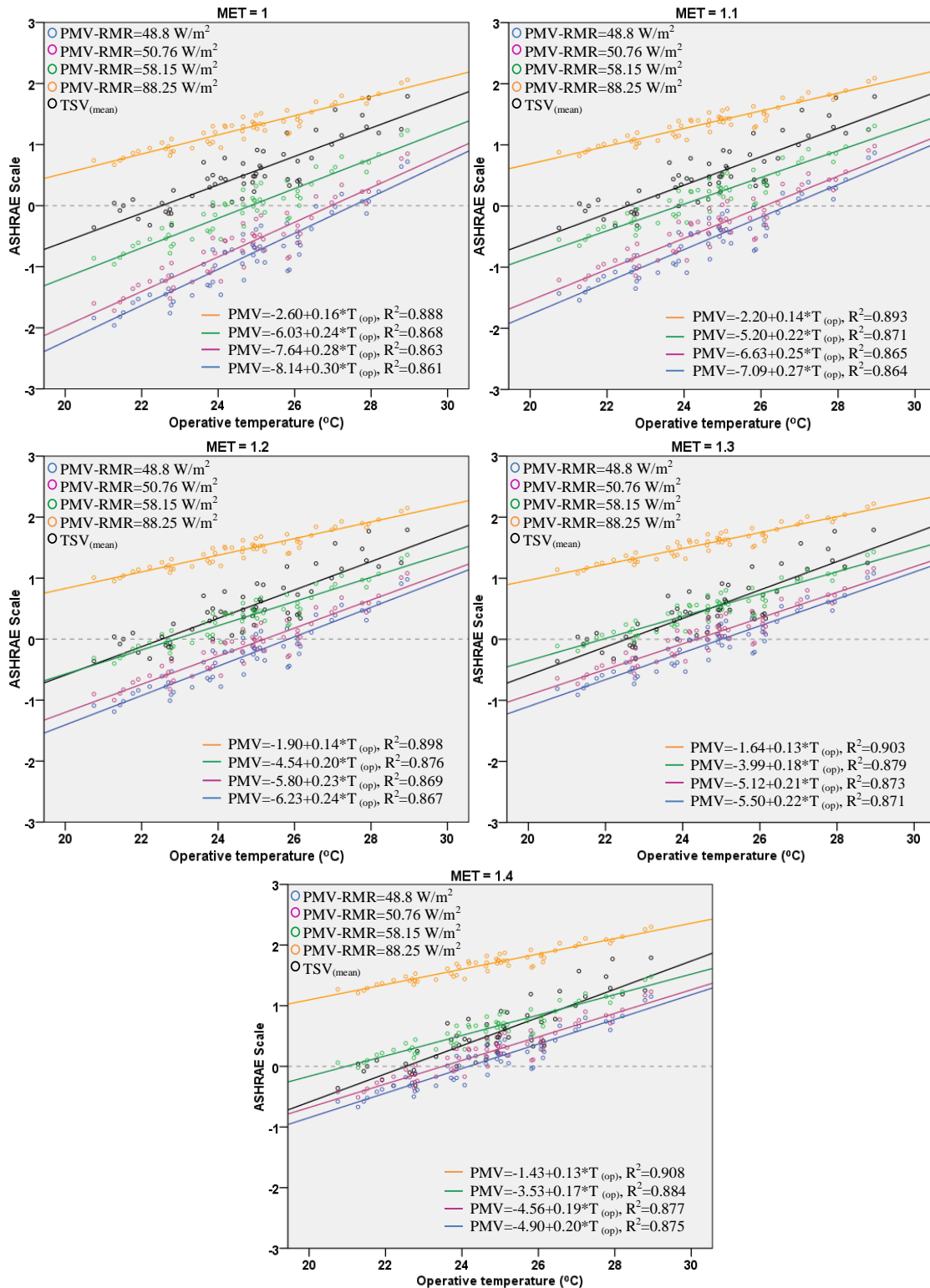

Figure 1. Linear regression calculation based on mean TSV and PMVs (vs.) operative temperature (°C)

Regression analysis used to explore the relations between PMV and TSV shows a PMV regression line with child-specific RMR and MET=1.4 closer to the line representing the actual mean votes of the students, even though it slightly under-predicts TSV. To determine a metabolic rate for sedentary activity in the classroom, predicted RMR based on Schofield (1985) is multiplied by a MET value of 1.4 and 1.3 as given in Ridley et al. (2008) for seated class activity. The resulting values for

the sample vary between 65.98 and 71.1 W/m² which is within the lower range of metabolic rates given in Nicol and Humphreys (1973) for classroom activities, 60-80W/m².

Analysis shows that the PMV fitted line slightly underestimates TSV where RMR was kept unchanged in the original PMV equation i.e. 58.15 W/m² and MET=1.2 for sedentary school activity. This could be explained by less opportunity for adaptive behaviour in the classroom or greater sensitivity of children to higher temperature.

For the purpose of sensitivity analysis, in this study loss function analysis was employed using Eq.1 in order to define a combination of MET and RMR such that PMV predictions are close to children's TSV_(mean). In this equation, the "j" indices correspond to number of classrooms where J=58 and the "i" indices refer to each (RMR, MET) combination. A lower value of L_i indicates that the PMV model is showing results that are closer to reality (TSV).

Eq.1. Loss function equation to find (RMR, MET)

$$L_i = \sqrt{\frac{1}{j} \sum_{j=1}^J (TSV_{(mean)} - PMV_j)^2}$$

A contour plot was derived to illustrate the effects of different RMR and MET combinations and the resulting L_i factors (figure 2). The dark blue area represents the combination of RMRs and METs that give the lowest L_i. The middle of this area can be captured as representing the combination of RMR and MET values with minimum discrepancy between PMV and actual votes of students. Among intervals of MET and RMR used in the sensitivity analysis, the lowest L_i of 0.26 was suggested by RMR=58.15 W/m² and MET=1.3.

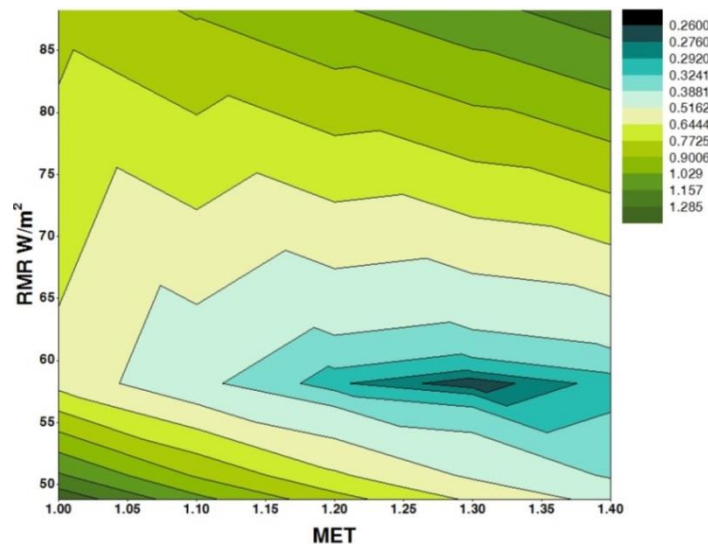

Figure 2. Contour plot for all combination of MET and RMR

7. Discussion

The use of either BMR calculated from the Schofield equation (50.76 W/m²) or RMR as commonly applied in adult thermal comfort studies (58.15 W/m²) to predict PMV contributes to internal uncertainty in comparing children's TSV with that of adults. Apart from assumptions of metabolic rate, a systematic uncertainty in the calculation

of PMV may be introduced by: 1) sensitivity of PMV to other variables, essentially estimation of clothing and chair insulation 2) other physiological variables and assumptions, e.g. mean skin temperature and sweat secretion which are given as a function of metabolic rate in the PMV equation.

In this study thermal insulation provided by wooden chairs used in the classrooms is estimated in line with standards (ASHRAE 55, 2010, ISO 7730, 2005) i.e. $I_{clu} = 0.01$ and added to the entire clothing ensembles. However, several factors influence chair insulation; e.g. contact area between the body and chair, posture, and type of chair, (McCullough et al., 1994). Therefore, estimation of additional insulation provided by chairs may contribute to the uncertainty in the PMV predictions.

Skin temperatures and sweat rates are the only physiological parameters which affect heat balance and that depend on activity level (Fanger, 1970, p. 21). Since these values vary with activity and individuals (Olesen, 1982), there is a need for more in-depth research into the physiological comfort conditions and implication of skin temperature and sweat secretion in the heat balance equation for children.

Compared with adults, children have a higher surface area to mass ratio (Parsons, 2003, p. 147, Bar-Or, 1989, p. 337). Therefore, the rate of heat exchange between the environment and body is higher in children than adults (Parsons, 2003, p. 147). Notwithstanding that geometric and physiological characteristics of children are different from those of adults, according to Bar-Or (1989, p. 354) “children seem to be as effective thermoregulators as adults in ambient conditions that are neither very hot nor very cold”. However, in terms of temperature regulation, Bar-Or (1989) concludes that “compared with adults, children dissipate heat less through evaporation and more through convection plus radiation, which is achieved by greater vasodilation”. Further discussion is beyond the scope of this field study since children were not involved in high intensity activity and not exposed to extreme environmental conditions in the classroom.

8. Conclusion

The validity of PMV predictions in relation to assumptions of metabolic rate were examined based on data collected from field work in non-air conditioned primary schools in Shiraz, Iran. This study employs intervals of MET rates and RMRs to assess the suitability of adjustment approaches in the calculation of PMV, and understand the effects of children’s metabolic rate on PMV predictions. The outcome of this study highlights the importance of metabolic rate in the prediction of PMV.

The first conclusion is that PMV is sensitive to RMR. Changing RMR values for children at neutral temperature leads to deviations from actual neutral votes which might have different explanations. The most likely explanation is that the PMV model was developed under laboratory conditions on the basis of adults’ physiology and any change in this equation may result in over or underestimation of actual thermal sensation of children. PMV predictions with child-specific RMR underestimate TSV of sample children which can be explained by issues with methodology.

Several factors can lead to elevation of resting metabolism from basal level, e.g. higher rate of activity during school breaks. Therefore, it seems reasonable to assume that children’s actual RMR during quiet sitting in the classroom would be higher than values obtained from estimated or measured BMR derived under ideal conditions. Measurement of metabolic rate during resting state and class activities would

eliminate uncertainty in predictions of the comfort equation for children. However, this is hardly practical in a field study of thermal comfort.

The analysis also suggests that PMV predictions based on the original RMR in Fanger's PMV equation ($58.15\text{W}/\text{m}^2$) and $\text{MET} = 1.3$, are more robust compared to other values estimated or adjusted specifically for children. However, the literature predominantly indicates that children's resting metabolic rate per unit of body size is higher than that of adults, whereas published data for children (either estimated or measured) suggests lower values than the RMR value of $58.15\text{W}/\text{m}^2$ used in the heat balance for adults. Therefore acknowledging the important role of metabolic rate estimation in assessment of thermal comfort, it would be desirable to obtain actual field measurements of subjects' RMR using calorimeters and reconsider its implication in the PMV equation in order to attain more confidence in this conclusion.

9. Acknowledgments

Gaps and limitations in the literature led to an unusual amount of personal communication being cited in this paper. Thanks to Professors Olds, Taylor, Havenith, de Dear and Toftum for their advice and constructive feedback.

References

- Ainsworth, B. E., Haskell, W. L., Leon, A. S., Jacobs, D. R., Montoye, H. J., Sallis, J. F. & Paffenbarger, R. S. 1993. Compendium of physical activities: classification of energy costs of human physical activities. *Medicine and science in sports and exercise*, 25, 71-80.
- Al-Rashidi, K. E., Loveday, D. L. & Al-Mutawa, N. K. 2009. Investigating the Applicability of Different Thermal Comfort Models in Kuwait Classrooms Operated in Hybrid Air-Conditioning Mode. *Sustainability in Energy and Buildings*, 347-355.
- Amorim, P. R. d. S. 2007. *Energy expenditure and physical activity patterns in children: applicability of simultaneous methods*. Queensland University of Technology.
- ASHRAE 55 2010. ANSI/ASHRAE Standard 55-2010, Thermal Environmental Conditions for human Occupancy. Atlanta, GA, USA: American Society of Heating, Refrigeration and Air Conditioning Engineers, Inc.
- ASHRAE 2009. ASHRAE Handbook - Fundamentals American Society of Heating, Refrigeration and Air Conditioning Engineers, Inc.
- Ayatollahi, S. M. T. & Bagheri, Z. 2010. New Trends in Weight-for-Height Charts of Shirazi School Children in Relation to the CDC Reference Data. *Iranian journal of pediatrics*, 20.
- Bar-Or, O. 1989. *Temperature regulation during exercise in children and adolescents*, Perspectives in Exercise Science and Sports Medicine, II. Youth, Exercise and Sport. Indianapolis, IN: Benchmark Press.
- Boothby, W. M., Berkson, J. & Dunn, H. L. 1936. Studies of the energy of metabolism of normal individuals: a standard for basal metabolism, with a nomogram for clinical application. *American Journal of Physiology--Legacy Content*, 116, 468-484.
- Chen, K. Y. & Bassett, D. R. 2005. The technology of accelerometry-based activity monitors: current and future. *Medicine and science in sports and exercise*, 37, S490.
- Du Bois, D. & Du Bois, E. F. 1916. Clinical calorimetry: tenth paper a formula to estimate the approximate surface area if height and weight be known. *Archives of Internal Medicine*, 17, 863.
- Fanger, P. 1994. How to apply models predicting thermal sensation and discomfort in practice. *Thermal comfort: Past, present and future*, 11-17.
- Fanger, P. O. 1970. *Thermal comfort: analysis and applications in environmental engineering*, Danish Technical Press Copenhagen.
- Fanger, P. O. 1973. Assessment of man's thermal comfort in practice. *British journal of industrial medicine*, 30, 313-324.

- FAO/WHO/UNU 1985. *Energy and Protein Requirements: Report of a Joint FAO/WHO/UNU Expert Consultation*, Geneva, World Health Organization.
- Finan, K., Larson, D. E. & Goran, M. I. 1997. Cross-Validation of Prediction Equations for Resting Energy Expenditure in Young, Healthy Children. *Journal of the American Dietetic Association*, 97, 140-145.
- Gagge, A. P., Burton, A. C. & Bazett, H. C. 1941. A practical system of units for the description of the heat exchange of man with his environment. *Science*, 94, 428-430.
- Gauthier, S. & Shipworth, D. 2012. Predictive thermal comfort model: Are current field studies measuring the most influential variables? *7th Windsor Conference: The Changing Context of Comfort in an Unpredictable World*. Cumberland Lodge, Windsor, UK: NCEUB (Network for Comfort and Energy Use in Buildings).
- Goto, T., Toftum, J., de Dear, R. & Fanger, P. 2006. Thermal sensation and thermophysiological responses to metabolic step-changes. *International Journal of Biometeorology*, 50, 323-332.
- Goto, T., Toftum, J., de Dear, R. & Fanger, P. O. Thermal sensation and comfort with transient metabolic rates. Proceedings of Indoor Air Conference, Monterey, USA. June, 2002.
- Haddad, S., King, S., Osmond, P. & Heidari, S. Questionnaire design to determine children's thermal sensation, preference and acceptability in the classroom. PLEA, 2012 Lima, Peru
- Haddad, S., Osmond, P. & King, S. METABOLIC RATE ESTIMATION IN THE CALCULATION OF THE PMV FOR CHILDREN. In: SCHNABEL, M. A., ed. Cutting Edge: 47th International Conference of the Architectural Science Association, 2013 Hong Kong. 241-250.
- Harrell, J. S., McMurray, R. G., Baggett, C. D., Pennell, M. L., Pearce, P. F. & Bangdiwala, S. I. 2005. Energy costs of physical activities in children and adolescents. *Med Sci Sports Exerc*, 37, 329-36.
- Havenith, G. 2007. Metabolic rate and clothing insulation data of children and adolescents during various school activities. *Ergonomics*, 50, 1689-1701.
- Havenith, G., Holmér, I. & Parsons, K. 2002. Personal factors in thermal comfort assessment: clothing properties and metabolic heat production. *Energy and Buildings*, 34, 581-591.
- Haycock, G. B., Schwartz, G. J. & Wisotsky, D. H. 1978. Geometric method for measuring body surface area: A height-weight formula validated in infants, children, and adults. *The Journal of Pediatrics*, 93, 62-66.
- Humphreys, M. A. & Nicol, J. F. 2002. The validity of ISO-PMV for predicting comfort votes in every-day thermal environments. *Energy and Buildings*, 34, 667-684.
- ISO 7726 2001. Ergonomics of the thermal environment. Instruments for measuring physical quantities. International Standards Organization.
- ISO 7730 2005. Ergonomics of Thermal environment analytical determination and interpretation of thermal comfort using calculation of the PMV and PPD indices and local thermal comfort criteria. London: International Standards Organization.
- ISO 8996 2004. Ergonomics of the thermal environment – Determination of metabolic rate. Geneva, Switzerland: International Organization for Standardization.
- IUPS Thermal Commission 2001. Glossary of terms for thermal physiology. *Japanese Journal of Physiology*, 51, 245-280.
- Jette, M., Sidney, K. & Blümchen, G. 1990. Metabolic equivalents (METS) in exercise testing, exercise prescription, and evaluation of functional capacity. *Clinical cardiology*, 13, 555-565.
- Kleiber, M. 1947. Body size and metabolic rate. *Physiol. Rev*, 27, 511-541.
- McCullough, E. A., Olesen, B. W. & Hong, S. Thermal insulation provided by chairs. 1994. 795-802.
- McIntyre, D. A. 1980. *Indoor climate*, Applied Science Publishers London.

- Mors, S. t., Hensen, J. L. M., Loomans, M. G. L. C. & Boerstra, A. C. 2011. Adaptive thermal comfort in primary school classrooms: Creating and validating PMV-based comfort charts. *Building and Environment*, 46, 2454-2461.
- Mosteller, R. 1987. Simplified calculation of body-surface area. *The New England journal of medicine*, 317, 1098.
- Nicol, J. F. & Humphreys, M. A. 1973. Thermal comfort as part of a self-regulating system. *Building Research and Practice*, 1, 174-179.
- Olesen, B. 1982. Thermal comfort. *Technical review*, 2, 3-41.
- Parsons, K. 2001. The estimation of metabolic heat for use in the assessment of thermal comfort. *Moving Thermal Comfort Standards into the 21st Century*. Windsor, UK.
- Parsons, K. C. 2003. *Human thermal environments: the effects of hot, moderate, and cold environments on human health, comfort, and performance*, CRC Press.
- Rhoades, R. A. & Bell, D. R. 2013. *Medical physiology : principles for clinical medicine*, Baltimore, MD : Wolters Kluwer/Lippincott Williams & Wilkins, c2013.
- Ridley, K., Ainsworth, B. E. & Olds, T. S. 2008. Development of a compendium of energy expenditures for youth. *International Journal of Behavioral Nutrition and Physical Activity*, 5, 45.
- Ridley, K. & Olds, T. 2008. Assigning energy costs to activities in children: a review and synthesis. *Medicine+ Science in Sports+ Exercise*, 40, 1439.
- Rodriguez, G., Moreno, L. A., Sarria, A., Fleta, J. & Bueno, M. 2002. Resting energy expenditure in children and adolescents: agreement between calorimetry and prediction equations. *Clinical Nutrition*, 21, 255-260.
- Schofield, W. 1985. Predicting basal metabolic rate, new standards and review of previous work. *Human nutrition. Clinical nutrition*, 39, 5-41.
- Teli, D., Jentsch, M. F. & James, P. A. B. 2012. Naturally ventilated classrooms: An assessment of existing comfort models for predicting the thermal sensation and preference of primary school children. *Energy and Buildings*, 53, 166-182.
- Van Hoof, J. 2008. Forty years of Fanger's model of thermal comfort: comfort for all? *Indoor Air*, 18, 182-201.
- Wong, W. W., Butte, N. F., Hergenroeder, A. C., Hill, R. B., Stuff, J. E. & Smith, E. B. 1996. Are basal metabolic rate prediction equations appropriate for female children and adolescents? *Journal of Applied Physiology*, 81, 2407-2414.
- Wyon, D. P., Fanger, P. O., Olesen, B. W. & Pederson, C. J. K. 1975. The Mental Performance of Subjects Clothed for Comfort at Two Different Air Temperatures. *Ergonomics*, 18, 359-374.

WINDSOR CONFERENCE 2014

COUNTING THE COST OF COMFORT

WORKSHOP 3

Overheating in buildings

Invited Chair: Fergus Nicol

WINDSOR CONFERENCE 2014

COUNTING THE COST OF COMFORT

THE WORKSHOP PROGRAMME

WORKSHOP 3: Overheating in Buildings

Invited Chair: Fergus Nicol

11th April 2014: 16.30 – 18.30 – Greening Room (2 Hours)

While it is clear that humans are highly adaptable in terms of comfort temperature, and that this should be reflected in the development of guidelines and legislation for acceptable temperature bands in a given location, it is paramount to consider the physiological limits of high temperature. The results of even a relatively small increase in core temperature can result in delirium, convulsions and coma, and too high an exceedence of a safe core temperature can be fatal. (Epstein et al. 2004) An adaptive model of thermal comfort may project comfort at surprisingly high temperatures, but it is crucial to include in any model the limits of the physiological adaptability of the human body. Clearly, the point at which the body can no longer regulate a safe temperature should be the absolute limit in any situation, regardless of projected thermal comfort level at that temperature. As temperatures around the world break records, and growing numbers of heat waves are associated with power outages (eg, recently during the record Australian Summer temperatures) the basic assumptions about what are 'normal temperatures' as defined in Guidelines, how hot can it actually get and still be considered comfortable and how can discomfort be alleviated at high temperatures should all be opening discussed, and will be in relation to the presented 3 papers.

Indoor Overheating Risk and Climate Change. Modelling sensitivity of building design parameters for a free-running building.

Linda Gichuyia¹ and Koen Steemers¹

¹ University of Cambridge, Department of Architecture, 1-5 Scroope Terrace Cambridge CB2 1PX. United Kingdom.

Abstract

Central to this study is the significance of making adaptation decisions whose success in achieving resilience to indoor overheating, remain effective both in the short term and long term future. This is in the context of climate change and the varying ranges of uncertain trajectories that may happen during a building's service life in a developing country (Kenya). The study takes a quantified approach to guiding adaptation decisions by using a methodology that allows appraisal of different design options for an extended timescale (1990 to 2100). Seven adaptation interventions relative to achieving thermal comfort in a free-running non-domestic building have been examined, assessed and ranked with respect to their effectiveness for two timescales (1990 and 2080). The results suggest that decision making between the different design measures and adaptation to climate change options can be enhanced by including the effects of potential future conditions. Ultimately, aiding to achieve robust indoor spaces that can anticipate and adjust to overheating.

Keywords: Climate change resilience, Indoor thermal Comfort, Uncertainty Analysis, Sensitivity Analysis, Parametric study.

1. Introduction

Indoor temperatures in free-running buildings are closely linked to the external environment. Given that a warming climate is widely accepted as the most likely impact of climate change in all climates (Roaf et al., 2009), the future will offer greater challenges to indoor spaces aiming to provide passive or low energy comfort cooling. Of even greater concern is the potential warming effects of climate change in tropical climates like in Kenya, where currently, heat, and too much of it, as expressed by Baker (1987) is the dominant factor for comfort.

The inevitable effects of global warming and the premise that buildings have a relatively long lifespan, which could easily reach 50 to 100 years, heightens the need to look towards the future and institute appropriate measures. Building design measures need to ensure that all buildings are future-proofed to reduce their vulnerability to the effects of climate change. This then speaks to the significance of making decisions now, whose success in achieving resilience remain effective with time in the face of a changing climate. Based on this, particular focus has been given to ways of achieving indoor thermal performance over an extended timescale in Kenya's tropical climate in this study.

Passive¹ thermal comfort strategies offer great potential geared towards both Mitigation and Adaptation of buildings to climate change. It is certain that there are quite a number of established passive design strategies geared towards indoor thermal comfort of spaces in the current climate for the many climatic zones in the world. Although, It has been hard to fully answer the question on how effective these different approaches to passive indoor comfort will be in the future presuming that the climate, boundary conditions around the building, the future modification of space and its use in 50-100 years may not remain stationary.

Given this relatively long life-span of buildings, it is becoming increasingly difficult to ignore the need to make design decisions that remain effective throughout the building's life time. Arguably, this cannot happen without having to carry out probabilistic analysis of physical, environmental and socio-economic change over an extended timescale in parallel with an analysis of the life-cycle thermal performance of indoor space.

Especially noteworthy here is that indoor spaces need to remain thermally comfortable and energy efficient both in the short term and long term future while being subjected to many different developments. Wilde & Tian (2009) identify some of these developments to include changing environmental conditions (e.g. climate change and effects of urbanisation), social-economic developments, changes in legislation, and technological advances among others. Arguably therefore, the inherent aspect of predicting future thermal performance of an indoor space is devoted to the idea of the uncertainty that all these developments, some listed above, bring about. Assessing the effects that all these uncertainties have on the thermal performance of an indoor space will undoubtedly aid in understanding and predicting building performance both now and in future leading to effective decision making during the lifecycle of the building be it in early design stage and/or during the building's lifetime.

Decision making is therefore a crucial element in building design and in line with the worsening climate change problem as well as the uncertain socio-economic change over the coming years, the need to capitalize on design measures that are robust to uncertainties and those that remain unaffected with time cannot be overemphasized. However, making decisions comes with the need to justify those decisions rationally. This therefore triggers a few questions some listed here below:

- a. How much evidence does one need to justify certain design actions that affect
 - i. A particular building during design and management of that building in its lifetime?
 - ii. A wide range of buildings that have different character when making policy decisions?
- b. How do we manage to struggle through design decisions in the face of uncertainty?
- c. How do different building types need to adapt to the warming effects of climate change?

Undoubtedly, quantifying the consequences of design actions marks the first step to justifying particular design measures as quantitative evaluation will assist a decision maker to measure the level of achievement of objectives, which in this study's context is limited to advice on managing overheating risk.

¹ The term "Passive design" in this report's context applies to low energy design achieved not by electromechanical means, but by the building's particular morphological organisation to enable the indoor temperature of the building to be modified through natural and ambient energy sources in the natural environment. (Yeang 1999, p.202)

Based on this background, the focus underlying this study includes:

- a. To present a software supported approach that reflects indoor overheating risk as an effect of climate change, socio economic change and uncertain variability of building related factors that affect indoor thermal performance of office spaces in Kenya's tropical climate.
- b. By using long-term climatic and socio-economic scenarios to quantify indoor overheating risk for the period ranging between the current climates to the year 2100, in order to demonstrate how overheating risk evolves through time and how the various design measures respond to this risk.
- c. Mapping out the consequences of dealing with a whole range of uncertainties in the specific case of predicting overheating risk is undertaken to examine the different design measures relative to achieving thermal comfort, to assess and ultimately rank them with respect to their effectiveness and their urgency levels in the building's lifetime.
- d. This is with the premise that the results from this study will in turn help to support decision making process by providing a basis to compare different design measures, ultimately leading to an improved guidance in the design process and use of the building both now and in the future.

2. Overheating Risk and its significance in a changing climate

As defined in ISO Guide 73, risk is the “effect of uncertainty on objectives” (ISO, 2009) and is composed of three main elements: Vulnerability, Exposure and Hazard (Ale, 2009). The concept of risk combines an understanding of the likelihood of a hazardous event occurring with an assessment of its impact and mostly presented as the equation:

$\text{Risk} = \text{Hazard} \times \text{Elements at Risk} \times \text{Vulnerability}$ (Ale, 2009).

Therefore, in the context of indoor overheating,

- Hazard: presents potential threat of the effects a warming climate in uncertain future;
- Elements at risk: presents the building related features that affect indoor thermal performance
- Vulnerability presents exposure and susceptibility of the indoor environment.

Hence, the total overheating risk may be decreased by reducing the size of any one or more of the three contributing variables listed above. This point is sustained by Roaf et al. (2009) when they write that “Our exposure to risk caused by climate change will depend on where that building or that infrastructure is in relation to the hazards perpetrated on us by the changing climate”.

A slightly different definition of risk but with a similar approach as Ale, (2009) is one by Crawford-Brown, (1999) and the National Research Council- NRC, (1983). They outline the structure of risk to include: Hazard identification, exposure-assessment, exposure-response assessment and risk characterization in that order. Using their view in the context of indoor overheating and climate change,

- Hazard identification: presents the warming effects of climatic change.
- Exposure assessment: presents how building related factors interact with the changing conditions.
- Exposure-response assessment: presents how the indoor space is affected by this interaction causing changes in probability, severity and variability of overheating effects as a result of the hazard.
- Risk characterization: presents results from the above 3 stages, combined to provide a complete picture of overheating risk including consideration of uncertainty.

Particularly important here is that resilience to overheating risk is therefore about risk characterization, and making decisions that allow the likely overheating effects reduced or managed, and the opportunities to be exploited as summarised by Willows & Connell (2003).

3 The concept of Adaptation as risk management

A dominating method of assessing and managing potential future conditions is the risk approach. As summarised in the book Risk: An Introduction (Ale, 2009), typical risk studies start with a study of probabilities, which is named risk assessment. This is then followed by a study of the consequences, which is named risk analysis. Once both probabilities and consequences are known they are combined into risk quantification. This then can be used to study risk acceptance and risk abatement options under risk management.

Assessment methods for adaptation to climate change are very compatible with environmental risk assessment frameworks (Willows & Connell, 2003), and this has led to Risk management being linked with adaptation for a while now. This is an area that is currently seeing significant development with a few studies beginning to link it to climate change adaptation strategies of the built environment to risk management. For instance, studies by Paul de Wilde and Wei Tian of the University of Plymouth, UK.

Risk quantification and management have been linked to decision making as well. Crawford-Brown, (1999) maintains that it is hard to imagine risk analysis existing without the need for decisions and without the needed for a systematic approach to aiding those who make decisions. Crawford-Brown, (1999), further establishes that: given this close connection to decision making, it is not surprising to find that risk analysis has been infused with methods associated with decision analysis such as uncertainty analysis, variability analysis and sensitivity analysis. These three risk-based/decision analysis methods are very key to achieving this study’s objectives.

4 Methodology

The software supported process underlying the study is detailed in this section and it has been divided into three steps to include: Pre-simulation, Simulation and post-simulation steps as summarized in figure 1 below.

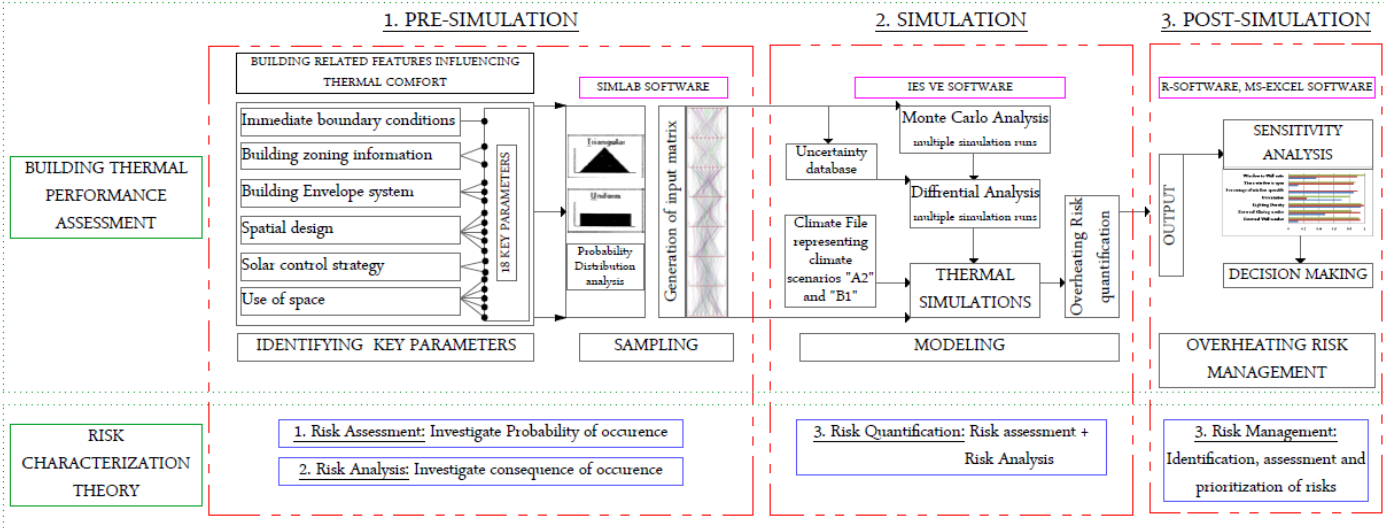

Figure1. An illustration of the methodology procedure used divided in 3 steps: Pre-simulation, Simulation and post-simulation

The pre-simulation stage included risk assessment and risk analysis stages of the risk method adopted. In order to generate realistic scenario spaces that represent Nairobi's non-domestic building stock, an investigation of the parameters under study was carried out including their probabilistic variation over an extended timescale. All input parameters were sampled using the Latin Hypercube Sampling (LHS) method, with the aid of the freeware tool SIMLAB (Saltelli, 2000) to create an input matrix of 80 sample spaces ready for the simulation process. These 80 scenario spaces represent a range of combined building related attributes that are known to have the greatest effect on indoor thermal performance.

The 80 sample scenario spaces were digitally modelled and dynamically simulated using IES VE, a building simulation software, to quantify the indoor overheating effect of climate change for the timescales investigated. This was then followed by Uncertainty analysis, that was carried out using the Monte Carlo Analysis method to quantify the overheating effects under realistic parameter variation.

The final stage, the post-simulation stage, included the risk management stage of the study. Sensitivity analysis was undertaken to rank the parameters investigated in order of their importance/influence to overheating risk. In the end, this will aid in prioritization of the most effective interventions that were effective both in the short term and long-term future.

The following sections further illustrate the three main processes discussed above and the steps underlying the implementation of the sampling-based uncertainty and sensitivity analysis method used.

- i. Pre-simulation:
 - a. Definition of the prototype building model
 - b. Parameters investigated
 - c. Variability Analysis
 - d. Generation of the input matrix
- ii. Simulation:
 - a. Software used
 - b. Climatic data used
 - c. Overheating Risk Index
 - d. Uncertainty Analysis
- iii. Post-simulation
 - a. Sensitivity Analysis
 - b. Overheating Risk Management

4.1 Pre-Simulation

a. Prototype building model

It is important that the prototype model represents all essential features of a building to include the characters of the building envelope system (i.e. physical dimensions and construction material properties), building zoning information, features of internal load (including occupancy, lighting and equipment use), and design parameters/strategies that control cooling of spaces.

The prototype building model used in this study was a square plan illustrated in figure 2 below. The prototype space is the one highlighted in a deeper shade and is of 4m x 6m in dimension. The underlying motivation for such a space was one that could be easily modified to pick out the characteristics of parameters under investigation while at the same time,

remaining isolated from the influences of other factors during the thousands of thermal simulations performed.

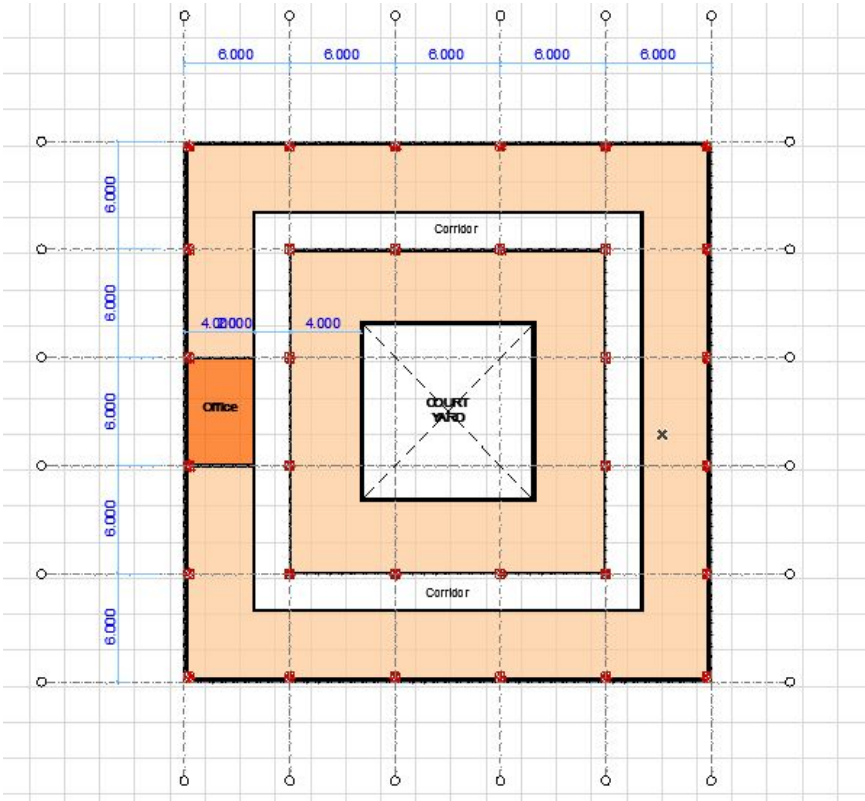

Figure 2. Floor plan of the prototype building used in this study.

b. Parameters investigated:

The building features and parameters investigated and are listed in the table 1 below.

Table 1. List of building related features and variables being investigated

BUILDING FEATURES	PARAMETERS
Immediate boundary condition	Urban Obstruction (context)
Building zoning information	Floor plate orientation
	Floor plate zone
Design	Natural ventilation strategy
	Floor to Ceiling height
	Room Depth (room height to depth ratio)
Building envelope system/Design	Window to wall ratio
	Percentage of window openable
	Glazing type U-Values
	External wall U-Values
	Thermal mass of the walls
Solar control strategy	External Solar Shading
	Internal Blinds
Use of space	Occupant density
	Equipment density
	Lighting density
	Time windows are open
	Working hours

c. Variability Analysis

A study of the possible variability of the parameters listed in Table 1 above was undertaken, as a first step towards creating a heterogeneous sample of indoor scenario spaces that represents Nairobi's non-domestic building stock. Variability analysis was mostly informed by the existing modes in Nairobi and from literature, in order to derive data distribution that realistically represents the parameters' true nature. Table 2 summarizes this and presents the probability distributions of each parameter within fixed extreme minimum and maximum values of possible variations or design options. Most parameters assume continuous probability distributions within the fixed extreme values to illustrate the equal possibility of each option's likeliness to happen in Nairobi's urban context. Parameters including occupant density, equipment density and lighting density have triangular probability distribution to illustrate that the extreme limits have a lower chance of happening with the middle value having the highest probability of happening, as informed by standard views.

Table 2. List of parameters being investigated indicating their data distribution patterns.

	PARAMETERS	DISTRIBUTION	MIN. VALUES	MAX. VALUES	UNITS
External Boundary	Urban Obstruction	Uniform discrete	Point in space	Dense urban grid	See table 3
Early Design	Natural ventilation strategy	Uniform discrete	See table 3	See table 3	See table 3
	Floor plate orientation	Uniform continuous	0	360	degree
	Floor plate zone	Uniform discrete	ground floor	50th floor	floor level
Management/Innovation technologies/Renovation	Window to wall ratio	Uniform continuous	0	100	%
	External wall U-Values	Uniform discrete	0.1996	8.9	W/m ² K
	Internal wall U-Values	Uniform discrete	Open plan	3	W/m ² K
	Glazing type U-Values	Uniform discrete	1.006	6.1	W/m ² K
	Ceiling/Floor U-Values	Uniform discrete	0.6	5.36	W/m ² K
	External Solar Shading	Uniform discrete	No shading	See table 3	See table 3
	Area of window openable	Uniform continuous	0	100	%
	Floor to Ceiling height	Triangular	2.1	15	metres
The Use of space/Internal Heat Gains	Occupant density	Triangular	20	1	m ² /person
	Equipment density	Triangular	2	30	W/m ²
	Lighting density	Triangular	1	20	W/m ²
	Time windows are open	Uniform discrete	Never	All day	See table 3

Table 3. List List of parameters being investigated indicating their uncertainties in design options and use of the spaces.

Ventilation Strategy	Time when windows are open	Urban Obstruction	Floor to ceiling Height	External Shading
Single sided	Never	Dense- with high-rise (City terrain)	2.1m	No Shading
Stack Ventilation	0hrs - 24hrs	Dense- with low-rise buildings(City terrain)	3m	Vertical shading 0.75m deep
Cross Ventilation	0hrs - 12hrs	Sparse- with high-rise (Country terrain)	4.5m	Vertical shading 1.5m deep
	12hrs - 24hrs	Sparse- with low-rise buildings (country terrain)	9m	Horizontal shading 0.75m deep
	8hrs - 18hrs	Point in space (suburbs terrain)	10.5m	Horizontal shading 1.5m deep
	18hrs - 8hrs		12m	Vertical + Horizontal shading 0.75m deep
			13.5m/15m	Vertical + Horizontal shading 1.5m deep

d. Generation of input matrix

This step in pre-simulation involved the generation of sample scenario spaces to act as input data during the simulation stage. In order to explore both the high to low possibilities of exposure to the overheating effects of climate change, as well as varied exposure-response possibilities, sample spaces that present inter-parametric variability of options listed in table 2 and 3 were prepared. 80 different scenario spaces were generated using the Latin Hypercube test sampling method embedded in Simlab software. A detailed description of the workings of Simlab software is given by Giglioli & Saltelli, (2000). The Latin Hypercube test sampling method was used for generating samples with plausible collections of parameter values from a multidimensional distribution (McKay & Beckman, 1979). The number of sample spaces is 80, which is not an arbitrary number but was informed by previous uncertainty and sensitivity analysis studies undertaken. Macdonald (2002) and Lomas & Eppel (1992) assert that independent of the number of variables considered, the reliability of results from Uncertainty and Sensitivity Analysis does not increase after 60 to 80 sample simulations as illustrated in figure 3 below.

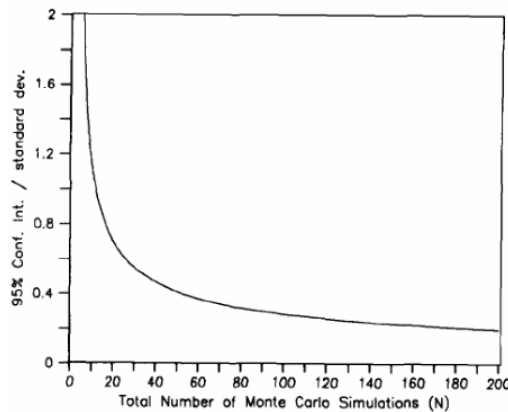
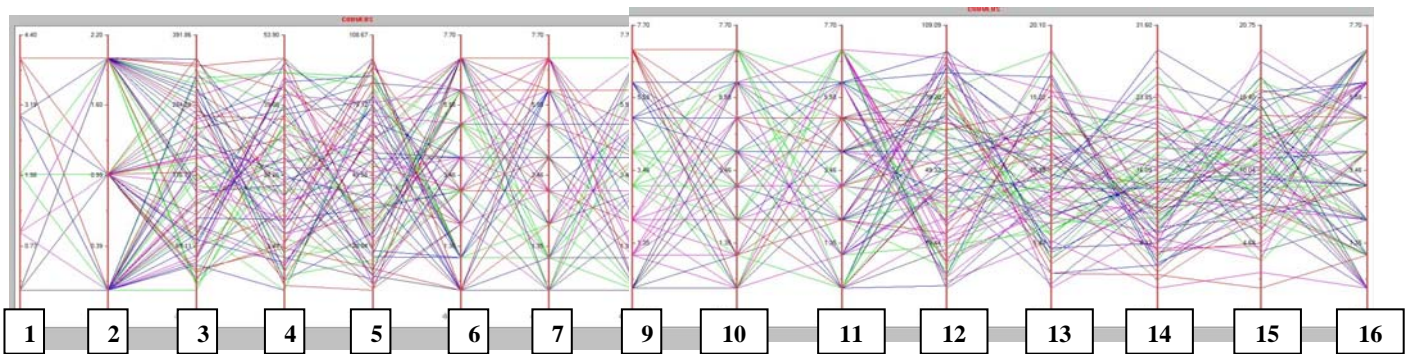

Figure 3 Reliability of the total number of Monte Carlo Analysis simulations (Hopfe, 2009)

80 scenario sample spaces present a confidence interval of at least 95% as illustrated in figure 3 above. Figure 4 illustrates the input matrix of data for the 80 sample spaces generated, and demonstrates their inter-parametric combinations.



KEY

1	Urban Obstruction	7	Internal wall U-Values	13	Occupant density
2	Natural ventilation strategy	8	Glazing type U-Values	14	Equipment density
3	Floor plate orientation	9	Ceiling/Floor U-Values	15	Lighting density
4	Floor plate zone	10	External Solar Shading	16	Time windows are open
5	Window to wall ratio	11	Percentage of window openable		
6	External wall U-Values	12	Floor to Ceiling height		

Figure 4 . Generated Input Matrix illustrating inter-parametric relationships of the combined building related attributes being investigated.

4.2 Simulation

The second step of the process (figure 1) involved digitally modeling the 80 scenarios spaces identified in section 4.1 above, by quantifying their overheating risk levels while taking into account their uncertainties. Discussed here below is the building simulation tool and climatic data used to model thermal performance, the overheating risk index used to quantify indoor overheating levels and lastly, the methods used for to quantify uncertainty.

a. Software used:

IES-VE², a dynamic building energy simulation software was used to perform thermal simulations. It consists of a suite of integrated analysis tools, which can be used to investigate the performance of a building either retrospectively or during the design stages of a construction project³. Climatic data for the climate scenarios under study was input in the IES VE software to perform indoor temperature analysis for each model. The software calculated indoor temperatures for one design day for each month in a year. This study's results present average indoor temperature data calculated for Monday (24hrs) for all months in the respective climate scenario year bands modelled.

b. Climatic Data used:

The GCM (Global Climatic Model) data for Nairobi was downloaded directly from the IPCC⁴ Data Distribution Website⁵. Given that GCMs are only accurate at continental scales and larger, and have a typical resolution of 300km x 300km, downscaling was necessary to achieve higher spatial and temporal resolution climatic data of a resolution of 25km x 25km. Morphing method, a type of time series adjustment was used to downscale GCMs in this study. Developed by Belcher, Hacker, & Powell (2005), this method has already been successfully used to prepare weather data for future energy and thermal performance simulation in these studies: (Jentsch, 2009; Gul et al., 2012; Kershaw et al., 2010; Wilde & Tian, 2009; Smith & Hanby, 2012; Jenkins et al., 2008; Porritt et al., 2012) among others. It is a method that is utilised as a baseline for transforming current Test Reference Years (TRY)⁶ into climate change weather years. The detailed procedure of calculations can be found in: (Belcher et al., 2005; Jentsch et al., 2008; CIBSE, 2009).

c. Overheating risk index:

The degree-hour criterion (Carlucci & Pagliano, 2012), which is a cumulative index was used to quantify the annual accumulation of thermal stress for each scenario space investigated per climate scenario. This is by calculating the amount by which the operative temperature⁷ for every given hour in a year (8760 hrs) exceeds the Adaptive comfort temperature. The adaptive comfort temperature is calculated using the Humphreys thermal neutrality formulae⁸ for free running buildings. The hourly values of indoor temperature above the thermal comfort levels are than calculated per hour for each day and the net value of thermal discomfort in °C hours (°C h) calculated for the 8760 hours in a typical year.

2 Virtual Environment by Integrated Environmental Solutions

3 An overview of IES VE software is given online in :<http://www-embp.eng.cam.ac.uk/software/iesve> (Accessed January 2014)

4 Intergovernmental Panel on Climate Change

5 www.ipcc-data.org

6 Defined as a whole calendar year, which can be used to represent the recorded weather patterns for a long term period (10 to 40 years) at the given location.

7 Operative temperature is the average of the air temperature and the room surface temperatures.

8 Humphreys (1978) examined a large number of comfort studies, correlated thermal neutrality with the prevailing climate, and for free-running buildings suggested the equation $T_n = 11.9 + 0.534 T_{o.av}$ (where $T_{o.av}$ is the month's mean outdoor temperature), thus laid the foundation of the adaptability model. Source: Szokolay- 2004, p.20

d. Uncertainty analysis:

To account for uncertainty in the inputs simulated, two established methods of quantifying uncertainty analysis were used: i.e. the Monte Carlo analysis and the Morris Method of differential analysis in that order as discussed below.

i. Monte Carlo Analysis (MCA)

MCA is a method used to analyze and quantify the approximate distribution of possible results on the basis of probabilistic inputs, which in this case represents the the 80 sample spaces identified in 4.1 above. The samples are individually simulated using IES VE for each of the four different timescales (base year 1990, A2-2020, A2-2050, A2-2080) investigated. Total annual overheating levels were quantified for each sample using the overheating risk index method defined above. The results are as illustrated in figure 5.

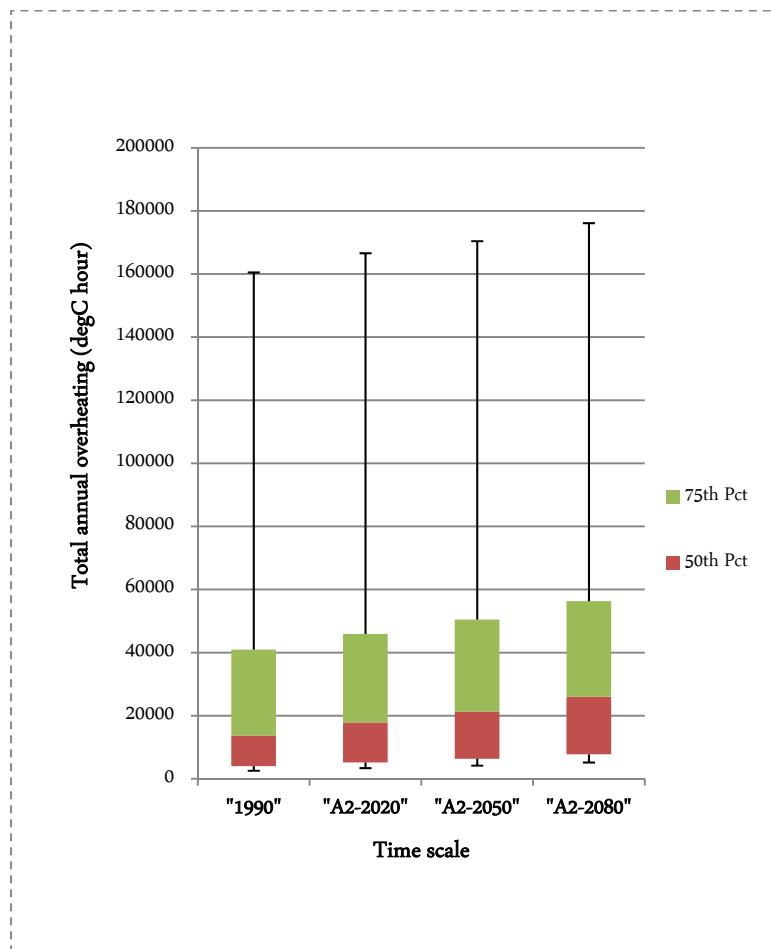

Figure 5. Monte Carlo Analysis results for four timescales.

ii. Morris Method

In the second stage of uncertainty analysis, each input parameter was varied over the whole range of their possible values while the remaining parameters stayed identical at their 'base-case' using the Morris method (Morris, 1991) of quantifying uncertainty.

For this study, only 7 out of the 18 parameters listed in table 1 were investigated and they include: External wall u-value, External glazing u-value, Lighting density, Orientation, Percentage of window openable, time the window is open and the window to wall ratio parameters.

The steps taken to carry out the Morris method are outlined here below:

- a) The first step starts with the sampling of a set of values within the defined ranges of possible values for each input parameter and variables investigated. 5-6 values of the variables are selected within the extreme limits as listed in the table 4 below. 5-15 values are required to effectively simulate the “One-at-a-time” differential analysis out as outlined by Morris, (1991), and other studies (Saltelli, et al., 2004).

Table 4. Variables simulated for the 7 parameters investigated in this study

PARAMETERS	UNITS	RANGE OF VARIABLES INVESTIGATED					
External Wall u-value	W/m ² K	"5.6472"	"4.0816"	"3.5361"	"2.2878"	"0.1996"	"0.1"
External Glazing u-value	W/m ² K	"4.2207"	"3.1641"	"2.4115"	"2.1381"	"1.7049"	"1.0077"
Lighting Density	W/m ²	"0"	"4"	"8"	"12"	"16"	"20"
Orientation	degrees	0 (W)	180 (E)	45 (SW)	135 (SE)	225 (NE)	90 (S)
Percentage of window openable	%	0pc	25pc	50pc	75pc	100pc	
Time window is open	24	on cont.	6am - 10pm	8am - 6pm	9pm - 9am	0	
Window to Wall ratio	%	0pc	25pc	50pc	75pc	100pc	

- b) The second step involves changing the values of one variable at a time while all other parameter values remain at their start values and the resulting change in overheating outcome is calculated. In total, the number of simulation runs for each time scale simulated in this case was: $80 \times 39 = \mathbf{3120}$. Only two timescales were simulated base year-1990 and A2-2080 in this study. The results are as summarized in figure 6.

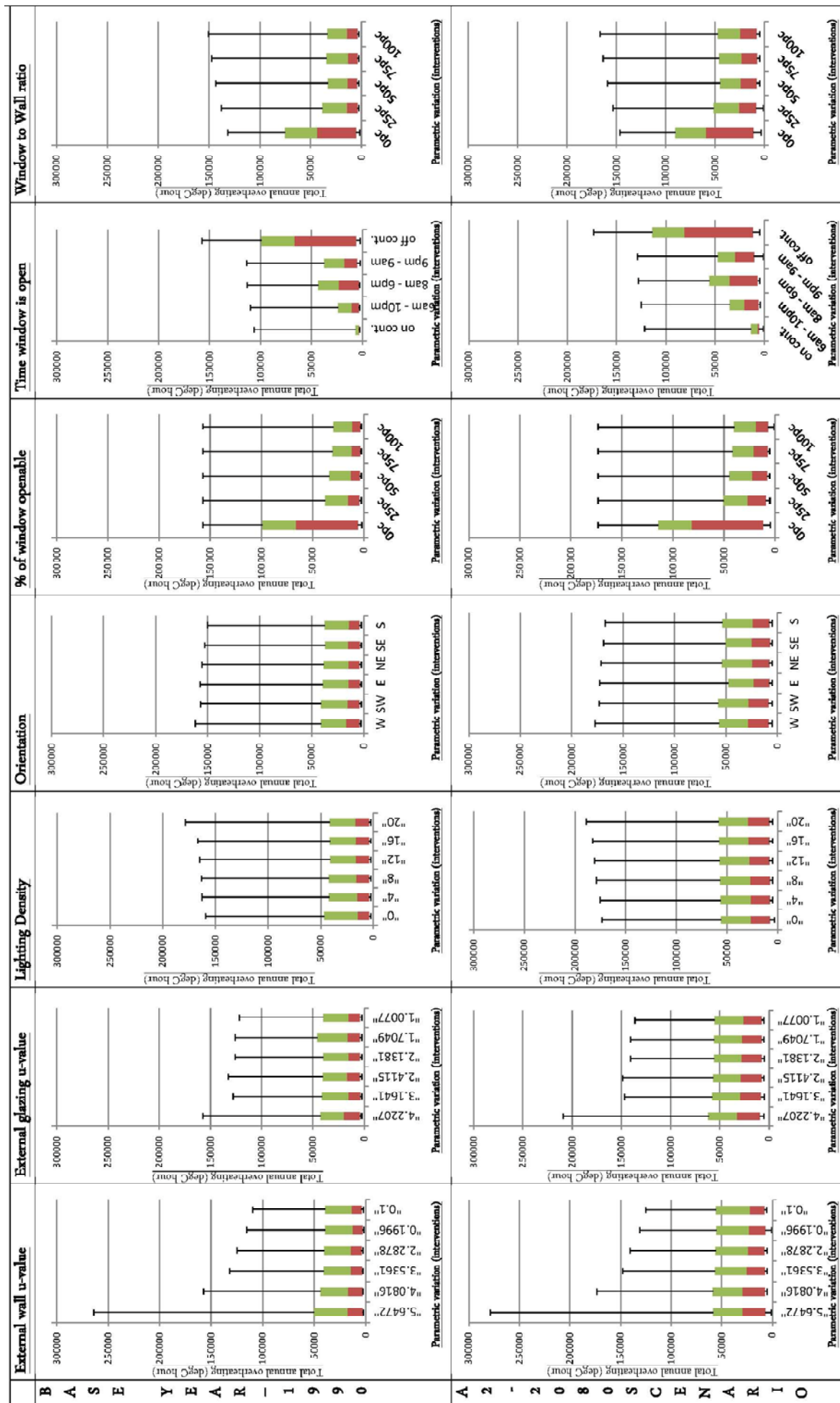

Figure 6. Box and whisker plots illustrating predicted annual overheating levels of the seven design interventions investigated for the 1990 and A2-2080 climate scenarios.

4.3 Post Simulation

This final stage involved calculating sensitivity in order to determine the contributions of each of the 7 individual parameters investigated to indoor overheating risk.

a. Sensitivity calculations

Sensitivity has been defined as “the study of how the variation/uncertainty in the output of a mathematical or statistical model or system (numerical or otherwise) can be apportioned, qualitatively or quantitatively to different sources of uncertainty/variations in its inputs” (Saltelli, et al. 2008) This simply means the influence on variation of the output by the input (Burhenne et al., 2010). There are several approaches to calculate sensitivity as summarized in table 5 below:

Table 5 A summary of some of the methods used to determine sensitivity, summarised by Helton, Johnson, Sallaberry, & Storlie, (2006)

Method used to Determine Sensitivity	Brief description (x_j - input distribution; y -output)	Example
Correlation	Provides a measure of the strength of the linear relationship between x_j and y	-Pearson correlation coefficient (PCC)
Regression Analysis	Provides an algebraic representation of the relationships between output and one or more of the input variables.	-R squared (R^2) -Standardized Regression Coefficients (SRCs)
Partial Correlation	The PCC characterizes the linear relationship between x and y after a correction has been made for the linear effects on y of the remaining elements of x , and the SRC characterizes the effect on y that results from perturbing x_j by a fixed fraction of its standard deviation	Partial Correlation Coefficient (PCC) <i>(PCCs and SRCs provide related, but not identical, measures of variable importance).</i>
Rank Transformations	A rank transformation can be used to convert a nonlinear but monotonic relationship between the x_j and y into a linear relationship. With this transformation, the values for the x_j and y are replaced by their corresponding ranks.	-Rank (i.e., Spearman) Correlation Coefficients (RCCs), -Rank Regression Coefficients (RCCs) -Standardized Rank Regression Coefficients (SRRCs) - Partial Rank Correlation Coefficients (PRCCs).

In this study, standardized regression coefficients (SRCs) are used for sensitivity analysis calculations. It is a quantitative measure of sensitivity based on regression analysis and is used to provide a useful measure of variable importance for independent variables. Higher absolute values of SRCs mean that the corresponding variables are more important. Negative values of SRCs indicate that the input and output variables tend to move in opposite directions (Helton et al. 2006). The sensitivities of each of the seven variables is calculated for all the 80 sample spaces for the two timescales investigated, as well as the Mean absolute SRC for each variable investigated to identify the overall influence of the variables per timescale. The results are as summarised in Tables 6 and 7.

Table 6 Ranking of the 7 single interventions investigated in order of their relative importance for the 80 scenario spaces investigated in the 1990 climate scenario.

SAMPLE SPACE	CURRENT CLIMATE Influence coefficient values and rankings (1 - highest impact and 7 - lowest impact)						
	1	2	3	4	5	6	7
SAMPLE 1	External Wall U-Value	Window to Wall Ratio	Glazing Type	Time window is open	Orientation	Percentage of window openable	Lighting Density
SRC	-0.98952	-0.966671	-0.916098	0.77739	-0.774749	0.207107	-0.456675
SAMPLE 2	Time window is open	Percentage of window openable	Window to Wall Ratio	Lighting Density	Orientation	Glazing Type	External Wall U-Value
SRC	0.881402	-0.786413	-0.793953	0.699932	-0.588687	-0.179144	0.091282
SAMPLE 3	Time window is open	Window to Wall Ratio	External Wall U-Value	Percentage of window openable	Lighting Density	Glazing Type	Orientation
SRC	0.977654	-0.975395	-0.974261	-0.841722	0.799886	0.269063	-0.629883
SAMPLE 4	Window to Wall Ratio	Glazing Type	Time window is open	Lighting Density	External Wall U-Value	Orientation	Percentage of window openable
SRC	0.99983	-0.970578	0.913009	0.88886	-0.776824	-0.463634	0
SAMPLE 5	Lighting Density	Time window is open	Window to Wall Ratio	Percentage of window openable	Orientation	External Wall U-Value	Glazing Type
SRC	0.889925	0.864396	-0.72323	-0.718791	-0.684394	-0.666636	0.252399
SAMPLE 75	Time window is open	Lighting Density	Window to Wall Ratio	Percentage of window openable	Orientation	External Wall U-Value	Glazing Type
SRC	0.92894	0.89969	-0.897899	-0.824909	0.76216	0.684497	0.289954
SAMPLE 76	Glazing Type	External Wall U-Value	Time window is open	Window to Wall Ratio	Percentage of window openable	Lighting Density	Orientation
SRC	-0.984619	-0.942227	0.872427	-0.744676	-0.723029	0.699987	-0.629875
SAMPLE 77	External Wall U-Value	Orientation	Glazing Type	Time window is open	Percentage of window openable	Window to Wall Ratio	Lighting Density
SRC	-0.973479	-0.94463	-0.828943	0.828644	-0.799943	-0.787887	0.666999
SAMPLE 78	Window to Wall Ratio	Percentage of window openable	Lighting Density	Time window is open	Glazing Type	External Wall U-Value	Orientation
SRC	-0.98628	-0.810025	0.703995	-0.284141	-0.271058	0.176463	-0.073716
SAMPLE 79	Orientation	Glazing Type	Time window is open	Lighting Density	Window to Wall Ratio	External Wall U-Value	Percentage of window openable
SRC	-0.921829	-0.900644	0.899824	0.899983	-0.862874	-0.823288	-0.786007
SAMPLE 80	External Wall U-Value	Glazing Type	Time window is open	Window to Wall Ratio	Lighting Density	Percentage of window openable	Orientation
SRC	-0.955272	-0.916119	0.910563	-0.886691	0.779973	-0.259766	-0.491676
SUMMARY INFLUENCE RATING AND RANKING OF THE SEVEN PARAMETERS (1 - highest impact and 7 - lowest impact)							
	1	2	3	4	5	6	7
ABSOLUTE MEAN SRC	Time window is open 0.822988	Window to Wall Ratio 0.80656088	Lighting Density 0.7497943	Orientation 0.73908975	External Wall U-Value 0.6561748	Percentage of window openable 0.6554175	Glazing Type 0.56882975

Table 7. Ranking of the 7 single interventions investigated in order of their relative importance for the 80 scenario spaces investigated, in the A2-2080 climate scenario.

SAMPLE SPACE	A2-2080 CLIMATE Influence coefficient values and rankings (1= highest impact and 7 = lowest impact)						
	1	2	3	4	5	6	7
SAMPLE 1	External Wall U-Value	Glazing type	Time window is open	Window to Wall Ratio	Lighting Density	Orientation	Percentage of window operable
SRC	-0.98128	-0.82796	0.81795	-0.766387	-0.44332	-0.536958	0
SAMPLE 2	Time window is open	Percentage of window operable	Window to Wall Ratio	Lighting Density	Glazing type	External Wall U-Value	Orientation
SRC	0.824627	-0.824015	-0.724923	0.699998	-0.394001	-0.099684	-0.066344
SAMPLE 3	Time window is open	Window to Wall Ratio	External Wall U-Value	Glazing type	Percentage of window operable	Lighting Density	Orientation
SRC	0.981328	-0.975163	-0.973742	-0.914392	-0.824726	0.799889	0.997066
SAMPLE 4	Window to Wall Ratio	Glazing type	Time window is open	Lighting Density	External Wall U-Value	Orientation	Percentage of window operable
SRC	0.99979	-0.947118	0.936661	0.89764	-0.78988	-0.379494	0
SAMPLE 5	Lighting Density	Time window is open	Window to Wall Ratio	Percentage of window operable	Orientation	External Wall U-Value	Glazing type
SRC	0.89998	0.87372	-0.72482	-0.718646	-0.66692	-0.61379	-0.451379
SAMPLE 75	Time window is open	Window to Wall Ratio	Percentage of window operable	Lighting Density	Orientation	Glazing type	External Wall U-Value
SRC	0.972859	-0.915428	-0.909587	0.899995	0.874982	-0.30676	0.138723
SAMPLE 76	External Wall U-Value	Glazing type	Time window is open	Window to Wall Ratio	Percentage of window operable	Lighting Density	Orientation
SRC	-0.949778	-0.929753	0.882836	-0.787046	-0.744683	0.699995	-0.678322
SAMPLE 77	External Wall U-Value	Orientation	Time window is open	Window to Wall Ratio	Glazing type	Percentage of window operable	Lighting Density
SRC	-0.97586	-0.96611	0.84429	-0.839687	-0.830882	-0.812858	0.666999
SAMPLE 78	Window to Wall Ratio	Time window is open	Percentage of window operable	Lighting Density	Orientation	Glazing type	External Wall U-Value
SRC	-0.928745	0.94658	-0.820768	0.763996	0.440323	-0.347223	-0.331714
SAMPLE 79	Orientation	Time window is open	Lighting Density	Window to Wall Ratio	External Wall U-Value	Percentage of window operable	Glazing type
SRC	-0.917784	0.897728	0.899996	-0.874033	-0.848212	-0.820135	0.94822
SAMPLE 80	External Wall U-Value	Percentage of window operable	Time window is open	Window to Wall Ratio	Glazing type	Orientation	Lighting Density
SRC	-0.977946	0.921282	-0.891887	-0.891887	-0.811624	0.827181	0.799999
SUMMARY INFLUENCE RATING AND RANKING OF THE SEVEN PARAMETERS (1= highest impact and 7 = lowest impact)							
1	2	3	4	5	6	7	
Time window is open	Window to Wall Ratio	Glazing type	Lighting Density	Orientation	External Wall U-Value	Percentage of window operable	
0.833430625	0.806384725	0.7582888	0.732755987	0.707348213	0.676531288	0.653811913	

b. Overheating risk management

This is the final and most important stage in this study. It seeks to capitalize on the quantitative information of the Uncertainty and Sensitivity Analysis carried out, in order to make a case for decision making and action. Table 8 below illustrates the overall ranking of the 7 parameters investigated by their relative importance to overheating risk for each timescale investigated. It should be noted here that each of the 80 scenario spaces had a different set of parameter ranking as illustrated in table 6 and 7. Table 8 shows their mean sensitivities for each climate scenario investigated. The parameters that ranked the highest need deeper consideration to make a building more robust and/or adaptable to the future conditions.

Table 8. Overall ranking of the 7 single interventions investigated in order of their relative importance to reducing overheating risk for the two timescales investigated.

COMPARATIVE ANALYSIS			
RANK	1990-Parameter	RANK	A2-2080 -Parameter
1	Time window is open	1	Time window is open
2	Window to Wall Ratio	2	Window to Wall Ratio
3	Lighting Density	3	Glazing type
4	Orientation	4	Lighting Density
5	External Wall U-Value	5	Orientation
6	Percentage of window openable	6	External Wall U-Value
7	Glazing type	7	Percentage of window openable

5 Summary of results

A methodology to carry out probabilistic prediction of annual overheating levels in the long term future has been outlined. In addition to taking into account the possible variation of building related features during the building’s service life, this approach accommodates appraisal of different single design interventions in the context of climate change for an extended timescale (1990 to 2100). This is with the main aim of identifying what single intervention is most effective in reducing indoor overheating risk in a free running buildings in Nairobi’s tropical climate. The results illustrate three key issues being investigated:

- a. The effect of climate change on a range of combined building related attributes that are known to have the greatest effect on indoor thermal performance as represented by the 80sample spaces. The Monte Carlo Analysis (MCA) results summarised in figure 5 illustrates how the annual overheating risk levels of these 80 sample spaces evolves through the different time scales investigated i.e 1990, 2020, 2050 and 2080.
- b. Secondly, the results illustrate the effect of seven single interventions (i.e by varying: External wall u-value, External glazing u-value, Lighting density, Orientation with respect to the sun-path, Percentage of window openable, Time the window is open and the Window to wall ratio) on the 80 sample spaces in the years 1990 and 2080 as illustrated in graphs in figure 6.
- c. Thirdly, the effectiveness of these seven interventions has been assessed and ranked in order of their exposure-response to overheating risk for the two time scales investigated (1990 and A2-2080) summarised in Table 8.

6 Conclusion

This study presents preliminary results of an on-going research that seeks to investigate the impacts of design and user choices on indoor thermal comfort for free-running office buildings in Kenya. This is with an aim to improve guidance on design decision making in a changing climate. Within the limited scope of this study, the results suggest that some interventions cause a greater variation to overheating risk levels than others. Out of the seven single passive interventions investigated, one would achieve greater reductions in annual overheating levels by changing the time the windows are open followed by reducing its window to wall ratio for both 1990 and 2080 timescales. The rankings of the other 5 parameters investigated vary between the 1990 and the A2-2080 climate scenarios, which is an indicator that effectiveness of some design options and interventions vary with time.

In conclusion, the importance of taking into account the performance of an indoor space and its components under potential future conditions has the capacity to support whole-life climate sensitive design. This is by supporting decision making between different design measures and adaptation to climate change options either during design, during the building's use, and its possible modifications in the future, to provide comfortable conditions and reduce energy demand during the building's service life.

Overall, the results of a risk management approach to adaptation of buildings to climate change will undoubtedly aid in identifying of potential routes towards energy efficiency along a time axis. This will aid in the setting of building regulations, policy strategies and updated building codes which improve buildings' effectiveness and ensure that they are future proofed against runaway climate change.

References

- A. Saltelli, Marco Ratto, Terry Andres, Francesca Campolongo, Jessica Cariboni, Debora Gatelli, Michaela Saisana, S. T. (2008). *Global Sensitivity Analysis*. Wiley-Blackwell.
- A. Saltelli, Stefano Tarantola, Francesca Campolongo, M. R. (2004). *Sensitivity Analysis in Practice: A Guide to Assessing Scientific Models*. Wiley-Blackwell.
- Ale, B. (2009). *Risk: An Introduction: The Concepts of Risk, Danger and Chance*. Routledge.
- Baker, N. (1987). *Passive and low energy building design for tropical island climates*. The Commonwealth Secretariat.
- Belcher, S., Hacker, J., & Powell, D. (2005). Constructing design weather data for future climates. *Building Services Engineering Research and Technology*, 26(1), 49–61.
- Burhenne, S., Jacob, D., & Henze, G. P. (2010). *Uncertainty analysis in building simulation with monte carlo techniques* Institute for Solar Energy Systems , Freiburg , Germany.
- Carlucci, S., & Pagliano, L. (2012). A review of indices for the long-term evaluation of the general thermal comfort conditions in buildings. *Energy and Buildings*, 53, 194–205.
- CIBSE. (2009). *Use of Climate Change Scenarios for Building Simulation: The CIBSE Future Weather Years*. London CIBSE.
- Crawford-Brown, D. (1999). *Risk-based environmental decisions: Methods and culture*. Kluwer Academic Publishers.

- Giglioli, N., & Saltelli, A. (2000). *SimLab 1.1, Software for Sensitivity and Uncertainty Analysis, tool for sound modelling, 11*. Discrete Mathematics.
- Helton, J. C., Johnson, J. D., Sallaberry, C. J., & Storlie, C. B. (2006). *Survey of Sampling-Based Methods for Uncertainty and Sensitivity Analysis*, Reliability engineering and systems safety.
- Hopfe, C. (2009). *Uncertainty and sensitivity analysis in building performance simulation for decision support and design optimization*. Ph.D Thesis, Technische Universiteit Eindhoven.
- ISO. (2009). ISO 31000. *International Organization for Standardization*. Retrieved Jan 10, 2014, from http://en.wikipedia.org/wiki/ISO_31000
- Jenkins, D., Liu, Y., & Peacock, a. D. (2008). *Climatic and internal factors affecting future UK office heating and cooling energy consumptions*. *Energy and Buildings*, 40(5), 874–881.
- Jentsch, M. F. (2009). *Viability of naturally ventilated buildings in the UK under predicted future summer climates*. Ph.D Thesis, School of Civil Engineering and the Environment, University of Southampton.
- Jentsch, M. F., Bahaj, A. S., & James, P. A. B. (2008). *Climate change future proofing of buildings—Generation and assessment of building simulation weather files*. *Energy and Buildings*, 40(12), 2148–2168.
- Lomas, K. J., & Eppel, H. (1992). *Sensitivity analysis techniques for building thermal simulation programs*. *Energy and Buildings*, 19, 21–44.
- M. D. McKay, R. J. Beckman, W. J. C. (1979). *A Comparison of Three Methods for Selecting Values of Input Variables in the Analysis of Output from a Computer Code*. *Technometrics: American Statistical Association*, 21(2), 239–245.
- Macdonald, I. A. (2002). *Quantifying the Effects of Uncertainty in Building Simulation*. Ph.D Thesis, University of Strathclyde.
- Morris, M. D. (1991). *Factorial Sampling Plans for Preliminary Computational Experiments*. *Technometrics*, 33(2), 161–174.
- NRC. (1983). *Risk Assessment in the Federal Government: Managing the Process*. (National Research Council, Ed.). John Wiley & Sons.
- Porritt, S. M., Cropper, P. C., Shao, L., & Goodier, C. I. (2012). *Ranking of interventions to reduce dwelling overheating during heat waves*. *Energy and Buildings*, 55, 16–27.
- Roaf, S., Crichton, D., & Nicol, F. (2009). *ADAPTING BUILDINGS AND CITIES FOR CLIMATE CHANGE A 21st Century Survival Guide Second Edition*. Elsevier Ltd.
- Smith, S. T., & Hanby, V. (2012). *Methodologies for the generation of design summer years for building energy simulation using UKCP09 probabilistic climate projections*. *Building Services Engineering Research and Technology*, 33(1), 9–17.
- Thomas Downing, A. Olsthoorn, R. S. J. T. (2002). *Climate, Change and Risk*. Routledge.
- Willows, R., & Connell, R. (2003). *Climate adaptation : Risk , uncertainty and decision-making*. UKCIP Technical report

Case Study: Thermal Comfort in a Water Mist on Hot Summer Days

Craig Farnham and Kazuo Emura

Osaka City University, Dept. of Housing and Environmental Design, Osaka-shi Sumiyoshi-ku, Sugimoto 3-3-138, Japan 588-8585

Abstract:

In a case study on outdoor mist cooling, 141 people attending an open campus event were surveyed over 2 hot summer days. Nozzles mounted on an oscillating fan sprayed about 18L/h of mist with average droplet diameter of 25 μ m. Subjects stood in the misting area where they wished. Time spent in the misting area was recorded. Skin temperature of the forearm and face were taken with IR surface thermometers before entering and after leaving the misted area. Each participant was surveyed for “thermal sensation” on a 9-level scale, and “general comfort” and “feeling of wettedness” on 7-level scales. “Feeling of wettedness” included an additional qualitative parameter of “unpleasant”, “pleasant” or “neither”.

Misting will increase wettedness, but it can feel pleasant. On average, thermal sensation dropped from +2.7 (very hot) to -1.4 (slightly cool) and comfort increased from -1.4 to +1.8. Though wettedness increased from +0.8 to +1.6, the qualitative wettedness parameter changed from 75% unpleasant to 75% pleasant. Skin temperatures dropped an average of 1.1°C on the forearm, and 1.0°C on the face.

Key Words: water mist, evaporative cooling, thermal comfort, fan cooling

1 Introduction

Use of mist evaporative cooling for thermal comfort in outdoor and semi-enclosed spaces is increasing in Japan, yielding temperature reductions on the order of 2 – 3K on hot summer days (Yamada et al. 2006). Simple surveys of comfort and wettedness showed that about 77% of people experienced increased comfort in a misted area (Uchiyama et al. 2008). Evaluation of the cooling effect of a mist is difficult as results often include readings that indicate that sensors near or within the mist tend to read at the wet bulb temperature (Hayashi et al. 1998, Miura et al. 2008, Suzuki et al. 2009).

Most of the evaporative mist sprays in the literature in Japan consist of droplets of average diameter on the order of 10 - 30 microns. The smallest droplets are generated by pneumatic nozzles driven by high pressure air, while 20 micron droplets can be generated by hydraulic nozzles driven by high-pressure water pumps. The energy consumed by hydraulic spray nozzles is usually lower than air-driven, but at the cost of larger droplets which evaporate more slowly, making wetting of surfaces more likely.

In addition to improved thermal comfort, evaporative cooling mists could be a preventive measure against heat-related illness. Water mists are recognized as a valid emergency medical treatment for heat stroke (Biddinger, 2002). Yet spraying a localized cooling water mist only on the face for comfort has been found to yield no change in core body temperature (Brisson et al., 1989).

The above misting experiments in Japan all involved free falling mist from nozzles set above the target area to be cooled. Placement and control of the spray is designed to limit wetting of the ground and surfaces. However, this results in relatively thin mist such that the measured temperature drops in the zone of human activity may be only 1 – 3K. If the mist is more dense, wetting of surfaces will more likely occur and could be unpleasant. Combination of a fan with mist nozzles could improve thermal comfort on hot days better than either method on its own. The forced convection of the fan that helps cool people will also help speed evaporation of mist droplets that have adhered to skin and clothing. A detailed investigation of a fan and mist cooling system for thermal comfort on hot summer days is needed. A model for thermal comfort improvement due to use of mist fans is also needed to aid in system design and use.

2 Theory

Small mist droplets cool rapidly from the source temperature to about the wet bulb temperature and an individual droplet evaporation rate can be expressed as directly proportionate to the wet bulb depression. (Pruppacher, 1997) In the case of 25 micron scale droplets in typical atmospheric conditions, the change takes a few milliseconds, while the droplets decelerate almost instantly to near zero relative velocity to surrounding air, taking about 50 milliseconds as determined by iterative calculations outlined by Chaker (2002) and Holtermann (2003).

The mist “cone” as a whole will evaporate away in proportion to the time, and therefore distance, traveled. Finely sprayed mist, such as used here, were found to evaporate in proportion to the wet bulb depression in earlier research (Farnham, 2009). During the experiments here, the wet bulb depression was about 8K, as calculated using approximations from the HASP/ALCD (JAMBEE,1992).

2.1 Thermal comfort

Thermal comfort and means to calculate indices such as PMV and PPD are explained in detail in the ASHRAE Handbook – Fundamentals. Key concepts important to the use of mist evaporation include:

- The theoretical cooling limit of sweating at maximum sweat rate with good evaporation conditions is about 675W/m^2 . (Compare this to the potential evaporative cooling of impacting mist, which with this misting fan may exceed 1000W/m^2 if the mist can evaporate completely)
- “Skin temperature is the best single index of thermal comfort.”
- When in a state of thermal discomfort, any move away from thermal stress is perceived as pleasant during the transition.

Mist cooling has the potential to cool the body much more effectively than even the maximum possible natural sweat rate. A difficulty with the ASHRAE standard models is the version in the 2005 handbook is designed only for air velocities much lower than from this fan. Equations for the convection heat transfer coefficients are only offered for velocity up to 4.0m/s. Values of clothing permeability offered are only valid for air velocity under 0.2m/s.

3 Experiment

A mist cooling system with a fan was set up outdoors in an area partially shaded by buildings and trees at our university during an open campus event for high school

students and their families. The mist was directed to an area well shaded by trees usually used as a resting area with benches and chairs available.

The main experiment measured both the change in skin temperature and the perception of thermal comfort of the subjects before and after entering the mist area. However, as the subject were volunteers recruited “on the street”, a rigid experiment protocol with multiple trials per subject was not practical. Secondary experiments measuring skin temperature of a small number of subject in a more regular manner were also done, however, with repeated trials on a small number of people, a thermal comfort survey was not done.

3.1 Experiment apparatus for main trials on thermal comfort perception

The mist cooling system consists of a hydraulic pump, hoses, a ring header and 8 nozzles. The nozzles are mounted around the edge of an oscillating fan with a diameter of 35cm and a flow straightener cowling. The pump pressurizes the water to 6MPa, producing a mist from the nozzles with droplets of Sauter Mean Diameter of 25 microns. The flow rate of each nozzle averages to 0.67ml/s, yielding a total mist flow of 5.35ml/s, or about 19L/h at the nozzle outlets. During the trials, the mist was seen to completely evaporate within about 5m of the fan.

The airspeed immediately in front of the fan was 7m/s as measured with a hot-wire anemometer with the nozzle spray off. The fan has an oscillation period of 30 seconds, swinging over a 90 degree arc, but it was kept in a fixed position for most experiments excepting brief periods during the trial in which participants asked to see the oscillation in action. Most participants stood directly in the line of the fan, with a maximum of 3 participants at one time, such that all could experience the mist cooling. Some participants chose to sit on a bench located 4m from the fan. The velocity profile along the centerline of the fan at set distances is given in Table 1.

Additional misting was produced from 8 more nozzles of the same type and flow rate from stationary headers. One placed near a bench at a height of 50cm spraying diagonally upward, and one mounted to the building wall at 3m height spraying diagonally downward to help cool the area as well as some of the air entrained into the fan. Most participants would choose to stand near in front of the fan. It should be noted that the air velocity near the fan exceeds the limits on locally controlled air velocity in the ASHRAE Thermal Comfort Tool based on ASHRAE 55-2010 as supported on the UC Berkeley Center for the Built Environment web tool. (Tyler et al. 2013)

Air temperature and humidity were measured with data recorders equipped with temperature/humidity sensors. Skin temperature of the test subjects was measured on the face and forearm with two non-contact infrared thermometers designed for medical use, accurate to 0.2°C. A box was designed to assure repeatability in measuring the same location of the arm with a hole to insert the arm, a hand grip to keep the arm in place, and a second smaller hole through which to read the skin temperature. A similar rig was attempted for the head with a cradle for the chin and a mounted non-contact thermometer, but proved impractical during testing and was not used. Two thermo-cameras were used to take images of each subject. Six stopwatches were used to record the time each person spent in the mist. Globe thermometers were used to measure the mean radiant temperature of the test space.

The testing area was in a shaded area near the entryway for the buildings of the department. Students and families visiting the department would first encounter the

mist testing setup. Most families had walked approximately 5 minutes from the nearby train station along a brick walkway, partially shaded by trees. Some arrived after visiting other departments on campus. A small number tried the mist when leaving the building. It is assumed the metabolic rate of all subjects is that for slow walking.

Table 1: Velocity profile of the mist fan with mist off

Distance from fan (m)	Air velocity (m/s)
0.0	7.0 - 7.2
1.0	6.3 - 6.7
2.0	5.3 - 5.7
3.0	3.2 - 3.5
4.0	2.6 - 2.8
5.0	1.8 - 2.0
6.0	1.5 - 1.8



Figure 1: Left: Photo of the test area. Right: Staff and test subjects during testing.

To estimate the amount of mist impacting per unit area, some trials with mist collectors set at 3m and 4m from the fan along the centerline were done in a 8m X 5m X 3.5m room, such that the room quickly became saturated, retarding evaporation of the mist and evaporation of collected mist from the collector itself. This should yield a maximum possible mist impact per unit area. With this fan, the value was $1.75 \times 10^{-4} \text{g/cm}^2 \text{s}$ at 3m and $4.6 \times 10^{-4} \text{g/cm}^2 \text{s}$ at 4m. In actual use the amount is much lower due to evaporation. Given a heat of evaporation of 2450kJ/kg for water. The potential cooling from evaporation of the $0.014 \text{g/cm}^2 \text{s}$ is over 1000W/m^2 .

3.2 Procedure for main trials on thermal comfort perception

Experiment subjects were recruited from the visitors to the university on the weekend of the Osaka City University open campus event, August 10 -11, 2013. Approximately 10% of those visiting the department took part in the experiment. There may be some selection bias as people who may expect the mist to be unpleasant would choose not to participate.

The weather on each day was sunny and among the hottest days of the year, the nearest meteorological station at Sakai (about 5km from the test site) recorded a high temperature of 36.9°C on August 10 and 37.6°C on August 11, making it the second hottest day of that year. Due to safety and accuracy concerns with the globe

thermometer stands, the globe thermometer measurements were done on the following weekend, under similar weather conditions, sunny and hot (36.3°C at Sakai). Globe temperature in the shaded area when not using mist was found to match the air temperature.

As each person approached the area a staff asked if the person would like to take part in an experiment with mist for “about 5 minutes”. If the person accepted, the following steps were taken.

1. Staff asks the personal data questions (age, sex, etc.) on the survey form or asks the subject to fill those items in.
2. Staff quickly checks off boxes on the “clothing worn” chart. The system may be confusing and not left to the subjects.
3. Staff measures temperature of the right cheek under the eye with the IR thermometer and notes it on the form.
4. Staff asks subject to put the right arm in box and grip the handle, then measures the forearm temperature with an IR thermometer.
5. Staff takes images of the face and forearm with the thermo-camera.
6. Staff quickly explains the thermal sensation, comfort and wettedness ranks and asks the person to make their votes before entering the mist.
7. Staff also explains the special item on perception of wettedness.
8. Staff starts a stopwatch, gives it to the subject and notes the time on the form.
9. Staff tells subject to enjoy the mist for as long as desired, to stand or sit if desired, and to return to the survey table when done.
10. When done, the stopwatch is collected and total time spent in the mist noted.
11. Arm and face IR temperature and thermo-camera images are done again.
12. The subject is asked to vote on thermal sensation, comfort and wettedness feelings he/she felt while in the mist.
13. Subject is asked to write any additional comments as desired and thanked for his/her time.

The procedure was not followed in exact order when the number of subjects exceeded the number of staff taking measurements. At times, there were delays of up to 1 minute between exiting the mist and temperature measurements.

A total of 141 subjects completed the survey forms. There were some omissions in a handful of cases. However there was a large number of omissions on the “perception of wettedness” item, which was only completed correctly by 59 people. Though 17 more only answered the after mist item, omitting the before mist item.

3.3 Survey questions

The survey form included the following items.

Personal data: age, sex, home prefecture (state), wearing sunblock? wearing makeup?

Clothing worn: A simple diagram of a body with check boxes for shirt, half sleeve, long sleeve, shorts, knee length shorts, pants, socks, hat, gloves, sandals, skirt,

stockings/leggings. Due to the hot weather, each check box is later correlated with the lightest weight article from the clothing insulation chart in the ASHRAE Handbook (ASHRAE, 2005). All subjects were assumed to be wearing the lightest weight clothing possible on the hottest week of the year, which proved true.

Skin temperature: Arm and face (cheek). Before mist and after mist.

Thermal sensation: 9 level scale starting at Extremely cold (-4), very cold, cold, cool, mild, warm, hot very hot, extremely hot (+4)

Overall comfort: 7 level scale starting at Very uncomfortable (-3), uncomfortable, slightly uncomfortable, neither, slightly comfortable, comfortable, very comfortable (+3)

Skin wettedness sensation: 7 level scale starting at Very dry (-3), dry, slightly dry, neither, slightly wet, wet, very wet

Wettedness impression: The subject was asked, if feeling wettedness, “Is the wet feeling pleasant, unpleasant, or neither?” If the subject did not understand the concept, it was explained “For example, if you are damp from sweating, does that feel unpleasant?” Some staff forgot to ask subjects about this item.

Comments: Free comment section.

3.4 Results of main trials on thermal comfort perception

Survey form data was entered into a spreadsheet. The averages of all 141 cases are shown in the tables below. The skin temperature change averaged a drop of 1.1 °C at the arm, and 1.0 °C at the face. The thermal sensation started at an average of +2.7 (hot) before misting and dropped to -1.41 (slightly cool) after misting. Wettedness sensation increased, but as shown in the pie charts below, 75% of wettedness after misting was rated as pleasant, where wettedness had been rated as 75% unpleasant before misting.

Table 2: Measured skin temperatures before and after misting

	Measured point	Average (°C)	Std. Dev. (°C)
Before mist	Arm	34.0	0.92
	Face	34.9	0.87
After mist	Arm	32.9	1.49
	Face	33.9	1.20
Temperature change	Arm	-1.1	1.24
	Face	-1.0	1.06

Table 3: Results of thermal comfort votes from before and after misting

		Average	Std. Dev.
Before mist	thermal sensation	+ 2.71	0.93
	comfort sensation	- 1.41	1.04
	wettedness sensation	+ 0.82	1.21
After mist	thermal sensation	- 0.35	0.95
	comfort sensation	+ 1.82	1.01
	wettedness sensation	+ 1.56	0.86
Comfort level change	thermal sensation	- 3.06	1.33
	comfort sensation	+ 3.23	1.27

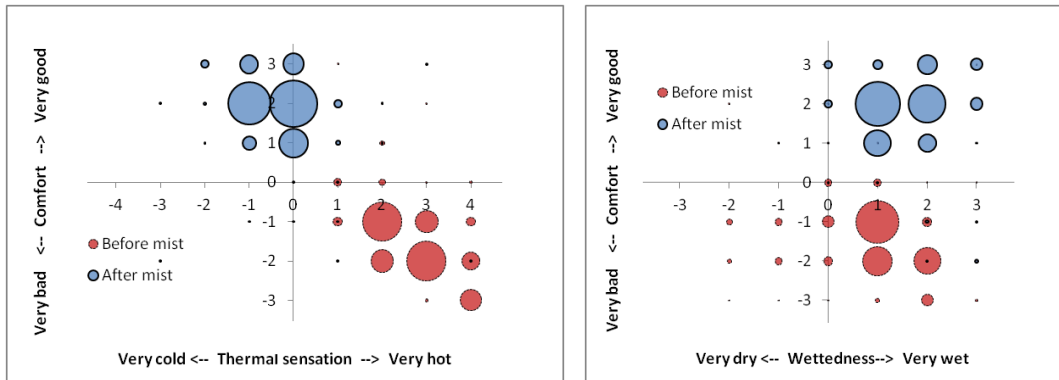

Figure 2: Left: Plot of thermal sensation votes vs. comfort votes with bubble size proportional to number of people. Total 141 people. Right: Plot of wettedness votes vs. comfort votes.

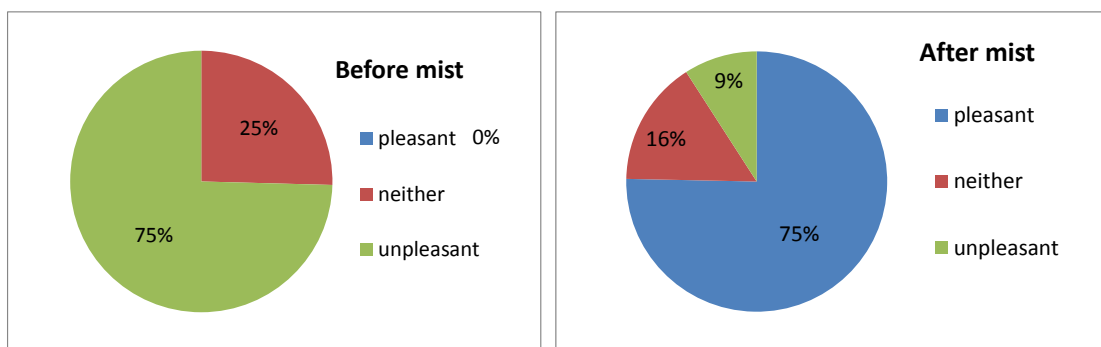

Figure 3: Perception of skin wettedness before and after entering mist.

The change in temperature of each case, and the change in the vote are plotted against the total time spent in the mist in the figures below. There is no clear trend in any case.

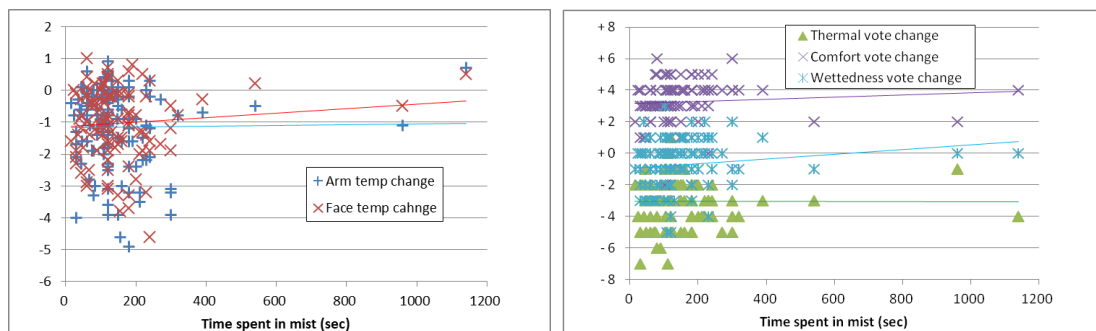

Figure 4: Difference in results before and after mist plotted against time spent in mist. Left: temperature changes. Right: thermal vote changes

No correlations could be developed from clo values, as the clo value of most subjects was nearly the same. The average was 0.37clo, with a standard deviation of only 0.08clo. Most people were wearing their lightest clothing for the hot summer day. For example, only 11% of subjects wore long sleeves of any kind. Only 40% wore pants or skirts of ankle-length. The results showed that skin temperatures dropped by about 1 degree, and comfort nearly universally improved.

3.5 Procedure for transient measurement of skin temperature

During preparatory experiments and during the trial itself, it became clear that skin temperatures changed noticeably and rapidly, if not instantly, when exposed to the misting fan. A more controlled set of experiments was done with the 4 staff to measure the change in skin temperature over time. Each staff subject stood at a set distance from the fan between 3 – 6m with one arm relaxed but extended outward at the elbow, parallel to the ground, exposing the inner side of the forearm to the mist. The inner side was chosen due to there being less body hair to interfere with the result. (In the author’s personal experience, body hair can act as a mist droplet trap.)

An IR thermometer was held in the other hand, moved to a single spot on the arm, the measurement trigger pulled, then the thermometer is removed to the side to avoid blocking mist. In the first set of trials, this was repeated every 30 seconds, remaining in the mist for 120 seconds. In the later trials this is repeated every 5 seconds without leaving the mist. The measurements were first done about 4 times to establish a baseline, then the subject walked into the misted area and performed the measurement. The test was also repeated with only the fan running and no mist. The details of the trials are shown in the table below. Air temperature ranged from 30.3 – 30.4C, with relative humidity at 50% and a wet bulb depression of 7.8K

Table 4: Transient skin temperature measurement conditions for long measurement period trials

Case	Meas.period (s)	Dist. From fan (m)	Mist?	Init skin temp (°C)
A	30	6	Yes	31.5
B	30	4	Yes	33.4
C	30	4	Yes	33.9
D	30	4	No	33.9
E	30	4	No	31.4
F	30	4	Yes	31.3
G	30	6	Yes	33.4
1	5	6	Yes	32.1
2	5	4	Yes	31.7
3	5	5	Yes	31.8
4	5	4	Yes	33.9
5	5	4	Yes	31.9
6	5	3	No	31.1
7	5	3.5	Yes	34.2
8	5	3	Yes	32.4
9	5	3	Yes	31.8
10	5	4	Yes	34.7
11	5	4	No	31.8
12	5	4	No	34.1

3.6 Results for transient measurement of skin temperature

Plotting the change in temperature over time, with the base temperature as the average of the 4 measurements before entering the mist shows drops in most misting cases, but no significant change in the fan only cases with no mist. Stronger drops tend to happen at closer distance. Longer trials at 30 second intervals showed the time to recovery after leaving the

mist (at 120s) could be 2 minutes or up to 7 minutes. The arm had become significantly wet in these cases.

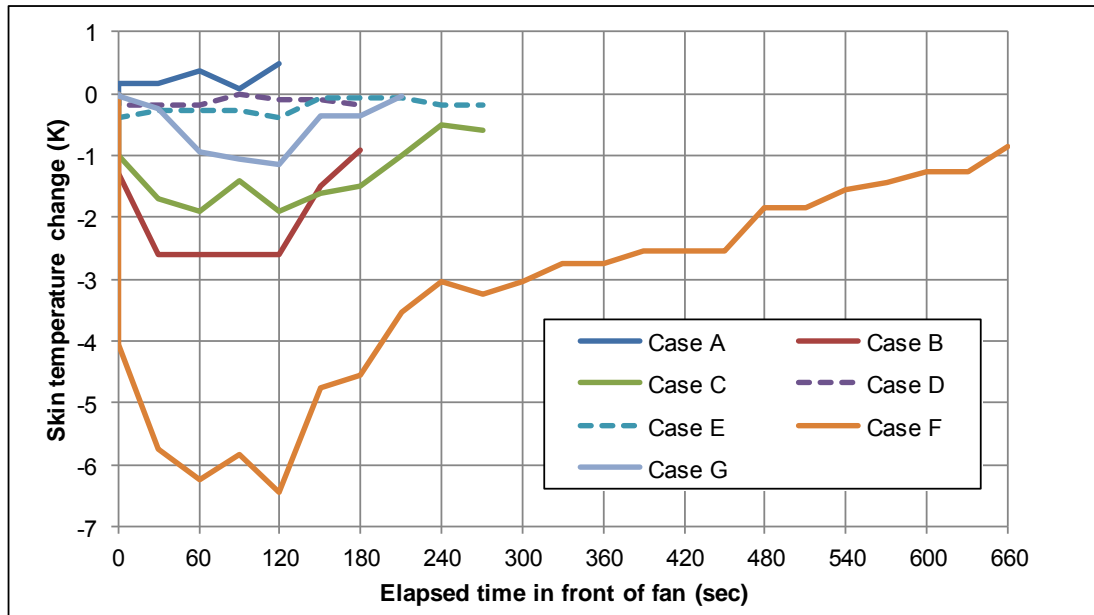

Figure 5: Change in skin temperature and after entering mist, remaining for 120 seconds, then leaving.

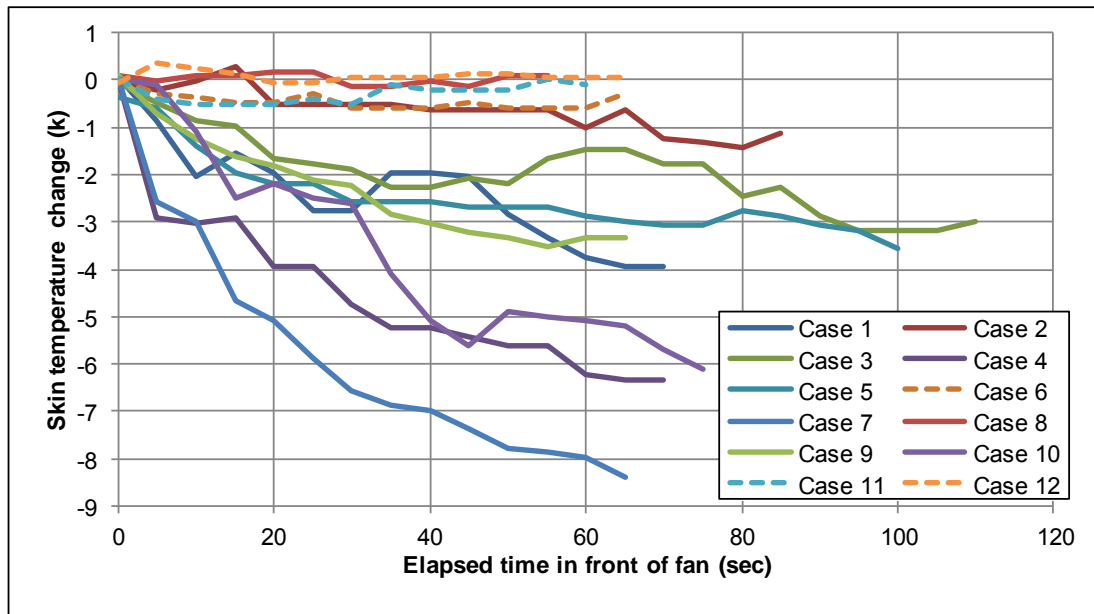

Figure 6: Change in skin temperature measured every 5 seconds and after entering mist.

Skin temperatures drop quite rapidly even in sparse mists, often 2 degrees in the time it takes to get the first measurement. The fan alone in these cases yields little or no drop in skin temperature. Mist seems to provide instant relief from the heat. With continuing drops over time and lingering effects after the skin becomes wet.

4 Conclusions and Discussion

Mist nozzles combined with a fan can yield great relief to thermal discomfort on hot summer days even in a relatively humid climate such as in Japan. Skin temperatures were measured as 1 degree cooler even after leaving the mist. Measurements taken inside the mist showed that exposed skin temperatures could drop 2 degrees within 5 seconds with light wetting. The density of the mist in the misting fan used here could easily exceed the maximum potential cooling due to sweat evaporation alone.

This effect is likely the result of skin wetting and subsequent evaporation. Although wet skin is typically assumed to be unpleasant, in this case the test subjects were asked if the wet sensation felt pleasant or unpleasant. 75% of respondents said the wettedness from the mist was pleasant, while 75% of respondents had claimed their state of wettedness before entering the mist (due to their own sweating) was unpleasant.

No correlation could be found between time spent in mist and degree of effect. This was likely due to allowing the subjects to freely choose their location in the misted area. The visible nature of misting may help people better control their own experience. Mist evaporates away at greater distance from the fan, so subjects seeking more cooling may choose to stand in the visibly dense mist, while those worried about wetting may choose to stand beyond the visible mist cloud.

Research will continue towards quantifying the effects and developing a model of mist cooling comfort.

References

ASHRAE, 2005. *ASHRAE Handbook – Fundamentals. Ch. 8 Thermal Comfort*. Atlanta.

Biddinger P., Adler J., Plantz S., Stearns D., Gossman W., 2002. *Emergency Medicine – 2nd edition*. Lippincott Williams & Wilkins, Baltimore. p. 39.

Brisson G., Boisvert P., Peronnet F., Quirion A., Senecal L., 1989. Face cooling-induced reduction of plasma prolactin response to exercise as part of an integrated response to thermal stress. *European Journal of Applied Physiology*. 58. pp. 816-820.

Chaker M, Meher-Homji C, and Mee III, T. 2002. Inlet Fogging of Gas Turbine Engines – Part A, *Proc. Of ASME Turbo Expo*, Amsterdam, Report #2002-GT-30562.

Farnham C., Nakao M., Nishioka M. Nabeshima M., Mizuno T., 2009. A Proposal for a Mist Cooling Control and Measurement Methods, *Trans. of the JSRAE*, Vol.26, No.1, pp. 105-112. (In Japanese)

Hayashi M, Sugahara T, Nakajima H (1998) Temperature and Humidity Environments inside a Naturally Ventilated Greenhouse with the Evaporative Fog Cooling System. *Environment Control in Biology*, Vol. 36, No. 2, pp.97-104. [in Japanese]

Holterman H. 2003. *Kinetics and evaporation of water drops in air*. IMAG, (Report 2003-12/Wageningen UR) Wageningen, The Netherlands.

JABMEE-Japan Building Mechanical and Electrical Engineers Assoc. 1992. *HASP/ACSS/8502 Program Manual*, Tokyo. (in Japanese).

Miura T, Itatani T, Kuriki S, Takuma M, Kinoshita Y, Kosugi S, Zinno K. (2008) Experimental Study on Evaporation Cooling Effect by Sprayed Mist. Architectural Inst. of Japan Congress. Chugoku. p. 559. [in Japanese]

Suzuki T, Miura T, Itatani T, Kuriki S, Takuma M, Kosugi S. (2009) Experimental Study on Evaporation Cooling Effect by Sprayed Mist in Indoor Space: Part 2 Evaporation Cooling Effect by Using Sprayed Mist with Circulation Fan. *Architectural institute of Japan Congress*. Tohoku. pp.563-564.

Pruppacher, H., Klett J., 1997. *Microphysics of clouds and precipitation*. Dordrecht: Kluwer Academic Publishers. pp. 509-510

Uchiyama S., Suzuki K., Tsujimoto S., Koizumi H., 2008. Evaluation of Reducing Temperature in a Train Station with Mist. *Japan Society of Plumbing Engineers*, Vol. 25, No. 2. pp. 8-11. (in Japanese).

Hoyt T., Schiavon S., Piccioli A., Moon D., and Steinfeld K., 2013. CBE Thermal Comfort Tool. Center for the Built Environment, University of California Berkeley, <http://cbe.berkeley.edu/comforttool/>

Yamada H., Okumiya M., Tsujimoto M., Harada M., 2006. Study on Cooling Effect with Water Mist Sprayer : Measurement on Global Loop at the 2005 World Exposition, *Arch. Inst of Japan Conference Summaries*, Kansai. pp. 677-678. (in Japanese)

Does PMV unnecessarily restrict natural ventilation in buildings?

Kevin Bowe¹

1 Heriot Watt University, UK;

Abstract

In this paper, a global map of maximum indoor operational temperatures of buildings is presented. Maximum indoor operational temperatures were evaluated around the world using both PMV and ATC. It is found that utilising ATC to establish a building's design comfort temperatures gives a higher acceptable indoor operative temperature compared to PMV and thus widens the potential temperatures for the use of natural ventilation in buildings while not compromising their ability to provide comfort for adapted populations, suggesting that PMV does unnecessarily restrict the use of natural ventilation for comfort cooling.

It is found that using CIBSE TM52, 100% of Europe can utilise the ATC. If ASHRAE 55-2013 standard is used, 97.1% of global locations can use ATC. It was also found that 89% of global weather files have a temperature difference between ATC and PMV of between 5K and 9K.

Keywords: PMV, Adaptive Thermal Comfort, Natural Ventilation, Comfort comparison, Weather Files

1. Introduction

The measurement of building occupants thermal comfort has, for the last half century, been primarily assessed using two different models: one based on laboratory experiments and steady-state calculations and the other known as the 'Adaptive Method' based on field studies. The Adaptive Thermal Comfort (ATC) model, which is included in such standards as the American ASHRAE 55-2013 standard, the European EN15251 standard and most recently the UK CIBSE TM52, allows warmer indoor operative temperatures of naturally ventilated buildings during summer to be deemed as acceptable and is based on the daily running mean of the local climates. The steady state model, Percentage Mean Vote (PMV), has been the dominant method used by building service engineers over recent decades to predict comfort temperatures in buildings but does not explicitly take into account weather variables.

Thermal comfort standards significantly influence the energy consumed by a building's environmental systems and in turn its carbon emissions and environmental impacts (Yao et al., 2009). Selecting an appropriate thermal comfort model for a building is thus key to lowering this energy consumption. PMV has been typically used as the standard model to assess comfort levels. PMV is a steady stated model and does not explicitly take into account the climate in which the building is located.

ATC on the other hand, takes into account the external conditions when assessing comfort.

When modelling a building, a designer will select “input” parameters to achieve a desired “output”, a building design. These model inputs are traditionally insulation levels, air permeability, lighting levels, percentage glazing, glazing type etc. The two key model outputs considered are energy consumption and thermal comfort which are inextricably linked, as are, in turn the input parameters to thermal comfort. All of these input parameters can be changed, apart from one, the local weather. For a building designer, the weather in a particular location is key to understanding the strategies to deliver a sustainable building.

Building designers around the world have a number of weather file databases to access. A freely available source is provided by the U.S. Department of Energy (2013). This paper uses these weather files (2598 locations around the world) to demonstrate the potential savings of adapting a building to its local environment.

2. Methods

PMV and ATC can both determine the indoor operative temperature of a room. Using ATC, a maximum acceptable indoor operative temperature can be calculated using the exponentially weighted running external daily mean temperature. On the other hand, the PMV method focusses on the following parameters:

- Metabolic rate (M [met])
- Thermal resistance of clothing (I_{clo} [clo])
- Air temperature (T [°C])
- Mean radiant temperature (T_{mrt} [°C])
- Relative air velocity (v [m/s])
- Relative humidity (RH [%])

To reduce the analytical search space required, the following assumptions are made:

- Metabolic rate is of an office worker ($Met = 1.1$; Office Typing as outlined in Standard ASHRAE 55 (2013))
- Thermal resistance of clothing is of an office worker ($Clo = 0.6$)
- the air temperature and mean radiant temperature are equal
- the relative air velocity is assumed low ($Vel = 0.1$ m/s)
- the indoor relative humidity is calculated using the minimum external humidity ratio

In ANSI/ASHRAE Standard 55 (Standard ASHRAE 55, 2013), comfort is classified by predicted percentage dissatisfied. The <10 bands equates to a PMV of ± 0.5 . BS EN ISO 7730 (BSI, 2005) buildings are classified as A, B or C on the basis of the range of acceptable internal temperatures as calculated using PMV encountered. For this paper, classification B was selected which allows a PMV range of ± 0.5 . In European standard BS EN 15251 (Olesen, 2007) the acceptable ranges of PMV are categorised

I, II and III. An ASHRAE ‘90%’ class, BS EN 7730 ‘B’ class and a BS EN15251 ‘II’ class are all equivalent by means of their acceptable PMV range.

In the first step, the exponentially weighted running mean was calculated for all location using the external dry bulb temperature and an alpha value of 0.8 as recommended in TM52 (CIBSE, 2013). Utilising the formula laid out in TM52 (CIBSE, 2013), a category ‘2’ building was selected as equal to that of the PMV class building and thus the maximum indoor operative temperature was calculated by:

$$\text{Equation 1 - ATCtemp}$$

where T_{m} is the exponentially weighted running daily mean external temperature.

In the second step, to remove the building variable from the study, the same, above, uniform building assumptions were applied at each location. Utilising a PMV index of +0.5, the highest possible operative temperature would occur when the internal relative humidity would be at its minimum. As the internal relative humidity could not be known as no actual building is presented in this study, it is assumed that the minimum internal relative humidity possible is that of the minimum external humidity ratio at the internal temperature. Though this may never be the case, due to latent heat from internal gains such as people, it would result in the theoretical maximum operative temperature for any space. Using these assumptions the calculation was run to find the indoor operative temperature which satisfied a PMV index of +0.5.

The temperature difference between the two operative temperatures was then calculated for all locations around the world.

3. Results

Due to the large number of locations, results for only a sample of the locations are shown in Table 1.

Table 1. Sample of Results

Country	State	City	PMV	ATC Temp	PMV Temp	Delta T
				(Deg C)	(Deg C)	(K)
KWT	-	Kuwait Intl Airport	0.5	38.9	27.71	11.19
IND	-	NAGPUR	0.5	38.3	27.41	10.89
USA	CA	Needles Airport	0.5	38.38	27.77	10.61
PLW	-	Koror Island	0.5	35.07	25.76	9.31
CHN	Sichuan	Yibin	0.5	35.6	27.41	8.19
CUB	-	Punta de Maisi	0.5	35.45	27.26	8.19
MDV	-	GAN_ISLAND	0.5	35.45	27.31	8.14
ESP	-	VALENCIA	0.5	34.58	27.72	6.86
USA	MI	Howell	0.5	34.58	27.72	6.86
USA	MD	BALTIMORE	0.5	34.57	27.71	6.86
RUS	-	MOSCOW	0.5	33.15	27.7	5.45

FRA	-	NANTES	0.5	33.12	27.67	5.45
AUS	WA	Albany Airport	0.5	32.8	27.35	5.45
CHN	Qinghai	Tuotuohe	0.5	28.88	27.85	1.03
CHN	-	PAGRI	0.5	28.75	27.85	0.9
USA	AK	BARROW	0.5	27.71	27.51	0.2
CAN	NU	Resolute	0.5	27.37	27.52	-0.15

It can be seen in Table 1 that a difference in operative temperatures ranges from negative 0.15 K in Resolute, Canada (the only negative temperature difference) to positive 11.19 K in Kuwait International Airport, State of Kuwait.

Once all results were tabulated, they were incorporated into google maps for ease of viewing. It can be seen in Figure 1 that there are a number of weather files for Europe, North America, China and Australia, but the rest of the world is sparsely populated.

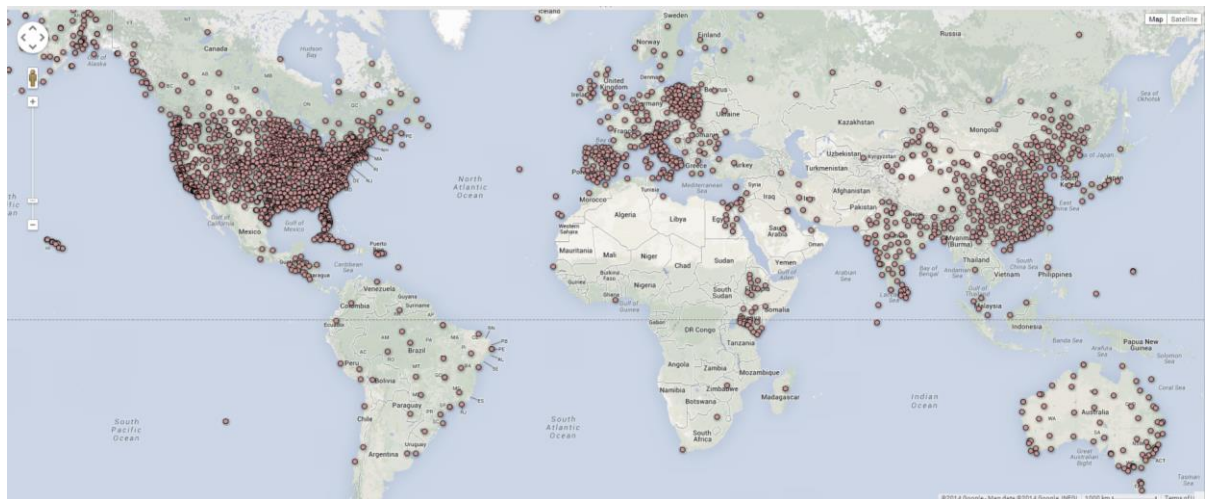

Figure 1. Interactive Map of the World

As seen in Figure 2, by clicking on any marker, the maximum ATC temperature, maximum PMV temperature and the temperature difference (Delta T) are displayed. Information such as the weather file used is also displayed. Additional information (longitude, latitude, ASHRAE climate zone, Koppen Climate Zone, Atmospheric pressure, Humidity Ratio, TM52 Compliance, ASHRAE 55 Compliance, Exponentially Running Mean Outdoor Temperature) can be added to the displayed window easily.

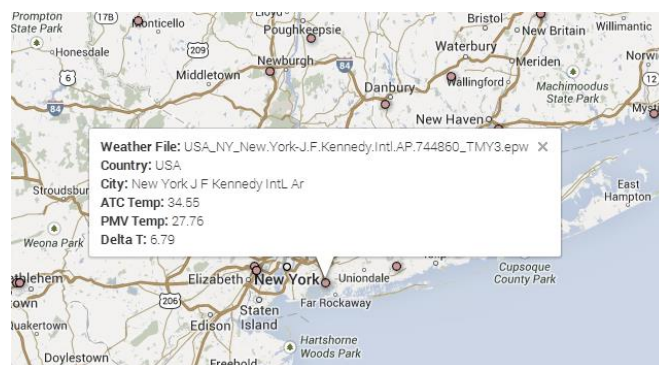

Figure 2. Interactive Map, Viewing Information

Figure 3 shows a frequency distribution of the temperature difference between the ATC and PMV maximum operative temperature. It can be seen that 70% of all global locations fall into the bins between 6 K and 8 K, 81% between bins of 6 K and 9K, and 89% between 5 K and 9 K.

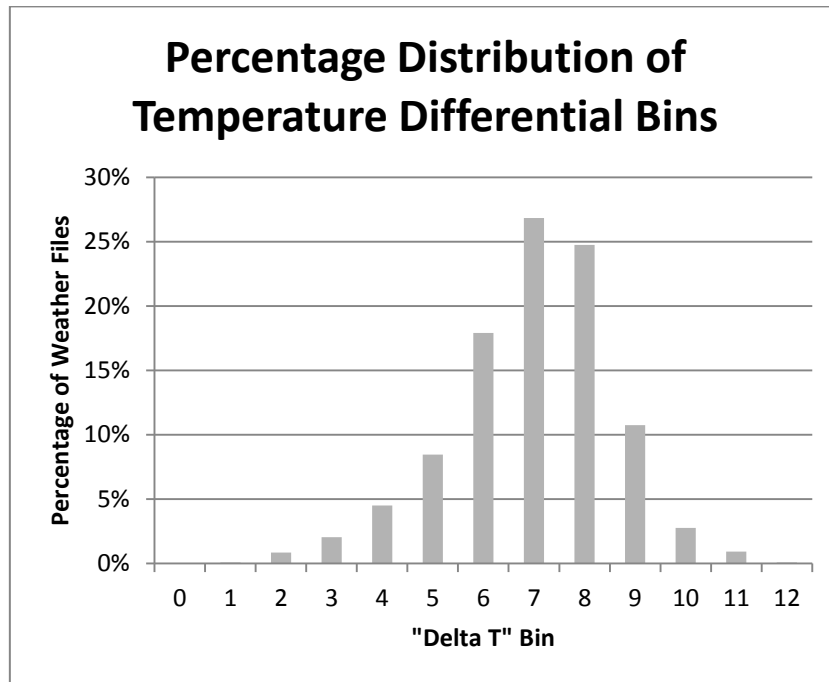

Figure 3. Percentage Distribution of Temperature Differential Bins

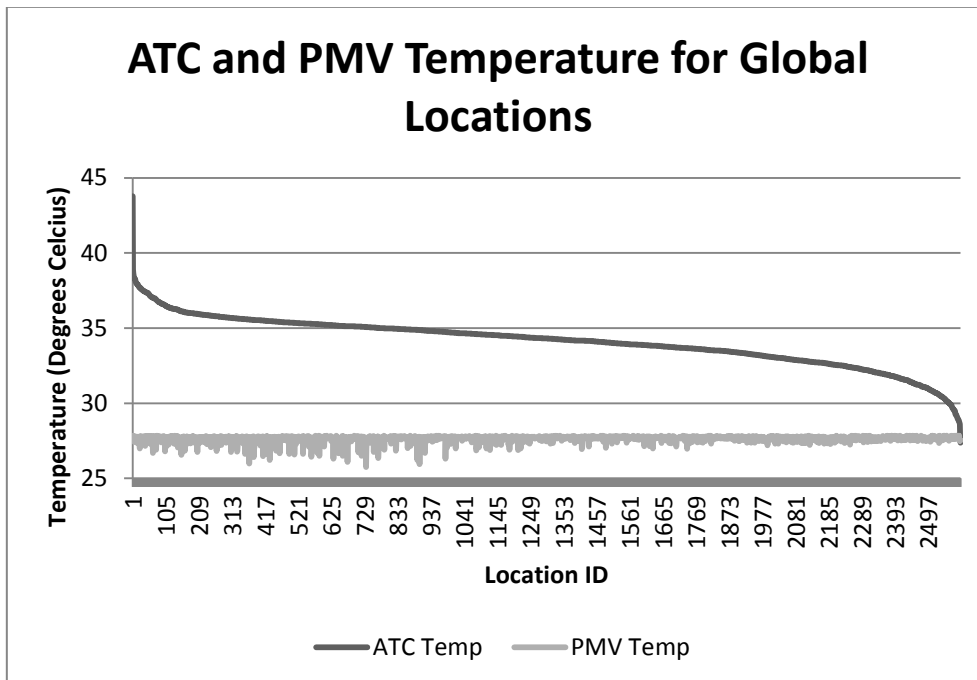

Figure 4. ATC and PMV Temperature for Global Locations

In Figure 4, it can be seen that some location reach an ATC_{temp} of near $44^{\circ}C$.

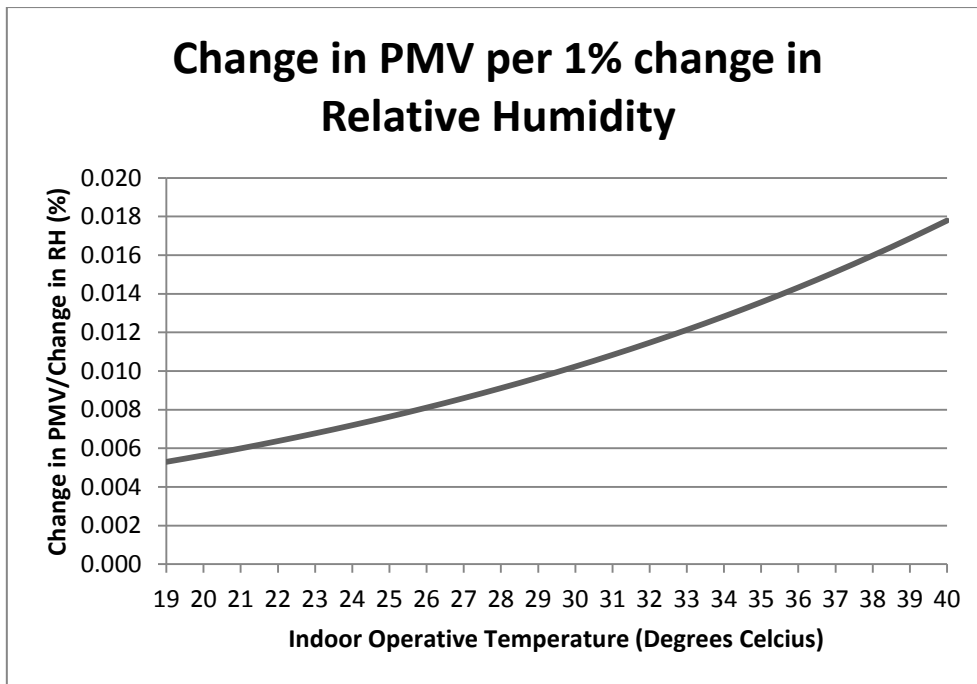

Figure 5. Change in PMV per 1% change in Relative Humidity at varying Indoor Operative Temperature

Figure 5 shows the change in PMV for a one percent change in relative humidity at different indoor operative temperatures. This calculation used the following assumptions:

- Metabolic rate is of an office worker (Met = 1.1)
- Thermal resistance of clothing is of an office worker (Clo =0.6)
- the air temperature and mean radiant temperature are equal
- the relative air velocity is assumed low (Vel = 0.1 m/s)

However this graph is valid for any static value of metabolic rate and thermal resistance of clothing. This shows that the higher the operative temperature, the higher the variation in PMV index per unit change in relative humidity.

To compare MET values between different standards, the calculations were rerun using a MET value of 1.2. This decreased the PMV maximum indoor operative temperature by between 0.5K and 0.6K, with the average change being 0.56K.

Table 2 shows the global weather files which fail the ASHRAE 55 criteria of the maximum allowable T_{rm} (33.5°C). Some of these weather files are for duplicate locations. For example, Las Vegas has three weather files that fail this criteria.

Table 2. Locations that Fail ASHRAE 55 Maximum Trm

Country	State	City	Max T_{rm}
KWT	-	Kuwait Intl Airport	39.69
KWT	-	KISR Coastal Weather Station	38.90
IND	Rajasthan	Kota	38.46
USA	CA	Needles Airport	38.13
IND	-	NAGPUR	37.89

USA	CA	Blythe Riverside Co Arpt	37.87
SAU	-	RIYADH	37.72
USA	NV	Nellis Afb	37.69
IND	Rajasthan	Bikaner	37.20
USA	AZ	Luke Afb	37.12
USA	AZ	Yuma Mcas	36.94
IND	Madhya Pradesh	Gwalior	36.92
USA	AZ	Scottsdale Muni	36.89
EGY	Aswan	Aswan	36.67
IND	Chhattisgarh	Raipur	36.64
USA	AZ	Phoenix Sky Harbor Intl Ap	36.62
IND	Rajasthan	Barmer	36.61
ARE	-	ABU DHABI	36.36
USA	AZ	Yuma Intl Arpt	36.18
USA	AZ	Phoenix/Int'l Airport	36.17
IND	Maharashtra	Nagpur	36.15
USA	CA	Palm Springs Intl	36.04
IND	Andhra Pradesh	Ramagundam	36.04
IND	Haryana	Hissar	36.01
USA	AZ	Deer Valley Phoenix	35.86
USA	AZ	Casa Granda Awos	35.82
IND	Delhi	New Delhi	35.78
IND	Maharashtra	Akola	35.65
IND	Punjab	Amritsar	35.65
IND	Rajasthan	Jaisalmer	35.59
USA	AZ	PHOENIX	35.49
IND	Rajasthan	Jodhpur	35.47
EGY	-	ASWAN	35.41
IND	Rajasthan	Jaipur	35.40
AUS	WA	Newman Airport	35.37
CHN	-	TURPAN	35.29
IRN	-	Bandar Abass	35.29
IND	Uttar Pradesh	Allahabad	35.23
IND	Uttar Pradesh	Gorakhpur	35.17
IND	Gujarat	Ahmedabad	35.16
USA	AZ	Yuma	35.10
IND	-	AHMEDABAD	35.06
USA	UT	Saint George Awos	35.05
EGY	Al Wadi al Jadid	Kharga	35.04
IND	Madhya Pradesh	Bhopal	35.04
USA	CA	Imperial	35.00
AUS	WA	Meekatharra Airport	34.95
IND	-	NEW DELHI	34.94
USA	CA	Daggett Barstow Daggett Ap	34.92

USA	NV	Las Vegas Mccarran Intl Ap	34.81
USA	CA	Palm Springs Thermal Ap	34.64
USA	CA	China Lake	34.61
IND	Andhra Pradesh	Kurnool	34.49
AUS	WA	Giles	34.47
USA	NV	LAS_VEGAS	34.34
IND	Uttar Pradesh	Lucknow	34.27
CHN	Xinjiang Uygur	Turpan	34.23
IND	Maharashtra	Sholapur	34.18
IND	Madhya Pradesh	Jabalpur	34.16
IND	Andhra Pradesh	Hyderabad	34.15
USA	NV	Las Vegas/Int'l Airpor	34.12
EGY	Qina	Luxor	33.99
USA	CA	Twentynine Palms	33.97
IND	Andhra Pradesh	Nellore	33.96
IND	Bihar	Bhagalpur	33.94
ISR	-	Eilat	33.91
IND	Bihar	Patna	33.90
AUS	SA	Oodnadatta Airport	33.89
USA	CA	Barstow/Daggett	33.87
USA	CA	DAGGETT	33.86
AUS	WA	Wyndham	33.72
USA	TX	Del Rio Laughlin Afb	33.71
IND	-	CHENNAI	33.62
USA	OK	Altus Afb	33.62
CHN	Hubei	Wuhan	33.52

4. Discussion

As seen in Figure 4, the PMV maximum operative temperature varies minimally around the world. This small change is due to the fact that PMV is totally based on indoor criteria and the only input parameter that is varied for each location is relative humidity. It could be seen that clothing levels and metabolic rate would also change dependent to the local environment (weather, culture, gender, activity and authorities figures to name but a few). It can also be seen that by adopting ASHRAE Standard 55 ATC for buildings around the world, 97.1% of locations could potentially adopt more no-energy consumption strategies, by reverting to the use of naturally ventilated buildings.

5. Conclusion

For all but one location around the world, ATC calculation allows for higher internal operative temperatures. This means a designer has a greater possibility to incorporate natural ventilation once the daily climate allows for heat purging from the building at night. 76 locations had a maximum exponentially running mean that was higher than 33.5°C and thus are prohibited from using the ASHRAE Standard 55 ATC criteria.

6. Further Studies

More work is needed to determine the impact of design comfort criteria in relation to future weather predictions and the resulting energy needs to keep buildings adequately warm or cool in a changing climate. In which regions of the world can we adapt to future climate with free-running buildings? The growing challenge of providing comfort in more extreme climates also begs the question of can we better utilise thermal mass storage to reduce or increase the indoor operative temperatures of spaces during prolonged high or low air temperatures using ambient energy, be it wind or sun.

References

BSI 2005. EN ISO 7730: 2005. *International standard: Ergonomics of the Thermal Environment-Analytical Determination of Thermal Comfort by Using Calculations of the PMV and PPD Indices and Local Thermal Comfort Criteria, International Standard Organization for Standardization, Geneva, Switzerland.*

CIBSE 2013. TM 52: The limits of thermal comfort, avoiding overheating in European buildings.

OLESEN, B. W. 2007. EN 15251: Indoor environmental input parameters for design and assessment of energy performance of buildings addressing indoor air quality, thermal environment, lighting and acoustics. *Technical University of Denmark, International Centre for Indoor Environment and Energy.*

STANDARD ASHRAE 55 2013. Thermal environmental conditions for human occupancy. U.S. DEPARTMENT OF ENERGY. 2013. *Weather File Database* [Online]. Available:

http://apps1.eere.energy.gov/buildings/energyplus/weatherdata_about.cfm?CFID=670304&CFTOKEN=3a1e1aebb54fb716-F3A30CA7-093D-4E19-3848B7CCA09640C1&jsessionid=6F02FFFD AF2F83074328BCBC94825351 .eere [Accessed 30/01/2013 2013].

YAO, R., LI, B. & LIU, J. 2009. A theoretical adaptive model of thermal comfort Adaptive Predicted Mean Vote (aPMV). *Building and Environment*, 44, 2089-2096

WINDSOR CONFERENCE 2014

COUNTING THE COST OF COMFORT

WORKSHOP 4

**Dynamic thermal environment: What is the mechanism?
How to create, control and evaluate it?**

Invited Chair: Yingxin Zhu

WINDSOR CONFERENCE 2014

COUNTING THE COST OF COMFORT

THE WORKSHOP PROGRAMME

WORKSHOP 4: Dynamic Thermal Environments: What are their underlying mechanisms? How can we create, control and evaluate them?

Invited Chair: Yingxin Zhu

11th April 2014: 16.30 – 18.30 – Sandby Room (2 Hours)

Although PMV has been widely used all over the world, it is developed based on the experiment in climate chamber with static and homogeneous thermal environment. In fact, the dynamic and inhomogeneous thermal environment is more universal. Many published investigations show that the human body has a wider acceptant temperature range in free-running buildings than that in air-conditioned buildings. Beside, people prefer more natural wind than mechanical wind in which occupants has better thermal comfort. Another finding is if the occupants have the ability to control the thermal environment, their thermal comfort will be improved and energy can be saving effectively. Some of these phenomena have been demonstrated in adaptive thermal comfort model, but what is the reason of these phenomena?

If dynamic thermal environment can help to improve indoor thermal environment and save energy, how should we create and control it, and how to evaluate the effect?

Proceedings of 8th Windsor Conference: *Counting the Cost of Comfort in a changing world* Cumberland Lodge, Windsor, UK, 10-13 April 2014. London: Network for Comfort and Energy Use in Buildings, <http://nceub.org.uk>

Applicability of elevated air movement for maintaining thermal comfort in warm environments

Li Huang¹, Yingxin Zhu¹, Edward Arens², Hui Zhang², Qin Ouyang¹

1 Tsinghua University, China, correspondence email huanglithu@gmail.com;

2 University of California, Berkeley, USA

Abstract

Providing cooling effect with low energy consumption makes the exploration of air flow utilization significant. In ASHRAE Standard 55-2010, the cooling effects of elevated air movement are evaluated using the SET index as computed by the Gagge 2-Node model of whole-body heat balance. Air movement in reality has many forms, which might create heat flows and thermal sensations that cannot be accurately predicted by a simple whole-body model, and the affected body surface might be variably nude (e.g. face) or clothed. The present study set up experiments in a climate chamber to identify the suitable range of indoor temperature to use desk fans and their corresponding range of air speeds. The proper method to evaluate the cooling effect of air movement is also addressed. The results show that SET index derived from the 2-Node model is effective at predicting thermal sensation even under different non-uniform air movement.

Keywords: SET, 2-Node, Comfort model, Air movement, Thermal sensation

1 Introduction

Studies on air movement cooling have brought substantial attention to the use of elevated air speeds to widen the acceptable range of thermal conditions (Toftum J, 2004; Fountain M and Arens E, 1993; Zhou X et al, 2006; Aynsley R, 2008). Suitable air flow can help to maintain people's thermal comfort in warm seasons during long-term stay in indoor environment. The cooling effect of air flow can raise the indoor set temperature to a certain degree, therefore effectively reduce a building's energy consumption.

Extensive field surveys showed that higher air flow rate was generally expected in neutral and warm environment in many existing buildings. According to the ASHRAE database (de Dear RJ, 1998), field investigations of thermal comfort across the world showed that over 70% of investigated air speed was lower than 0.2m/s, and the mean value of those higher than 0.2m/s was only 0.32m/s. With the sensation range of -0.7 to 1.5, far more people in the scale of 52% versus 3% required more, instead of less, air movement (Arens E et al, 2009). A study by the Berkeley Civic

Center also showed that when people felt neutral and warm, there was a general preference for higher flow rates (Zhang H et al, 2007). In two field experiments inside naturally ventilated buildings in northeastern Brazil, pooling the results for air speed up to 0.4 m/s, the percentage of occupants preferring “more air movement” represented over 70% of dissatisfaction with operative temperature varying from 25 to 31°C (Cândido C et al, 2011).

ASHRAE Standard 55-2010 uses the model PMV to determine comfortable temperatures under still air, and uses the SET (standard effective temperature) index as the basis for extending this still-air comfort zone under elevated air speeds. The SET index is derived from Gagge’s 2-Node model, which was introduced in 1970 (Gagge AP et al, 1972). The model considers a human as two concentric thermal compartments representing the skin and core of the body, producing a minute-by-minute simulation of the status of the human thermoregulatory system (Berglund LG and Stolwijk JAJ, 1978; Gagge AP et al, 1986). The model predicts skin temperature, skin wettedness, and thermal status for any combination of environmental and personal variables, including those outside the neutral range, and can be used to find the loci of environmental conditions that produce equal levels of heat loss. Therefore it appears reasonable to use SET as an index to evaluate cooling effect of elevated air movement.

However the environmental surroundings of a simplified model like 2-Node are assumed to be uniform. It is a ‘whole-body’ model, in which the entire body surface is represented by one average heat transfer coefficient, unlike a ‘multi-segmented model’, in which body segments are treated individually, and which are necessarily more complex. Recognizing the whole-body nature of SET, ASHRAE Standard 55 specifies that ‘average air speed’ be used as input to the model, which for sedentary occupants is defined as an average of airspeed measurements at 0.1, 0.6, and 1.1m above the floor.

There are many ways that air movement may be distributed across the body, uniform or non-uniform. The airflow from fans typically reaches only parts of the body surface. The airspeed across these exposed parts is higher than the average airspeed, and the physical and psychological effects may be sensitive to this difference.

In addition, whole-body models use an average clothing resistance value for the whole body surface (Arens E et al, 1986). But the airflow from fans passes over both clothed (e.g., trunk) or unclothed (e.g., face) portions of the body. While the heat loss from clothed and nude surfaces might be linearly related to clothing resistance, the psychological sensitivity may not be.

The present study set up experiments in a climate chamber to identify the suitable range of indoor temperature to use desk fans and their corresponding range of air speeds. It also examines each of the above issues as follows:

- 1) In a study in which fans provided non-uniform frontal air flow to the upper body, subjects’ actual thermal sensation votes (TSV) could be compared to SET values calculated for the experiment’s test environmental conditions. The calculations

were done in two ways: using only the air speed around the face, and using the average air speed of three heights next to the subjects: 0.1m, 0.6m, and at face level (1.1m). If the calculated indices represent the subject's responses well even under non-uniform flow and non-uniform clothing coverage, then the general use of a whole-body model is supported.

- 2) A number of published human subject experiments provide TSV results for other types of airflow sources and exposures of the body surface. These experiments involved airflow exposures to a variety of body parts that have differing thermal sensitivity (e.g. face vs. chest vs. back) (Arens E et al, 2006). Differences in subjects' thermal sensations should appear, even at the same air velocity. The regression relationship of TSV against SET value is therefore likely to differ among various types and extent of exposure.

2 Methods

2.1 Test of cooling under non-uniform air flow

A subjective experiment was conducted in a climate chamber in Tsinghua University in Beijing. 30 subjects took part in the experiment, experiencing warm environments with fan-generated frontal air flows to the face and upper body. They wore summer clothing of 0.57 clo. The temperature ranged from 28°C to 34°C with relative humidity 40%-50%. At each temperature, air speed ranged from 0.6 m/s to 2 m/s. All the fans were placed in front of the subjects at a horizontal distance of 0.6m and a vertical distance of 0.6m from the desk (Figure 1). The experiments were designed orthogonally with different temperatures and air speeds. Each experiment lasted about 2 hours at a fixed temperature. At the beginning, the subjects were given no air flow for 45 min, and then they voted their thermal sensation. After that, the fans provided air flows with four randomly sequenced speeds in turn, with each air flow lasting for 15 min, for a total duration of 60 min. Subjects' TSV were collected at the end of each 15-min period, using the ASHRAE seven-point thermal sensation scale (-3 cold, -2 cool, -1 slightly cool, 0 neutral, +1 slightly warm, +2 warm, +3 hot). Using the environmental parameters of each experiment, SET values for different conditions were calculated using the SET model and compared with the subjects' thermal sensation votes. The SET calculations were done using air speed measured in front of the face, 1.1m above the floor and 5 cm from the nose. Then they were repeated using the average speed of the three heights (0.1, 0.6, and 1.1m) to represent the whole-body air speed. Further details about this experiment are described in (Huang L et al, 2013).

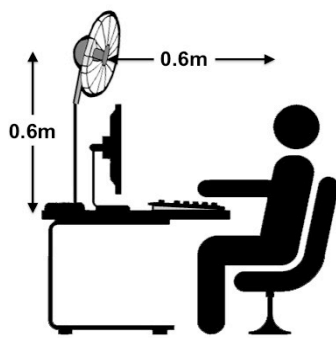

(a)



(b)

Figure 1. The relative position with the subject and fan

2.2 Studies of other air flow sources and exposure types

Table 1 shows published studies from which subjects' thermal sensation values could be obtained, and SET calculated. A variety of different air-movement devices are represented in the studies. We have categorized them as: ceiling fan, desk fan, tower fan, wind box, and nozzle. Subjects' exposures were to air flow on their head, back, and face/chest. SET could be calculated using the reported test conditions. The results are aggregated and compared with those of the fan study described above.

Table 1. Studies of air movement using different air movement devices

Researcher	Location	RH (%)	Local control	Air movement supply device	Body part directly exposed to the air
McIntyre D, 1978	UK	50	Yes	Ceiling fan	Head
Zhai Y, 2013	USA	60/80	No	Ceiling fan	Head
Fountain M et al, 1994	USA	50	Yes	Desk fan	Face and chest
Atthajariyakul S and Lertsatittanakorn C, 2008	Thailand	45-80	No	Desk fan	Face and chest
Chow TT et al, 2010	Hong Kong	50	No	Tower fan	Back
Tanabe S and Kimura K, 1994	Japan	50	Yes	Wind box	Back

Kubo H et al, 1997	Japan	50	Yes	Wind box	Front
Gong N et al, 2006	Singapore	40-55	No	Nozzle	Face
Yang B et al, 2010	Singapore	-	No	Nozzle	Head
Zhang H et al, 2010	USA	50	Yes	Nozzle	Head

3 Results

3.1 Suitable air flows at different temperatures

In the experiment, each subject was asked to report his or her thermal sensation by voting a scale on the seven-level ASHRAE thermal sensation scale.

As showed in Figure 2, each dot in the figure represents the average value of all the votes under the same environmental condition. At the same temperature, the thermal sensation vote turned lower as the air speed turned higher. But the differences of sensation votes between air flows of 1.5m/s and 2m/s were not so obvious, especially when the temperature reached 34°C. In warm environment, the air speed which makes the subjects' thermal sensation +0.5 can be defined as the lower limit of suitable air speed. According to Figure 2, the lower limit of air speeds for 28°C, 30°C, 32°C, 34°C was respectively identified as 0m/s, 1m/s, 2m/s, and over 2m/s.

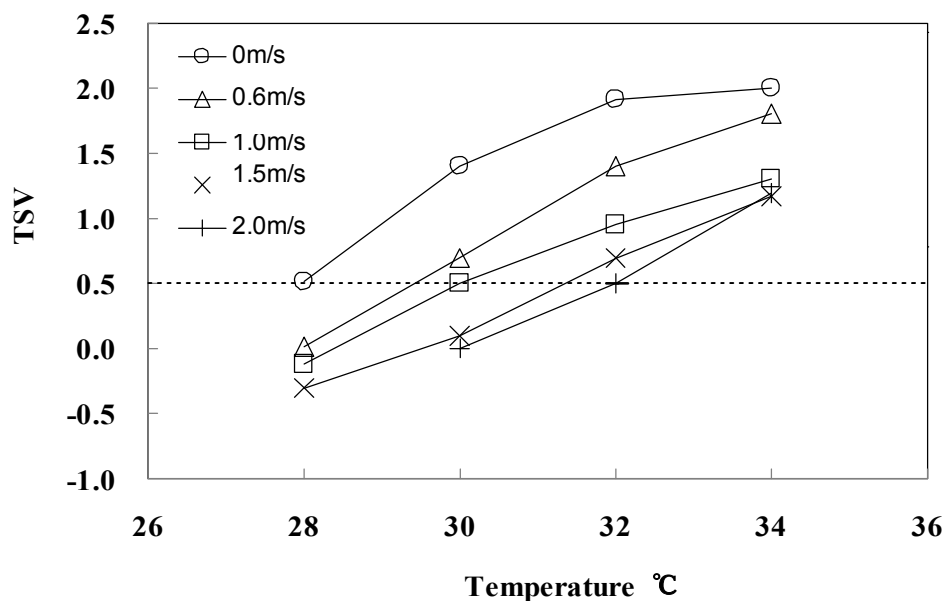

Figure 2. Thermal sensation votes for air speeds at different temperatures

3.2 Use of SET to represent spatially non-uniform air flow cooling

SET values were calculated for each set of environmental conditions in the human subject tests. SET was obtained from 2-Node as embodied in the ASHRAE Thermal Comfort Tool (Zhang H, 2003). Two air speeds were used as input: the airspeed in front of the face, and the average of the speed at three heights, 0.1, 0.6, and 1.1m. In each case the measurements had been taken 5cm in front of the body.

The regression of SET using the whole-body air speed against actual TSV is shown in Figure 3 (a). The SET value and TSV are linearly and closely related. It suggests that SET is a practical index for predicting human thermal sensation in warm environments, even under the non-uniform air flow conditions of this study.

The regression between SET and TSV using the air speed in front of the face (Figure 3 (b)) also shows them to be linearly and closely related. The slope is higher and the intercept is lower for the whole-body SET ($TSV=0.3106SET_{\text{whole-body}} - 8.1165$, $R^2=0.93$) than for the slope and intercept for SET using the air speed in front of the face ($TSV=0.2846SET_{\text{face}} - 7.1041$, $R^2=0.94$). This is because the latter uses a greater air speed to calculate the SET, overestimating the cooling effect and producing a lower slope and SET value. The comparison shows that it is fine to use either facial or whole-body-average air speed to calculate SET in order to predict thermal sensation, as long as the corresponding regression equation is used.

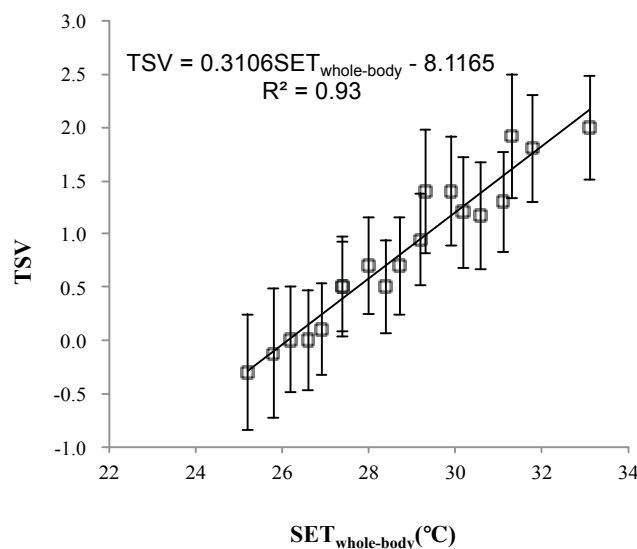

Figure 3. (a) Relationship between SET using the whole-body air speed and TSV

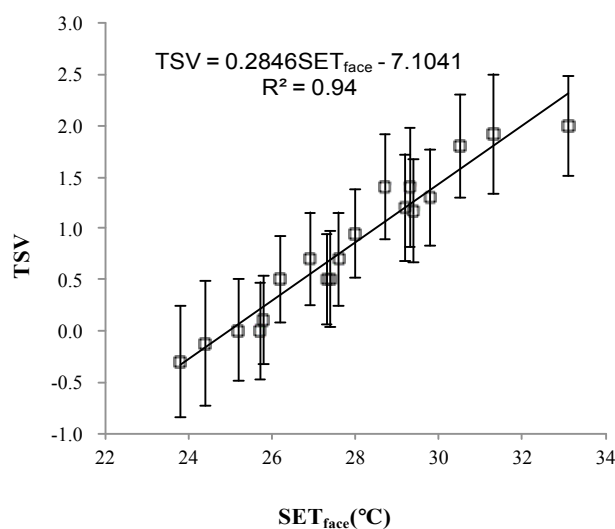

Figure 3. (b) Relationship between SET using the facial air speed and TSV

4 Discussion

4.1 The effect of local control of air speed

In the last step of each experiment session, each subject was asked to adjust the air speed produced by an electric fan till he or she obtained the most comfortable air flow. The thermal sensation votes for personally customized air speeds are shown in Figure 4. With local control of air speed, the thermal sensation was kept in a comfortable range.

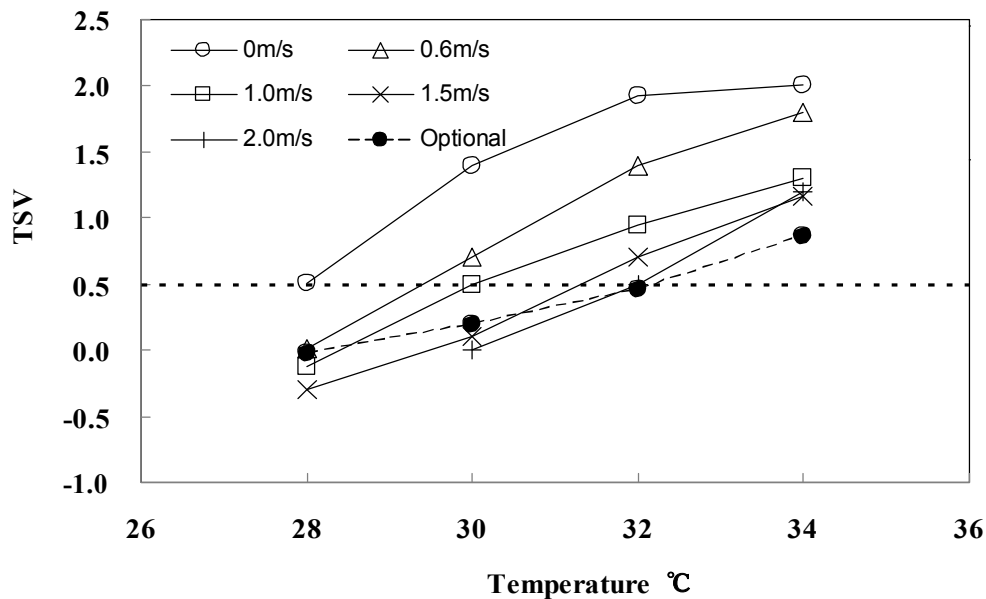

Figure 4. Thermal sensation votes for optional air speeds

Table 2 poses the subject's choices of preferred air speeds with those given by the researcher at the same thermal sensation scale. It shows that with the user's control of air speed, the same thermal sensation can be achieved with a lower speed. The adjustment capacity then improved the subject's thermal sensation to a measurable extent.

Table 2. The optional and given air speeds with the same thermal sensation

Temperature (°C)	TSV	Optional air speed (m/s)	Given air speed (m/s)
28	0	0.5	0.6
30	0.2	1.0	1.4
32	0.5	1.6	2
34	0.9	1.9	>2

The subjects' thermal comfort votes were recorded with a four-level scale from 0 to -3, representing the respective feeling of comfortable, slightly uncomfortable, uncomfortable, and very uncomfortable (Figure 5). The result showed that the subjects gave the highest thermal comfort votes when they could adjust the speed at will at each temperature level. Even at 34°C, the personally controllable air speed could maintain the user's thermal comfort state between "comfort" and "slightly uncomfortable".

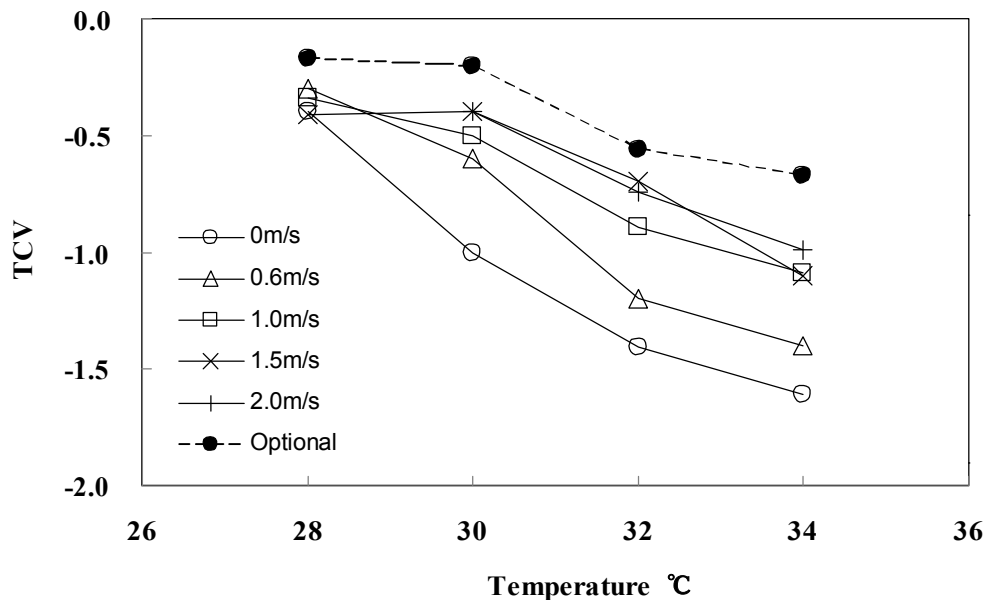

Figure 5. Thermal comfort votes with different air speeds

4.2 Airflow exposures to a variety of body parts

Figure 6 compares the results from this study with studies from the literature in which air temperature and air speed were tested orthogonally. These studies are listed in Table 1. The regression for the device category 'desk fan' is based on the test results from this study and from study (Atthajariyakul S and Lertsatittanakorn C, 2008) in Table 1. It indicates that thermal sensation differs by body part when exposed to the same air speed, which can be seen in the variation of TSV under the same SET. When the SET value was high-- ie, the air speed was low--the difference among the different modes of exposure was not so significant.

Subjects in experiments with their heads exposed to ceiling fans (Zhai Y, 2013) and jets (Yang B et al, 2010) had relatively warmer thermal sensation than subjects with chest and whole-body exposure. This may be because the top of the head exposes a smaller area to the air flow in ceiling fans and jets. The presence of hair may also be a factor. Comparing the ceiling fan and ceiling jet, the jet produced a warmer thermal sensation, again due to the smaller body area impacted. The face appears to be more sensitive to the cooling effect of air movement (Zhang H, 2003). For the experiment in which subjects' whole back was exposed to the air flow from a large-area wind box (Tanabe S and Kimura K, 1994), people had strong cool sensations because the exposed body area was larger than the other exposures.

Table 3 shows the differences in TSV-versus-SET regression coefficients for all these

exposure conditions. Statistical analysis shows significant pairwise differences between the regression lines (Table 4). The coefficient for whole-back cooling (0.37) is larger than the coefficient for the desk fan (0.33), ceiling fan (0.28), and ceiling jet (0.26), indicating that cooling effectiveness decreases in this order. In ASHRAE Standard 55, the cooling effect of air movement is calculated with SET, without reference to the type of exposure or wind source. From the analysis above it is seen that variation does exist between different exposures to air movement. However, for the most common airspeed sources (ceiling fan and desk fan), the variation of thermal sensation for a given SET is small (see the open diamonds and triangles in Figure 6). Only when SET is as low as 22°C, a temperature too cool for elevated airspeeds, does the variation between the ceiling fan and desk fan reach 0.5 in the thermal sensation scale (see Figure 6).

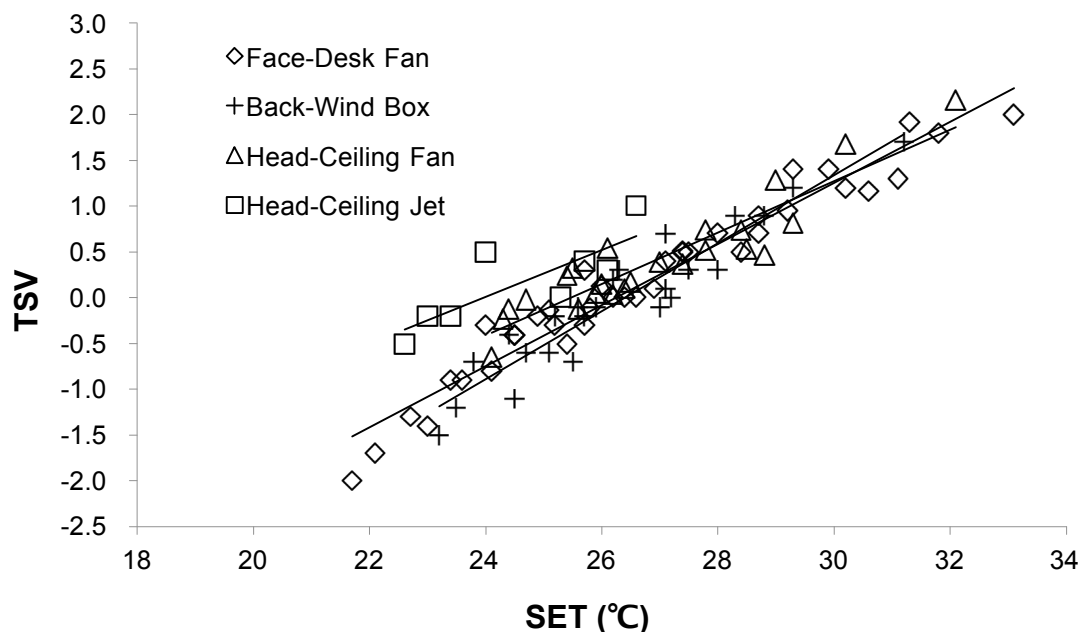

Figure 6. Relationship between TSV and SET in different experiments

Table 3. Linear regression equations of TSV and SET

Exposed body part-Air flow facility	Linear regression equation	R ²
Back - Wind Box (Tanabe S and Kimura K, 1994)	$TSV=0.37SET-9.82$	0.89
Face - Desk Fan (current &	$TSV=0.33SET-8.74$	0.95

Atthajariyakul S and Lertsatittanakorn C, 2008)		
Head - Ceiling Fan (Zhai Y, 2013)	TSV=0.28SET-7.15	0.85
Head - Ceiling Jet (Yang B et al, 2010)	TSV=0.26SET-6.12	0.66

Table 4. Pairwise statistical analysis between the linear regression equations of TSV and SET

Pairwise statistical analysis	p value for slope	p value for intercept
Wind Box - Desk Fan	0.188	0.036 *
Wind Box - Ceiling Fan	0.019 *	0.003 *
Wind Box - Ceiling Jet	0.119	0 *
Desk Fan - Ceiling Fan	0.057	0.006 *
Desk Fan - Ceiling Jet	0.199	0 *
Ceiling Fan - Ceiling Jet	0.715	0.002 *

* means significant pairwise difference ($p < 0.05$)

5 Conclusions

The climate chamber experimental study identified the lower limit of air speeds for 28°C, 30°C, 32°C was 0m/s, 1m/s, and 2m/s respectively. At 34°C none of the above air speeds could keep human thermal sensation below 0.5.

The above study also showed that the capacity to control an indoor environment could improve the subject's thermal comfort level and extend the acceptable range of thermal environment. When the user's personal control is available, the user would require lower air speed while achieving higher comfort level.

Although it is based on whole-body heat balance, the SET index can be used to predict thermal sensation for air movement that is not uniformly distributed across the body. The SET value and thermal sensation vote TSV are linearly well-related for a variety of non-uniform airflow distributions.

Fan airstreams impacting different body parts require different regression coefficients

for predicting TSV from SET. Representative coefficients are provided from an analysis of the existing literature on fan studies. However, the differences in cooling between substantially different types of fans are small. This can be seen in comparing the effects of ceiling fans (fan or jet) with desk fans.

References

- Arens E, et al., 2009. Moving Air For Comfort. *ASHRAE Journal*, 51(5), pp 18-28.
- Arens E, Gonzalez R, and Berglund LG, 1986. Thermal comfort under an extended range of environmental conditions. *ASHRAE Transactions*, 92, pp 18-26.
- Arens E, Zhang H, Huizenga C, 2006. Partial- and whole body thermal sensation and comfort, Part II: non-uniform environmental conditions. *Journal of Thermal Biology*, 31, pp 60-62.
- Atthajariyakul S and Lertsatittanakorn C, 2008. Small fan assisted air conditioner for thermal comfort and energy saving in Thailand. *Energy Conversion and Management*, 49(10), pp 2499-2504.
- Aynsley R, 2008. Quantifying the Cooling Sensation of Air Movement. *International Journal of Ventilation*, 7(1), pp 67-76.
- Berglund LG, Stolwijk JAJ, 1978. The use of simulation models of human thermoregulation in assessing acceptability of complex dynamic thermal environments. *Energy Conservation Strategies in Buildings*, ed. J.A.J. Stolwijk. New Haven.
- Cândido C, de Dear RJ, Lamberts R, 2011. Combined thermal acceptability and air movement assessments in a hot humid climate. *Building and Environment*, 46, pp 379-385.
- Chow TT, et al., 2010. Thermal sensation of Hong Kong people with increased air speed, temperature and humidity in air-conditioned environment. *Building and Environment*, 45(10), pp 2177-2183.
- de Dear RJ, 1998. A global database of thermal comfort field experiments. *ASHRAE Transactions*, 104 (1b), pp 1141-1152.
- Fountain M and Arens E, 1993. Air movement and thermal comfort. *ASHRAE Journal*, 35(8), pp 26-30.
- Fountain M, et al., 1994. Locally controlled air movement preferred in warm isothermal environments. *ASHRAE Transactions*, 100(2), pp 937-952.
- Gagge AP, Fobelets AP, and Berglund LG, 1986. A standard predictive index of human response to the thermal environment. *ASHRAE Transactions*, 92, pp 709-731.
- Gagge AP, Stolwijk JAJ, Nishi Y, 1972. An effective temperature scale based on a simple model of human physiological regulatory response. *ASHRAE Transactions*, 77, pp 21-36.
- Gong N, et al., 2006. The Acceptable Air Velocity Range for Local Air Movement in

- The Tropics. *Hvac&r Research*, 12(4), pp 1065-1076.
- Huang L, et al., 2013. A study about the demand for air movement in warm environment. *Building and Environment*, 61(0), pp 27-33.
- Kubo H, Isoda N, and Enomoto-Koshimizu H, 1997. Cooling effects of preferred air velocity in muggy conditions. *Building and Environment*, 32(3), pp 211-218.
- McIntyre D, 1978. Preferred air speeds for comfort in warm conditions. *ASHRAE Transactions*, 84(2), pp 264-277.
- Tanabe S, Kimura K, 1994. Effects of air temperature, humidity and air movement on thermal comfort under hot and humid conditions. *ASHRAE Transactions*, 100(22), pp 953-969.
- Toftum J, 2004. Air movement – good or bad? *Indoor Air*, 14, pp 40-45.
- Yang B, Sekhar SC, and Melikov AK, 2010. Ceiling-mounted personalized ventilation system integrated with a secondary air distribution system - a human response study in hot and humid climate. *Indoor Air*, 20(4), pp 309-319.
- Zhai, Y, 2013. *Low energy comfort with air movement in hot-humid environments*. PhD. South China University of Technology.
- Zhang H, et al., 2007. Air movement preferences observed in office buildings. *International Journal of Biometeorology*, 51, pp 349–360.
- Zhang H, et al., 2010. Comfort, perceived air quality, and work performance in a low-power task–ambient conditioning system. *Building and Environment*, 45(1), pp 29-39.
- Zhang H, 2003. Human thermal sensation and comfort in transient and non-uniform thermal environments. *CEDR 2003*, University of California at Berkeley.
- Zhou X, Ouyang Q, Lin G and Zhu Y, 2006. Impact of dynamic airflow on human thermal response. *Indoor Air*, 16(5), pp 348-355.

Comfort temperature and the adaptive use of environmental controls in offices in Japan

Ryozo Ooka¹, Madhavi Indraganti² and Hom B Rijal³

¹ Department of Human and Social Systems, Institute of Industrial Science
4-6-1, Komaba, Meguro-ku, The University of Tokyo, Tokyo 153-8505, Japan

² Fulbright- Nehru Post-doctoral Researcher
Center for the Built Environment, University of California, Berkeley
390 Wurster Hall, Berkeley, USA

³ Department of Restoration Ecology & Built Environment, Tokyo City University,
Yokohama, Japan

¹ ooka@iis.u-tokyo.ac.jp

² main@berkeley.edu , maindraganti@gmail.com

³ rijal@tcu.ac.jp

Abstract

Japan's energy perspective underwent a paradigm shift after the 2011 earthquake. It put in place the 'setsuden' (energy saving) campaign. This recommended minimum and maximum temperature settings for summer and winter, without enough empirical evidence. Many large offices adhered to these, often running them in naturally ventilated (NV) mode. In this context, we surveyed four buildings in Tokyo in summer 2012. About 435 participants provided 2042 sets of data. It contained thermal responses, simultaneous environmental recordings and observations on the use of controls. This paper discusses the comfort temperature and focuses on the occupant behaviour. We found the comfort temperature to be 27.0 °C and 27.4 °C in NV and air-conditioned (AC) modes respectively. Occupants adaptively operated the windows, doors and fans. Logistic regression predicted 80% fan usage at 28 °C of indoor temperature. Offices in AC mode had higher CO₂ level. Many design, operational and behavioural factors hindered adaptive control operation.

Keywords: Thermal comfort; Japan; Occupant behaviour; Adaptive model; Window opening

1 Introduction

The Great Eastern Earthquake and the Tsunami in 2011 have not only caused havoc in Japan, but also rattled the energy conscience of the nation and the world at large. Thereafter, Japan's energy perspective underwent a paradigm shift. Nuclear energy fulfils about 8% of Japan's energy needs (EIA, 2013). With many nuclear plants being shut down after the Fukushima nuclear disaster, Japan faced nation-wide power shortages. These had serious economic consequences for a highly industrialised nation, calling for enormous energy savings. As a fallout, Japan implemented an unprecedented 'setsuden' (energy saving) campaign in May 2011.

1.1 The setsuden campaign

Under this, large consumers were mandated to reduce the peak-power consumption by 15%, while smaller consumers were asked to adhere to 15% reduction in 201. These mandates were translated into two 'minimum and maximum thermostat settings of 28 °C in summer and

20 °C in winter' respectively. Unfortunately, these dictates seem to be arbitrary and are not supported by solid empirical evidence.

The *setsuden* efforts in the summer 2011 yielded 18% power savings in Tokyo (Ministry of Economy, Trade, and Industry, Japan, 2011). Tanabe et al. discussed in detail, the occupant comfort satisfaction and productivity in offices operating under the *setsuden* conditions in 2011 (Tanabe, et al., 2013).

From a mandatory level, the *setsuden* norms have been changed to a recommendatory level in 2012. Thus, most large scale establishments continued to stick to these, albeit in a relaxed manner. It resulted in offices voluntarily switching off air-conditioning (AC) systems for certain hours and running the offices in naturally ventilated mode (NV) in summer. A field study conducted in summer 2012 clarified on the thermal comfort under the changed scenario in offices (Indraganti, et al., 2013).

Running offices satisfactorily at higher than regular indoor temperatures implies occupant's adaptation through the use of various environmental controls. However, current literature has very little on the occupant adaptation in offices in Japan, while Rijal et al focussed on the user behaviour and adaptation in residential environments (Rijal, et al., 2013).

Interestingly, the studies conducted during 2003 – 2005, i.e., prior to the Fukushima crisis observed no influence of the adaptive opportunity on the thermal perceptions across buildings (Goto, et al., 2007). Therefore, this paper aims to highlight the user behaviour in using various adaptive controls in offices in Japan. It also briefly explains the comfort temperature as noted through a field study in Tokyo, Japan in 2012 summer.

2 Methods

Tokyo lies on humid subtropical climate zone. We conducted a thermal comfort field survey in 88 office spaces in four office buildings of The Tokyo University, in Tokyo during the months of July – September in 2012. The survey was scheduled to include the months of highest discomfort.



Figure 1. Typical survey environments, measurement setup and typical female clothing ensembles; (A) Omnidirectional probe anemometer (Kanomax Climomaster 6531), (B) Thermo-hygro-CO₂ meter (TR-76Ui), (C) Globe thermometer (TR-52i)

Large play fields and landscaped areas surrounded the surveyed buildings. These are 20 - 30 years old concrete framed structures in two to nine floors. While the lower three floors have concrete in-fill panelled walls, the upper floors have wood and aluminium panelled walls. Most of the spaces have sash or vertically pivoted or sliding windows. Some spaces have balconies with doors too. In most cases the doors opened into the naturally ventilated corridors. All of these buildings were probably designed to operate as AC buildings throughout their service life. Therefore, majority of the windows or doors were not possibly fitted with any shading or rain protection devices. Most of them have operable windows.

This is a paper based survey. Each of the office was visited twice or thrice a day, leaving a minimum gap of two hours in between. The second author interviewed all the 435 voluntary participants. She gathered 2402 sets of data. This data consisted of thermal responses, simultaneous recordings of environmental measurements and her observations about the subject's clothing, activity and use of various environmental controls. The controls observed were: windows, doors, common and personal fans, general and personal table lights and AC systems. Venetian blinds and rolling screens or traditional bamboo screens are fitted to all the windows and balcony doors.

We used calibrated high-precision digital instruments following the American Society of Heating Refrigeration and Air-conditioning Engineers (ASHRAE)'s Class-II protocols for field survey (ASHRAE, 2010). The typical survey environments, instrument set-up and the clothing ensembles used by women subjects are presented in Fig. 1.

The subject sample included 290 males. They are in the age group of 20 – 70 years. Men provided 51.2% of the data. About 22.1% the subjects were non-Japanese occupants. We estimated the clothing insulation of the subjects' ensembles using the summation method and standard lists (ASHRAE, 2010). Most of the subjects followed the 'coolbiz' suggestions and were in light summer clothing (mean clo = 0.63 clo, SD = 0.08). We did not observe any significant gender or modal differences in the total clothing insulation. A detailed account on the methods and the subject sample is in Indraganti et al. (Indraganti, et al., 2013).

3 Results and Discussion

3.1 Thermal conditions and comfort responses

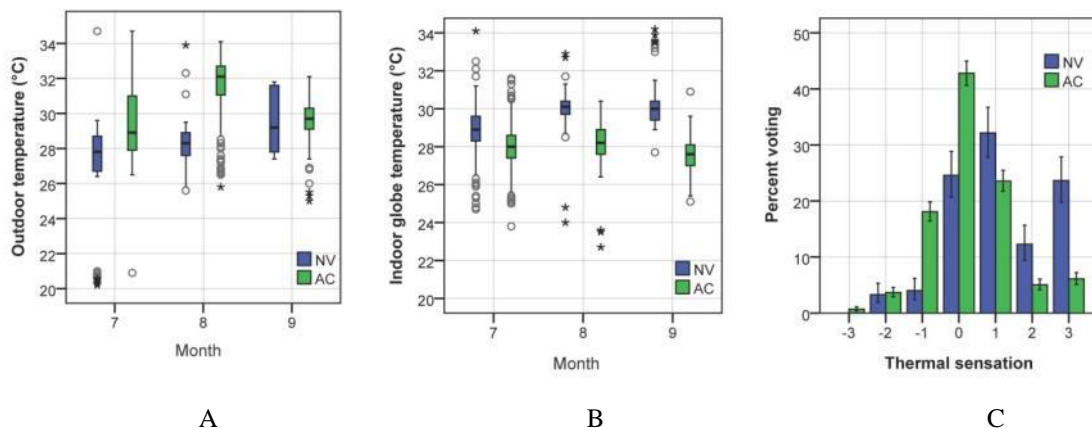

Figure 2. Box-plots of outdoor and indoor globe temperatures and thermal sensation in NV and AC modes

Outdoor temperature during the three months of survey varied from 20.2 °C to 34.7 °C, with 29.7 °C as mean (standard deviation (SD) = 2.49 K). Outdoor humidity remained quite high throughout the survey averaging at 63.5% and ranged from 41% to 93%. The survey lasted from July 4 to September 11. Warm-humid summer conditions with intense discomfort prevailed throughout the survey.

Indoor conditions and temporal variations

Due to the *setsuden* requirements most of the offices operated their AC systems adaptively, probably when it was hot outside. They functioned in NV mode rest of the time (usually in the morning and in the evening). Our study included both these modes of operation. The survey continued from morning till late in the evening on all the survey days. Each of the comfort response and the simultaneous recording of the temperature are noted against the voting time. All the voting times are ranked and divided into ten equal interval groups of approximately equal sample size (deciles) using the statistical package SPSS ver. 20. Figure 3

shows the temporal variation in indoor globe temperature observed during the three months of survey. It shows on the x-axis mean voting time of the decile group, and the mean indoor globe temperature at that time as observed in the field. It can be seen that temperature in NV mode fluctuated more during the day.

Indoor globe temperature (T_g) was less variable compared to the outdoor temperature (Figure 2B). Hygro-thermal conditions in NV mode were more variable than in AC mode. In NV mode, mean T_g was 29.4 °C (N = 423, SD = 1.5 K) and in AC mode it was slightly lower averaging at 27.9 °C (N = 1979, SD = 1.2 K). Similarly, the mean indoor relative humidity was 52.6 % (SD = 6.4%) and 50.9 % (SD = 4.4%) in NV and AC modes respectively. Air velocity in AC mode was slightly higher than NV. The median of air velocity in AC mode was 0.21 m/s while it was 0.18 m/s in NV mode.

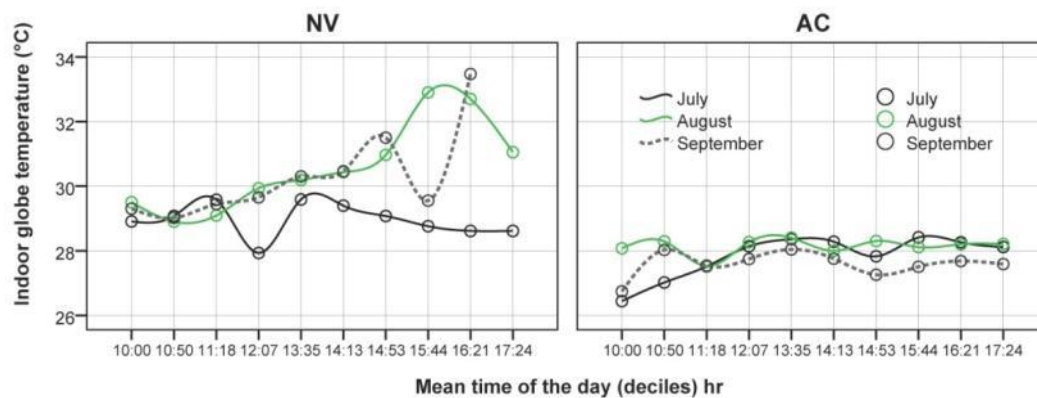

Figure 3. Temporal variation in the indoor globe temperature during the three months of survey

Thermal sensation (TS)

We measured the thermal sensation on ASHRAE’s seven point scale. A significantly higher percentage of people voted on the warmer side of the scale in the NV mode than in AC mode at 95% confidence interval (CI) (Fig. 2C). In NV mode only 69.1 % were comfortable (voting between -1 to +1) and in AC mode 84.4 %. About 31.9% and 65.3% felt ‘neutral’ sensation in NV and AC modes respectively. Mean sensation in NV mode was 1.17 (SD = 1.3) and AC mode was 0.24 (SD = 1.2).

In a 2011 summer (July through August) study in Tokyo offices, Tanabe et al. noted greater variability in the mean sensation vote. They found it varying between -0.7 (SD = 1.1) to 2.0 (SD = 1.3). They noted the mean indoor air temperature varying between 25.3 °C (SD = 0.3 K) and 29 °C (SD = 0.9 K), while the relative humidity varied between 46 – 60% (Tanabe, et al., 2013).

Comfort temperature (T_{comf})

We estimated the comfort temperature (T_{comf}) by Griffiths’ method using 0.5 as the Griffith’s coefficient (G) using the following relationship (Griffiths, 1990):

$$T_{comf} = T_g + (0 - TS) / G \dots\dots\dots(1)$$

Figure 4 shows the distribution of the comfort temperature. Mean comfort temperature was found to be 27.0 °C in NV mode and about half a degree higher in AC mode (27.4 °C). Temperature and humidity in NV environments are significantly higher than those of AC mode. Absolute humidity is 13.4 g/kg.da and 11.9 g/kg.da in NV and AC modes respectively. Occupants in AC mode also have achieved higher air movement by using fans. This in part explains the higher comfort temperature in AC mode as observed here.

The running mean of the outdoor temperature better explains the effects of outdoor conditions on the indoors (Humphreys, et al., 2013). The running mean of the outdoor mean temperature was estimated for all the data sets using the relationship,

$$T_{rm} \text{ (tomorrow)} = (\alpha) T_{rm} \text{ (yesterday)} + (1-\alpha) T_m \text{ (today)} \dots\dots\dots(2)$$

Where, T_{rm} is the running mean temperature ($^{\circ}\text{C}$), T_m is the outdoor daily mean temperature ($^{\circ}\text{C}$), and α is a unit less constant between 0 and 1 and is usually taken as 0.8. It indicates a half-life of approximately 3.5 days (Humphreys, et al., 2013).

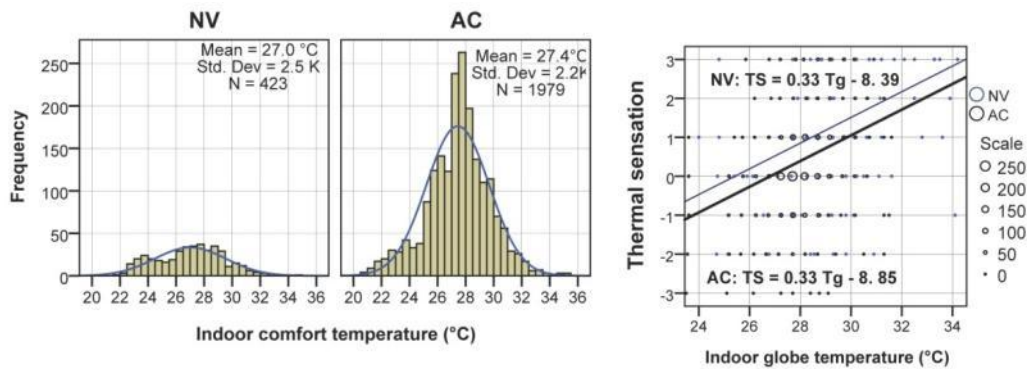

Figure 4. Comfort temperature distribution in NV and AC modes and regression of indoor globe temperature with the thermal sensation ($p < 0.001$)

The occupant’s thermal sensation varied with the indoor globe temperature. However, the slope of the equation for NV mode was not significantly different from the AC mode, although both the relationships were themselves significant. Hence, we used the general linear regression model which assumes equal slope for both the categories (NV and AC) using ‘mode’ as the fixed variable, and obtained the following relationships ($p < 0.001$):

$$\text{NV Mode: } TS = 0.33 T_g - 8.39 \dots\dots\dots(3)$$

$$\text{AC Mode: } TS = 0.33 T_g - 8.85 \dots\dots\dots(4)$$

Using these equations, the neutral temperature (coinciding with ‘0’ on the sensation scale) was found to be 25.4 $^{\circ}\text{C}$ and 26.8 $^{\circ}\text{C}$ in NV and AC modes respectively.

3.2 The Adaptive model

NV mode

An adaptive relationship was noted between indoor and outdoor temperatures as shown in the Figure 5A. It shows the variation in monthly mean indoor globe temperature (T_{gmm}) with monthly mean outdoor temperature (T_{omm}) for both NV and AC modes. The gradient of the relationship (slope = 0.35 K^{-1}) for NV mode matched very closely with the slope of the ASHRAE’s adaptive model (slope = 0.31 K^{-1}) (de Dear & Brager, 1998). The comfort temperature and outdoor mean temperature relationship as observed in Japan by Goto et al. was also above the ASHRAE’s adaptive model (Goto, et al., 2007).

European standards (CEN:15251, 2007) mention a similar relationship, where the slope of the equation between outdoor daily running mean temperature and indoor comfort temperature is 0.33 K^{-1} . It appears that the subjects’ comfort responses in European and Japanese offices are very similar to one another.

AC mode

In AC mode, we observed the indoor comfort temperature changing significantly with the outdoor daily running mean temperature as shown in Figure 5B. The following equation was obtained:

$$T_{\text{comf}} = 0.10 T_{\text{rm}} + 24.80 \dots\dots\dots(5)$$

(N = 1979, r = 0.30, S.E. = 0.032, p=0.003)

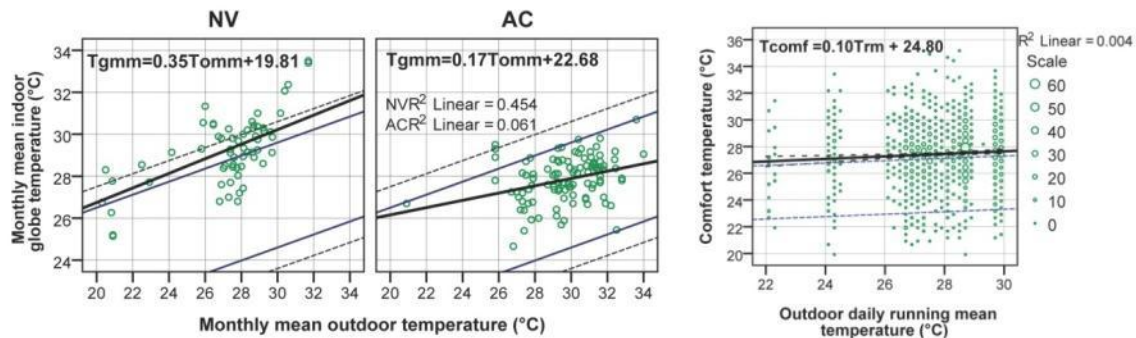

Figure 5. (A) An adaptive relationship between T_{omn} and T_{gmm} for NV and AC modes ($p < 0.001$); Also shown superimposed are the 90% and 80% limits of the ASHRAE's adaptive model; Each point represents the aggregated monthly data for an office; (B) A similar relationship between T_{rm} and T_{comf} ($p < 0.01$), superimposed with the upper and lower limits of a similar model from the CIBSE guide; Dotted lines indicate 95% CI of slope; Each point is a single dataset.

Nevertheless, we could not find a significant relationship in NV mode. As the quantity of data was very limited, we could not get a meaningful significance. Figure 5B shows the relationship from the CIBSE guide, which is based on the surveys in European offices (CIBSE, (The Chartered Institution of Building Services Engineers, 2006; Nicol & Humphreys, 2007).

Interestingly the slope of the regression line from this study (0.1 K^{-1}) matched very closely with the slope of the line from the European data (0.09 K^{-1}). It is also comparable to the slope of the equation (0.15 K^{-1}) obtained in Indian offices in AC mode (Indraganti, et al., 2014). A large scale residential building study in Japan reported a slope of 0.297 K^{-1} in AC mode (Rijal, et al., 2013). It points to a very high variability in comfort temperature in homes, for a step change in outdoor temperature, also indicating high occupant adaptation in residential spaces.

However, both the regression lines in NV and AC modes lie very close to the upper limits of the ASHRAE's adaptive model and CIBSE's model respectively, while the slopes matched very closely (Figure 5A, B). This indicates occupant adaptation at higher indoor temperatures, generally observed in Japanese offices. The following sections explain this.

3.3 Occupants' adaptive behaviour

We noted various environmental controls put to use in this summer study. The controls observed were windows, doors, blinds, fans and hand fans. Occupants used many kinds of fans: floor mounted high power fans, floor mounted and table mounted tower fans, small table fans, very small USB (universal serial bus) fans and hand fans.

During the field survey we recorded the use of a fan as binary data (0 = not in use; 1= in use). They are noted down as general fans and personal fans. In this study the use of fan includes both personal and general fans. Similar to the fans, windows, doors and blinds are noted down as binary data (0 = closed, 1 = open). Table 1 shows the mean proportion of use of controls in NV and AC modes as observed in various offices.

When the indoor temperature exceeds the comfort temperature occupants make use of the environmental controls to restore thermal comfort. Many researchers found empirical evidence for this (Brager, et al., 2004; Rijal, et al., 2008; Rijal, et al., 2007). Temperature seems to be key stimulus to the operation of controls. Greater use of controls is expected at higher temperature.

Table 1: Mean proportion of use of controls

Mode	Building	N	Windows open	Doors open	N	Fans on
NV	AS	4	0.50	1.00	4	0.25
	IIS	419	0.84	0.78	316	0.67
All NV		423	0.83	0.78	320	0.66
AC	AS	27	0.19	0.00	27	0.15
	IIS	1790	0.00	0.01	1500	0.78
	K1	160	0.04	0.00	160	0.96
	KL	2	0.00	0.00	2	0.00
All AC		1979	0.01	0.01	1689	0.79

N = Number of observations

While all the surveyed offices have windows and doors, some of the spaces surveyed do not have fans. Table 1 presents the proportion of use of controls in each of the surveyed building in both NV and AC modes. As can be observed, we found the windows open in 83% of the cases and 78% doors open in NV mode. The use of windows and doors was very limited in AC mode. Therefore, these two controls are analysed in NV mode while the use of fans is examined in both the modes.

Table 2: Changes in indoor environmental variables with the use of windows and doors (NV mode)

Environmental variable	Windows closed		Windows open	
	Door closed	Door open	Door closed	Door open
Sample size	29	39	63	290
Outdoor air temperature (°C)	28.0	26.6	28.8	27.3
Comfort temperature (°C)	27.2	25.8	28.0	26.9
Indoor air temperature (°C)	28.9	29.1	30.2	29.2
Indoor globe temperature (°C)	28.9	28.9	30.1	29.3
Air velocity (m/s)	0.24	0.18	0.14	0.21
Relative humidity (%)	50.7	59.5	49.9	52.5
Humidity ratio (g/kgda)	12.5	15.1	13.3	13.2
CO2 level (ppm)	889	610	643	577
Fan usage (%)	0.76	0.69	0.67	0.65

The data are ranked and binned into quartiles of indoor and outdoor temperatures, containing roughly equal number of samples. Figure 6 shows the proportion of open windows, open doors, open blinds and ‘fans on’ in NV mode in each of the temperature bins with 95% CI. The proportion of open windows, open blinds and fans in use increased with temperature. The proportion of ‘doors open’ remains quite high throughout at around 83%, where as the window usage varied from 77% to 90%.

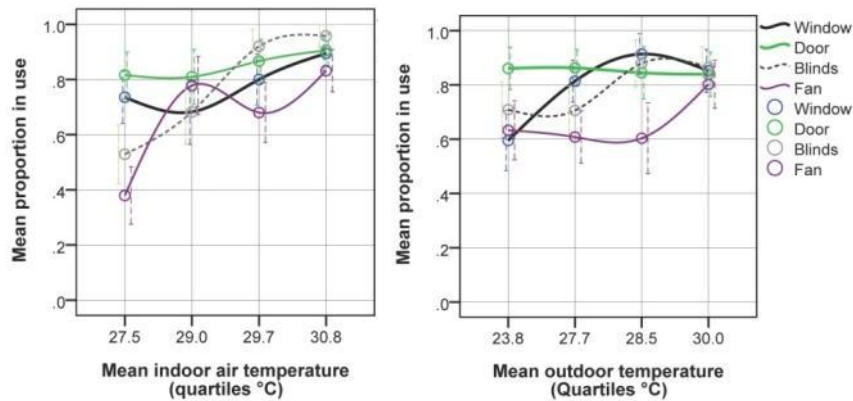

Figure 6. Proportion of windows open, doors open, blinds open and fans on with 95% CI at quartiles of indoor air temperature and outdoor mean temperature

Order of priority between the use of controls

We noted a complex inter-relationship/ dependency among the use of controls. It is generally believed and there is some field study evidence from Pakistan, that occupants open the windows and doors as a first reaction (Rijal, et al., 2008). We found this hypothesis applying to our data as well. For example, a closer look at Figure 6 reveals that at lower outdoor or indoor temperatures, the proportion of usage is lowest for fans, medium for windows and highest for doors.

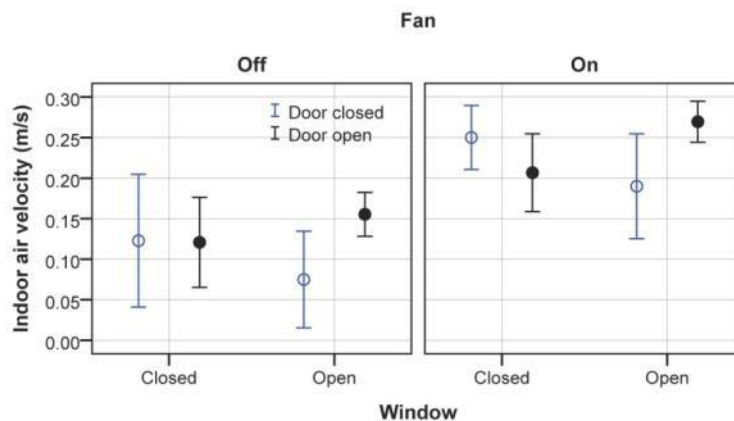

Figure 7. Indoor air velocity when windows, doors and fans are in use with 95% CI in NV mode

Use of windows and doors has also impacted the indoor environment as shown in Table 2 and Table 3. In general, we noticed doors and windows being open in conditions where indoor temperatures and humidity were high. Moreover, the occupants perhaps preferred to close the windows and doors when the outdoor temperature is very high and use of the fans is more. This is indicated by higher proportion of 'fans on', when both windows and doors were closed.

In addition, perhaps as the fans were used more, the subjects successfully achieved higher mean indoor airspeeds even when the doors and windows were closed, than when they both were open (Figure 7). As a result, the mean indoor comfort temperature is also slightly higher with both doors and windows closed than otherwise. It is to be noted that this difference is not statistically significant at 95% CI.

The combined effect of windows, doors and fans on indoor air speeds is profound. Operation of controls increased the mean air movement to about 0.27 m/s. Figure 7 shows the air speeds

when the three controls are operated in NV mode with 95% CI. Significantly higher indoor air speeds are noted when fans were ‘on’ and windows and doors were open, than otherwise.

It also important to note that use of doors and windows posed many operational and spatial constraints.

As a result, a mere thermal stimulus perhaps was not sufficient for their complete operation. These constraints would be discussed subsequently. As can be seen in the Table 3, window usage correlated rather poorly with the temperature. On the other hand, door usage correlated negatively with the temperature. It is likely that people preferred to close the doors at high temperatures, and used fans and windows to provide for the necessary air movement. Fan usage showed a much stronger positive correlation in both the modes with temperature.

Table 3: Correlations of usage of controls with indoor and outdoor environmental variables

Mode	Control	N	T _m : control	T _o : control	T _a : control	T _g : control	V _a : control
NV	Window	423	-0.02	0.06	0.08	0.13**	-0.01
NV	Door	423	-0.23**	-0.19**	-0.18**	-0.11*	0.10*
NV	Fan	320	0.37**	0.27**	0.27**	0.23**	0.36**
AC	Fan	1689	0.12**	0.07**	0.12**	0.09**	0.29**

** . Correlation is significant at the 0.01 level (2-tailed); * . Correlation is significant at the 0.05 level (2-tailed). T_m: Outdoor daily mean temperature (°C); T_o: outdoor temperature (°C); T_a: indoor air temperature (°C); T_g: indoor globe temperature (°C); indoor air velocity (m/s)

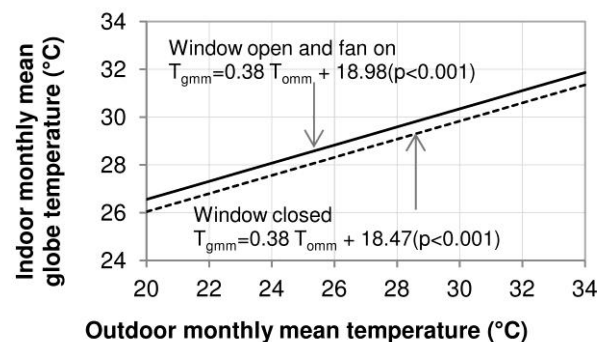

Figure 8. Relationship between indoor and outdoor temperatures with windows open and fan on and windows closed ($p < 0.001$)

Open windows and fans in use had a positive effect on the indoor temperature in NV mode by improving thermal comfort and the fans in use had a similar effect in AC mode. Figure 8 shows the regression between outdoor temperature and indoor globe temperature aggregated over a month for each of the offices in NV mode. The two lines are the general linear regression lines indicating equal slope, and varying y-intercepts caused by the use of fan and window. The difference is statistically significant at $p < 0.001$. It means that the subjects had a higher indoor mean temperature when using open windows and fans than when they both were not in use.

Algorithm to predict the use of fans

The contribution of fans to improve the indoor air velocity and thereby comfort at warm temperatures is well known (Rijal, et al., 2008; Rijal, et al., 2007; Rijal, et al., 2013; Indraganti, et al., 2014). Algorithms to predict the fan usage are useful in simulation studies.

Nicol mentions that a stochastic relationship better explains the association between fan usage and the indoor/ outdoor temperature (Nicol, 2001). For example, the probability of fan being in use (P_f) against an external stimulus such as indoor/ outdoor air temperature (T_a) can be examined. Logistic regression is widely used for this (Haldi & Robinson, 2008; Rijal, et al., 2008; Rijal, et al., 2013; Indraganti, et al., 2014; Yun & Steemers, 2008).

The logit is given by the equation:

$$\text{Logit } (p) = \log (p/(1-p)) = bT+c \dots\dots\dots(6)$$

Where,

$$p = e^{(bT+c)} / (1+e^{(bT+c)}) \dots\dots\dots(7)$$

Where p is the probability that the fan being on, T is the temperature (in this case indoor air temperature), b is the regression coefficient for T , and c is the constant in the regression equation.

The logistic regression of P_f and indoor air temperature (T_a) yielded the following equations with the following standard error of slope (SE) and Negelkerke R^2 values:

$$\text{NV mode: } \text{logit } (p) = 0.441 T_a - 12.18 \dots\dots\dots(8)$$

($N= 320$; $R^2 = 0.101$; $SE = 0.096$, $p<0.001$)

$$\text{AC mode: } \text{logit } (p) = 0.277 T_a - 6.38 \dots\dots\dots(9)$$

($N= 1689$; $R^2 = 0.021$; $SE = 0.058$, $p<0.001$)

Similarly, the logistic regression of P_f and outdoor daily mean temperature (T_m) yielded the following equation with the following standard error of slope (SE) and Negelkerke R^2 values:

$$\text{NV mode: } \text{logit } (p) = 0.422 T_m - 10.19 \dots\dots\dots(10)$$

($N= 423$; $R^2 = 0.179$; $SE = 0.073$, $p<0.001$)

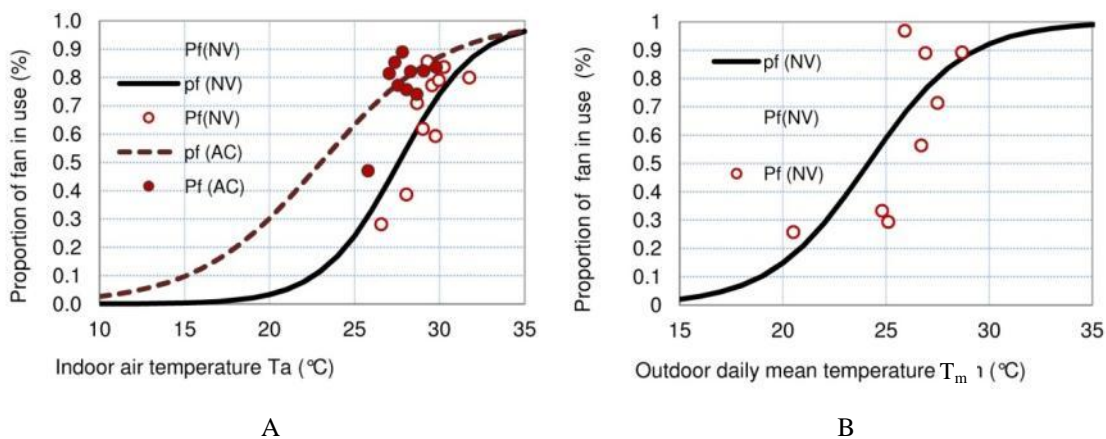

Figure 9. Logistic regression of proportion of fans in use with (A) indoor air temperature (B) outdoor daily mean temperature with actual data superimposed for both NV and AC modes ($p<0.001$). Each point is from aggregated from ranked deciles of temperature.

These equations (8) and (9) are shown in Figure 9A and equation (10) in Figure 9B, with binned data from the field study superimposed on them. The actual data matches the regression line well. Using this equation we can estimate that at an indoor air temperature of 28 °C, about 80% fans would be running.

These equations matched closely with the findings from other reports. Pakistan survey reported a slope of 0.426 (with Cox and Snell R^2 of 0.48) for the logistic regression of indoor globe temperature and fan usage in NV mode. Their equation also predicted 75% fan usage at 28 °C of globe temperature (Rijal, et al., 2008). An Indian field study in summer obtained a logistic regression coefficient of 0.448 when the fan usage was regressed with indoor globe temperature (Indraganti, et al., 2013). They predicted 80% fans to be in use when the indoor temperature would be at 29 °C.

3.3 Indoor CO₂ level and the thermal effect on productivity

Indoor CO₂ level depended very heavily on the use of openings. It was significantly lower in NV mode when the windows and doors were open than it is in AC mode (at 95% CI). We enquired all the subjects about the thermal effect on their productivity (TPR) on a five point equal interval scale. The scale had '0' in the center indicating 'no effect'. The scale points +2 and -2 referred to 'much higher than normal' and 'much lower than normal' productivity respectively.

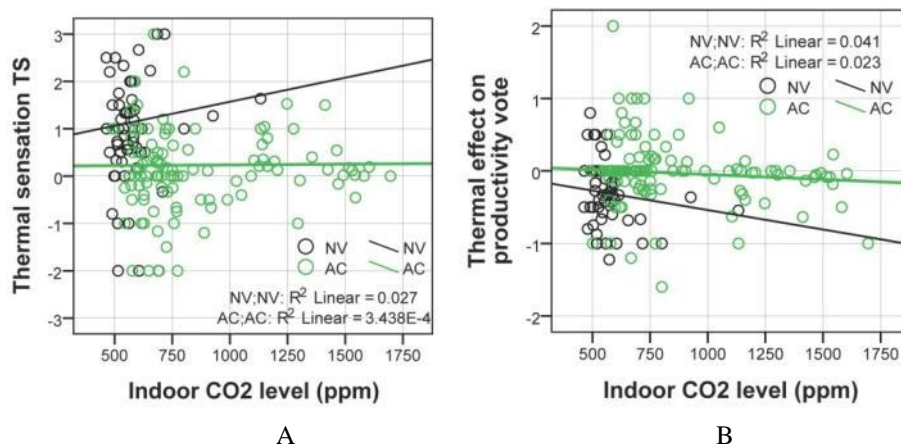

Figure 10. Variation in (A) thermal sensation (B) thermal effect on productivity vote with indoor CO₂ for both NV and AC modes. Each point represents the aggregated monthly data from an office.

We aggregated the TS, TPR and CO₂ level data for all the offices in all the months for both the modes. We then regressed the mean data. This is shown in Figure 10. It appears that an increase in CO₂ concentration has clearly elevated the thermal sensation vote in NV mode while it had little effect in AC mode. Similarly, at higher CO₂ levels, subjects voted their self declared productivity to be lower than normal in NV mode, while in AC mode the difference is marginal.

Increased CO₂ concentrations usually occurred in NV mode when the doors and windows were closed. This perhaps could have increased the indoor temperatures also, leading a higher sensation vote, causing discomfort in turn. This thermal discomfort also could have affected the occupant's productivity vote. This in part explains higher TS and lower TPR votes at higher CO₂ levels. Tanabe et al also have observed lower satisfaction levels at higher CO₂ levels in a Japan study (Tanabe, et al., 2013).

4 Obstacles in successful operation of controls

We noted many hindrances to the successful operation of environmental controls like windows, doors, blinds and fans. While some of these are related to the design, operation and maintenance factors, others are borne out of occupants' thermal history and other behavioural issues. These are discussed here very briefly.

4.1 Design factors

Majority of the offices surveyed were designed to be run with the help of active systems like air conditioners throughout their service life. Perhaps the design indoor temperatures were much lower than the temperature settings of the *setuden* for summer (28 °C). As a result, a majority of the buildings were not fitted with well designed operable windows or ceiling fans. Most of the windows and balcony doors lacked shading devices (Figure 11).

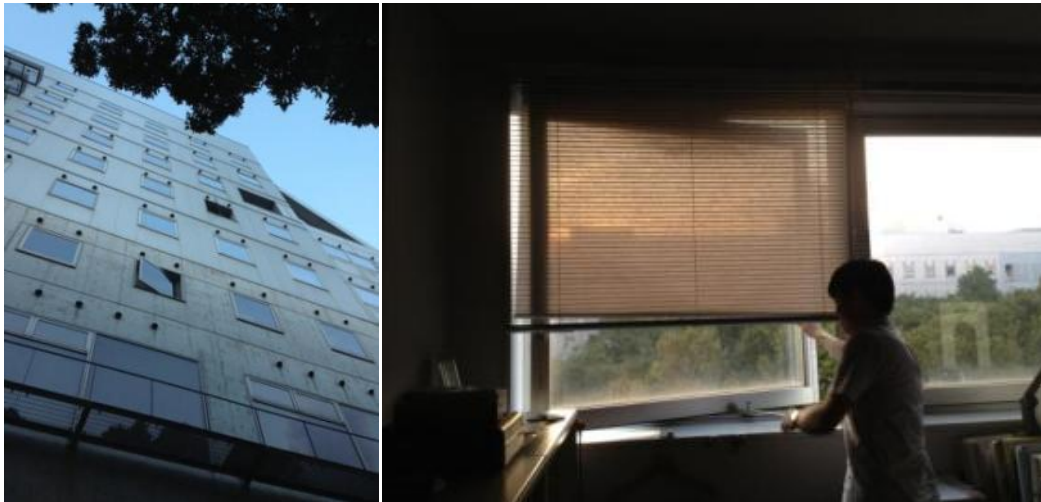

Figure 11. Windows and balcony doors in buildings designed to be run under AC throughout not fitted with sun/ rain protection devices; Operation of the vertically pivoted window interfering with the venetian blind, obstructing simultaneous use of both the controls

Vertical pivoting of windows curtailed wider opening of the window shutter. The shutter could not be turned beyond the window jamb as it interfered with the venetian blinds fitted to the interior wall. Therefore, windows could not be opened fully well. Most of the ventilating corridors were fitted with vertically pivoted windows. These obstructed the user movement in the corridors (Figure 12). In some cases, the bottom hung horizontal high level smoke vents were opened and were used adaptively, in NV mode. However, these could not be used for long during the day, due to occasional rain splashing into the interior.

4.2 Operation and maintenance factors



Figure 12. Opening the ventilating doors into the thoroughfare passage ways directly affected privacy; Vertically pivoted windows in the ventilating corridor obstruct free movement of people.

Most of the work-stations are not provided with personal fans (80 – 86%). Tanabe at al. noted that the plug-in power supply in the year 2011 was seriously restricted in offices due to stringent *setsuden* norms (Tanabe, et al., 2013). In this study we observed floor mounted common fans being used to provide increased air movement at elevated temperatures. About 3 – 6% did not have access to these also. Anecdotal responses revealed that, in the absence of

ceiling fans, air movement distribution throughout the serviced area perhaps could not successfully be achieved with these. Thus, non-availability of additional personal fans was found to be a limitation to achieve thermal comfort in summer. As the ventilating doors in a majority of offices opened in to the main thoroughfare corridors, opening them affected privacy, and perhaps also has caused mild disturbance. This in some cases has limited the door usage.

4.3 Thermal history and behavioural factors

Japanese office occupants are possibly accustomed to much lower indoor temperatures prior to the *setsuden* in 2011. Field studies conducted in Japanese offices in the year 2003 to 2007 provide evidence to this. Goto et al. noted the indoor temperatures in the offices to be in range of 22.5 °C (SD = 0.8 K) in the morning while the peak temperature was around 26.9 (SD = 0.8 K) in summer (Goto, et al., 2007). The indoor temperatures recorded in our study are higher than this.

It appears that the subjects had a thermal history of working in overcooled environments in the previous years, without the necessity of using the environmental controls like fans, windows and doors adaptively. This might have inhibited the occupants from fully exploiting the available environmental controls prior to adaptively switching on the AC systems.

The occupants used the AC systems adaptively in summer. They ran the offices in NV mode for three to four hours in the morning and then switched the AC systems on, when the outdoor temperature was high. However, we noticed some subjects having slight attitudinal non-preparedness in switching back to the NV mode during the day. Yun and Steemers observed similar time-dependent occupant behaviour in UK offices in opening and closing the windows (Yun & Steemers, 2008). Ackerly and Brager found the window signalling systems beneficial if their purpose was well understood and that they were visible to the occupant. It may be beneficial to install such systems to encourage longer spells of operation in NV mode (Ackerly & Brager, 2013). They emphasise on effective communication with the occupant.

5 Concluding remarks

In a field study in four offices in Tokyo in summer 2012 we collected the thermal comfort responses and simultaneous environmental measurements. All the offices attempted to observe the *setsuden* recommendation for indoor temperatures during the survey. The adaptive model is proposed and the comfort temperature in summer is found to be 27.0 and 27.4 °C in NV and AC modes respectively. Window operation improved the indoor conditions. Fan usage increased with temperature. Our logistic regression equation predicted that, about 80% fans would be on when the indoor temperature would around 28 °C. Adaptive operation of environmental controls was hindered by design, operation and maintenance factors, which are not in the direct control of the occupant often times. Occupants' thermal history of cooler temperatures in offices perhaps could have hindered the adaptive use of environmental controls. In the changed scenario of energy concerns, it may be prudent to relook at the design of openings and take advantage of increased air movement even in fully air-conditioned buildings in Japan.

Acknowledgements

The Japan Society for Promotion of Science and The University of Tokyo, Japan funded this research. For data analysis, we used the facilities at the Centre for the Built Environment, University of California Berkeley, made available through the Fulbright Grant. They all are thanked for their financial and logistic support. We acknowledge the participation of all the heads of offices and the subjects for their involvement.

References

Ackerly, K. & Brager, G., 2013. Window signalling systems: control strategies and occupant behaviour. *Building Research & Information*, 41(3), pp. 342-360.

ASHRAE, 2010. *ANSI/ASHRAE Standard 55-2010, Thermal environmental conditions for human occupancy*, Atlanta: s.n.

Brager, G. S., Paliaga, G. & de Dear, R., 2004. Operable Windows, Personal Control. *ASHRAE transaction*, pp. Vol.110, Part 2, pp 17-35.

CEN:15251, 2007. *Indoor environmental input parameters for design and assessment of energy performance of buildings: addressing indoor air quality, thermal environment, lighting and acoustics..* Brussels: Commite European de Normalisation.

CIBSE, (The Chartered Institution of Building Services Engineers, 2006. *Environmental Design Guide, Vol.A*, London: s.n.

de Dear, R. J. & Brager, G. S., 1998. Developing an Adaptive Model of Thermal Comfort and Preference. *ASHRAE Transactions*, 104(1), p. 145–167 .

EIA, E. I. A., 2013. *Country analysis briefs, Japan,, s.l.:* s.n.

Goto, T. et al., 2007. Long-term field survey on thermal adaptation in office buildings in Japan. *Building and Environment*, Volume 42, pp. 3944-54.

Griffiths, I. D., 1990. *Thermal Comfort in Buildings with Passive Solar Features: Field Studies* , s.l.: s.n.

Haldi, F. & Robinson, D., 2008. On the behaviour and adaptation of office occupants. *Building and Environment*, Volume 43, pp. 2163-2177.

Humphreys, M., Rijal, H. & Nicol, J., 2013. Updating the adaptive relation between climate and comfort indoors; new insights and an extended database. *Building and Environment* , Volume 63, pp. 40-45.

Indraganti, M., Ooka, R. & Rijal, H. B., 2013. Field investigation of comfort temperature in Indian office buildings: a case of Chennai and Hyderabad. *Building and Environment*, 65(7), pp. 195-214.

Indraganti, M., Ooka, R. & Rijal, H. B., 2013. Thermal comfort in offices in summer: Findings from a field study under the ‘setsuden’ conditions in Tokyo, Japan. *Building and Environment*, 61(3), pp. 114-132.

Indraganti, M., Ooka, R., Rijal, H. B. & Brager, G. S., 2014. Adaptive model of thermal comfort for offices in hot and humid climates of India. *Building and Environment*, p. 10.1016/j.buildenv.2014.01.002.

Ministry of Economy, Trade, and Industry, Japan, 2011. *Summary of setsuden during summer of 2011*, s.l.: s.n.

Nicol, F. & Humphreys, M., 2007. Maximum temperatures in European office buildings to avoid heat discomfort. *Solar Energy*, Volume 81, pp. 295-304.

- Nicol, F. J., 2001. *Characterising occupant behaviour in buildings: towards a stochastic model of occupant use of windows, lights, blinds, heaters and fans*. Rio, Brazil, Proceedings of the seventh international IBPSA conference.
- Rijal, H. B., Honjo, M., Kobayashi, R. & Nakaya, T., 2013. Investigation of comfort temperature, adaptive model and the window-opening behaviour in Japanese houses. *Architectural Science Review*, 56(1), pp. 54-69.
- Rijal, H. B. et al., 2008. Development of adaptive algorithms for the operation of windows, fans, and doors to predict thermal comfort and energy use in Pakistani buildings. *ASHRAE Transactions*, SL-08(056), pp. 555-573.
- Rijal, H. B. et al., 2007. Using results from field surveys to predict the effect of open windows on thermal comfort and energy use in buildings. *Energy and Buildings*, p. 39 (2007) 823–836 .
- Rijal, H. B. et al., 2008. Development of an adaptive window opening algorithm to predict the thermal comfort, energy use and overheating in buildings. *Journal of Building Performance Simulation*, pp. Vol 1, No1, March 2008, 17-30 .
- Tanabe, S.-i., Iwahashi, Y., Tsushima, S. & Nishihara, N., 2013. Thermal comfort and productivity in offices under mandatory electricity savings after the Great East Japan earthquake. *Architectural Science Review*, 56(1), pp. 4-13.
- Yun, G. Y. & Steemers, K., 2008. Time-dependent occupant behaviour models of window control in summer. *Building and Environment*, 43(9), pp. 1471- 1482.

Adaptive comfort opportunities under mechanically conditioned environment

Alexandre Freire¹, José Luís Alexandre¹ and Fergus Nicol²

1 Faculty of Engineering of the University of Porto, Rua Dr. Roberto Frias, 4200-465 Porto, Portugal, ajfreire@fe.up.pt;

2 Low Energy Architecture Research Unit (LEARN), London Metropolitan University, 40 Holloway Road, London N7 8JL, UK

Abstract

Despite being provided by mechanical ambient conditioning systems or not, all building have to a certain extent a degree of adaptation. Studies have shown that with either a weak or strong dependency to outdoor conditions there always are adaptive opportunities that might have a significant impact on comfort perception. Changes on building design have also affected occupant's expectations and the way they perceive thermal comfort.

Based on the current usage of cooling systems this paper intend to derive how adaptive the systems already are and what possibilities are to heed to a more adaptive pattern.

In this paper are compared spaces conditioned with different cooling systems, from all air HVAC systems to mixed-mode rooms with split units. The adaptability to variable conditions and occupant's expectations are studied as a function of the type building through field studies.

Keywords: adaptive comfort, adaptive opportunities, mixed-mode buildings, HVAC systems, controllers

1. Introduction

During the 20th century thermal comfort became a product supplied by heating, ventilation and air conditioning (HVAC) devices running on cheap energy. With air conditioning, openable windows became superfluous or even counterproductive, and as a result, office building facades turned into a fully sealed protection shield between the inside and the outside environment. The people's attitude towards comfort was influenced dramatically and research focused on defining optimum environments for thermal comfort (Raymond J. Cole et al., 2008). Fanger's indexes of PMV (Predicted Mean Vote) and PPD (Percentage of People Dissatisfied) still is currently used by heating and air-conditioning engineers, to predict for any type of activity and clothing the thermal environments for which the largest possible percentage of a given group of people experience thermal comfort (Van Hoof, 2008). Temperatures were regarded as an ideal constant value for a given set of occupancy. His model remains in the principal standard on thermal comfort like the EN15251(CEN, 2007) and the ASHRAE 55(ASHRAE, 2010).

However, building's reality is forcing to rethink the existent comfort models and indexes, analysing their gaps and suitability to new type of buildings (Cole et al., 2008). The push for energy efficiency on the building sector has led to an increasing diversity of building design and operation of HVAC systems. It's likely nowadays to

find buildings suited with more adaptive opportunities, although provided with conventional HVAC systems. Moreover, trend is to reduce or minimize the use of mechanical cooling for economic reasons. Therefore, building and comfort research is now in need for contextualizing the comfort/energy potential in a climate dependent relationship between occupancy, building and local outdoor environment (Nicol, 2007).

Humphreys work in the 80's already indicated a possible dependency to the outdoor weather based on the results for field studies on buildings with cooling and/or heating systems (Humphreys, 1981). The same trend is clear in more recent studies about an overall large sample of mechanically conditioned buildings (Humphreys et al., 2013). These results have shown that even in a small degree, generally speaking, heated and cooled buildings are also adaptive in some way.

Based on both energy and comfort guidelines and standards, HVAC systems are used in a constant manner. Even the more dynamic kind of systems, like the variable flow and variable speed systems are set up to a constant value of temperature that is considered as the comfort temperature. This value is supposed to remain constant whenever the systems are used. Yet, the building is at the same time interacting with other dynamic features, like heat gains and natural ventilation that result on a drift from the set point temperature. The systems' dead band should control those deviations narrowing the range of temperature allowed in a room. However, there is no reason why the system itself could operate in a more adaptive way. Although it's true that people's perception of comfort varies from naturally to mechanically conditioned buildings, it is also true that there are room for adaptive action in such buildings. Those opportunities could be behavioural, physiological psychological adaptations (Brager and de Dear, 1998). If the adaptive comfort, similar to the naturally conditioned buildings, is accepted by the occupancy then a significant reduction of the energy intensity of buildings could be explored. So it is important to assess how adaptive the different cooled/heated buildings already are and how they can become more adaptive.

Studies have shown that the perceive control by the occupants play a major role in their tolerance and acceptability of their thermal sensation (Deuble and de Dear, 2012a). Among the findings of Deuble and de Dear study it was found that occupants' acceptance of the same combination of thermal conditions was dependent on the building's mode of operation (Deuble and de Dear, 2012b). Detailing the use of some adaptive actions in mixed-mode buildings Rijal et al. concluded that occupants controlled the building to provide substantial seasonal variation in the indoor temperature (Rijal et al., 2009). Also field studies have shown that when available people take an active role adjusting their environment through technical and behavioural measures(Liu et al., 2012).

Although there is an increasing interest in the design of mixed-mode buildings, it comes with additional challenges that need to be considered regarding the use of the adaptive opportunities they bring the rooms. Classical thermal comfort studies are still in need (de Dear et al., 2013). This paper will provide additional evidence, from mechanically cooled buildings, suggesting that there is an interesting potential for adaptive comfort. It will also approach the possibility of these buildings follow similar patterns to the ones specified locally for naturally cooled buildings, in this case the, according to the EN15251.

2. Methodology

In this paper will study five buildings provided with five different mechanical conditioning systems. Traditional office buildings are already equipped with some adaptive opportunities, and these buildings are representatives of the common practice in Portugal. All cases could be considered as mixed-mode buildings as they are able to resort both to natural ventilation and mechanical cooling. The main objective is comparing the comfort and temperature profiles and assess if there is any influence of the conditioning systems and the adaptive features they have.

The field study lasts for about 8 week covering the months of July and half August and September. The two buildings with a controllable central cooling system, P4 and P5, were interviewed for 2 additional weeks during September. During the second half of August buildings were almost empty due summer leave, therefore the comfort campaign was interrupted these weeks. All buildings were interviewed under their usual operating mode. The temperature dead-band was partially controlled by the central systems and by the local thermostats of room or terminal units. Therefore it was expected relaxed dead-bands. With this was tested the thermal acceptability to more variable conditions.

A classical comfort field study was undertaken in every building simultaneously. The polling strategy was based on the repeated transverse approach. All occupants were invited to participate in the study by answering an online comfort survey. The questionnaire was designed to be compact and quick. Therefore it was based on the SCATS's and COMMONCENSE longitudinal survey. People were asked about their thermal feeling, preference and acceptability, their actual clothing and activity. Additionally, the survey included questions about the active controllers and the use of thermostats. Occupants were free to answer the surveys up to twice a day, though the entire population were visited and sampled once a week.

Together with the questionnaires air temperature and relative humidity were measured continuously, using a reading time step of 15min. The indoor air velocity and the mean radiant temperature were measured during a week in every month. For the first one was used a hot sphere anemometer and for the last one a globe thermometer. Outdoor temperature was collected locally using the campus weather station. Running mean temperature was calculated from these records.

3. Description of the case studies

The experimental work took place during the summer season from July till September inclusive. August was also included in the monitoring although responses were scars due to the vocational season. Five case studies were selected and are described below. Over 190 people were interviewed and over 1300 answers were collected. All case studies are considered as air conditioned buildings (AC) for they are mainly controlled through mechanical cooling. However, they have access to both mechanical and natural cooling.

3.1 P1 - FEUP - 2nd floor:

This is the second floor of a 4 storey building (Figure 1). The building is used for the administrative services and is configured for open offices and individual offices. This building follows the conventional constructive characteristics in Portugal, double brick walls, and double glazed fenestration.

The offices are all suited with openable windows, local lighting control and single packaged units cooling systems (conventional split systems), also locally controlled. Some occupants have local fans. For the fresh air, the offices have a mechanical ventilation system providing a minimum rate without any cooling. Besides, occupants are able to increase fresh air rates by opening the windows.

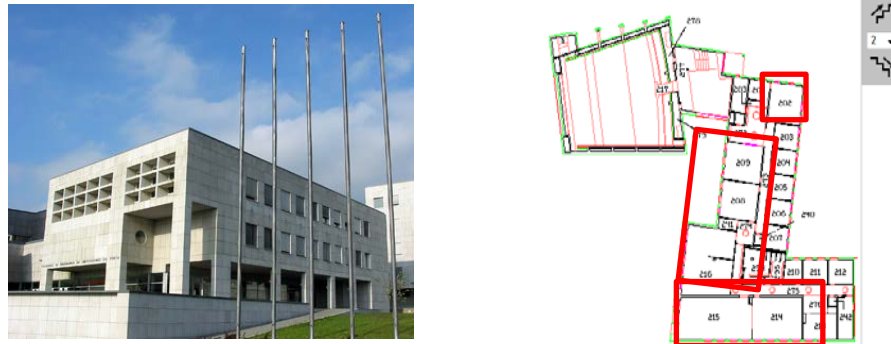

Figure 1. FEUP's administrative second floor and layout

There are no constant patterns regarding the indoor set points and usage frequency as the systems are used as another adaptive opportunity of the space. However, air velocity is roughly constant and below 0.25 m/s.

In this case study 39 participants were pooled, with a range of ages of 20's to 40's, reporting 305 answers. The occupancy schedule begins at 8am until 6pm, with a lunch break from 12am to 2pm.

3.2 P2 - Basement FEUP

This building corresponds to a partially buried floor, highly occupied, dedicated for the administrative services. The basement layout consists in 2 large open offices and 2 individual offices. Windows can be opened, though for security reasons they usually remain closed.



Figure 2. FEUP's basement floor and layout

In this case study 32 participants were pooled, with a range of ages of 20's to 50's, reporting 414 answers. The occupancy schedule begins at 8am until 6pm, with a lunch break from 12am to 2pm.

The case study is suited with an advanced chilled beam system. A central chiller provides cool water to a set of chilled beam panel scattered through the ceiling. An air handling unit (AHU) provides pre-cooled fresh air to the terminal units. There is a single thermostat for each room controlled by the occupants. However the AHU is set automatically by the building management system.

3.3 P3 - Library FEUP

This building is an 8 floors building, with a partially buried floor. The building has a mixed use of conventional office and library. Staffs are located on the basement, ground, fifth and sixth floors and compose the subjects interviewed in this thesis, since it is focused on permanent occupancy. The location of the occupants is identified at Figure 3. All rooms are open office layouts, shared with 3 or more people, with openable window at the 5th and 6th floors.

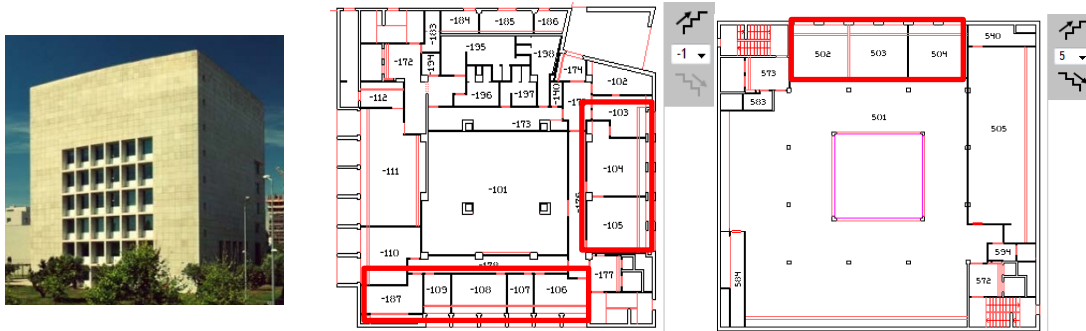

Figure 3. FEUP's library and layout

The building is completely served by a traditional HVAC system. It is cooled by two chillers, 81kW each, which provide cool water to a set of Air Handling Units (AHU) throughout the building, with some units treating only fresh air. The system is controlled by a building management system (BMS) at a central facility of the Faculty.

The control system is limited. The AHU that serve the interviewed rooms are set for an ambient temperature of 23 °C and are always on during the working hours. However AHUs with fresh air only do not have indoor temperature sensor to control the rooms. Thus, units are controlled with estimates of supply air temperature. From the occupant's point of view the available controls are for lighting, fan coils although not very used, and in some cases windows. Ground floor and basement are occupied floors without operable windows, while at the top floors people are able to open their windows.

In this case study 29 participants were pooled, with a range of ages of 20's to 50's, reporting 183 answers.

3.4 P4 - INESC 1

This building is a research facility mainly characterized for open spaces and individual offices. The open plan areas were the subject for this thesis. The building has 4 floors with this configuration, from which floors 1 to 3 were studied. The glazing area is considerably large in the open offices and windows are openable (Figure 4).



Figure 4. INESC façade of old building and layout

The building is equipped with an all air centralized system, consisting on a central production of cool water with thermal storage and air handling units per storey. Additionally it has fan coils located at the periphery of the spaces. Occupants have also installed local fan to increase the air velocity.

In this case study 46 participants were pooled, with ages of 20-30's, reporting 175 answers. The large majority of the occupants were students and young researchers.

3.5 P5 - INESC 2

This building is also a research facility with a similar layout as the previous case study (Figure 5). From this building were collected data from the 4 office floors. Windows are openable by vertical or horizontal axis. At the time of the campaign the building was partially occupied.

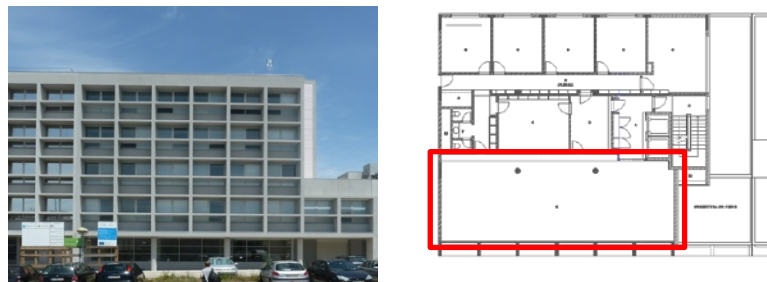

Figure 5. INESC façade of new building and layout

Since it is a newer building the air conditioning system is different from previous case. The centralized system keeps the same configuration. Yet, terminal unit were added at the ceiling level to fine tune temperatures. The thermostat controls all terminal units in the room. Diffusers on the ceiling are alternate between the central AHU and the terminal unit creating a homogeneous distribution of the temperature.

In this case study 32 participants were pooled, with a range of ages of 20's to 30's, reporting 414 answers. The large majority of the occupants were young researchers.

Summarizing the sampling of the comfort surveys Table I indicates per case study the number of participants and answers collected.

Table I - Summary of samples per case study

Building	P1	P2	P3	P4	P5	P6
AC System	Packaged units (Splits)	Pre-cooler AHU + Chilled beams	General AHU + local fan coils	General AHU + local fan coils	General AHU + local fan coils	General AHU + local rooftops
AC Control	Local	Central + Local	Central + Local	Central + Local	Central + Local	Central + Local
Operable Windows	Yes	Yes	No	Yes	Yes	Yes
Participants	39	32	19	10	46	47
Surveyed area (m²/oc)	10,6	6,5	9,7	12,6	13,3	8,9
Observations	305	414	137	46	175	241
Top Mean (°C)	25,7	25,0	24,0	24,4	24,9	25,7
Top SD	1,2	0,9	1,2	1,6	1,2	1,2
Tout Mean (°C)	23,2	23,5	24,6	23,2	22,9	23,2
Tout SD	4,5	3,8	5,7	5,9	3,3	4,5

4. Temperature profiles

4.1 Comparing temperatures to EN 15251

On a first analysis to the thermal behaviour of the case studies the temperature was plotted against time. Records were obtained continuously for the summer season and during the days of the comfort campaign. Figure 6 reports the daily average of the indoor air temperature only during the occupied days and hours. Temperature measurements took place at several locations on each building simultaneously, so the values shown represent the spatial average considering that the profiles were similar.

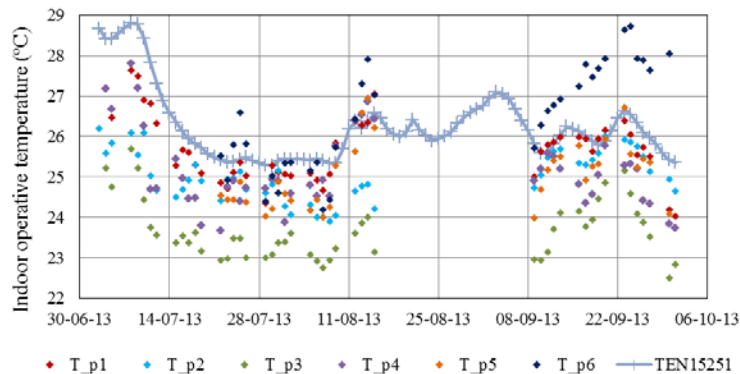

Figure 6. Representative temperature distribution on time for each case study

The EN15251 trend line is included in Figure 6 as function of time. Although it refers to naturally conditioned buildings (NV) it is used as benchmark for the case studies. It is interesting to note how all buildings follow a similar pattern as the one intended for NV. Note that all buildings should be considered as air conditioned buildings (AC), for they are provided with HVAC systems. The type of cooling system is different in every building, and this might affect how they adapt to outdoor. The most sealed building is P3 and it shows the highest offset from EN15251 reference. However, the same building at the upper floors, P4, where windows could be open the metered temperatures were more similar to the other buildings, which also have the same opportunities. The variations and peaks along time are similar in all cases.

That there is an adaptive process to weather is further evident in the Figure 7. In this figure the average indoor temperature during the occupied hours is plotted against the running mean outdoor temperature.

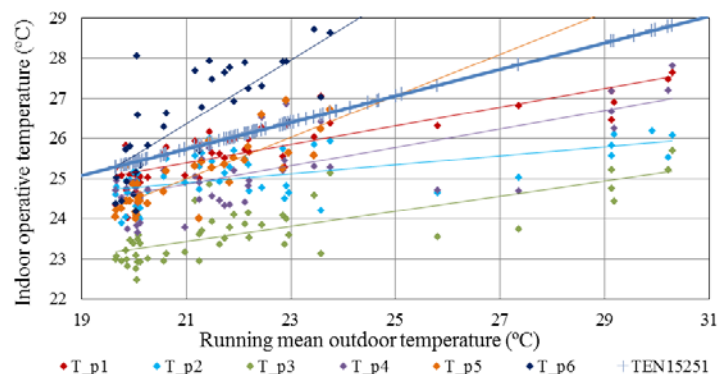

Figure 7. Average temperature dependence to outdoor weather by building

The temperatures above don't mean to report the actual comfort temperatures. Instead, they reveal the normal operating mode of the systems and the usual temperatures they provide. It shows that even AC buildings behaviour is dependent to the outdoor

weather. They don't provide a constant environment detached from the outside. Even case P3, which consist in rooms without any window is clearly a function of weather.

Also, there is a great population of samples above the reference comfort values provided in the national regulations, 25°C in Portugal. It seems that even the mechanical conditioned buildings don't keep lower set point according to PMV.

There is a clear distinction with the cases P5 and P6 that reveal higher temperature slopes. Their trend lines reveal higher slopes than other buildings. Although Figure 7 reports daily average temperatures of a continuous monitoring, it's worth to mention that 80% of the votes are within the comfort zone vote.

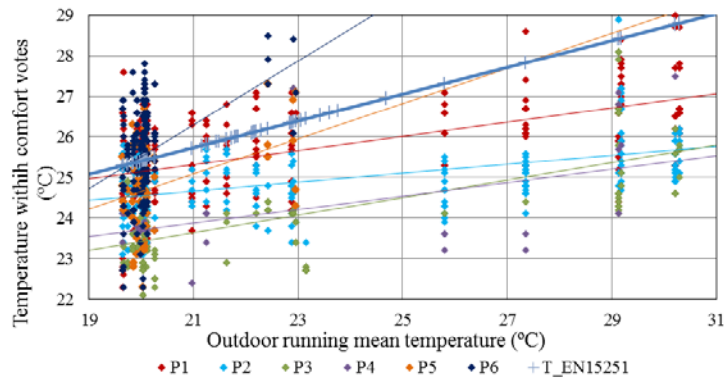
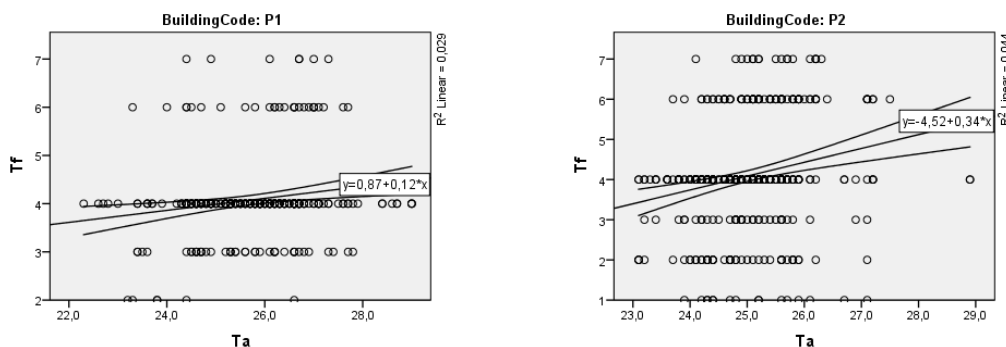

Figure 8. Temperature for comfort zone by system

Figure 8 shows filtered results for the temperature where the participants voted within the comfort zone range. Here are no average values, instead is used the raw data for the votes 3 to 5 on the comfort sensation 7-point scale. It is not conclusive how comfort trend might be affected by the type of cooling system. For instance, cases P5 and P6 could also be regarded as mixed-mode buildings (MM), for they have local control of the HVAC plus operable windows, and this cases show the highest slope on the trend lines. On the other hand, case P1, which is the most similar case to MM buildings (local AC only and windows), has one of the lowest slopes, similar to P3 which is not MM.

4.2 Finding a temperature correlation to outdoors

This section describes the temperature correlation for the comfort votes. For each building was calculated a linear trend line using the full data available. Note that the data contains votes for a wide temperature range despite being AC buildings. Figure 13 reveals that the temperature range varies around 22-28°C.



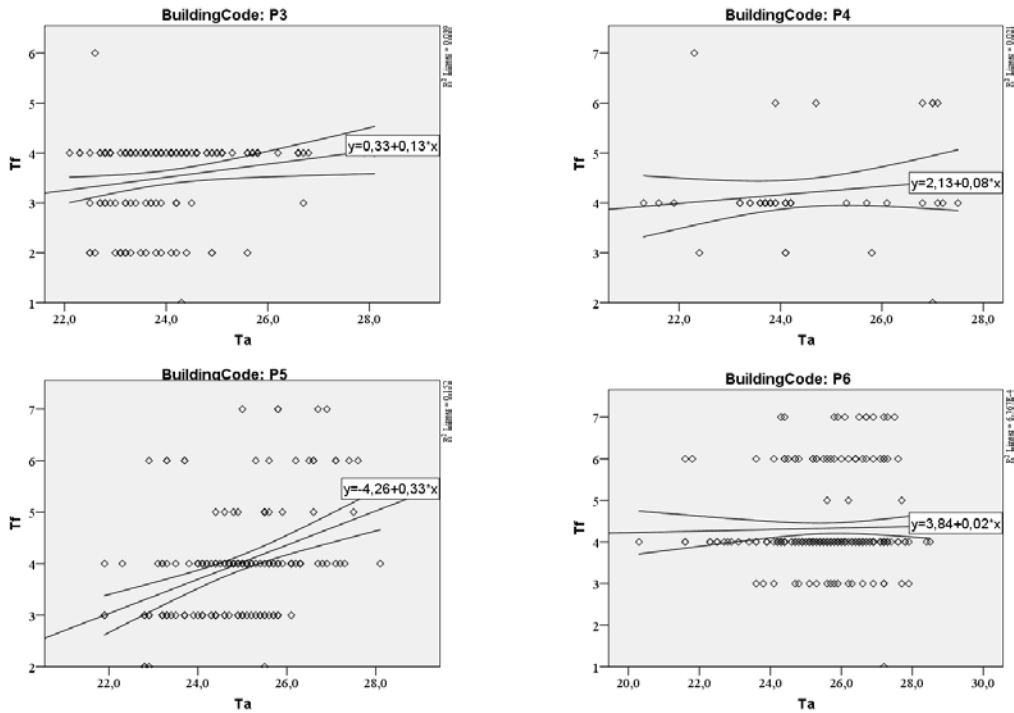

Figure 9. Trend lines for the temperature vs vote correlation. Temperature range is similar for neutral vote in all buildings

The resultant slope coefficients for each case are summarized on Table II. The data collects 50 to 70% of the votes within a comfort scale of 3 to 5. The accuracy of these graphs could be increased by a normalization process using temperatures differences to the daily averages instead of the raw data. However, daily data for these cases was scarce and do not allow accurate results by this mean.

When dealing with observations of longitudinal surveys within a day lap, it is likely to have scarce samples that affect considerably the confidence of the results. Humphreys et al reported that for 10 to 20 observations the standard error is estimated from 0,4K to 0,8K (Humphreys et al., 2013).

The Griffith method is particularly useful for small samples, like the ones on a daily base analysis. This method uses a constant coefficient equivalent to the linear regression slope (Griffiths, 1990). Instead of using values derived from climate chamber, will be used an slope of $0,5K^{-1}$ obtained from field studies. It could be assumed that almost no adaption occurs during a day. Therefore, daily averages of the indoor temperature comfort were used to estimate the comfort temperature.

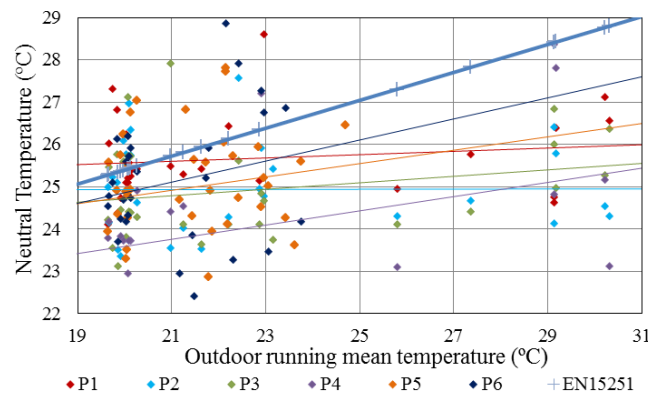

Figure 10. Comparison of neutral temperatures by Griffiths' method

After applying the Griffith method, the daily neutral temperatures were plotted on Figure 9. One of the cases didn't reveal any correlation to the outdoor temperature. In previous figures it was also the case with the lowest slope. Nevertheless, it could be said that there are different comfort patterns than the reported in the standards for mechanically cooled buildings, and that those patterns approach to the NV correlation of the EN15251 in different ways that might be affected by the type of cooling systems they have.

The slopes for each case are compared against the EN15251 in Table VIII.

Table II. Summary comfort results by building

		P1	P2	P3	P4	P5	P6	Average
Average Tn (°C)		25,7	25	24,6	24,2	25,0	25,1	24,9
Griffith	Slope coeff	0,039	0,002	0,076	0,169	0,157	0,248	0,115
	Constant	24,79	24,89	23,20	20,22	21,63	19,90	22,44
Linear Regression	Slope coeff	0,12	0,34	0,13	0,08	0,33	0,02	0,17
	Constant	0,87	-4,52	0,33	2,13	-4,26	3,84	-0,268

The adaptive behaviour in these buildings occurred under their usual behaviour. By concept, a mechanically cooled building should be controlled to retain a constant temperature. Yet, all cases reveal variable temperatures because of the adaptive actions occupants were able to take. Even the more limited case does so. Therefore, there is no reason why a building might not achieve comfort if its central systems are also controlled in an adaptive way.

4.3 Comfort proportions

In this section are compared the comfort zones in all case studies. Using logit lines the seven-point comfort scale the proportions of each vote are highlighted. The lines are obtained using the logit function (1) plotting the proportion as a function of indoor temperature (2). The linear regression keeps the same slope coefficient for every category considering that it cannot be overlaps of comfort categories, i.e., thermal sensation do follow the sequence of the comfort scale. So, one person could not feel comfortable, then too hot and after slightly hot, in a progressive temperature raise.

$$\text{Logit}(p_c) = \log\left(\frac{p_c}{1-p_c}\right) = a + bT \quad (1)$$

$$p_c = \frac{e^{a+bT}}{1 + e^{a+bT}} \quad (2)$$

The probit analyses for each case are reported on Figure 10. Each line gives the proportion of having a vote or less of a give point in the comfort scale. Therefore the comfort zone includes the proportions between voting 5 or less minus voting 3 or less.

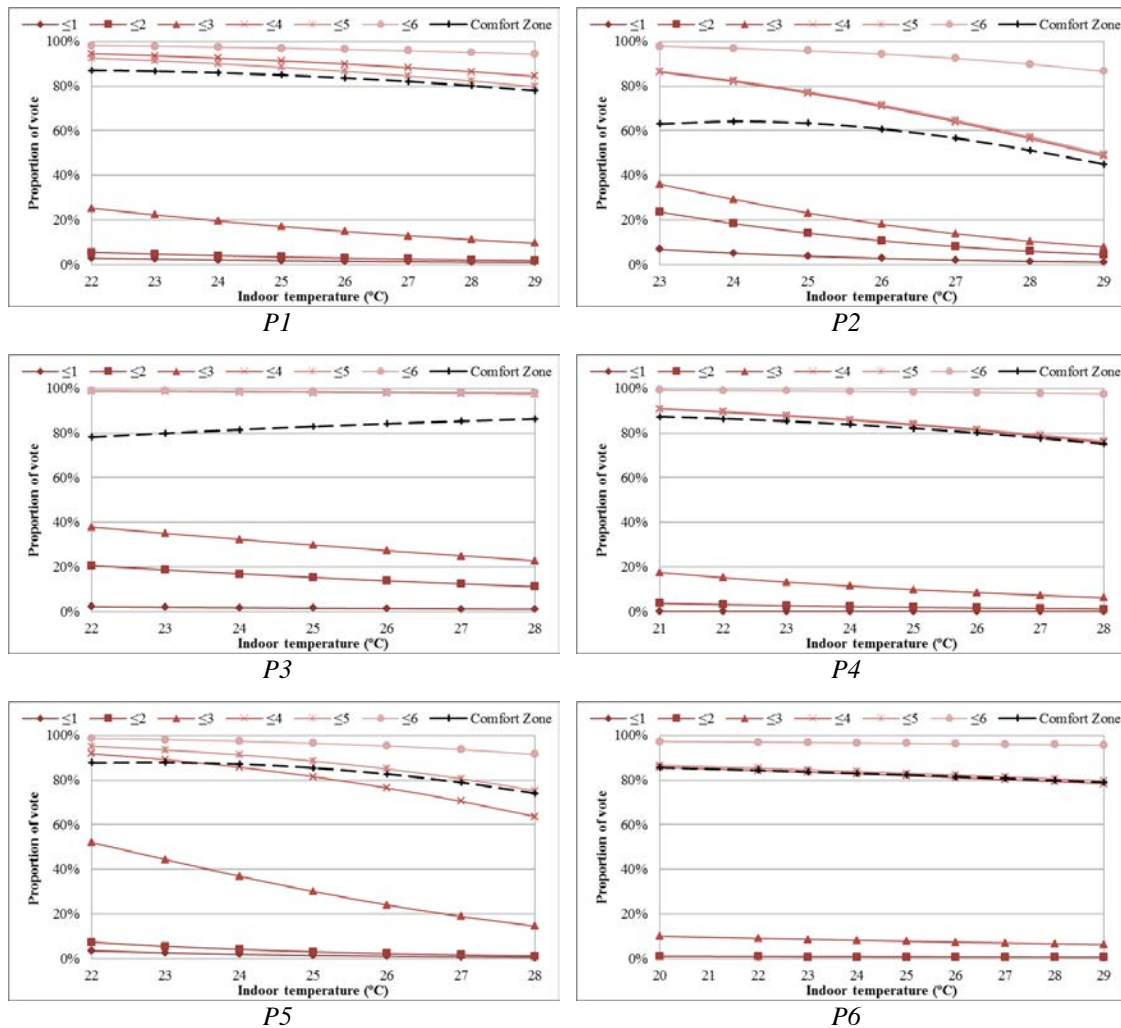

Figure 11. Probit analysis of comfort proportion due temperature per case study

The area until the black dashed line should represent the comfort zone. There is a risk on using an entire block of data from a survey that contains several buildings and long periods (Humphreys et al., 2013). As it is shown on the cases above, the day-to-day variations affect the shape of the bell-curve of the comfort zone. Ideally daily bell curves will reflect accurately the thermal sensitivity of the occupancy.

In this study the overall performance was compared. Hence, a single chart per case was built. Although, the comfort lines are quite flat this could indicate the thermal tolerance within the range “comfortable” and “comfortably warm”. The effect of the adaptive actions over time is embedded in these charts. They suggest that high proportions of about 80% might be achieved through a temperature range from 22 to 29 °C. When asked about how acceptable the thermal environment was for the occupant, in all case studies over 85% of the samples votes as acceptable or very acceptable, and this share keeps roughly constant along the temperature range.

5. Adaptive opportunities

The case studies in this paper could be considered as mixed-mode buildings, as they are able to use the HVAC system as an adaptive opportunity by means of local control and can resort to natural ventilation.

5.1 Frequency

It is not uncommon to see mechanically cooled buildings in Europe that are also suited with operable windows and thus capable of combining the best features (Deuble and de Dear, 2012b). They, in theory, should make use of natural ventilation whenever possible and mechanical cooling as backup.

Table summarizes the frequency of use of the adaptive features available. Percentages are shown relative to the number of observations per building.

Table III. Frequency of use of the adaptive controllers

Building	Samples	Window	Blinds	Lights	Fans	AC
P1	305	30%	34%	61%	7%	57%
P2	414	29%	31%	60%	5%	57%
P3	137	15%	28%	69%	6%	72%
P4	46	22 %	28%	65%	7%	37%
P5	175	30%	29%	75%	7%	65%
P6	241	30%	38%	69%	10%	57%

In average the buildings made use of windows in about 30% of the votes, with except of case P3 that have very few windows available. They overall votes regarding the air conditioning represent 60% of the samples. Also, local control for lighting and blinds was always available and the participants reported almost 70% and 35% of usage respectively. This further supports that even AC buildings make reasonable use of other adaptive opportunities.

Following the same trend as reported by Rijal et al, in their study on mixed mode buildings (Rijal et al., 2009), the availability of AC control as adaptive opportunities reduces the use of natural ventilation considerably. Interesting to note that is their study they included buildings as AC with operable windows, and some of those cases had similar probabilities as MM buildings. The same is verified here, a total AC case as P3, with very few windows, reveals the same pattern of use of the MM buildings.

5.2 Combined use of AC

When available multiple actions may take place at the same time. Although there are other reasons than thermal comfort for using the available controllers, results, show that when AC is on, people kept their windows closed during about 90% of the time. Still some cases reached 15% of open windows. In these cases windows could have left open due dissatisfaction with the AC, or for air quality reasons.

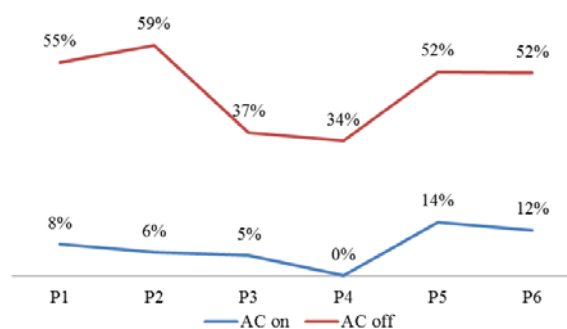

Figure 12. Percentage of open windows according to the AC condition

Figure 11 shows how occupants make use of both controllers as a changeover mixed-mode building. Windows are likely to be open when AC is off and when they are close indoor temperatures is also in free floating. Considering that the AC is on about 60% of the time, from which about 50% windows are open simultaneously, then the frequency when there are no active controllers is quite reduced, about 15 to 20% of the observations.

The use of fans is very low because in Portugal it is not usual buildings been design with local fans. The cases reporting its use refer to local fans placed by the occupants. Nevertheless, this feature was always used together with the air conditioning system. This might suggest that local ventilation to increase convective body heat losses could be a useful supplement to active controllers in mechanically cooled buildings.

Lighting and blinds are other mean of reducing heat gains in the buildings. On average, 65% of the votes when AC was on lightings were also on. Blinds as well were used about 35% of the times together with AC.

5.3 Use of mechanical cooling thermostat

All cases were suited with some degree of local control. Some had one thermostat per room. Others had control over their local fan coil units spread in every room. Comparing all cases it was found a common issue. Almost 10% of the responses claimed that there was no control of their mechanical cooling. Also, another 5 to 8% reported people using their thermostats while replying it was off.

This misinformation about their cooling systems might affect the effective use of their controllers. It is not rare finding occupants that do not know when their systems are running, under normal circumstances, and how to operate with their AC systems so they can perceive the effectiveness of their actions.

This goes in line with the feedback collected from the question “Have you adjusted you thermostat recently?” On average, from 80 to 90% of the answers said they didn’t. This information was verified from interviews in each building, where the common response was that they don’t usually use the thermostat.

5.4 Thermal perception and controllers

This section describes the usage of controllers relative to their thermal sensation and preference. The usage proportion of each controlled was calculated according to binned scales of the thermal sensation and preference. The new scale for the thermal feeling is shown on Table IV, and for the thermal preference on Table V. Additionally, the proportions consider the distributions of the sample on the comfort scale. A weighted average by point-scale was multiplied to the proportion as shown in the equation 3.

$$p = \frac{C_i}{\sum_{i=-1}^1 ci} \cdot \frac{n_i}{\sum_{i=-1}^1 n_i} \quad (3)$$

Here p is the proportion of having a controller C active at a given thermal sensation or preference. The number of observations per each point-scale of comfort is n, and “i” represents the points on the respective proportion scales shown below.

Table IV. Scale conversion for thermal sensation

Bedford Scale	Proportion Scale
1.Much too cool	-1.Uncomfortable
2.Too cool	
3. Comfortably cool	0. Comfortable
4. Comfortable	
5.Comfortably warm	
6.Too warm	1.Uncomfortable
7.Much too warm	

Table V. Scale conversion for thermal preference

Thermal Preference Scale	Proportion Scale
1.Much warmer	1. Warmer
2. A bit warmer	
3.No change	0. No change
4. A bit cooler	-1. Cooler
5. Much cooler	

The proportions for each controller available as function of the thermal feel and preference respectively on table and table.

Table VI.Use of controllers by thermal feeling

Building	Tf	Votes	Windows	Blinds	Light	Fan	AC
P1	-1	6	0,00	0,00	0,00	0,00	0,00
	0	265	0,79	0,78	0,77	0,67	0,75
	1	34	0,01	0,01	0,01	0,03	0,01
P2	-1	60	0,01	0,02	0,03	0,05	0,03
	0	257	0,45	0,40	0,37	0,40	0,36
	1	97	0,05	0,05	0,05	0,01	0,06
P3	-1	23	0,04	0,02	0,02	0,00	0,02
	0	113	0,62	0,72	0,74	0,82	0,71
	1	1	0,00	0,00	0,00	0,00	0,00
P4	-1	1	0,00	0,00	0,00	0,00	0,00
	0	38	0,74	0,41	0,66	0,83	0,58
	1	7	0,00	0,08	0,03	0,00	0,04
P5	-1	4	0,00	0,00	0,00	0,00	0,00
	0	151	0,73	0,76	0,75	0,73	0,76
	1	20	0,02	0,01	0,01	0,00	0,01
P6	-1	1	0,00	0,00	0,00	0,00	0,00
	0	197	0,72	0,73	0,68	0,78	0,66
	1	43	0,02	0,02	0,03	0,01	0,03

Being the proportions weighted with the frequency of the thermal sensation provides a sense of the most frequent set of thermal votes and use of the controller. It combines the effect of frequency of the comfort vote with the distribution of the controller status among the comfort scale.

Table VII. Use of controllers by thermal preference

Building	Tp	Votes	Windows	Blinds	Light	Fans	AC
P1	1	81	0,07	0,07	0,06	0,12	0,07
	0	198	0,43	0,41	0,43	0,27	0,44
	-1	26	0,01	0,01	0,01	0,01	0,01
P2	1	168	0,14	0,13	0,16	0,04	0,16
	0	165	0,22	0,17	0,14	0,18	0,15
	-1	81	0,02	0,05	0,05	0,09	0,04
P3	1	16	0,00	0,01	0,02	0,00	0,02
	0	80	0,44	0,28	0,34	0,44	0,34
	-1	41	0,07	0,12	0,09	0,07	0,08
P4	1	21	0,05	0,21	0,23	0,00	0,24
	0	22	0,38	0,22	0,21	0,48	0,23
	-1	3	0,01	0,01	0,00	0,00	0,00
P5	1	53	0,08	0,08	0,09	0,07	0,10
	0	99	0,34	0,35	0,32	0,35	0,33
	-1	23	0,02	0,01	0,02	0,02	0,01
P6	1	100	0,18	0,13	0,16	0,08	0,19
	0	130	0,29	0,34	0,31	0,37	0,26
	-1	11	0,00	0,00	0,00	0,01	0,00

Figure 12 compares the cases of window opening and cooling use splitting the effects of sample size and distribution. It corresponds to the thermal comfort zone in the new scales. Results show good correlation between AC usage and windows opening. People make use of both windows and AC together reducing the energy use. The dashed lines reflect how the comfort zone is wider relatively to the discomfort zone. There might be several reasons besides comfort for why a controller might remain active. Nevertheless, when the shares withdraw from midpoint it could imply that the controller is used more frequently, being while comfort is perceived and changing over when the perception does too. Comparing the windows with AC usage, one could confirm that windows are the first ones upon which occupants will take action, while the AC will take longer even collecting some discomfort votes. Further studies are needed with more case studies to correlate priorities of adaptive actions on AC, windows and others.

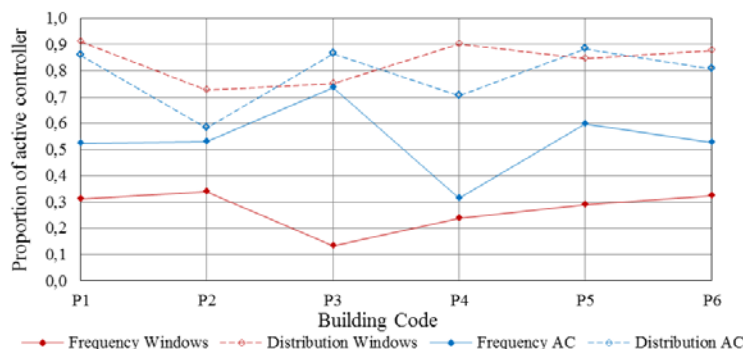

Figure 13. Effect of the number of votes per preference and votes of controllers per scale

Considering the share of active AC by thermal preference in all case studies were detected proportion from 0,6 to 0,8 of AC on while the thermal preference was “warmer”. One of the problems is the limitation of central control for adjusting to different desired temperatures. There is no feedback process that allows changing the

status of the cooling system and therefore it might generate undercooling issues. This effect is further seen in the weighted proportions of Table VII. Discomfort is generally reported more for undercooling than for overheating.

6. Conclusions

Given the need for evidence on the behavior of AC buildings, this paper showed a contribution of 6 more samples where an adaptive behavior was evident. Some point resultant from the analyses presented in this paper could be drawn.

The cases used in this paper showed that it's possible that AC buildings operate under adaptive patterns. Results showed that the indoor temperature of buildings provided with AC could float similarly to the standard pattern of naturally ventilated buildings.

These buildings represent current trend on building/system design, as they were all built in the last 10 years. There is a wide variation of possible systems nowadays. However, is safe to say that almost all new buildings are able to use to sort of natural ventilation. The above increases the grey area on the definition of MM buildings and blurs the boundaries of the comfort metrics.

It was observed that even if buildings are mechanically cooled, controlled for a constant environment, the indoor temperature is quite dependent of weather conditions. Therefore, there is no reason why a building might not achieve comfort if its central systems are also intentionally controlled in an adaptive way.

The indoor-outdoor temperature relation in some cases showed that linear coefficient could be in some cases steeper than NV buildings. Tolerance might be increased because more actions are available for the occupants.

The analysis of the comfort scale proportions showed a very flat comfort area that could be the result of the adaptive process happening along the time scale of the data. However, this needs verified consistency with similar daily based studies. Nevertheless, the study showed there is an interesting potential for adaptive comfort in AC building, where system could adapt to their local indoor/outdoor correlation. Further studies are needed to test this assumption in different locations.

The analysis of the controllers showed that air conditioning is used as an adaptive opportunity, in combination with window opening. However, the misuse of the local control for the cooling systems reveals lack of information on how occupant should operate with their facilities. This factor could significantly reduce the efficacy perceived of the AC as an adaptive action.

Local fans when available were used roughly independently from the AC. This could indicate that on a summer scenario people might accept a trade-off between temperature and air movement if both controls are available locally.

This paper gives a preview of the potential of conventional AC buildings for becoming more adaptive. Further studies will be held contrasting the possibilities of constant against variable temperature profile in the same buildings.

7. References

- ASHRAE 2010. ASHRAE 55 - Thermal Environmental Conditions for Human Occupancy. Atlanta, USA: ASHRAE.
- BRAGER, G. S. & DE DEAR, R. J. 1998. Thermal adaptation in the built environment: a literature review. *Energy and Buildings*, 27, 83-96.
- CEN, E. C. F. S. 2007. Indoor environmental input parameters for design and assessment of energy performance of buildings addressing indoor air quality, thermal environment, lighting and acoustics. Brussels: CEN.
- COLE, R. J., ROBINSON, J., BROWN, Z. & O'SHEA, M. 2008. Re-contextualizing the notion of comfort. *Building Research & Information*, 36, 323-336.
- DE DEAR, R. J., AKIMOTO, T., ARENS, E. A., BRAGER, G., CANDIDO, C., CHEONG, K. W. D., LI, B., NISHIHARA, N., SEKHAR, S. C., TANABE, S., TOFTUM, J., ZHANG, H. & ZHU, Y. 2013. Progress in thermal comfort research over the last twenty years. *Indoor Air*, n/a-n/a.
- DEUBLE, M. P. & DE DEAR, R. J. 2012a. Green occupants for green buildings: The missing link? *Building and Environment*, 56, 21-27.
- DEUBLE, M. P. & DE DEAR, R. J. 2012b. Mixed-mode buildings: A double standard in occupants' comfort expectations. *Building and Environment*, 54, 53-60.
- GRIFFITHS, I. 1990. Thermal comfort studies in buildings with passive solar features. *Field Studies: Report to the commission of the European Community*. UK.
- HUMPHREYS, M. 1981. The dependence of comfortable temperature upon indoor and outdoor climate. *Bioengineering, thermal physiology and comfort*, p. 229e50.
- HUMPHREYS, M. A., RIJAL, H. B. & NICOL, J. F. 2013. Updating the adaptive relation between climate and comfort indoors; new insights and an extended database. *Building and Environment*, 63, 40-55.
- LIU, J., YAO, R., WANG, J. & LI, B. 2012. Occupants' behavioural adaptation in workplaces with non-central heating and cooling systems. *Applied Thermal Engineering*, 35, 40-54.
- NICOL, F. 2007. Comfort and energy use in buildings—Getting them right. *Energy and Buildings*, 39, 737-739.
- RAYMOND J. COLE, RICHARD LORCH, GAIL S. BRAGER & RICHARD J. DE DEAR 2008. Historical and cultural Influences on Comfort Expectations. In: LORCH, R. J. C. A. R. (ed.) *Buildings, Culture and Environment: Informing Local and Global Practices*. Oxford, UK: Blackwell Publishing.
- RIJAL, H. B., HUMPHREYS, M. A. & NICOL, J. F. 2009. Understanding occupant behaviour: the use of controls in mixed-mode office buildings. *Building Research and Information*, 37, 381-396.
- VAN HOOFF, J. 2008. Forty years of Fanger's model of thermal comfort: comfort for all? *Indoor Air*, 18, 182-201.

Occupants' behaviour in office building: stochastic models for window opening.

V. Fabi¹, V. Maggiora¹, SP. Corgnati¹ and Rune Andersen²

¹ TEBE Research Group, Department of Energetics, Politecnico di Torino, Corso Duca degli Abruzzi 24, 10129 Torino, Italy

² ICIEE, Department of Civil Engineering, Technical University of Denmark, Nils Koppels Allé Building 402, 2800 Kgs. Lyngby, Denmark)

Abstract

The interactions between building occupants and control systems have a high influence on energy consumption and on internal environmental quality. In the perspective of a future of “nearly-zero” energy buildings, it is crucial to analyse the energy-related interactions deeply to predict a realistic energy use during the design stage. Since the reaction to thermal, acoustic or visual stimulus is not the same for every human being, monitoring the behaviour inside buildings is an essential step to assert differences in energy consumption related to different interactions. Based on measurements in eight offices in Prague, seven models concerning occupants' window opening behaviour in office buildings were proposed. The dataset was gathered through a monitoring campaign lasting 11 months, from February 2012 until January 2013. Indoor and outdoor environmental conditions were collected in eight south-west exposed rooms, mechanically ventilated and heated through radiators. Two rooms were used by two people while the other six were single offices. Seven models for opening and closing windows were inferred using multiple logistic regression.

The model's outputs were probabilities of a window opening and window closing event within the next five minutes. Implementing all the models into dynamic energy simulation software would lead to different simulated behaviour patterns and consequently different demands and uses of energy, representing a more reliable variability of energy consumption due to building occupants'.

Keywords: Occupant's behaviour; window opening; stochastic modelling

1 INTRODUCTION

Probabilistic models of occupants' behaviour require an important step: observing the real interaction between dwellers and building; several existing models are based on empirical data (Nicol et al. 2007, Mahdavi and Pröglhöf 2009, Bourgeois and Reinhart 2004) although these only include thermal stimuli. This step is the starting point of a path that leads to a better understanding of the links between building, energy consumption and users passing through the study of human behaviour in relation to environmental stimuli.

Pioneering investigations (Dick and Thomas, 1951; Brundrett, 1979; Warren and Perkins, 1984) mostly aimed to find a correlation between the use of the window and the external temperature. Logically if the perceived temperature is increasing then the opening action is more likely to happen. However, temperature is not the only physical environmental parameter influencing occupants' window opening behaviour. Brundrett (1979) and Warren and Perkins (1984) were among the first to demonstrate that also external radiation and wind speed could be considered as predictors of an opening/closing action and (Schweiker, 2010) later noted that “Occupants' behaviour is not only related to thermal, visual and acoustic

stimuli but is a complex system that involve also physiological, psychological and social aspects". The relation between these factors is soft and does not always lead to a certain action. The variation in occupants' behaviour can lead to differences in consumption. As a consequence, measurements of internal and external physical conditions and surveys are essential to understand factors influencing an interaction between the occupant and the building. In this paper we have investigated the effects of certain Volatile Organic Compounds (VOCs) on occupants' window opening behaviour. Some VOCs have certain scents and according to Jones (1999) VOCs have been associated with irritation of the mucus membrane. As such, VOC may be a better predictor of the air quality associated drivers for window opening behaviour.

Many papers have used different mathematical method to infer the probability of an action occurring in order to define behavioural models for opening and closing of windows (Fritch, 1990; Nicol, 2001; Haldi and Robinson, 2008; Herkel et al, 2008; Yun and Steemers, 2010; Schweiker, 2012; Andersen et al, 2013).

This paper describes occupants' behaviour models related to the window opening and closing in offices based on measurements. The statistical analysis was applied separately for each office room in order to take advantage of the variety of monitored data (different in each room) and evaluate which of them could be related to the actions on windows.

2. MEASUREMENTS

Measurements were taken in eight different offices of the Department of Micro-environmental and Building Services Engineering, located in the second floor of a sixteen-storey building. The environmental data collection was part of the EU FP7 project ClearUp and started on February 2012 and ended on January 2013. Figure 1 shows a picture and floor plan layout with indication of rooms. All the rooms are south-west exposed and seven of them have an area of 15 m² (3m x 5m) while room R8, has an area of 30 m² (6m x 5m). The rooms R3 and R6 were shared by two people, while the others are single offices.



Figure 1. Czech Technical University in Prague building (left) and the second floor plan (right).

The offices were heated by radiators placed below a book case; users had the possibility to change the heating set-point through valve actuators and within pre-set boundaries. The

ventilation was controlled by an air handling unit (AHU) placed on the same floor with a pre-set flow rate of 30 m³/h. Users could interact with the ventilation system in pre-set mode according to flow rate values (20,35,50 m³/h). Mechanical ventilation and set-point temperature schedule were constantly active but subordinated to the manual control. For each office natural ventilation was enabled by one of two windows characterised by a rotating frame around a central pivot. The inner roller blinds were both manual and automatic; if the window was open only manual mode was possible. According to the season, the system worked following an algorithm that gave a different position of the blinds for collecting or rejecting solar gains. Users' interaction was always possible but after one hour, the automatic mode resumed. The following variables were measured at 5 minute intervals in all 8 offices:

• *Indoor environment parameters*

- Temperature [°C]
- Set-point temperature [°C]
- Relative humidity [%]
- CO₂ concentration [ppm]
- VOC concentration [ppm]
- Illuminance (in the middle of the room, on desk, at window)

• *Outdoor environment parameters*

- Air temperature [°C]
- Relative humidity [%]
- CO₂ concentration [ppm]
- VOC concentration [ppm]
- Wind speed [m/s]
- Rain (yes, no)
- Wind speed [m/s]

• *Window state (open/closed)*

• *Door position (open/closed)*

• *Contextual Factors*

- Moment of the day (morning, day, afternoon, evening, night)
- Season (winter, spring, summer, autumn)
- Presence measured by PIR sensor (arrival the first 15 min, intermediate, departure the last 15 min.)

3. STATISTICAL ANALYSIS

The probability of an opening and closing event was inferred using multivariate logistic regression with interactions between selected variables (equation 1). The statistical software R was used for all data analysis and modelling.

$$\text{Log} \frac{p}{1-p} = \beta_0 + \beta_1 x_1 + \beta_2 x_2 + \dots + \beta_k x_k + c_{12} x_1 x_2 + c_{13} x_1 x_3 + \dots \quad (1)$$

Where:

p is the probability of an switching on/off event

β_0 is the intercept

β_{1-n} are coefficients

x_{1-n} are explanatory variables such as indoor room temperature, relative humidity, ...

c_{12_nm} are interactions coefficients

To reduce the complexity of the model, only interactions terms between environmental and contextual factors (moment of the day, weekdays, seasons) were considered. Through the statistical software R, the Akaike information criterion (AIC) was used individually for each room database to select the predictive variables among the ones monitored during the campaign. This criterion tests one by one the variables in order to find the combination with the lower AIC value (forward and backward selection). In considering the AIC of room R8, an infinite value was found and it was not possible to apply the regression. In the interpretation of the coefficients, the sign, the size and the scale of the corresponding variable have to be taken into account. The scales of the variables should be taken into account: Schweiker and Shukuya (2009) suggested to multiply the scale of the variable with the coefficient, to get an indication of the magnitude of the impact from each variable.

4. RESULTS

Since temperature is generally correlated to seasons and time of day, the whole day was divided into different periods. Since it was demonstrated (Warren et al. 1984) that occupants' window actions occur mostly when occupants arrive or leave the workplace, and windows are mainly closed at the end of the working day. For rooms with presence detector was possible to split up the presence time into arrival, the first 15 minutes, and departure, the last 15 minutes. From the analysis of each room, the relation between the arrival and the open act appears clearly.

A comparison between the hours of presence and the actions on the window gave the number of opening actions (relative frequency) per day for each room; the mean value of the relative frequency was considered as a threshold to define passive users (number of opening per day lower than the threshold) and active users. These numbers were compared to their mean value equal to 0.15 ACH (Figure 2).

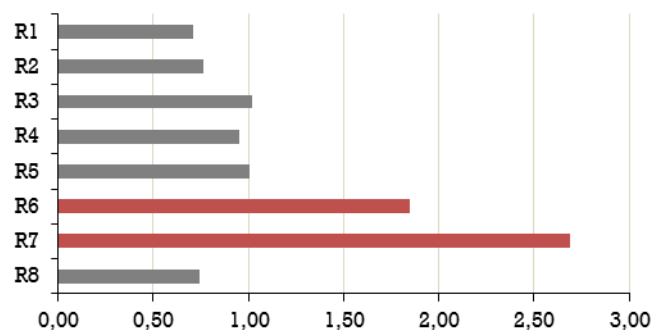

Figure 2. Relative frequency of the opening acts in each room and the determination of active (red) and passive (grey) users

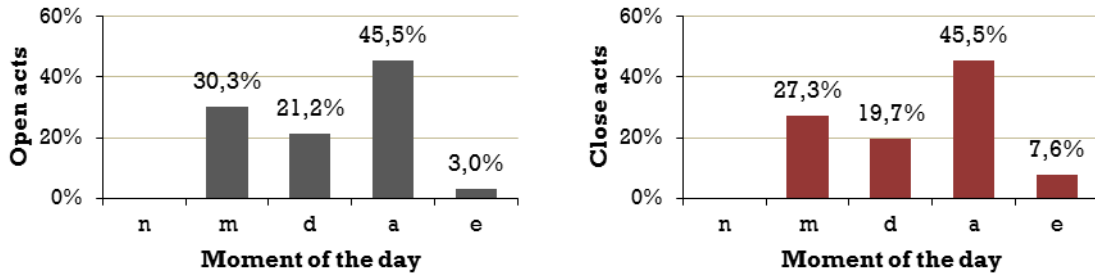

Figure 3. Distribution of opening and closing acts spread throughout the moment of the day [n=night (from 23 to 5 a.m.); m=morning (from 6 to 8 a.m.); d=day (form 9 to 12 a.m.); a=afternoon (from 13 to 17); e=evening (from 18 to 22)] for room R1

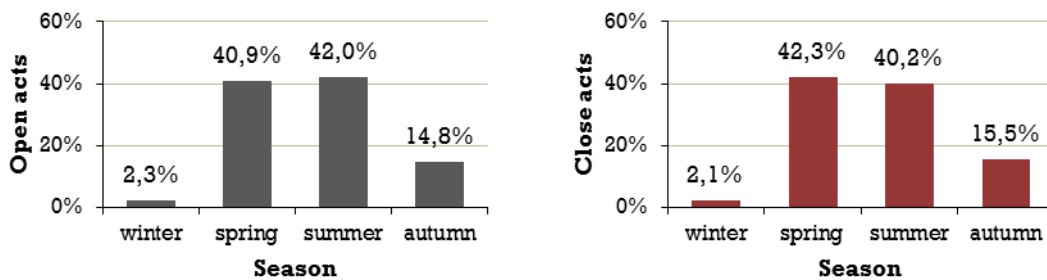

Figure 4. Distribution of opening and closing acts spread throughout the season for room R3.

The main influencing factors for the seven different models were presented in table 1 and in table 2 with their magnitudes. Table 1 is aimed at highlighting the parameters obtained by applying the Akaike information criterion and resulted to be influencing on the actions of opening and closing the windows within all the factors investigated in the case studies. In Table 2 is shown the magnitude of each influencing factor gained by multiplying the regression coefficient for the difference between the maximum and minimum value of the measured parameter.

Table 1. Influencing factors for window opening/closing behaviour for the investigated offices.

Investigated variables	Open windows							Close windows						
	R1	R2	R3	R4	R5	R6	R7	R1	R2	R3	R4	R5	R6	R7
Time of day	X	X					X	X						X
Season	X				X			X					X	
Arrival/intermediate/Departure		X			X	X	X							X
Indoor Temperature		X		X										X
Outdoor Temperature	X							X			X	X	X	X
Indoor Relative humidity			X		X	X								
Outdoor Relative humidity														
Indoor CO ₂ Concentration	X		X		X					X				
Outdoor CO ₂ Concentration											X			X

<i>Indoor VOC Concentration</i>	X	X
<i>Outdoor VOC Concentration</i>		
<i>Door position</i>	X	X
<i>Illuminance in the room</i>		
<i>Illuminance on desk</i>		
<i>Illuminance at window</i>	X	X
<i>Rain</i>		
<i>Wind speed</i>		

Table 2. Magnitudes of resulting influencing factors for energy-related behaviour with respect to window opening/closing for the investigated offices.

<i>Investigated variables</i>	<i>Open windows</i>							<i>Close windows</i>							
	<i>R1</i>	<i>R2</i>	<i>R3</i>	<i>R4</i>	<i>R5</i>	<i>R6</i>	<i>R7</i>	<i>R1</i>	<i>R2</i>	<i>R3</i>	<i>R4</i>	<i>R5</i>	<i>R6</i>	<i>R7</i>	
<i>Indoor Temperature</i> [°C]	12.3		3.57									3.4			
<i>Outdoor Temperature</i> [°C]	3.9									9.6		3.8	6.7	2.8	5.33
<i>Indoor Relative humidity</i> [%]			4.4		4.8	2.1									
<i>Indoor CO₂ Concentration</i> [ppm]	0.001	0.7		0.001									0.6		
<i>Outdoor CO₂ Concentration</i> [ppm]										0.5		0.8			
<i>Indoor VOC Concentration</i> [ppm]								1,07		0.0004					
<i>Illuminance in the room</i> [lux]															
<i>Illuminance on desk</i> [lux]															
<i>Illuminance at window</i> [lux]			1.4									0.5			

The different rooms had different predictors for opening and closing actions (Table 1). Three of the seven behaviour models for window opening were influenced by the indoor relative humidity. This variable had the highest magnitude value in the single room model. The CO₂ was found to be a common predictor for three rooms, but its weight in the models was lower than the other influencing factors. The arrival/departure division was related to the opening actions as a single influence in rooms R2 (figure 5) and R6, but it also interacted with the relative humidity in room R5 and in R7 with the VOC. Furthermore, the moment of the day was more relevant than the season because it was an influencing factor for rooms R1 and R2, and also in the R7 with an interaction with the VOC.

Season also resulted having an impact on the occupants' window opening behaviour in two of the seven analysed room, both for the probability of opening and closing the windows. Since also outdoor temperature affected the window opening behaviour, the seasonal effect is linked to the change of the temperature itself.

In the closing models, a more general influence of outdoor temperature was found in five of the seven rooms, while for the other variables the paths are split. No generalized pattern was found for the contextual factors. . The presence and moment of the day had an influence on the closing probability in room R7 as an interaction with the outdoor temperature (figure 6), and in room R2. In the other analysed rooms both the presence and the moment of the day has not been recongnized as influencing factors for opening or closing windows probabilities. In the following figures two main examples of resulting probabilities as function of indoor temperatures (figure 5) and outdoor temperature (figure 6) are represented.

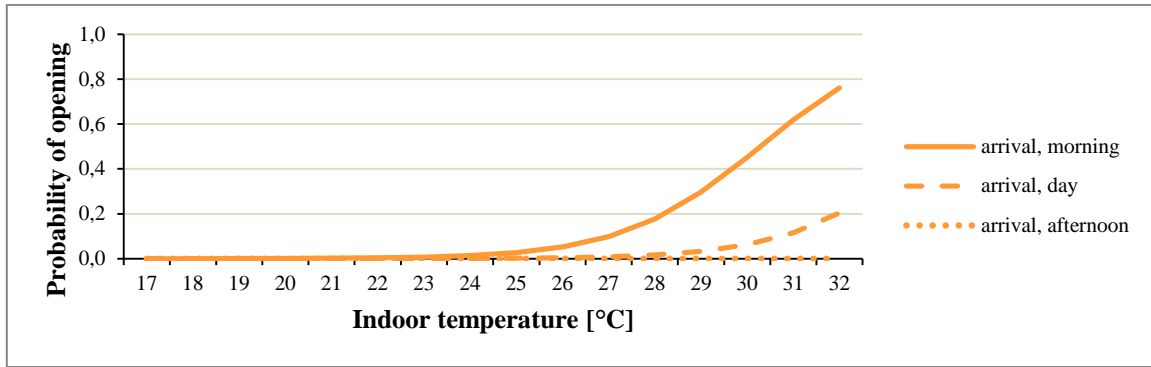

Figure 5. Probability of opening windows for different times of day and indoor temperature for one analysed office behavioural model (R2).

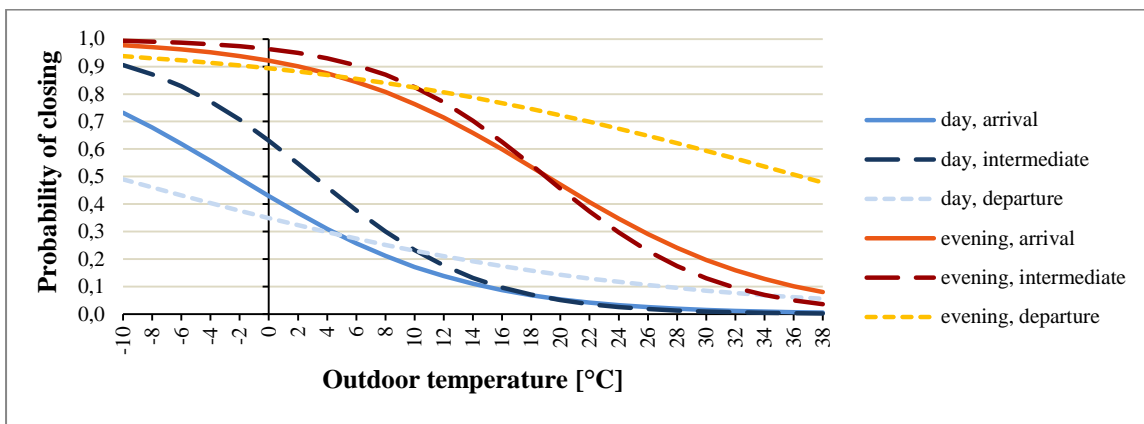

Figure 6. Probability of closing windows for different times of day and office occupancy patterns as a function of the outdoor temperature for one analysed office behavioural model (R7).

5. DISCUSSION

We inferred the probability of opening or closing a window (change from one state to the other) rather than the probability of an open window (state). This approach has its root in a study by Herkel et al. (2005) about the opening actions on a window in office buildings. They used separated probabilistic sub-models for opening and closing at arrival, departure and intermediate presence considering outdoor temperature as a predictor. The relation between a window interaction and the outside temperature was investigated by Rijal et al. (2007), Nicol and Humphreys (2004), Warren et al. (1984) and Fritsch et al. (1990) who all found a positive correlation between open windows and temperature.

Fabi et al. (2012) found that internal variables (such as indoor temperature) may influence occupants' window opening behaviour and should be included in models of occupants' window opening behaviour. Indoor environmental conditions are a consequence of the window state, thus interference may occur between predictors that are internal variables (e.g. internal temperature) and the state of the window that is trying to predict. Furthermore the driving forces that can lead to open a window may be different from to one for closing it.

To implement the results of the statistical analysis in a building energy simulation software, it is necessary to obtain a generalized occupant behaviour model. This work was developed starting from a database that provided many variables both indoor and outdoor to improve the

knowledge about the factors influencing the occupants to perform an action. The first step was to find if variables which are generally not taken into account in behavioural research, like concentration of VOC, could have an impact on the opening and closing behaviour in offices. Since some variables were only monitored in some rooms, it was not possible at the beginning to merge rooms in for example active/passive users. However, the results of the regression analyses showed a tendency towards more classical parameters, such as indoor relative humidity, CO₂ concentration and outdoor temperature, which were monitored in all rooms.

As a second step, a division between active and passive users could be applied by merging data from rooms and deleting some not shared variables of the rooms, creating a passive and an active user model. Furthermore, it is also interesting to see if rooms with one occupant have a different common behaviour towards the one with two occupants.

Considering the results of the regression analysis (see table 1 and table 2) the opening and closing probabilities can be inferred by picking the rooms with the common predictors. For example, the room R3, R5 and R6 can be merged to see if the relative humidity can be considered as a reliable predictor in a more general opening behaviour. R1, R3 and R5 are useful to infer the CO₂ influence. For the closing probability, it could be interesting to have a complete database which comprises all the rooms in order to see if the outdoor temperature is a reliable predictor.

Considering that a logistic regression applied on a single room is not enough to depict an overall correlation between the air conditioner, the door switching and the window opening, the analysis will be only hypothesis of a possible implementation of the model into simulation software.

Moreover, the current research trend about occupants' behaviour is mainly focused on the analysis of the single device whereby users could interact. If we think about our daily behaviour in indoor environment, we realize that our reactions to thermal, visual or acoustic stimuli are sometimes correlated. For example, if we feel hot our direction could be to open a window or perhaps to turn on the air conditioner. Taking this into consideration, an integrated approach where probabilistic behavioural models define all the possible interactions between users and building controls (such as use of the window, heating and cooling set point adjustments, use of lighting and equipment), would be very useful. Furthermore this approach would help to get closer to a truthful evaluation of users' influence in modifying the energy performances of the building by considering probabilistic all the objects that imply human interaction.

6. CONCLUSIONS

The indoor temperature, indoor relative humidity and outdoor temperature had the highest influence on the window opening probability. The outdoor temperature influenced the closing probability in five of the seven rooms and had the highest magnitude in all five rooms. Contextual variables such as time of day and season also affected occupants' window opening behaviour. The VOC concentration had an effect in two of 4 rooms, but this effect was small compared to other factors. The occupancy state (arrival/intermediate/departure) had an effect on opening probability in four out of seven rooms while it only affected the closing probability in one room.

The variables indoor and outdoor temperature, indoor relative humidity and contextual variables such as occupancy state, turned out as the best predictors of occupants' window opening behaviour. As such any attempt to realistically model occupants' window operation in office buildings should be based on monitoring campaigns including measurements of at least these variables.

References

- Andersen R, Fabi V, Toftum J, Corngnati S.P, Olesen B.W, (2013), Window opening behaviour modelled from measurements in Danish dwellings. *Building and Environment* 69, 101-113.
- Bourgeois D, Hand J, McDonald I, Reinhart C, (2004), Adding sub-hourly occupancy prediction, occupancy-sensing control and manual environmental control to ESP-r. *Proceedings of eSim 2004, Vancouver, B.C., June 10-11*, pp. 119-126.
- Brundrett G.W, (1979) Window ventilation and human behaviour in PO Fanger and O. Valbjorn (eds.). *Proceedings 1st International Indoor Climate Symposium, Copenhagen*, pp. 317-325.
- Dick J.B, Thomas D.A, (1951), Ventilation research in occupied houses. *Journal of the Institution of Heating and Ventilating Engineers* 19(194), 279-305.
- Fritsch R, Kohler A, Nygard A, Ferguson M, Scartezzini J.L, (1990), A stochastic model of user behaviour regarding ventilation. *Building and Environment* 25 (2), pp. 173-181.
- Haldi F, Robinson D, (2008), On the behaviour and adaptation of office occupants. *Building and Environment* 43(12), 2163-2177.
- Haldi F, Robinson D, (2010), Adaptive actions on shading devices in response to local visual stimuli. *Journal of Building Performance Simulation*, 3(2): 135-153.
- Herkel S, Knapp U, Pfafferott J, (2005), A preliminary model of user behaviour regarding the manual control of windows in office buildings, *Clima2005, Proceedings of the 8th REHVA World Congress, Lausanne, Switzerland*.
- Herkel S, Knapp U, Pfafferott J, (2008), Towards a model of user behaviour regarding the manual control of windows in office buildings. *Building and Environment* 43, 588-600.
- Mahdavi A, Pröglhöf C, (2009), User behavior and energy performance in buildings. *Internationalen Energiewirtschaftstagung an der TU Wien, IEWT*.
- Nicol F, (2001), Characterising occupant behaviour in buildings: towards a stochastic model of occupant use of windows, lights, blinds, heaters and fans. *Building Simulation, Rio de Janeiro, August 13-15*.
- Nicol F, Humphreys M.A, (2004), A stochastic approach to thermal comfort- occupant behaviour and energy use in buildings, *ASHRAE Transactions* 110(2):554-568.
- Nicol F, Rijal H, Humphreys M, Tuohy P, (2007), Characterising the use of windows in thermal simulation. *2nd PALENC Conference and 28th AIVC Conference on Building Low Energy Cooling and Advanced Ventilation Technologies in the 21st Century, September 2007*.
- Rijal H.B, Tuohy P, Humphreys M. A, Nicol J. F, Samuel A, Clarke J, (2007), Using results from field surveys to predict the effect of open windows on thermal comfort and energy use in buildings. *Energy and Building* 39(7), 823-836.

Schweiker M, Shukuya M, (2009), Comparison of theoretical and statistical models of air-conditioning-usage behavior in a residential setting under Japanese climatic conditions. *Building and Environment*, 44: 2137-49.

Schweiker M, Haldi F, Shukuya M, Robinson D, (2012), Verification of stochastic models of window opening behaviour for residential buildings. *Journal of Building Performance Simulation*, Volume 5, Issue 1, 55-74.

Yun G.Y, Steemers K, (2010), Night-time naturally ventilated offices: Statistical simulations of window-use patterns from field monitoring. *Solar Energy* 84, 1216-1231.

Warren P.R, Perkins L.M, (1984), Window-opening behaviour in office buildings. *ASHRAE Transactions*, 1984, pp. 89-101.

A.P.Jones, Indoor air quality and health. (1999), *Atmospheric Environment*, 33, pp. 4535-4564

WINDSOR CONFERENCE 2014

COUNTING THE COST OF COMFORT

AFTER DINNER TALKS

Climate change and the limits of comfort
by Myles Allen

Turning up the heat – physiological implications of a changing thermal environment
by Wouter van Marken Lichtenbelt

Invited Chair: Michael Humphreys

WINDSOR CONFERENCE 2014

COUNTING THE COST OF COMFORT

SESSION 4

The physiology of thermal comfort

Invited Chairs: Lisje Schellen and Jacob Verhaart

Thermoregulatory behaviour in response to switching thermal environments – a pilot experiment prior to a mild warm acclimation study

Hannah Pallubinsky^{1,*}, Lisje Schellen^{1,2} and Wouter van Marken Lichtenbelt¹

¹Maastricht University Medical Center+, Department of Human Biology, NUTRIM School for Nutrition, Toxicology and Metabolism, Maastricht, The Netherlands, corresponding email: h.pallubinsky@maastrichtuniversity.nl;

²School of Built Environment and Infrastructure, Avans University of Applied Sciences, Tilburg, The Netherlands

Abstract

The indoor climate is an important factor with respect to human health and comfort since we spend most of our time, no matter if awake or asleep, in the built environment. Building occupants influence their thermal environments to maximize thermal comfort by inducing thermoregulatory behaviour. In the last decades, overheating of cities and buildings became an important issue. However, the effect of a mild hot environment on human thermoregulatory behaviour remains unclear.

To study the effects of a mild warm environment we propose a mild warm acclimation study. Part of this study is to investigate the effect of an alternated thermal environment on thermo-physiology and thermoregulatory behaviour before and after acclimation. In this paper we address the first results of a pilot study. The pilot aimed to elucidate interactions between human thermo-physiology, thermoregulatory behaviour and thermal comfort in response to altering thermal environments, the so-called SWITCH protocol. The pilot measurements demonstrate that thermoregulatory behaviour is initiated upon decreasing levels of thermal sensation and thermal comfort. Furthermore, we found indications for distinct thermoregulatory mechanisms in the three tested subjects, based on behaviour and skin temperatures.

Keywords: Thermoregulatory behaviour, thermal sensation, thermal comfort, mild heat acclimation, passive acclimation

1. Introduction

Human beings are almost constantly exposed to indoor climates and in the last decades, overheating of buildings has become an important issue. As, in the western world, heating, ventilating and air-conditioning of residential, commercial and public buildings consumes a lot of energy, this reveals the importance to reduce this energy use. A lot of progress has been made towards highly effective construction materials, which provide high standards of airtightness and insulation. However, as a result buildings might be at risk for overheating. Furthermore, global warming is progressing slowly but surely (IPCC, 2013).

The indoor climate of a building has an important impact on human metabolism: uncomfortable warm environments might cause sleepiness and restrict productivity, although this is not absolutely certain (de Dear et al., 2013). On the other hand, building occupants influence their thermal environment to maximize their individual

comfort: they open a window or put on a heater. Changes in skin and core temperature as well as conscious perception of thermal sensation and thermal comfort seem to drive this thermoregulatory behaviour (Chatonnet et al., 1966). A recent investigation by Schlader *et al.* (Schlader et al., 2013) indicates, that skin temperature plays the main role in initiating behaviour, whereas core temperature remains stable upon alternating exposure to cold (8°C) and heat (46°C). However, which parameters actually control thermoregulatory behaviour, which role local perception plays and which thresholds must be exceeded before individuals change their behaviour, still remains largely elusive.

Regarding the above stated environmental alterations, reactions and adaptations of the human metabolism upon (mild) hot environments are of significant interest. It is generally known that heat can cause stress to the human body, ranging from mild heat exhaustion to heat stroke. In order to prevent heat-related illness, plenty of studies investigated heat acclimation models. Importantly, the term *acclimation* stands for metabolic adaptation due to artificial temperature stimuli and should not be mixed up with the term *acclimatization* that represents naturally induced adaptations. Heat acclimation leads to several adjustments at various levels in the body (i.e. subcellular, cellular and organ level), which results in superior ability to dissipate heat. These adjustments can affect core temperature, sweat rate, the cardiovascular system and other metabolic functions. The adjustment is largely dependent on climatic conditions, duration and intensity of the thermal stimulus (Hori, 1995). Currently, acclimation models are mainly developed for athletes or the military. The majority of these models are active acclimation models: they use exercise-induced hypothermia in combination with elevated ambient temperatures. This is a logical consequence in consideration of the original application but it is complicated to distinguish between temperature and exercise-related adaptations. It is desirable to improve knowledge on heat acclimation due to passive (mild) heat exposure and the influences on human metabolism and thermoregulation, since evidence is limited and becomes important with respect to the issue of overheating. It is hypothesized, that prolonged exposure to mild heat causes alterations in thermoregulatory physiology (as widely accepted), and influences behavioural set points of thermoregulation and shift the perception of thermal comfort to higher ambient temperature.

We are planning to investigate the link between changes in physiology and human thermal comfort and thermoregulatory behaviour upon mild heat acclimation. Therefore, we performed a pilot experiment to investigate the relationships between thermoregulatory behaviour, thermo-physiology and thermal comfort, first without the influence of acclimation. The data of this pilot experiment is presented below.

2. Methods

Three subjects participated in the behavioural pilot experiment where they could switch between a cold and a hot condition. Their characteristics are summarized in Table 1.

2.1 Subjects

All subjects were healthy, normotensive, non-obese, non-smokers and not taking any medication, which might alter the cardiovascular or thermoregulatory responses. Subjects were only included if they were on oral contraceptives in order to prevent thermoregulatory influences of the menstrual cycle. The volunteers were given detailed information regarding the purpose and the methods used in the study, before written informed consent was obtained.

Table 1. Subject Characteristics.

	Subject 1	Subject 2	Subject 3	Mean \pm SD
Age (years)	23	24	24	23.67 \pm 0.58
Height (m)	1.65	1.70	1.73	1.69 \pm 0.04
Mass (kg)	58	62	59	59.67 \pm 2.08
BMI (kg/m ²)	21.30	21.45	19.71	20.82 \pm 0.96

Subjects refrained from eating and drinking of alcoholic and caffeinated beverages in the evening and morning prior to the test. After arrival at the laboratory, they put on standardized clothing. Clo values were determined using EN-ISO 9920 (2009) and McCollough *et al.* (McCullough, 1989). The total thermal resistance of the clothing ensemble, including desk chair, was calculated to be 0.4 clo. Twenty-six iButtons were attached to 14 ISO-defined and 12 more spots and recorded skin temperature in 1-minute-intervals.

2.2 Experimental protocol.

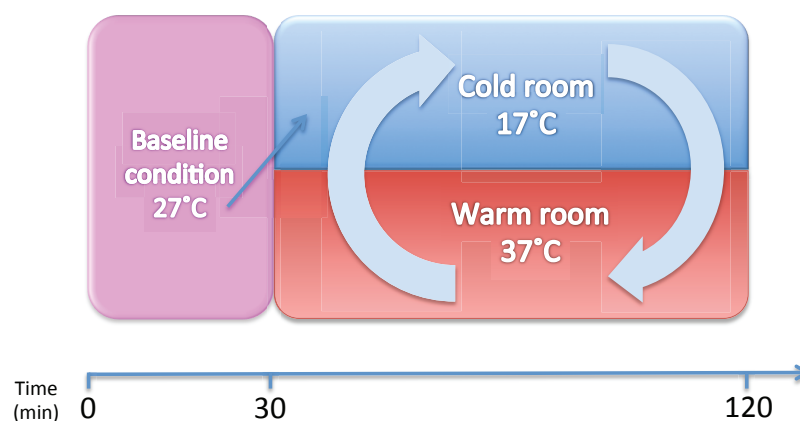

Figure 1. The SWITCH protocol: After 30 minutes of baseline, participants were free to change the conditions; there is no limit in time or frequency.

The SWITCH protocol (figure 1) consisted of a behavioural experiment in which the subjects chose between a hot (37°C) and a cold (17°C) condition. Subjects started in the baseline condition room (27°C ambient temperature). Throughout the whole

experiment, participants sat at a desk on a chair and were allowed to read a book or a magazine. Subsequently to the 30 minutes of baseline, subjects were brought to the hot room where they sat at a desk again. After the baseline period, participants were given the freedom to indicate thermoregulatory behaviour as indicated by switching between the two conditions (either cold or warm). After they indicated their desire by ringing a bell, they were replaced to the alternative room. This procedure was continued for 90 minutes. Importantly, subjects were told that the experiment should clearly be no competition of temperature perseverance, that they should try to behave in a natural way and that they should not hesitate to ring the bell when they would want to switch, whenever and as often as they would want to.

2.3 Measurements

Counting the switches and timing the duration (minutes) of persistence in one of the two alternative conditions indicated thermal behaviour. Twenty-six calibrated iButtons (DS1923, Maxim, USA) were attached to the skin with semi-adhesive tape (Fixomull stretch, BSM medical GmbH, Germany) at ISO-defined spots and recorded skin temperature in 1-minute intervals (accuracy $\pm 0.125^{\circ}\text{C}$). Ambient temperature was recorded by an iButton at 1.1m height next to the subject. TS and TC were assessed using our TherMU-VAS, which were completed using a web browser on tablet computer. The questionnaires were presented in Dutch language. During the baseline period, subjects completed the TherMU questionnaire, consisting of a 7-point VAS thermal sensation scale and thermal comfort VAS, on 15-minute intervals and on 6-minute intervals during the rest of the SWITCH protocol. An extra questionnaire was completed just before they switched the conditions, unless they completed one of the regular questionnaires immediately before the switch. Amongst others, the questionnaire included 7-point interval scales to assess global and local thermal sensation and thermal comfort (ISO, 2005). Microsoft Excel was used for data compilation and analysis.

3. Results

The main outcomes of this study were thermal behaviour, ambient and skin temperatures, thermal sensation and thermal comfort. The results per outcome are presented below.

3.1 Thermal behaviour

Thermal behaviour of the three subjects in the cold (C) and in the hot (H) has been indicated by the total amount of switches and the time (min) until the decision to switch. Subject 1 spent about two-thirds of the total exposure time in the cold condition (C=57min vs. H=33min). Subject 2 decided to stay two-thirds of the time in the hot condition (C=30min vs. H=60min). Subject 3 spent approximately the same amount of time both conditions (C=46 vs. H=44min). Subject 1 changed the rooms once (C→H) after 30 minutes of cold exposure. Subjects 1 and 3 decided to switch more often (3 vs. 6 times). The sequencing of switching, as well as, corresponding ambient temperature and skin temperature trends are depicted in figure 2.

The duration from entering the chamber until deciding to switch was longer at C→H (30 and 27 min C→H vs. 14 min H→C) in subject 1. Subject 3 spent more time in H before she decided to switch to C (18, 16 and 10 min H→C vs. 5, 5 and 4 min C→H). Since subject 2 switched one time only, it is not possible to make a statement on the time before decision between cold and hot.

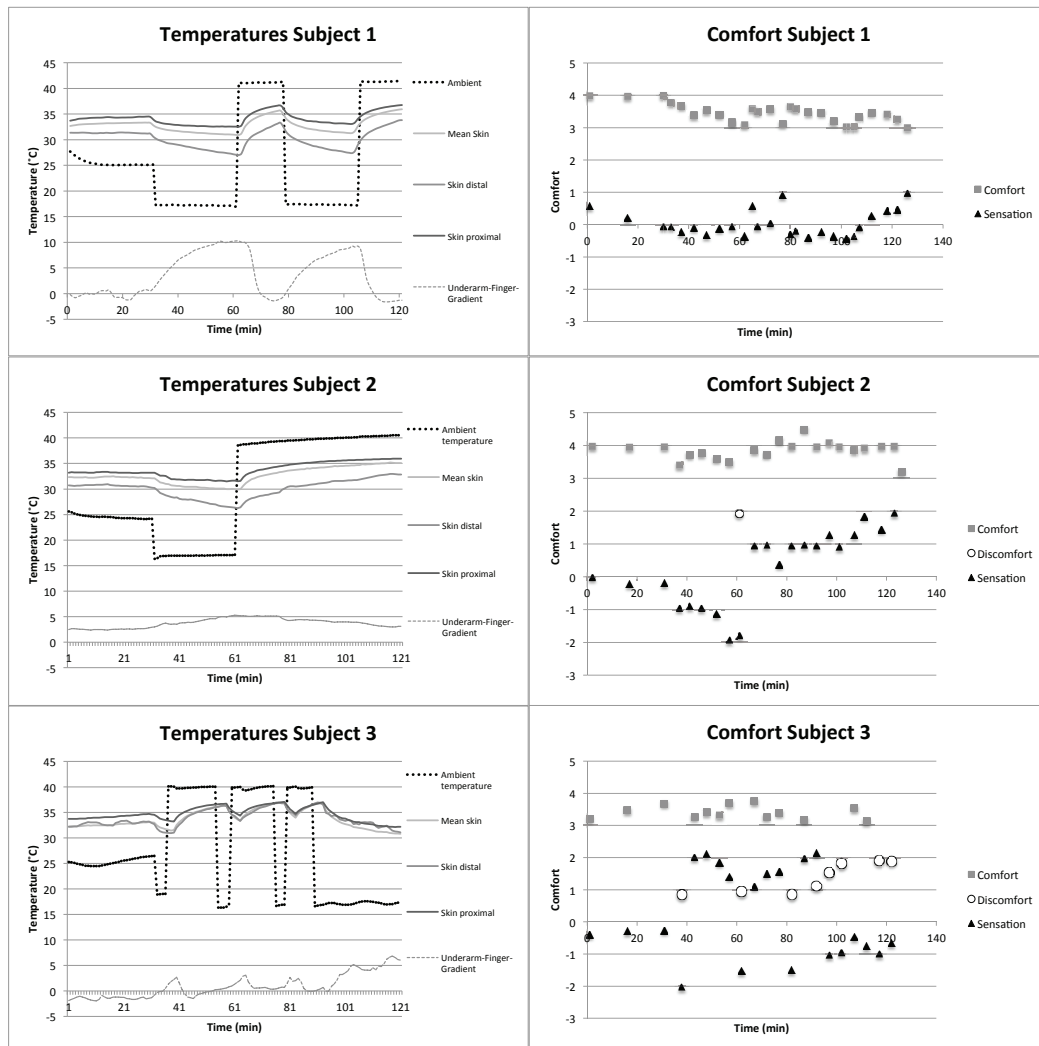

Figure 2. Ambient/skin temperatures, thermal comfort/discomfort and thermal sensation of subject 1, subject 2 and subject 3 during SWITCH. Ambient temperature also indicates switches between the conditions. Underarm-finger-gradient indicates the difference between distal skin temperatures (skin distal) and proximal skin temperatures (skin proximal). Thermal sensation data is represented on the 7-point thermal sensation scale ranging from -3 (cold) to +3 (hot). Thermal comfort data is represented on a 4-point scale; 0=very uncomfortable, 1=uncomfortable, 2=just comfortable, 3=just comfortable, 4=comfortable, 5=very comfortable.

3.2 Temperatures

Ambient temperature during baseline was $25.11 \pm 0.49^\circ\text{C}$, $40.28 \pm 0.82^\circ\text{C}$ in the hot room and $17.09 \pm 0.17^\circ\text{C}$ in the cold. Skin temperatures of all three subjects during hot and cold conditions are presented in Figure 2 and Table 2.

Table 2. Skin temperatures (averages) during baseline, cold and hot condition. Values are presented as mean \pm SD and are averages over all time spent in the respective condition.

Baseline	Subject 1	Subject 2	Subject 3	SD (between subjects)
Mean skin ($^\circ\text{C}$)	33.1	32.3	32.6	0.4
Skin distal ($^\circ\text{C}$)	31.3	30.7	32.8	1.1
Skin proximal ($^\circ\text{C}$)	34.3	33.2	34.2	0.6
Skin gradient proximal-distal ($^\circ\text{C}$)	3.0	2.6	1.3	0.9
Underarm-finger gradient ($^\circ\text{C}$)	-0.1	-2.1	-1.4	1.0
Cold				
Mean skin ($^\circ\text{C}$)	31.8	30.5	33.5	1.5
Skin distal ($^\circ\text{C}$)	28.6	27.8	33.8	3.3
Skin proximal ($^\circ\text{C}$)	33.2	31.9	34.3	1.2
Skin gradient proximal-distal ($^\circ\text{C}$)	4.6	4.2	0.5	2.3
Underarm-finger gradient ($^\circ\text{C}$)	7.0	1.9	2.7	2.7
Hot				
Mean skin ($^\circ\text{C}$)	34.6	33.8	34.9	0.5
Skin distal ($^\circ\text{C}$)	31.7	30.7	34.8	2.1
Skin proximal ($^\circ\text{C}$)	35.7	34.9	35.6	0.4
Skin gradient proximal-distal ($^\circ\text{C}$)	4.0	4.2	0.8	1.9
Underarm-finger gradient ($^\circ\text{C}$)	1.7	1.2	0.8	0.5

In subjects 1 and 2, mean skin temperature decreased in C and increased in H, compared to baseline. In subject 3, the average of mean skin temperature during C and H were higher compared to baseline levels. Subject 3 exhibited the highest distal skin temperatures during all three conditions. Furthermore, subject 3 had the smallest differences between proximal and distal skin temperatures during baseline, H and C. Underarm-finger-gradient (UFG) can be considered as an indicator for vasodilation (negative values and values tending towards 0) and vasoconstriction (positive values). UFG shifted most between baseline and C measurements in subject 1, which is clearly visible in figure 1 as well.

3.3 Thermal Sensations and Thermal Comfort

During the pilot experiment, subjects had to rate thermal sensation (TS) and thermal comfort (TC) continuously. TS was rated on a continuous 7-point ASHRAE scale ranging from -3 (very cold) to 0 (neutral) and to 3 (very hot). TC was indicated on a split visual analogue scale to distinguish between comfort and discomfort (0-2 for discomfort and 3-5 for comfort). Thus, high values reflected high levels of thermal comfort.

The trends of TS and TC during the experiment of all three subjects are provided in figure 2. Whereas subject 1 always marked TS between “a little hot” and “a little cold” and never indicated the feeling of discomfort throughout the whole experiment, subject 3 fluctuated between “hot” and “cold” and indicated discomfort in 8 (of 21) questionnaires. Subject 2 also indicated TS between “hot” and “cold” but discomfort was stated once only.

4. Discussion

The present pilot study aimed to test a protocol on thermoregulatory behaviour and thermal comfort. Subjects underwent an experimental setting with two distinct thermal conditions of approximately 17°C and 40°C. Subjects were given the freedom to switch between these two conditions without any given limits in time or frequency.

4.1 Thermal behaviour and thermal comfort

Since all subjects switched at least once, we suppose that the two temperatures were extreme enough to allure thermoregulatory behaviour. Although all subjects were of comparable age, height and weight, they exhibited different behaviour upon the provided thermal environments. Subject 2 seemed to be content with a wide range of temperatures, since she switched only once after a relatively long stay in H. In contrast, subject 3 decided to change the conditions for six times in 90 minutes of exposure.

Thermal comfort seemed to be appropriately related to thermoregulatory behaviour, indicated by the extent of discomfort (figure 2). Subject 2 switched only once and indicated the feeling of discomfort immediately before changing the conditions. Subject 3, who performed most switches, also indicated discomfort in eight of the 21 questionnaires. Although subject 1 did not report the feeling of discomfort, a trend towards decreasing thermal comfort in the minutes just before she switched were evident. The same trends can be observed in thermal sensation (TS) among all three subjects. If TS tended to increase or decrease towards “cool” (-2) or “warm” (2), subjects were prone to switch. These findings suggest that, on the one hand, subjects experience the thermal environment differently. Time spent in one condition seems to be an important factor since subjects perceived discomfort after different time spans (subject 3 felt uncomfortable very quickly; subject 1 did not feel uncomfortable at all). On the other hand, all subjects tended to perform behaviour (in form of switching), when TS reached the feeling of “hot” or “cold”. Our findings therefore partially agree with other studies that conducted similar behavioural protocols. Schlader *et al.* demonstrated before, that the feeling of “discomfort” is important in the conductance of behavioural thermoregulation (Schlader *et al.*, 2013). The results furthermore suggest that the subjects have individual thermal-comfort-ranges. Recently, Jacquot *et al.* (accepted for publication) indicated, that individuals could be categorized based on their individual thermal preference (Jacquot *et al.*, 2014). Jacquot found significant differences between individuals with “broad range of temperatures preference” and “narrow range of temperatures preference”. These categories seem to be applicable for the three subjects of the pilot-measurement as well: roughly, we could classify subjects 1 and 2 as individuals with a broad range of preferred temperatures and subject 3 as an individual with a narrow range of preferred temperatures.

4.2 Thermal behaviour and physiological responses

Interestingly, the three subjects seemed to have distinct reactions of skin temperature upon thermal exposure.

In subject 1 and 2, mean skin temperature shifted alongside with ambient temperature but in subject 3, mean skin temperature was higher in both H and C compared to baseline. This might be due to the fact, that in the first 60 minutes of SWITCH, subject 3 remained longer in the hot room than in the cold and thus, skin temperature did not decrease remarkably compared to baseline. It is furthermore noticeable, that based on figure 2, skin temperatures of subject 1 and 2 immediately decrease or increase upon ambient temperature change, whereas subject 3 seems to have a sort of delay in adaptations of skin temperature. Taking all these findings into account, the three subjects seem to have distinct physiological reactions upon thermal environmental changes.

In the future, we are going to measure more physiological indicators such as energy expenditure, skin conductance and sweat rate to provide insight into the relationships between physiological parameters and behavioural thermoregulation.

6. References

- CHATONNET, J., THIERS, H., CABANAC, M. & PASQUIER, J. 1966. [On the origin of conscious impression of thermal comfort]. *Lyon Med*, 216, 1387-92.
- DE DEAR, R. J., AKIMOTO, T., ARENS, E. A., BRAGER, G., CANDIDO, C., CHEONG, K. W. D., LI, B., NISHIHARA, N., SEKHAR, S. C., TANABE, S., TOFTUM, J., ZHANG, H. & ZHU, Y. 2013. Progress in thermal comfort research over the last twenty years. *Indoor Air*, 23, 442-461.
- HORI, S. 1995. Adaptation to heat. *The Japanese journal of physiology*, 45, 921-946.
- IPCC 2013. Climate change 2013 - The physical science basis. In: STOCKER, T. F., QIN, D., PLATTNER, G.K., TIGNOR, M.M.B., ALLEN, S., BOSCHUNG, J., NAUELS, A., XIA, Y., BEX, V., MIDGLEY, P.M. (ed.) *Working Group I Contribution to the Fifth Assessment Report of the Intergovernmental Panel on Climate Change*. Switzerland: Intergovernmental Panel on Climate Change.
- ISO 2005. *7730 Ergonomics of the Thermal Environment - Analytical Determination and Interpretation of Thermal Comfort Using Calculation of the PMV and PPD Indices And Local Thermal Comfort Criteria*, Geneva, International Standards Organization.
- ISO, I. S. O. 2009. EN-ISO 9920: Ergonomics of the thermal environment - estimation of thermal insulation and water vapour resistance of a clothing ensemble.
- JACQUOT, C. M. C., SCHELLEN, L., KINGMA, B. R. M., BAAK, M. & VAN MARKEN LICHTENBELT, W. D. 2014. Influence of thermophysiology on thermal behavior: the essentials of categorization. *Physiology & Behavior*, in press.
- MCCULLOUGH, E. A. 1989. A data base for determining the evaporative resistance of clothing. *ASHRAE Trans*, 95, 316-328.
- SCHLADER, Z. J., PERRY, B. G., JUSOH, M. R., HODGES, L. D., STANNARD, S. R. & MUNDEL, T. 2013. Human temperature regulation when given the opportunity to behave. *Eur J Appl Physiol*, 113, 1291-301.

The relation between the thermoneutral zone and thermal comfort zone - *Determination of the thermoneutral zone and the influence on thermal behaviour*

Lisje Schellen^{1,2}, Hannah Pallubinsky¹ and Wouter van Marken Lichtenbelt¹

1 Department of Human Biology, NUTRIM, Maastricht University, The Netherlands,
correspondence email: L.Schellen@maastrichtuniversity.nl

2 School of Built Environment and Infrastructure, Avans University of Applied Sciences,
Tilburg, The Netherlands

Abstract

The thermoneutral zone (TNZ) reflects the range of ambient temperatures where no regulatory changes in metabolic heat production or evaporative heat loss occur. Indications exist that the ambient temperature range wherein a subject is feeling thermal comfortable, i.e. the thermal comfort zone (TCZ), is larger compared to the TNZ. From both the building energy-use and a health perspective this could be highly beneficial. The objective of this study is to explore the TNZ and TCZ of individual subjects, in relation to a given range of ambient temperatures. Within this study a method is developed to measure the TNZ. Subjects are exposed to two different protocols, during both protocols a drift of $\pm 10\text{K/h}$ in ambient temperature is studied. According to the preliminary results it is possible to determine the TNZ of the subjects. Furthermore, a relation between TNZ, TCZ and the temperature preference of subjects can be observed. This approach links individual thermo-physiological properties to thermal comfort and thermal behaviour and will reveal important information for the energy use of buildings regarding user behaviour and user profiles.

Keywords: Thermo-physiology, Thermal comfort (zone), Thermoneutral zone, Thermal preference, Thermal behaviour

1 Introduction

To arrive at comfortable conditions indoors energy is required generally. About one-third of the primary energy used in developed countries is currently consumed in the built environment, for a large share by heating, ventilating, air conditioning and lighting in residential, commercial and public buildings (Agency, 2007). This reveals a high importance to reduce the energy use in buildings. Therefore, predictions of the building energy consumption are necessary. However, the predicted energy use often significantly deviates from the actual energy used (Branco et al., 2004, Haas et al., 1998). This difference may be explained by the thermoregulatory behaviour of the occupants (Santin et al., 2009, Branco et al., 2004). Thermoregulatory behaviour is influenced by changes in thermal sensation and thermal comfort (Schlader et al., 2011). However, relatively little is known which (thermo)physiological parameters drive thermoregulatory behaviour, and in turn thermal comfort.

In this study it is hypothesized that the thermoneutral zone (TNZ) has an influence on thermoregulatory behaviour.

The thermoneutral zone (TNZ) is defined as the range of ambient temperatures without regulatory changes in metabolic heat production or evaporative heat loss. In a steady state

environment a person can only be within the TNZ when heat production and heat losses are in balance. Within the TNZ, resting energy expenditure (EE) is known as basal metabolic rate (BMR). Above or below the TNZ metabolic rate increases due to a change in ambient temperature (figure 1).

A recent literature study by Kingma et al. (2012) shows that the TNZ zone is affected by several factors, e.g. body composition, energy metabolism, age, gender, physical activity and clothing. Therefore, TNZ varies between different sub-populations.

Furthermore, indications exist that the ambient temperature range wherein a subject is feeling thermal comfortable, i.e. the thermal comfort zone (TCZ), is larger compared to the TNZ (van Marken Lichtenbelt and Kingma, 2013). From both health and building energy-use perspectives this could be highly beneficial (van Marken Lichtenbelt and Kingma, 2013).

Since, the TNZ and TCZ appear to be correlated to each other it is therefore hypothesized that the width and positioning of the TNZ has an influence on thermoregulatory behaviour on inter-individual level. Therefore, it is relevant to determine the TNZ of individual subjects.

Within this study a method is developed to determine the TNZ of individual subjects. Such a protocol has not yet been described before for humans.

Since the study is on-going, the first preliminary results of 6 subjects will be presented in this paper. It is expected that at the time of the conference all measurements will be completed.

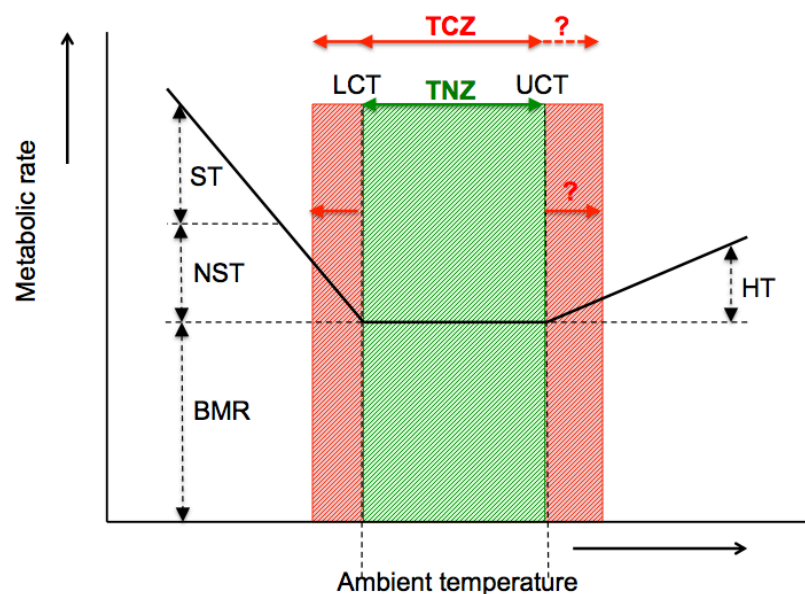

Figure 1. The thermoneutral zone (TNZ) reflects the ambient temperature range where the energy expenditure rate is at basal level (basal metabolic rate, BMR) and there are no thermoregulatory changes in metabolic rate (non-shivering thermogenesis, NST; shivering thermogenesis, ST; or heat-related thermogenesis, HT) or sweating. Below the lower critical temperature (LCT) metabolic heat production increases and above the upper critical temperature (UCT) sweating occurs due to a respectively decrease or increase in ambient temperature. The relation as depicted is mainly derived from animal studies. For the cold side data is available from human studies. For the warm side little is known until now, and the relation is complex due to an interaction of sweating and increase in metabolic rate.

The thermal comfort zone (TCZ) represents the range of ambient temperatures wherein a subject is feeling thermal comfortable (adapted from (van Marken Lichtenbelt and Kingma, 2013)).

2 Methods

In order to determine individual TNZs a climate room set-up with experimental subjects is used. The measurements are conducted in the respiration chambers of the Maastricht University. In total 16 healthy female subjects will visit the laboratory on two occasions for two different protocols. Subjects were taking oral contraceptives and were not measured during their menstruation period to standardize hormonal effects on thermoregulation. The subject characteristics are summarized in Table 1.

The volunteers were given detailed information regarding the purpose and the methods used in the study, before written informed consent was obtained. The protocol was approved by the ethics committee of Maastricht University Medical Centre+ and performed according to the Declaration of Helsinki.

Table 1. Subject characteristics

Age (year)	26.1 ± 4.17
Height (cm)	171.7 ± 0.06
Mass (kg)	63.7 ± 6.39
BMI (kg/m ²)	21.6 ± 1.35
Bodyfat% (%)	25.7 ± 4.95

Values are presented as mean ± SD (n=6)

2.1 Study protocol

Subjects will be exposed on two different days to two different protocols, 1 and 2, consisting of an increasing and decreasing temperature drift ($\pm 10\text{K/h}$) (Figure 2). Each protocol starts with a baseline measurement at a thermoneutral level (30°C) for one hour. During protocol 1 the temperature will increase in 1h from a thermoneutral temperature (30°C) to a warm ambient temperature (40°C). During protocol 2 the temperature will decrease in 1,5h from a thermoneutral temperature (30°C) to a mild cold (15°C) ambient temperature. Each subject completed the experimental protocols in balanced order. Two protocols are necessary because the cold and warm side of the TNZ need to be measured separately.

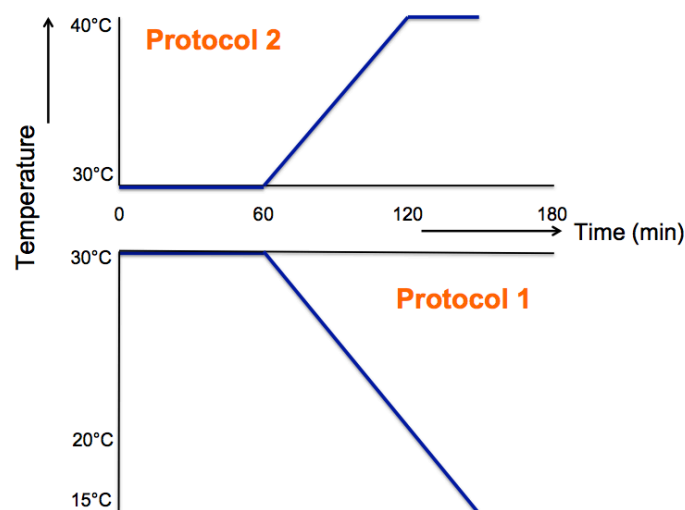

Figure 2. Measurement protocol 1 (increasing temperature drift, $+10\text{K/h}$) and 2 (decreasing temperature drift, -10K/h)

2.2 Measurements

During the measurements subjects are semi-nude in supine position. Energy expenditure is measured through indirect calorimetry. Skin temperatures are measured at 26 body sites (Schellen et al., 2012) using wireless sensors (accuracy $\pm 0.125^{\circ}\text{C}$) which were attached to skin using semi-permeable adhesive tape. Mean skin temperature is calculated based on the 14 point weighing proposed by EN-ISO 9886 (2004). Core temperature is measured using a telemetric pill (accuracy $\pm 0.1^{\circ}\text{C}$), ingested one hour previous to the start of the experiment. Skin blood flow is measured at 4 body sites (hand, underarm, abdomen and toe) using laser Doppler flowmetry.

Air temperature and relative humidity were measured according to NEN-EN-ISO 7726 (2001) at 0.1, 0.6, 1.1 and 1.7 m height next to the subject.

2.3 Questionnaires

Thermal behaviour, sensation and comfort are measured on a 6-minute interval using the TherMU questionnaire. The questionnaire includes, among others, 7-point interval scales to assess global and local thermal sensation, questions regarding the acceptability of the thermal environment, and Visual Analogue Scales (VAS) to assess the importance to change and rate of sweating and shivering (EN-ISO, 2005) (Kildeso et al., 1999). The questionnaires were presented in Dutch to the subjects through an Internet browser. A commercially available statistical software package (PASW Statistics 21.0, SPSS Inc., Chicago, USA) is used to analyse the data.

3 Results

3.1 Physiological responses

In table 1 the averaged mean, distal and proximal skin temperatures and core temperature are represented. Skin temperatures are significantly different between the protocols (t-test, $P < 0.001$).

Table 1: Mean, distal, and proximal skin temperatures and core temperature during both protocols including baseline period

Variable	Protocol 1	Protocol 2
Mean skin temperature [$^{\circ}\text{C}$]	32.7 \pm 2.0	34.5 \pm 0.9*
Distal skin temperature [$^{\circ}\text{C}$]	30.4 \pm 2.7	33.1 \pm 1.4*
Proximal skin temperature [$^{\circ}\text{C}$]	33.5 \pm 2.0	35.1 \pm 0.9*
Core temperature [$^{\circ}\text{C}$]	37.7 \pm 1.0	37.2 \pm 1.1

Values are presented as mean \pm SD, n=6, * significant ($P < 0.001$) different from protocol 1

3.2 Determination of the thermoneutral zone (TNZ)

The thermoneutral zone is defined as the range of ambient temperatures without regulatory changes in metabolic heat production or evaporative heat loss, i.e. the range in ambient temperatures where energy expenditure is at a constant level.

In Figure 3 the results of two typical subjects are represented. In this figure energy expenditure is related to the ambient temperature at 0.6m (subject position) and a distinction

is made for both protocols. The dotted lines represent the critical limits with respect to the TNZ. The TNZ for subject 3 the TNZ ranges from 28.0-32.1°C, and subject 5 from 22-32.4°C.

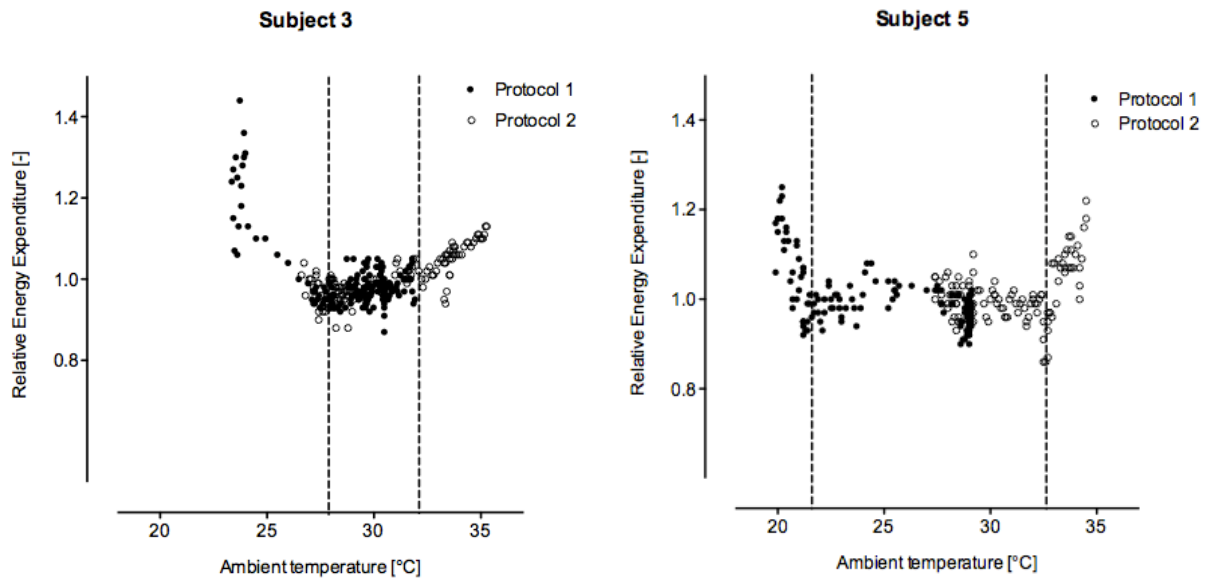

Figure 3. Normalized energy expenditure vs. ambient temperature for two typical subjects. The black dotted lines represent the upper and lower critical temperatures of the TNZ.

3.3 Thermoneutral zone (TNZ) vs. thermal comfort zone (TCZ)

In figure 4 the thermal comfort zone (TCZ) is represented in relation to the TNZ for two typical subjects. For subject 3 no clear lower critical temperature can be distinguished, the upper critical temperature equals 35.0°C. For subject 5 the TCZ ranges between 24.4-35.1°C

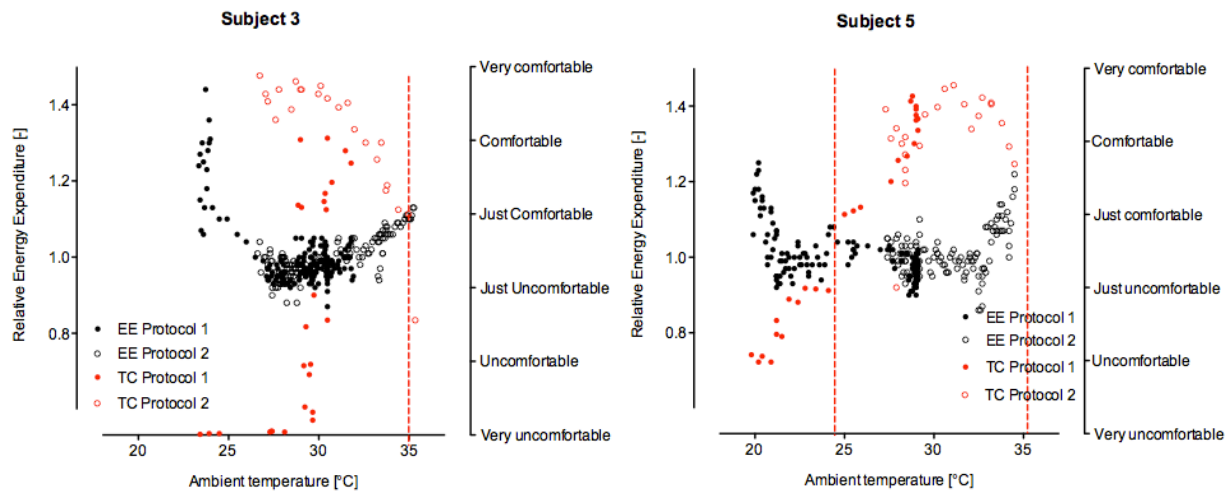

Figure 4. Normalized energy expenditure vs. ambient temperature vs. thermal comfort for two typical subjects. The red dotted lines depict the upper and lower critical temperatures of the TNZ. The black dots represent the energy expenditure data and the red dots represent the thermal comfort data.

3.4 TNZ in relation to thermal behaviour

The hypothesis of this study is that the TNZ of individual subjects can be used to explain thermal behaviour. In a recently published study we have shown that thermal behaviour can be explained by thermal preference and thermal sensation of the subjects, indicated by among others the strong correlation between preference and sensation (Jacquot et al., 2014). The current study again shows that these two parameters are strongly correlated (Figure 5).

Therefore, thermal sensation is regarded as an important parameter to predict thermal behaviour. To test the assumption that the TNZ is linked to thermal behaviour, the data of the TNZ and thermal sensation for the two same typical subjects (3 and 5) are analysed (Figure 6). For subject 3 the results show a relation between the warm side of the TNZ and thermal sensation, i.e. beyond the upper critical TNZ temperature (black dotted line) the thermal sensation exceeds the upper thermal sensation boundary (blue dotted line) according to the EN-ISO 7730 (2005) standard. However, for subject 5 no clear relation between TNZ and thermal sensation can be observed.

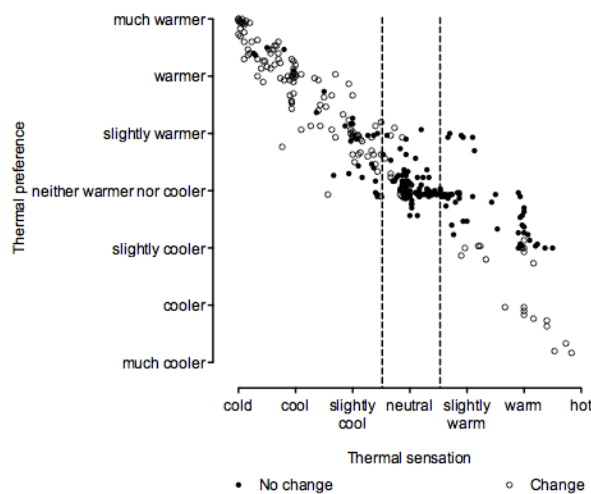

Figure 5. Thermal preference vs. thermal sensation. The open dots represented the data where the subject actually wanted to change their thermal environment (intention to change)

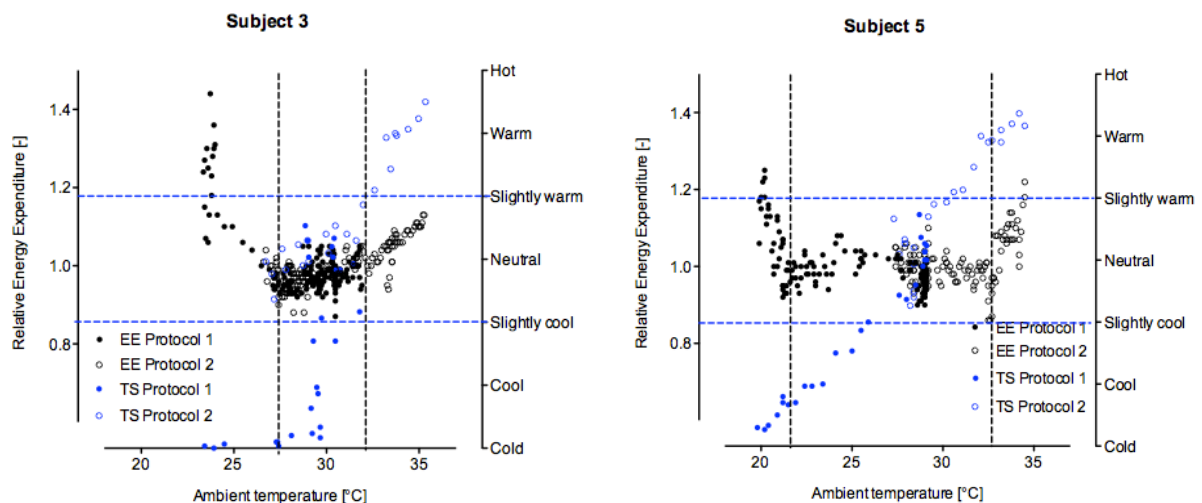

Figure 6. Normalized energy expenditure vs. ambient temperature vs. thermal sensation for two typical subjects. The blue dotted lines depict the thermal comfort boundaries from the EN-ISO 7730 standard (2005). The black dotted lines represent the upper and lower critical temperatures of the TNZ. The blue dots depict thermal sensation data assessed on the 7-point thermal sensation scale and the black dots represent the normalized energy expenditure data.

4 Discussion

Within this study the objective is to determine the thermoneutral zone (TNZ) and the thermal comfort zone (TCZ) of individual subjects. The hypothesis is that thermoregulatory behaviour of individuals can be explained according to their TNZ and TCZ. In order to be able to make realistic building energy predictions it is indispensable to include the thermal behaviour of occupants (Branco et al., 2004, Haas et al., 1998).

Within this paper preliminary results (6 out of 16 subjects) are presented. Subjects were exposed to two different protocols; an increasing (+10K/H) and a decreasing (-10K/h) temperature drift.

Although subjects are similar from a morphological point of view (Table 1), the first results indicate that there exist significant differences in thermal comfort, sensation, and behaviour in relation to the ambient temperature (Figure 3,4, and 6). Two typical subjects were selected for a detailed analysis. For subject 3 a relatively small (28.0-32.1°C) TNZ can be determined, where for subject 5 a relatively large (22.0-32.4°C) TNZ can be observed. With respect to the TCZ it is difficult to define the lower critical temperature for subject 3. This subject voted both comfort and discomfort at within a small range of ambient temperatures in the TNZ. For subject 5 the TCZ ranges from 24.4-35.1°C. For both subjects the TCZ is larger compared to the TNZ on the warm side of the TNZ. For the cold side of the TNZ the TCZ is smaller. However, in a previous study of our research group it is shown that after a short cold acclimation period of ten days, the TCZ can be significantly enlarged (van der Lans et al., 2013). From both health and building energy perspectives these results can be highly beneficial (van Marken Lichtenbelt et al., 2014). Furthermore, the results presented here support the hypothesis that the TCZ can be larger than the TNZ.

Another objective of this study was to develop a method to determine the TNZ of individual subjects, as this was not yet available for humans. All current TNZ data is obtained from animal studies. In the first pilot studies we tested slower temperature drifts (± 5 K/h). However, the results showed no significant increases in energy expenditure during the drifts. Therefore it was decided to increase the temperature slopes. According to the results presented here, the developed protocols provide information on the TNZ. However, future analysis should further elaborate on this, especially on the effects of hysteresis.

Acknowledgements

The authors would like to express their gratitude to the staff of the laboratory and MRUM for their assistance and the subjects who participated in the study. This study is financially supported by AgentschapNL (EOS-LT 10033 project INTEWON and TKI-UCER).

References

- INTERNATIONAL ENERGY AGENCY 2007. *ECBCS* [Online]. Available: <http://www.ecbcs.org>.
- BRANCO, G., LACHAL, B., GALLINELLI, P. & WEBER, W. 2004. Predicted versus observed heat consumption of a low energy multifamily complex in Switzerland based on long-term experimental data. *Energy Build*, 36, 543-555.
- HAAS, R., AUER, H. & BIERMAYR, P. 1998. The impact of consumer behavior on residential energy demand for space heating. *Energy Build*, 27, 195-205.
- JACQUOT, C. M. C., SCHELLEN, L., KINGMA, B. R. M., BAAK, M. & VAN MARKEN LICHTENBELT, W. D. 2014. Influence of thermophysiology on thermal behavior: the essentials of categorization. *Physiology & Behavior*, in press.

- KILDESO, J., WYON, D., SKOV, T. & SCHNEIDER, T. 1999. Visual analogue scales for detecting changes in symptoms of the sick building syndrome in an intervention study. *Scandinavian Journal of Work Environment & Health*, 25, 361-367.
- KINGMA, B., FRIJNS, A. & VAN MARKEN LICHTENBELT, W. 2012. The thermoneutral zone: implications for metabolic studies. *Frontiers in Bioscience*, E4, 1975-1985.
- LICHTENBELT, W. V., KINGMA, B., VAN DER LANS, A. & SCHELLEN, L. 2014. Cold exposure - an approach to increasing energy expenditure in humans. *Trends Endocrinol Metab*.
- EN-ISO 2001. ISO 7726: Ergonomics of the thermal environment - Instruments for measuring physical quantities.
- EN-ISO 9886: Ergonomics - Evaluation of thermal strain by physiological measurements.
- EN-ISO 2005. ISO 7730: Ergonomics of the thermal environment - Analytical determination and interpretation of thermal comfort using calculation of the PMV and PPD indices and local thermal comfort criteria.
- SANTIN, O. G., ITARD, L. & VISSCHER, H. 2009. The effect of occupancy and building characteristics on energy use for space and water heating in Dutch residential stock. *Energy Build*, 41, 1223-1232.
- SCHELLEN, L., LOOMANS, M. G., DE WIT, M. H., OLESEN, B. W. & VAN MARKEN LICHTENBELT, W. D. 2012. The influence of local effects on thermal sensation under non-uniform environmental conditions--gender differences in thermophysiology, thermal comfort and productivity during convective and radiant cooling. *Physiology & Behavior*, 107, 252-61.
- SCHLADER, Z. J., SIMMONS, S. E., STANNARD, S. R. & MUNDEL, T. 2011. The independent roles of temperature and thermal perception in the control of human thermoregulatory behavior. *Physiol Behav*, 103, 217-24.
- VAN DER LANS, A. A., HOEKS, J., BRANS, B., VIJGEN, G. H., VISSER, M. G., VOSSelman, M. J., HANSEN, J., JORGENSEN, J. A., WU, J., MOTTAGHY, F. M., SCHRAUWEN, P. & VAN MARKEN LICHTENBELT, W. D. 2013. Cold acclimation recruits human brown fat and increases nonshivering thermogenesis. *J Clin Invest*, 123, 3395-403.
- VAN MARKEN LICHTENBELT, W. D. & KINGMA, B. R. M. 2013. Building and occupant energetics: a physiological hypothesis. *Architectural Science Review*.

Proceedings of 8th Windsor Conference: *Counting the Cost of Comfort in a changing world* Cumberland Lodge, Windsor, UK, 10-13 April 2014. London: Network for Comfort and Energy Use in Buildings, <http://nceub.org.uk>

Versatile Indian sari: Clothing insulation with different drapes of typical sari ensembles

Madhavi Indraganti^{1,3}, Juyoun Lee^{2,3}, Hui Zhang^{3,4}, Edward A. Arens^{3,5}

¹ Fulbright Visiting Researcher, maindraganti@gmail.com

² HAE R&D Center, LG Electronics, South Korea, juyoun.lee@berkeley.edu

³ Center for the Built Environment (CBE), University of California, Berkeley, CA

⁴ zhanghui@berkeley.edu, ⁵ earens@berkeley.edu

Abstract

The sari is everyday attire for most women throughout the year all across South-Asia. It is a versatile ensemble because, a single set of garments can provide different levels of insulation just by changing the drape.

We tested three Indian ensembles of saris (for four drapes) with a thermal manikin following ISO: 9920 protocols. The insulation on all the sixteen body parts and the whole-body were recorded. This provides information for advanced thermal comfort modelling needing clothing insulation at segmentation level. The sari offered a wide range of insulation (0.94 to 0.62) for a given set of garments. Winter ensembles provided 1.11 – 1.39 clo while the summer and monsoon ensembles had 0.62 – 0.96 clo.

Keywords: India; Sari; Clothing Insulation; Thermal Comfort standards; Thermal Manikin

1 Introduction

1.1 The sari

Derived from its Sanskrit origin ‘śāṭī’, the word ‘sari’ means a strip of cloth. Historic literature points towards the use of this garment even during the Indus Valley civilization in circa 3000 BC. India has a very long and rich textile tradition. The saris vary in style, material and embellishment across the regions and cultures (Fig. 1). Unlike the western outfits, only women wear the saris.

1.2 Review of literature

Clothing is one of the six primary variables that affect human thermal comfort in any environment. Evaluation of human thermal comfort using simulation models requires information on the clothing insulation of the occupants. The sari is an important ensemble worn regularly by most women in South Asia and in some other parts of the world (Fig. 1).

A recent large-scale yearlong field study in 28 Indian offices has shown that 99% of Indian women are dressed in Indian ensembles (Indraganti, et al., 2013; Indraganti, et al., 2014) (Fig. 2). However, knowledge on the sari’s clothing insulation is very limited in the current codes (ASHRAE, 2010; BIS, 2005; ISO:9920, 2004). ASHRAE standards carry the clo values of many western-style ensembles only. Recent literature features information on the Arabian-gulf clothing and Asian and African clothing (Al-ajmi, et al., 2008; Mitsuzawa & Tanabe, 2001) and some data on the Indian sari.

The recent experiments conducted by Havenith et al. focus on non-western clothing, including two sari ensembles. They provide data on the two ensembles tested (Havenith, et al., 2014). A study in Japan also reported the clo value of the sari (Mitsuzawa & Tanabe, 2001). Havenith et al., (Havenith, et al., 2002) noted looser fit of the Middle Eastern clothing promoting air movement around the body, affecting the thermal comfort. These studies do not focus much on the sari as an ensemble with its various drapes, as are worn by most women in Indian offices and homes.



Figure 1. Indian workingwomen in sari ensembles draped in ‘nivi’ style with pleats in the lower center front (Left to right: Alternate women displaying pleated and un-pleated pallus, with the drape changing the body surface area exposed).



Figure 2. Typical office women employees dressed in the sari ensemble draped in ‘nivi’ style with pleated and un-pleated pallu as found in a field study in summer and monsoon seasons in India.

A unique feature of sari is that it changes the insulation level significantly just by adjusting the drapes, and there are many ways to drape the upper body and lower body. The drape of the ensemble depends on several factors including, weather, occasion, and activity of the person and it alters the microclimate around various body parts (Fig.1, 2). Indraganti (Indraganti, 2010) observed the subjects in a field study adjusting their saris in several ways to accommodate the changing thermal regimes and metabolic activities, there by adjusting the clothing insulation. It may be

worthwhile to know about the dress habits observed in the same space, as it may affect the design decisions.

The summation relationships for the pieces of an ensemble observed for western clothing may not be applicable for the Indian sari, as the material, fit, body coverage and drape and design are very different.

Moreover, the design of appropriate indoor environmental control systems mandates the knowledge and accurate estimation of clothing insulation of the building users. These design decisions in turn influence not only the thermal acceptability of the users but also the energy consumption on the whole.

Therefore, it is essential to obtain clothing insulation of the sari as an ensemble in a systematic manner. This information would also add value to the indoor environmental design of buildings, aircrafts, passenger railway coaches, and automobiles in addition.

Clothing insulation research in the past provided data only for the body as a whole (McCullough & Jones, 1983; Havenith, et al., 2002; ISO:9920, 2004). Human physiology and thermal comfort models treated the human body surface as one segment earlier (Gagge, et al., 1986).

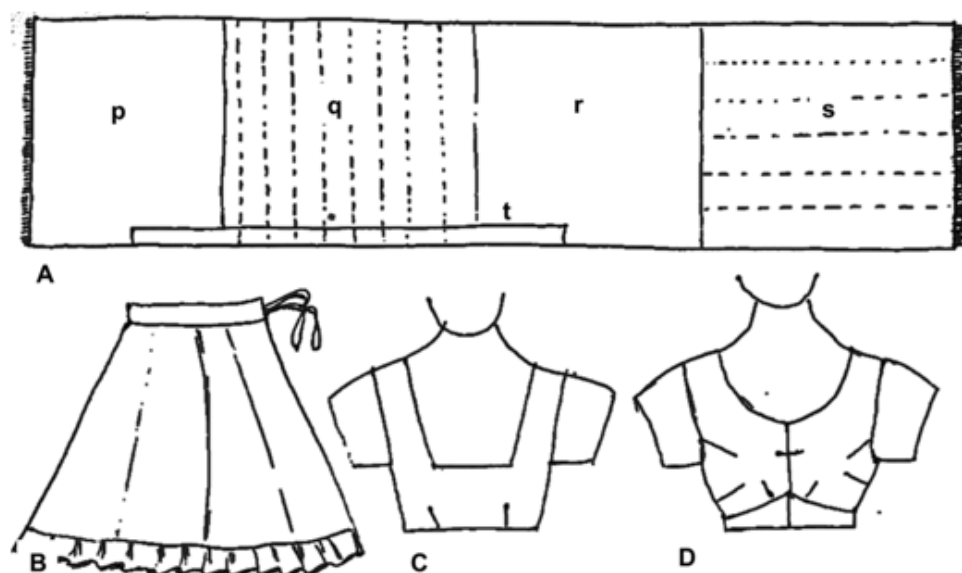

Figure 3. Parts of the ensemble 'sari.' A: Sari, B: Petticoat, C and D: Back and front sides of a bodice, p: inner layer of a sari, q: lower center-front pleats, r: front and rear cover, s: pleats of the pallu on the upper body, t: underlining.

However, some human physiology and comfort models divide the human body into multiple body parts (such as head, hand, chest etc., (Huizenga, et al., 2001; Zhang, et al., 2010) in order to accurately simulate skin and core temperatures and thermal comfort.

Most of these parts are normally covered with clothing insulation, which needs to be quantified in the simulation. Unfortunately, existing clothing insulation databases only characterize the clothing insulation for the whole body, and not for individual body parts. That means, every body part has the same clothing insulation level, even over the head and the hands.

With these aspects in mind, we conducted a climate chamber study on a sixteen-body segment female thermal manikin, draped in three different ensembles of saris (two

saris and four drapes). The present paper presents the insulation values for each body part, as well as for the whole body for these ensembles.

2 Methods

2.1 The material

The sari in its modern day *avatar* is a single rectangular piece of unstitched cloth: 1.15 – 1.25 m wide and 5 to 8.1 m (5.5 yards to 9 yards) long (Fig.3 A). The more ornate, freely hanging end of the sari is called as ‘pallu,’ (Fig 3: s, Fig. 4 G)



Figure 4. Indian sari ensemble draped in ‘nivi’ style on a human subject and the manikin with (A –C) pleated pallu and (D, E) un-pleated pallu. A: Front view; B: Rear view; C: Seated manikin; D: Un-pleated pallu covering one shoulder; E: Un-pleated pallu covering both the shoulders; G: Pallu; H: Pleats of the pallu on the upper body; J: Lower center front pleats









The draping style of sari varies with geographical area and the activity of the female, while there are more than a hundred known styles of draping. Sometimes the ‘pallu’ is used to cover one or both the upper arms and back (Fig. 4: D, E). Alternately, it can be pleated and pinned to the bodice on either of the shoulders (Fig. 4: A-C)

Table 1. Weights and material composition of the garments tested

Clothing	Weight (g)	Material
Bra	40	Shell: 100% Cotton: Trims: 100% Elastin
Panty	34.99	100% Cotton
Mauve cotton bodice	78	100% Cotton
Petticoat	205	100% Cotton
Silk yellow bodice	78	Shell: 100% Silk, Lining: 100% cotton
Silk yellow sari	450	100% Silk
Polyester green sari	665	50% Cotton 50% Polyester
Shawl	220	100% Acrylic

For this study we used the most popular ‘nivi’ style of draping along with its four sub-variations using two 5.75 m long saris. We draped the female manikin ‘Monica’ in two different saris. These are (1) a heavy weight poly-cotton handloom sari, and (2) a lightweight pure silk sari made in the Indian States of Karnataka and Tamilnadu respectively. In addition, we have also used an acrylic shawl from Uttar Pradesh. The weights and material composition of these garments are listed in Table. 1. The descriptions of sari and ways of draping are described in Table 2.

Table 2. Description of the ensembles tested.

Front/ rear views		Ensemble description	No.
		Sari pallu unpleated covering both arms	En1
	Summer/ monsoon	Sari pallu unpleated covering one arm	En2
		Sari pallu pleated both arms exposed	En3
		Sari pallu pleated covering one arm and back	En4
		Sari pallu pleated covering one arm and with shawl	En5
	Winter	Sari pallu pleated covering both arms and with shawl	En6
	Summer/ monsoon	Silk sari pallu pleated, both arms exposed	En7
		Silk sari pallu unpleated covering one arm	En8
		Silk sari pallu unpleated covering both arms	En9

2.2 Draping of a sari

Figure 5 shows the stepwise procedure of wearing a sari. In its modern style, the sari is draped in two layers from right to the left over a petticoat and a short tight fitting bodice. Five to eight flat pleats (each about 0.1 m wide) are clustered at the navel/centre-front using fingers, on the outer layer. These are inserted into the first layer of the sari, which is being tightly held by the petticoat. Sometimes safety pins are used to hold the pleats in position (Fig. 4).

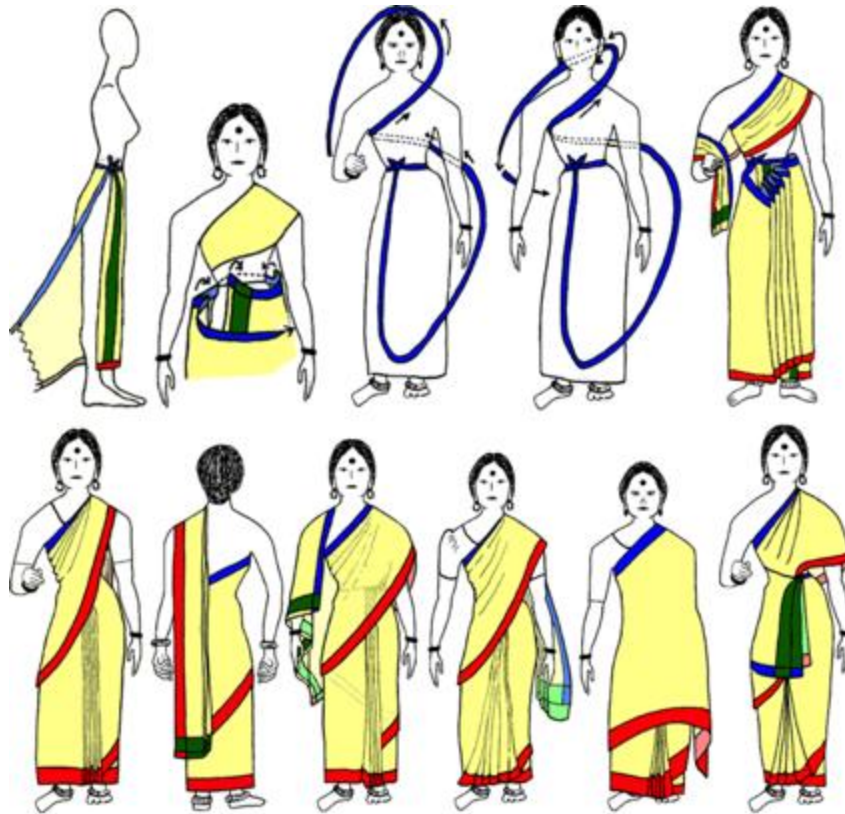

Figure 5. The steps of sari draping in 'nivi' style (Boulanger, 1997)

The pleats offer fullness at the ankle, and improve the wearer's mobility. Their number depends on the waist size of the wearer, desired length of the pallu and eventually the length of the sari. A long strip of cotton or polyester underlining (0.1 x 2.4 m) is often hemmed at the bottom selvage line of the sari (Fig. 3: t), where the pleats are formed, to add to the drape/ fall and fullness the garment.

2.3 The petticoat

A petticoat (Fig. 3B) is a stitched loose fitting conical shaped drawstring full skirt, usually in cotton/ polyester/ satin, worn around the waist. Most women wear a petticoat under a sari, although the sari can be draped without one. It adds fullness to the ensemble, and prevents the exposure of the silhouette of the legs, if the sari is thin/ transparent, while improving the walking and working convenience of the wearer. Some petticoats worn under saris made of sheer fabrics are heavily embellished at the hemline. We used a simple cotton petticoat without pleats at the bottom in this test.

2.4 The bodice or blouse

The bodice, or 'blouse' as it is called in India, is a body-hugging stitched single piece of garment (Fig. 3 C, D) covering the upper body, up to a few inches above the navel. The bodice's material, sleeve length and the size of the neck are matters of choice,

season and style. It can be very highly embellished at the back/ front and on the sleeves. Some women wear bodices up to the navel and with full sleeves for cultural and religious reasons. We used two deep and wide necked bodices with sleeves up to the middle of the upper arm in this study.

2.5 The shawl

A shawl is a rectangular piece of unstitched cloth usually two to two and half meters long. Both men and women usually drape shawls over the dress/ sari in winters. Men’s shawls are slightly bigger in size. Shawls are made of a wide variety of materials ranging from pure wool, acrylic, polyester, chiffon, cotton and silk. The choice of the material depends mainly on the season, style and wearers’ taste. In this study we used a medium-sized acrylic women’s shawl (2.05 m x 0.72 m), usually used in winters. The ensembles EN5 and EN6 as shown in Table 2 feature the shawl used in this test.

2.6 The ensembles tested

The manikin was draped in ‘nivi’ style. Three sari ensembles were tested and about four ways of drapes are included. All together, we tested nine combinations of ensemble/drapes commonly observed in office buildings in both winter and summer. These are named EN1 to EN9 and are listed in Table 2.

2.7 The experimental setup



Figure 6. (Left to right) The test conditions of the climate chamber showing the data-logger setup; manikin with petticoat, panty, bra and bodice; a rear view of a sari and bodice on a human subject; manikin in a sari ensemble

Table 3. Experimental test conditions

Ambient temp. (°C)	Manikin skin temp. (°C)	RH (%)	Air velocity (m/s)	Posture	Chair
20.09 ±0.29	34	51.18	0.1	Seated on a chair	Mesh arm Chair

We conducted the tests in the climate chamber measuring 5.5m x 5.5m x 2.5 m, with windows on the southern and western sides, at University of California Berkeley (Fig. 6). Its windows are shaded by fixed external shading devices. A dedicated system controls the temperature of these windows. The levels of temperature, humidity, ventilation and lighting in the chamber can be controlled precisely. It has accuracies of 0.5 °C and 3% for temperature and humidity respectively. About eight floor grill

diffusers control the temperature and ventilate the room air, while the air is exhausted through a ceiling return grill. Table 3 features the experimental conditions.

The air temperature in the chamber was maintained at 20 °C. The data loggers (HOBO- U12-03) measured the wall temperature and ambient temperatures at 0.1 m, 0.6 m and 1.1 m heights and the relative humidity at the center of the chamber (Fig.7). The data logger has the measurement accuracy of ± 0.35 K at 0 ~ 50 °C range of temperatures and ± 2.5 % relative humidity (RH) at 10- 90% range of RH. The ambient temperature was also measured using a high precision mercury thermometer.

We tested with a Danish adult female manikin in the climate chamber in September 2013 (Fig. 6). The manikin’s 16-segment body parts can be controlled and measured independently (Fig.7). Its body parts and their surface areas are listed in Table 4.

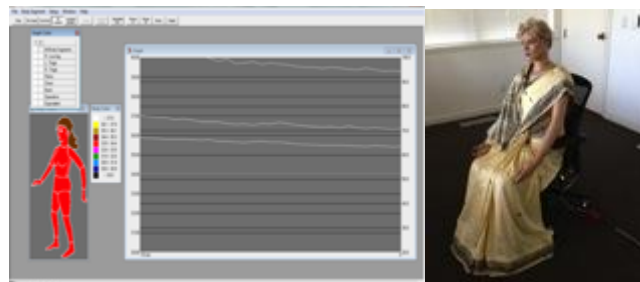

Figure 7. The manikin control screen (left), climate chamber and thermal manikin ‘Monica,’ in a sari

Table 4. Body segments and respective areas of the manikin

SNo.	Name of Part	Area (m ²)
1	Left Foot	0.043
2	Right Foot	0.041
3	Left Leg	0.089
4	Right Leg	0.089
5	Left Thigh	0.160
6	Right Thigh	0.165
7	Pelvis	0.182
8	Head	0.100
9	Left Hand	0.038
10	Right Hand	0.037
11	Left Arm	0.052
12	Right Arm	0.052
13	Left Shoulder	0.073
14	Right Shoulder	0.073
15	Chest	0.144
16	Back	0.133
Total		1.471

We set the skin temperature of the manikin to 34 °C, and followed the protocols of ASTM (ASTM-F1291-10, n.d.), and ISO (ISO:9920, 2004) for testing with the manikin. The ISO uses individual pieces of garments for testing and the clothing insulation of the ensemble is obtained through the summation of individual pieces of the ensemble. However, we tested the sari as a whole ensemble, as the individual pieces of garments are seldom used separately (Fig. 7).

We seated the manikin in a mesh armchair and tested all the ensembles for a minimum of two hours or longer, until the manikin is stabilized. When stable, the heat

loss measurements were averaged over a 10 min period. The insulation level of the mesh chair was also measured. We subtracted the insulation of the chair and nude manikin from the total insulation obtained with the any ensemble for all the body parts, thus eliminating the effect of the chair and nude insulations.

3 Analysis of test data and evaluation of clothing insulation

Nude condition, and the one with cotton undergarments are also tested. We estimated the total insulation using the Eq (1), given the manikin skin temperatures ($T_{s,i}$) and heat fluxes ($Q_{t,i}$).

$$I_{t,i} = (T_{s,i} - T_a) / (0.155 * Q_{t,i}) \quad [1]$$

Where, T_a is the ambient air temperature, I_{cl} = Clothing Insulation (clo) and 1 clo = 0.155 m² °C/W. The intrinsic insulation of the clothing itself was calculated by Equation (2):

$$I_{cl,i} = I_{t,i} - I_a / f_{cl} = I_{t,i} - I_a / (1 + 0.3 I_{cl,i}) \quad [2]$$

The thermal resistance of the nude body sitting on the mesh chair was measured as 0.78 clo during this experiment.

The insulation values for each of 16 body parts and the whole-body are tabulated in Table 5. Values for left and right extremities are averaged and combined.

The winter ensembles tested had 1.11 – 1.39 clo as the whole-body clothing insulation, while the summer and monsoon ensembles tested ranged from 0.62 – 0.96 clo.

Table 5. Clothing insulation values of the ensembles tested (BP: Bra+panty, BSAC: Body surface area covered (%)).

Clothing ensemble	BSAC (%)	Whole-body	Head	Chest	Back	Shoulder_L	Shoulder_R	Lower arm_L	Lower arm_R	Hand	Pelvis	Thigh	Lower leg	Foot
Mesh Chair		0.03	0	0.05	0.14	0.01	0.03	0.01	0.03	0	0.02	0.11	0	0
BP	20	0.03	0	0.23	0	0	0	0.01	0.02	0	0.19	0.02	0	0
En1	81	0.96	0	1.9	1.23	1.58	1.07	0.56	0.4	0	2.01	0.75	0.98	0.33
En2	73	0.74	0	1.06	0.29	1.14	0.22	0.55	0.13	0	2.05	0.75	1.08	0.26
En3	65	0.65	0	1.5	0.45	0.73	0.17	0	0	0	1.8	1.91	1.12	0.41
En4	73	0.81	0	1.83	1.21	0.78	0.84	0	0.51	0	1.47	1.72	1.11	0.38
En5	81	1.11	0	2.71	1.94	1.75	1.29	0.84	0.69	0	1.99	1.92	1.09	0.38
En6	81	1.39	0	3.98	2.35	2.76	1.96	1.79	1.05	0	2.35	2.24	1.18	0.41
En7	65	0.62	0	1.32	0.51	0.85	0.25	0	0	0	1.58	1.62	0.95	0.25
En8	73	0.87	0	1.76	1.31	0.78	1.18	0	0.47	0	1.88	1.99	0.99	0.31
En9	81	0.94	0	1.58	1.35	1.15	1.08	0.57	0.49	0	1.83	1.84	0.97	0.27

4 Discussion and comparison with others' results

The body surface area covered (BSAC) by a garment relates to the clothing insulation value of an ensemble. In this study we noted that the BSAC varied from 65 % to 81%, while the whole-body insulation varied from 0.65 clo to 1.11 clo for summer ensemble (Table 5). The change in BSAC *vis a vis* the clothing insulation is obtained primarily by draping the sari around the upper body differently. This changed the exposed body surface area of the manikin.

The results show that the sari is a versatile clothing ensemble with the possibility of a wide range of comfort conditions and clothing insulation, for the same pieces of garments used. Clothing insulation was increased by as much as 35% just by changing the drape on the upper body alone using the same set of garments. For example, for En1 to En3 we used the same pieces of garments (Poly-cotton sari, cotton bodice and a cotton petticoat). By manipulating the pallu around the torso and arms alone, we increased the BSAC from 65% to 81%. It meant that the clothing insulation increased from 0.65 to 0.96 clo. Similar variation in clo value was noted between ensembles En7 – En9, by as much as 0.32 clo.

The summer and monsoon clothing insulation values matched closely with the clothing insulation of sari as reported by Mitsuzawa and Tanabe and Havenith et al. (Mitsuzawa & Tanabe, 2001; Havenith, et al., 2014). Mitsuzawa and Tanabe reported the basic clothing insulation for cotton sari with cotton petticoat and bodice as 0.65 clo. Havenith et al. reported a basic clothing insulation of 0.74 clo for polyester sari with cotton bodice and cotton petticoat and 0.96 clo for the same ensemble worn along with an acetate shirt and a cotton towel worn as a head cover.

Interestingly the summer clothing of the Middle Eastern women wearing summer *daraa* (a full-sleeved loose fitting long gown), *shiala* (fully covering long head scarf), bra, panty and sandals with a clothing insulation of 1.20 clo (Al-ajmi, et al., 2008) was noted to be a near equivalent to the winter ensembles tested in this study. Lee et al. noted Western summer ensembles (e.g.: bra, panty, turtleneck blouse, skirt and socks with formal shoes) offering similar clothing insulation (0.65 clo) (Lee, et al., 2013), to that of the light Indian summer ensembles as found in this study. The Middle eastern ensembles offered higher clothing insulation, perhaps as the *daraa* covered the arms and legs fully while, the *shiala* covered the neck and head completely, leaving only the face exposed.

Table 6. Clothing insulation values of the ensembles tested and as compared to Hanada et al. (1983)

Ensemble	Weight* (g)	Clo Value measured	Clo (Hanada)	Havenith (clo)
En1	1022.99	0.96	1.03	
En2	1022.99	0.74	1.03	
En3	1022.99	0.65	1.03	0.74 ⁺
En4	1022.99	0.81	1.03	
En5	1242.99	1.11	1.25	0.96 ⁺⁺
En6	1242.99	1.39	1.25	
En7	807.99	0.62	0.81	
En8	807.99	0.87	0.81	
En9	807.99	0.94	0.81	

(*: includes the weight of the under garments) (⁺ a near equivalent drape without lower center pleats; ⁺⁺ a near equivalent drape of the sari along with an acetate shirt and a cotton towel head cover, used by factory workers)

Field study evidence points to further possibility of change in the BSAC and thus the clo value of a sari ensemble. Indraganti (Indraganti, 2010), noted in a residential building study in India that the subjects have modified BSAC by raising the sari pleats up to the calves, while at heavy work in warm environments. This adaptability of the sari could have further reduced the clo value, for the same pieces of garments. However, due to logistic constraints we could not test the variations with the sari ensemble in the lower portion of the body.

Some other researchers found a linear relationship between the clothing insulation of an ensemble and its weight (Hanada, et al., 1983) as,

$$I_{cl} = 0.00103 W - 0.0253 \quad [3]$$

where, I_{cl} = Clothing Insulation (clo) and W = weight of the ensemble in grams (g).

We compared our results with those obtained through the above relationship and noticed interesting observations. While most of our clothing insulation values obtained through the laboratory study matched closely with Hanada et al., it overestimated the clothing value when the BSAC was low (Table 6.). This observation renders support to the evidence that the sari is a versatile ensemble with a wide range of clothing insulation values within a given set of pieces of garments.

5 Conclusions

We measured and calculated the clothing insulation for the sixteen body parts for nine typical ensembles using two saris draped in the most common 'nivi' style. The values are useful for multi-segmented models of thermo-physiology and comfort. Unlike the western outfits, the sari was found to be a unique ensemble offering a range of clothing insulation, rather than a single value for a given set of garments of the ensemble depending on the drape. We noted the clothing insulation varying by about 35% due to the changes in drape on the upper body alone.

The winter ensembles had a clothing insulation of 1.11 – 1.39 clo, while the summer and monsoon ensembles provided 0.62 – 0.96 clo as clothing insulation. These values obtained using standard protocols of ISO: 9920 can be used in the design of indoor environments in the sub-continent and advanced comfort models which need clothing insulation at segmentation level.

It is important that the designers should consider a broader range of clothing among a building's female occupants. More pertinently, in multi-cultural environments coupled with adaptive behaviour, questions on dress habits may be included in the thermal questionnaires and the options on various drapes in the clothing checklists during the thermal comfort surveys. Information on various drapes and materials could be built into the future version of the standard. The findings of this research are more than a correction of clo value of saris.

Acknowledgements

For the manikin testing and analysis, we used the climate chamber facilities at the Centre for the Built Environment, University of California Berkeley. The test facility is made available through the Fulbright Grant and the support of HAE, R&D Center, LG Electronics, South Korea. Padma Indraganti of Los Angeles, USA provided us the garments. The authors appreciate their financial and logistic support.

References

- Al-ajmi, F. F., Loveday, D. L., Bedwell, K. H. & Havenith, G., 2008. Thermal insulation and clothing area factors of typical Arabian Gulf clothing ensembles for males and females: Measurements using thermal manikins. *Applied Ergonomics*, p. 39 (2008) 407–414.
- ASHRAE, 2010. *ANSI/ ASHRAE Standard 55-2010, Thermal environmental conditions for human occupancy*, Atlanta: s.n.
- ASTM-F1291-10, n.d. *Standard Test Method for Measuring the Thermal Insulation of Clothing Using a Heated Manikin*, s.l.: s.n.

- BIS, 2005. *National Building Code 2005*. s.l.:Bureau of Indian Standards.
- Boulanger, C., 1997. *Saris: An Illustrated Guide to the Indian Art of Draping*. s.l.:Chantal Boulanger Publishing, 78 Hammersmith Bridge Road, London W6 9DB Great Britan.
- Gagge, F., Fobelets, A. & Berglund, L., 1986. A standard predictive index of human response to the thermal environment. *ASHRAE Transactions*, 86(2), pp. 709-731. .
- Hanada, K., Mihira, K. & Sato, Y., 1983. Studies on the thermal resistance of men's underwear. *Journal of Japan Research Association for Textile End-Users*, 24(8), pp. 363-9.
- Havenith, G. et al., 2014. *Extension of the Clothing Insulation Database for Standard 55 and ISO 7730 to provide data for Non-Western Clothing Ensembles, including data on the effect of posture and air movement on that insulation.*, s.l.: s.n.
- Havenith, G., Holmer, I. & Parsons, K., 2002. Personal factors in thermal comfort assessment:clothing properties and metabolic heat production. *Energy and Buildings*, pp. 34 (2002) 581 - 591.
- Huizenga, C., Zhang, H. & Arens, E., 2001. A Model of human physiology and comfort for assessing complex thermal environments. *Building and Environment*, Volume 36, pp. 691 - 699.
- Indraganti, M., 2010. Thermal comfort in naturally ventilated apartments in summer: Findings from a field study in Hyderabad, India. *Applied Energy*, 87(3), pp. 866-883.
- Indraganti, M., Ooka, R. & Rijal, H. B., 2013. Field investigation of comfort temperature in Indian office buildings: a case of Chennai and Hyderabad. *Building and Environment*, 65(7), pp. 195-214.
- Indraganti, M., Ooka, R., Rijal, H. B. & Brager, G. S., 2014. Adaptive model of thermal comfort for offices in hot and humid climates of India. *Building and Environment*, Volume 74, pp. 39-53.
- ISO:9920, 2004. *Ergonomics of the thermal environment — Estimation of the thermal insulation and evaporative resistance of a clothing ensemble*, s.l.: International Standards Organization.
- Lee, J., Zhang, H. & Arens, E., 2013. *Typical clothing ensemble insulation levels for 16 body parts*. Prague, Czech Republic, s.n.
- McCullough, E. & Jones, B., 1983. *Measuring and estimating the clothing area factor*, Manhattan KS: s.n.
- Mitsuzawa, S. & Tanabe, S., 2001. *Effect of air movement on thermal comfort under hot and humid conditions while wearing traditional clothing*. Windsor, s.n., pp. 491-500.
- Zhang, H., Arens, E., Huizenga, C. & Han, T., 2010. Thermal sensation and comfort models for non-uniform and transient environments, part III: Whole-body sensation and comfort. *Building and Environment*, 45(2), pp. 399-410.

Neuron fire rates simulations of cold thermal sensations validated by measurements

Derek Vissers, Wim Zeiler, Gert Boxem, Michal Vezely, Jacob Verhaart

University of Technology Eindhoven,

Abstract

Thermal comfort, determined by the influence of the indoor environmental parameters on thermal sensation, is regarded as an important indicator of human wellbeing and health. Neurophysiological mechanisms are responsible for thermal sensation. Models of thermal sensation could be very useful in design of new high performance buildings. Humans do not sense temperature directly. Temperature information is coded into the firing rate of temperature sensitive neurons (thermoreceptors). Human skin contains two types of thermoreceptors “cold” or “warm” sensitive. Kingma developed a new model for thermal sensation based on the neurophysiology of thermal reception and integration through neural pathways. In a proof-of-principle experiment we applied the model of Kingma on an personalized hand-heating system using two incandescent reflector heating lamps. Using the model by Kingma and the results of the experiments, the neuron discharge rate was simulated to see if it captured the dynamics of thermal sensation.

Keywords: neuron fire rates, thermal sensation, comfort

1 Introduction

In quest for net zero energy buildings the research is focussing on the reduction of energy use as much as possible. This leads to situations that the comfort of occupants and even on the long run their health may be endangered. Therefore it is essential to start the building design process from the human perspective and to think about the goal of most of the energy use within the built environment: thermal comfort. On the other hand there is the relation between productivity of the occupants and their perceived comfort [Akimoto et al 2010]. To optimize thermal comfort and minimize the necessary energy for conditioning different personalized conditioning systems were proposed and studied, including personalized ventilation, combination of personalized ventilation with local convective and radiant heating or personal environmental module [Demeter & Wichman 1993]. These systems not only have a potential positive impact on thermal comfort and indoor air quality, but also with a proper control strategy for energy reductions [Schiavon & Melikov 2009, Schiavon et al. 2010, Zhang et al. 2010]. After test with some concepts for personalized conditioning [Filippini 2009, Vissers 2012] we concluded out that it very important to include the perceived individual comfort of the occupants within the control loop, as well as to improve the effectiveness of the applied conditioning devices, in our case heaters. Still it is important to rethink the accepted comfort wisdom [de Dear 2011]. This could be the physiological concept of alliesthesia [Parkinson et al. 2012] focussing on thermal pleasure, or as we did in our

research provide the required thermal comfort level by looking at comfort from a new more fundamental (neuro) physiological perspective [Kingma et al. 2012]: thermoregulation.

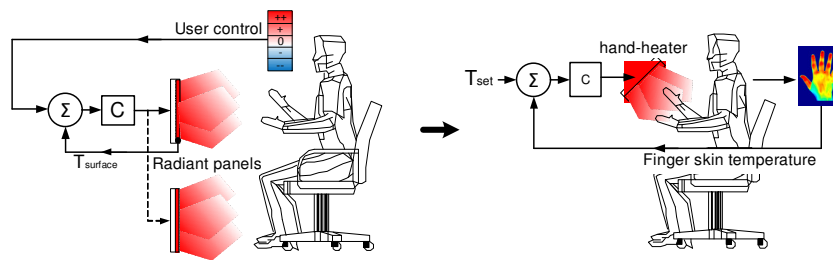

Figure 1. First concept for individual heating [Filippini 2009] and second improved concept [Vissers 2012]

2 Thermoregulation

According to Arens and Zhang [2006] thermoregulation is the ability of an organism to keep its body temperature within certain boundaries, under different surrounding temperatures. The normal core temperature of the human being is about 37°C and varies with a daily pattern in between 36-38°C. By various physiological mechanisms (i.e. the autonomic thermoregulation), this core temperature is held between a narrow range. The human skin is the major organ that controls heat and moisture flow to and from the surrounding environment [Arens and Zhang, 2006]. Skin adaptation to temperature is an aspect of human physiology similar to other sensory adaptations, e.g. eyes to darkness, tongue to taste, and ears to noise [Zhang, 2003]. Using noise as an example: most of the time human beings are unaware of the noise level in the environment; only when this level exceeds a certain threshold human beings become aware of it. The same is applicable for the reference set-point skin temperature, at which no warm or cold sensation is felt. When a local area of the skin has adapted to a temperature, the skin temperature can fluctuate within a range of temperatures without producing any temperature sensation [Kenshalo, 1970]. In this range the set point for thermal sensation adapts to the current skin temperature. The results of Kenshalo's study are presented in Figure 2 A. It shows the adapting temperature (horizontal axis) and thermal stimulus (vertical axis), and the perception of a change in skin temperature (dotted line). There is a neutral zone (31-36°C) in which the skin temperature can be changed without influencing thermal sensation. Above and below the neutral zone, a persisting warm or cool sensation was felt. However this is only valid for small changes in skin temperature. Based on these results, an adaptation model was proposed by Zhang, see Fig. 2-B [Zhang, 2003]. This theory is important for the proposed control strategy, because it indicates the possibility to detect a transition in skin temperature before the user perceives a persisting cool or warm thermal sensation.

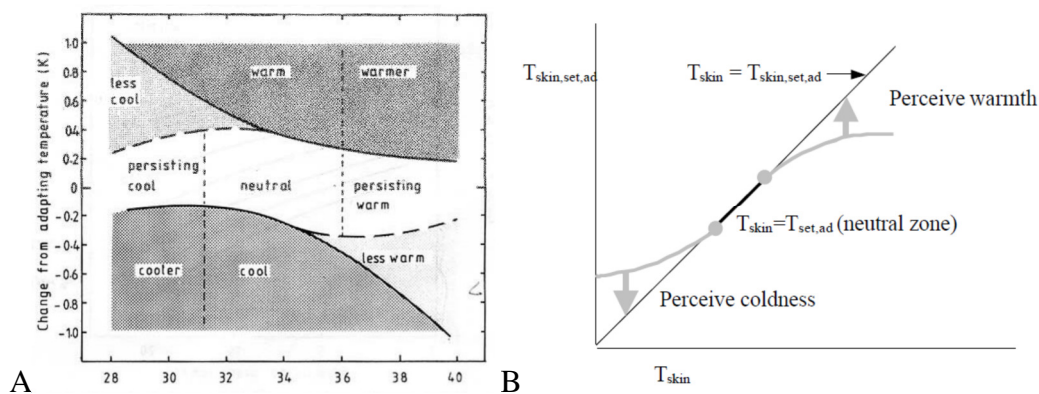

Figure 2 A) Just noticeable changes in forearm skin temperature as a function of the adapting temperature. Thresholds for a change in sensation shown by the dotted curve [Zhang, 2003]. Original figure adapted from

Kenshalo [1970]. B) Adaptation model as proposed by Zhang: skin temperature versus the adapting set-point temperature [Zhang, 2003].

Thermoregulation itself consists of three major components namely: 1) thermal reception by temperature sensitive neurons, 2) integration through neural pathways, and 3) the effective thermoregulatory response [Kingma, 2011]. The effective thermoregulatory response consists of heat production, heat loss and heat transport. Accurate models of thermal sensation might be useful for the comfort process control and design of high performance buildings [Kinga et al. 2011].

3 Thermo-physiological model

The major components of the human thermoregulatory control system are the thermoreceptors (sensors), thermo-regulatory effectors (actuators), and the central nervous system (the controller). For the temperature control of the human body thermoreception is crucial. Thermoreception can be defined as “a process where at different levels heat energy is perceived by living organisms” [Hensel, 1981]. The main issue is that humans do not sense temperature directly. Temperature information is coded into the firing rate of temperature sensitive neurons (thermoreceptors) [Kingma, 2011]. These neurons are found all over the body. Via the sympathetic nerve system, the temperature information is passed to the hypothalamus in the brains. In this part of the brains the autonomic thermoregulation is activated when the temperature becomes lower or higher than the desired reference temperature [Stolwijk 1971].

The human skin contains two types of thermoreceptors, namely “cold” and “warm” sensitive receptors. The skin consists of two different layers, the epidermis and the dermis. A cross-sectional view of the skin is shown in Fig. 3. The cold sensitive receptors are mostly located in the epidermis, and the warm sensitive receptors are located in the dermis layer, direct below the epidermis [Arens et al., 2006].

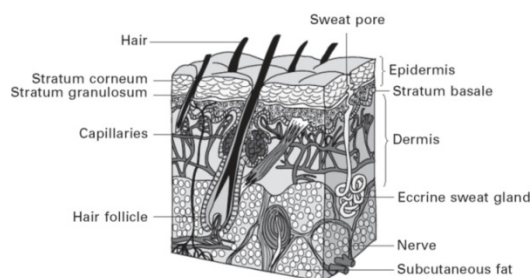

Figure 3. Cross-sectional view of the human skin [Arens et al., 2006].

Each receptor is activated in a specific range. Zotterman reported thermoreceptor fire rates for steady-state temperature experiments on cat tongue [Zotterman, 1953]. The maximum steady state discharge rate for cold sensitive receptors lies around 25°C (11 imp/sec) and for warm sensitive receptors around 38°C (4 imp/sec), see Fig. 4-A. Most of the thermoreceptor data is derived from experiments with anesthetized animals. However in literature the thermoreceptor data differs considerably. Experiments by Hensel and Kenshalo on cat nose showed totally different results [Hensel et al., 1969]. In addition, the static profile as found in the textbook of medical physiology [Guyton and Hall, 2000] differs from the data as found by Zotterman (Fig. 4-B). Guyton reported that there are three types of thermoreceptors, namely cold receptors, warm receptors and pain receptors. The maximum steady-state discharge rate for the cold sensitive receptors lies at 25°C (7 imp/sec) and for the warm sensitive receptors at 44°C (10 imp/sec) [Guyton and Hall, 2000].

In addition to the steady state discharge rate, time dependent changes in skin temperature also influence the discharge rate. When a receptor is subjected to an abrupt change in temperature, it is strongly stimulated at first, sending impulses at a high frequency (Fig. 4-C). For this reason a person feels much colder or warmer when the temperature of the skin is actively falling or rising than when the temperature remains at the same level. The overreaction during transient exposures is called ‘overshoot’ [Arens et al., 2006].

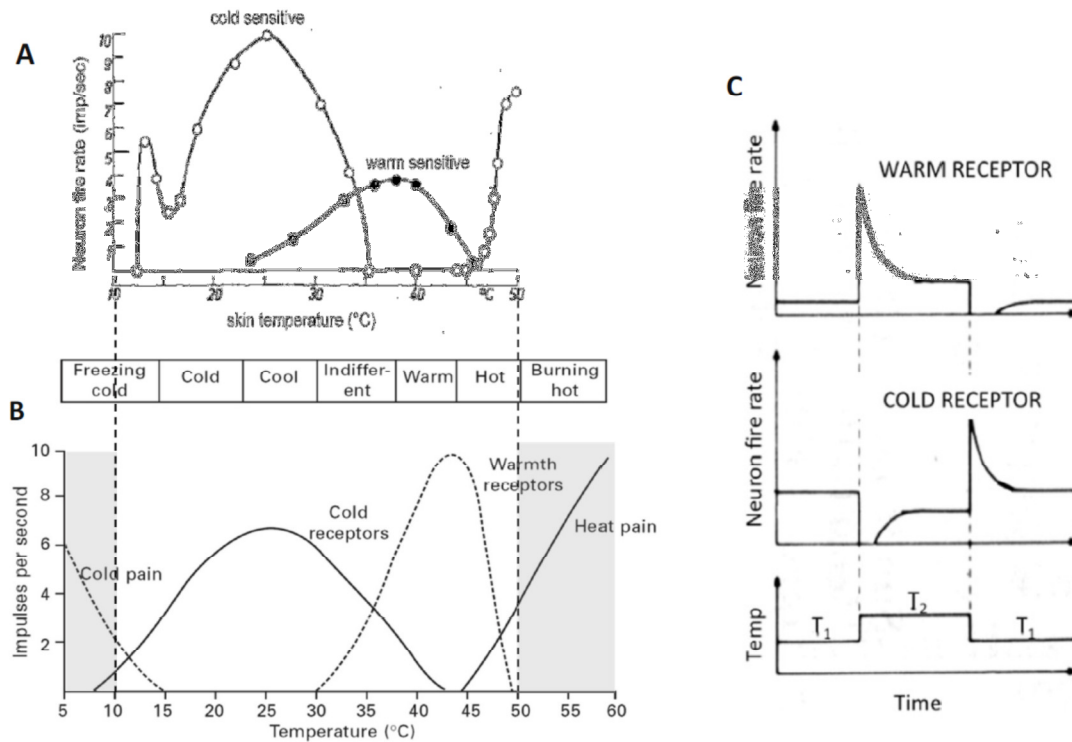

Figure 4 A) Steady-state neuron fire rate versus skin temperature for cold- and warm sensitive neurons for data obtained by [Zotterman, 1953]. B) Steady-state neuron fire rate for data obtained by [Guyton, 1981]. Clearly visible is the difference in neuron fire rates, in particular for the warm sensitive neurons, between A and B. C) Dynamic neuron fire rate of the temperature sensitive neurons [Kingma, 2011]. Original adapted from [Hensel, 1982].

Skin blood flow (SBF) is a dominant factor in human thermoregulation during mild thermal challenges [Kingma, 2011]. Although, various numerical models of SBF regulation exist none explicitly incorporates the neurophysiology of thermal reception. Boris Kingma tested a new SBF model that is in line with experimental data on thermal reception and the neurophysiological pathways involved in thermoregulatory SBF control. Additionally, he used a numerical thermoregulation model as a platform to test the function of the neurophysiological SBF model for skin temperature simulation [Kingma, 2011]. The prediction-error of the SBF-model was quantified and validated by him [Kingma, 2011] by determining mean-squared-residual (MSR) between simulations and experimental measurement data consisted of SBF (abdomen, ventral forearm, dorsal and ventral hand), core and skin temperature recordings of 12 young males during two transient thermal situations. Kingma [2011] found that the neurophysiological model predicted SBF with reasonable accuracy ($MSR < 0.01$).

Kingma et al. [2014] developed a neurophysiological basis for control functions in numerical thermoregulation models which creates synergy between physiology and mathematical modelling. Their study shows that thermal reception and neurophysiological pathways involved in thermoregulatory SBF control can be captured in a mathematical model, and (2) human thermoregulation models can be equipped with SBF control functions that

are based on neurophysiology without loss of performance. The neurophysiological model is based on an underlying physiology than and is therefore more suited for thermoregulated comfort process control. To test the approach a simulation was made with the simulation model developed by Kingma and based on the results of testing our personalized conditioning system [Visser 2012].

4 Experimental set-up

The experimental test room in which the measurement set-up was situated is shown in Fig. 5 A. The walls of the test room ($V=82\text{m}^3$) are surrounded by a controlled indoor environment with the exception of the west-facing external wall. This external wall contains one window (1.7x1.7m). The internal walls consist of hard wood, and the concrete floor is covered with carpet. In order to prevent a major influence of the radiant temperature of the window on the occupant, the desk was placed towards the center of the room. The position of the occupant relative to the walls is indicated in Fig. 5 B. The room air temperature was controlled by cool or warm air provided by respectively the ventilation system (rate= 2h^{-1}) or auxiliary heaters. Within most of the experiments, the external air temperature was $<5^\circ\text{C}$, thus no cooling was required in order to achieve the desired set-point room temperature. The auxiliary heater (i.e. radiator, 2kW) was placed below the window. The room air temperature was measured at different positions and height (0.1, 0.6 and 1.1m) in the test room. The surface temperatures of the walls, the window, ceiling and floor were measured for the calculation of the mean radiant temperature at the position of the occupant.

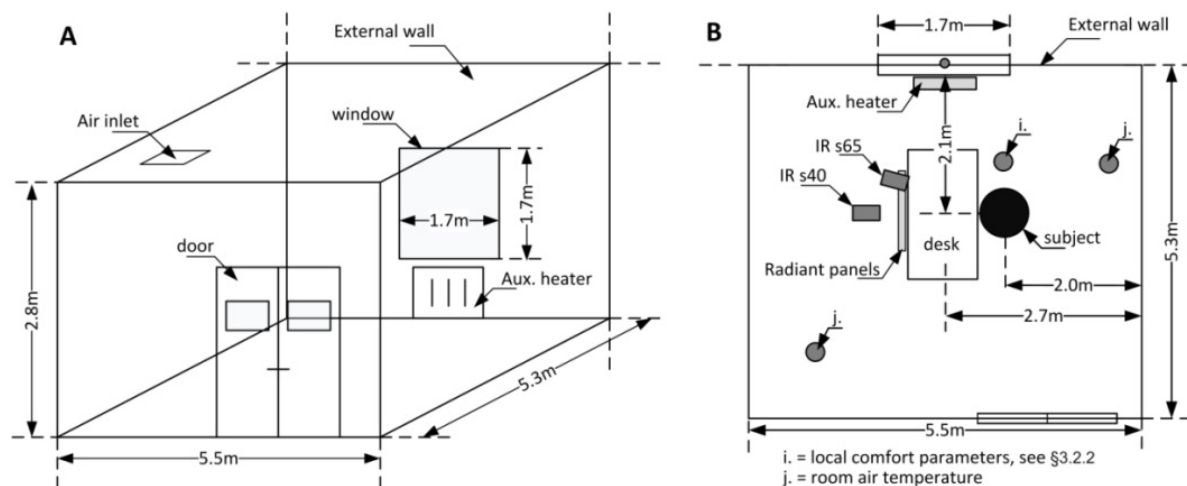

Figure 5 (A) 3D sketch of the test-room, and (B) position of the desk and occupant relative to the internal- and external walls.

To maintain the upper-extremity skin temperature at a neutral or higher thermal state in mild cold conditions a heating system was used which can transfer the radiation energy concentrated to the hand with a good view factor. This heating system consists of two incandescent reflector heating lamps (Philips R125 IR250) focusing on both the hands. About 90% of the energy is transmitted as infrared radiation. At maximum temperature the heating lamps emit mostly in the IR-A and IR-B wavelengths. A dimmer was used to vary the radiant heating intensity. The heating system was controlled by using subject's finger skin temperature (obtained by IR thermography) as control parameter. A sketch of the set-up and control scheme is shown in Figure 6.

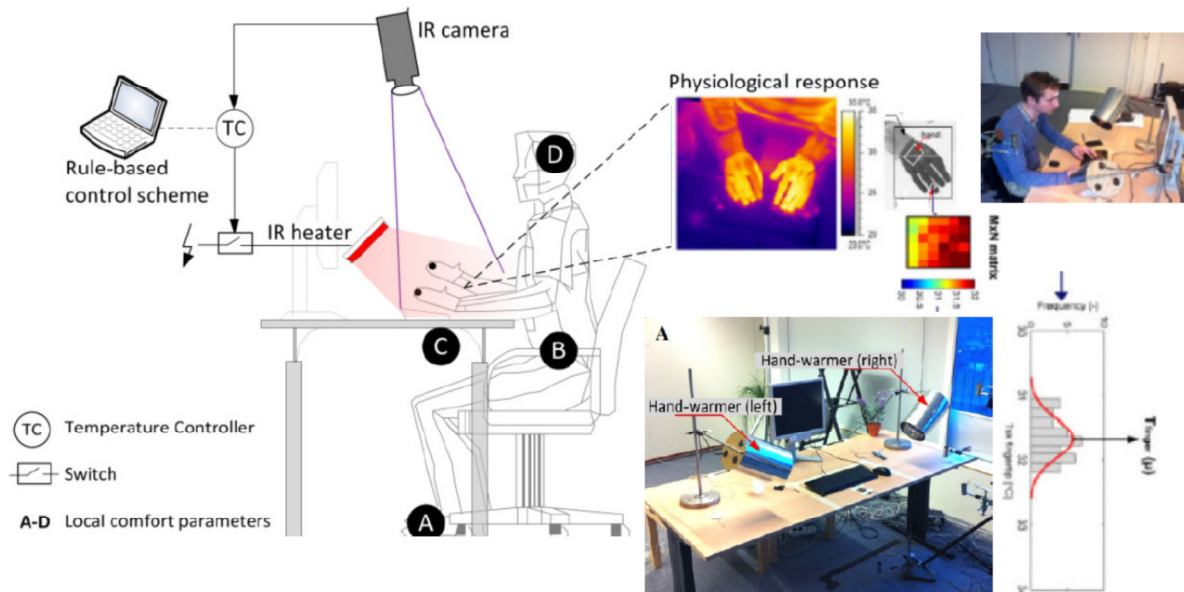

Figure 6. Local heating controlled by subject's upper-extremity skin temperature real-time control signal obtained from IR measurement.

The infrared measurement data was real-time used as control signal for regulation of the hand-heater. An MxN matrix skin surface area was selected at the 3rd finger of the left hand of the subject. An example is presented in Fig. 6, where skin temperatures are shown in a histogram along with the normal density function. The mean local skin temperature (μ) was used as the controlled variable. To avoid large fluctuations in the control signal the moving average signal (over 120s) was used. This resulted in a more smooth controlled signal profile.

The time schedule applied during the experiments is shown in Fig. 7. During the sessions, the subjects performed office tasks on their own laptop. The metabolic heat production was assessed 1.2 met ($1\text{met}=58\text{Wm}^{-2}$). A thermal acclimatization time of 20 minutes was applied to ensure the subject's upper-extremity skin temperature was in the neutral zone at the start of the session. Thereafter skin temperature sensors were attached. The total duration of the experiment was 3.5h. The time differs from the first series of experiments, so that the bandwidth can be tested several times per session. The subjects wore office clothing of 0.82clo.

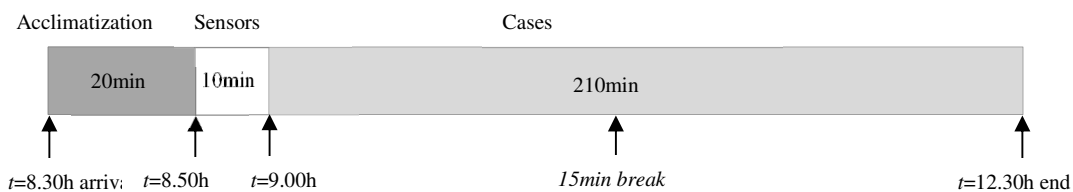

Figure 7. Time schedule applied during the experiments.

In order to investigate whether the proposed control algorithm is able to respond to user thermal preferences a questionnaire was applied. Thermal preferences were asked every 10 minutes during the entire session. The user was able to indicate if a warmer, neither warmer nor cooler, or a cooler environment was preferred. In addition, local- and overall thermal sensation, and thermal acceptability were assessed. The ASHRAE standard 7-point thermal sensation scale has been applied. These subjective responses were collected and correlated to the measurement results.

5 Results of measurements and simulation based on thermoreception

One of the latest developments are the use of a thermophysiological model in the built environment to predict thermal sensation [Schellen et al. 2013], which even allows to predict the effect of individual characteristics on the mathematical model of human thermoregulation [van Marken Lichtenbelt et al. 2004 & 2007]. Human do not sense temperature directly: Temperature information is coded into the firing rate of temperature sensitive neurons. Kingma et al. [2010] developed a model based on neurophysiology, which can capture the dynamic behaviour of thermal sensation during transients. This model uses thermoreceptor data as reported by [Zotterman, 1953]. For a detailed description of the model Kingma see his PhD thesis [Kingma, 2011]. Using this model for the measured skin temperatures, the neuron discharge rate was simulated, see Fig. 8.

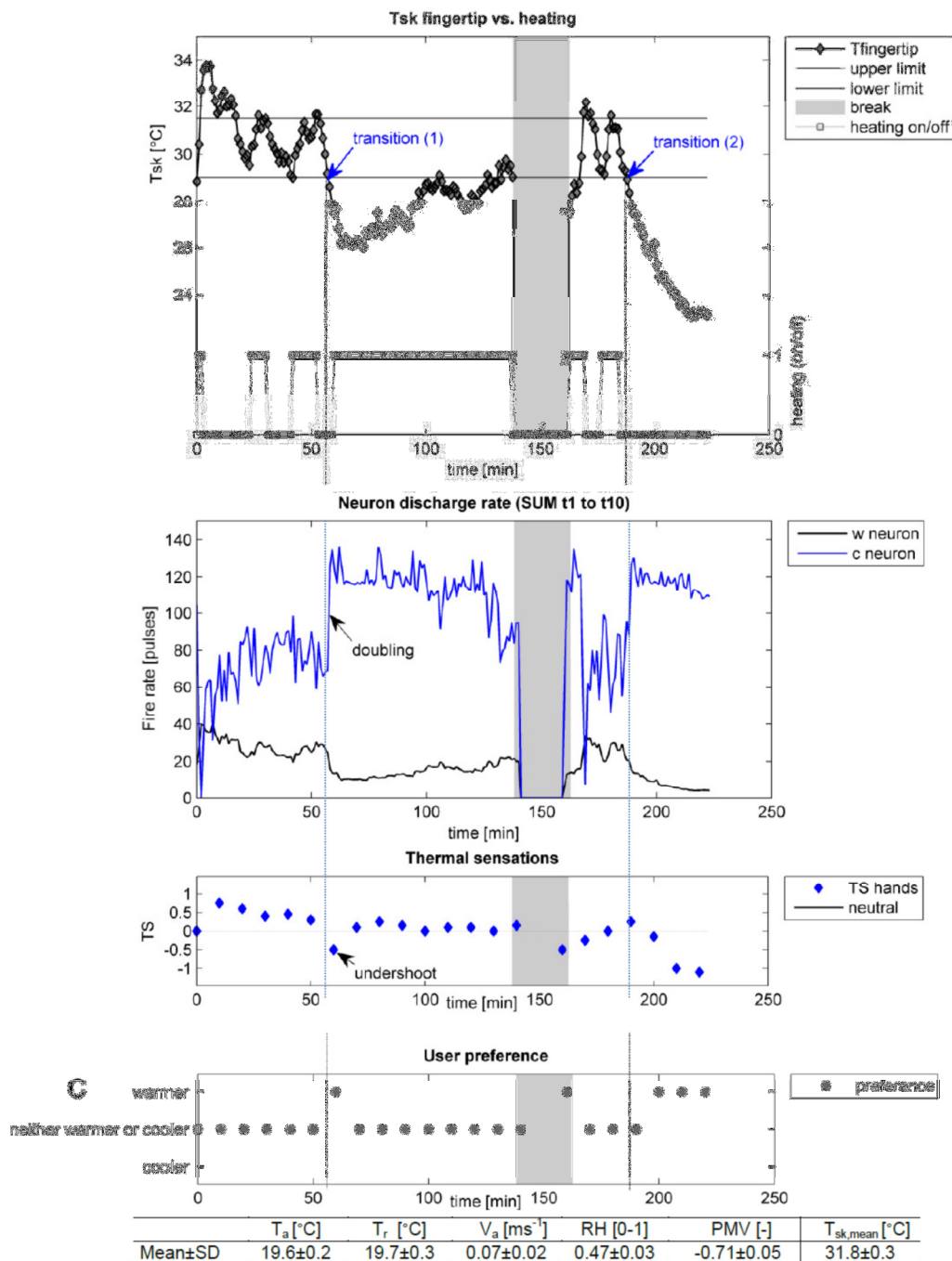

Figure 8. The dynamics of thermal sensation. (A) Neuron discharge rate of the cold and warm sensitive neurons for the measurement results of 10-02-2012, (B) Local thermal sensations of the hands.

The sum of the 1st 10seconds of the neuron fire rate of the warm and cold-sensitive neurons are presented in Figure 8, part A. The sum is highly sensitive for quick changes in local skin temperature and may explain the dynamic character of thermal sensation. The thermal sensation votes are shown in part B. The significant decrease in skin temperature after 55min (i.e. transition 1, Figure 10) is clearly reflected by the strong increase in the neuron fire rate of the cold-sensitive neurons. As a result, the local thermal sensation of the hands strongly decreased, from 0.3 (t=40min) to -0.5 (t=50min), and then increased to 0.1 (t=60min): a typical 'undershoot' in thermal sensation.

6 Discussion and conclusions

The design of net zero energy buildings makes it necessary to further optimize thermal comfort and minimize the necessary energy for conditioning. Thermal comfort, influenced by thermal sensation is a key performance indicator. In this study we used a neuro-physiological model developed by Kingma et al. [2012], based on a mathematical model of human thermoregulation. In our research which was focused on the development of new comfort process control strategies, we used the outcome of one of our experiments to test and to apply the neuro-physiological model. It proved that the model could predict big change however in smaller changes its dynamic behavior is strongly fluctuating and no clear conclusions can be made. We agree with Schellen et al. [2013] that the advantage of using a thermo physiological model in combination with a thermal sensation model would be that thermal comfort could be controlled on a more individualized level under complex, daily practice encountered thermal environments. However, as also stated by Schellen et al. [2013], more research is needed before they can be used in daily building design practice.

References

- Akimoto, T., Tanabe, S., Yanai, T., Sasaki, M., 2010, Thermal comfort and productivity – Evaluation of workplace environment in a task conditioned office, *Building and Environment* 45: 45-50
- Arens, E., Zhang H., 2006, *The Skin's Role in Human Thermoregulation and Comfort, in Thermal and Moisture Transport in Fibrous Materials*, Woodhead Publishing Ltd
- Bauman, F., Baughman, A., Carter, G., Arens E., 1998, A field study of PEM (Personal Environmental Module) performance in Bank of America's San Francisco office buildings. CEDR-01-07.
- Dear, R. de, 2011, Revisiting an old hypothesis of human thermal perception: Alliesthesia, *Building Research & Information* 39(2):108-117
- Demeter, M., Wichman, P., 1991, Personal environmental module, European Patent EP0399003, <http://www.freepatentsonline.com/EP0399003.html>
- Filippini, G.J.A., 2009, De mens centraal bij het ontwerp van het binnenklimaat: ontwerp en ontwikkeling van een duurzaam lokaal klimatiseringsstelsel, MSc thesis Technische Universiteit Eindhoven.
- Guyton, A., Hall, J., 2000, *Textbook of Medical Physiology*, London, New York, W.B. Saunders Company. Chapter 48: 607-609; Chapter 73: 889-901.
- Hensel, H., 1981, *Thermal Sensation and Thermal Receptors in Man*, courtesy of Charles C Thomas Publishers, Springfield, Illinois.
- Hensel, H., Kenshalo, D., 1969, Warm receptors in the nasal region of cats. *Journal of Physiology* 204 (1):99-112.

- Kenshalo, D.R., 1970, Psychophysical studies of temperature sensitivity. In J.W. Neff (Ed.), Contributions to sensory physiology. New York Academic Press.
- Kingma, B.R.M., Saris, W.H.M., Frijns, A.J.H., Steenhoven, A.A. van, Marken Lichtenbelt, W.D. van, 2010, Modeling skin blood flow, A neuro-physiological approach, Proceedings Int. conf. on Fuzzy Computation and 2nd Int. conf. on Neural Computation
- Kingma, B., 2011, Human Thermoregulation: A synergy between physiology and mathematical modelling, PhD thesis, <http://arno.unimaas.nl/show.cgi?fid=24017>
- Kingma, B.R.M., Schellen, L., Frijns, A.J.H., Marken Lichtenbelt, W.D. van, 2012, Thermal sensation: a mathematical model based on neurophysiology, *Indoor Air* 22(3): 253-262
- Kingma, B.R.M., Frijns, A.J.H., Saris, W.H.M., van Steenhoven, A.A., Marken Lichtenbelt, W.D. van, 2014, Incorporating neurophysiological concepts in mathematical thermoregulation models, *Int J. Biometeorol* 58: 87-99
- Marken Lichtenbelt, W.D. van, Frijns, A.J.H., Fiala, D., Janssen, F.E.M., Ooijen, A.M.J. van, Steenhoven, A.A. van, 2004, Effect of individual characteristics on a mathematical model of human thermoregulation, *Journal of Thermal Biology* 29: 577-581
- Marken Lichtenbelt, W.D. van, Frijns, A.J.H., Ooijen, A.M.J. van, Fiala, D., Kerster, A.M., Steenhoven, A.A. van, 2007, Validation of an individualized model of human thermoregulation for predicting responses to cold air, *Int. J. Biometeorol* 51: 169-179
- Melikov, A.K., Knudsen, G.L., 2007, Human response to an individually controlled microenvironment. *HVAC&R Research* 13(4) 645-660
- Melikov A.K., 2004, Personalized ventilation, *Indoor Air* 14(7): 157-167
- Parkinson, T., Dear, R. de, Candidi, C., 2012, Perception of transient thermal environments: Pleasure and alliesthesia, Proceedings 7th Windsor Conference, Windsor, UK
- Schellen, L., Loomans, M.G.L.C., Kingma, B.R.M., Wit, M.H. de, Frijns, A.J.H., Marken Lichtenbelt, W.D. van, 2013, The use of a thermophysiological model in the built environment to predict thermal sensation. Coupling with the indoor environment and thermal sensation, *Building and Environment* 59: 10-22
- Schiavon, S., Melikov, A.K., 2009, Energy-saving strategies with personalized ventilation in cold climates. *Energy and Buildings* 41(5): 543-550.
- Schiavon, S., Melikov, A.K., Sekhar, C., 2010, Energy analysis of the personalized ventilation system in hot and humid climates. *Energy and Buildings* 42(5): 699-707.
- Stolwijk, J., 1971, A mathematical model of physiological temperature regulation in man. NASA Report CR-1855, Washington D.C.
- Vissers, D.R., 2012. The human body as sensor for thermal comfort control. Eindhoven University of Technology. Available at: <http://alexandria.tue.nl/extra2/afstversl/bwk/749062.pdf>.
- Watanabe, S., Melikov, A.K., Knudsen, G.I., 2010, Design of an individually controlled system for an optimal thermal microenvironment, *Building and Environment* 45: 549-558
- Zhang, H., Arens, E., Kim, D., Buchberger, E., Bauman, F., Huizenga, C., 2010, Comfort, perceived air quality, and work performance in a low-power task-ambient conditioning system, *Building and Environment* 45(1): 29-39.

Zhang, H., 2003, Human Thermal Sensation and Comfort in Transient and Non Uniform Thermal Environments, PhD Thesis; <http://repositories.cdlib.org/cedr/cbe/ieq/Zhang2003Thesis/>

Zhou, M., 1998, Human-centered control of the indoor thermal environment, PhD Thesis; <http://dspace.mit.edu/bitstream/handle/1721.1/10072/39241895.pdf>

Zotterman, Y., 1953, Special senses: thermal receptors, Annual Review Physiology 15:357-72.

An experiment on attention ability based on Electroencephalogram (EEG) in different PMV Conditions

Minjung Kim¹, Yoorim Choi¹, Jieun Han¹, Youngjoo Son¹, Chungyoon Chun^{1,*}

1 Yonsei University, Korea, chun@yonsei.ac.kr;

Abstract

Occupants' attention ability in seven PMV conditions is measured by means of electroencephalogram (EEG) and verbal voting. This can show us occupants' attention state change by time and environmental condition. To achieve the objective of this study, seven healthy male students' EEG was measured in seven PMV conditions each. Their EEG was measured in each condition for 65 minutes. EEG was measured on Fp1 and Fp2, and sorted out according to the frequency using power spectral analysis. The following results were achieved. First, in scope of moderate temperature environment, a higher level of attention was shown in relatively lower temperatures than in higher temperatures. Second, higher level of attention was shown in higher temperature in extreme condition compared to extremely cold temperature. Third, the occupants' attention ability, measured by EEG varied with time and was found to be different than the occupants' perceived attention from a verbal vote.

Keywords: Attention, EEG, PMV

1 INTRODUCTION

This study was conducted in the fall of 2013 as a follow-up of a previous research on stress that was carried out in the spring of 2013 (Choi, 2014; -Windsor Conference) in order to explore the attention ability of occupants based on EEG measurements, using the Predicted Mean Vote model.

Attention can be defined as the cognitive process of concentrating on something in order to complete a certain task within a specific time span (Silverman, 1964). While most studies have measured productivity as a result of performance, they have ignored the process of attention as a basic element of performance. Such methodology has missed the opportunity to explain the complicated process of how indoor environments affect the occupants' productivity both physiologically and psychologically.

Actually, many studies that have explored the effect of the indoor thermal environment on occupants' attention and productivity (Choi and Chun, 2009; Kim et al., 2007; Mazon, 2013; Tham and Willem, 2010) have used psychological paper tests to measure the attention ability, neglecting the process of how indoor environments can affect human productivity. Recently, many studies that have explored attention ability by using electroencephalogram (EEG) measurements have been published in different subject areas including education, physical education, ergonomics and human sensibility ergonomics (Derbali et al., 2011; Kim and Sul, 2003; Park et al., 2010; Shim and Seung, 2009). However, it would be useful to measure the effectiveness of brain activity related to temporal variations in attention using

approaches that rely on something other than paper tests. Electroencephalogram (EEG) is the recording of the electrical potential between various points on the surface of the scalp. The EEG signal can be analysed by reference to the time or the frequency domain of the signal. Frequency-domain analyses are based on measurements of the frequency of the signal, as in power spectral analysis (Hugdahl, 1995). In this way, the EEG is divided into the following frequency bands: delta (0-4Hz), theta (4-8Hz), alpha (8-13Hz), beta (13-30Hz) and gamma (30-50Hz).

In this study, Sensory Motor Rhythm (SMR) waves are used to investigate concentration. SMR waves are defined in the frequency range of 12-15 Hz and they encompass both alpha waves and beta waves. This frequency range is an attention-related range (Serman, 1977). The middle beta (16-20Hz) waves are often aroused when a person is engaged in high mental activity, such as learning, memorising or computing. Previous studies that have examined attention using EEG analysis applied the ratio of the theta wave activity, which is associated with the state of sleepiness, to the sum of the SMR wave activity and the middle beta activity. In this study, a specific power ratio, (SMR+Middle Beta/Theta) was used to analyse attention level (Lee et al., 2009).

In one of our previous research studies, which explored the effect of indoor air temperature on the occupants' attention ability based on electroencephalogram analysis, the EEG frequency showed that, for the selective attention aspect, the occupants' attention increased to a greater degree at a lower temperature (20.5°C) than it did at a neutral temperature (24.0°C). In addition, in the process of maintaining concentration, the occupants' attention was shown to occur more immediately at a lower temperature in comparison to a neutral temperature, and the occupants also achieved awakening status faster, enabling them to retain their attention (Lee et al., 2012). However, this study had some limitation in that the experiment was only conducted using two temperatures (20.5°C and 24.0°C).

In this context, the purpose of this study is to analyse the impact of the indoor air temperature (in the range from PMV-3 to PMV+3) on the occupants' attention ability based on electroencephalogram (EEG) measurements. The findings of this study can contribute to the findings from other research studies that have been carried out on the relationship between thermal environments and performance. Moreover, this study aims to identify the temporal variations of attention in different air temperatures.

2 METHODS

2.1 Experimental Conditions

The experimental period was from September to December in 2013. 7 male students (ages 22-28) participated in the study and received monetary compensation. Their participation was approved by the Institutional Review Board (IRB) at Yonsei University. The subjects reported that they were in good health and were not diagnosed with brain diseases. Experiments were conducted in a climate chamber in the Yonsei University. The experiments consisted of seven conditions, which were calculated by using the equation of Predicted Mean Vote by Fanger (1970). The air temperature was changed, as shown in Table 1. The other environmental conditions were: 50% relative humidity, 0.1m/s air velocity, 0.7clo clothing value and 1.0met metabolism. The subjects were placed in a pre-chamber, set at a neutral temperature (PMV0), in order to insure that they were thermally equal prior to the experiment. Figure 1 shows the feature of the climate chamber.

Table 1. Climate chamber conditions and related by PMV values

PMV	Air temperature (°C)	
	set	actual
-3	14.60	14.79 ± 0.06
-2	17.80	17.92 ± 0.06
-1	21.10	21.12 ± 0.03
0	24.40	24.40 ± 0.01
+1	27.60	27.47 ± 0.06
+2	30.80	30.81 ± 0.00
+3	33.80	33.80 ± 0.03

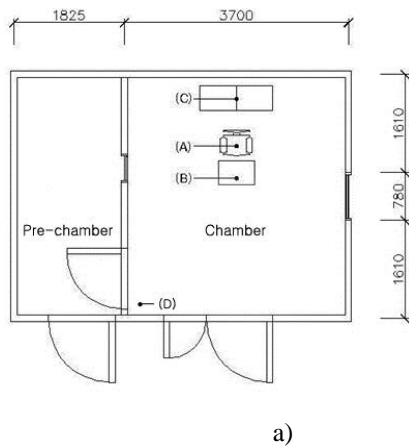

Figure 1. The feature of climate chamber. a) Plan of the chamber b) Participant wired with and EEG electrode

2.2 Measuring Tools: EEG recording System

The electroencephalogram (EEG) was recorded with Ag/AgCl electrodes from 8 scalp locations by 10-20 system (Jasper, 1958) using an electrode cap. The right earlobe served as reference. The recording locations included 4 lateral sites to the left of the midline (Fp1, F3, T3, P3), and their homologous sites to the right of the midline as shown in Figure 2. Electrooculogram (EOG) was recorded for artifacts including blinks and eye movements using disposable surface electrodes (Tyco Healthcare Group LP, Norwalk, CT, USA). All signals were recorded with bio-signal instrumentation system MP150 (Biopac system Inc., Santa Barbara, CA, USA). A 0.1-35Hz band-pass filter was used for all online recordings. EEG and EOG were sampled at 1000Hz. A Power Spectral Density using the 'BrainMap-3D' S/W (Laxtha, Daejeon, Korea) was computed to divide the EEG raw signal into the three following frequencies: Theta (4-8Hz), SMR (12-15Hz) and Middle Beta (16-20Hz) in order to compute the attention level ((SMR+M-Beta)/Theta) as described above.

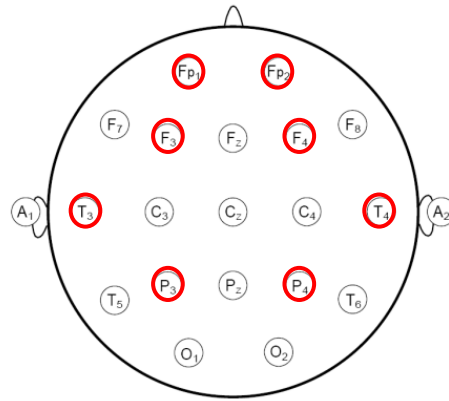

Figure 2. International 10-20 system of electrode placement (Jasper, 1958)

2.3 Experimental Procedures

Each subject was exposed to seven different PMV conditions, i.e. one condition per day. EEG electrodes were attached after the subjects put on sweatshirts and pants. The subjects then sat in the pre-chamber for 15 minutes in order to adapt to the neutral environment. They then moved to the climate chamber and the electrodes were connected to a computer. During the experiment, the subjects were asked to study or read a book for 65 minutes. After measuring EEG for 65 minutes, the subjects were asked to answer how well they were able to concentrate, selecting from a response range that varied from ‘Couldn’t concentrate at all’ to ‘Concentrated very well’. To control the order effect, the experimental condition order of each of the subjects was different, as shown in Table 2. In total 49 experiments were conducted.

Table 2. Order of the experiment for each subject

	Day 1	Day 2	Day 3	Day 4	Day 5	Day 6	Day 7
Subject A	PMV-3	PMV-2	PMV-1	PMV0	PMV+1	PMV+2	PMV+3
Subject B	PMV-2	PMV-1	PMV0	PMV+1	PMV+2	PMV+3	PMV-3
Subject C	PMV-1	PMV0	PMV+1	PMV+2	PMV+3	PMV-3	PMV-2
Subject D	PMV0	PMV+1	PMV+2	PMV+3	PMV-3	PMV-2	PMV-1
Subject E	PMV+1	PMV+2	PMV+3	PMV-3	PMV-2	PMV-1	PMV0
Subject F	PMV+2	PMV+3	PMV-3	PMV-2	PMV-1	PMV0	PMV+1
Subject G	PMV+3	PMV-3	PMV-2	PMV-1	PMV0	PMV+1	PMV+2

3 RESULTS

In this study, Fp1 and Fp2 EEG channels were analysed since previous studies on attention ability using the frequency of SMR+Middle Beta/Theta also analysed those two channels (Jang and Lee, 2008; Lee et al., 2012; Lee et al., 2009).

3.1 Attention Ability in Mild Temperatures

In this part of the experiment, the level of attention in PMV+1, 0 and -1 conditions was compared because a space that is hotter than PMV+1 or colder than PMV-1 is unsuitable for an actual indoor environment.

Figure 3 shows the brain mapping of the attention response variation with time for PMV=-1, PMV=0 and PMV=+1. The 65 minutes of exposure time was divided into

13 sections by five-minute intervals. The values of relative power are expressed by colour in high-to-low order: red, orange, yellow, green, blue, and violet.

At all times, the pre-frontal lobe brain activity of the occupants was higher in the PMV0 and PMV-1 conditions than it was in the PMV+1 condition. The brain activity was higher in the PMV-1 condition than it was in the PMV0 condition during the first half of the exposure (1-30 min.), but it was higher in the PMV0 condition than it was in the PMV-1 condition in the latter half of the exposure (30-65 min.).

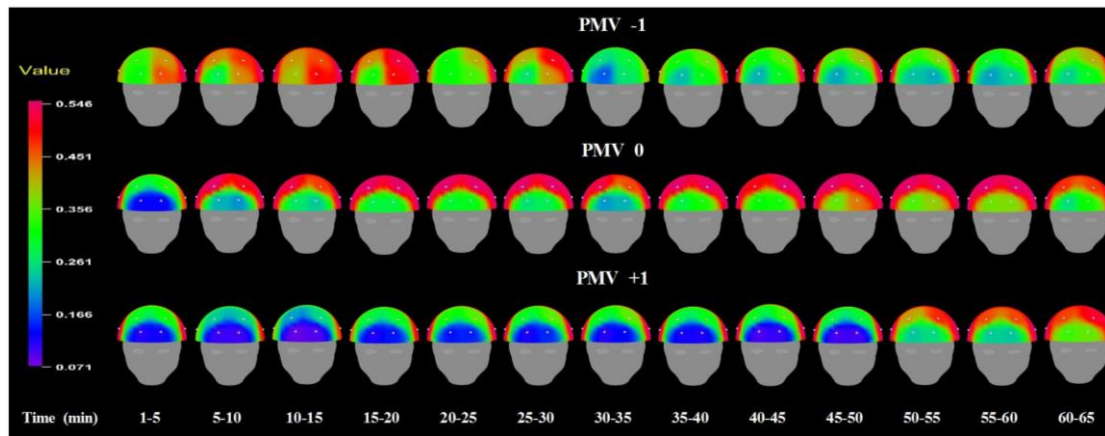

Figure 3. Mapping for the attention with time in PMV-1, PMV0 and PMV+1

Figure 4 shows the result of mapping as a graph. There seems to be a reverse phenomenon starting from 30 minutes between the PMV0 condition and the PMV-1 condition, as mentioned above.

Lee et al (2012) mentioned that a PMV-1 condition is more favourable for selective function of attention than a PMV0 condition, and this finding is also supported by the results of this current research. However, this current study also found that a reverse phenomenon occurred between the PMV0 and PMV-1 conditions after 30 minutes.

The EEG of attention was relatively low in the PMV+1 condition as compared to the PMV0 or PMV-1 conditions in all the experimental times except for last 10 minutes. In order to examine the continuous aspect of this progress, it is necessary to expand the length of the experimental time.

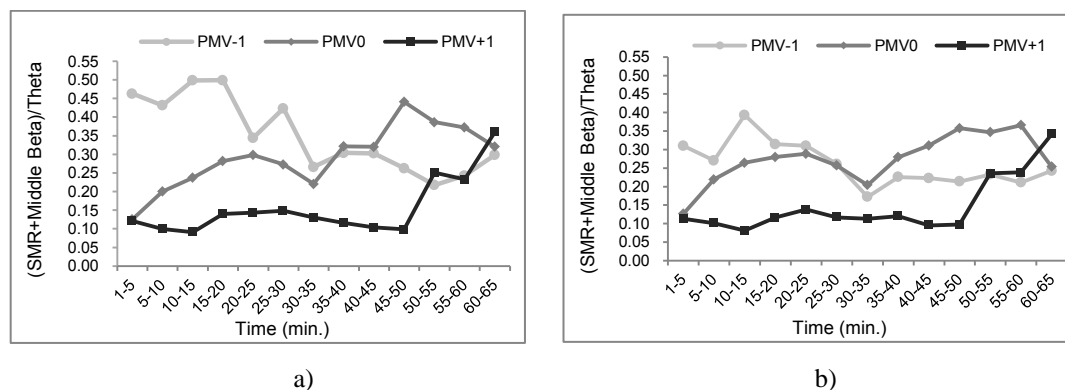

Figure 4. Temporal variation of attention in the pre-frontal lobe. a) Fp1, b) Fp2

3.2 Attention Ability in Extreme Temperatures

Figure 5 shows the course of attention (SMR+Middle Beta/Theta) in the pre-frontal lobe with time in low (PMV-3&-2) and high (PMV+3&+2) temperatures. The brain activity in a low temperature environment means the mean value of the brain activity in PMV-3 and -2 conditions; in a high temperature environment, the mean value of the brain activity in PMV+3 and +2 conditions. At the beginning of experiment, the low temperature environment was slightly better for concentration as compared to the high temperature environment. However, after 25 minutes, a significant change in the ability to concentrate occurred between the low temperature environment and the high temperature environment. The brain was activated to a greater degree in the high temperature environment than it was in the low temperature environment. It seems that, after 25 minutes, the occupants were able to maintain continuous attention better in an environment with an extremely higher temperature than in an environment with an extremely lower temperature.

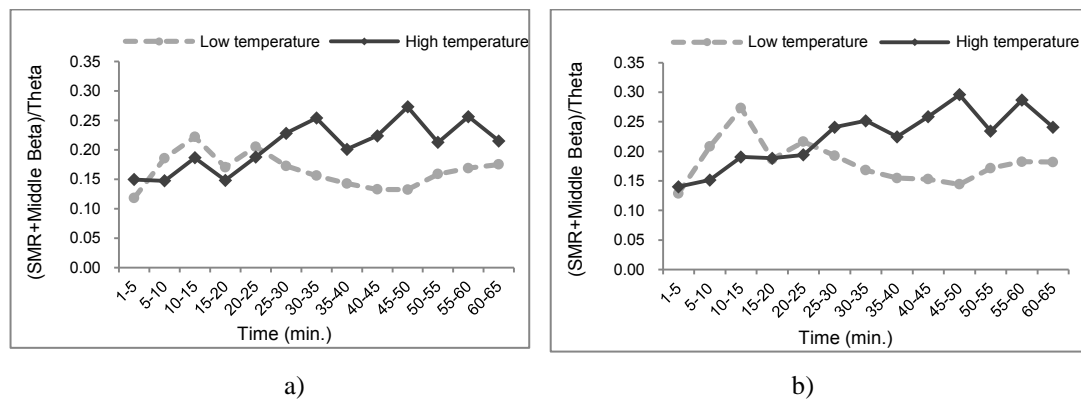

Figure 5 Temporal variation of attention in the pre-frontal lobe in high and low temperature. a) Fp1, b) Fp2

3.3 Comparison with Perceived Attention

Figure 6 shows the attention (SMR+Middle Beta/Theta) in the pre-frontal lobe with PMV after 60 minutes, and Figure 7 shows the verbal vote of perceived attention at the same time (0 = couldn't concentrate at all; 6 = concentrated very well). Broadly speaking, the aspect of brain activity seems similar to the verbal vote of perceived attention in the left and right pre-frontal lobe. Based on the EEG analysis, the highest attention level occurred in the PMV+1 condition, but in the verbal vote it occurred in both the PMV0 condition and the PMV+1 condition. For the verbal vote, the lowest attention level occurred in the higher temperature environment (PMV+2, PMV+3), while the lowest brain activity occurred in the low temperature environments (PMV-2, PMV -3).

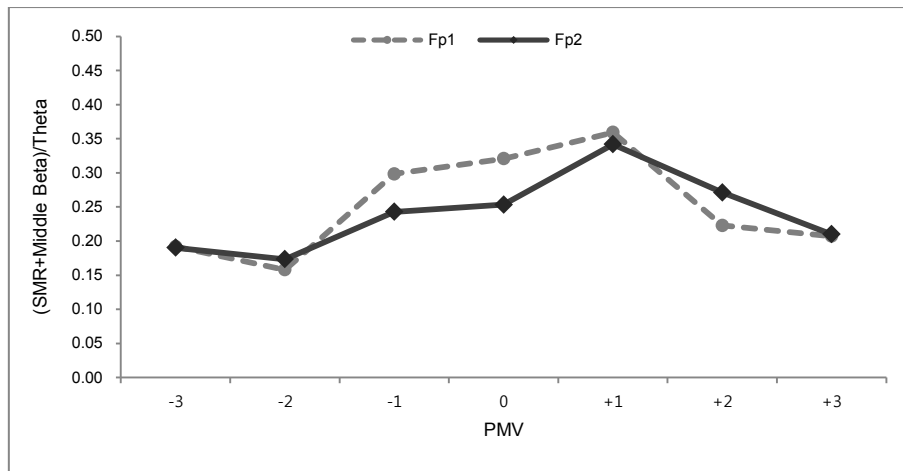

Figure 6 Attention in the pre-frontal lobe with PMV after 60min

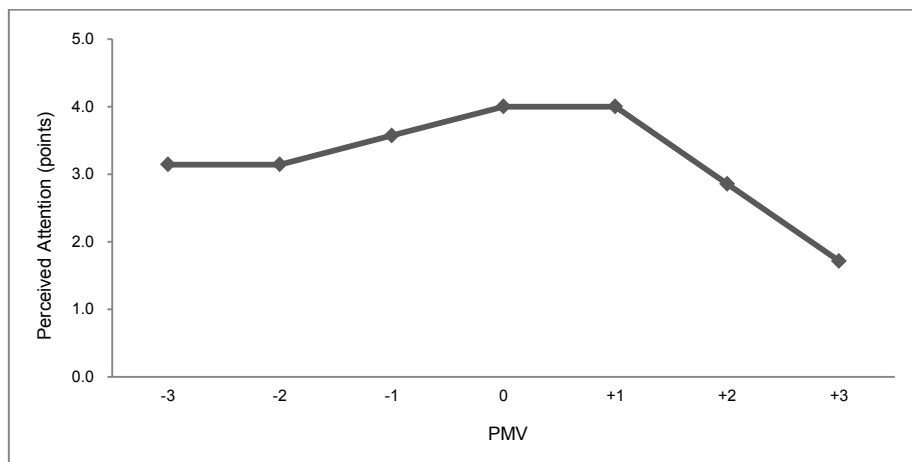

Figure 7 Perceived attention with PMV

Figure 8 shows the brain activity of attention in the pre-frontal lobe with PMV from the beginning of the experiment, at five minutes, and after 60 minutes. The brain was most activated in the PMV-1 condition right after the beginning of the experiment, while it was most activated in the PMV+1 condition at the end of the experiment. It seems that the occupants' attention ability, as measured by EEG, varies over time. When starting the experiment, the brain activity in the PMV-1 condition was found to be significantly higher than it was in the other conditions. However, the difference between the conditions decreased after 60 minutes and the highest brain activity was found to occur in the PMV0 and PMV+1 conditions. This suggests that indoor air temperature increasing affects the occupants' attention early in the process of concentrating, but it seems that the effect of temperature decreases as the occupants adapt to the environment as time goes by.

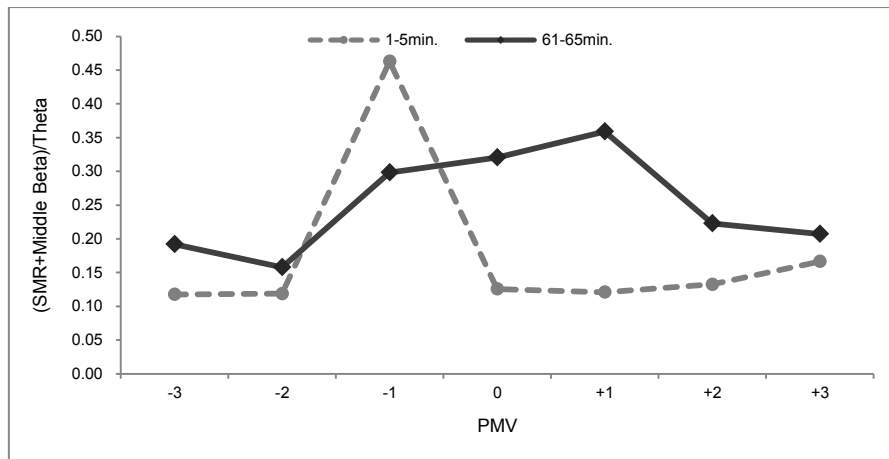

Figure 8 Comparison of attention by time passed

4. CONCLUSIONS

This study was conducted in various indoor air temperature environments using a PMV model based on EEG measurement in order to investigate the effect of indoor air temperature on the occupants' attention ability. The following are some of the insights gained from the experiment.

Relatively lower temperature had the advantage of increasing the occupants' attention at the beginning of the experiment. However, higher temperature had the advantage of maintaining the occupants' attention after 25 minutes (in extreme conditions) and after 30 minutes (in moderate conditions).

The increase in attention was the best at the beginning of the PMV-1 condition. This effect from temperature was decreased over time. After one hour, not much difference in the ability to maintain attention was found between the PMV-1 condition and the PMV +1 condition, and the PMV+1 was the best condition.

The results for perceived attention by verbal vote were different than the results for brain activity. The subjects noted that the PMV0 condition and the PMV+1 condition were both best for attention, but brain activity was better in the PMV+1 condition.

In conclusion, indoor thermal environments that support attention should be changed over time. This dynamic control of air temperature is required technology in places where occupants need to focus their attention, such as offices, classrooms, laboratories, etc.

Acknowledgements

This research was supported by Mid-career Researcher Program through the National Research Foundation of Korea(NRF) funded by the Ministry of Education, Science and Technology(NRF-2013R1A2A2A01068823)

References

Choi, Y. & Chun, C., 2009. The Effect of Indoor Temperature on Occupants' Attention Abilities. *Journal of the Architectural Institute of Korea*, 25(12), pp 411-418.

- Derbali, L., Chalfoun, P. & Frasson, C., 2011. Assessment of Learners' Attention While Overcoming Errors and Obstacles: An Empirical Study. *Artificial Intelligence in Education*, 6738, pp 39-46.
- Fanger, P.O., 1970. *Thermal comfort*, Copenhagen : Danish Technical Press.
- Hugdahl, K., 1995. *Psychophysiology: The mind-body perspective*, Cambridge : Harvard University Press.
- Jang, S. & Lee, H., 2008. The Effect of Musical Genre on Mental Focusing. *Korean Journal of Psychology*, 2008, pp 262-263.
- Jasper, H. H., 1958. The ten twenty electrode system of the international federation. *Electroencephalography and clinical neurophysiology*, 10, pp 371-375.
- Kim, D., Kim, S., Park, S., Jeon, M., Kim, G., Kim, C., Chung, J., Baek, S. & Sakong, J., 2007. The Effects of Indoor Air Quality on the Neurobehavioral Performance of Elementary School Children. *Annals of Occupational and Environmental Medicine*, 19(1), pp 65-72.
- Kim, J. & Sul, J., 2003. The Effects of the Concentration and Imagery Through the Regulation of the Brain Wave on the Performance Learning of Golf Putting. *Journal of Korean Society of Sport Psychology*, 14(3), pp 355-364.
- Lee, C., Kwon, J., Kim, G., Hong, J., Shin, D. & Lee, D., 2009. A Study on EEG based Concentration Transmission and Brain Computer Interface Application. *Journal of the institute of electronics engineers of Korea*, 46(2), pp 41-46.
- Lee, H., Choi, Y. & Chun, C., 2012. Effect of Indoor Air Temperature on the Occupants' Attention Ability based on the Electroencephalogram Analysis. *Journal of the Architectural Institute of Korea*, 28(3), pp 217-225.
- Mazon, J., 2013. The influence of thermal discomfort on the attention index of teenagers: an experimental evaluation. *International journal of biometeorology*, pp 1-8.
- Park, S., Hu, H. & Lee, W., 2010. A Study on Physiological Signal Changes Due to Distraction in Simulated Driving. *Journal of the Ergonomics Society of Korea*, 29(1), pp 55-59.
- Shim, J. & Seung, I., 2009. Influences of Brain Education Program on Concentration and Prefrontal EEG Activation of Children`s. *Journal of the Korean Society for Child Education*, 18(3), pp 19-36.
- Silverman, J., 1964. The problem of attention in research and theory in schizophrenia. *Psychological Review*, 71(5), pp 352.
- Sterman, M., 1977. Sensorimotor EEG operant conditioning: Experimental and clinical effects. *The Pavlovian Journal of Biological Science: Official Journal of the Pavlovian*, 12(2), pp 63-92.
- Tham, K. W. & Willem, H. C., 2010. Room air temperature affects occupants' physiology, perceptions and mental alertness. *Building and Environment*, 45(1), pp 40-44.

The occupants' stress on each PMV condition – chamber study using brain wave

Yoorim Choi¹, Yongmin Kim¹, Chungyoon Chun¹

1 Yonsei University, South Korea, chun@yonsei.ac.kr

Abstract

This study is designed to investigate the relationship between the thermal comfort environment and stress using brain wave analysis. To achieve this purpose, an experimental approach in a climate chamber based on PMVs was adopted. Environmental factors were set with the PMV scale ranging from -3 to +2. The brain waves of each of the participants (N=7; males) were measured in six conditions, in the PMV order from cold to hot, i.e. one condition per day. The results suggest that the participants felt least stressed under the PMV 0 and most stressed under the PMV -3 and +2. In addition, the stress levels arising from the brain waves varied with time. For an immediate exposure, an order effect was found. Participants felt more stressed in the process of PMV change from 0 to +1, compared to PMV +1 to PMV +2. However, in one hour, they felt most stressed in the hottest environment condition.

Keywords: Thermal comfort, Stress, Brain wave (EEG)

1 Introduction

Numerous studies on thermal comfort have discussed human thermal sensation with regard to physical environment in a climate chamber based on verbal voting. The results of these studies have led to the development of thermal comfort indices such as PMV (Fanger, 1970), and these indices have contributed to a more pleasant indoor thermal environment plan.

Some studies examined physiological reactions of humans to the surrounding physical environment. Representative studies discussed the interaction between physical environment and human body by measuring skin temperature or blood flow and by predicting thermal comfort state of occupants (Arens et al., 2006; Gagge et al., 1967; Kingma et al., 2011; Savage & Brengelmann, 1996).

More recently, brain has recently become the link between human physiology, on the one hand, and cognitive science, on the other hand. The remarkable development of brain sciences provided various clues for understanding human body and mind, and the new methodologies of brain sciences have integrated into different research fields. The research area that focuses on thermal comfort and investigates thermal environment around human body and relevant human reactions should join the trend. Accordingly, this study intended to use brainwave measurement in the field of thermal comfort.

In the first step of this experiment, the degree of stress in occupants according to 6 PMV conditions was examined by brainwave measurement. This degree of stress is the level of relaxation of unstressed occupants. The results of this study can be used for in future for planning the relaxed indoor environment.

2 Methods

2.1 Experimental Condition

The experiment was carried out in the 3.7m×4.0m×2.0m (W×D×H) climate chamber in March, 2013. Air temperature was set with the PMV scale from -3 to +2 (see Table 1). The control conditions for other environmental factors are shown in Table 2. All participants were exposed to six different thermal conditions. The pre-chamber was set to the neutral temperature with the PMV scale equal to zero. Participants waited in the pre-chamber to adapt to the thermal neutral environment before the experiment.

Table 1. Climate chamber conditions based on PMVs.

PMV scale	Air temperature (°C)	
	Setting value	Actual value
-3	15.80	15.88±0.14
-2	18.80	18.86±0.11
-1	21.80	21.81±0.06
0	25.00	25.01±0.06
+1	28.00	28.01±0.05
+2	31.00	30.99±0.13

Table 2. Control conditions for other environmental factors

Factors	Conditions controlled
Relative Humidity	50 %
Air velocity	< 0.1 m/s
Participants' clothing values	0.7 clo
Participants' metabolic rate	1.0 met
Intensity of illumination on the desk surface	893.41 lx

2.2 Experimental tools and procedures

EEG (Brain waves) is the recording of minute electrical activity on the surface of the scalp. The waves are divided into bands by frequency in the high-to-low order: Delta, Alpha, Beta, and Gamma. Each band has varying characteristics and reflects the function of the brain and the activity of the nervous system. Alpha waves are mainly used to measure a relaxed state of human body. On the contrary, beta waves are used to measure a tensed state. While aroused state includes positive effects, a negative highly tensed state is measured by high beta waves. Gamma waves appear when human body undergoes extreme agitation.

Table 3. EEG frequency bands.

Frequency	EEG rhythm	Neural functions and behaviors
~ 4Hz	Delta (δ)	Sleep (non-REM)
4 ~ 8 Hz	Theta (θ)	Sleep, Sleepiness
8 ~ 13 Hz	Alpha (α)	Physical relaxation, Mental inactivity
13 ~ 30 Hz	Beta (β)	Mental activity, Arousal, Strained
30Hz ~	Gamma (γ)	Nervousness, High-level information processing

In this experiment, 8 EEG channels of MP 150 (Biopac System Inc., Santa Barbara, CA, USA) were applied to record EEG and to analyze the process of stress. Cap-style brain wave electrodes were placed onto the frontal lobe, the temporal lobe, and the parietal lobe (Fp1, Fp2, F3, F4, T3, T4, P3, and P4) in accordance with the international 10-20 system of electrode placement (Jasper, 1958), and a reference electrode was an earlobe (A1) (Figure 1). Seven healthy male undergraduates participated in the experiment. Their participation was approved by the IRB board at Yonsei University. Figure 2 shows the experimental procedure, which was identically implemented for all the participants. All of them were exposed to the conditions in the order of PMV from cold to hot (PMV-3 → PMV-2 → PMV-1 → PMV0 → PMV+1 → PMV+2). They participated in one condition per day in the same time period. To control the biorhythm of the day, the experiments were divided into three time periods: morning, afternoon, and evening. Each participant wore the experimental suit (0.7clo) and adapted to the neutral (PMV=0) condition in the pre-chamber. After the brain electrodes were attached to each participant in the pre-chamber, the participant was allowed to enter the climate chamber. Then, the participant was instructed to read materials for 65 minutes. EEG data associated with stress were collected two times (between 2~4 minutes and between 63~65 minutes). In this experiment, the relative Alpha (α) wave related with relaxation reflecting the non-stressed status, and the relative High-beta ($h\beta$) wave related to arousal as a stressed status were measured. All EEG data were analyzed after removing artifacts caused by EOG (electrooculogram) and filtering.

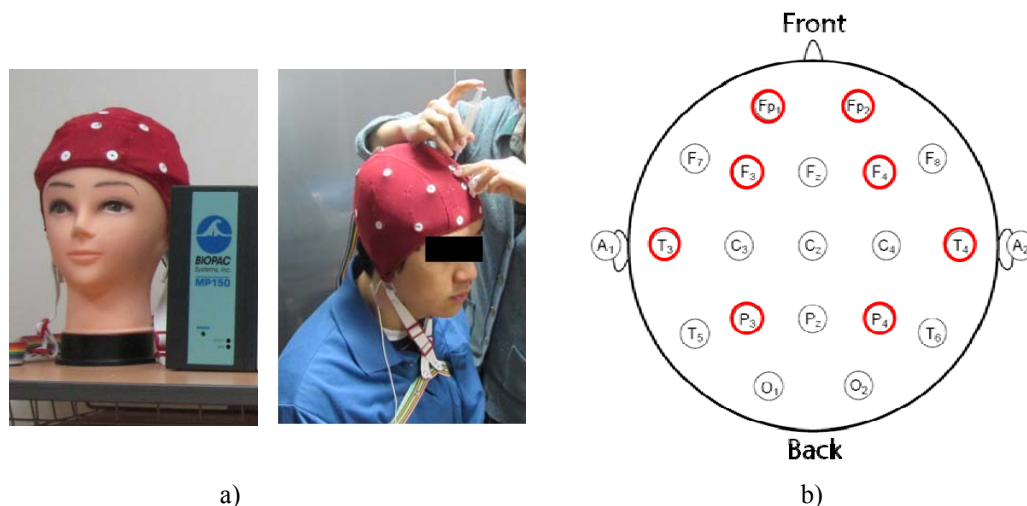
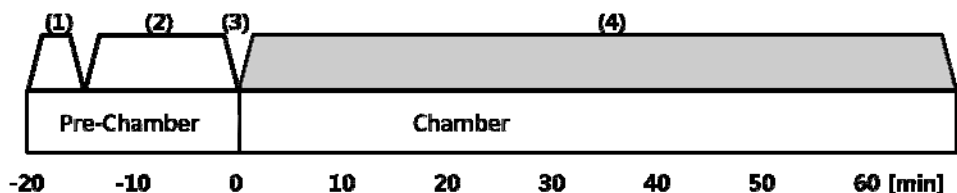

Figure 1. Electrodes; a) cap-style electrodes, b) electrodes placements



- (1) Pre-chamber | Put on experimental suit (0.7clo)
- (2) Pre-chamber | Adjust to neutral temperature & Attach brainwave electrodes
- (3) Pre-chamber | Enter the climate chamber
- (4) Chamber | Read materials & Collect EEG data

Figure 2. Experimental procedure

3 Results

3.1 Stress-related brain mapping on PMVs

Brain mapping analysis for the visualization of the EEG power was conducted using the 'BrainMap-3D' S/W (Laxtha, Daejeon, Korea). EEG data that contained artifacts were excluded from the final dataset. The mean of relative power for each region and frequency were used to analyze the brain mapping. The relative Alpha wave associated with physical relaxation and mental inactivity was analyzed to show the inverse situation of stress, and the relative High-beta wave associated with high arousal was analyzed to show the degree of stress. Values of relative power were expressed by colour in the high-to-low order: red, orange, yellow, green, blue, and violet. Visualizations of the mapping for the relative Alpha wave and the relative High-beta wave between 2~4 minutes are as follows (see Figure 3).

In case of PMV -3 (15.8°C/50%), an activity of the relative Alpha wave measured well at the back of the head was shown only in the parietal lobe (P3, P4). In case of PMV -2 (18.8°C/50%), an activity of the relative Alpha wave expanded from the parietal lobe (P3, P4) to the frontal lobe (F3, F4). It means that the participants felt more relaxed in PMV -2 than in PMV -3. In case of PMV -1 (21.8°C/50%), an activity of the relative Alpha wave expanded to the temporal lobe (T3, T4). Reactions of the prefrontal lobe (Fp1, Fp2) were not powerful; however, the overall relaxation increased. In case of PMV 0 (25.0°C/50%), an activity of the relative Alpha wave was observed in almost every part of the brain. The reaction of the right temporal lobe (T4) decreased; however, it can be assumed that a thermal indoor environment with PMV scale reaching 0 was most relaxing for the participants. In case of PMV +1 (28.0°C/50%), an activity of the relative Alpha wave decreased. The participants were starting to find it difficult to relax. In case of PMV +2 (31.0°C/50%), an activity of the relative Alpha wave expanded to the frontal lobe (F3, F4). This suggests that the participants were perhaps not relaxed but rather drowsy from the heat. Alpha wave can be activated as a state opposite to the tension state caused by loosening of the body by heat.

In case of PMV -3 (15.8°C/50%), a stronger activity of the relative High-beta wave was observed on both sides of the temporal lobe (T3, T4). This means that the participants were under a lot of stress. In case of PMV -2 (18.8°C/50%), the overall activity of the relative High-beta wave decreased. This can be explained by the participants' adapting to the cold environment after being exposed to PMV -3. In case of PMV -1 (21.8°C/50%), an activity of the relative High-beta wave was observed on both sides of the temporal lobe (T3, T4); however, the value of the left temporal lobe (T3) was lower than in the PMV -3 condition. In case of PMV 0 (25.0°C/50%), the greater part of the brain appeared bluish except for the right temporal lobe (T4), and the reaction of the left temporal lobe (T3) decreased more. It can be assumed that a thermal indoor environment with PMV scale reaching 0 was the best for the participants' stress-free state, as they showed the lowest stress level in this thermal indoor environment. In case of PMV +1 (28.0°C/50%), the values of the relative High-beta wave were most activated, and, as with PMV -3, the stronger activity of the relative High-beta wave was observed on both sides of the temporal lobe (T3, T4). This means that the participants were under a lot of stress in this thermal environment. In case of PMV +2 (31.0°C/50%), the activity of the relative High-beta wave decreased in the overall part of the brain similar to the PMV -2 condition. It can be assumed that participants might have adapted to the hot environment after being exposed to PMV +1. All participants were exposed to the conditions ranging from discomfort (PMV -3) to comfort (PMV 0) and then from comfort (PMV 0) to discomfort (PMV +2). Throughout this process, the results suggest that the participants felt much stress when the condition changed from comfort (PMV 0) to

discomfort (PMV +1). Thus, they showed a more stressed status under PMV +1 than PMV +2.

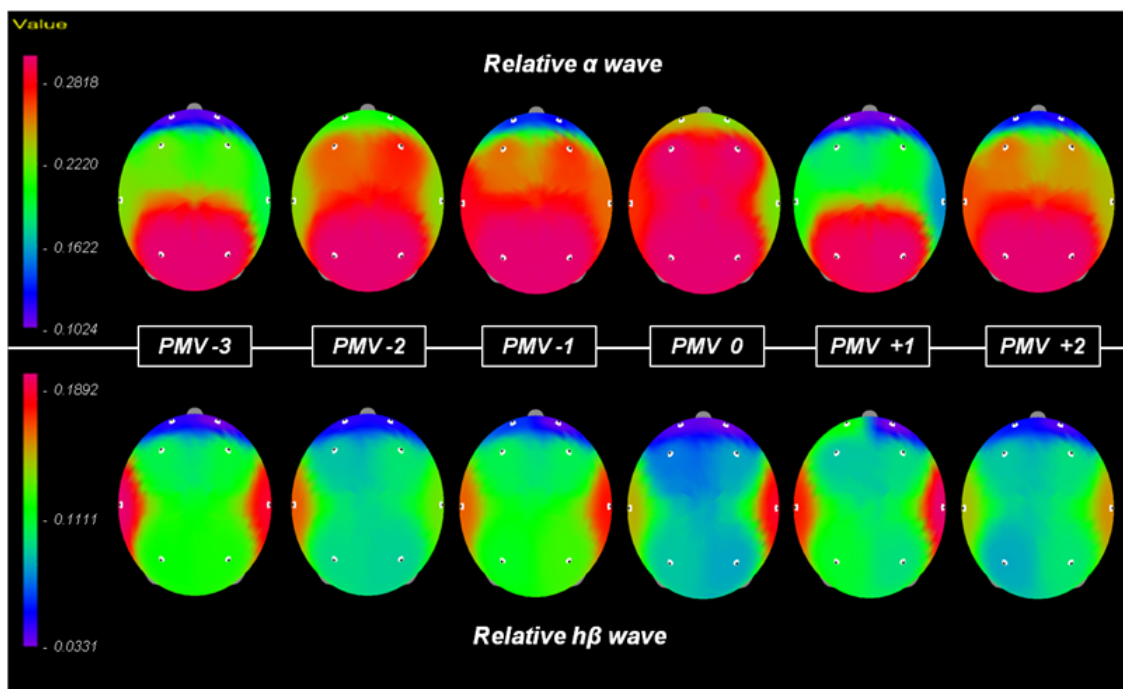

Figure 3. Mapping for relative Alpha wave and the High-beta wave based on PMVs (between 2~4 minutes)

3.2 The change of EEG with time

As concerns the mapping of the relative Alpha wave and the High-beta wave based on PMVs (see Figure 3), the relative alpha waves typical for a stress-free relax state became more activated in the direction from the parietal lobe (P3, P4) to the frontal lobe (F3, F4) as the experimental settings changed from PMV -3 (the coldest environment) toward the PMV 0 (neutral thermal environment). On the other hand, those relative High-beta waves characterizing the stressed state were most activated in the temporal lobe under all PMV conditions. In this study, the relative alpha waves (relax state) became more activated along the parietal lobe (stable state) and the frontal lobe (recognition, emotion) as they approached the thermal neutral environment. In addition, the relative High-beta waves (stressed state) became more activated along the temporal lobe (stress-related emotion). Based on these findings, the PMV-based activation analysis of the relative alpha waves along the frontal lobe (F3, F4) and the relative High-beta waves along the temporal lobe (T3, T4) can be summarized as follows (see Figure 4).

Figure 4 shows the relative Alpha wave in the frontal lobe between 2~4 minutes. The power of the relative Alpha wave showed the highest value in a thermal indoor environment with PMV 0; on the contrary, it showed the lowest value in a thermal indoor environment with PMV +1. Consequently, in case of the relaxation associated to the relative Alpha wave, a thermal indoor environment characterised by PMV 0 was most relaxing. By contrast, the participants found it difficult to relax in a thermal indoor environment with PMV -3 and +1. In case of a hot thermal indoor environment (PMV +2), participants were possibly drowsy from the heat. Then, the value of the relative Alpha wave increased due to the brain inactivity. It highlights drowsiness, a condition that is somewhat different from relaxation.

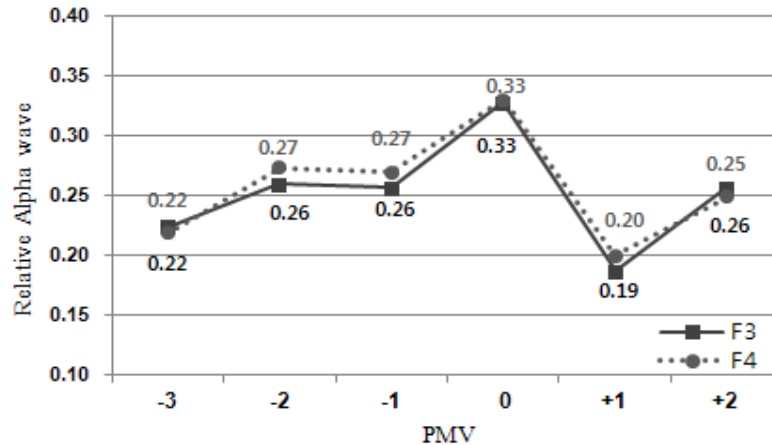

Figure 4. Relative Alpha wave in the frontal lobe based on PMVs (between 2~4 minutes)

Figure 5 shows the relative High-beta wave in the temporal lobe between 2~4 minutes. The power of the relative High-beta wave was slightly different between the left temporal lobe and the right temporal lobe. In case of the left temporal lobe (T3), the power of the relative High-beta wave was the lowest value in a thermal indoor environment with PMV, 0 and the highest in a thermal indoor environment with PMV -3; conversely, in case of the right temporal lobe (T4), it yielded the lowest value in a thermal indoor environment with PMV -2 and the highest value in a thermal indoor environment with PMV +1. Consequently, in case of the stress associated to the relative High-beta wave, a thermal indoor environment with PMV 0 reduced the participants' stress most effectively. By contrast, participants in a thermal indoor environment with PMV -3 and +1 were in most stressed condition

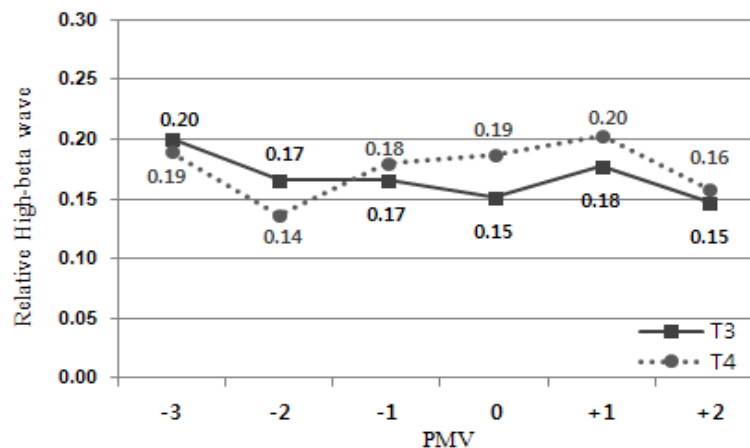

Figure 5. Relative High-beta wave in the temporal lobe based on PMVs (between 2~4 minutes)

Figure 6 shows these stress-related relative High-beta waves measured in the temporal lobe after one hour (63~65 minutes). The reaction of the right temporal lobe (T4) was the highest under PMV -1, while the reaction of the left temporal lobe (T3) was the lowest under PMV -2 and -3. The most remarkable difference of High-beta waves after one hour (63~65 minutes), compared to 2-4 minutes, was that they became more activated under PMV +2 previously

under PMV +1. This phenomenon was observed in both the left temporal lobe (T3) and the right temporal lobe (T4).

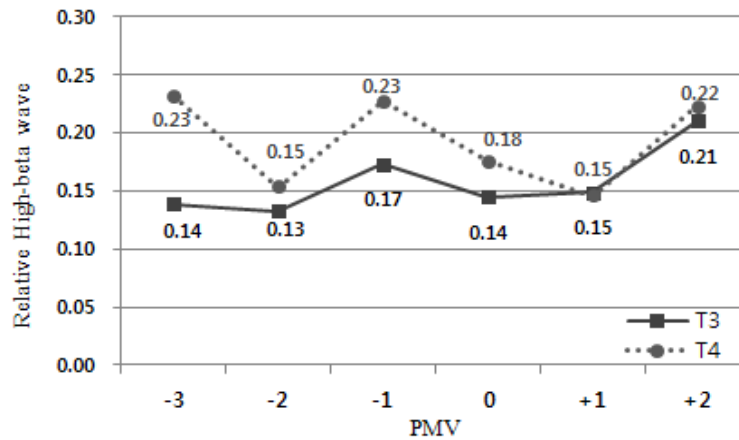

Figure 6. Relative High-beta wave in the temporal lobe based on PMVs (between 63~65 minutes)

4 Conclusions

This study was conducted to examine the EEG associated with stress across six PMV conditions. The following conclusions can be drawn based from the results of this study. First, the participants felt least stress under PMV 0 (thermal neutral environment) and the highest level of stress under PMV -3 (the coldest environment). In an hour, they felt most stress under PMV +2 (the hottest environment) as well. Second, the stress levels based on the EEG varied with time. For an immediate (2~4 minutes) exposure to all indoor thermal environments (from PMV -3 to PMV +2), the participants felt more stressed in the process of change from thermal neutral environment (PMV 0) to the hotter environment (PMV +1) than in the change from PMV +1 to PMV +2. This showed the order effect of the experiment. It can be explained by the participants' feeling much stress when they were exposed to the unexpected discomfort in the sequence where there was an effect of the previous experience in spite of more than one-day interval. On the contrary, in an hour, they felt most stressed in the hottest environment.

Acknowledgements

This research was supported by Mid-career Researcher Program through the National Research Foundation of Korea (NRF) funded by the Ministry of Education, Science and Technology (MEST) (NRF-2013R1A2A2A01068823).

References

- Arens, E., Zhang, H., Huizenga, C., 2006. Partial- and whole body thermal sensation and comfort, Part I: uniform environmental conditions. *Journal of Thermal Biology*, 31, pp 53–59.
- Arens, E., Zhang, H., Huizenga, C., 2006. Partial- and whole body thermal sensation and comfort, Part II: non-uniform environmental conditions. *Journal of Thermal Biology*, 31, pp 60–62.
- Fanger, P.O., 1970, *Thermal comfort*, Copenhagen: Danish Technical Press,

Gagge, A.P., Stolwijk, J.A.J., Hardy, J.D., 1967. Comfort and thermal sensations and associated physiological responses at various ambient temperatures. *Environmental Research*, 1(1), pp 1–20.

Jasper, J.J., 1958. The ten-twenty electrode system of the international federation. *Electroencephalography and Clinical Neurophysiology*, 10, pp 371-375.

Kingma, B.R.M., Frijns, A.J.H., Saris, W.H.M., van Steenhoven, A.A., van Marken Lichtenbelt, W.D., 2011. Increased systolic blood pressure after mild cold and rewarming: relation to cold-induced thermogenesis and age, *Acta Physiologica*, 203(4), pp 419–427.

Tracking hand movement in an infrared image

M. Veselý¹, W. Zeiler²

Department of Built Environment, Eindhoven University of Technology, P.O. Box 513, 5600
MB Eindhoven, Netherlands

¹M.Vesely@tue.nl, ²W.Zeiler@tue.nl

Abstract:

The skin temperature and thermal comfort are closely related and change in skin temperature can predict thermal discomfort even before it is consciously perceived. The effect of changing thermal environment is most significant on the body extremities, particularly hands in cool and head in warm conditions. The skin temperature of the extremities can thus become a feasible control signal for personalized conditioning.

In order to use a skin temperature of the extremities in practice as a control signal, it is necessary to measure it in a way that does not hinder a user. The infrared thermography represents a method that has a potential to fulfill this criterion. However, remote sensing of temperature arises new challenges how to track a movement of the human body in order to get a correct temperature of the chosen body part. This paper discusses a method based on pattern matching for real time tracking of hand movement in an infrared image.

Keywords: Infrared thermography, Pattern matching, Thermal comfort

1 Introduction

The building industry nowadays is facing two major challenges – an increased concern for energy consumption and a need for comfort improvement. These challenges led many researchers to develop a personalized conditioning system. Personalized conditioning climatizes only a small space around a single person. This makes it possible to satisfy different needs of every individual and to reduce energy consumption due to higher effectiveness. Different personalized conditioning systems have been introduced, including personalized ventilation (Melikov 2004), local floor heating (Foda & Sirén 2012), or a combination of personalized ventilation with local convective and radiant heating (Melikov & Knudsen 2007; Watanabe et al. 2010). However, these systems are still controlled only by user interaction, which can lead to problems such as lower thermal comfort due to rebound or overshoot or loss of effectiveness due to incorrect use of the system. Therefore, it is needed to seek for methods that can help to automate the control process of personalized conditioning.

An effective automatic control of personalized conditioning first requires a parameter, which is related to comfort and convenient to measure in an office environment. Wang et al. (2007) showed that the fingertip temperature is related to a risk of cold discomfort. They identified a clear threshold of fingertip temperature of 30 °C, above which no risk of cold discomfort occurred. This implies a possible use of fingertip temperature as a control signal for personalized heating. Wang et al. measured in their experiments the skin temperature by thermocouples attached directly to the body. However, for practical application it is necessary to measure the skin temperature in a way that does not hinder an overall comfort of the users.

Since the hands are in an office usually directly exposed to the environment, it is possible to measure the fingertip temperature by an infrared thermography. However, using infrared thermography arises a challenge how to track a moving finger. This paper introduces and discusses a method based on pattern matching for real time tracking of hand movement in an infrared image.

2 Methods

2.1 Thermal chamber experiments

In order to test a feasibility of using a remotely sensed fingertip temperature as control signal for personalized heating a human subject experiment was set up in the climate chamber at Eindhoven University of Technology.

Six subjects (five male and one female) performed a normal office work. The workplace was equipped with a laptop with external monitor, keyboard and mouse. The subjects were exposed for two hours to a uniform thermal environment with operative temperature of 18 °C. The conditions were designed as slightly cool to cool (predicted mean vote of -2 to -1).

Every fifteen minutes the test subjects were filling a questionnaire regarding their overall and local thermal comfort and sensation.

2.2 Thermal imaging

In this study we used a thermocamera Flir ThermaCAM S65HS to remotely measure the fingertip temperature. Specification of the camera are given in Table 1. The camera was placed on a stand above the computer monitor in a distance of 1.5 m from the keyboard. A thermal image of the desk area with the keyboard and mouse was taken every five seconds.

Table 1 ThermoCAM S65HS specification

Field of view/min focus distance	20° x 15° / 0.3 m
Spatial resolution (IFOV)	1.1 mrad
Thermal sensitivity	50 mK at 30° C (86°F)
Detector type	Focal plane array (FPA) uncooled microbolometer; 320 x 240 pixels
Spectral range	7.5 to 13 μm

2.3 Pattern matching

For the finger tracking we developed an algorithm based on pattern matching in LabVIEW (National Instruments 2014). Figure 1 shows an example of pattern matching in a static image – after a pattern is taken the algorithm finds similar areas in the whole image.



Figure 1 Pattern matching in a static image (from left: source image, marked pattern, matched patterns)

The pattern matching algorithm for real time finger tracking works in following steps:

1. The templates as shown in Figure 2 are searched for.
2. The matched patterns are sorted by maximum temperature in each match.
3. The matched pattern with the highest maximum temperature is chosen as the correct match of fingertip and the algorithm returns this temperature. This step is based on assumption that the background of an infrared image is colder than the fingertip.
4. In case of no matched pattern the algorithm returns default temperature of 30 °C.
5. The fingertip temperature is averaged of last 12 values (moving average). This is done to lower the fluctuations of measured value in case of false detections.



Figure 2 Finger template images

A block diagram of the tracking algorithm is given in Appendix.

3 Results & Discussion

Figure 3 presents a comparison of the fingertip temperature as measured by the tracking algorithm and post processed for one test subject. The post processed values were carefully read from the infrared images after the experiments for every 15 minutes of the two hours exposure. The fingertip temperature as measured by the tracking follows the post processed temperature within ± 2 °C until the fingertip drops under 30 °C. Similar trend was observed for all the test subjects. It was also observed that, when the temperature continues dropping, the number of false or no detection greatly increases and the tracking algorithm cannot reasonably follow the fingers anymore. This is caused by the loss of contrast in the image because the fingertip temperature is getting closer to the temperature of background.

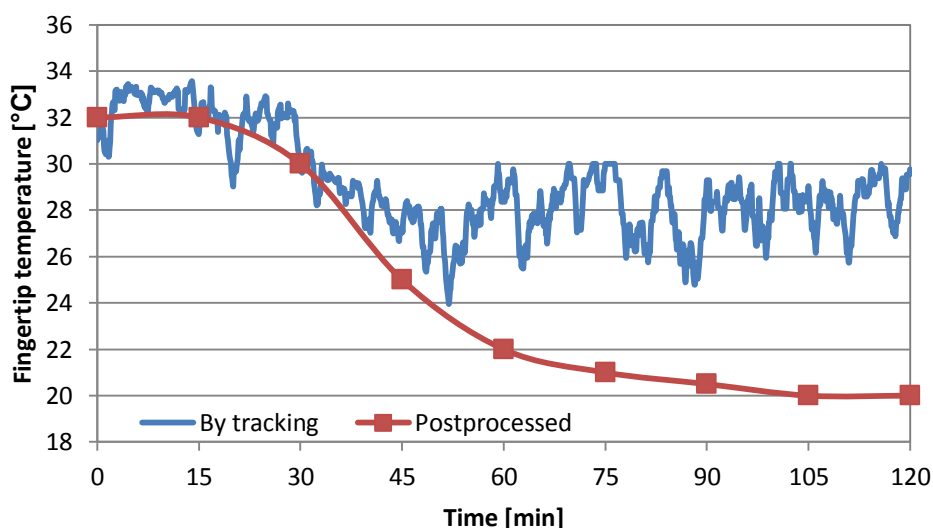

Figure 3 Fingertip temperature as measured by tracking algorithm and post processed (one test subject)

Figure 4 shows fingertip temperature (post processed values) and overall thermal sensation during two hours exposure as averaged for all six test subjects. Thermal sensation correlates with fingertip temperature with R^2 value of 0.93. Thermal sensation can thus be reasonably

predicted by fingertip temperature under assumptions of our study (mild cool thermal conditions).

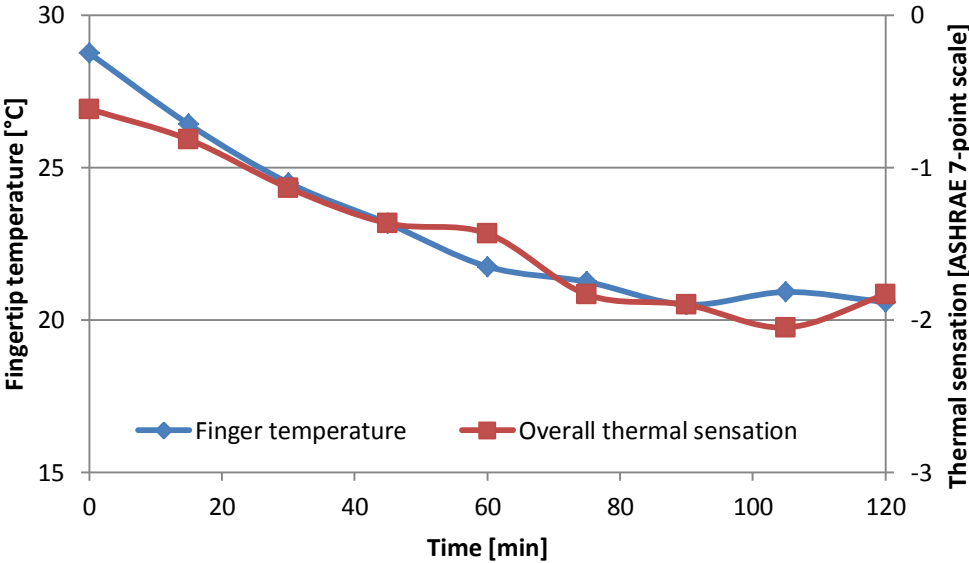

Figure 4 Thermal sensation and fingertip temperature (average for all six test subjects)

A comparison of our study with the study of Wang et al. (2007) is shown in Figure 5. Each of our data points, shown as yellow empty squares, represents one subjective response of one subject with corresponding fingertip temperature (post processed value). Although Wang et al. used a slightly different thermal sensation scale (extended ASHRAE 7-point scale) and different measuring technic, the data of both studies shown a good agreement. The data points that represent a risk of cold discomfort cluster mostly under the fingertip temperature of 30 °C and thermal sensation under neutral.

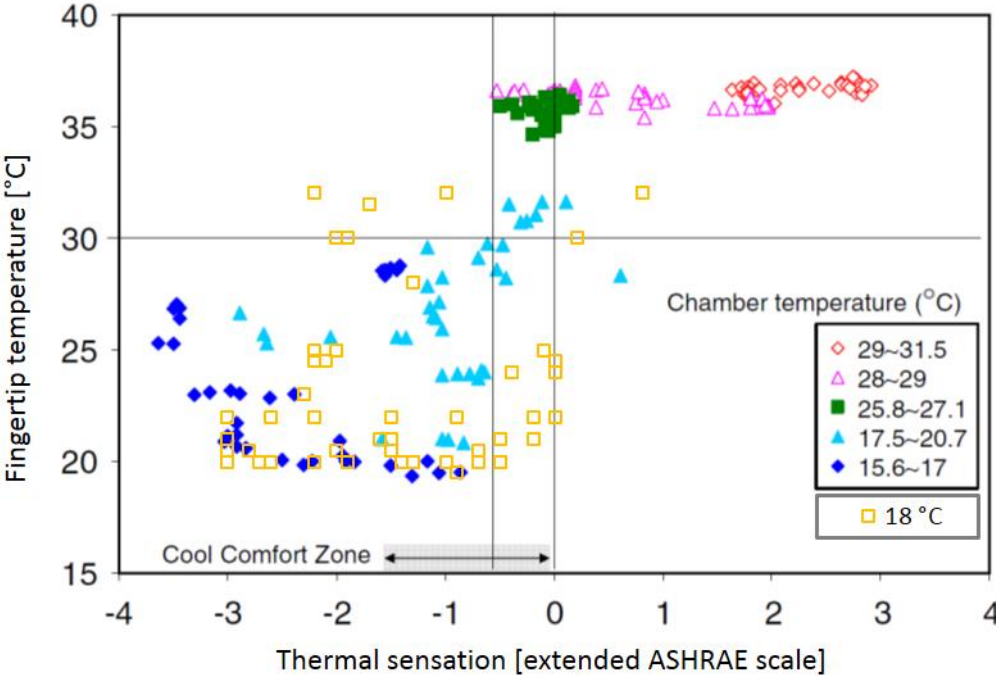

Figure 5 Comparison of our study with the study of Wang et al. (2007), our data are represented by yellow empty squares, adapted from (Wang et al. 2007)

4 Conclusions

The method for finger tracking in an infrared image has been presented in this paper. This method can reasonably track the fingers, when the fingertip temperature is above 30 °C, which ensures thermal comfort, and the background temperatures are within a normal indoor temperature range. These criteria are presumably fulfilled for an intended application of this measuring method, which is using the fingertip temperature as a control signal for a local heating.

5 Limitations and future research

The tracking algorithm as presented in this paper is limited to relatively narrow range of temperatures that normally occur in an office environment. As the intention is to use the fingertip temperature as a control signal for personalized heating, it is needed to study how the finger can be tracked, if a hand heating mat or a radiation heating focused on hands is applied.

In our study we used a very sophisticated and expensive thermocamera. It is needed to use a low cost infrared array in order to make a control method based on remotely sensed temperature available for wide range of customers. However, a low resolution of a simple infrared array may not allow for a finger tracking. This problem can be solved by coupling the infrared array with an optical camera used for tracking.

References

- Foda, E. & Sirén, K., 2012. Design strategy for maximizing the energy-efficiency of a localized floor-heating system using a thermal manikin with human thermoregulatory control. *Energy and Buildings*, 51, pp.111–121. Available at: <http://linkinghub.elsevier.com/retrieve/pii/S0378778812002320> [Accessed May 22, 2013].
- Melikov, A.K., 2004. Personalized ventilation. *Indoor Air*, 14(s7), pp.157–167. Available at: <http://europepmc.org/abstract/MED/15330783/reload=2;jsessionid=CAVOg2AU68zRaIJUTthW.16> [Accessed January 30, 2013].
- Melikov, A.K. & Knudsen, G.L., 2007. Human response to an individually controlled microenvironment. *HVAC&R Research*, (February 2013), pp.37–41. Available at: <http://www.tandfonline.com/doi/abs/10.1080/10789669.2007.10390977> [Accessed February 14, 2013].
- National Instruments, 2014. NI LabVIEW - Improving the Productivity of Engineers and Scientists - National Instruments. Available at: <http://sine.ni.com/np/app/main/p/docid/nav-104/lang/nl/> [Accessed February 7, 2014].
- Wang, D. et al., 2007. Observations of upper-extremity skin temperature and corresponding overall-body thermal sensations and comfort. *Building and Environment*, 42(12), pp.3933–3943. Available at: <http://linkinghub.elsevier.com/retrieve/pii/S0360132306003647> [Accessed February 6, 2013].
- Watanabe, S., Melikov, A.K. & Knudsen, G.L., 2010. Design of an individually controlled system for an optimal thermal microenvironment. *Building and Environment*, 45(3), pp.549–558. Available at:

<http://linkinghub.elsevier.com/retrieve/pii/S0360132309001851> [Accessed February 11, 2013].

Appendix

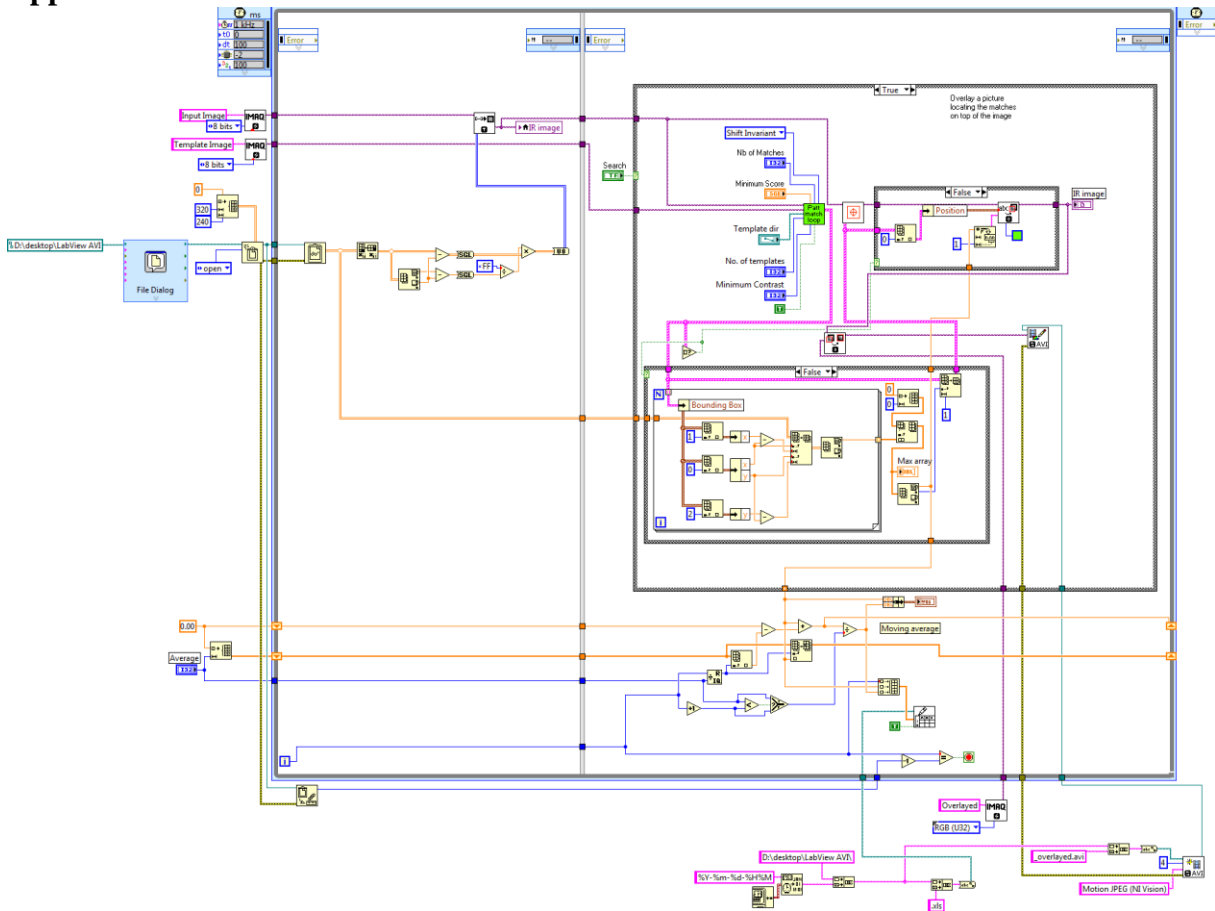

Pattern matching algorithm for real time finger tracking – block diagram

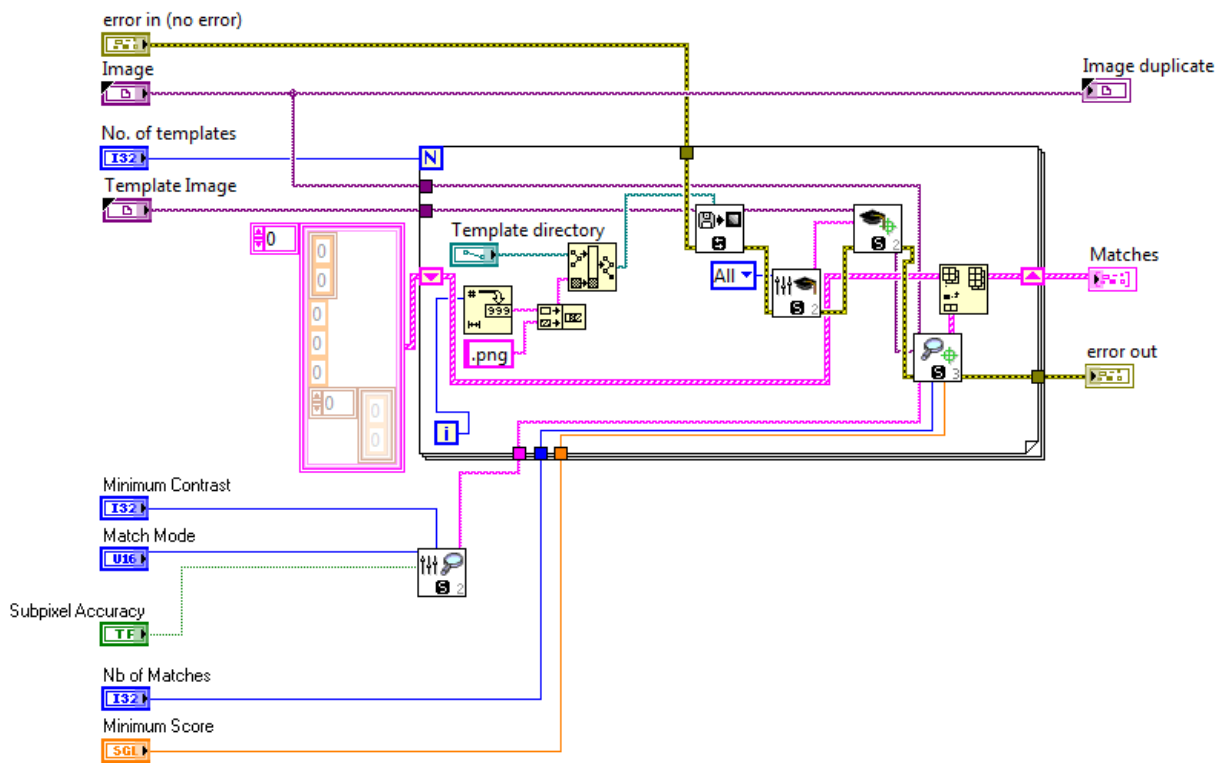

“Patt match loop” block from Pattern matching algorithm

Field Study of Thermal Environment Acceptability Using Ostracon Voting Device

Masanari Ukai¹, Yuta Ichikawa² and Tatsuo Nobe³

1 Kogakuin University, Tokyo, Japan, dm12011@ns.kogakuin.ac.jp

2 Kogakuin University, Tokyo, Japan, dm13003@ns.kogakuin.ac.jp

3 Kogakuin University, Tokyo, Japan, nobe@cc.kogakuin.ac.jp

Abstract

This study aims to assess the thermal conditions of an indoor environment deemed unacceptable by workers. For this purpose, Ostracon, a voting device, was developed to record the physical environment at the time a worker presses a button to express a complaint. Ostracon was used to record the opinions of 90 workers about their thermal environment in six offices during the summer. The results show that workers found the indoor thermal environment unacceptable even when the static thermal conditions were within a range that was predicted to be comfortable. Moreover, most of the workers' complaints were expressed moments after returning from tasks performed outside the office. This suggests that the workers' complaints were influenced by factors other than the indoor environment such as thermal history.

Keywords: Acceptability, Thermal comfort, Ostracon, Workplace, Thermal environment

1 Introduction

Thermal comfort is a topic under considerable debate because of the rapid progression of air-conditioning technology. The thermal index of the American Society of Heating, Refrigerating and Air Conditioning Engineers (ASHRAE) uses two pairs of antonyms: 'hot-cold' and 'warm-cool.' However, such nomenclature is problematic in Japanese; ASHRAE describes 'warm' and 'cool' environments as uncomfortable for daily living, but such environments are sometimes considered comfortable in Japan. Moreover, 'neutral' is not always comfortable. The results of a 1975 survey conducted by ASHRAE showed that no single thermal environment satisfied all respondents. Therefore, the environmental condition and physiology referred to as 'neutral,' rather than 'warm' or 'cool,' was determined by ASHRAE as the definition of comfort. Currently used air-conditioning systems improve the thermal comfort of the indoor environment on the basis of this concept. The two indices typically used to evaluate thermal comfort, predicted mean vote and standard new effective temperature, evaluate only the steady states of thermal sensation. The index of predicted percentage of dissatisfaction based on the predicted mean vote is used to evaluate the steady-state environment. Such a restriction is problematic because in reality, the indoor thermal environment is evaluated on the basis of the acceptance of office workers, as expressed through complaints, and there is no established index to evaluate this acceptability. This study aims to clarify the mechanism to determine in the case of workers consider the thermal environmental acceptable in an actual office. This paper shows the characteristics of the complaints of actual workers as shown by data captured by Ostracon, which is a voting device developed to record the physical environment at the time a worker presses a button to

express a complaint. Furthermore, the study examines the process by which a worker determines whether a thermal environment is acceptable.

2 Ostracon device

The term ‘Ostracon’ originated in ancient Greece and describes a shard of pottery used by voting public to prevent the election of a dictator. The authors adopted this name for an acceptability-voting device developed for the present study to record the conditions of the physical environment deemed unacceptable by workers. The specifications of Ostracon are summarized in Table 1. Workers can push a button on the device located on their desks to record a complaint when they feel that the thermal environment is unacceptable. The Ostracon sends a signal to a pulse recorder when the button is pressed, activating the attached thermo-recorder and humidity recorder.

Table 1. Ostracon device used to vote on acceptability of the environment.

Acceptability-voting device	
Appearance	
Installation	Personal desk
Report of condition	Unacceptable
Measurement interval	10 min
Size	H 100 mm × W 70 mm × D 50 mm

Ostracon was used to determine whether the subjects deemed the environment comfortable in six offices during the summer. The conditions for each measurement location are shown in Table 2. The distribution of the types of job and preset temperature of the air-conditioning system differed for each office. Five workers of Office M each carried a pedometer to record their movement during this study.

Table 2. Conditions for each measurement location.

Office name	Term	Outdoor air temperature [°C] [Maximum]	Number of subjects	The type of job
S	2012/23/7 to 2012/6/8	35.4	10	Technical × 7, Clerical × 3
E	1 : 2012/8/8 to 2012/14/8	34.5	10 × 3	Technical × 12, Sales × 10 Clerical × 5, Administrator × 3
	2 : 2012/16/8 to 2012/22/8	35.7		
	3 : 2012/24/8 to 2012/30/8	35.6		
O	1 : 2012/7/30 to 2012/8/9	34.7	10 × 2	Research × 13, Clerical × 4 Technical × 1, Unknown × 2
	2 : 2012/8/21 to 2012/8/30	35.6		
T	2012/21/8 to 2012/17/8	35.6	10	Technical × 7, Clerical × 2 Unknown × 1
R	2012/6/9 to 2012/18/9	32.5	10	Technical × 9, Clerical × 1
M	2012/13/9 to 2012/10/10	32.5	10	Technical × 5, Clerical × 4 Unknown × 1

3 Results

3.1 Indoor thermal environments of offices

Fig. 1 shows the data from ASHRAE Standard 55-2004 within the indoor thermal environment in each office during operational hours. The environmental temperature was ascribed to the operative temperature because Ostrakon cannot measure the radiation temperature. The shaded areas in the figure indicate the indoor thermal environments during office hours. The dashed red lines indicate the area within the comfortable temperature–humidity range in summer. The preset temperature and humidity set by the air-conditioning system differed for each office. The temperature and humidity were preset at a higher level than usual due to brownout restrictions set in the aftermath of the Great East Japan Earthquake.

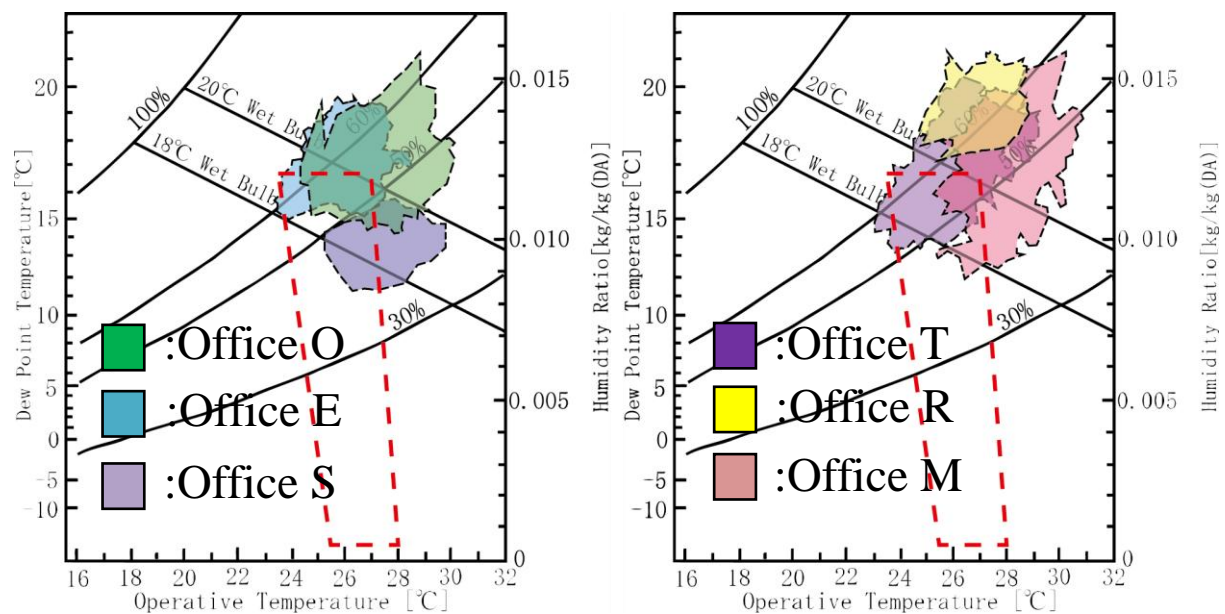

Figure 1. Indoor thermal environments of each office during operational hours.

Fig. 2 shows the occurrence frequency of the temperature and humidity in each office during operational hours. Office S used a ceiling radiant cooling system and desiccant air-conditioning unit. Therefore, its preset humidity was low. The humidity in Office R was high because it lacked dehumidification from a variable refrigerant flow system.

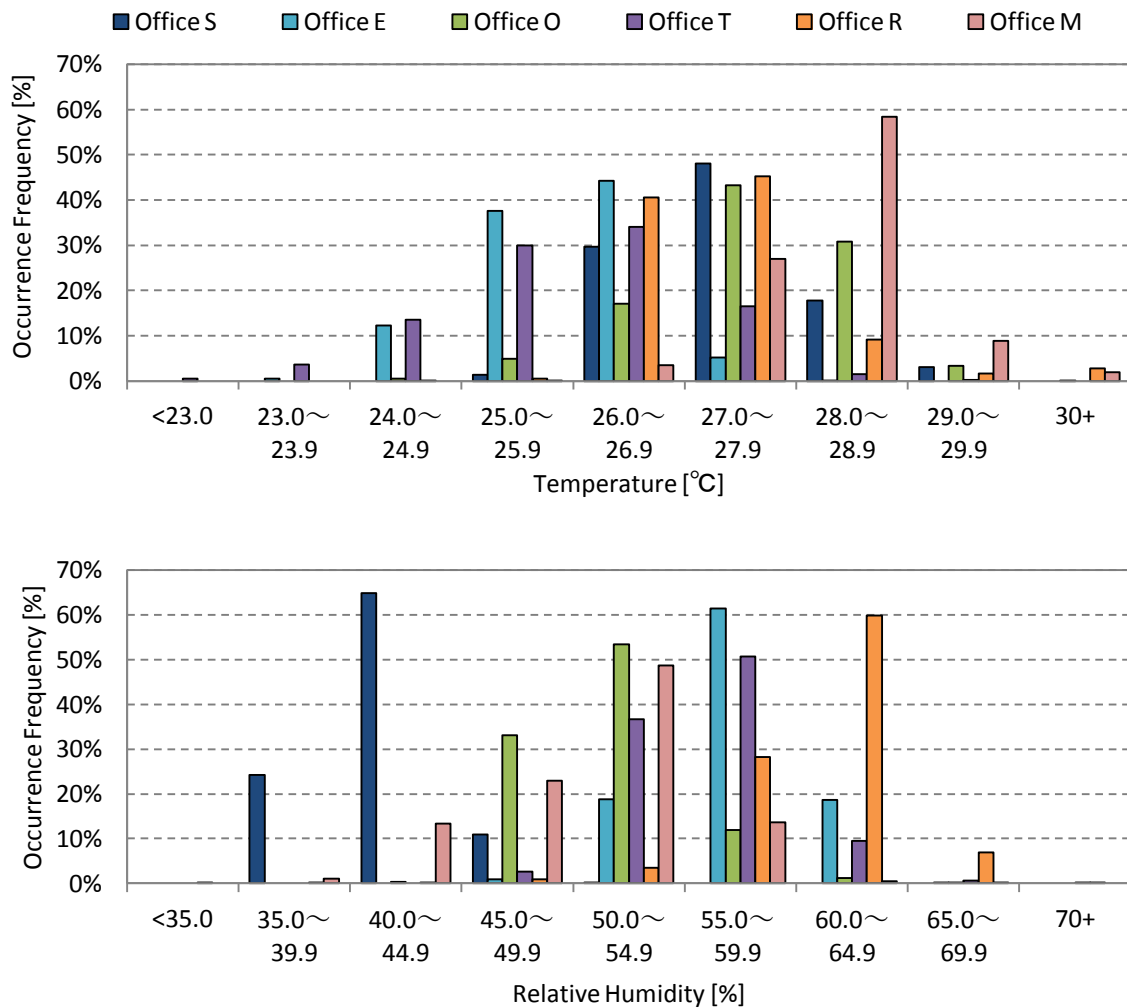

Figure 2. Occurrence frequency of the temperature and humidity in each office during operational hours.

3.2 Trend in the number of votes indicating unacceptable environment

Fig. 3 shows a decreasing trend in the number of votes indicating an unacceptable environment during the five days after the installation of Ostracon at each office. The number of votes indicating an unacceptable environment showed a decreasing trend during the five days. The data captured during a national holiday and a weekend were excluded. Moreover, because less than five days of data were recorded from Office E-1, these data were also excluded. Fig. 4 shows the predicted voting cumulative frequency according to the Gompertz curve and the voting cumulative frequency per worker at Office T. The voting cumulative frequency predictor by the Gompertz curve is

$$, (1)$$

where K , a and b are estimators of a parameter from the actual measured value, and x is the number of elapsed days. The results show that the number of votes deeming the environment as unacceptable was uniform during the first 10 days and showed a decreasing trend during the next nine days. A possible explanation for this behaviour is that the workers were likely

more interested in Ostracon at the beginning of the survey and the votes decreased as workers grew accustomed to their environments. However, this study was the first survey of using ostracon. Also, the decreasing trend of number of unacceptable votes was different with each worker. Therefore, the data were analyzed without considering such subjective human behaviour, and the data from Ostracon for Day 1 were analyzed.

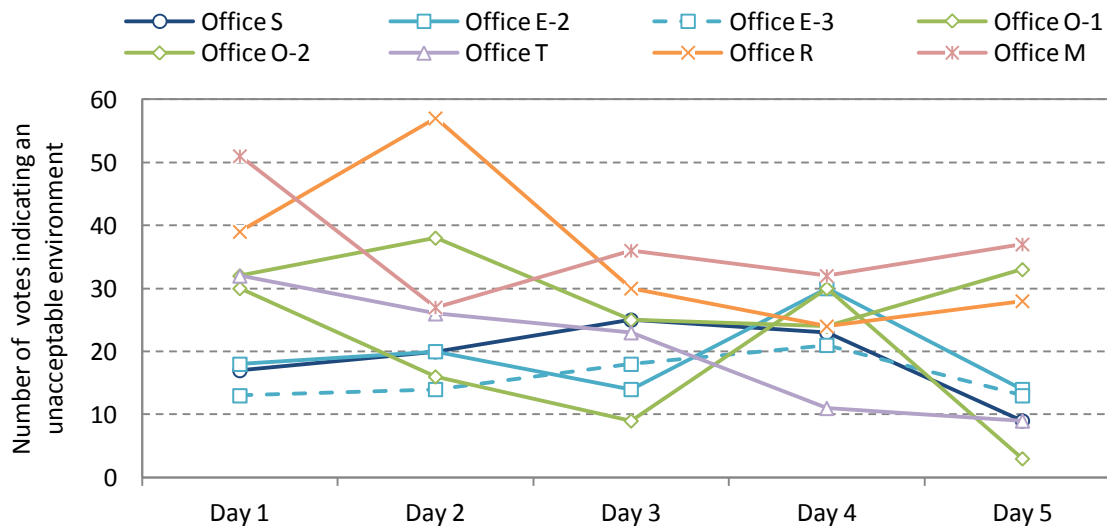

Figure 3. Changes of in the number of votes indicating unacceptable environment during the five-day period after the installation of Ostracon.

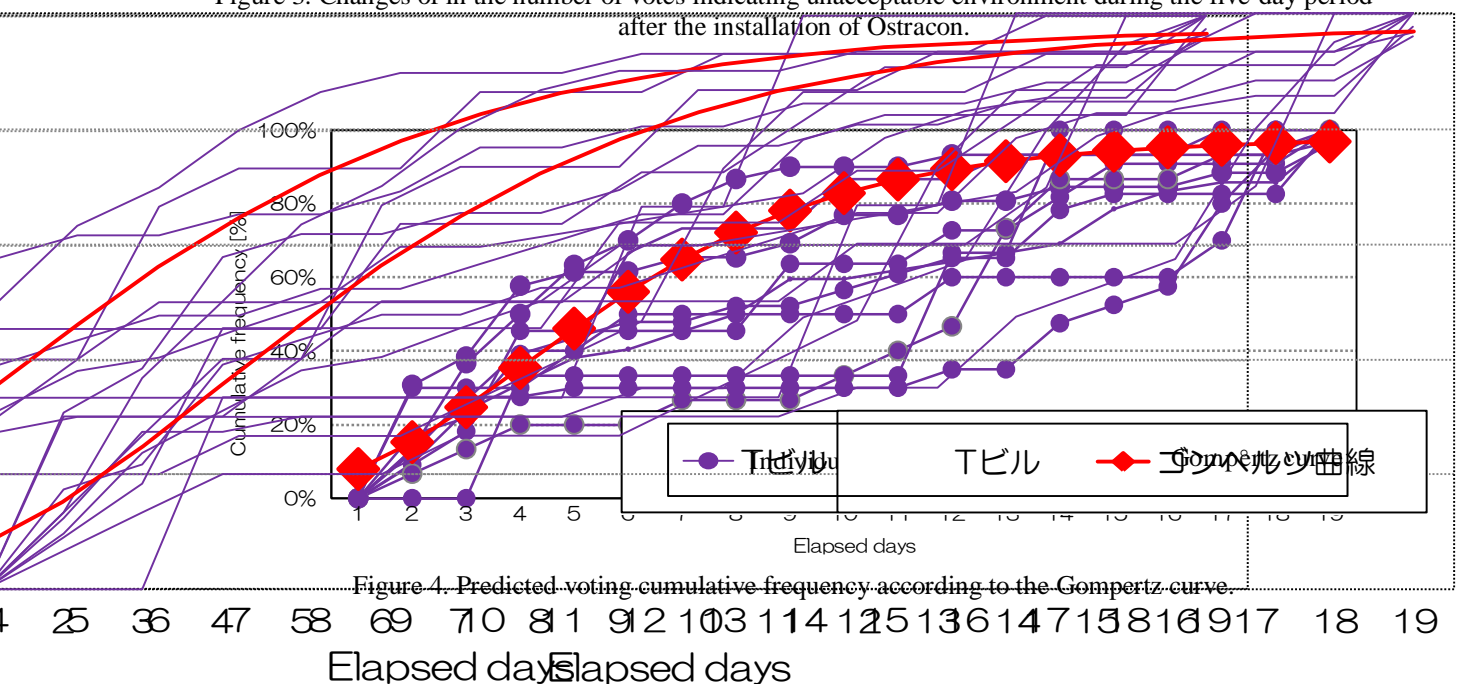

Figure 4. Predicted voting cumulative frequency according to the Gompertz curve.

3.3 Typical example of unacceptable votes

Fig. 5 shows the typical example of votes indicating unacceptable thermal environment at Office T. The dashed lines show the data for field workers and the continuous lines show the data for non-field workers. The results show that the number of votes indicating an unacceptable environment was different each day. The dashed lines in the figure show that a large number of votes came from field workers. Therefore, it is considered that the workers' complaints were influenced such as changes in their metabolic rates and personal sequence of thermal environment.

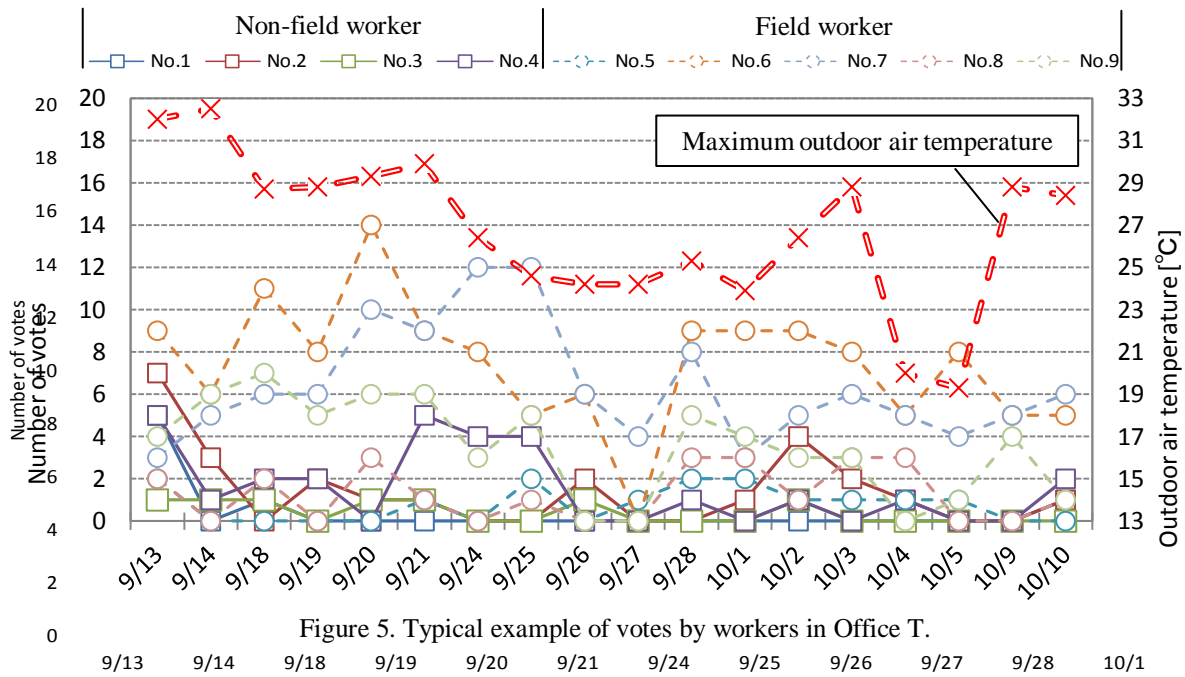

Figure 5. Typical example of votes by workers in Office T.

3.4 Temperature–humidity range deemed unacceptable

Fig. 6 shows the data based on ASHRAE Standard 55-2004 indicating the temperature and humidity range deemed unacceptable in each office. The environmental temperature was ascribed to the operative temperature because Ostrakon cannot measure the radiation temperature. The shaded areas in the figure indicate the indoor thermal environments during office hours. The red dashed lines indicate comfortable temperature–humidity ranges in summer. These results show that 1599 votes indicated an unacceptable environment. Although the preset temperature and humidity differed among offices, 23.3% of the temperature and humidity values recorded in all offices were within the range deemed comfortable as per the ASHRAE Standard 55-2004.

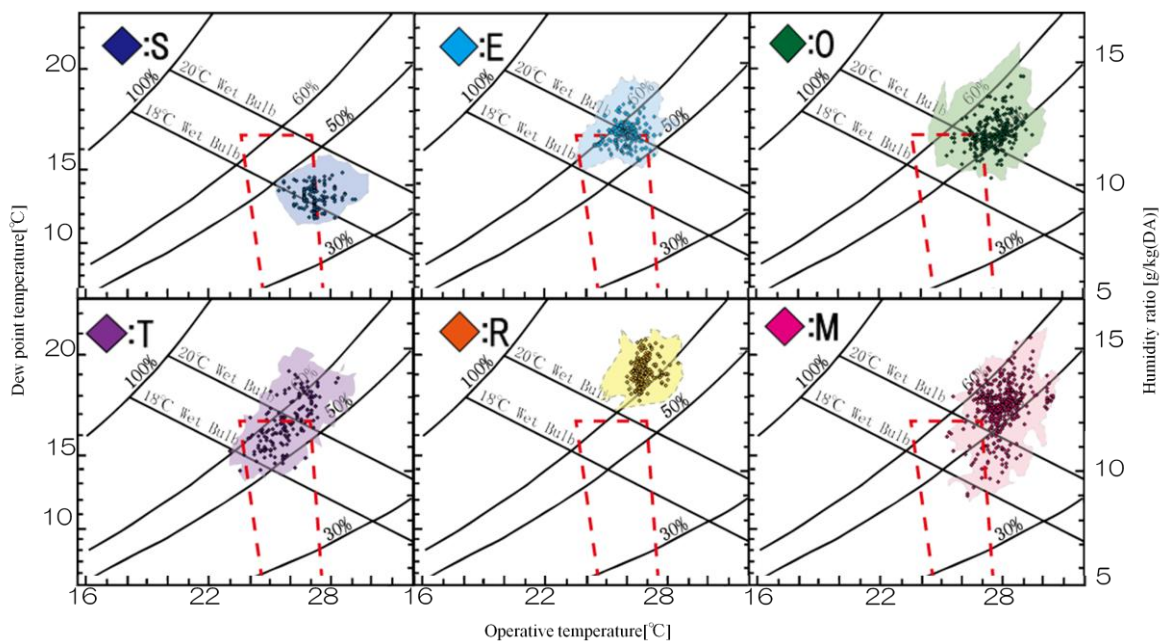

Figure 6. Votes indicating unacceptable environments and comfortable temperature–humidity ranges (ASHRAE Standard 55-2004).

3.5 Occurrence frequency of the temperature at which the environment was deemed unacceptable

Fig. 7 shows the occurrence frequency of the temperature deemed unacceptable by the workers. Dashed lines in the figure indicate the occurrence frequency of the temperature during office hours on the desk by ostrakon. In these results, the occurrence frequency of the votes indicating unacceptable environment is similar to that of the temperature during office hours. Therefore, the data do not show a relationship between the temperature and acceptability of the thermal environment.

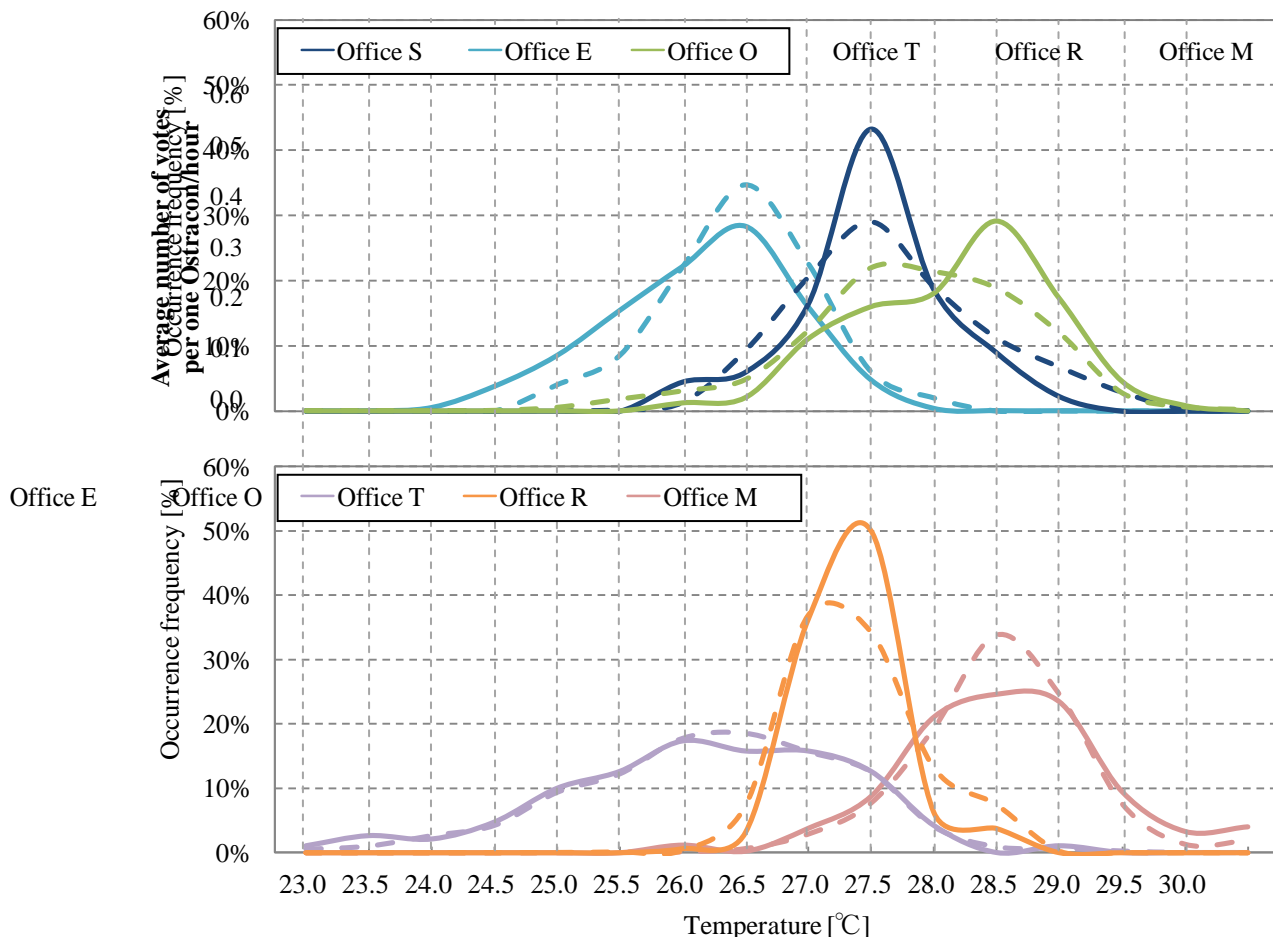

Figure 7. Occurrence frequency of the temperature at which the environment was deemed unacceptable by the workers.

3.6 Specific enthalpy and unacceptable votes

Fig. 8 shows the relationship between the specific enthalpy at the time someone voted unacceptable environment and the specific enthalpy difference 10 min prior to the voting. In general, when a thermal environment continues to improve, individuals deem the thermal environment comfortable. However, in these results, the votes indicating unacceptable environment occurred independently of the specific enthalpy difference 10 min prior to voting in the actual office environment. Therefore, it is considered that thermal environmental acceptability is not determined simply by physical environment conditions.

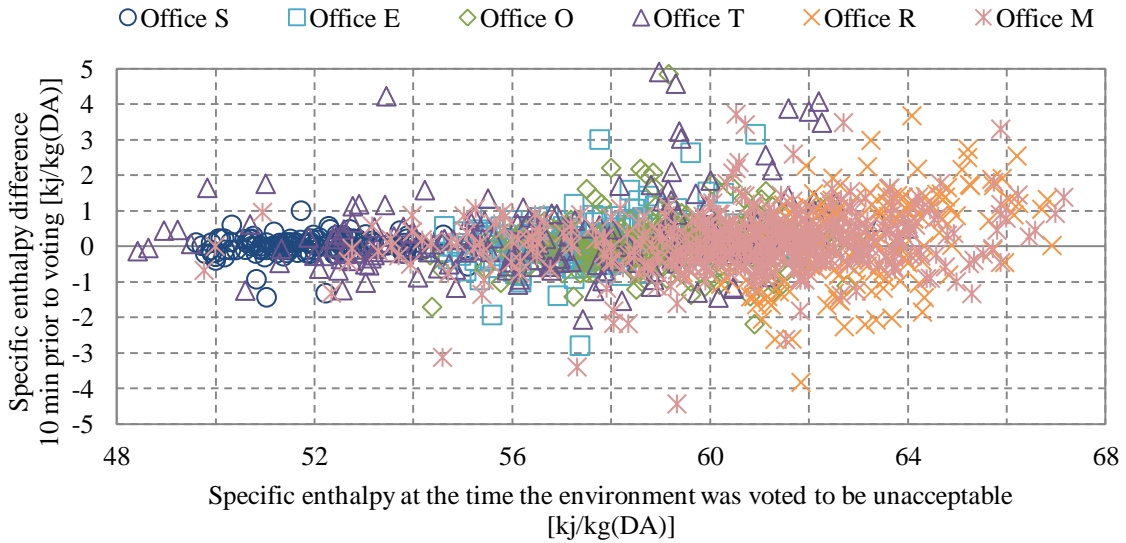

Figure 8. Specific enthalpy at the time of unacceptable votes.

4 Discussion

Fig. 9 shows that the number of votes was affected by the walking distance to Office M. A walking distance of more (less) than 500 metres per hour was assumed to correspond to movement outside of (within) the office. The results show that a high number of votes indicating unacceptable environment was affected by movement outside the office. Fig. 10 shows the average number of votes recorded during each hour at each office. In these results, the votes indicating unacceptable environment were concentrated in the morning and evening. These hours correspond to the times at which workers enter the office in the morning and return back from outside tasks in the evening. These results suggest that workers' complaints about the office environment are affected by changes in metabolic rates, such as those occurring when a worker returns to the office after leaving for lunch or performing job tasks outside of the office.

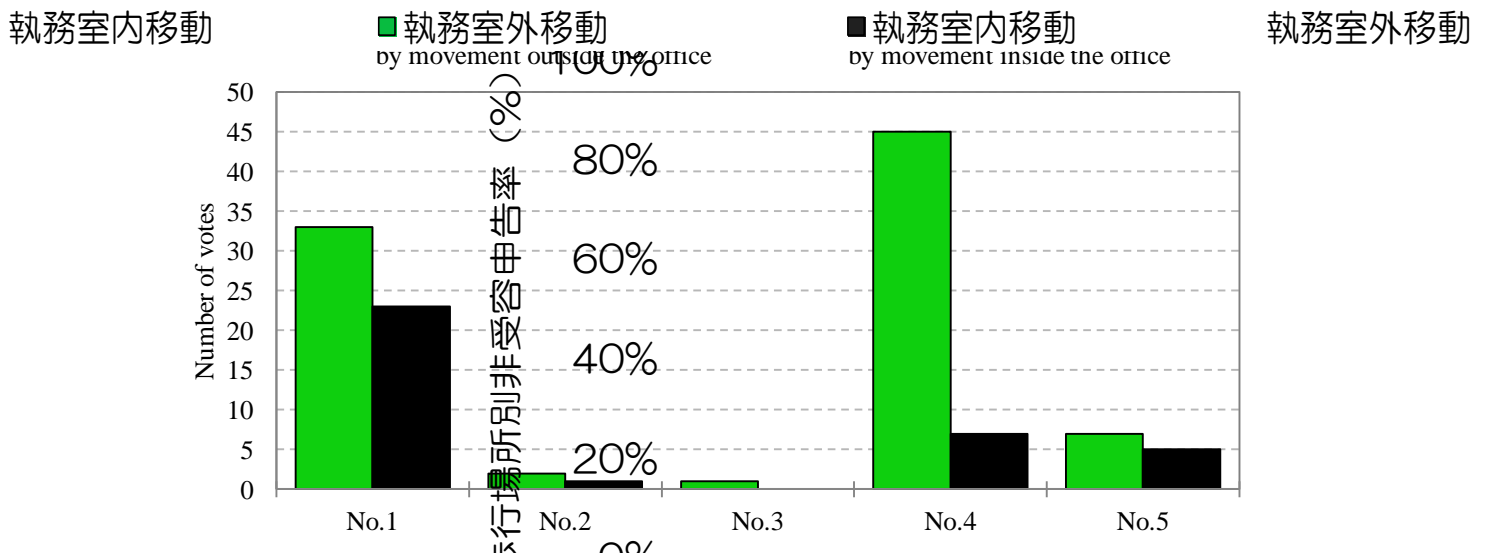

Figure 9. Number of votes affected by walking distance to Office M.

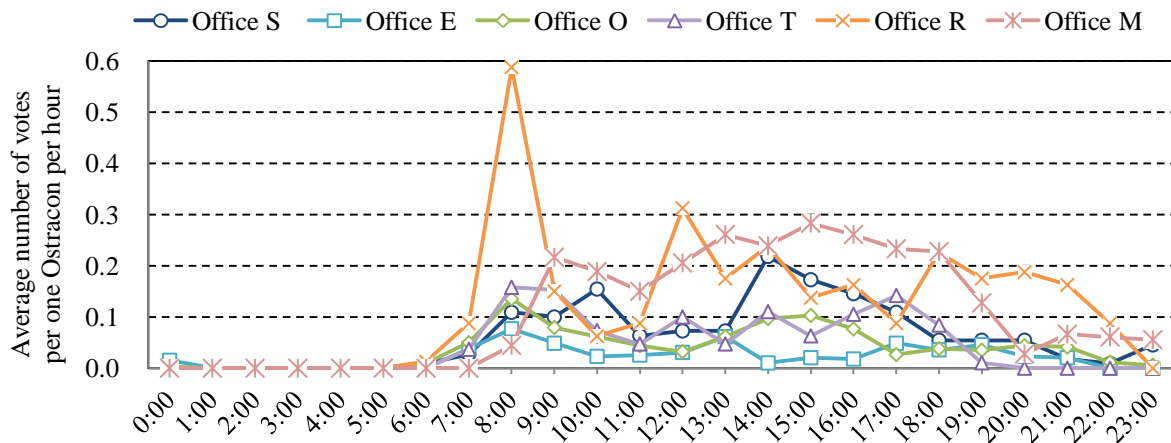

Figure 10. Average number of votes recorded during each hour at each office.

4 Conclusions

This study aimed to clarify the characteristics of the complaints and the mechanism by which workers consider the thermal environment acceptable in an actual office. For this purpose, the authors developed a device called Ostracon that can record the physical environment when the workers feel that the thermal environment is unacceptable. Ostracon was used to record the environmental conditions at the time workers in offices felt the office environment to be unacceptable during the summer. The results are summarized in the following points:

- 1) Votes indicating an unacceptable environment were recorded even when the thermal environment was consistently maintained at comfortable levels according to ASHRAE standards. Even when the environmental conditions were set at a comfortable temperature–humidity range, 23.3% of the votes indicated that the environment was unacceptable.
- 2) The data did not show a relationship between the physical environment and the occurrence of votes deeming the environment as unacceptable. Therefore, it is considered that acceptability of the thermal environmental is not determined simply by temperature and humidity.
- 3) The votes indicating an unacceptable environment were concentrated in the morning and evening. These hours correspond to times at which workers enter the office in the morning or return in the evening from performing tasks outside the office. Moreover, a high rate of unacceptable votes was affected by movement outside of the office.
- 4) Therefore, it is considered that worker complaints registered in this study are a result of environmental factors such as the individual’s thermal history and changes in metabolic rates that result from returning to the office after performing activities outside of the office.

References

- Gagge, A. P., Stolwijk, J. A. J., Nishi, Y., 1971. An effective temperature scale based on a simple model of human physiological regulatory response, *ASHRAE Transactions*, Vol.77, Pt.1, pp 247-262 (in English).
- Kuno, S., et al., 1987. A two-dimensional model expressing thermal sensation in transitional conditions, *ASHRAE Transactions*, Vol.93, Pt.2, pp 396-406 (in English).
- Ukai, M., Nobe, T., 2012. Study on Acceptability in Unsteady Environment. In: *9th International Meeting for Manikins and Modeling of Japan 2012*. Japan, August (in English).
- Ukai, M., et al., 2012. Study on Acceptability in Thermal Environment (Part1) Experimental Consideration on the Process of Acceptability. Summaries of Technical Paper of Annual Meeting, pp 925-928 (in Japanese).
- Ukai, M., et al., 2013. Investigation of Thermal Environmental Acceptability in Offices Using "Ostrakon". In: *11th REHVA World Congress CLIMA of Prague 2013*. Prague, June (in English).
- Ichikawa, Y., et al., 2013. Study on Acceptability in Thermal Environment (Part2) Field Study on Unacceptable of Indoor Thermal Environment Using Ostrakon. Summaries of Technical Paper of Annual Meeting Air-Conditioning and Sanitary Engineers, Japan, pp 61-64 (in Japanese).
- Shinozuka, D., et al., 2006. Research on Task/Ambient Conditioning System (Part31) Results of Seat Occupancy Rate and Traveled Distance in an Office. Summaries of Technical Paper of Annual Meeting Architectural Institute of Japan, Japan, pp 1027-1028 (in Japanese).
- Susan, M., 1982. A Greek Ostrakon from Babylon of the Early Third Century B.C. *ZPE*, Vol.47 , pp 51-70 (in English).

WINDSOR CONFERENCE 2014

COUNTING THE COST OF COMFORT

SESSION 5

Lighting, acoustics and building physics

Invited Chairs: Luisa Brotas and Adrian Pitts

Proceedings of 8th Windsor Conference: *Counting the Cost of Comfort in a changing world* Cumberland Lodge, Windsor, UK, 10-13 April 2014. London: Network for Comfort and Energy Use in Buildings, <http://nceub.org.uk>

On finding balance between collaborative noise and speech privacy in open offices

John Goins¹

¹Research conducted at Center for the Built Environment (CBE); findings completed at Pacific Northwest National Laboratory (PNNL), john.goins@pnnl.gov

Abstract

A growing number of businesses are moving towards open-plan offices as a way of encouraging impromptu collaborative problem solving among workers. However, while collaboration increases in open-plan offices, a commensurate increase in general noise can hinder employees that need quieter conditions to prosper. In this paper, the effects of conversational noise within an open plan environment are quantified, and the degree to which noise restrictions compromise problem-solving examined. Measurements indicate that the noise levels from six people conversing (two conversations) in a 1,300 square foot room were sufficient for collaboration, but were near the boundaries for disturbing those working nearby. This suggests a limit on appropriate densities of spontaneous collaborative talk in open offices. At the same time, concern about disturbing others may have hampered creativity during collaborative talk. Subject surveys also indicated an increase in non-verbal collaboration in later tests, suggesting a willingness from occupants to seek a balance between collaboration and quiet.

Keywords: open-plan, collaboration, office design, speech privacy, building performance

1 Introduction

There has been a recent shift away from enclosed offices towards open plan designs. Around 70% of office workers now sit in open-plan offices ([IFMA 2010](#)). These kinds of spaces remove the dividing walls between workstations, and instead provide minimal separation between each employee, as a way to promote interaction. These spaces are believed to encourage impromptu conversations, which in turn, makes collaborative problem solving easier.

The use of open plan offices to encourage innovative and collaborative problem solving is perhaps a good one. One study suggests that more than 80% of office workers prefer engaging in casual conversations over more formal meetings ([GSA 2006](#)). However, the decreased amount of separation between people and more talking in open plan offices also leads to more office noise. The lack of acoustic separation in open offices especially allows conversational noise to travel. Surveys have shown that over 50% of open-office workers are irritated by the inability to conduct private conversations and the inability to avoid overhearing the conversations of others ([Jensen, Arens et al. 2005](#)).

In general, there is discomfort with the lack of privacy found in open-plan offices, as

well as concern over the reduced productivity and job satisfaction they may cause (Oommen, Knowles et al. 2008). Noise spill-over affects those attempting to do focused work, as reported in several surveys of office workers (Hedge 1982, Inalhan 2003). Laboratory studies have also shown that office background noise, with and without speech, lead to poorer performance in mental recall and arithmetic tasks (Perham, Hodgetts et al. 2013). Additionally, many workers simply prefer privacy over increased intra-group accessibility (Sundstrom, Burt et al. 1980, Baldry and Barnes 2012). While employees may approve of the increased communication available in open-office plans, a lack of privacy may make them prefer closed environments (Davis 1984).

Clearly then, balance is needed to maximize the value of impromptu collaborative conversation and that of focused work. Finding this balance requires an understanding of the level of noise produced by people working together on a problem, and how restrictions to noise alter the collaborative dynamic. This study examines both issues.

2 Data and Method

The study was performed in a ‘collaboration hall’, at a US junior college. This hall sits in a quiet section of campus, away from large roads and other significant sources of outdoor noise. The hall was designed to encourage student collaboration and was intended for use by up to 100 students. The hall itself is approximately 1,300 square feet (120 square meters). The size and capacity of this hall make it a good proxy for an open plan office space.

Acoustic measurements were performed both when the hall was empty and while occupied. The baseline measurements, taken when empty, were completed with all windows closed and with the mechanical system operating in a typical fashion. Measurements were also taken from a random interval during the problem-solving process under whispering and normal speech conditions; Table 1 shows the acoustic conditions as measured for this study.

Table 1: Acoustical conditions tested in this study.

Test No.	Working Environment	Communication level	Distance between groups
1	Open	Whispering only	At least 5ft (1.5m)
2	Open	Normal	At least 5ft
3	Semi-shielded	Normal	At least 5ft
4	Open	Normal	Less than 5ft

The baseline measurements were compared to the whispering and talking conditions. A difference of 15dB(A) or greater between the two is suggested when the goal is to hear and understand (ANSI/ASA). This might constitute an optimal condition for workers engaged in collaboration. These same conditions however, would likely disturb those workers needing quiet.

Six volunteers were chosen for the purposes of this experiment, consisting of both

males and females. Each volunteer was given a survey to determine their openness to collaborative talk. The survey is based on the 'Big Five' personality traits: extraversion, agreeableness, conscientiousness, neuroticism, and openness. Optimal values for collaborative work are approximately 3 for extraversion, with 5 each for agreeableness and conscientiousness ([Buchanan1998](#)). Results from this survey are shown in Figure 1, and indicate that all subjects displayed characteristics consistent with a moderate aptitude for collaborative work.

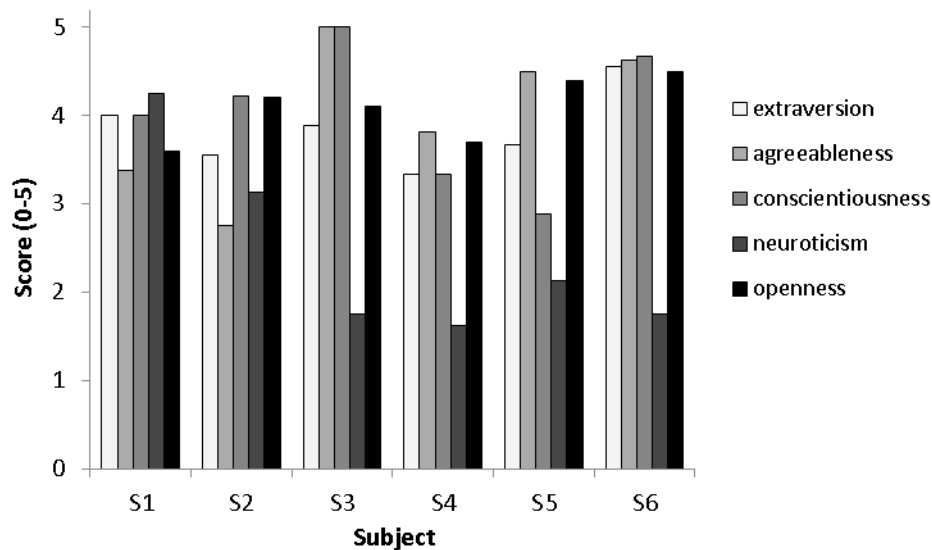

Figure 1: Personality scores of volunteers using the Big Five axes of extraversion, agreeableness, conscientiousness, neuroticism, and openness. All subjects displayed characteristics consistent with the ability to work in a collaborative manner.

Participants were divided into two groups of three, and assigned a task to solve together. The problem, construction of a 3D puzzle, was challenging but no formal instructions were given as a way to maximize casual collaboration. Participants spoke in a conversational manner, often in tandem. It was rare for more than three participants to speak at once. Following each problem solving period, one subject was swapped between groups to randomize the group dynamics. Four conditions were tested as shown in Table 1; allowing the investigation of open vs semi-shielded environments, whispering versus normal communication, and close versus separated groups.

3 Results

The values obtained from the acoustics measurements are shown in Figure 2. Whispering between subjects raised the noise levels above 60 dB(A). The talking condition produced levels above 70 dB(A). A reading of 15 dB(A) over the background noise level would likely disturb nearby workers according to ANSI/ASA standards. The difference between the talking and background conditions is 14.8 dB(A). Thus, the talking condition (two conversations per 1,300 square feet) represents the limit for disturbance of nearby workers. Note that these results were achieved with higher background noise levels than are recommended by ASHRAE and from six subjects in a room designed for 100 people.

A similar sized room in an office building might hold 40 to 50 people. Still, this number of people could possibly produce more than two conversations at a time.

After all conditions had been tested, the volunteers were surveyed to determine their impressions of each condition, focusing predominantly on the ease of collaborative problem solving, and the level of distraction afforded by each condition (Fig 3). Noise levels did not appear to interfere with the functional aspects of collaboration, such as understanding other group members; however, overall satisfaction with noise levels was ambivalent. This suggests that noise was less problematic when directly engaged on a task, although it should be kept in mind that satisfaction would likely decrease in the presence of larger numbers of co-workers.

Figure 2: Noise levels measured during problem solving attempts. The plot indicates the 95 percentile, max and minimum encountered during 30 seconds of measurement. 'Recommended' levels are the preferred background levels for open offices without sound masking according to the ANSI/ASA standards. The sound levels within the grey region would likely not disturb nearby workers.

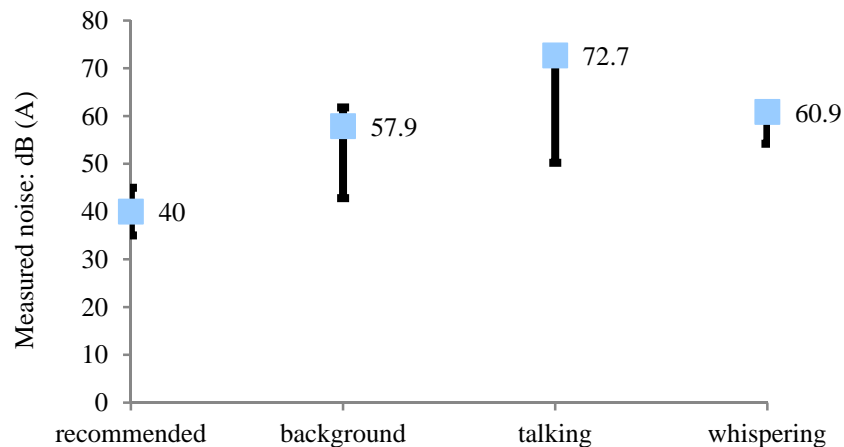

As well as measuring their agreement with set statements, subjects were asked for commentary on their ability to perform the task; selected comments are included in Table 2. Interestingly, while the requirement to whisper did not appear to change subjects' impressions of noise levels or understanding very much, their comments suggested other concerns. Subjects felt that the requirement to be quiet held them back from conversation that was not immediately necessary in an effort to minimize the amount of noise produced. This may have had the unintended consequence of hampering effective collaboration, with consequences for a more fully occupied space.

Figure 3: Results from subject impressions on noise levels. Agreement with the statements indicated was rated on a scale from 1 (strongly disagree) to 5 (strongly agree). Bars indicate average response for three different situations.

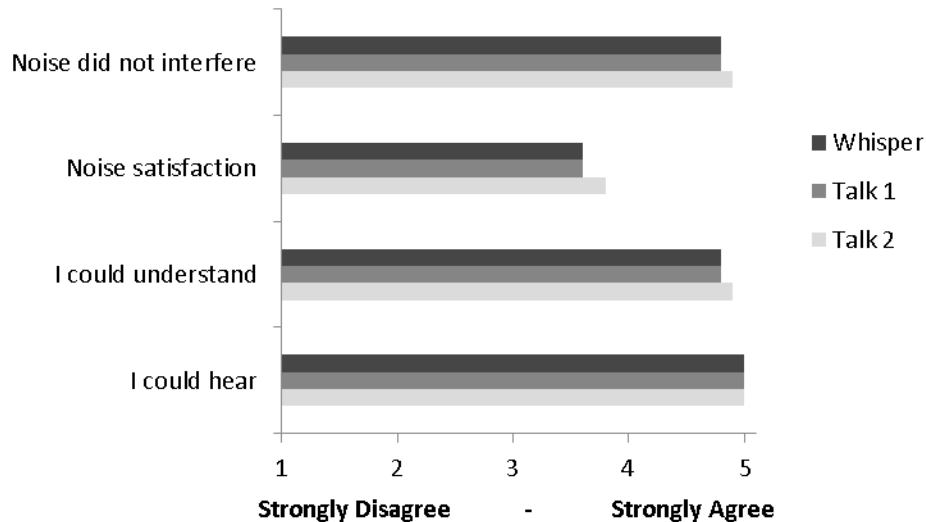

‘I thought I was open to anything until I couldn’t talk’
 Concern about ‘being loud’ hampered creativity.
 ‘I was interested in what others were saying, which was distracting’
 ‘I didn’t need to talk to my teammates much’

Table 2: Selected commentary from subjects completing puzzles under various conditions.

4 Analysis

The noise levels produced from more than two normal collaborative conversations would likely bother nearby workers in an open office. Note that the space where the study took place was designed for 100 people. Current open-plan offices are designed for tens to hundreds of people as well, and this corresponding increase in noise can quickly overwhelm worker concentration and hamper the effectiveness of collaborative interactions. Indeed, a study by the Center for the Built Environment indicated that over 50% of cubicle dwellers believed that acoustics negatively affected their productivity ([Jensen, Arens et al. 2005](#)).

Interestingly the results above demonstrated that some noise is not necessarily a distraction when working on set problems; subjects were able to problem solve even when challenged with extra noise sources. Studies have shown that low noise levels can be tolerated in offices; rather that the problem is a lack of acoustic privacy ([Sundstrom, Town et al. 1994](#)). This is the degree to which intermittent noises (phone calls, conversations, etc.) are able to pass between working zones. This lies behind the development of electronic sound masking systems, which provide a steady background sound level to help mask the otherwise much more distracting transmission of speech ([Evans and Johnson 2000](#)). Clearly then, controlling the noise produced by

each worker, and the transmission of this noise between zones, is important to the harmony of the group. This of course, becomes more difficult as office occupancies become denser.

Enforced quietness however, is likely not a good solution since it hampers collaboration. Subject responses indicated that a requirement to remain quiet hampered their creativity, more specifically that they held back from mentioning ideas that were not directly relevant to the task at hand. Unwritten social mores often develop around shared space which, while preventing excessive noise-related distractions, can have a similar detrimental effect on collaboration. An example of this was given in an interview with an academic, who indicated that a specially built collaborative wall (a combination of whiteboard and digital projector) had never actually been used due to fears that this would create too much noise ([Pinder, Parkin et al. 2009](#)).

It should be pointed out that increased collaboration does not necessarily have to result in increased noise levels, as subjects in our groups were rapidly able to solve problems using non-verbal communication skills. It is thus important that organizational and office design processes train and equip workers to collaborate in many ways. The simplest form of non-verbal communication is via office email or instant-message (IM) chat programs, allowing the transmission of text messages between employees within the same group or department. Corporate intranet systems are increasingly incorporating more complex collaborative tools, such as personal employee homepages, group wikis, and live news feeds modeled on the highly successful Facebook. These are highly informal tools that allow for spontaneous problem solving without the problems of increased office noise.

Further developments of chat software that incorporate non-spoken gestures are underway, where each user controls a virtual avatar (a representation of themselves) ([Guye-Vuillème, Capin et al. 2014](#)). Non-verbal cues are vital to effective communication and are currently often expressed in text communication through emoticons ([Fahlman 1982](#)). By allowing more extensive non-verbal communication, avatar systems are able to further improve communication between distant users ([Dodds, Mohler et al. 2011](#)).

Intermediate working environments can retain the benefits of both collaborative open spaces and motivational private areas. Several successful buildings designed for academics, which require both collaborative and individual problem solving skills, combine small private offices for pairs of workers as well as comfortable spontaneous meeting areas for larger discussions ([Pinder, Parkin et al. 2009](#)). This set up is often known as a 'combi-office' and provides greater privacy than the 'mobile office' setup which has also been proposed.

An alternative paradigm is that of the 'mobile office'. In this system, the workplace is divided into a number of zones, ranging from fully open, collaborative areas to conference rooms and quiet regions for individual work. All workers have laptops and wireless access to the internal network, allowing them to shift between zones depending on their requirements at the time, while still remaining in easy non-verbal contact. Studies of pilot implementations of this system have shown that they tend to reduce time wasted by waiting for responses or meeting attendees, while also increasing employee engagement, knowledge of each other's work, and ability to

work together ([Craig 2010](#)). This kind of workplace spatial / collaborative design can provide multiple benefits without pressuring individual workers.

5 Conclusion

The results presented here indicate that collaborative work by even a small group of people in a large space can rapidly increase noise levels. Larger groups talking would certainly exceed the levels seen here. Additionally, subject responses indicate that while collaboration can be achieved in a quiet or non-verbal manner, these restrictions had the result of hampering non-essential but potentially important communication. As such, it is important that the design of open-plan offices include support for impromptu collaboration, but also prevents it from becoming a hindrance to collaborators or those workers needing quiet. Advances in technological collaboration tools, such as instant messaging and others, may help accomplish this balance. In this way organizations can achieve the benefits of both collaborative and individual work.

6 References

Acoustical Society of America (2010). *ANSI/ASA S12.60-2010/Part 1 Acoustical Performance Criteria, Design Requirements, and Guidelines for Schools, Part 1: Permanent Schools*. Melville, NY.

ASHRAE (2010). Performance measurement protocols for commercial buildings. American Society of Heating Refrigeration and Air Conditioning Engineers. Atlanta.

Baldry, C. and A. Barnes (2012). "The open-plan academy: space, control and the undermining of professional identity." *Work Employment Society* **26**(228).

Buchanan, L. (1998). The Impact of Big 5 Personality Characteristics on Group Cohesion and Creative Task Performance. Doctor of Philosophy, Virginia Polytechnic University.

Craig, D. (2010). The workplace's impact on time use and time loss. DEGW.

Davis, T. R. V. (1984). "The Influence of the Physical Environment in Offices." *The Academy of Management Review* **9**(2): 271-283.

Dodds, T., B. Mohler and H. Bülthoff (2011). "Talk to the Virtual Hands: Self-Animated Avatars Improve Communication in Head-Mounted Display Virtual Environments." *PLoS ONE* **6**(10).

Evans, G. and J. Johnson (2000). "Stress and Open Office Noise." *Journal of Applied Psychology* **85**: 779-783.

eXo. (2014). "eXo Platform." from <http://www.exoplatform.com/>.

Fahlman, S. (1982, 13.9.2002). "Original Bboard Thread in which :-) was proposed." Retrieved 22.01.14, 2014, from <http://www.cs.cmu.edu/~sef/Orig-Smiley.htm>.

GSA (2006). *Innovative Workplaces: Benefits & Best Practices*. G. S. Administration.

Guye-Vuillème, A., T. Capin, I. Pandzic, N. Thalmann and D. Thalmann. (2014). "Nonverbal Communication Interface for Collaborative Virtual Environments." from <http://citeseerx.ist.psu.edu/viewdoc/download?doi=10.1.1.39.5083&rep=rep1&type=pdf>.

Hedge, A. (1982). "The Open-Plan Office: A Systematic Investigation of Employee Reactions to Their Work Environment." *Environment and Behavior* **14**(5): 519-542.

IBM. (2014). "IBM Connections." from <http://www-03.ibm.com/software/products/en/conn/>.

IFMA (2010). *Space and Project Mangement Benchmarks*. International Facilities Management Association (IFMA).

Inalhan, G. (2003). "Disproving Widespread Myths about Workplace Design." *Facilities* **21**(1/2).

Jensen, K., E. Arens and L. Zagreus (2005). "Acoustical Quality in Office Workstations, as Assessed by Occupant Surveys." *Indoor Air*: 2401-2405.

Lee, S. Y. and J. L. Brand (2005). "Effects of control over office workspace on perceptions of the work environment and work outcomes." *Journal of Environmental Psychology* **25**(3): 323-333.

Maher, A. and C. v. Hippel (2005). "Individual Differences in Employee Reactions to Open-Plan Offices." *Journal of Environmental Psychology* **25**(5): 219-229.

Microsoft. (2014). "Microsoft Sharepoint." from <http://office.microsoft.com/en-us/sharepoint/>.

Perham, N., H. Hodgetts and S. Banbury (2013). "Mental arithmetic and non-speech office noise: an exploration of interference-by-content." *Noise Health* **15**(62): 73-78.

Pinder, J., J. Parkin, S. Austin, F. Duggan, M. Lansdale, P. Demian, T. Baguley and S. Allenby (2009). *The Case for New Academic Workspaces*. L. U. Department of Civil and Building Engineering. Leicestershire, Department of Civil and Building Engineering.

Rasila, H. and P. Rothe (2012). "A problem is a problem is a benefit? Generation Y perceptions of open-plan offices." *Property Management* **30**(4): 362-375.

Sundstrom, E., R. Burt and D. Kamp (1980). "Privacy at Work: Architectural Correlates of Job Satisfaction and Job Performance." *The Academy of Management Journal* **23**(1): 101-117.

Sundstrom, E., J. Town, R. Rice, D. Osborn and M. Brill (1994). "Office noise, satisfaction, and performance." Environmental Behaviour **26**(2): 195-222.

Solar reflected glare affecting visual performance

Dr Luisa Brotas¹ and Dr Jan Wienold²

1 Low Energy Architecture Research Unit, Sir John Cass Faculty of Art, Architecture
and Design, London Metropolitan University, UK, l.brotas@londonmet.ac.uk

2 Interdisciplinary Laboratory of Performance-Integrated Design, EPFL ENAC IA
LIPID, Switzerland, jan.wienold@epfl.ch

Abstract

Visual comfort is important to the wellbeing of people and their productivity. However, too much light in the field of view can cause discomfort and disability glare. Under certain conditions it can even cause accidents. This paper addresses the disability glare created by veiling glare and the effect it may have of reducing the visual performance in outdoor spaces. Veiling glare is a particular case when light is reflected off a surface and causes annoyance or impairment of a task to the person in a particular view angle. Two factors that determine the nature and magnitude of veiling reflections are the specularity of the surface being viewed and the geometrical relationship between the observer, the surface and any source of high luminance. Different methods to assess disability glare exist but there is still no clear understanding on criteria to judge an outdoor scenario. A case study where reflected glare from Photovoltaics overlooking a building is of particular concern is presented.

Keywords: glare, reflected sunlight, visual comfort, Photovoltaic

1 Introduction

Visual comfort is important to the wellbeing of people and their productivity. Daylight is often acknowledged as contributing positively towards visual comfort. However, under certain conditions can be a negative effect and create discomfort or disability glare. Glare may occur when there is too much light, when the luminance range is too high and is within a given view angle of the observer. The wrong combination of these may have an impact on the ability of a person to perform a visual task.

Disability glare created by veiling glare may reduce the visual performance in outdoor spaces. This may be particularly relevant for air and road traffic where impairment of the visual task can even be the cause of accidents.

2 Glare assessment

Glare may occur when there is too much light, when the luminance range is too high and is within a given view angle of the observer. The wrong combination of these may have an impact on the ability of a person to perform a visual task. Glare can be quantified according to five classes:

- Saturation,
- Adaptation,
- Disability,
- Discomfort,
- Overhead glare.

Veiling glare is a particular case when light is reflected off a surface and causes annoyance or impairment of a task to the person in a particular view angle. Two factors that determine the nature and magnitude of veiling reflections are the specularly of the surface being viewed and the geometrical relationship between the observer, the surface and any source of high luminance. (SLL 2009)

This paper will only address the disability glare created by veiling glare and the effect it may have of reducing the visual performance.

Disability glare is an effect caused by the scattering of light in the eye which reduces the luminance contrast of the retina image. The disability glare formula was originally developed by Stiles and Holladay, and later with Crawford. Their work was further developed by Vos who highlighted the importance of the eye pigmentation and the age of the observer. In 2002, CIE published 3 disability formulae in the form of report 146. (Vos 2003a, 2003b; CIE 1999, 2002) These are based on the Stiles-Holladay glare equation and take into account the age of the observer, the ocular pigmentation and extend the angular domain over which the equations are valid. They all describe the Veiling Luminance due to a point glare source at an angle to the line of site that gives rise to an Illuminance in the plane of the observer's eye. All include age as a factor. The CIE General Disability Glare equation has a glare angle validity in degrees between 0.1° and 100° and also includes an eye pigmentation factor which plays a role at glare angles greater than 30° . A simplified definition in the CIE Age adjusted Stiles-Holladay Disability Glare equation with a restricted validity domain of 1° and 30° . The CIE Small Angle Disability Glare equation is a simplification applicable to the domain of the narrow angles between 0.1° to 30° . In different fields of application different degrees of accuracy are required. (CIE 2002a)

Vos addresses the Luminance distance to account for the Detection distance of an obstacle/focal point under conditions of glare. This is also affected by the age of the observer. (CIE 1999)

In disability glare for practical lighting considerations and only considering the physical phenomena of light scatter, the effects from multiple light sources are additive and extended light sources may be integrated. (CIE 2002b)

3 Calculation methods

In outdoor tasks or overlooking windows with reflected solar dazzle ahead it is of major importance to assess the magnitude of disability glare as the impairment of vision can cause accidents.

There are three dimensions to glare: temporal, spatial and intensity. For these it is important to predict the times of day and year when solar dazzle can occur. Because of its high intensity, one may assume that if solar reflection is within the field of view it will cause glare. Therefore it may be sufficient to estimate the period and position when it may occur.

Previous research highlights that it is not important to quantify the intensity of the reflected source on the assumption that any reflected glare will cause nuisance. However the degree to which it is an annoyance or impairment is strongly related to the view field. It also becomes relevant how to mitigate its effect. Correction measures will depend on a case to case basis. Littlefair (1987a and 1987b) provides the formulae to assess and quantify solar dazzle reflected from glazed facades. A graphical method (stereographic projection) to predict the periods and times of the year when solar dazzle may occur is also presented. Computer simulation programs are also available. (Wienold, 2006).

In particular situations when the focal point is surrounded by very bright sources (ie traffic lights seen against a bright facade) it may be important to assess disability glare with a CIE equation.

Schiler (2009) and SSK (2006) refer to absolute glare and relative glare. The former occurs when there is a (source of) luminance in the field of view which is sufficient to cause damage to the eye, no matter what the relative background level. Relative glare occurs when the eye can adapt to the background luminance level in a field of view but the contrast between a specific luminance in the field and the background exceeds some ratio. Relative glare was originally defined for interior conditions. Absolute glare was not a strong priority unless a very luminous light source was in place. That could be from an artificial light source or from reflected sunlight in a facing surface view through a window. Outdoors we may face much higher luminance sources, ie the sun or reflected sunlight. There is no point in addressing contrast ratios and absolute glare could be more relevant. However as previously highlighted solar dazzle will inevitably be glaring so is the position of the glare source and the temporal period of its occurrence that is important to assess.

Common computer simplifications in terms of geometries and definition of surface coatings have a major impact in the effective reflectance of light in facades in daylight studies. Mirror material commonly replacing glazing surfaces are assumed to aggravate the scenario as they maximise the specular reflectance compared to glass where the reflected component will vary for different angles of incidence, and where part of the flux will be transmitted indoors. Not all views of a glazed facade are glaring. Clearly the reflectance is strongly dependent on the coating characteristics of the glazing systems. Whereas this may be considered acceptable to highlight areas of potential glare, glass coatings and PV finishes may scatter more light and therefore aggravate the effect of reflecting light. To quantify the intensity and shape of the reflection it is necessary to characterize and model the bi-directional reflection properties of the surface. See Figure 1.

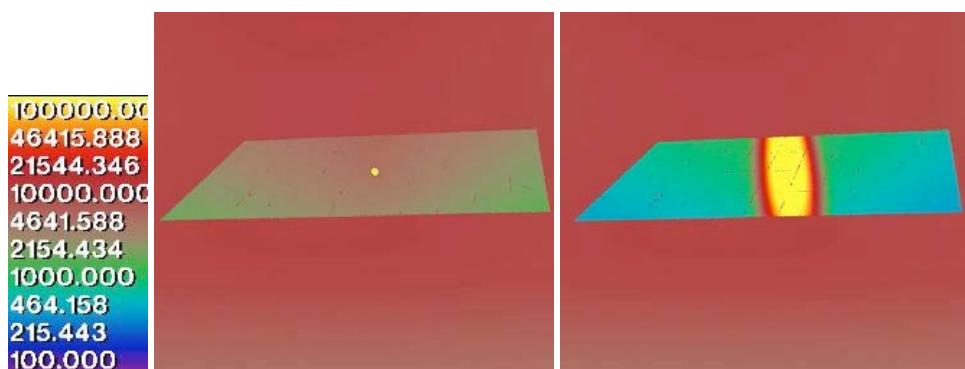

Figure 1. Falsecolor representation of the simulation of a normal glazing reflection where the sun is reflected as a point in the left image, and forward scattering properties where the sun is reflected as a band (source Wienold 2013)

Wienold (2013) presents a newly developed calculation method suitable for simulating the glare potential from PV installations, and to evaluate the effects of different reflection properties of glazing and their anti-reflective coatings. The method calculates the luminance of the reflection and the duration of glare conditions throughout the year. RADIANCE is the lighting software engine behind the calculation.

While indoors scenarios and discomfort glare have been object of several glare indexes, including the recent Daylight Glare Probability (Wienold, 2006) it is recognised that glare from daylight sources is relatively poorly understood (Osterhaus, 2005). This is vaguer when quantifying disability in outdoors. Previous literature found that an absolute luminance value above a certain threshold can be applied. This has been adopted in RADIANCE engine

as to calculate areas of glare. Ward two step method does not calculate glare per se but defines possible sources of glare. In the first instance the average luminance (similar to the background luminance) is calculated, the second step looks for luminance within the field of view that are greater than 7 times that value. (Ward 1991)

Conversely CIE Disability equations are being tested within Evalglare software by the authors and so is the mapping of the glare source in the visual field. When sources of glare are superimposed in an overall visual field mask, highlighted areas of disability glare are also related to areas of high impact in the restricted field of view: less than 3°, between 3° and 30°, in the influence of 60° and 100° within the view direction.

For outdoor spaces and for traffic situations it is not the time or duration of the occurrence of glare that should be investigated as glare should be prevented. It then becomes important the size and location of the glare source in regards to the view point as well a maximum allowed luminance below the absolute glare thresholds. Mitigating measures need to be investigated.

The situation of dazzle glare from a PV panel or a sunlight reflection of a glazing facade it is also important to also address the temporal basis: its duration and time of occurrence. An analogy can be made to studies on thermal comfort in particular the recent publication by CIBSE (2013) on how to prevent overheating in buildings in Europe. Three criteria are presented and a space is classed as overheating if fails any two out of three criteria:

“(1) The first criterion sets a limit for the number of hours that the operative temperature can exceed the threshold comfort temperature (upper limit of the range of comfort temperature) by 1 K or more during the occupied hours of a typical non-heating season (1 May to 30 September).

(2) The second criterion deals with the severity of overheating within any one day, which can be as important as its frequency, the level of which is a function of both temperature rise and its duration. This criterion sets a daily limit for acceptability.

(3) The third criterion sets an absolute maximum daily temperature for a room, beyond which the level of overheating is unacceptable.” (CIBSE, 2013)

For daylight analysis the problem is further aggravated as the eye has an ability to adapt to a wide range of luminance. An absolute threshold and an ‘hours over’ criterion may be a starting criteria. The relative luminance approach defining where high luminance sources are in regards to the average surrounding visual environment may be also applicable for indoor assessments. Then the field of view with a glare angle validity in degrees between a range defined in CIE disability glare formulae addresses its influence at the eye illuminance level. These are already or currently under evaluation with Evalglare software.

4 Results

Table 1 presents the results of glare calculation quantifying the duration of glare on different balconies. Days with half an hour or an hour are estimated. This goes in line with the first criterion adopted for assessing overheating in thermal comfort studies. What is still difficult to define is the quantification of this criterion. How much is too much? Different tasks and different places will require different thresholds and will certainly produce different satisfaction levels and productivity results. When does a sun patch in a dwelling change from a delight to an annoyance or impairment?

Table 1. Exemplary results of the glare calculations quantifying the duration and of glare on a balcony

		year	Jan	Feb	Mar	Apr	May	Jun	Jul	Aug	Sep	Oct	Nov	Dec
Balcony 1 st	sum h glare	77.9	8.6	15.9	13.1	0	0	0	0	0	5	19.3	11	5
	Days > 30min Glare	72	9	12	12	0	0	0	0	0	5	17	13	4
	Days> 1 h Glare	22	1	7	5	0	0	0	0	0	0	6	3	0
Balcony 2 nd	Sum h Glare	75.7	2.8	16	20.3	0.9	0	0	0	0	12	18.6	5.2	0
	Days > 30min Glare	55	2	12	17	1	0	0	0	0	8	11	4	0
	Days> 1 h Glare	34	0	8	10	0	0	0	0	0	5	9	2	0
Room 1st	Sum h Glare	41.4	9.3	6.2	0	0	0	0	0	0	0	6.3	11.3	8.3
	Days > 30min Glare	41	8	5	0	0	0	0	0	0	0	5	14	9
	Days> 1 h Glare	1	1	0	0	0	0	0	0	0	0	0	0	0
Room 2nd	Sum h Glare	38.6	6.2	9.6	2.6	0	0	0	0	0	0	9.8	7.3	3.1
	Days > 30min Glare	28	5	9	1	0	0	0	0	0	0	6	7	0
	Days> 1 h Glare	7	0	0	0	0	0	0	0	0	0	7	0	0

In an indoor condition the view outside to a highly reflected surface can be estimated as disability glare. Figure 2 provides an example of an absolute luminance when assessing disability glare from sources with high luminance values. The size and position of the glare source is of importance, much more than its intensity, assumed to exceed absolute thresholds. The occupant opportunity to adaptation namely operating blinds may be of extreme importance to minimize glare and its effect on the performance of the task.

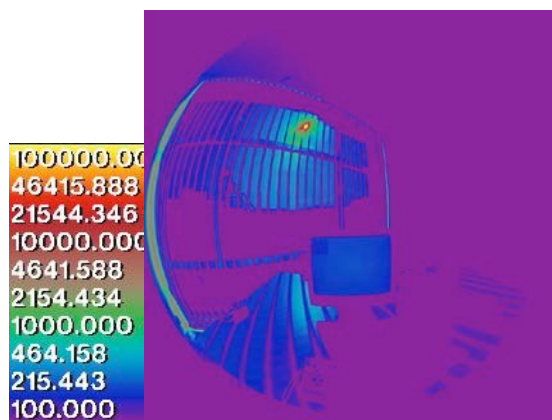

Figure 2. False color HDR image of the user assessments using the vertical foil shading. The luminance of the sun is comparable to the reflected luminance by a PV panel from the same direction (source Wienold 2013).

5 Discussion and Conclusion

Different methods exist to assess glare in indoor environments. These tend to assess discomfort glare. Disability glare poses a more difficult task as by its impairing nature can cause accidents. Calculation methods presented are able to estimate the glare effects caused by external surfaces like PV panels or dazzle glare from facades. However, there is still no consensual agreement on which method to adopt and even less on the criteria associated. There are clearly situations where disability glare cannot occur. Likewise the temporal degree and its subjective judgement call for further studies. Recently advances in thermal comfort have put forward a set of criteria that could serve as the basis to the development of a similar approach to glare. Depending on the type of glare under assessment, ie discomfort or disability different criteria may need to be satisfied. Similarly

to the adaptive comfort method, based on real data in buildings, glare should be based on field studies. There are still missing reliable studies on glare quantification in outdoor cases, when the sun is reflected to validate different criteria and substantiate a solid evaluation method. Nevertheless simulation methods are important to predict and prevent errors like recently examples in Los Angeles and London where reflected sunlight from facades are causing damage and impairment to neighbour spaces and its occupants.

References

- BSI (2007) *BS EN 15251:2007 Indoor environmental input parameters for design and assessment of energy performance of buildings addressing indoor air quality, thermal environment, lighting and acoustics*. London: British Standards Institution
- CIBSE (2013) *TM52:2013. The limits of thermal comfort: avoiding overheating in European buildings*. London. The Chartered Institution of Building Services Engineers
- CIE (1999) *CIE Collection 1999: Vision and Colour: Physical Measurement of Light and Radiation*, 135/1 Research note: Disability Glare, Commission Internationale de L'Éclairage, pp.1-10
- CIE (2002) *CIE Collection on Glare 2002: Equations for disability glare*, 146 CIE TC 1-50 report and *Glare from small, large and complex sources*, 147 CIE TC 3-01 report Commission Internationale de L'Éclairage
- Littlefair, P., (1987a) Prediction of Reflected Solar Dazzle from Sloping Facades, *Building and Environment*, 22(4), pp.285-291
- Littlefair, P., (1987b) Solar dazzle reflected from sloping glazed facades, IP 3/87, Building Research Establishment, Garston
- Osterhaus, W. K. E., (2005) Discomfort glare assessment and prevention for daylight applications in office environments. *Solar Energy*, 79(2):140–158.
- SLL (2009) *The SLL Lighting Handbook*, London: The Society of Light and Lighting
- Schiler, M., (2009) Examples of Glare Remediation Techniques: Four buildings, in proceedings PLEA 2009
- SSK, (2006) *Blendung durch natürliche und neue künstliche Lichtquellen und ihre Gefahren, Empfehlung der Strahlenschutzkommission (SSK)*, Bonn
- Vos, JJ., (2003a) On the cause of disability glare and its dependence on glare angle, age and ocular pigmentation. *Clinical and Experimental Optometry* 86(6), pp.363-370
- Vos, JJ., (2003b) Reflections on glare. *Lighting Research and Technology* 35(2), pp.163-176
- Wienold, J. and Christoffersen, J., (2006) Evaluation methods and development of a new glare prediction model for daylight environments with the use of CCD cameras. *Energy and buildings*, 38970, pp. 743-757
- Wienold, J., (2013) Glare caused by reflections of solar panels, in proceedings, LuxEuropa 2013

Proceedings of 8th Windsor Conference: *Counting the Cost of Comfort in a changing world* Cumberland Lodge, Windsor, UK, 10-13 April 2014. London: Network for Comfort and Energy Use in Buildings, <http://nceub.org.uk>

Analysing the Resilience of Brasília's Superblocks in a Changing Climate

M S. Franco³, M R. Kessler¹ and M. Samangoei²

1 Oxford Brookes University, mrbkessler@brookes.ac.uk

2 Oxford Brookes University, 10043333@brookes.ac.uk

3 mafaldafranco@gmail.com

Abstract

In *Six Degrees: Our Future on a Hotter Planet*, Mark Lynas describes possible world scenarios as global temperatures rise. The central region of Brazil, where Brasília is located, will suffer major changes in its microclimate.

Brasília's built environment has already provided a comfortable indoor and outdoor condition through planned urban design and vegetation. However, the constant increase in population and built area is threatening the local sustainability.

From damage prevention to future survival strategies, this paper highlights the importance of climatic design and urban directives in the struggle against a warming planet and resource depletion. One of Brasília's first super blocks, designed by Niemeyer, will serve as a case study. The discussion will focus on Brasília's iconic first housing estates and the ways they may contribute to energy efficiency as well as to the creation of strategies enabling the local community to respond to the climatic challenge. Monitored data of the present situation were analysed. The findings have suggested passive and active bio-climatic design and technology as a way forward. It is suggested that, under the current environmental circumstances, buildings are required to perform, like cars or refrigerators, like true "machines à habiter"; and their urban surroundings need to accommodate an ever-changeable microclimate in order to support the buildings' performance.

Keywords: Six Degrees, built environment, energy efficiency, urban design, microclimate

1 Background

Mark Lynas published *Six Degrees: Our Future on a Hotter Planet* in 2007 (2008 in USA) (Lynas, 2008). It is a non-fictional book about global warming. In his work Lynas describes the consequences of rising temperature on our planet, degree by degree, after very comprehensive and thorough research in the subject. An extra two degrees, threatens over a million species with extinction, including "163 tree species currently found on the Brazilian Cerrado savannah..." (Lynas, 2007:95) - the central high plain of Brazil.

This central region was strategically chosen to be the new capital of Brazil by the President Juscelino Kubitschek de Oliveira in order to fulfill an old plan of integrating the almost unpopulated western side of the country to the cosmopolitan and more developed coastline. During Juscelino Kubitschek de Oliveira's mandate, from 1956 to 1961, Brasília was designed, the construction started and the new capital was established.

The depletion of the region's natural resources has been a source of concern for quite a long time. According to Schenkel (Schenkel and Matallo, 2003), in the nineties, an assessment for vegetation loss in the Federal District of Brazil prompted a study about desertification in Brazil and the Caribbean. This document was published by UNESCO first in 1998 and then in 2001.

The desertification of fragile eco-systems has been discussed globally and there are several international groups of studies developing expertise for an alternative, more sustainable development for these areas. The Brazilian Centre for Strategic Studies and Management (CGEE), in preparation for the world conference and parallel international debates, RIO + 20, published a special edition of the report *Strategic Partnerships* (Redwood, 2012). In this report the significance of the dry areas in the world is well described by Redwood in his paper *Climate, sustainability and development in dry areas*. "Dry areas represent 40 % of the world's land and houses 30% of its population, from which 35% is poor and 16% lives in extreme poverty (around 50% of the world's poor). The dry areas are the most affected areas by climate change (Redwood, 2012, p.168). However those areas are also full of opportunities, responsible for a great part of the world's food production, rich in minerals, bio-diversity and a possible source for alternative energy – especially solar energy"(Redwood, 2012, p.177). In his conclusions, between threats and opportunities, Redwood highlights the importance of more planning and governance if those areas are to be protected.

Brasília was created with both a very precise plan and a very strong political will – a vision. However, Brasília was planned for a population of just 600,000 people and the "greater" Brasília has now around 3 million people (SDUMA, 2009). From the beginning of its construction, satellite cities have been mushrooming around the capital in order to accommodate the working class that built the capital but cannot afford to live in the heart of it. And since then, over the decades, a series of unlicensed settlements have been built, and later accepted within an underdeveloped political vision, hindered by profit motives and political gain.

Some of these "horizontal" settlements (Ribeiro e Póvoa, 2011) were not destined for the poor, but part of a lucrative continuum development without meaningful regulations. The fact that the region has very important aquifers was never an impediment.

One of the fastest growing administrative regions of the Federal District of Brazil, *Águas Claras* (Figure 1) (Clear Waters, hence the volume and quality of local water) is now served by a very modern metro service that connects the centre of Brasília to the satellite cities. Local construction has increased at an exponential rate, but, unfortunately, the budgets do not account for the protection of water resources, implementation of extra vegetation, and regulations on buildings distance in order to promote natural ventilation and appropriate climatic design for the area.



Figure 1. Águas Claras built environment and the metro line Source: (Brito Batista et al., 2013)

A new development in the Northwestern sector of Brasília, beside the National Park of Brasília, (an area that houses the reservoir responsible for 30% of the capital's water) was accepted despite enormous media and community outcry. This expensive residential area also sits on top of a significant indigenous site and an aquifer. The developers had to introduce systems to respond to the environmental impact of the new construction but the full picture is still unknown. The Paranoá Lake, an artificial lake designed in the creation of Brasília and part of the strategy to change the new capital's microclimate, should be monitored for sediments that will jeopardize its capacity. The large green areas designed and planted over the decades for surface water infiltration are not enough to face the unplanned growth the region has had. Bad consequences and flooding is starting to block the original road system.

2 Brasília's superblocks (superquadras) as planned

Lúcio Costa designed Brasília's master plan. Costa's design was inspired by Ebenezer Howard's Garden City (Howard, 1965); the key idea was to integrate green spaces within the built environment (marrying the town and country) and Clarence Stein's Neighbourhood Unit (Stein and Parsons, 1998); creating self-contained units to reduce travelling to amenities, each unit being large enough for a secondary school. The design of the city did not take into account an exponential growth in population. The Pilot Plan (masterplan) design for Brasília was developed by looking at the topography of the site and the natural flow of water. Two axes were formed which became the two main routes through the city (Figure 2).

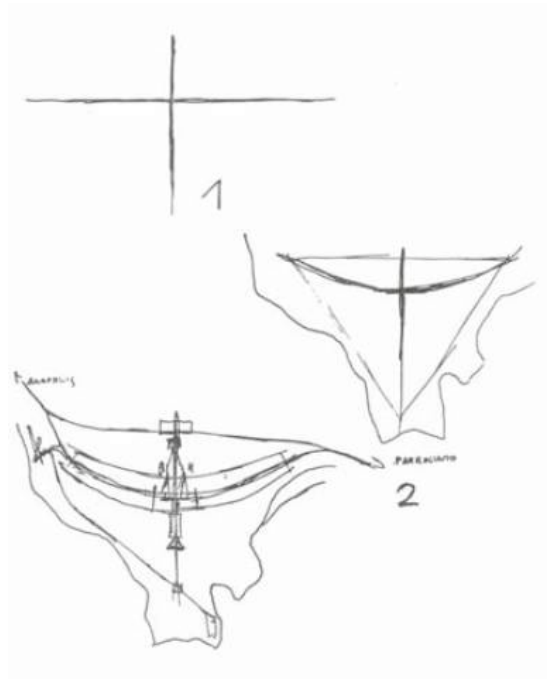

Figure 2. Lúcio Costa's sketch proposal for Brasília's Pilot Plan Source: (Staubli, 1966)

The two main routes are known today as the 'Eixo Monumental' (Monumental Axis) running East/West and the 'Eixo Rodoviário' (Road Axis) running North/South (Figure 3). Institutional, work and leisure sectors are located along the Eixo Monumental and the residential sectors, schools, cinemas and shops are located along the Eixo Rodoviário in the form of superblocs (Figure 3).

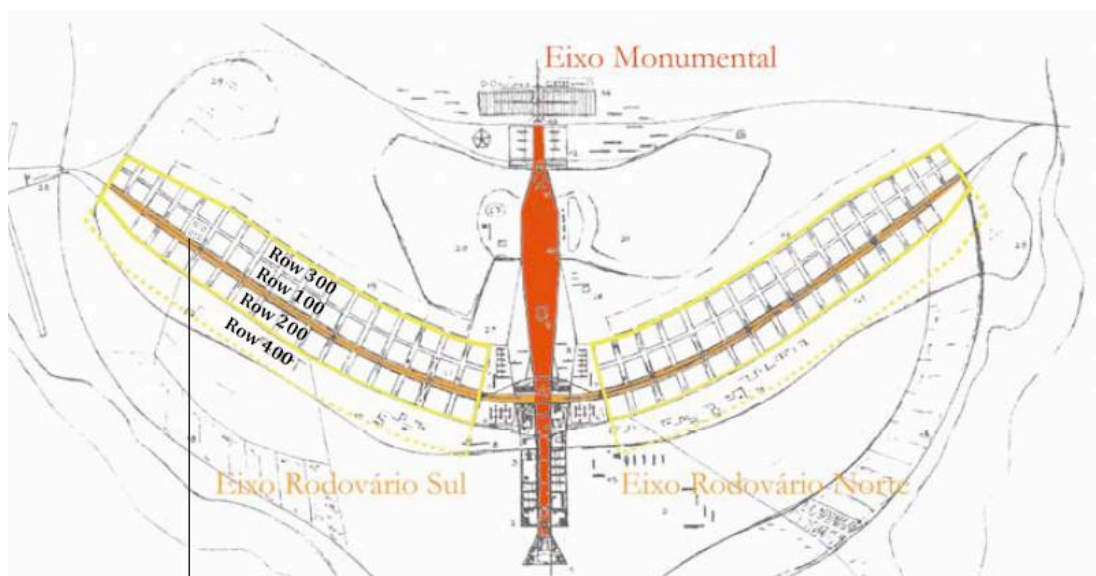

Figure 3. Location of the Axes, Superblocks and neighbouring units on the Pilot Plan

Source: (Authors own, M S. Franco)

The buildings in Brasília were built at two different periods; the first set in the 1960s-70s and the second set from 1980 until the present day. The first set of buildings

inside the superblocks were designed by Oscar Niemeyer in the 1960s. They were designed on stilts (pilotis) to allow free movement at ground level. Vegetation was planted at ground level, covering most of the superblocks. Each superblock was given its own character by planting different species in the grounds. As talked about above, the land that Brasília was built on did not naturally have much vegetation; Niemeyer's plan increased the existing planting (Figure 4 and Figure 5).



Figure 4. Superblock South (SQS) 108 under construction Source: (DesignKULTUR, 2013)



Figure 5. Superblock South (SQS) 108 today. Source: (Google maps)

The adaptation of the block designs are shown in Figure 6. Niemeyer designed the residential blocks as long and thin rectangles (12.5m by 85m) where the flats spanned the entire width of building (Plan A), allowing for good cross-ventilation. The 1960s Building Regulations did not allow any windows on the end elevations of the blocks. This then later changed by adding the service cores as blocks outside the rectangle (Plan B), due to the 1967 Building Regulations. Balconies were added in later designs (1975) (Plan C), which was confirmed by the 1989 Building Regulations requirement for balconies. These building regulations later resulted in Plan D, where smaller balconies were added (shaded in orange) and sections were taken out of the rectangular block (up to 1m) for services (shaded blue). These regulations later resulted in Plan E, where it was permitted for the cores to be inserted inside the rectangular block, which led to the flats no longer spanning the width of the block (1989). This led to the reduction of natural light and ventilation for the flats (Braga, 2005).

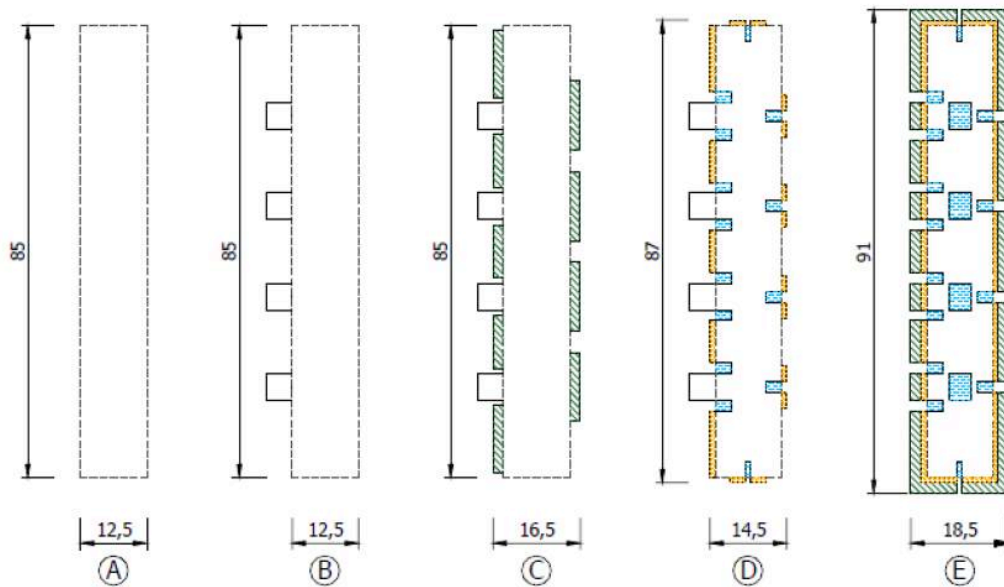

Figure 6. Successive changes in residential block plans over time (measurements in metres)

Source: (Braga, 2005, p.15)

3 Brasília's super blocks today

A study undertaken by Flores (2004) of 117 superblocks (1,392 residential blocks) of Brasília established that there are thermal comfort problems. The study found that people have added shading devices to the facades and air conditioning units.

Oxford Brookes University student, Mafalda Sofia Franco, funded by The Abbey Santander Scholarships 2009/2010, monitored (temperatures) one of the first and most iconic housing estates of Brasília. This paper sets M. S. Franco's results within a challenging future scenario in order to discuss resilience in the area.

Superquadras South (SQS) 108 and Superquadras North (SQN) 109 were monitored in September 2009 (mid-season) to investigate the comfort issues. One flat from each block was monitored using data loggers (ibuttons) over a period of two months and compared. The flat in 108 is on the 2nd Floor and the flat in 109 is on the 3rd Floor. Braga's (2005) study of the azimuth angle and solar radiation of the superblocks was used to select the superblocks that receive the most solar radiation, thus studying the blocks that are most vulnerable to overheating. SQS 108 is Plan B (from Figure 6, the flats span the width of the building) and SQN 109 is Plan E (from Figure 6, the flats do not span the width of the building). This section will discuss how the blocks were monitored and present some findings.

3.1 SQS 108

SQS 108, Block E (Figure 7) was chosen for monitoring as it represents the majority of the residential blocks in Brasília built in the 1960s-70s. SQS 108 was one of the original pilot superblocks designed by Niemeyer. The buildings in SQS 108 are surrounded by established vegetation and large trees (Figure 8).



Figure 7. SQS 108 Block E, North East elevation (the cobogó elevation) (top) and the South West elevation (the brise soleil elevation) (bottom) Source: (Author, M S. Franco)

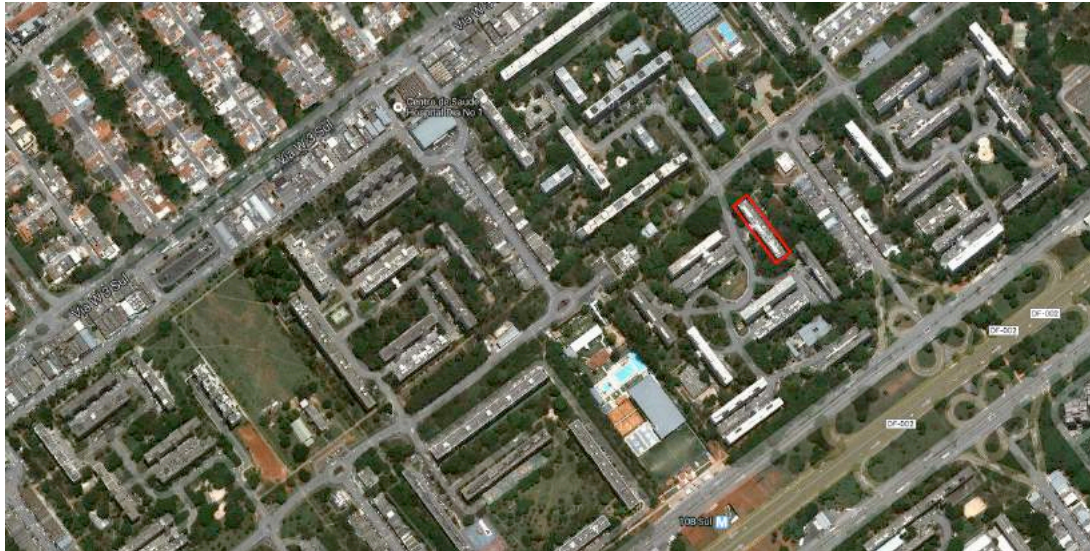

Figure 8. Aerial view of SQS 108 with Block E highlighted. Source: (Author and Google maps)

The flat monitored in Block E has no air conditioning units. The positions of the ibuttons are shown on the floorplan of the flat (Figure 9).

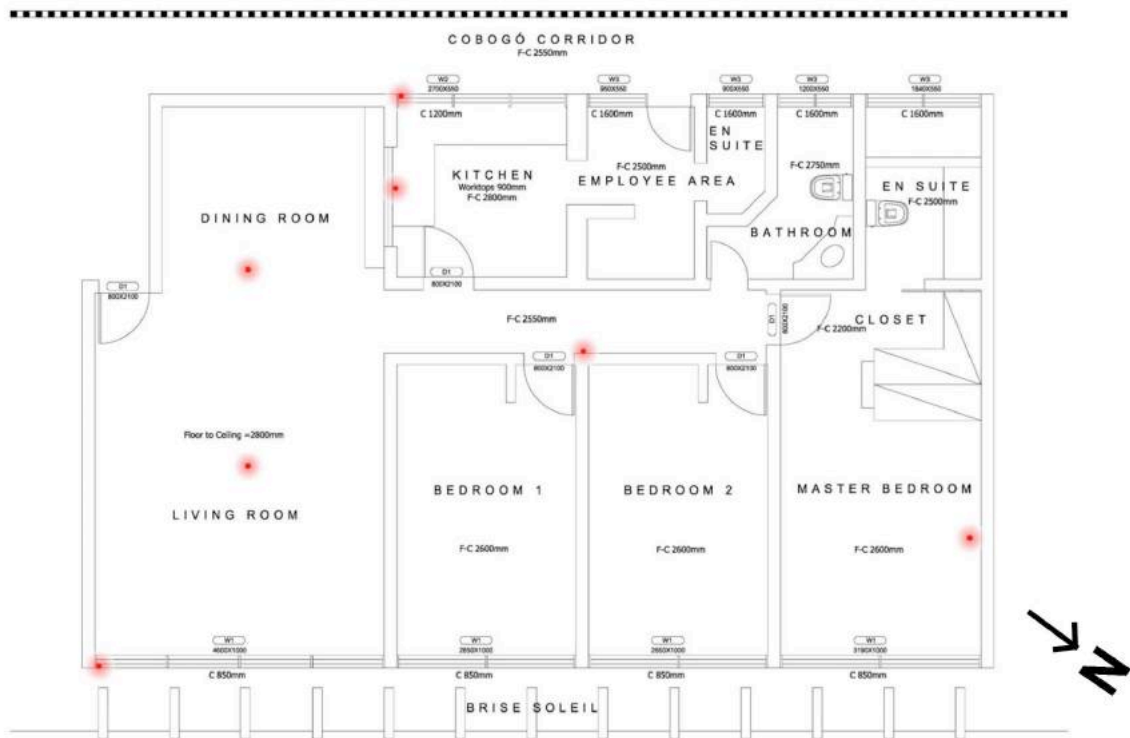

Figure 9. SQS 108, Block E Floorplan, 2nd Floor, highlighting where the ibuttons were placed
Source: (Author, M S.Franco)

3.2 SQN 109

SQN 109, Block N (Figure 10) was chosen for monitoring as it is a good example of the newer block designs (Plan E). The buildings in SQN 109 are not surrounded with much established vegetation and large trees at present and the floor plans have not been designed with cross-ventilation in mind (Figure 11).



Figure 10. SQN 109 Block N, North East elevation (top) and the South West elevation (bottom)
Source: (Author, M S. Franco)



Figure 11. Aerial view of SQN 109 with Block N highlighted, showing the lack of established vegetation Source: (Author and Google maps)

The flat monitored has air conditioning in every habitable room, however the unit was rarely switched on by the occupants during the monitoring period. The positions of the ibuttons are shown on the floorplan of the flat (Figure 12).

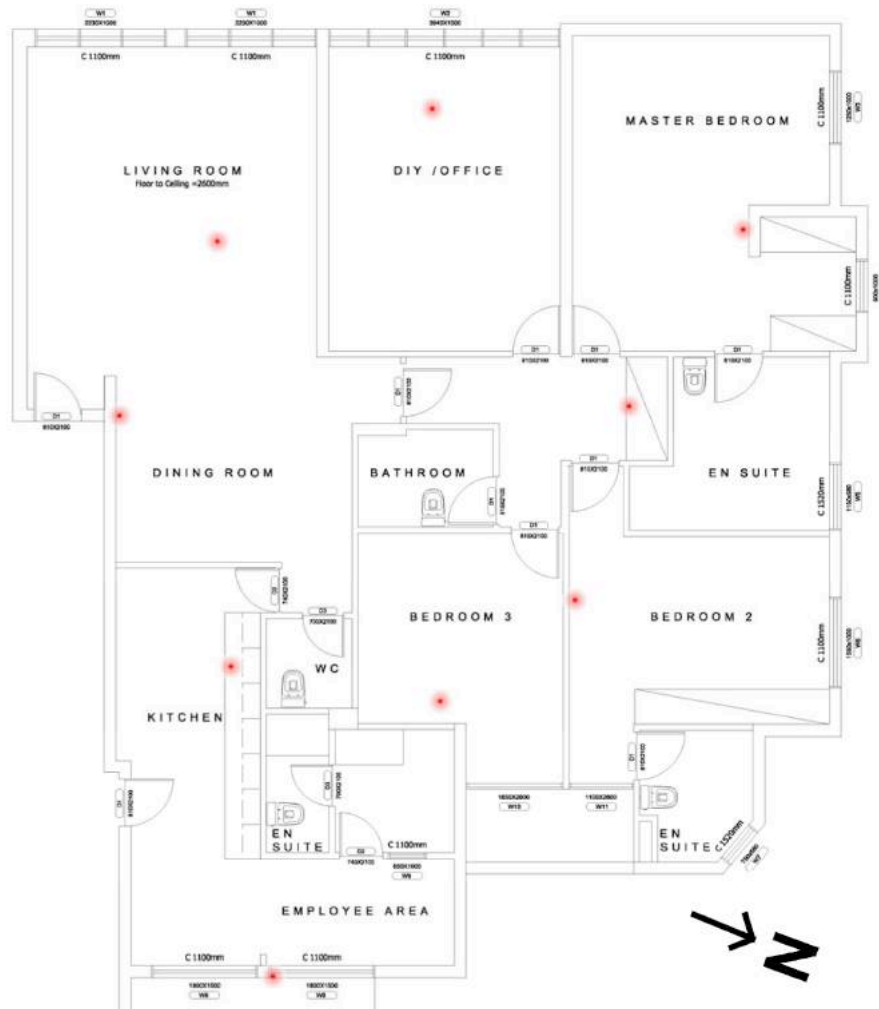

Figure 12. SQS 109 Block N, Floorplan, 3rd Floor, highlighting where the ibuttons were placed.
Source: (Author, M S.Franco)

3.3 Monitoring results and findings

Figures 13, 14 and 15 show the temperatures monitored in SQS 108 and SQN 109. SQS 108 was not experiencing temperatures higher than 26 degrees Celsius. However SQN 109 was experiencing temperatures up to 28 degrees Celsius. These findings show that the climatic design of the original blocks is currently successful; passive cooling with the use of cross-ventilation and a cooler microclimate provided by the surrounding vegetation, which are key areas that are lacking in SQN 109. Further monitoring of the flats on the top floor of SQS 108 is needed as these flats are less shaded by the surrounding trees compared with the flats lower down. This would give an indication as to how much the vegetation contributes to keeping these flats cool and how important cross-ventilation is in comparison.

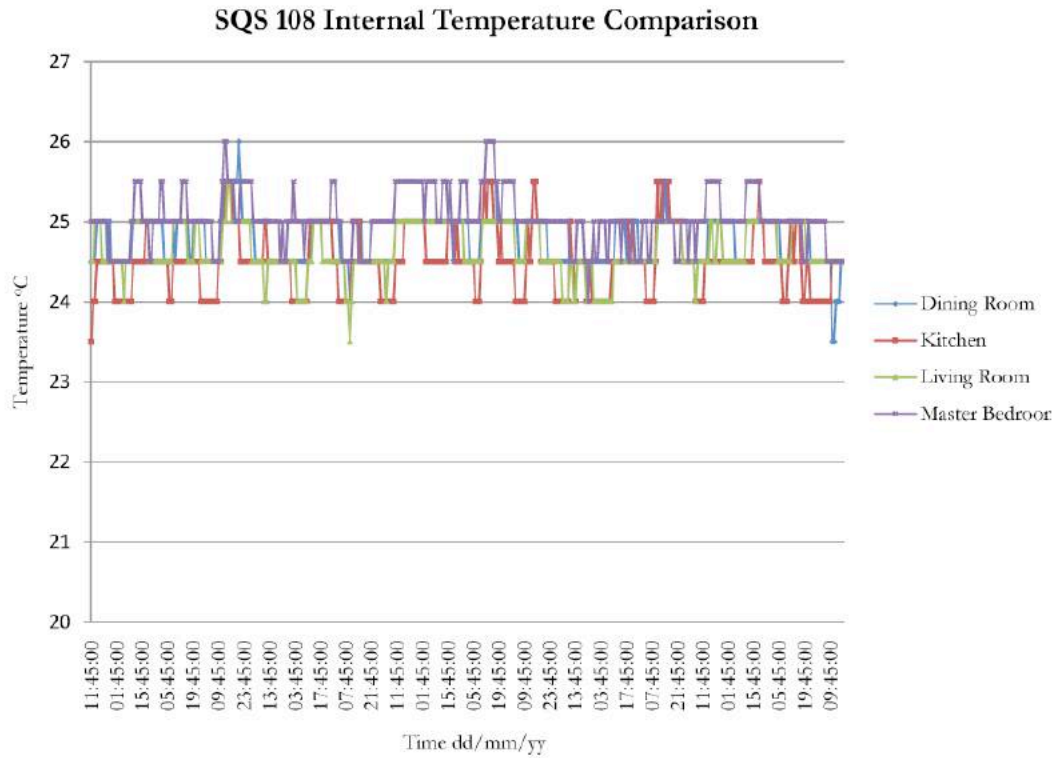

Figure 13. SQS 108, Recorded internal temperature Source: (Author, M S.Franco)

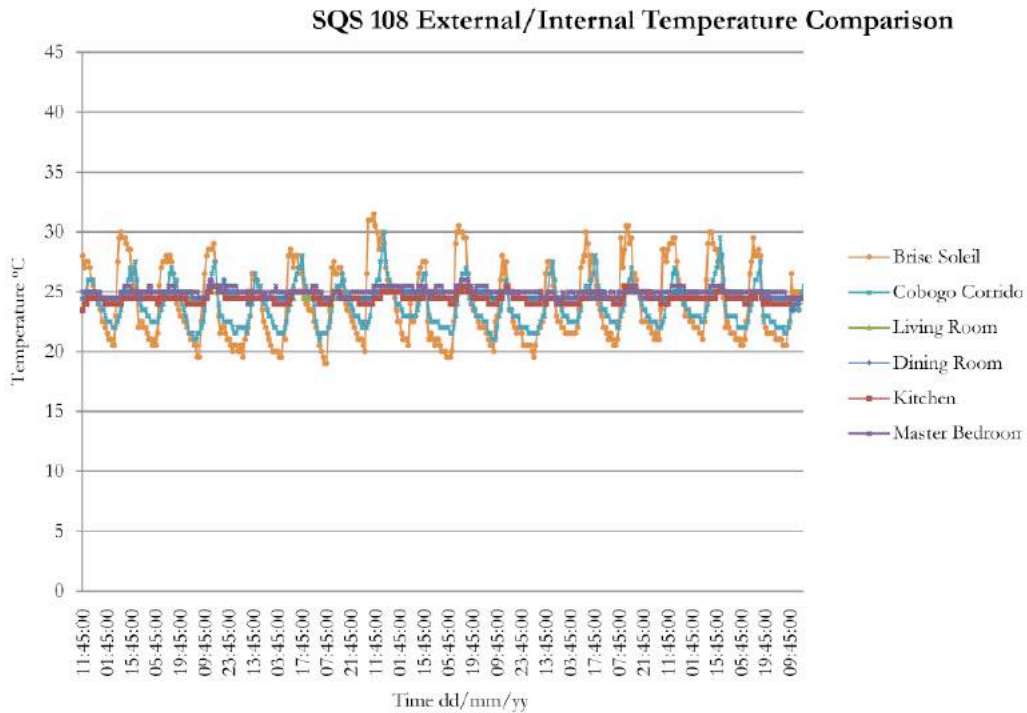

Figure 14. SQS 108, Recorded internal temperature with recorded external temperatures Source: (Author, M S.Franco)

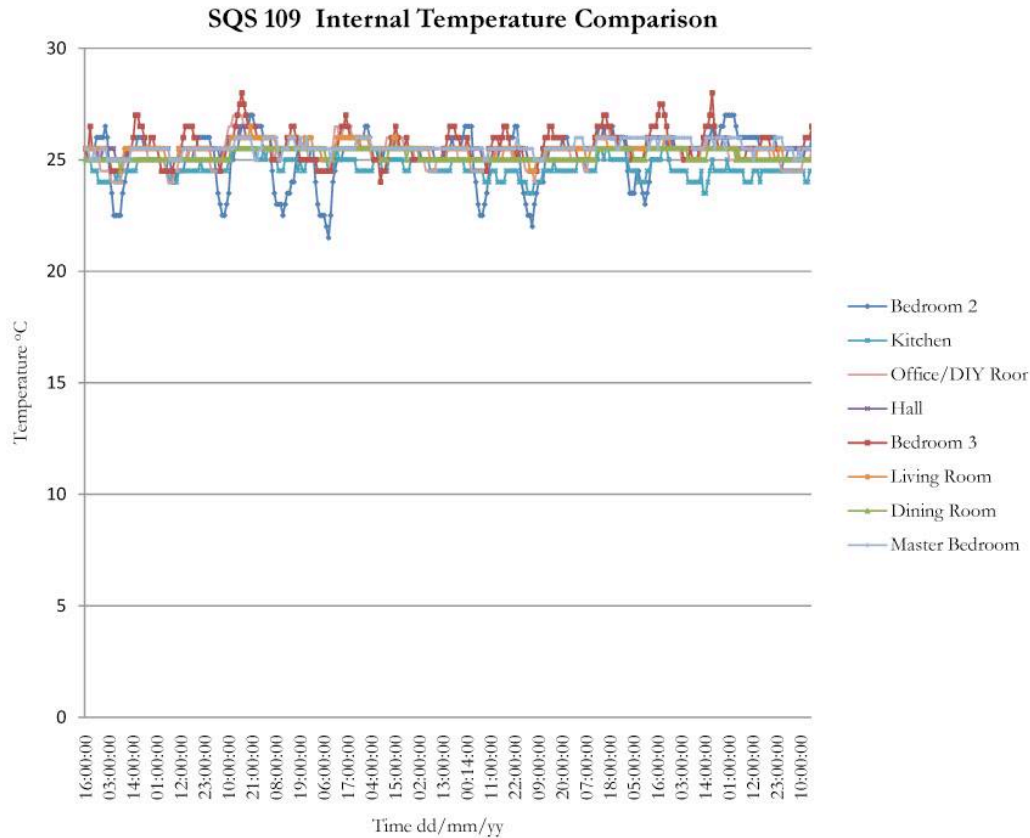

Figure 15. SQN 109, Recorded internal temperature Source: (Author, M S.Franco)

4 Related researches: the importance of urban microclimate and water conservation

L. M. B. Castelo Branco's masters dissertation for the University of Brasília, Urban Microclimates in Brasília's Pilot Plan – a case study of the SQS 108 (Castelo Branco, 2009) brings to light the importance of urban surroundings for the building's performance. Green areas as well as other ground covers and the urban morphology affect the air and ground temperature, the relative humidity and air movement.

The monitoring of outdoor conditions was carried out and the value of the airflow was measured. Findings reinforce the need to preserve the area's greenery and the quality of the ventilation if passive solutions are to be effective.

In the dry season, if trees protect the ground from the sunlight during the day, at night they can shield radiation. In this situation the low vegetation (grass or the introduction of vegetable gardens) presents better results. During this season evaporative cooling is very effective, hence reinforcing the need for irrigation.

During the rainy season the low vegetation also helps to maintain low temperatures. The lower temperatures under the trees were related to a higher level of ventilation. The humidity is related to the air temperature; and in the dry season, when temperatures are higher, evaporative cooling can be effective, however in the humid season arrangements must be made for air movement to increase (Figure 16). Raising the building off the ground, as in block 108, facilitates air movement.

The use and conservation of water in Brasília's housing estates is discussed in detail in Daniel Sant'Ana's work (Sant'Ana, 2012, Boeger and Sant'Ana, 2013). His graph relating the dry season to the increase in water consumption, as seen below, is revealing.

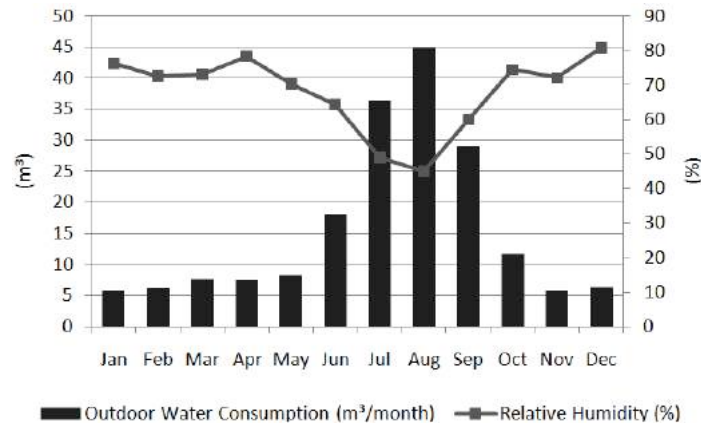

Figure 16. Relation between outdoor water consumption and relative humidity.

Source: (Sant'Ana, 2012)

According to Sant'Ana, new equipment and appliances for efficient water use, rainwater harvesting systems and even water reuse systems for outdoor non-potable use, are economically sound for today's budgets. Government policies and subsidies should promote these changes. However incorporating indoor non-potable water reuse systems is still unviable as it is expensive to change all the pipe work.

In the future, not just the new technologies but also the consequences of the inevitable high demand of the natural, regional systems of aquifers that have been so neglected over the years, could change drastically the results in the above calculations.

5 Conclusions

The research presented in this paper has highlighted the necessity of planning and political will. Regulations may be needed to guide designers and developers to create buildings like the original, naturally ventilated models from the 1960s, which were able to provide comfortable environments without auxiliary cooling. SQS 108, if the vegetation is to be preserved and water conservation undertaken, can be resilient to a warming climate. If temperatures rise, during the humid season, air movement may need to be increased. In the future, buildings will be required to have the most appropriated design and technology to perform as efficient machines, like true "machines à habiter".

References

BOEGER, L. & SANT'ANA, D. 2013. Análise de Viabilidade para o Aproveitamento de Água Pluvial em Edifícios Residenciais em Brasília. *Terra – Qualidade de Vida*,

Mobilidade e Segurança nas Cidades. Paraíba, Brazil: Universidade Federal da Paraíba.

BRAGA, D. K. 2005. Arquitetura residencial das superquadras do Plano Piloto de Brasília: aspectos de conforto térmico. Available: http://bdtd.bce.unb.br/teedesimplificado/tde_busca/arquivo.php?codArquivo=24 [Accessed 22nd February 2013].

BRITO BATISTA, G., NEVES JUNIOR, J. L. & PICOLI, R. L. 2013. Impactos ambientais na implantação de condomínios horizontais no distrito federal e o papel do gestor ambiental neste processo. *IV Congresso Brasileiro de Gestão Ambiental*. Salvador, Bahia: IBEAS – Instituto Brasileiro de Estudos Ambientais.

CASTELO BRANCO, L. M. B. 2009. Microclimas Urbanos no Plano Piloto de Brasília: o Caso da Superquadra 108 Sul. In: UNB, F. (ed.) *Dissertação de Mestrado Programa de Pós-Graduação*. Brasília.

DESIGNKULTUR. 2013. *Cities* [Online]. Available: <http://designkultur.wordpress.com/2012/09/17/cities-construcao-de-brasil-building-brasil/> [Accessed 22nd November 2013].

HOWARD, E. 1965. *Garden Cities of Tomorrow*, MIT Press.

LYNAS, M. 2008. *Six Degrees: Our Future on a Hotter Planet*, UK, Harper Perennial.

REDWOOD, J. 2012. Clima, sustentabilidade e desenvolvimento em terras secas. *Parcerias Estratégicas, Edição Especial RIO + 20*, 17, 167.

RIBEIRO E PÓVOA, E. 2011. Distrito Federal, Ações Estruturantes. Available: <http://www.brasilportugal.org.br/novo/imagens/file/DF%20AÇÕES%20ESTRUT%200visualização.pdf> [Accessed 22nd November 2013].

SANT'ANA, D. 2012. Domestic Water End-Uses and Water Conservation in Multi-Storey Buildings in the Federal District, Brazil. *Opportunities, Limits & Needs Towards an environmentally responsible architecture Lima*. Peru: PLEA.

SCHENKEL, C. S. & MATALLO, H. J. 2003. Desertificação. Available: www.unesco.org.br [Accessed 22nd November 2013].

SDUMA. 2009. Zoneamento Ecológico-Econômico do Distrito Federal. Available: <http://www.zee-df.com.br/Arquivos%20e%20mapas/Volume%20II%20-%20Socioeconomia.pdf> [Accessed 22nd November 2013].

STAUBLI, W. 1966. Brasília. New York: Universe Books.

STEIN, C. & PARSONS, K. C. 1998. *The writings of Clarence S. Stein*, Johns Hopkins University Press.

Proceedings of 8th Windsor Conference: *Counting the Cost of Comfort in a changing world* Cumberland Lodge, Windsor, UK, 10-13 April 2014. London: Network for Comfort and Energy Use in Buildings, <http://nceub.org.uk>

Visualizing the results of thermal comfort field studies: putting publicly accessible data in the hands of practitioners

Margaret Pigman, Hui Zhang, Anoop Honnekeri, Ed Arens, and Gail Brager

Center for the Built Environment, University of California, Berkeley

Abstract

Large sets of thermal comfort field data have been analysed in detail to inform generalized thermal comfort standards, but there is specific information that might be relevant to particular projects that is not easily accessed by practitioners. We developed interactive tools that allow users to explore the data and look at the subsets that are most interesting to them because of location, culture, building type, etc. The first tool displays curves of dissatisfaction percentages for ranges of thermal sensation, PMV, and indoor temperature based on the comfort metrics of acceptability, comfort, and sensation. Using this tool, we show that a thermal sensation range of -1.3 to 1 provides 80% satisfaction based on acceptability and comfort in both naturally ventilated and air conditioned buildings. The second tool provides a new way of analysing and representing data in these datasets that calculates satisfaction percentage directly, and visualizes the results clearly. We demonstrate how the interactivity allows users to answer project-specific questions. While our visualization method is helpful for displaying the data, it does not provide a mathematically defined comfort zone. We discuss future avenues of development of these tools.

Keywords: thermal comfort, data visualization

1 Introduction

The goal of ASHRAE Standard 55 is to define the conditions under which at least 80% of a building's occupants will be satisfied with the thermal environment. In the case of naturally ventilated (NV) buildings, these conditions are described by the adaptive model, which indicates comfortable indoor temperatures based on monthly mean or running mean outdoor temperature (ANSI/ASHRAE, 2013).

Although the final adaptive model is given in terms of indoor and outdoor temperature and percent satisfaction, the fundamental steps for deriving it also included thermal sensation. Using a large database of thermal comfort field studies, de Dear and Brager found the neutral temperature for each building during each season by calculating a linear regression between indoor temperature and thermal sensation. These neutral temperatures and their associated mean monthly outdoor temperatures were then plotted against each other, and the overall model was found by running a regression through these points. In order to determine the comfort zone, i.e. the deviations from the neutral temperature that still allow 80% satisfaction, they used the PMV-PPD relationship derived by Fanger from chamber studies (de Dear & Brager, 1998).

The European thermal comfort standard for naturally ventilated buildings also relates comfortable indoor temperatures to outdoor temperature, in this case defined as running mean (CEN, 2007). Although the details differ, McCartney and Nicol's analysis of the SCATs database was similar to de Dear and Brager's. They first

calculated neutral comfort temperature based on a relationship between indoor temperature and thermal sensation and then ran a regression between comfort and running mean temperatures to develop their adaptive curve (McCartney & Nicol, 2002). To determine the range of comfortable temperatures, they relied on Fanger's assumption that thermal sensations of -1, 0, and 1 indicate satisfaction and plotted the proportion of people who were satisfied with the thermal conditions as a function of the difference between the actual temperature and the neutral temperature. The deviations from the neutral temperature that were included in the standard are based on 15%, 25%, and 35% dissatisfaction, although the dissatisfaction percentages are not mentioned in the standard (Fanger, 1982; Nicol & Humphreys, 2010; CEN, 2007).

In both these cases, the desired relationship is between indoor and outdoor temperature, but it is mediated by thermal sensation in finding a neutral or comfort temperature. Outdoor temperature is only introduced as a secondary step.

The data from numerous thermal comfort field studies around the world is publicly available in the ASHRAE RP-884 database. The European-based SCATs database has not been publicly available to date, but we were given access to it, and there are plans to make it publicly available soon. Both of these databases have been analysed in detail to inform generalized thermal comfort standards, but there is specific information that might be relevant to a particular project that is not easily accessed by practitioners.

The goal of this project is to

- Determine the range of thermal sensation votes that indicate satisfaction.
- Develop a method of visualizing and identifying a comfort zone directly using thermal comfort or thermal acceptability metrics, when available, rather than by way of thermal sensation and neutral temperature.
- Create interactive tools to provide practitioners with easy and useful access to publicly available thermal comfort field data, so they can conduct their own analysis.

2 Methods

This project is based on thermal comfort field study data from the ASHRAE RP-884 and SCATs databases as well as two separate studies in the San Francisco Bay area (de Dear & Brager, 1998; McCartney & Nicol, 2002; Brager et al., 2004, Zhang et al., 2007; Linden et al., 2014). The aggregated database contains 32,055 observations from 169 buildings in 11 countries; 148 of the buildings are offices, and the others include houses, schools and factories. About half of the observations come from naturally ventilated (NV) buildings, which are the ones we focus on in this paper. The remaining half come predominantly from air conditioned (AC) buildings, but there are also some from mixed-mode (MM) buildings. All of the respondents were asked to rate their thermal sensation on the 7-point ASHRAE scale. In 70 buildings (38% of observations), respondents were asked about thermal acceptability, and in 97 (45%) they were asked about overall thermal comfort.

First we examine which votes represent “satisfied”, since most field studies don't ask directly about satisfaction with the thermal environment. Instead, researchers look to questions about thermal sensation, acceptability, preference, and comfort to assess satisfaction (Arens et al., 2010; Zhang et al., 2011). Thermal sensation is the most widely reported response, so it is a very useful metric to use. But it is not clear what

range of sensation should be considered satisfied. Fanger assumed that individual thermal sensation votes of -1, 0, and 1 indicated satisfaction and used probit analysis to derive the PMV-PPD relationship from that. Although de Dear and Brager did not explicitly define a satisfied range of thermal sensation for individual votes, they did so implicitly by calculating the 80% satisfaction limits based on an average thermal sensation of ± 0.85 . This value comes from the PMV-PPD curve and has not been justified with field data by directly comparing thermal sensation and comfort or acceptability votes (de Dear & Brager, 1998; Fanger, 1982). Nicol and Humphreys explicitly accepted this assumption in deriving the limits of the three classes of thermal comfort for EN 15251 (Nicol & Humphreys, 2010).

We utilize studies that asked questions about acceptability or comfort in addition to sensation in order to determine an appropriate range of thermal sensation. Following the methodology that Fanger used to develop the PMV-PPD curve, we use probit analysis to predict the percentage of dissatisfied votes (Fanger, 1982). However, we use individual thermal sensation votes instead of PMV. Probit models fit s-shaped curves to systems with a dependent variable that has two possible values. In this case, we fit separate probits to votes that are dissatisfied because of being too hot and too cold. The total dissatisfaction percentage is the sum of the hot and cold dissatisfied percentages. We divide the data into satisfied and dissatisfied based on acceptability or comfort and then use thermal sensation to determine whether the person was hot or cold. The tool calculates the appropriate probits for three different comfort metrics (sensation, comfort, acceptability) and three different independent variables (sensation, PMV, indoor temperature).

Adaptive comfort standards relate comfortable indoor temperatures to outdoor temperature. In order to visualize satisfaction in this framework, we bin thermal comfort votes according to the indoor and outdoor temperature conditions under which they were given. Then within each two-dimensional bin we calculate the percentage of satisfied votes. For acceptability, comfort, and the common assumption of ± 1 thermal sensation, the satisfaction percentage is calculated by counting the number of satisfied votes and dividing by the total number of votes in each bin. However, this method cannot be applied to the relationship derived using the probit analysis because individual thermal sensation votes are not sure to indicate satisfaction or dissatisfaction. In other words, someone recording a thermal sensation of +1 will be satisfied only 80% of the time and so cannot be counted as satisfied (Figure 3a). So instead of counting satisfied votes in each bin, we convert each thermal sensation vote to its probability of having a coincident “acceptable” vote and average those probabilities. An accumulation of bins with at least 80% satisfaction delineate the comfort zone.

3 Results

We developed two interactive visualization tools that give practitioners and researchers an easy way to select subsets of thermal comfort field study databases that are interesting to them (Figure 4). The tools are built with the statistical package R, using the “ggplot2” library for visualization and the “shiny” library as the interface between R and html (R Core Team, 2013; Wickham, 2009; RStudio Inc., 2013). The user interface has dropdown menus, sliders, and input fields that allow users to filter the overall database based on the building location, cooling strategy, and program. Users can choose the metrics for the axes and for calculating satisfaction, the width of the bins, and the minimum number of votes that are required in a bin for it to be

displayed. The screen then gives them immediate feedback, visualizing the results based on the input parameters and filters. In addition to the graph, there is a data table that indicates the sources of the data and the mean values of the basic physical and survey responses for each city that is included.

3.1 Percent dissatisfaction tool

This tool uses probit analysis to display the percentage of dissatisfied votes as a function of a variety of metrics - thermal sensation, PMV, or indoor temperature - and plots the corresponding probits. The four metrics for calculating satisfaction (or conversely, dissatisfaction) are acceptability, thermal sensation, comfort, and preference (Figure 1).

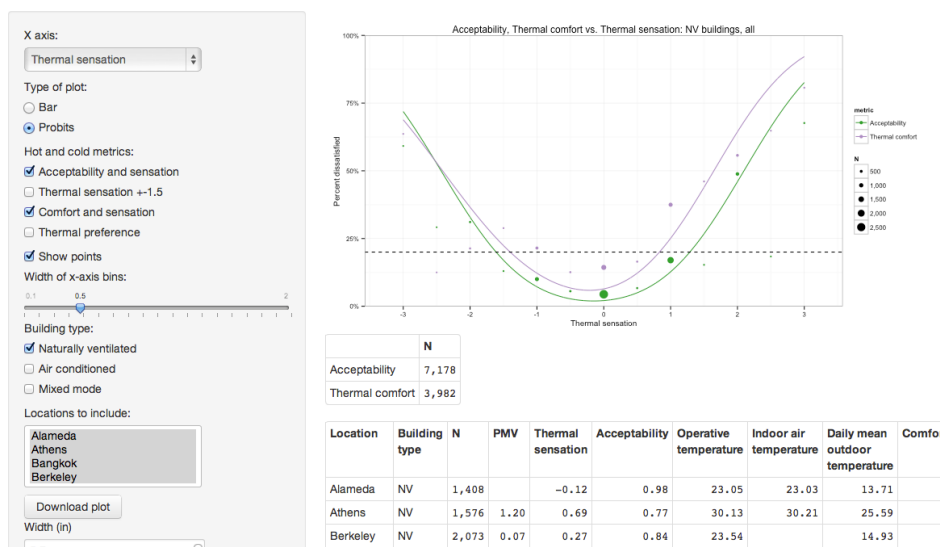

Figure 1. Screenshot of probit analysis tool

To determine a reasonable range of thermal sensation that can be considered satisfactory, we used this tool to analyze the results of those studies that asked acceptability and/or general comfort questions in addition to a sensation question. Figure 2a shows the probit curves for NV buildings using acceptability and comfort. We were surprised that they showed only about 65% dissatisfaction at a thermal sensation of -3, so we looked through the probits for individual cities to see if we could see why. We found that in Honolulu, only 10% of people rated -3 thermal sensation as being unacceptable and only 40% rated it as being uncomfortable (Figure 2b, dots). We concluded that these results might be because they are from school children, so we excluded Honolulu from further analysis. Figure 2c shows the result without the buildings in Honolulu. We describe these steps as an illustration of the benefits of this interactive tool, which makes all of these steps of the analysis quick and easy to do.

In all of these graphs, the comfort metric results in a slightly narrower range of thermal sensation that provides a given level of satisfaction than the acceptability metric does (Figure 2c). These results cannot be compared directly to Fanger's assumption that sensations of -1, 0, 1 are comfortable and that other sensations are not, since it indicates that there are no sensations that guarantee 100% comfort or discomfort.

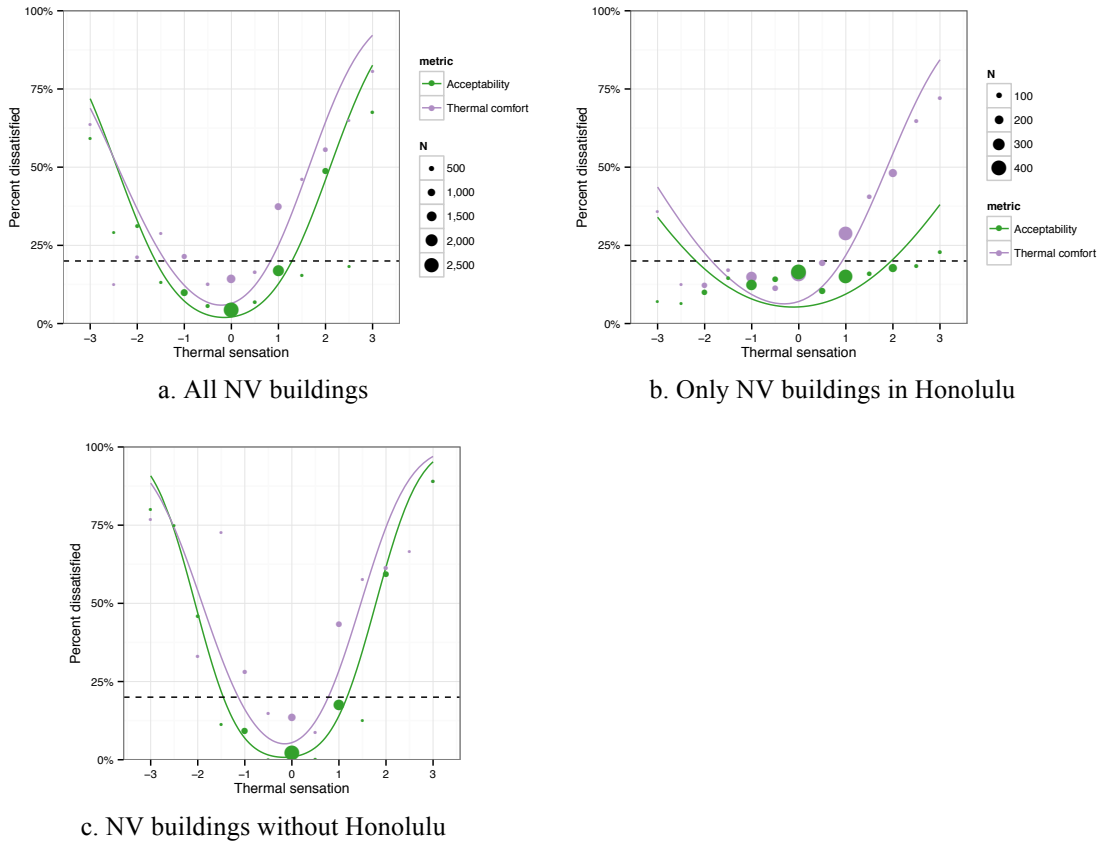

Figure 2. Dissatisfaction vs. thermal sensation for NV buildings

Figure 3a compares the probit curves of dissatisfaction based on acceptability vs. thermal sensation for NV and AC buildings. They are virtually identical, particularly for dissatisfaction less than 20%, but also across the whole range of thermal sensation. However this does not mean that the physical conditions that correspond to these sensations and levels of satisfaction are the same for both types of buildings. In fact, the range of operative temperatures that provide 80% satisfaction is about 18-28 °C for NV and only 20-25 °C for AC buildings. Beyond these ranges, the dissatisfaction percentage for NV buildings is up to 30 percentage points below that of AC buildings for the same temperature (Figure 3b).

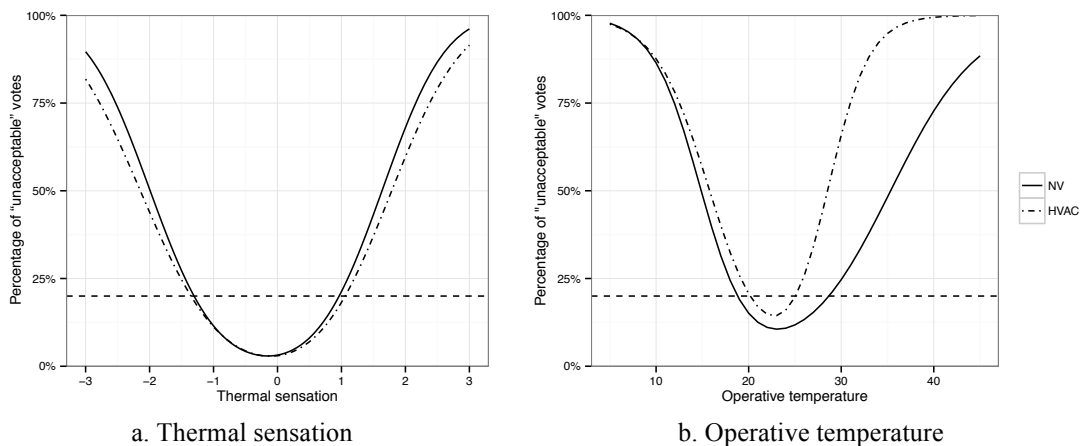

Figure 3. Dissatisfaction based on acceptability: comparison of NV and AC buildings excluding Honolulu

3.2 Satisfaction mapping tool

This tool visualizes comfortable indoor environmental conditions mapped against outdoor temperature. It follows the convention of ASHRAE 55 and EN 15251 and puts indoor temperature on the y-axis and outdoor temperature on the x-axis. Depending on the source of the data, outdoor temperature is either monthly mean or running mean and therefore is referred as “prevailing outdoor temperature”. Satisfaction (comfort) is represented by color, with percentages above 80% being green. The user can choose which metric is used to calculate satisfaction (Figure 4).



Figure 4. Screenshot of visualization tool

Figure 5 shows indoor-outdoor temperature bins that provide 80% satisfaction for NV buildings based on acceptability votes. From this visualization, the upward trend of green bins makes it clear that acceptable temperatures vary depending on the daily mean outdoor temperature. However, only about half of the observations in NV buildings are displayed in this particular graph, because many field studies did not ask a question about thermal acceptability. This limitation pointed to the need for another kind of analysis.

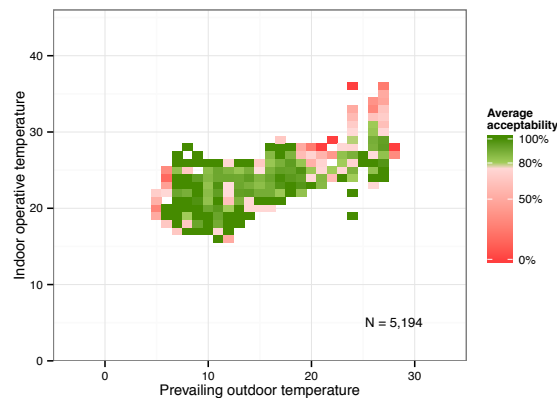

Figure 5. 80% satisfaction zones for NV buildings based on thermal acceptability

In order to use data from all of the studies, we use the relationship between thermal sensation and acceptability that we developed above (Figure 3a) to replot what we did in Figure 5. Because the green region is mostly bounded by red and pink, including all of the data defines the comfort zone a bit better (Figure 6a). From Figure 5 it is not

clear what the upper limit for indoor comfort temperature is for outdoor temperatures below 20 °C because the upper edge of the green region is not bounded by red. This problem is cleared up in **Figure 6a**, where the red region follows the upward slope of the green band.

The interactive tool allows users to explore the data in a variety of ways, depending on their interests or applications. Which results are we most confident about? Some of the bins have hundreds of observations and others only one, so we can use the filter to increase the minimum number of observations per bin (**Figure 6b**), and compare this to the results for all bins (**Figure 6a**). This shows that, in general, the bins at the upper and lower bounds of indoor temperature for each outdoor bin have fewer observations, so we are not as confident about their satisfaction rate as we are about other bins. Even so, the upper indoor temperature limit of 80% satisfaction (green squares) is reasonably well defined. One can also use the tool to ask - does it make a difference if the people are in NV or HVAC buildings? Selecting only the HVAC buildings shows that votes were cast in a narrower range of indoor temperatures and that indoor and outdoor temperatures are not strongly related. This is what we would expect in these buildings. A new contribution that this visualization method provides is that it shows that the width of the comfort zone is smaller and more well defined in HVAC than NV buildings because there are dissatisfied regions above and below the green band (**Figure 6 c&d**).

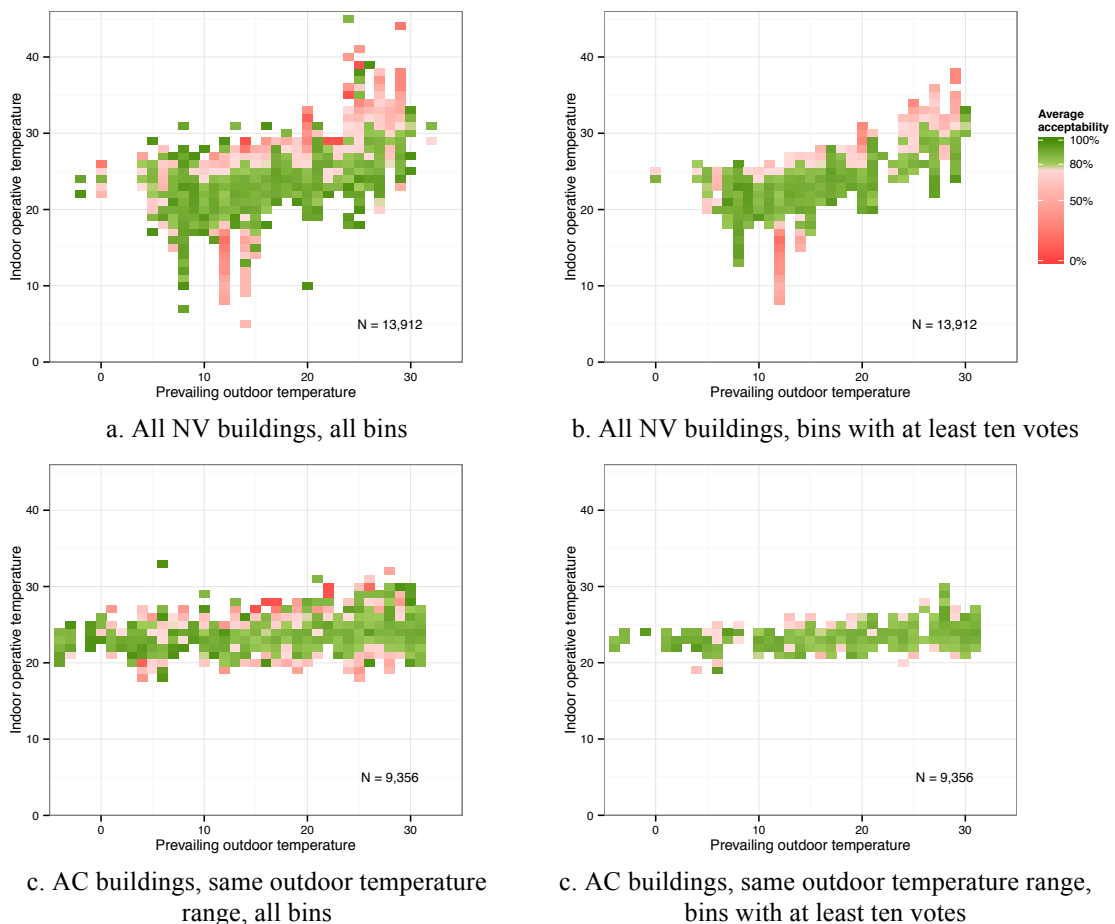

Figure 6. 80% satisfaction zones based acceptability vs. sensation probit analysis

Based on this exploration of the thermal comfort field data, a designer can approach her analysis of her project with fresh eyes. For example, if energy simulation

indicated that the operative temperature sometimes fell to 20 °C inside her proposed building, she is likely to be more concerned if her project has air conditioning than if it does not. In HVAC buildings there is a relatively consistent red line around 20 °C but in NV buildings the lower edge of the comfort zone is left largely undefined (Figure 6 c&d). While this graphical analysis cannot supplant comfort standards (see discussion below), it helps designers put energy simulation results into context.

4 Discussion

The probit analysis that we conducted relating thermal acceptability and comfort votes to thermal sensation provides an evidence-based range of thermal sensation that can provide 80% satisfaction. The results are similar to Fanger's estimate that the middle three thermal sensation categories (-1, 0, 1) represent thermal satisfaction (Fanger, 1982). Because Fanger was using an integer scale, other researchers have adapted the satisfaction range to be -1.5 to 1.5 when using continuous scales (de Dear & Brager, 1998). Our analysis indicates that the range is somewhere in between, but it is unclear how much this is being affected by the fact that many of the studies used integer scales of sensation.

The related tool is a convenient way of exploring the data, as we described above using the example of Honolulu. The danger with such quick statistical analysis, however, is that it's easy to see a curve and come to quick conclusions that may not be justified. For example, only about 3% of the acceptability votes in HVAC buildings occurred under conditions with PMVs outside of the -1 to 1 range. However the tool will fit a probit to this data without giving any indication that the outer ranges of this curve are much less certain than the inner region. To help combat this, we are working on displaying a confidence interval in addition to the simple probit curves.

Our method of visualizing the comfort zone by calculating the percentage of satisfied votes for combinations of indoor and outdoor temperature has both advantages and disadvantages. The best thing about it is that the raw data is translated very directly to the desired information of satisfaction percentage in areas of indoor-outdoor temperature space. This means that we can include data that does not produce a statistically significant regression or we can look at all data without making assumptions about the relationship between thermal sensation and indoor temperature (de Dear & Brager, 1998; McCartney & Fergus Nicol, 2002). Although there is still some uncertainty about how best to define satisfaction, we improve on previous methods by deriving rather than assuming a relationship between thermal sensation and acceptability.

Another advantage of this method is that the visualization technique can be used for small datasets. When no statistical analysis is performed, whatever data is available can be displayed without making assumptions about areas around it where there are no observations. This means that researchers and practitioners can quickly look at and compare subsets of the overall data. While the adaptive model accounts for climatic differences by including outdoor temperature (daily, monthly, running mean), it does not differentiate between cultures, building types, the kinds of adaptive opportunities are available, etc. Using this tool, it is possible to consider only those studies that are most relevant to the project of interest. This is a particular advantage for mixed mode (MM) buildings because there are not very many studies that have been conducted in them.

A significant disadvantage of this method is that it does not give a well defined comfort zone, which makes it less useful for standards and quantitative analysis. We are exploring various machine learning and classification techniques, such as support vector machines and expectation maximization algorithms, to see if they can help overcome this disadvantage.

5 Conclusion

This new way of looking at satisfaction percentages in small bins that are defined by both indoor and outdoor temperature directly evaluates the parameters that are important for the adaptive model and presents them in an easily understandable manner. By allowing users to filter the dataset and get immediate results, the tool we developed can display only the information that is relevant to a particular project. Because this information might be limited and depend on a small sample size that does not allow valid statistical analysis, the fact that this tool is primarily for visualization is an advantage.

This tool is still under development. We hope to allow filtering on more parameters (e.g. presence of operable windows or ceiling fans, the clothing or metabolic rate of the respondents, climate zone) and in a more well implemented way that only displays the combinations that have data available. We want to explore other ways of conducting statistical analysis that builds on this approach of considering satisfaction rates in 2D temperature bins. Eventually, once the tool is further refined, the intention is to make it publicly available on the internet.

Acknowledgement

This study, “Natural ventilation for energy saving in California commercial buildings,” (project 500-10-025) was funded by the California Energy Commission (CEC).

References

- ANSI/ASHRAE 55-2013: Thermal environmental conditions for human occupancy, (2013).
- Arens, E. A., Humphreys, M., de Dear, R., & Zhang, H. (2010). Are “class A” temperature requirements realistic or desirable? *Building and Environment*, 45(1), 4-10.
- Brager, G. S, Paliaga, G., & de Dear, R. J. (2004). Operable windows, personal control, and adaptive comfort. *ASHRAE Transactions*, 110(2), 17-35.
- EN 15251-2007, criteria for the indoor environment including thermal, indoor air quality, light and noise, (2007).
- de Dear, R. J. & Brager, G. S. (1998). Developing an adaptive model of thermal comfort and preference. *ASHRAE Transactions*, 104(1a), 145-167.
- Fanger, P. O. (1982). *Thermal comfort: Analysis and applications in environmental engineering*. Malabar, Florida: Robert E. Krieger Publishing Co.
- Linden, P., et al. (2014). *Natural ventilation for energy saving in California commercial buildings*. California Energy Commission.
- McCartney, K. J. & Nicol, F. J. (2002). Developing an adaptive control algorithm for Europe. *Energy and Buildings*, 34(6), 623-635.

- Nicol, F. & Humphreys, M. (2010). Derivation of the adaptive equations for thermal comfort in free-running buildings in European standard EN15251. *Building and Environment*, 45, 11-17.
- R Core Team (2013). *R: A language and environment for statistical computing*. R Foundation for Statistical Computing, Vienna, Austria. URL <http://www.R-project.org/>.
- RStudio Inc. (2013). *shiny: Web application framework for R*.
- Wickham, H. (2009). *ggplot2: Elegant graphics for data analysis*. Springer New York.
- Zhang, H., Arens, E. A., Fard, S. A., Huizenga, C., Paliaga, G., Brager, G. S., & Zagreus, L. (2007). Air movement preferences observed in office buildings. *International Journal of Biometeorology*, 51(5), 349-360.
- Zhang, H., Arens, E. A., & Pasut, W. (2011). Air temperature thresholds for indoor comfort and perceived air quality. *Building Research & Information*, 39(2), 134-144.

Measure and model of free hanging sound absorbers impact on thermal comfort

Pierre Lombard¹

¹ Saint Gobain Recherche, 39 quai Lucien Lefranc, 93303 Aubervilliers (FR),
pierre.lombard@saint-gobain.com

Abstract

A current trend is to consider that the presence of free hanging sound absorbers (FHU) installed in Thermally Activated Buildings (TABS) reduces the thermal comfort by lowering radiative and convective exchanges with the cooled concrete slab. In this study we propose a simple thermal model of FHU which may be implemented into building simulation software like TRNSys. This model considers convective and radiative exchanges but also the air flows above and below FHU. Experimentally, we observe that a ceiling coverage of 50% leads to a operative temperature increase of 0.3°C. In the same conditions, the proposed model very well agrees with measurements. However, for a coverage ratio of 70%, we measure an increase of 1.0 °C and model 0.5°C. New experiments are currently running to confirm these first results and improve the model.

Keywords : TABS, Thermal comfort, Sound absorbers, Free Hanging Units

1. Introduction

1.1. Position of the problem and goals of this study

Using the thermal inertia of the concrete slab between each floor of a building allows increasing thermal comfort by reducing temperature peaks during the warmest days. The problem is then the accumulation of heat into the concrete. In Thermally Activated Buildings (hereafter TABS), different methods are used to discharge the slab. One of them is the TABS buildings with embedded pipes into the concrete. By flowing cold water inside this pipes, it is possible to remove the heat from the slab.

In such building, occupants and heat sources will exchange with the cooled ceiling by convective (40%) and radiative (60%) processes. Direct radiative exchanges are thus the main thermal exchange process. To increase the efficiency of this kind of activated ceiling, it is thus important to expose to the room the largest possible ceiling surface. However, a large surface of concrete decreases acoustic comfort by increasing sound reverberation. A solution is to install Free Hanging Units (FHU). These are usually 40 mm compressed glass wool mats, attached by a lightweight structure to the ceiling. The ratio of the ceiling surface covered by FHU to the total ceiling surface is defined as the coverage ratio (χ , dimensionless). To maintain radiative exchanges with the room, χ must be strictly lower than 100%, i.e. FHU must not totally cover the activated ceiling.

The problem is that the higher the coverage ratio, the better the acoustic comfort. To the opposite, the higher is the coverage ratio, the lower the surface of exposed concrete. This possibly leads to a reduction of thermal comfort by limiting the possibilities of radiatives or convective exchanges with the activated ceiling. The challenge for building designers or architects is thus to find the best balance between thermal comfort, TABS efficiency and acoustic performance.

The present study has two goals. First, it aims to quantify the impact of FHU on thermal comfort in TABS. Second, it aims to propose a first thermal model of FHU in TABS buildings.

This work has been funded by the Saint Gobain group. Ecophon, a brand of the Saint Gobain group Ecophon also provided the FHU used in experiments.

1.2. Literature on the effect of FHU on thermal comfort in TABS buildings

Several authors studied thermal comfort in TABS buildings (for example: Pfafferott et al, 2007). Influence of FHU acoustic comfort has been also extensively studied (for example: Weitzmann et al. 2009). But to our knowledge, the impact of FHU on thermal comfort has been studied in a limited number of papers, particularly in TABS buildings with embedded pipes.

R. Hoseggen et al. worked on the effect of suspended ceilings on energy performance and thermal comfort in an office building in Norway (Hoseggen et al, 2009). This building is equipped with a hybrid culvert-ventilation but do not have any pipes embedded into concrete slab between each floor. Two rooms were monitored: one with exposed concrete, the other with suspended ceilings. A simulation model of the rooms under ESP-r software is also proposed. In their discussion, authors highlight the difficulty to experimentally quantify the effect of suspended ceilings on indoor temperature. Indeed, in a real building, many parameters like occupant presence in adjacent rooms may affect the thermal behavior of a given office. Then, authors conclude that removing suspended ceiling to expose concrete slightly decreases annual space heating demand (from 3% to 7%). The larger accessible thermal mass allows reducing temperature peaks with more than 1 K during the warmest days. But discharging the additional heat stored into this concrete demands up to 17% higher air volume flow rate outside working hours compared to rooms with suspended ceilings.

H. Peperkamp and M. Vercammen aim in (Peperkamp & Vercammen, 2009) to quantify the reduction of thermal capacity of TABS by FHU. Measurements were made in a climatic chamber equipped with a concrete ceiling cooled by water inside pipes. Several gaps between concrete ceiling and FHU and several coverage ratios (40 to 100%) have been tested. They conclude that the thermal capacity of the concrete is reduced when increasing coverage ratio. Hence, if half of the concrete is covered with a suspended ceiling of 40 mm mineral wool ($\chi = 50\%$), the thermal capacity is reduced by approximately 20%. Moreover, the height of the cavity between the suspended ceiling and the concrete does not seem to significantly reduce the cooling capacity.

Similarly, H. Drotleff et al present a very complete study of absorbers strips on thermal and acoustic comfort in the same kind of TABS buildings (Drotleff et al,

2011). They conclude that covering 20% of the ceiling with strips absorbers leads to an increase of temperature lower than 1°C.

S. Morey et al propose in (Morey et al, 2010) a Computer Fluid Dynamics (CFD) study of effect of perimeter gap width around FHU on the access to thermal mass. Authors define the perimeter gap as the distance between vertical walls and FHU placed in the center of a classroom or of an office. However, the considered building does not have any pipes with water embedded into the concrete slab. Building cooling is only ensured by natural or forced ventilation. Several situations are modeled: different ventilations rates (80 or 160 L/s), different ventilations configurations (single sided or cross ventilated), different FHU configuration (single or double raft) and different heat sources (uniform or discretized). Their results show the tangential speed of air on the ceiling as a function of the perimeter gap. They obtain low air speeds, from 0.042 m.s⁻¹ to 0.16 m.s⁻¹. This speed may be, under some assumptions, linked to the thermal exchange coefficient between room air and concrete ceiling. Authors mainly conclude that, in all cases, increasing the perimeter gap produces a linear increase in mean tangential speed of air across the concrete ceiling for realistic gap sizes. This work was completed in 2012 by a set of additional simulations and measurements (Kershaw 2012). Author concludes first that FHU rafts allow convective heat transfer to thermal mass. He also precise that rafts orientation is crucial. Hence, rafts should be orientated along the short axis of the room to allow creation of convection currents. Ideally, they should be also orientated so that they span the office in the direction perpendicular to ventilation source.

Last, J. Fredriksson and M. Sandberg studied in (Fredriksson & Sandberg, 2009) the effect of false ceiling on the cooling capacity of passive chilled beams. Here, chilled beams are panels with inside flowing cold water. According to the authors, chilled beams are often installed above false ceilings for architectural reasons. Air may then flow from the room to the chilled ceiling through an opening of perforated sheet metal or a grating. But in this case, the cooling capacity of the chilled ceiling may be reduced. Authors measured the cooling power for several FHU positions around chilled ceiling and coverage ratios around chilled ceiling (from 0 to 100%). In all experiments, the chilled ceiling was never covered by the FHU. They conclude that going from a totally covered ceiling (except chilled beam area) to a totally uncovered ceiling leads to an increase of cooling capacity from 45% to 61%. FHU thus clearly affect the cooling capacity of chilled ceiling. But these results also demonstrate that the positions of the FHU relative to the walls are very important. In the case of a large uniform heating source on the floor with a chilled ceiling located in the center of the ceiling, the cooling capacity will be influenced by the size of the perimeter gap, as previously defined by S. Morey in (Morey et al, 2010).

Overall, despite this very limited number of papers, authors agree on an impact of FHU on indoor air temperature lower than 1°C, even for the highest ceiling coverage ratios. The precise effect depends on the configuration of FHU in the room and particularly to the horizontal distance between the wall and the FHU.

2. Quantification of thermal comfort in a real TABS building with FHU

The goal of these measurements was to quantify the impact of ceiling coverage ratio on the thermal comfort in a real TABS building. The complete results of these

measurements have already been published elsewhere (Le Muet et al., 2013). We'll thus only remind here the most important results.

2.1. Description of the experimental facility

The WOOPA tower is a TABS building with embedded pipes located in the suburbs of Lyon (FR). In this building, two rooms facing south-east at the same floor were used for experiments. Both approximately measure $4.3 \times 4.2 \times 2.8 \text{ m}^3$. The facade of the building is constructed of wooden profiles, with approximately 50% of triple glazing containing inside built-in blinds. During all the experiments, the blinds were half open, half closed. In the first room ('reference room') no suspended ceiling was applied during all the measurements. In the other ('test room'), no FHU were applied for 8 days in June, 2012. During this period, air and operative temperature were recorded into both rooms in order to compare their thermal behavior. Then, FHU with two ceiling coverage ratios (50% and 70%) were installed into the test room. The suspended ceilings used were $1.2 \times 1.2 \times 0.040 \text{ m}$ thick glass wool ceilings panels from Saint Gobain Ecophon. As shown on figure 1, a cavity of $\sim 220 \text{ mm}$ is placed between the FHU and the ceiling. Two electric heating elements (180 W each) were placed into each room to simulate the presence of occupants during the day (8:00 – 18:00) as described in DIN EN 14240.

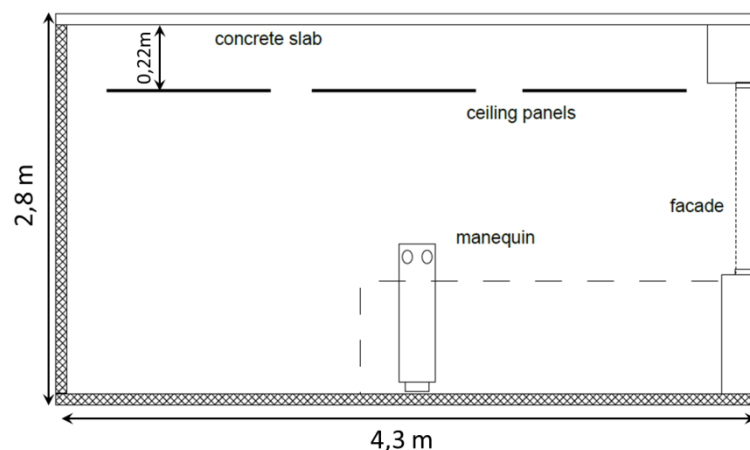

Figure 1: Sketch of the test room in the WOOPA tower

2.2. Results

The two rooms do not have exactly the same thermal behavior: the measured operative temperature in both differs by less than 1°C . This may be explained by several parameters and corresponds to the difficulties underlined by (Hoseggen et al, 2009). However, a more detailed analysis of the results allows Peperkamp to conclude that a ceiling coverage ratio of 50% by FHU leads to an increase of operative temperature inside the rooms by $\sim 0.3 \text{ K}$. And increasing the coverage ratio to 70% is traduced by an increase of operative temperature of $0.8\text{-}1.0 \text{ K}$. These values are in the range of the previous works published in literature. Unfortunately, the impact of FHU orientation or perimeter gap has not been measured.

3. Thermal model of free hanging units

3.1. Scope and limitations of the model

For research or commercial purpose, it is important to evaluate thermal comfort and energy performance of buildings before their construction. TRNSys (TRaNsient SYstem Simulation) is a simulation environment widely used by researchers, thermal consultants or architects to model the dynamic thermal behavior of a building. In TRNSys, buildings are represented by a component called Type 56 (Bradley, 2009). However, TRNSys is today not able to model a ceiling partially covered with FHU. Our goal is thus to propose here a physical model of FHU compatible with the physical description of buildings used in software like TRNSys.

Under TRNSys, a building is divided into thermal zones which are assumed to have the same thermal behavior. Each thermal zone is limited by building surfaces like walls, ceilings, floor, glazing, etc. For example, a thermal zone may represent one room. These thermal zones are themselves divided into one or more thermal air nodes. An air node represents a volume of air which is assumed to be perfectly mixed and characterized by one temperature (Bradley 2009). Under TRNSys, each node is linked to the others through a set of thermal resistances and capacitances. These thermal resistance or capacitance model the physical exchanges in the building: conductive, convective or radiative exchanges with air or surfaces, thermal inertia, etc.

In the present model, we thus consider a room from a TABS building covered with a given amount of FHU as a unique thermal zone. This room is divided into two air nodes by the layer of FHU. The first air node represents the volume of air located below FHU and including building occupants, furniture, etc. The second air node represents the air volume located above FHU. According to TRNSys conventions, both are assumed to be perfectly mixed and temperature homogenous. But because the ceiling is not totally covered by FHU, both air nodes will exchange air thanks to natural or forced convection processes. Occupants and surfaces will also exchange with the ceiling by radiative processes. Two boundary situations must be considered. The first one, represented on the left of figure 2, is a ceiling totally covered by FHU ($\chi = 100\%$). In this situation, there is a convective exchange between the air of each air node and the surrounding surfaces. If we consider the lower air node, these are for example the floor and the lower face of FHU. There is also a radiative exchange between FHU surfaces and floor and ceiling. However, in this situation, we assume that the ceiling is perfectly tight, i.e. there is not any air flow between the two air nodes. Last, it exists a direct conductive exchange through the FHU.

The second boundary situation, represented on the right of figure 2, is a ceiling not covered by FHU ($\chi = 0\%$). In this situation, there is a convective exchange on one hand between the air of the upper node and the TABS ceiling and on the other hand between the air of the lower node and the floor. There is a direct radiative exchange between the TABS ceiling and the floor. And in this case, there is an air flow exchange between the two air nodes. Its intensity depends on the ceiling coverage ratio, on the temperature difference between lower and upper nodes and on the presence in the room of a mechanical ventilation system.

As depicted on figure 2, each convective or radiative exchanges in these two boundaries cases may be represented by a thermal resistance. The value of these

thermal resistance depend on the thermal nodes temperatures, on the intensity of the convective or radiative exchange and on the surface temperatures. However, because TRNSys assumes each air node as perfectly mixed, it is not possible to precisely compute the repartition of air flows and temperature in the room. Any intermediate ceiling coverage ratio ($0 < \chi < 100$) is thus assumed to be an intermediate situation which may be traduced by a linear combination of the thermal resistances obtained in the two previous boundary cases.

In literature, some previous studies already proposed to model under TRNSys rooms with several air nodes. This gave for example the COwZ software (Stewart & Ren, 2006). Unfortunately, these model where not able to take into account the presence of solid elements like FHU between to sub-nodes into the room.

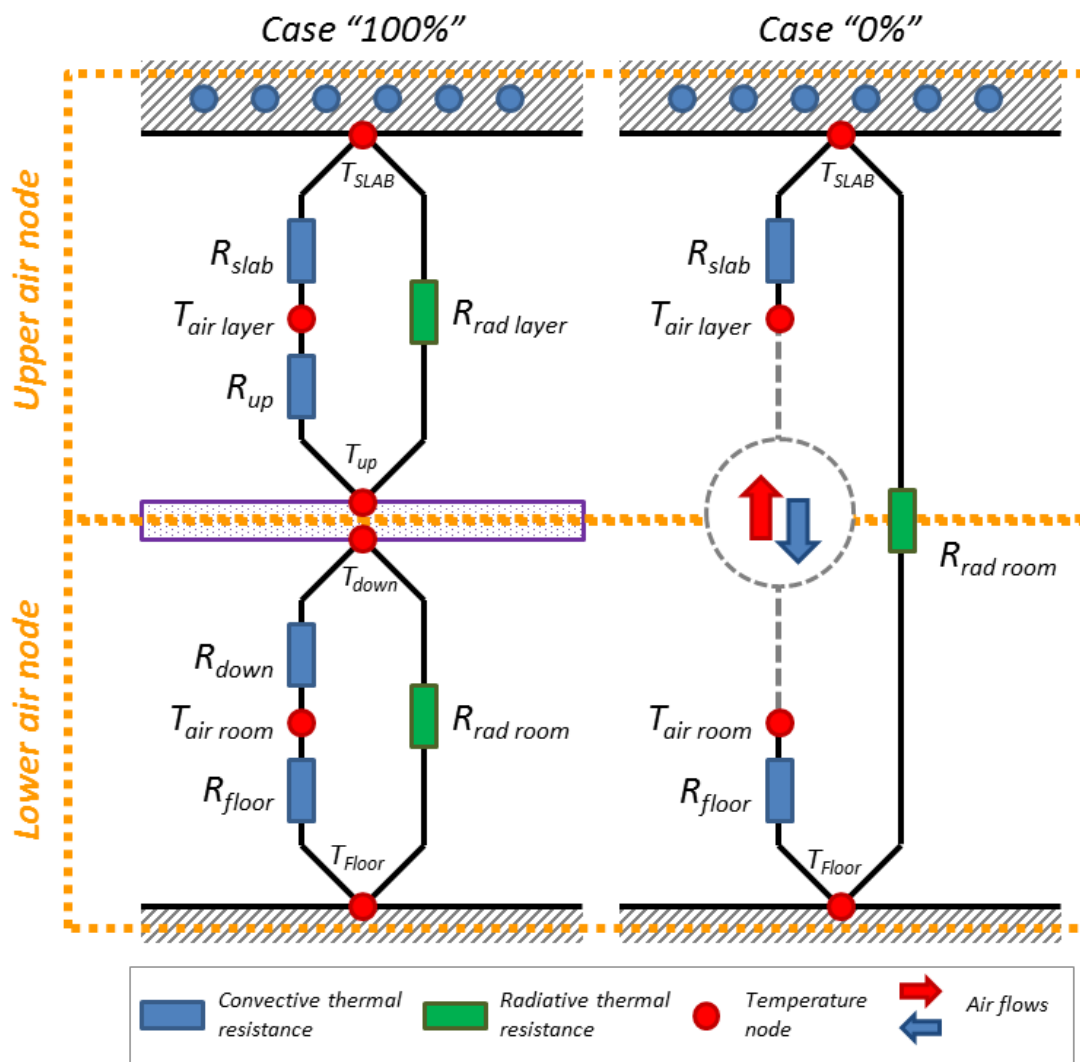

Figure 2. General overview of FHU thermal model

3.2. Modeling air flows through horizontal partitions

TRNSys proposes several ways to take into account airflows on an air node: infiltrations, mechanical ventilation or the so-called coupling. An infiltration represents the air flow entering in a building which is not perfectly air-tight. It will

depend on building orientation and wind speed. Mechanical ventilation represents an air flow imposed by a mechanical system like a cooling device or a fan. Last, a coupling represents the air flow due to natural convection between two air nodes one above the other. The problem is that TRNSys is not able to compute itself the intensity of each kind of air flow. The value must be given by the user. Between 1988 and 1997 an international collaboration in the frame of the IEA Annex 23, the Lawrence Berkley National Laboratory (LBNL, USA) and then the International Energy Agency (IEA) developed and experimentally validated the software COMIS acronym of Conjunction Of Multizone Infiltration Specialists (Feustel & Raynor-Hoosen, 1990). Coupling TRNSys and COMIS has been allowed thanks to the development of a special component called Type 157. With this Type, it is possible to model in the same simulation the thermal and the airflow behavior of a building. Since its version 17, TRNSys directly integrates COMIS in a new extension called TRNFlow. TRNFlow associates an air pressure to each air node. Each node is linked to the others by a set of non-linear conductances which model air paths. These conductances may represent windows, doors, walls, cracks, etc. In the case of FHU in a room, we want to model upward or downward air flows through the spaces between FHU, i.e. through horizontal openings. Unfortunately, COMIS nor TRNFlow are able to do it. This is mainly because, at the time of the creation of COMIS, too few scientific studies on vertical flows through horizontal openings were available to obtain an acceptable physical model (Feustel, 1990). This limitation stayed in TRNFlow.

We thus identified in literature three interesting studies which may be used to model upward or downward air flows through horizontal openings. The first is M. Epstein's pioneer work (Epstein, 1988) who studied the buoyancy-driven exchange flow through small openings in horizontal partitions. In his experiments, he used two tanks separated by a tube of diameter D (in m) and length L (in m). One tank contains clear water when the other contains a solution of brine water. The two compartments thus have a different density. M. Epstein measured the exchange rate between the two compartments for several L/D ratios and for two types of openings shapes: circular or square. Then, he plotted the Froude number Fr as a function of the L/D ratio. M. Epstein shows that four regimes exist and gave a general equation to describe them. This equation is valid for $0.01 < L/D < 20$ and $0.025 < \Delta\rho/\bar{\rho} < 0.17$ where $\Delta\rho$ is the density difference and $\bar{\rho}$ is the average density of the two compartments.

In a second interesting work is the study of L. Zhigang who studied in his PhD thesis the characteristics of buoyancy driven natural ventilation through horizontal openings (Zhigang, 2007). His experiments were carried out in a full-scale test cell divided in two rooms. He studied by velocity field measurements, air flow rate measurements and smoke visualization the characteristics of the air flow due to natural convection between the two rooms. L. Zhigang first concludes that the air flow through horizontal openings is bidirectional (upward and downward), highly transient and complex. Moreover, he mainly confirms that the four regimes identified by M. Epstein in brine water may be applied for air flows through horizontal openings in buildings.

If we consider a room of 18 m² like in the WOOPA tower covered with 70% of free hanging units, we obtain a total area uncovered by FHU of 5.4 m². Using Zhigang notations, this is equivalent to a circle characterized by a diameter of $D = 2\sqrt{5.4/\pi} = 2.622$ m. Knowing that a classical sound absorber has a thickness of $L=0.04$ m, we obtain a L/D ratio of 0.0152. This is comprised in the limits of M. Epstein's and L.

Zhigang models. However, despite their great interest, these two works are not the most adapted to model the air flow from/to the room from/to the air layer above FHU. Indeed, L. Zhigang only studied the case where the lower air volume is warmer than the upper one. Second, he does not take into account the effect of any mechanical ventilation.

S. Vera proposes in his PhD thesis a third numerical and experimental study of air and moisture transport through large horizontal openings (Vera, 2009). His experimental facility consists in two rooms, one above the other. Their temperature may be independently controlled. Both possess also ventilation inlets, ventilations outlets and a moisture source. All may independently be open or closed. The two rooms communicate through an opening with a surface of $0.91 \times 1.19 = 1.08 \text{ m}^2$ and a thickness of 0.22 m. Knowing that the slab between the two rooms measure 8.83 m^2 , we conclude that this opening covers 12% of the total floor surface. S. Vera measured the air flow between the two rooms for several temperatures differences, with or without mechanical ventilation and for several ventilations air speed. He deduces two empirical relations which express the intensity of air flow $F_{lower\ to\ upper}$ (in kg.s^{-1}) from the lower room to the upper room in case of natural or mixed convection.

$$F_{lower\ to\ upper} = C\rho A\sqrt{gd}\left(\frac{\Delta T}{\bar{T}}\right)^n$$

$$F_{lower\ to\ upper} = C\rho A\sqrt{gd}\left(\frac{\Delta T}{\bar{T}}\right) + b$$

where C , n and b are empirical coefficients, ρ is air density (kg.m^{-3}), A is opening area (in m^2), g is gravity acceleration (m.s^{-2}), d is the vertical thickness of the opening (m), T_{lower} and T_{upper} are the air temperature in the lower and upper rooms (both in $^{\circ}\text{C}$), $\Delta T = T_{lower} - T_{upper}$ is the temperature difference between rooms (in $^{\circ}\text{C}$) and $\bar{T} = (T_{lower} + T_{upper})/2$ is the mean temperature between rooms (expressed in $^{\circ}\text{C}$). Depending on the scenario or the temperature difference between rooms, the quantity $F_{lower\ to\ upper}$ may be thus positive or negative. From his experiments as well from numerical simulations, S. Vera gave in (Vera, 2009) and in (Vera et al 2010) the values of the C , n and b coefficients for several airflows rates.

Because the work of S. Vera is valid for buildings, for large openings, with or without ventilation, with positive or negative temperatures differences on both sides of FHU, we conclude that it is the most adapted to model airflows across FHU for ceiling coverage. However, we must underline that S. Vera does not vary the opening area or thickness. His expressions for air flow $F_{lower\ to\ upper}$ depends on a factor $\left(\frac{D}{2}\right)^2\sqrt{d}$ when the relation from M. Epstein and L. Zhigang, obtained on smaller openings, depends on a factor $\sqrt{D^5}$. This point has to be studied for the next versions of the model.

3.3. Convective exchanges

Three different cases must be considered as a function of mechanical ventilation intensity: natural convection (without mechanical ventilation), mixed convection (low mechanical ventilation) or forced convection (high mechanical convection). To discriminate each case, we compute first the value of the Richardson number defined by:

$$Ri = \frac{g\beta(T_s - T_\infty)L}{V}$$

Where T_∞ (in K) is the fluid temperature, T_s is the surface temperature (in K), β the thermal expansion coefficient of air (in K, computed by $\beta = 1/T_\infty$) and V is air velocity (in m.s^{-1}). If $Ri \gg 1$ (i.e. $Ri > 10$ for code implementation) or if there is no mechanical ventilation ($V = 0 \text{ m.s}^{-1}$), we are in a situation of natural convection. If $Ri \ll 1$ (i.e. $Ri < 0.1$ for code implementation), we are in a situation of forced convection. Else, we are in a mixed convection situation.

For each situation, we propose below a relation to compute Nu , the Nusselt number on the surface. The thermophysical properties of air are taken in the tables proposed by (Incropera et al, 2009). From the Nusselt number, we can compute the convective exchange coefficient h_{conv} (in $\text{W.m}^{-2}.\text{K}^{-1}$) of air on the surface by:

$$h_{conv} = \frac{Nu\lambda}{L}$$

Where λ is the air thermal conductivity ($\text{W.m}^{-1}.\text{K}^{-1}$) and L is the characteristic length of the plate (in m), defined by $L = A/P$ with A the area (m^2) of the plate and P (m) its perimeter. In the present model, if we consider the upper air node, the surface will be for example the upper face of the FHU. In this case, A is the total area of the FHU and P its perimeter. Last, we obtain the value of the thermal convective resistance R (expressed in $\text{W}^{-1}.\text{m}^2.\text{K}$) shown on figure 2 by computing:

$$R = \frac{1}{h}$$

3.3.1. Natural convection

In case of natural convection many authors proposed in literature empirical relations to express the convective exchanges coefficients on horizontal surfaces as a function of surface and air temperature. Incropera et al gives in (Incropera et al, 2009) a good summary. If cold fluid falls on the upper surface of a hot plate ($T_\infty < T_s$) or if warm fluid exchange with the lower surface of a cold plate ($T_\infty > T_s$), then the Nusselt number is expressed by:

$$Nu_L = 0.54Ra_L^{1/4} \quad \text{for } 10^4 \leq Ra_L \leq 10^7$$

$$Nu_L = 0.15Ra_L^{1/3} \quad \text{for } 10^7 \leq Ra_L \leq 10^{11}$$

Ra_L is the Rayleigh number (dimensionless) defined by:

$$Ra_L = \frac{g\beta(T_s - T_\infty)L^3}{\alpha\nu}$$

Where α is the air thermal diffusivity ($\text{m}^2.\text{s}^{-1}$) and ν is the air kinematic viscosity ($\text{m}^2.\text{s}^{-1}$). If on figure 2 we consider the upper air node, we'll have $T_\infty = T_{air\ layer}$ and $T_\infty = T_{air\ room}$ for the lower air node. According to the situation, the surface temperature T_s may be T_{down} , T_{up} , T_{slab} or T_{floor} .

3.3.2. Mixed convection

In case of a mixed convection, we use the relation proposed by Taine et al for a horizontal plate submitted to an isotherm air flux (Taine et al, 2008):

$$Nu_L = 2F_1\sqrt{Re_L} \left[1 + \left(\frac{5F_3 \left(\frac{Gr_L}{Re_L^{5/2}} \right)^{1/5}}{6F_1} \right)^3 \right]$$

Where Re and Gr_L are the Reynolds and the Grashof numbers and F_1 and F_3 are two parameters computed by:

$$F_1 = 0.399Pr^{1/3} \left[1 + \left(\frac{0.0468}{Pr} \right)^{2/3} \right]^{-1/4}$$

$$F_3 = \left(\frac{Pr}{5} \right)^{1/5} Pr^{1/2} \left(0.25 + 1.6Pr^{1/2} \right)^{-1}$$

Where Pr is the Prandtl number for air. In the present study, we assume a constant value of $Pr = 0.71$ (Incropera et al, 2009).

3.3.3. Forced convection

The case of a forced convection may arise for higher ventilations, if the ventilation inlet is directly in the ceiling and thus connected with the upper air node. In this case, we use the relation proposed by (Incropera et al, 2009) :

$$Nu_L = 0.664Re_L^{1/2}Pr^{1/3}$$

Which is valid for $Pr > 0.6$, i.e. valid in the present case ($Pr = 0.7$ for air).

3.4. Radiative exchanges

Because we consider a real building, we assume that the temperature differences between each surface are low, i.e.

$$T_{down} - T_{floor} \ll T_{floor} \quad \text{or} \quad T_{up} - T_{slab} \ll T_{slab}$$

Under these conditions, we can linearize the expression of the radiative flux (Taine et al, 2008) and compute the value of the radiative exchange coefficient h_{rad} by:

$$h_{rad} = 4\varepsilon_{eq}\sigma T_m^3$$

Where s is the Stefan-Boltzmann constant, T_m is the average temperature of the two surfaces considered and ε_{eq} is the equivalent emissivity of the two surfaces. To compute its value, we assume two infinite surfaces characterized by emissivities ε_1 and ε_2 (both dimensionless) and we use (Incropera et al):

$$\varepsilon_{eq} = \frac{1}{\frac{1}{\varepsilon_1} + \frac{1}{\varepsilon_2} - 1}$$

Knowing the value of the radiative exchange coefficient, we compute the value of the thermal radiative resistance R_{rad} (in $W^{-1}.m^2.K$) by:

$$R_{rad} = \frac{1}{h_{rad}}$$

3.5. Conductive exchanges

In the present model, thermal flux may also pass through the FHU (not shown on figure 2). We compute the thermal conductive resistance R_{cond} (in $W^{-1}.m^2.K$) by:

$$R_{cond} = \frac{e_{FHU}}{\lambda_{FHU}}$$

Where e_{FHU} is FHU thickness (m) and λ_{FHU} is FHU thermal conductivity (expressed in $W.m^{-1}.K^{-1}$).

3.6. Numerical solution and implementation of the model

All the equations of the model are implemented in a plug in for TRNSys. The total equation system is solved using the Trust-Region Dogleg method. This plug-in and its source code are freely available upon request to the corresponding author.

4. Validation of the model

We built a model of the two WOOPA rooms under TRNSys. This case uses the same room geometry, occupancy, etc. Ceiling coverage by FHU was simulated using the plug in developed in this study. We used typical weather files from Lyon (FR) and not real weather data. Running the simulation for June, July and August months allows us to simulate the operative temperature in the rooms.

With 50% ceiling coverage, we obtain an average increase of 0.33°C of the operative temperature. With 70%, this increase is 0.50 °C. The value obtained in the case of 50% ceiling coverage agrees very well with the measurements. However, the value obtained in the case 70% ceiling coverage is under evaluated.

Even if these results are good, the assumptions made during measurements and model forbids making additional conclusions. To precisely validate the model presented here as well to validate measurement results, a new experimental campaign is on-going.

5. Conclusion

Installing Free Hanging Units (FHU) on the ceiling of a Thermally Activated Building (TABS) improves acoustic comfort but will modify thermal comfort. Literature review and our measurements show that the impact on black globe temperature depends on ceiling coverage ratio, FHU orientation and distance between walls and FHU. It may reach 1°C for 70% ceiling coverage ratio and 0,3°C for 50% ceiling coverage ratio . The impact of FHU on thermal comfort thus exists but it is limited.

To better evaluate the interest of FHU in TABS buildings, we propose here a thermal model of FHU. This model was implemented in a plug-in for the thermal simulation software TRNSys. A first experimental validation shows the interest of this model, particularly for medium ceiling coverages (50%). For higher ceiling coverage (70%), the model slightly underestimates the increase of operative temperature. However, new measurements in a lab are currently on-going to complete model validation.

6. Acknowledgements

We sincerely thank Pierre Chigot, Yoan Le-Muet, Ricardo Canto Leyton from Saint Gobain and Hanneke Peperkamp from Peutz laboratory for their kind help.

References

Bradley, D. et al., 2009, TRNSys 17 user manual

Drotleff H.; Wack, R. Leistner, P.; Holm A. Ziegler, M. and Sedlbauer, K.2011. Integrated sound absorption in thermally activated concrete ceilings - acoustic and thermal effectiveness of sound-absorber strips spaced at intervals; *Bauphysik*; 33 (5) pp 274-286

Epstein, M. 1988. Buoyancy-driven exchange flow through small openings in horizontal partitions, *Journal of Heat Transfer*, 110, 885-893

Feustel, H. & Raynor-Hoosen, A. 1990. *Fundamentals of the multizone air-flow model – COMIS*, International Energy Agency - energy conservation in buildings and community systems program

Fredriksson, J. & Sandberg, M. 2009. The effect of false ceiling on the cooling capacity of passive chilled beams, *Building and Environment*, 44, pp 1426-1430

Hoseggen, R.; Mathisen, H. & Hannsen, S. 2009. The effect of suspended ceilings on energy performance and thermal comfort *Energy and Buildings*, 41, pp. 234-245

Incropera F.; Dewitt, D.; Bergman, T. & Lavine, A. 2007. *Fundamentals of Heat and Mass Transfer* Wiley

Kershaw, T., 2012. *Assessing thermal mass in Cornwall Council offices* Centre for Energy and Environment Innovation, University of Exeter.

Le Muet, Y; Peperkamp, H; Machner, R; 2013. Combining thermally activated cooling technology (TABS) and high acoustic demand: Acoustic and thermal results from field measurements *Inter-Noise, International Congress and Exposition on Noise Control Engineering*, Innsbruck, 15–18 September 2013.

Morey, S.; Coley, D. & Kershaw, T. 2010. Assessing the thermal mass above suspended ceilings via a perimeter gap: a CFD study of natural ventilated spaces *International Journal of Ventilation*, 9, pp 163-175.

Peperkamp H. and Vercammen M. 2009. Thermally activated concrete slabs and suspended ceilings, *NAG-DAGA International conference*, Rotterdam

Pfafferott, J.; Herkel, S.; Kalz, D. & Zeuschner, A. 2007. Comparison of low-energy office buildings in summer using different thermal comfort criteria *Energy and Buildings*, 39, pp. 750-757

Stewart, J. & Ren, Z. 2006. COwZ - A subzonal indoor airflow, temperature and contaminant dispersion model *Building and Environment*, 41, pp 1631-1648

Taine, J.; Iacona, E. & Petit, J. 2008. *Transferts thermiques - Introduction aux transferts d'énergie* - 4ième edition Dunod

Vera, S. 2009. *Interzonal Air and Moisture Transport through Large Horizontal Openings: An Integrated Experimental and Numerical Study*. Concordia University.

Vera, S.; Fazio, P. & Rao, J. 2010. Interzonal air and moisture transport through large horizontal openings in full-scale two-story test-hut: Part 2 - CFD Study, *Building and Environment*, 45, pp 622-631.

Weitzmann, P.; Pittarello, E.; Olesen, Bjarne W. 2009. The cooling capacity of the thermo active building system combined with acoustic ceiling, *Nordic Symposium on Building Physics*, Kongens Lyngby

Zhigang, L. 2007. *Characteristics of Buoyancy Driven Natural Ventilation through Horizontal Openings*. PhD thesis, Aalborg University

Evaluating the influence of thermal mass and window size in a direct gain system on the annual and lifetime energy consumption of domestic Australian light weight construction

Authors: Ben Slee¹, Anir Upadhyay¹, Richard Hyde¹

¹University of Sydney, email: ben.nj.slee@gmail.com

Abstract

Climate responsive design ensures thermal comfort in buildings without using excessive energy for heating and cooling. This study explores how the relationship between the quantity of north (equator) facing window area, the quantity of thermal capacity and the distribution of thermal capacity in a space can improve comfort and energy efficiency in residential buildings in Australia, and optimise lifetime CO₂-e emissions. The study concludes that thermal capacity can improve the thermal efficiency of the simulated structure, primarily through its influence on annual cooling loads. A direct gain system is only appropriate for the climate in Penrith. Thermal capacity should be used in Melbourne and Brisbane to mitigate summer overheating. When lifetime CO₂-e emissions are calculated no single configuration in any particular climate emerges as the optimal solution. The results suggest that it would be useful to explore further modifications to the fabric and form of the building in each climate.

Keywords: Thermal capacity, window size, embodied energy

1.0 Introduction

There are numerous factors that affect thermal comfort in a building. Climate responsive design ensures thermal comfort in buildings without using excessive energy for heating and cooling. Design decisions are made in response to the local climate which also influences our perception of thermal comfort (de Dear and Brager, 1998). An optimum design uses the orientation and organisation of the house on a site, the judicious placement and sizing of openings, insulation, ventilation and thermal capacity to create and maintain thermal comfort. This study explores how the relationship between the quantity of north (equator) facing window area, the quantity of thermal capacity and the distribution of thermal capacity in a space can improve comfort and energy efficiency in residential buildings in Australia. The analysis focuses on three climates in Australia's three largest population centres.

Thermal capacity stores and then releases thermal energy thus helping to stabilise the temperature range inside a building. Adding thermal capacity also means increasing the embodied energy of the construction system. A lightweight construction system, particularly if it uses timber products, contains significantly less embodied energy

than a heavyweight construction system using concrete and bricks (Hammond and Jones, 2008, Chen, 2010).

1.1 Australian lightweight construction

Domestic construction is dominated by lightweight and brick veneer construction systems. In terms of thermal performance brick veneer behaves in a very similar way to lightweight construction (Gregory et al., 2008, Sugo, 2004). The internal temperature of lightweight buildings tends to follow the external temperature profile. The use of domestic air-conditioning is increasing rapidly up from 59% in 2005 to 73% in 2011 (Australian_Bureau_of_Statistics, 2011), in turn this will lead to a significant increase in domestic CO₂ emissions since 96% of Australia’s energy comes from carbon based resources (BREE et al., 2013).

1.2 Australian Climates

There are a broad range of climates in Australia ranging from cool temperate in the south to tropical in the north. Australia’s three largest cities, Melbourne, Sydney and Brisbane, and the majority of the population are located on the east and south east coast. The three cities experience three different climates described in summary below. The climate data used for these descriptions was obtained from the Australian Bureau of Metrology (www.bom.gov.au). The comfort zone plotted on the temperature charts is defined by the adaptive comfort model with 80% acceptability (ASHRAE, 2010).

1.2.1 Melbourne

Melbourne’s climate (Figures 1 & 2) is cold and cloudy in winter; and warm, sometimes very warm or hot in summer. In the cooler half of the year the mean daily maximum temperature falls below the comfort zone with 10% of minimum temperatures (decile 1) below 5°C. Winter is cloudy with mean daily sunshine hours below 4. In the warmer half of the year the mean maximum temperature is within the comfort zone but the mean minimum temperature remains below the comfort zone. In summer extreme temperatures are experienced with 10% (decile 9) of maximum temperatures above 35°C in January and February (decile 9 - 35.6 and 34.7 °C). The mean diurnal range ranges from 7.2 degrees-C in June (winter) to 11.6 degrees-C in January (summer). Summer skies are predominantly cloudy.

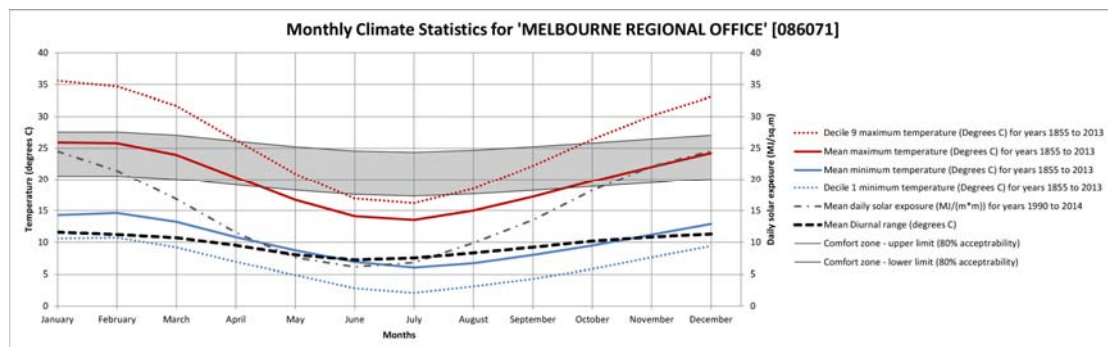

Figure 1. Annual temperature data for Melbourne

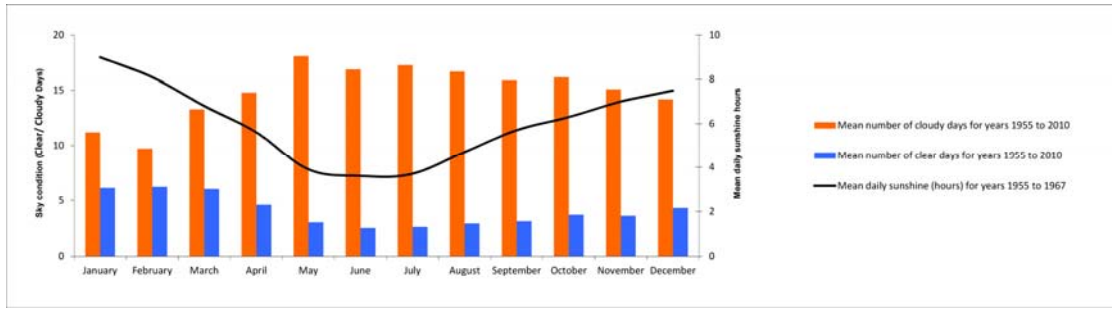

Figure 2. Annual sunshine data for Melbourne

1.2.2 Penrith (Sydney)

The climate in Sydney (figures 3 & 4) becomes significantly more extreme as the distance to the east coast increases. Penrith is about 30km from the coast. Penrith experiences hot summers, warm winter days with cool or cold winter nights. The mean maximum temperature is within the comfort zone for 9 months of the year, rising just above it in December and January and falling just below in July. More than 10% of maximum temperatures exceed 35 °C in December, January and February. In the cooler months of the year the minimum temperature falls below 5 °C more than 10% of the time between May and September. The winter sky is relatively clear and mean daily hours of sunshine remain high throughout the year. The mean daily diurnal variation is above 10 degrees-C throughout the year.

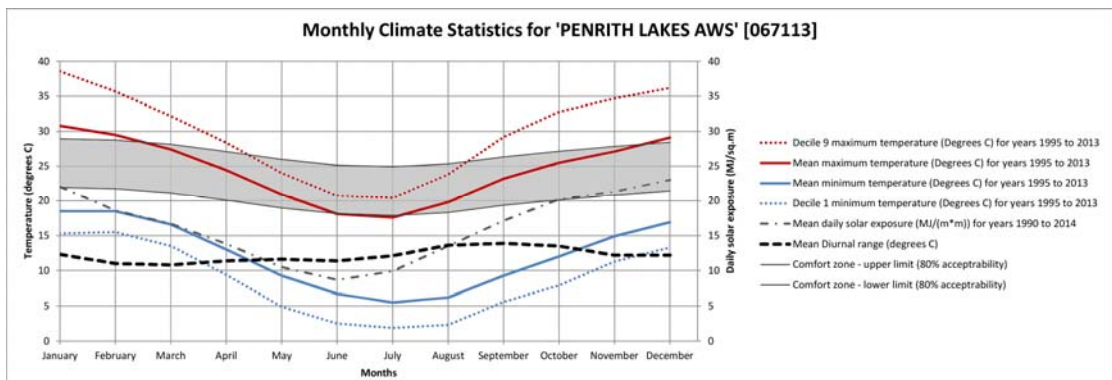

Figure 3. Annual temperature data for Penrith (Sydney)

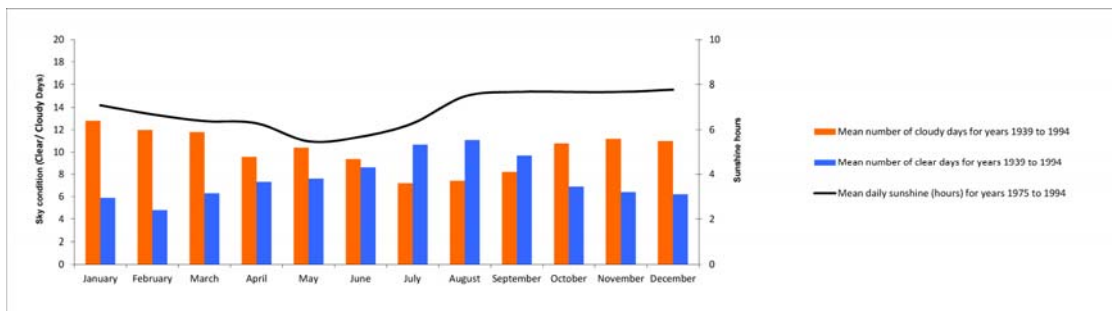

Figure 4. Annual sunshine data for Penrith (Sydney)

1.2.3 Brisbane

Brisbane's climate (figures 5 & 6) is warm and humid in summer and cool in winter. The mean maximum temperature remains within the comfort zone throughout the year ranging from the upper limit in summer to the lower limit in winter. The mean minimum temperature is below the comfort zone throughout the year falling to below 10 °C in July. More than 10 % of the minimum daily temperatures are below 10°C between May and September. The summer is dominated by cloudy and rainy days. Winter days are generally clear. Mean daily sunshine hours remain high throughout the year and rise in the winter and spring months. The maximum temperatures in summer are modest compared to the other two climates. The Mean daily maximum temperature does not exceed 30 °C and the highest recorded decile 9 temperature is 32.7 °C in January. The mean diurnal range varies from 8.7 degrees-C in January to 11.5 degrees-C in August.

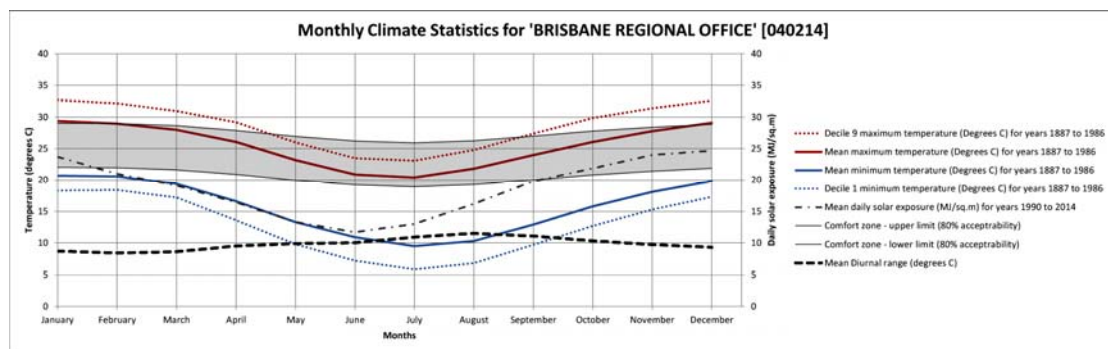

Figure 5. Annual temperature data for Brisbane

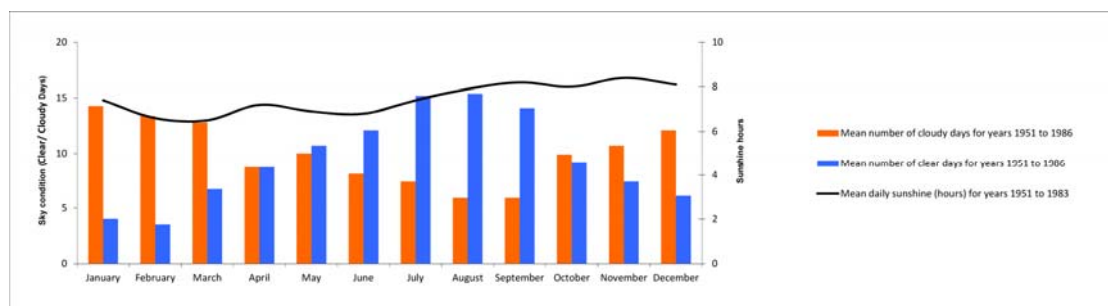

Figure 6. Annual sunshine data for Brisbane

2.0 Form and fabric

2.1 Design guidance

Design guidance promotes the use of thermal capacity in order to reduce energy consumption and increase comfort (Reardon, 2001, Hollo, 1986) (www.thinkbrick.com.au). This advice is qualitative rather than quantitative with little advice for designers interested in understanding how much thermal capacity is needed or where that capacity might best be located in the space (Slee and Hyde, 2011).

2.2 Direct gain systems

The design guidance proposes the use of a direct gain (or passive solar) system in all of the three climates being considered in this paper. In winter a direct gain system uses the thermal energy storage properties of thermal capacity to absorb solar energy during the day and then release that energy during the evening and night to help keep the space warm. During summer the windows are shaded to avoid sunlight entering the space directly and the thermal capacity is expected to absorb thermal energy from the air helping to lower the ambient air temperature. This thermal energy is dissipated using cool evening breezes.

2.3 Windows

The size, orientation and shading of the window is critical to this direct gain strategy since it controls both the quantity of solar energy allowed to enter the space and the ventilation of the space. A number of authors provide “rules of thumb” relating window area to the quantity of thermal capacity in a space assuming that the thermal capacity is on the floor. Evidence to support the suggestions is not provided and the suggested rules themselves vary widely between authors (Baggs and Mortensen, 2006, Greenland and Szokolay, 1985, Oppenheim, 2007) (table 1).

Table 1. Recommended north (equator facing) glazing area as a percentage of floor area

	(Greenland and Szokolay, 1985)	(Baggs and Mortensen, 2006)	(Oppenheim, 2007)
Brisbane	20-25% floor area	9.5%	-
Sydney		15.5%	-
Melbourne		13.5%	15–20% floor area

2.4 Ventilation

In passive and mixed mode systems ventilation is used to cool the fabric of the building and to provide sensible or comfort cooling for the occupants. In order to cool the fabric of the building a night ventilation strategy is employed. Shaviv et al(2001)has shown that the influence of the rate of ventilation on temperature follows a law of diminishing returns. Shaviv also finds that a minimum external diurnal temperature swing of 6°C is required for the strategy to be effective with good night ventilation (20 air changes per hour), Givoni (1998)suggests that the diurnal range should be 10°C. Kivva et al(2009) has shown that there is an optimum air speed around 2.5m/s for removing thermal energy from the fabric. Above and below this speed the removal of thermal energy becomes less efficient. La Roche and Milne (2004) carried out a series of experiments with two test cells in Los Angeles, California where they varied the thermal capacity, window size and ventilation method during summer months. They showed that an “intelligent” ventilation system that only ventilates the space when the outside air temperature is cooler than the internal air temperature is significantly more effective than continuous ventilation. They also showed that reduced solar penetration (smaller windows) and increased thermal capacity improves the thermal performance in the summer.

What these periodic ventilation methods fail to deal with is the need for some ventilation when a space is occupied in order to maintain adequate air quality and, during warmer weather, provide sensible cooling (ASHRAE_2010_Addendum_D, 2012, Toftum, 2004). In Australia, with the cultural emphasis on outdoor living, opening doors, windows and natural ventilation are an important part of any house design. This ventilation brings warmer air into a space that will, through convection and conduction warm up the fabric. In warm weather natural ventilation can also bring delight to the thermal experience because of its natural variation – the breeze (Xia et al., 2000, Zhao, 2007, de Dear, 2010).

2.5 Thermal capacity vs. Lightweight

Materials that possess the qualities of thermal capacity tend to be dense and require considerable amounts of energy to extract, move and process. The chemical reaction that turns limestone into concrete releases enormous quantities of CO₂. All of this energy is said to be “embodied” in the material that arrives on site. In contrast lightweight materials, particularly timber, are responsible for the emission of relatively low quantities of CO₂-e, or “embodied energy”(embodied CO₂- equivalent – E- CO₂-e). Some argue that the storage of carbon in the timber makes it a carbon negative building product. Others argue that since the building will be demolished the sequestration is only short term and so not relevant to climate change, or that the worlds timber resources are shrinking so that while timber is, in theory, renewable it is currently not being renewed (Hammond and Jones, 2008).

The principles of the use of thermal capacity to improve the energy efficiency of a space are well established. When the embodied energy, or embodied CO₂-equivalent of the fabric of the building is also considered a balance has to be found between the initial investment of CO₂-equivalent into the fabric of the building and the energy saved over the lifetime of the building. How or where this balance is struck depends on the anticipated lifetime of the building, and the local climate.

In a study of an English semi-detached house Hacker et al found that ,over 100 years in a scenario assuming a “medium-high” climate change scenario, a high capacity house would have lower lifetime E- CO₂-e emissions than a lightweight house (Hacker et al., 2008). The study suggests that after about 50 years the stabilising influence of thermal capacity on temperature saves enough energy to offset the initial high cost in terms of embodied CO₂.

Another UK study by Kendrick et al has suggested that while thermal capacity can be very useful lightweight construction can be optimised to achieve similar levels of thermal comfort (Kendrick et al., 2012). Kendrick et al suggest that the design approach needs to be more nuanced than simply thermal capacity or lightweight, pointing out that thermal capacity can help keep a room cool during the day but then make it harder to cool down in the evening. They suggest that bedrooms would be better built from lightweight construction because they are used at night so it is important to be able to get them to a comfortable temperature quickly in the evening. Living areas occupied during the day would benefit from the stabilising influence of thermal capacity on ambient air temperature.

In another optimisation study in Sydney, Australia, Bambrook et al (2011)found that while some thermal capacity is useful additional thermal capacity made little difference. The suggestion that the influence of the thermal capacity on temperature wanes with quantity is supported by other research by Shaviv et al and Slee et al

(Shaviv et al., 2001, Slee et al., 2013). Both studies show that adding thermal capacity to a space reduces the diurnal temperature range in that space and that adding additional thermal capacity has less of an influence, until a point when adding further capacity makes no difference to the temperature variation of the space at all. Bambrook et al conclude that the addition of bulk insulation and increased glazing performance were the dominant efficiency measures

3.0 Research Questions

This paper seeks to understand how, in a direct gain system commonly advocated for energy efficient housing in Australia:

- How the impact of the quantity of thermal capacity in a space effects the predicted annual energy consumption?
- How the location of the thermal capacity in the space effects the predicted annual energy consumption?
- How the size of the north (equator) facing window effects the predicted annual energy consumption?
- How the introduction of thermal capacity influences the lifetime CO₂-equivalent emissions of a space?

In the three most populous cities in Australia: Melbourne, Greater Sydney and Brisbane. In Sydney the climate changes as the distance from the coast increases. We have chosen to use a climate file from Penrith, in Sydney's west because the majority of the city's population lives in the west and that is where the majority of new houses are being built. For Melbourne and Brisbane we have chosen to use the climate files for the city centres.

4.0 Method

4.1 The test cell building

We designed a single room house to replicate a reasonable living area in a house with internal dimensions of 8m (E-W), 4m (N-S) and 3m high. There is a south facing window 2m long and 0.6m high and a full height north (equator) facing window that has a variable width. The roof overhangs so that the north facing window is fully shaded at noon on the spring and autumn equinoxes. The base case model is a lightweight structure. Thermal capacity is added to the inside of the building envelope in the form of concrete slabs (floor and ceiling) and bricks (walls) (Fig. 7) to create eight different configurations (table 2):

4.2 Simulation software

We used BERS Pro to simulate the energy use of the space and AccuRate to calculate the embodied energy in each construction variation. BERS Pro and AccuRate are both accredited under the Australian National Home Energy Rating Scheme (NatHERS) that is used for statutory approvals for new houses in Australia. The simulation model was not validated for this particular experiment. The software has been validated using the Bestest methodology as part of the accreditation process (BERS_Pro_Plus, 2010, Delsante, 2004). We used the default settings for the programs as stipulated by the Australian Building Codes Board. The settings simulate the operation of the building in a mixed mode system automatically opening and closing windows, and calculates heating and cooling loads to maintain an internal

temperature between the set points defined below. The heating and cooling loads are based on the use of a split cycle air conditioning unit. A standard occupancy pattern and auxiliary heat loads for a family are defined (NatHERS, 2012). In this study, a one room house is considered, categorised in the software as kitchen/ living space. Thermal comfort is maintained from 0700 to 2400. The heating setpoint is 20.0°C and the cooling thermostat setpoint is set at January’s neutral temperature, which generally has the highest mean monthly temperature in Australia (table 3).

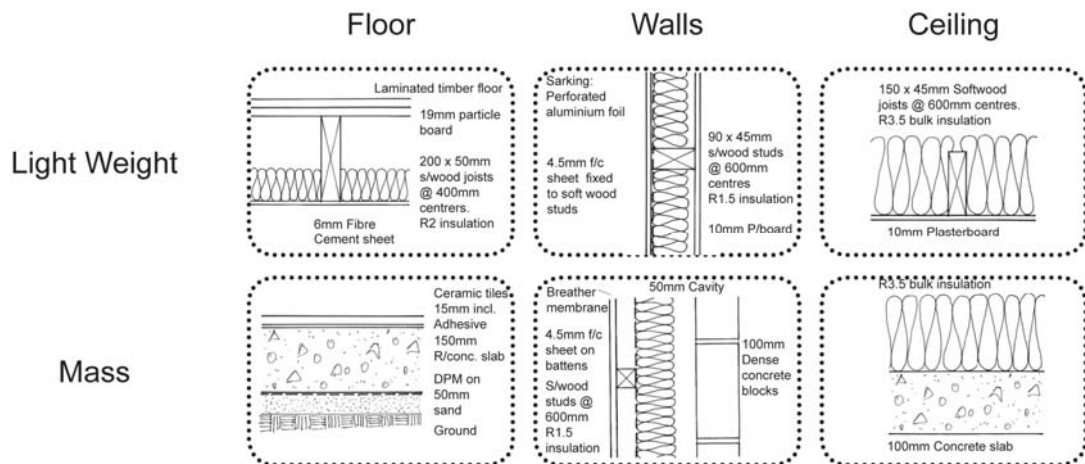

Figure 7. Floor, wall and ceiling construction variations

Table 2. Construction typologies (LW – lightweight, M – Thermal Capacity added)

Typology:	A	B	C	D	E	F	G	H
Floor:	LW	M	LW	LW	M	M	LW	M
Wall:	LW	LW	LW	M	LW	M	M	M
Ceiling:	LW	LW	M	LW	M	LW	M	M

Table 3. Heating and cooling set points for simulation

	Melbourne	Penrith	Brisbane
Heating set point	20°C	20°C	20°C
Cooling set point	24.0°C	24.5°C	25.5°C

The software uses the same weather files that are used for EnergyPlus simulation software. The weather files are embedded and locked within the software, and users are not allowed to add a new weather file or alter existing files.

We used the predicted annual heating and cooling loads expressed as MJ/m² of floor area to assess the energy and comfort performance of each scenario.

5.0 Results

The results for the 64 simulations carried out for each climate are illustrated by the graphs in figures 8 - 13 below with an accompanying description. Thermal capacity is described in KJ/k.m^3 where m^3 is the volume of the space, i.e. thermal capacity per cubic meter of space. Construction typologies are referred to by their letter (A – H) and, where the window size is important, by the letter and the window size, e.g. A/25% (typology/window size).

5.1 Melbourne

5.1.1 The impact of the quantity of thermal capacity

In Melbourne annual energy consumption falls when some thermal capacity is added to the lightweight structure (Graph 8.i - B or C compared to A). As additional capacity is added the annual cooling load is reduced further but the annual heating load is increased (graph 8.iii) resulting in no net reduction in annual energy use and, in certain scenarios, an increase in annual energy use.

5.1.2 The impact of the location of thermal capacity

The location of the thermal capacity has a particularly pronounced effect on the annual heating load in the medium-heavyweight configurations F and G (graph 8.i). When the thermal capacity is moved from the floor to the ceiling annual energy use falls by up to 39% (5% window area). This reduction is the result of reduced annual heating (graph 8.iii) and is surprising because classic direct gain systems rely on thermal capacity in the floor to assist in heating a space.

The distribution of the thermal capacity has a smaller influence on the annual cooling load in the medium weight structures B, C and D: When thermal capacity is moved from the floor or ceiling to the walls and the quantity increased there is no improvement in performance (graph 8.iii).

5.1.3 The impact of the size of the window

For all construction typologies increasing window area results in an increase in annual energy consumption (graph 8.ii). The relative increases in the annual heating and cooling loads are similar except for typologies E, F and G that have high thermal capacity and high annual heating loads with small or large windows.

5.1.4 Lifecycle CO₂ emissions

In Melbourne the configuration with the lowest annual energy consumption, Typology G/5% also has the lowest predicted lifetime CO₂-e emissions after 25, 50 and 100 years (Figure 9). The embodied CO₂-e of this medium-heavyweight structure accounts for 34% of the 25,725kg net CO₂-e emissions after 25 years. With the same window area typologies B, C and D have considerably less embodied CO₂-e and, after 25 years have predicted net CO₂-e emissions less than 1000kg higher. After 50 years these four configurations are still the most efficient separated by 4,500kg CO₂-e net emissions and the 3 less efficient configurations separated by only 1,637kg CO₂-e.

Construction typologies:

A	B	C	D	E	F	G	H
Embodied CO ₂ -e : 4,828 kg	Embodied CO ₂ -e : 6,245 kg	Embodied CO ₂ -e : 6,525 kg	Embodied CO ₂ -e : 8,358 kg	Embodied CO ₂ -e : 8,995 kg	Embodied CO ₂ -e : 8,995 kg	Embodied CO ₂ -e : 9,275 kg	Embodied CO ₂ -e : 10,692 kg
Sequestered CO ₂ -e : 3,874 kg	Sequestered CO ₂ -e : 2,745 kg	Sequestered CO ₂ -e : 3,874 kg	Sequestered CO ₂ -e : 3,124 kg	Sequestered CO ₂ -e : 2,745 kg	Sequestered CO ₂ -e : 2,745 kg	Sequestered CO ₂ -e : 3,874 kg	Sequestered CO ₂ -e : 2,745 kg

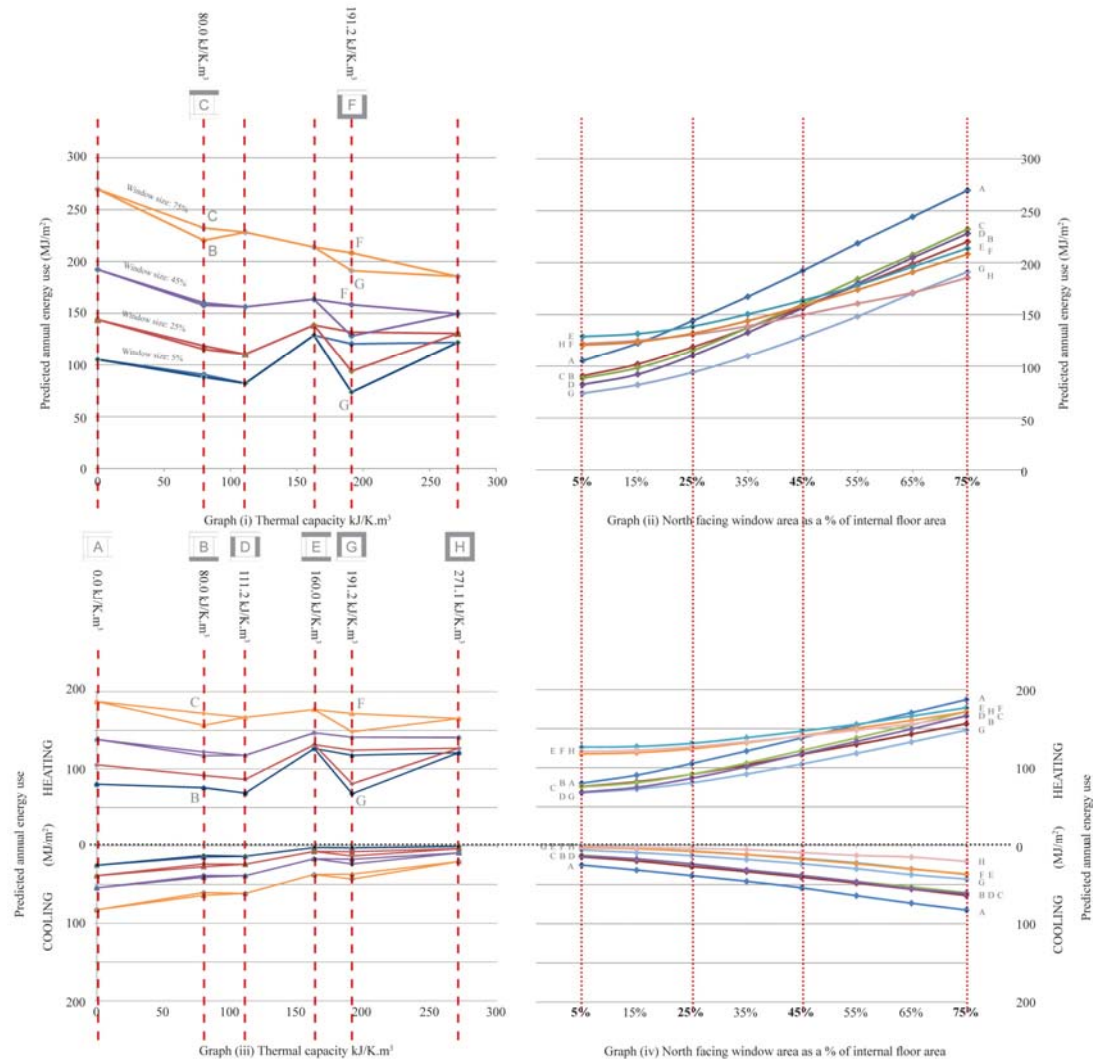

Figure 8.

Graphs 8.i, 8.ii, 8.iii and 8.iv – Melbourne - Predicted annual energy loads plotted against thermal capacity and window area

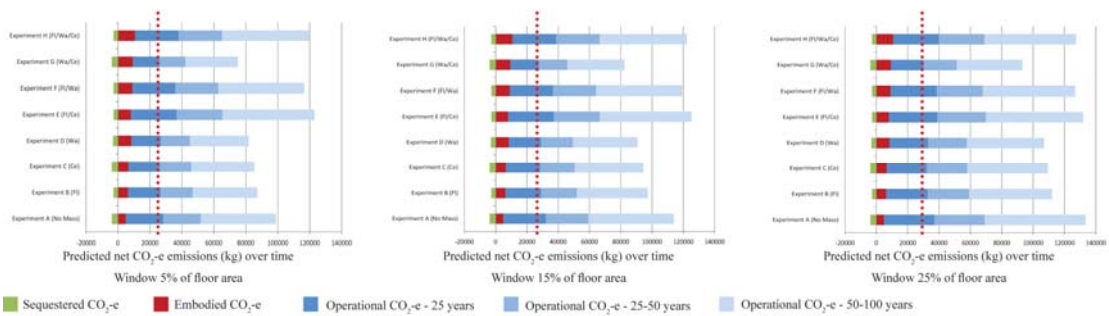

Figure 9. Melbourne - predicted net CO₂-e emissions over 25, 50 and 100 years

5.2 Penrith

5.2.1 The impact of the quantity of thermal capacity

In Penrith annual energy consumption falls as the quantity of thermal capacity in the space is increased (graph 10.i). This fall is primarily due to a reduction in annual cooling energy loads (graph 10.iii). The annual heating load falls when capacity is added to the lightweight typology (Compare typ. A with typ. B & C). When additional capacity is added (typ D-H) and the distribution altered the thermal response of the space becomes more complex (graph 10.iii). For the configurations with the smallest window (5%) increasing thermal capacity in the space above 111 kJ.K.m³ increases energy consumption (graph 10.i).

With smaller windows the influence on annual cooling loads of adding thermal capacity to the space diminishes with quantity. Increasing the thermal capacity above 160 kJ/k.m³ (of space) has a minimal influence on the cooling load, following a similar pattern to that observed by Shaviv et al and Slee et al (Shaviv et al., 2001, Slee et al., 2013).

The response of the annual cooling load to increasing quantities of thermal capacity is “stepped” rather than approximating to a curve (graph 10.iii). Increasing the quantity of thermal capacity by 39% (Typology B/C to D) results in almost no change in thermal performance. A further 44% increase and redistribution (D – E) results in improvements in performance with more significant improvements occurring in configurations with larger windows. The “stepped” response is also clear on the graph plotting cooling load against window size (graph 10.iv) where different construction typologies are separated into four groups (table 4):

Table 4. Separation of construction typologies into 4 groups

Lightweight:	Typology A
Medium weight:	Typologies B, C and D
Medium –heavyweight:	Typologies G,E and F
Heavyweight:	Typology H

5.2.2 The impact of the location of thermal capacity

This “stepped response” of the cooling load illustrated in graph 10.iii suggests that the location of the thermal capacity on the floor (B), or on the ceiling (C), or on the walls (D) makes little difference to the cooling energy load. When there is thermal capacity in the walls and then capacity is moved from the ceiling to the floor (typologies F and G) the cooling load is hardly effected however there is a significant change in the heating loads particularly with small and medium sized windows (<45%). A similar effect was observed in Melbourne.

5.2.3 The impact of the size of the window

In Penrith there is an optimal balance between the size of the window and the quantity of thermal capacity in the space (graph 10.ii). For the lightweight and medium weight structures (A, B, C and D) increasing window size reduces efficiency overall. For all typologies increasing window size increases the annual cooling load (graph 10.iv). For structures with some thermal capacity (B-H) there is an optimal window size where the annual heating load is minimised, this must be balanced with the increasing annual cooling load meaning that it is only the medium heavy and heavyweight

Construction typologies:

A	B	C	D	E	F	G	H
Embodied CO ₂ -e : 4,828 kg	Embodied CO ₂ -e : 6,245 kg	Embodied CO ₂ -e : 6,525 kg	Embodied CO ₂ -e : 8,358 kg	Embodied CO ₂ -e : 8,995 kg	Embodied CO ₂ -e : 8,995 kg	Embodied CO ₂ -e : 9,275 kg	Embodied CO ₂ -e : 10,692 kg
Sequestered CO ₂ -e : 3,874 kg	Sequestered CO ₂ -e : 2,745 kg	Sequestered CO ₂ -e : 3,874 kg	Sequestered CO ₂ -e : 3,124 kg	Sequestered CO ₂ -e : 2,745 kg	Sequestered CO ₂ -e : 2,745 kg	Sequestered CO ₂ -e : 3,874 kg	Sequestered CO ₂ -e : 2,745 kg

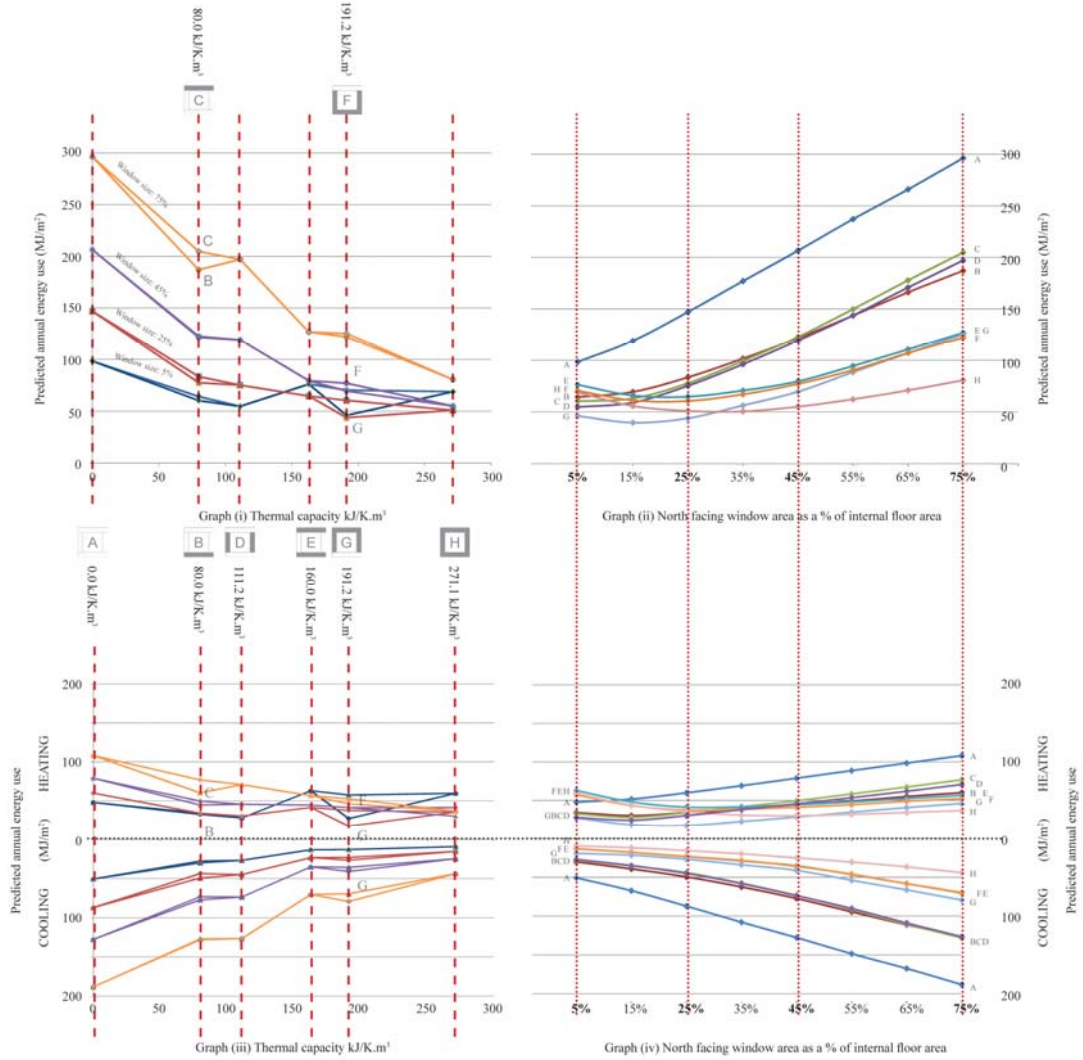

Figure 10.

Graphs 10.i, 10.ii, 10.iii and 10.iv – Penrith (Sydney) - Predicted annual energy loads plotted against thermal capacity and window area

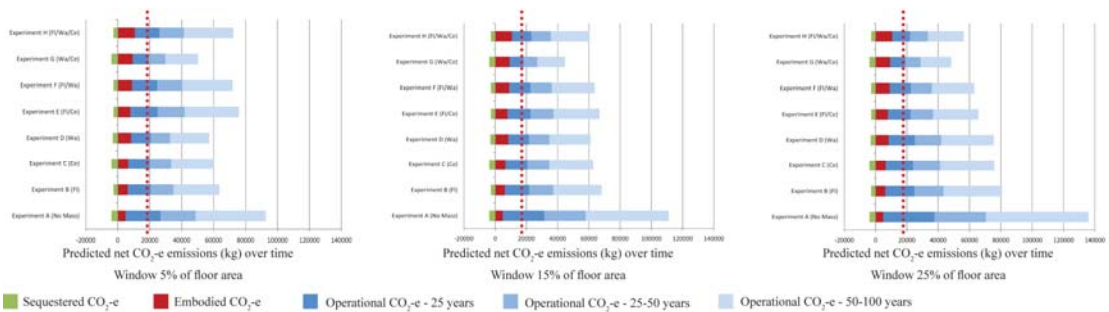

Figure 11. Penrith - predicted net CO₂-e emissions over 25, 50 and 100 years

typologies E, F, G and H that find an optimum balance between thermal capacity and window size. The balance point depends on the quantity and configuration of the thermal capacity.

As with Melbourne the classic explanation of a direct gain system appears to be defied: The most efficient construction typology is G with capacity in the walls and the ceiling and a window sized at 15% of the floor area. The high capacity typology (H) is the next most efficient when the window is sized at 35% of floor area. Construction typologies E (capacity on the floor and ceiling) and F (capacity on the floor and walls) are comparable with each other and most efficient when the window is 25% of the floor area.

5.2.4 Lifecycle CO₂ emissions

After 25 years the configuration with the lowest predicted net CO₂-e emissions is G/15%, also the configuration with the lowest annual operational emissions (Figure 11). This is a medium-heavyweight construction with walls and ceiling in thermal capacity (9275 kg CO₂-e) accounting for 51% of the net emissions after 25 years. The structure that achieves a net CO₂-e emission level close to typology G is typology C with annual operational emissions 59% higher than typology G but 25 year net emissions only 14% higher because of the structure's lower embodied energy.

5.3 Brisbane

5.3.1 The impact of the quantity of thermal capacity

In Brisbane annual energy consumption falls with the addition of thermal capacity to the space (graph 12.i). There is a small reduction in annual heating loads when thermal capacity is added to a lightweight structure (Typ. A compared to B/C) but overall the annual heating load is minimal and the efficiency of the space is dominated by reductions in the cooling load. The "stepped" response to additional thermal capacity observed in Penrith is also seen in Brisbane and the typologies form into the same four groups. There also appears to be little benefit to adding additional thermal capacity to the space beyond 160 kJ/k.m³(typ. E).

5.3.2 The impact of the location of thermal capacity

The "stepped" response of the cooling loads to the addition and distribution of the thermal capacity observed in the climates of Melbourne and Penrith is observed in Brisbane.

5.3.3 The impact of the size of the window

Increasing the size of the window reduces the energy efficiency of all the typologies exponentially (graph 12.ii).

5.3.4 Lifecycle CO₂ emissions

In Brisbane, where predicted annual energy consumption (in this simulation) is relatively low, the embodied energy of the structure forms a larger part of the net CO₂-e emissions and means that for the relatively efficient structure (H/5%), at 185kg CO₂-e/year, embodied energy is responsible for 70% of net emissions after 25 years making it less efficient than lighter weight typologies B, C and E (figure 13). Configuration H/5% is still marginally less efficient than configurations E/5% and F/5% after 50 years. However in all cases these net differentials are less than 2,000 kg CO₂-e overall.

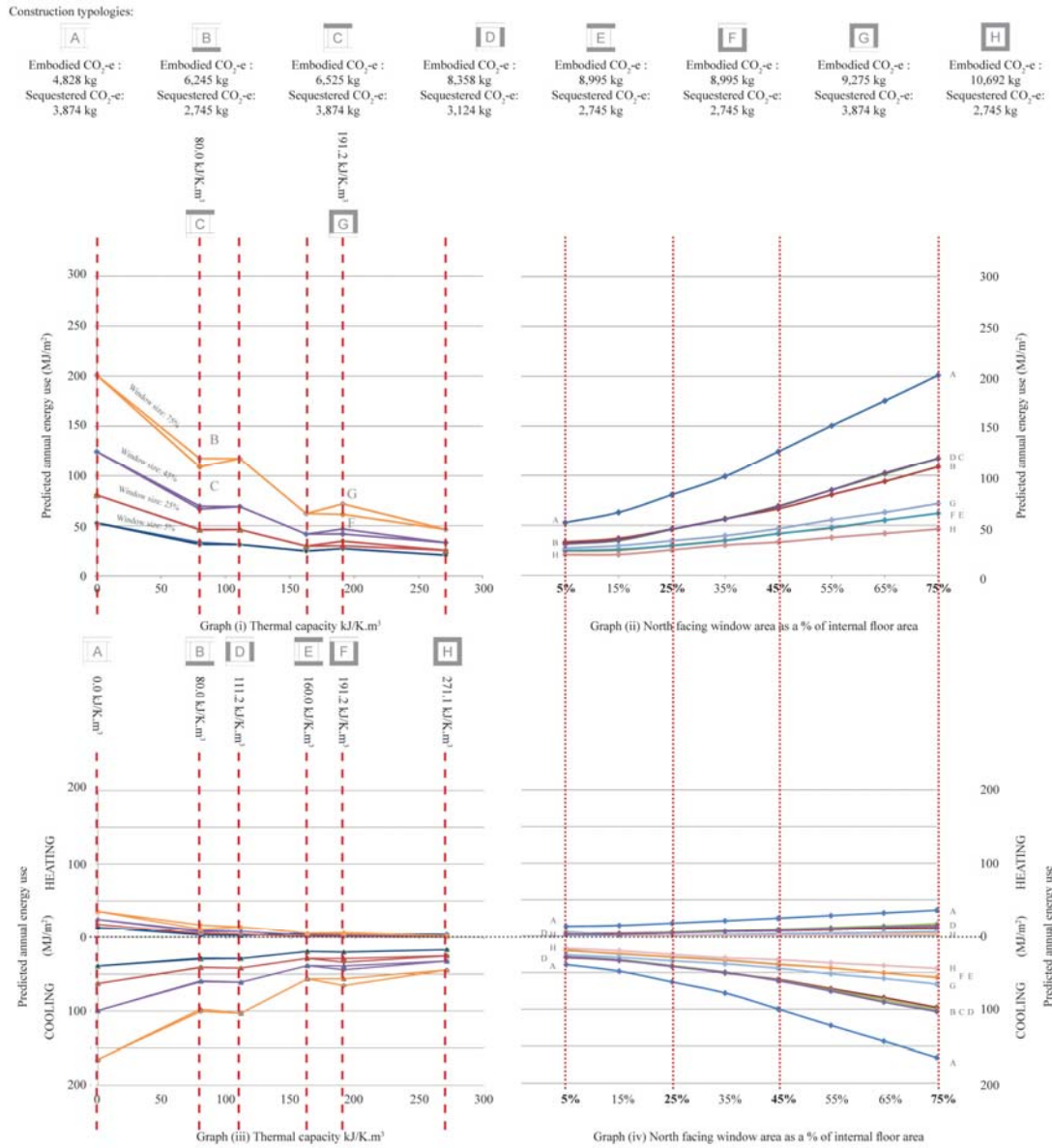
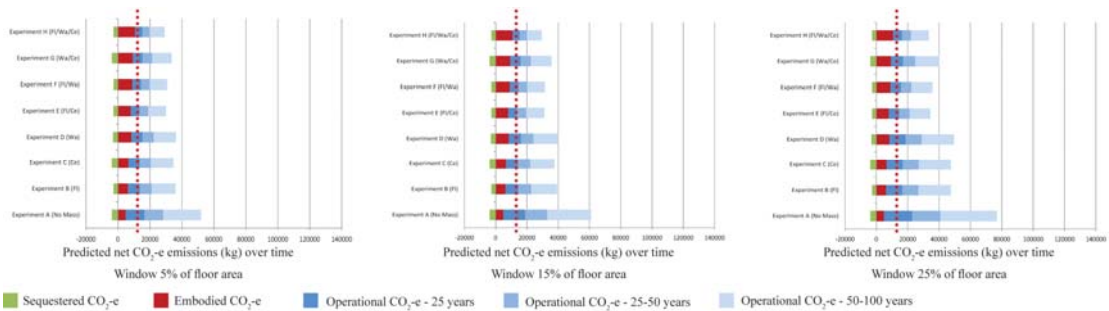

Figure 12.

Graphs 12.i, 12.ii, 12.iii and 12.iv – Brisbane - Predicted annual energy loads plotted against thermal capacity and window area



5.4 Summary

The results from the three climates have the following in common:

- The influence of thermal capacity on the energy performance of the space becomes more pronounced as the size of the window is increased. The largest improvements in energy efficiency associated with thermal capacity occur when the window area is large (75% of floor area).
- In all climates increasing the quantity of thermal capacity reduces the annual cooling load.
- Energy consumption increases with increasing window area. In Penrith there are four construction scenarios where there is an optimum window area that will minimise the annual energy consumption for a particular construction (construction variations E, F, G and H). The balance point differs between construction variations.
- The location of the thermal capacity influences the thermal performance of the space. How this manifests itself differs from climate to climate.

6.0 Discussion

It is clear that the thermal response of the simulated building to variations in the quantity and distribution of thermal capacity, and changing the size of the north (equator) facing window, is different in each of the three climates. Therefore the configuration that minimises net CO₂-e emissions over the lifetime of the building will need to be different in each climate.

In all three climates increasing the size of the window and the corresponding direct solar gain caused an increase in annual cooling loads, the increased window size also caused an increase in heating loads in Brisbane and Melbourne. Only in Penrith was an optimum window size observed.

In the contrasting climates of Melbourne and Brisbane, were it not for the limitations of the experiment, one might conclude that small windows are more efficient. However, since we did not vary the level of solar shading it might also be suggested that (i) better solar control is needed and/or that (ii) a direct gain strategy is not appropriate for these climates:

In Melbourne it appears to be the distribution rather than the quantity of thermal capacity or the size of the window that improves annual energy performance. The cold and cloudy winter climate is not favourable for significant and regular direct thermal gains from the sun in winter. Graph 8.iii shows us that the space does benefit from the presence of thermal capacity in summer. The warm and occasionally hot summer with outside diurnal temperature range greater than 10 °C is favourable for utilising thermal capacity for night cooling.

In Brisbane the simulation suggests that there is little need for winter warmth and so the principle purpose of a direct gain system, storing warmth from the sun to reduce heating requirement on cool evenings, is redundant in this climate. The addition of thermal capacity reduces the annual cooling load in Brisbane (graph 12.iii) but, with the configuration we simulated, increasing the size of the window increases the cooling loads. It is therefore likely that, like in Melbourne, the benefit of thermal capacity is in storing “coolth” rather than warmth, utilising the modest diurnal

temperature range. In Penrith the influence of thermal capacity on annual cooling loads is also important.

In Penrith the principles of a direct gain system do appear to apply. There is clearly an optimal balance between the quantity of thermal capacity and the size of the window. It is surprising that the most efficient configuration does not have a ground slab. This may be because in our simulations the ground slab is cast directly on the ground (ground coupled) as is the practice in Australia. This may mean that cool and cold winter nights in both Melbourne and Penrith cause thermal losses from the ground slab offsetting passive solar gains made during the day.

When the embodied CO₂-e emissions of the structure are also considered the benefits of high levels of thermal capacity are less obvious. In the simulations structures with less thermal capacity were very nearly as efficient and occasionally more efficient than higher capacity typologies over 25, 50 and even 100 year time frames.. The operational CO₂-e emissions have been calculated using current emissions figures (BREE et al., 2013) for Australia where 96% of energy comes from carbon based sources. If renewable energy sources are utilised more effectively in Australia, then the balance between operational energy and embodied energy will change, possibly significantly. This will make lower embodied energy structures more efficient over longer time frames.

7.0 Conclusion

The study simulated a single space building in the three Australian climates of Melbourne, Penrith (Sydney) and Brisbane. The quantity and location of the thermal capacity and the size of the north (equator) facing window were varied. The calculated annual heating and cooling energy loads were used to assess the impact of the variations. The predicted annual energy consumption was converted into kg of CO₂-e and combined with the calculated embodied CO₂-e of each configuration to estimate the lifetime CO₂-e emissions of the various scenarios over 25, 50 and 100 years.

It is clear that thermal capacity can improve the thermal efficiency of the simulated structure in all three climates, primarily through its influence on annual cooling loads. It seems likely that a direct gain system is only appropriate for the climate in Penrith and that thermal capacity should be used in Melbourne and Brisbane to mitigate summer overheating.

The location of thermal capacity influences the annual heating load. This may be due to heat lost through the ground coupled concrete slab in winter.

Increasing the size of the window increases the annual cooling load in all three climates and the annual energy consumption in Brisbane and Melbourne. Increasing solar shading (reducing direct gain) may mitigate this effect. In Penrith an optimum window size can be found for a particular quantity of thermal capacity.

When lifetime c CO₂-e emissions are calculated a number of possible optimal configurations emerge from simulations with no single configuration in any particular climate emerging as the optimal solution. Medium weight and medium-heavyweight typologies offer comparable solutions. The results suggest that it would be useful to explore further modifications to the fabric and form of the building in each climate

including reducing or eliminating direct solar gain and insulating the building from the ground.

8.0 Acknowledgements

This research was funded by Forest and Wood Products Australia with additional assistance from CSR as part of a project investigating the use of thermal capacity in timber framed construction across Australia. The project was carried out by the University of Sydney, Australia.

9.0 References

- ASHRAE 2010. ANSI/ASHRAE Standard 55-2010: Thermal Environmental Conditions for Human Occupancy. Atlanta: American Society of heating, Refrigerating and Air-conditioning Engineers.
- ASHRAE_2010_ADDENDUM_D 2012. Addendum d to ANSI/ASHRAE Standard 55-2010: Thermal Environmental Conditions for Human Occupancy. Atlanta: American Society of heating, Refrigerating and Air-conditioning Engineers.
- AUSTRALIAN_BUREAU_OF_STATISTICS. 2011. *4602.0.55.001 - Environmental issues: energy Use and Conservation, March 2011* [Online]. Available: http://www.abs.gov.au/AUSSTATS/abs@.nsf/Latestproducts/4602.0.55.001Main_2011?opendocument&tabname=Summary&prodno=4602.0.55.001&issue=Mar_2011&num=&view= [Accessed 1/05/2013].
- BAGGS, D. & MORTENSEN, N. 2006. Thermal Mass in Building Design. *Environmental Design Guide*. Royal Institute of Australian Architects and Australian Council of Building Design Professions Ltd.
- BAMBROOK, S. M., SPROUL, A. B. & JACOB, D. 2011. Design optimisation for a low energy home in Sydney. *Energy and Buildings*, 43, 1702-1711.
- BERS_PRO_PLUS 2010. BERS Pro Plus Energy and Carbon Emission Additions to BERS Pro. In: WILLRATH, H. (ed.). *Solar Logic*.
- BREE, NHU CHE, ALEX FENG, CAITLIN MCCLUSKEY, PAM PHAM, WILLCOCK, T. & STANWIX, G. 2013. 2013 Australian Energy Update. Canberra: Australian Bureau of Resources and Energy Economics <http://www.bree.gov.au>.
- CHEN, D. S., M; SEO, S; CHAN, W. Y; ZHOU, M; MEDDINGS, S 2010. Development of an embodied CO2 emissions module for Accurate. Forest & Wood Products Australia (FWPA).
- DE DEAR, R. Thermal Comfort in Natural Ventilation: a neurophysiological hypothesis. 2010 WINDSOR CONFERENCE: ADAPTING TO CHANGE: NEW THINKING ON COMFORT, 2010.
- DE DEAR, R. & BRAGER, G. S. 1998. Developing an Adaptive Model of Thermal Comfort and Preference. *ASHRAE Transactions*, 104 (1), 145 - 167.
- DELSANTE, A. 2004. A validation of the "AccuRate" simulation engine using Best Test. The Australian Green House Office.
- GIVONI, B. 1998. Effectiveness of mass and night ventilation in lowering the indoor daytime temperatures. Part I: 1993 experimental periods. *Energy and Buildings*, 28, 25-32.

- GREENLAND, J. & SZOKOLAY, S. V. 1985. *Passive solar design in Australia / Jack Greenland and Steve Szokolay*, Red Hill, A.C.T. :, RAI Education Division.
- GREGORY, K., MOGHTADERI, B., SUGO, H. & PAGE, A. 2008. Effect of thermal mass on the thermal performance of various Australian residential constructions systems. *Energy and Buildings*, 40, 459-465.
- HACKER, J. N., DE SAULLES, T. P., MINSON, A. J. & HOLMES, M. J. 2008. Embodied and operational carbon dioxide emissions from housing: A case study on the effects of thermal mass and climate change. *Energy and Buildings*, 40, 375-384.
- HAMMOND, G. P. & JONES, C. I. 2008. Embodied energy and carbon in construction materials. *Proceedings of Institution of Civil Engineers: Energy*, 161, 87-98.
- HOLLO, N. 1986. *Warm house cool house : inspirational designs for low-energy housing*, Marrickville, N.S.W. :, Choice Books.
- KENDRICK, C., OGDEN, R., WANG, X. & BAICHE, B. 2012. Thermal mass in new build UK housing: A comparison of structural systems in a future weather scenario. *Energy and Buildings*, 48, 40-49.
- KIVVA, T., HUYNH, B. P., GASTON, M. & MUNN, D. 2009. A numerical study of ventilation flow through a 3-dimensional room with a fan. 0, 10.
- LA ROCHE, P. & MILNE, M. 2004. Effects of window size and thermal mass on building comfort using an intelligent ventilation controller. *Solar Energy*, 77, 421-434.
- NATHERS 2012. NATIONWIDE HOUSE ENERGY RATING SCHEME (NatHERS) – SOFTWARE ACCREDITATION PROTOCOL.
- OPPENHEIM, D. (ed.) 2007. *Bainsdale, Victoria*, Canberra: Australian Greenhouse Office.
- REARDON, C. 2001. *Your home : design for lifestyle and the future. Technical manual / principal author : Chris Reardon*, Canberra :, Australian Greenhouse Office.
- SHAVIV, E., YEZIORO, A. & CAPELUTO, I. G. 2001. Thermal mass and night ventilation as passive cooling design strategy. *Renewable Energy*, 24, 445-452.
- SLEE, B. & HYDE, R. 2011. Evaluating ‘Rules of Thumb’ for integrating fabric storage (thermal mass) into lightweight construction in Australia. *ASA (ANZAScA) 2011*. University of Sydney.
- SLEE, B., PARKINSON, T. & HYDE, R. 2013. Can you have too much thermal mass? In: SCHNABEL, M. A. (ed.) *Cutting Edge: 47th International Conference of the Architectural Science Association*. Hong Kong: The Architectural Science Association.
- SUGO, H. P., A. W.; MOGHTADERI, B 2004. Comparative study of the thermal performance of cavity brick veneer construction. *13th International Brick and Block Masonry Conference*. Eindhoven, Holland: University of Newcastle (2004).
- TOFTUM, J. 2004. Air movement – good or bad? *Indoor Air*, 14, 40-45.
- XIA, Y. Z., NIU, J. L., ZHAO, R. Y. & BURNETT, J. 2000. Effects of Turbulent Air on Human Thermal Sensations in a Warm Isothermal Environment. *Indoor Air*, 10, 289-296.
- ZHAO, R. 2007. Investigation of transient thermal environments. *Building and Environment*, 42, 3926-3932.

Effect of Structure and Morphology on Natural Ventilation Potentials, Comfort, and Energy Use in Tall Buildings

Juliana Felkner^{1,2} and Eleni Chatzi²

¹Chair of Structural Design, Department of Architecture, ETH Zurich, Switzerland

²Chair of Structural Mechanics, Department of Civil Engineering, ETH Zurich, Switzerland

Corresponding Author, Juliana Felkner, jfelkner@arch.ethz.ch

Abstract

In recent years, more and more tall buildings have a mixed-use or residential program. This shift from formerly mainly office use requires new evaluations and guidelines for occupant comfort. This paper examines the relationship between the structural core of the building, its floor plan, the overall shape and its potential for natural ventilation, and how these relate to human comfort, energy efficiency and structural performance. The results are qualitative recommendations for the initial design stage of a tall building in a given climate zone.

1 Introduction

Tall buildings address sustainability in terms of increasing density in cities, thereby reducing travel distances and land use. In recent years, more and more tall and super tall buildings are offering mixed-use layouts (see Fig. 1). This requires that comfort issues in tall buildings increasingly need to be considered from a residential perspective rather than only from an office perspective.

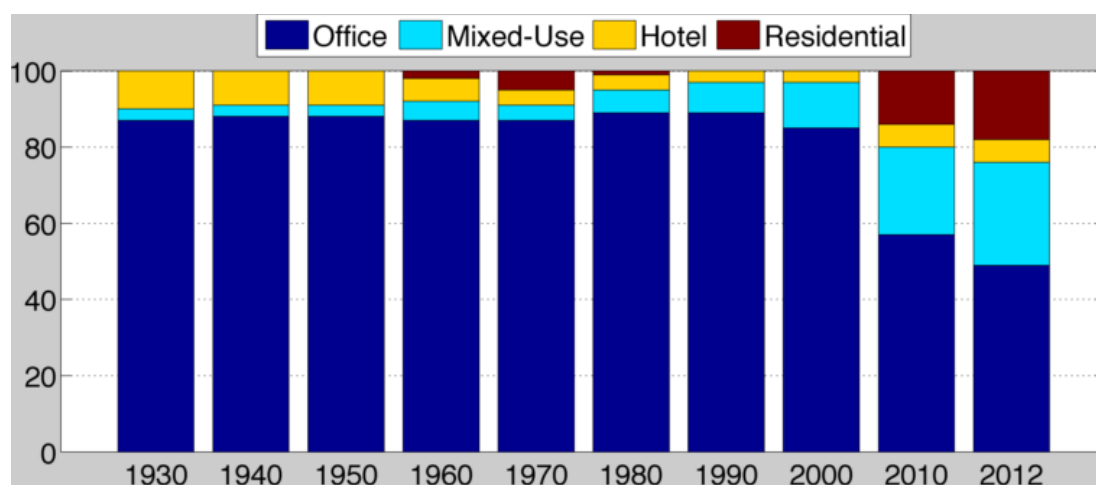

Figure 1. Different uses of tall buildings throughout history (adapted from Brass, Wood and Carper, 2013)

In particular, this research is concerned with potentials for natural ventilation. We argue that tall buildings must be designed with the possibility for natural ventilation, even if it is only

used for part of the year or for a few hours out of the day, especially in order to increase comfort for residential inhabitants and to reduce incidences of sick building syndrome. Natural ventilation increases comfort by providing a means to exchange air and a means for cooling, while also reducing energy demands. In tall buildings, natural ventilation typically takes the form of either operable windows, the use of stack effect, ventilated double façade, or a combination of these.

Further, we focus on the use of operable windows specifically, as this form of natural ventilation is considered to offer the greatest feeling of control to the occupant, especially in a residential setting. Comfort levels through operable windows are achieved through reducing indoor temperature and encouraging air movement. (Nicol and Humphreys, 2004), (Brager, Paliaga, de Dear, 2004)

When designing tall buildings, structure and form need to be considered to reduce wind loadings. Ventilation and thermal strategies are often secondarily, as the operational costs of the building come second to the investment costs of the initial construction. But in considering environmental impacts, both the embodied energy and operational energy requirements need to be considered.

Individual guidelines exist for designing tall building structures for comfort, such as core placement and building morphology for thermal performance. Guidelines also exist for aerodynamic forms. However, these objectives are not yet considered in a holistic way along with natural ventilation for tall buildings. Specifically, little research exists on the combined potential of all of these objectives for natural ventilation in the form of operable windows.

In this research, we provide an overview of design guidelines, which shape the building based on all of these considerations equally, for a given climate zone and wind direction. The results are initial design guidelines and recommendations that can serve as starting points when designing a new building for a particular location.

2 Background

In this section, research for each topic: Structure and Energy Efficiency, Aerodynamic Forms, and Natural Ventilation, in the context of tall buildings, is briefly reviewed.

2.1 Structure and Energy Efficiency

Krem analyzes the trade-offs in the design of structural systems for both structural and energy performance. (Krem 2013) He bases his work on Yeang's classification, which suggests optimal floor plans and core placements to reduce energy consumption in four climate zones (Yeang, 1999). These are shown in Figure 2. For example, in a cold climate the central core is found to be most efficient, but for a tropical one, two cores placed on the most sun-exposed sides perform better, as the cores reduce solar heat gain.

Based on structural and environmental simulations, Krem further analyzes Yeang's structural configurations (placement of core and building shape) for specific climates, both for their structure and environmental performance combined. He concludes that some of the best energy performance configurations would require significantly greater structural mass, and therefore proposes future research is needed so that these objectives can be balanced.

Therefore, for him, a first step is to consider the environmental performance of a form, and then find what structural solution could make it work.

For natural ventilation, as well, considering the environmental performance of the form is the first step. Avoiding solar heat gain complements any natural ventilation strategy, as,

according to Wood and Salib, increase in solar gain would overwhelm any comfort gains of natural ventilation. (Wood and Salib, 2012)

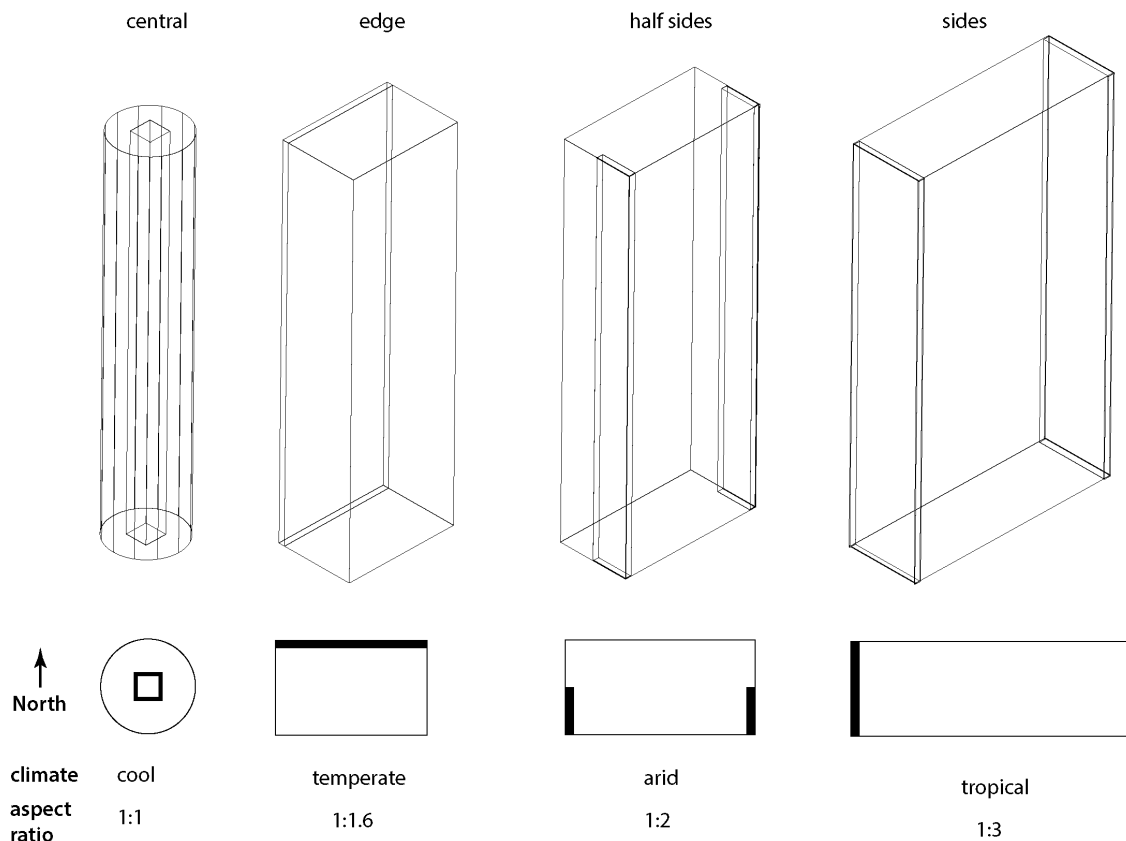

Fig. 2. Yeang's proposal for optimal core and floorplan configuration to reduce energy consumption by climate zones (adapted from Yeang, 1999).

Therefore, in this work, we also examine Yeang's proposals as a basis for further studies on the structural performance, energy performance, and comfort through ventilation combined.

2.2 Aerodynamic Forms

Since tall buildings are exposed to high wind loads, the structural design must consider horizontal loadings as the governing force. Further, the shape of the building can contribute to the reduction of wind loadings, for e.g., by presenting only a small area of the building in the direction of the prevailing wind and/or pointing or curving this face. Aerodynamic forming of tall buildings is becoming increasingly popular both due to the advances of computational fluid dynamics and the realization that the reduction of wind loading can reduce the initial cost of the construction by means of reducing the amount of structural material needed.

Recent designs including curvilinear floor plans or curved and tapering profiles have contributed to considering shape optimization for wind loading. See (Kareem, 2013) and (Felkner, 2013) for an example of the use shape optimization for the design of tall structures.

Alternatively, micro modifications can affect aerodynamic performance. For example, rounding the corners of a tall building can reduce the base moment of a square section by as much as 25% compared to a square section, as in the Tapei 101 building. (Irwin, 2006)

(Alaghmandan and Elnimeiri, 2013) recommend numerous approaches for improving the aerodynamic performance of tall buildings. For the purpose of this paper, we consider first the basic approach of orienting the building with the smallest face facing the prevailing wind, as

this approach will least alter the proportions and layout proposed by Yeang for thermal performance.

2.3 Natural Ventilation

Wood and Salib, 2012 present a compilation of case studies of natural ventilation strategies in built tall office buildings, analyzing each in depth, and grouped into three categories: single-sided ventilation, cross-ventilation, and stack ventilation. For the purposes of this paper, we differentiate between ventilation coming from single and double skinned facades, and consider only the case of a single skinned façade. According to Wood and Salib, access to operable windows provide a greater feeling of control over their environment and can, “lead to an increased tolerance for a wide range of thermal comfort standards and allow an adaptation to temperature fluctuations ...while the windows are open.” Moreover, operable windows have the potential for higher possible air exchange rates, affording occupants the benefit of both real and “psychological cooling”. Psychological cooling is the phenomenon in which higher indoor air speeds make occupants feel cooler.

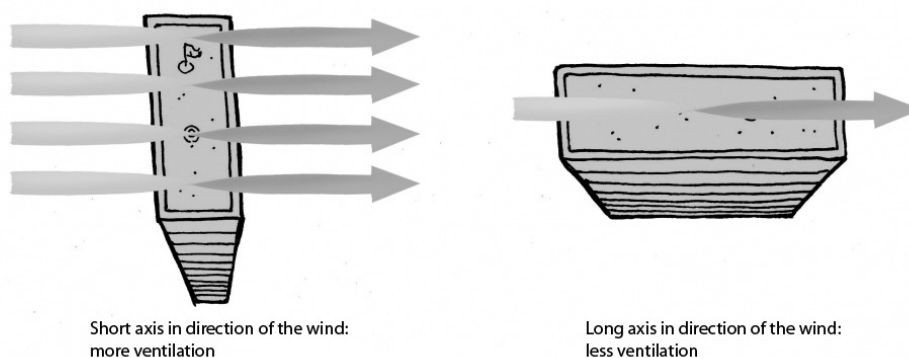

Fig. 3 Comparison of short versus long axis orientation in direction of wind in terms of ventilation (adapted from Autodesk Sustainability Workshop)

For this paper, the strategies for natural ventilation can be roughly grouped into four categories: stack effect, double skinned facades, operable windows, and the use of wing walls (Mak et al, 2007).

We are considering as the main priority the operable window effect for further analysis, because it is considered to be the one parameter likely to offer the greatest perceived comfort and control by the resident in a residential context. In terms of building form and orientation to facilitate the use of operable windows, the shorter axis of the building should be aligned with the prevailing wind direction (see Fig. 3)

Considerations for naturally ventilating tall buildings with operable windows

A distinction must be made what is comfortable for a residential versus office space in a tall building. While a residential space could better tolerate fluctuations in temperature and air exchange, office spaces are prone to having papers disturbed or becoming too damp from humidity. In a mixed-use building, a hybrid cooling and ventilation system would ensure that office comfort levels remain constant (e.g., through double skinned controlled systems, or

smaller window openings), whereas residential portions of the building could allow greater control through larger windows.

2.4 Approach

In the next section, we qualitatively analyze the combination of the three strategies, structural configuration to reduce heat gain, aerodynamic forms and natural ventilation, as a first step to creating a guide to help architects create a synthesized building shape that best creates a potential for natural ventilation, while still reducing heat gain (operational energy) and structural mass (grey/embodied energy).

The analysis begins with four forms that have already been proven to be optimal for energy consumption in the four respective climate zones. From a structural point of view, some of these forms would be problematic in particular wind directions, according to Krem. (Krem, 2013) Others would also be inferior for ventilation via operable windows in particular wind directions. Therefore, supplementary structure and possible modifications to the designs are a given. The four options are therefore evaluated in terms of their structural performance and ventilation potential in all wind directions

3. Results

In Figure 4, the four forms presented by Krem for each climate zone are evaluated in terms of their potential for natural ventilation via operable windows in conjunction with their aerodynamic performance. (Stack effect and double façade ventilation are already considered to be applicable to all four cases, depending on the layout, and are therefore not included in the analysis.)

However, when following the recommendations for natural ventilation via operable windows, one must take more care to align the shortest axis of the building (the widest face) in the direction of the prevailing winds, see Section 2.3.

Contrarily, for aerodynamics, the long axis of the building should be in the direction of the wind, meaning the building should present its shortest face (or corner) to the wind, see Section 2.2. (While a truly aerodynamic form would be curved, the following figure, Figure 4, is representative of proportions only.)

Figure 4, shows the wind direction, climate, and building form. Each combination is evaluated with the aforementioned guidelines in terms of wind loading reduction (aerodynamics) and comfort (operable windows).

As can be seen, in a cold climate, the center core with a symmetric building shape is most optimal for all wind cases.

The group in blue, which endure winds from the east and west, offers decent aerodynamic performance, as their shortest sides are in the direction of the prevailing wind, and only fair natural ventilation potential via operable windows, as their sides facing the wind do not offer as much area. In order to improve the operable window potential, wing walls could be introduced to the north and south.

For the group in orange, all experiencing northerly and southerly winds, structural performance is problematic, while the feasibility for natural ventilation through windows is quite strong. Recommendations in this group would be to investigate aerodynamic performance strategies that do not alter the aspect ratio dramatically nor introduce excessive material usage. One possibility would be introducing micro-modifications, such as rounded

corners. A macro-modification could be curving the entire face enduring the strongest wind loading, and tapering the form along the height.

energy efficient core placement and floorplan for each climate region

prevalent wind direction	wind related design parameters	cool	temperate	arid	tropical
N-S ↓	aerodynamics operable windows	✓ ✓	✗ ✗	✗ ✓	✗ ✓
S-N ↑	aerodynamics operable windows	✓ ✓	✗ ✓	✗ ✓	✗ ✓
E-W ←	aerodynamics operable windows	✓ ✓	✓ fair	✓ fair	✓ ✗
W-E →	aerodynamics operable windows	✓ ✓	✓ fair	✓ fair	✓ ✗

Figure 4. Qualitative assessment of optimal structural configurations for four climates with respect to their aerodynamic performance as well as suitability for operable windows in different wind directions.

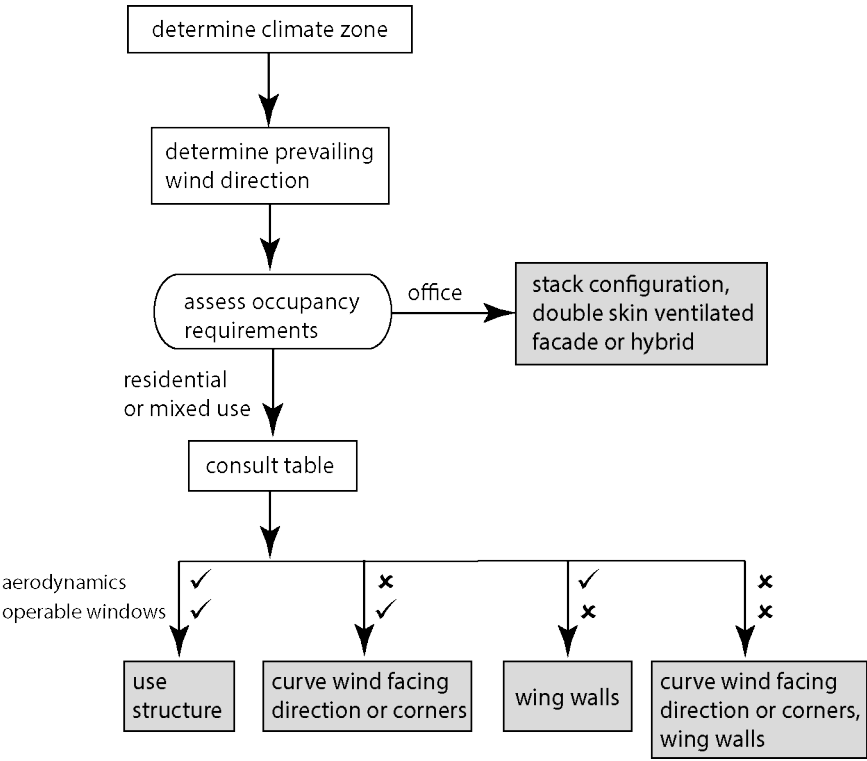

Figure 5. Flow chart to generate initial configuration of core and floor plans

The group in yellow shows decent aerodynamic profiles, but poor natural ventilation potentials via operable windows, as the cores are placed on the faces in the direction of the wind. A solution for this group would be the use of wing walls on the north and south facades.

The apparent worst performer of all is marked in red, with both poor aerodynamic and comfort (operable windows) performance. However, in terms of the aerodynamics, this could be remedied in the vertical through tapering, and horizontally through rounding the northern face. Micro-modifications such as curved corners could also help. In terms of comfort, the ability to open windows could be enhanced through wing walls on the east and west facades.

Figure 5 gives a flowchart how to generate initial design ideas based on the results in Figure 4. As can be seen, purely office spaces will have different criteria and potentials for other forms of natural ventilation. Mixed-use and residential building designers, however, can benefit from referring to the operable window feasibility table.

As noted by Krem, all plans that are asymmetric in any direction of the wind would possibly experience torsion without heavy material compensation. The compensating structural stiffness through extra material needed would possibly negate the savings in operational energy by increasing embodied energy in the structure, though he notes a full life-cycle assessment would need to be performed in order to quantify the difference. However, curving the plans in the direction of the wind would reduce this impact. Therefore, the ideal way to use the results from Figure 4 would be to imagine that all forms presented could be enhanced by curving.

For example, take the case of a mixed-use tall building planned for a site in England that has a prevailing wind generally coming from the south or southwest to the north, according to the wind rose. As England is temperate, the user would look at the temperate column in order to see the ideal morphology for energy performance. Looking at the cell in the temperate column and S-N row, one sees that Yeang's suggested form for energy performance is also an ideal form for natural ventilation, but not an ideal form for aerodynamic performance. Therefore, the user would see that more time and attention would need to be dedicated to making this form more aerodynamic or structurally efficient, without drastically changing its overall layout. A curved face and/or optimized structural system falling within the general boundaries would be possible directions to explore in addressing this trade-off.

4 Discussion

The analysis presented in this paper serves as a guideline and should not be considered prescriptive nor prohibitive of any arrangement. Architectural and or site constraints or justifications, such as important views or neighboring buildings, could all have major influences on the arrangement of the core and shaping of the floor plans. This is certainly the case, for example, with the Leadenhall building, whose location in London required specific views, and relied on other means of natural ventilation, such as a double skin façade (Young, Annereau, Butler, Smith, 2013), all while being ideally oriented for thermal comfort based on solar paths. Moreover, certain climates, such as tropical and arid, would most likely also need to employ a hybrid cooling system, allowing only residential portions or circulation areas to be ventilated via operable windows. Reference to ASHRAE psychrometric charts can further inform comfort levels for different climates, such as ones accessed through Climate Consultant, seen in Figure 6.

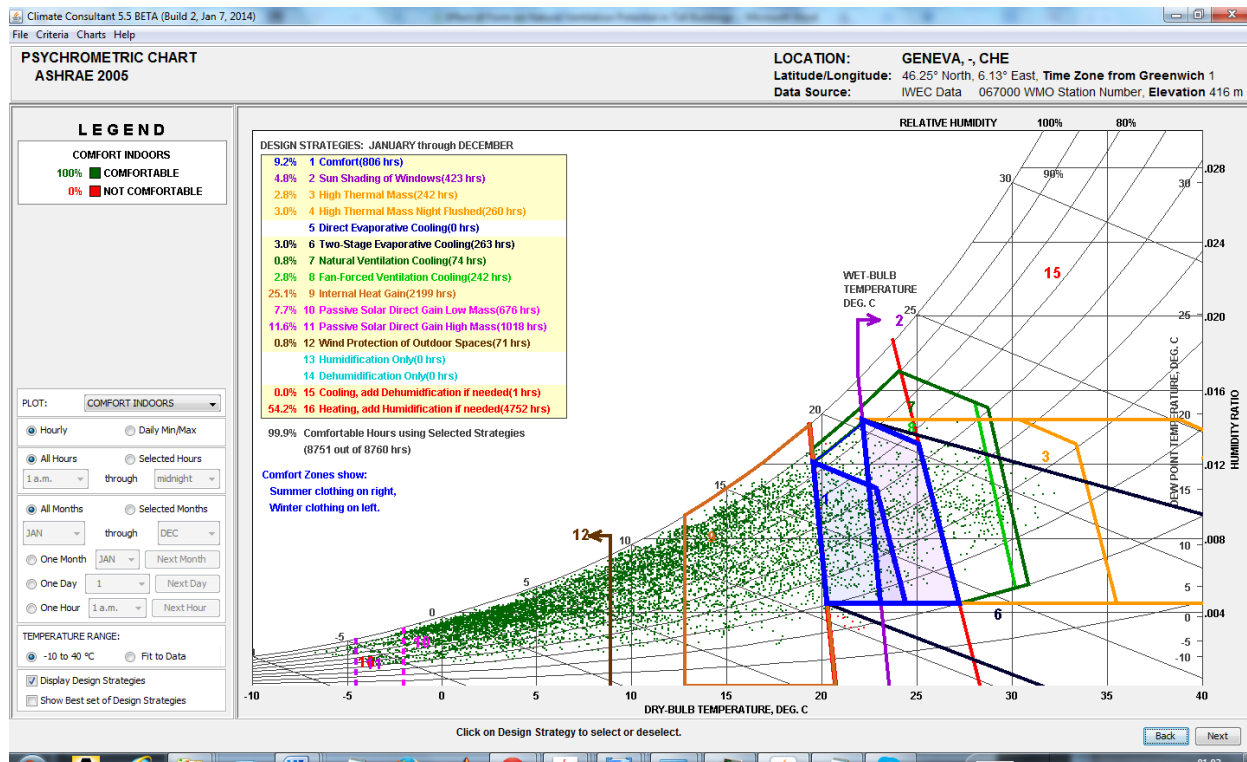

Figure 6. Example psychrometric chart showing Geneva, Switzerland

Nevertheless, the guidelines in this paper offer a starting point, should the architect wish to give residents the feeling of control over their environment that operable windows uniquely offer, without compromising the environmental or structural performance.

As can be seen, many of the possible combinations present trade-offs. Therefore, future research directions could include how to optimize for both natural ventilation and aerodynamic performance, i.e., weighing the trade-offs of increasing the size of the side of the building facing the predominant wind for natural ventilation purposes, even though shaping and sizing the same face for aerodynamic loading would require making it smaller for ventilation. Finding a middle ground between the two constraints in a quantitative approach using further air flow and energy simulations could lead to more specific recommendations for how to make natural ventilation via operable windows in structurally efficient tall buildings feasible.

References

- Alaghmandan, M. and Elnimeiri, M. Reducing Impact of Wind on Tall Buildings through Design and Aerodynamic Modifications (Architectural and Structural Concepts to Mitigate Wind Effect on Tall Buildings). in Proc. AEI Architectural Engineering Conf., pp. 847-856., 2013
- Al-Kodmany, K. and Ali, M.M., The future of the city: Tall buildings and Urban Design, WIT Press, 2012
- Barnes, J. and Hendricks, J. "The Bow, Calgary", CTBUH Journal 2013, Issue III
- Brager, G.S., G. Paliaga, and R. de Dear "Operable Windows, Personal Control and Occupant Comfort", ASHRAE Transactions, Vol. 100, Part 2., 2004, pp.17-35

- Brass, K., Wood, A., and Carver, M. "Tall Buildings in Numbers: 2012 A Tall Building Review", CTBUH Journal 2013, Issue I
- J. Felkner, E. Chatzi, T. Kotnik, "Interactive Particle Swarm Optimization for the Architectural Design of Truss Structures", 2013 IEEE Symposium Series on Computational Intelligence, IEEE SSCI 2013, April 16-19, Singapore
- HOK, [ONLINE] "Workplace Strategies that Enhance Performance, Health and Wellness", <http://www.hok.com/thought-leadership/workplace-strategies-that-enhance-human-performance-health-and-wellness/>, accessed, February 2014
- Kareem, A., Spence, S., Bernardini, E., Bobby, S., and Wei, D. "Using Computational Fluid Dynamics to Optimize Tall Building Design", CTBUH Journal 2013, Issue III
- Krem, M., Hoque, S., Arwade, S., and Brena S., "Structural Configurations and Building Energy Performance", J of Architectural Engineering, Vol 19, No 1, pp.29-40, 2013
- Mak, C.M., Niu, J.L., Lee, C.T., and Chan, K.F. "A numerical simulation of wing walls using computational fluid dynamics", Energy and Buildings, Volume 39, Issue 9, Sep 2007, pp 995-1002
- Nicol, J. Fergus, and Michael A. Humphreys. "A stochastic approach to thermal comfort-Occupant behavior and energy use in buildings." ASHRAE Transactions, Vol. 110, Part 2, 2004, pp. 554-568.
- Oldfield, P, "Embodied carbon and high-rise". in Proc. of the CTBUH 9th World Congress Council on Tall Buildings and Urban Habitat. pp. 614-622, 2012
- Sivakumar, P, Palanthandalam-Madapusi, H., and Dang, T. "Control of Natural Ventilation for aerodynamic high-rise buidlings", Building Simulation, Vol.3., Issue 4, pp.311-325, 2010
- Wood, Antony and Salib, Ruba. 2012. Natural Ventilation High Rise Buildings SALIB & WOOD. Abingdon, Oxon: Routledge.
- Yeang, K. "The green skyscraper", Prestel, New York, 1999
- Young, A., Annereau, N., Butler, A. and Smith, B. "The Leadenhall Building, London", CTBUH Journal 2013, Issue II.

Implication of building energy modeling (BEM) and adaptive model to assess the efficiency of multi storied apartments in composite climate of north India

Shailza Singh*, Dr. P.S Chani and Prof. S.Y Kulkarni

Department of Architecture and Planning, Indian Institute of Technology, Roorkee, India shailzaiitr09@gmail.com

Abstract

The paper is focused on identifying factors affecting the energy consumption & comfort conditions of multi-storied apartments in composite climate of north India. The findings reveal that the residents are very well adapted to their thermal environment and are comfortable at a broader temperature range (22.5–30.6 °C). The TSV-PMV difference was observed to be fairly significant for the winter and summer period, i.e. 5°C and 1.1°C respectively whereas marginally differed for the annual data i.e. 0.6° C. The energy-use evaluation through simulations has identified solar gain through ext. windows to be the most important contributor to the internal gains. The heat conduction through walls & glazing has also shown the highest values for heat gains. Building design, especially, the orientation and WWR is observed to be significantly affecting the thermal behaviour of the building envelope, and are suggested to be the prime focus while designing naturally ventilated buildings in this climatic zone.

Keywords: thermal comfort, adaptive model, simulation, apartments, naturally ventilated

1. Introduction

India shows the lowest figures in energy consumption and carbon emissions as compared to many developed countries but these figures are projected to rise by almost seven times of the present level, by the year 2030 (WBCSD,2008). At present India ranks fifth in primary energy consumption (India Energy Portal); approximately 75% of which is expended on Indian households (Pachauri and Spreng, 2002). One important aspect of energy utilization is the thermal behavior of the building envelope (Zain et al., 2007), which directly influences the indoor comfort levels. It is envisaged that with the growing disposable incomes, the energy demand for better indoor thermal environment (through space heating /cooling) will continue to rise in the foreseeable future. Reports show that energy expended on cooling load in residential buildings accounts for up to 45% of the total electricity consumption in India (BEE, 2007). Thus, it becomes important to frame standards to control the energy consumption, especially, when the construction spending of residential sector is expected to grow at a rate of 10% by the year 2018 (Asia Construction Outlook, 2013).

India is a country with highly variable climate at macro-scale (from region to region) and at micro scale (within a region). And, the existing energy codes (i.e. the ECBC standards) follow a prescriptive component based approach where energy efficiency guidelines are quite ambiguous and nonspecific for each of the climatic zone. Also,

the operational thermal comfort standards are based on static ASHRAE standards (BIS, 2005], which does not consider the adaptive behavior and its effect on thermal perception of the subjects. Field studies in tropical climate (Humphrey, 1978; Sharma & Ali, 1985; Nicol, 1999; Mallick, 1996; Heidari, 2002; Indraganti, 2010 etc.) have shown a broader comfort range and high comfort temperature using adaptive model, as opposed to what is suggested by the current standards.

In quantifiable terms, thermal comfort is related to environmental and personal variables which are, in turn, dependent on the building parameters (both physical and thermal). The prime contextual variable in adaptive model and energy efficiency is temperature. It strongly controls the thermal attitudes of the people and the way building is designed. But the case in unconditioned residential buildings is much more complicated and dynamic as compared to other building typologies. Indoor environment varies within a small time scale (Peeters et al., 2009) and depends upon the constantly changing outdoor physical variables, internal heat gains and the ventilation rates. Many thermal comfort researches have been stimulated with the current drive to achieve energy efficiency (Jaggs, 2000; Kolokotsa et al., 2009; Griego et al., 2012). But, the literature on field studies of thermal comfort and energy efficiency (especially residential buildings) in India is still not very profound. Only handful of studies are available on the thermal comfort (Indraganti, 2010; Rajasekar et al., 2010; Pellegrino et al., Sharma and Ali, 1986; Singh et al., 2011, 2012) and energy efficiency (Bhatia et al., 2011; Dhaka et al., 2012; Singh et al., 2012) in India. With this growing awareness for a need to reduce the building energy-use and to improve the indoor thermal environment, it becomes increasingly important to seek ways to assess the indoor thermal environment.

The aim of this study is to identify the predictors for energy load and thermal comfort in naturally ventilated multi storied apartments in composite climate of north India. The adaptive approach is employed to analyze the thermal perception of the subjects whereas the thermal behavior of the buildings and its impact on the energy load is evaluated by running simulations using Design Builder's software.

1. Study Area

The study was conducted in five naturally ventilated multi-storied (6-9 storeys) apartments in Roorkee and Chandigarh. The studied area falls under the composite climatic zone and experiences four distinct seasons i.e. winter, summer, monsoon and post monsoon. Roorkee lies in 29° 51' N latitude, 77° 53' E longitude at an altitude of 274m, with temperatures ranging from above 40°C in summer to below 5°C in winters (GAIA). Chandigarh is situated at about 30.44°N & 76.47°E with an elevation of 321 meters (1053 ft). Maximum temperatures can rise up to 44°C in summers and drops to 3.68°C in winters (National Information Centre, Chandigarh). Two buildings, i.e., HV & CV are located in Roorkee whereas three buildings are located in Chandigarh (GMR, BMD & TR). The studied areas and the chosen buildings aptly represent the status quo of real estate development in the north Indian cities.

Outdoor Environmental Conditions

Summer (mid March to mid June): Maximum temperature observed was 41.3°C & 41.5°C for Chandigarh and Roorkee respectively. Diurnal range was highest in summer as compared to other seasons with standard deviation of 5.8 for Chandigarh

and Roorkee (Table 1). Mean temperature was 30.01°C in Chandigarh and 27.31°C in Roorkee. Relative Humidity (RH) varied moderately with the mean of 61% (SD= 3.2) in Chandigarh and 64.9% (SD=2.69) in Roorkee.

Winter (November to February): Mean outdoor temperature in Chandigarh was 15.1°C, with a minimum and maximum of 5°C and 25.1°C (& standard deviation, SD= 2.1). For Roorkee the figures didn't vary much with the mean of 16.2°C and SD of 1.6 (min.= 7.5°C and max.=26°C). RH varied moderately with the mean of 42.8% (SD= 3.9) in Chandigarh and 40% (SD=3.4) in Roorkee.

Monsoon & Retreating Monsoon (mid June to mid October): In monsoon RH reached to a maximum value of 100% (98% in Chandigarh and 100% in Roorkee). Mean temperature observed was 28.3°C and 28.7°C in Chandigarh and Roorkee respectively. Moderately high temperature (reaching max. up to 36°C, details in Table 1) paired with high humidity made the environmental conditions quite stuffy in this season.

Table1 Annual Temperature and Relative Humidity

	Chandigarh				Roorkee			
	Mean	Min	Max	StDev	Mean	Min	Max	StDev
Tout	24.1	7.5	41.5	6.7	24.5	5.0	41.3	7.8
RH(%)	58.7	29.0	98.0	14.7	58.4	30.0	100.0	13.3

Tout- Mean Monthly outdoor temperature ; RH- Relative Humidity

2.1 Survey

A Class II level longitudinal survey was conducted to analyze the thermal responses of the subjects, and to establish the temperature which people find comfortable. In total 54 apartment units are visited and 82 subjects were interviewed on the monthly basis for the year of 2012. About 29 males (~35%) and 53 females (~ 65%) participated in the survey. The age group varied from 8-80 years having 11 young subjects (13%), 54 middle age subjects (65%) and 18 old age subjects (22%). This study collated a dataset of 984 in total. The male and female average age of subjects is 39.2 years and 39.8 years, respectively. All the subjects were living in the surveyed flats for over a period of year or more and were assumed to be naturally acclimatised to the climate.

The clothing patterns of people in India vary dramatically, mainly owing to the cultural diversities from region to region. In north India, females mostly wear 'salwar-kameez', whereas, men prefers shirt/T-shirt with trousers/shorts/pyjamas in summers. In winter period, insulation layers of sweater/jacket/shawl, caps, muffler & other woollen wears' are most commonly used. Figure 1a &b shows the typical winter and summer clothing of males and females in north India. New generation is mostly influenced by the western outfits, and thus the clothing patterns are progressively changing. The participant's metabolic rate (met) and clothing insulation (clo) were estimated using numerical met/clo values in accordance with the ASHRAE Standard 55. As the 'clo' value for salwar-kameez was not available it was estimated using: $I_{cl} = 0.00103W - 0.0253$ where, I_{cl} = clothing insulation and W = weight of the garment in grams (g) (Indraganti, 2010). It is important to note that for Indian ensembles (mostly women clothing i.e. *sari* and *salwar-kameez*), the 'clo' values need to be scientifically validated and, therefore, the intrinsic errors involved with the estimated clo values needs to be explored for the same. The insulation of salwar-kameez was found to be

0.28 (cotton) and 0.47 (woollen). During the survey, the annual clo level ranged between 0.3 to 2.2 clo. Met level also ranged between 0.7 Met (sleeping/resting) to 2.0 Met (standing working) in this survey.

ASHRAE's seven point scale of thermal sensation, ASHRAE's nominal scale of acceptance & Nicol's five point scale of preference were used in this study (Raja et al., 2001). The questionnaire is based on Madhavi (Indraganti, 2010) and designed in English, as phrases with check boxes for response, refer (APPENDIX). Physical environmental variables, i.e., air temperature (T_a), relative humidity (RH), air velocity (A_v) and globe temperature (T_g) are measured for all the occasions during the survey. MH 3350- Thermo Hygrometer is used to measure T_a (using TFS0100) & indoor globe temperatures using TYP101; whose probe was inserted in a black-painted table tennis ball (about 40mm diameter). Handheld Digital Vane Thermo Anemometer (Type 93460) is used to measure air movement. Fig2a shows the instruments used for the survey. In summer and monsoon period, fans are the main source for convective cooling, though; windows and doors are also effectively used. Therefore, the effect of air movement (fans or evaporative coolers in most of the cases) is measured with respect to the position of the subjects while conducting the interview. Vane anemometer is held perpendicular to the direct source of air movement to evaluate its effect on the thermal sensation of the subjects.

All the measurements were made close to the respondent and at 1.1m level, refer Fig2b. Local meteorological stations (IMD, Chandigarh) and observatories (National Hydrology Centre, Roorkee) were approached for the outdoor environmental data. In order to investigate the individual changes, only those subjects are included who participated for all the twelve months. In addition to the thermal responses and physical variables; the questionnaire focused on collecting data on hourly consumption of heating /cooling appliances, occupancy details etc. for creating the baseline models for the energy simulations.



Figure 1a. Winter clothing



Figure 1b. Summer clothing



Figure 2a. Temperature Probes and Anemometer

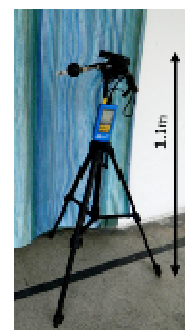

Figure 2b. Instrument setup at 1.1m level

2.2 Simulation Arrangement: Baseline Model and Validation

Design Builder's (DB) v.3.0.0.105 is employed to evaluate the energy performance and thermal behaviour of the surveyed buildings. The consumption of energy in a building is related to the physical variables, occupancy schedules and operation schedules of various appliances (Haberl et al., 1996). In order to create a representative simulated environment for the surveyed buildings, a wide range of information was collected; including architectural drawings (with site details, construction details), monthly utility bills, hourly consumption of the appliances, occupancy details, tenancy details etc. Measured data and real building information is used to assign simulation input values for walls, roof, windows etc. The operation schedules for lighting, heating & cooling system, occupancy etc. are framed on the basis of responses received during the questionnaire survey.

2.2.1 Building Characteristics:

All the buildings were RCC structures with the infill of brick masonry (230mm) and cement plastering on both the sides of the wall. Roofs are typically reinforced concrete slabs with a layer of bitumen felt/ MW Glass wool with a thermal resistance of $R=0.4-.48$ ($m^2 K$)/W. Floors are typically concrete slabs with tile finish or stone chipping/marble finish/Kota stone finish. The windows are all clear, single pane glazing with an aluminum/wooden frame. Table 2 gives the detail of thermal properties of the structural elements of the surveyed buildings.

2.2.2 Model Validation:

The use of measured data and real building information avoids the chances of error. There are few limitations, though, to create a simulated environment that best represents the real one. The energy models are typically very complex and are time consuming & analyst-specific (Eisenhower et al., 2013; Reddy, 2006). It, therefore, becomes necessary to validate the baseline model using certain criteria. The 'Percentage error' is used to validate the baseline model for monthly as well as annual data using Equation (1):

$$\% \text{ Error} = (y \text{ simulated} - y \text{ measured}) / y \text{ measured} \times 100 \quad (1)$$

Although, it is preferred to have hourly data for calibrating the baseline model but the system preferred in India for metering the consumption units is either monthly or bimonthly. So, monthly utility bills of all the buildings are collected from the concerned authorities (local government electricity board) for a maximum of two consecutive years. The billing data includes the monthly kWh consumptions of all the dwelling units (DU). The percentage error between the simulated energy consumption and measured data is within the acceptable tolerances of $\pm 15\%$ for annual data and $\pm 25\%$ for monthly data (Reeves et al., 2012).

Table 2. Detailed summary of thermal properties of surveyed buildings

Parameters	GMR	TR	BMD	HV	CV
Glazing Type	#U.F=7.1	U.F=7.1	U.F=7.1	U.F=7.1	U.F=7.1
	#SHGC=0.8	SHGC=0.82	SHGC=0.8	SHGC=0.8	SHGC=0.8
	#VLT=.76	VLT=.76	VLT=.76	VLT=.76	VLT=.76

Wall Materials (External)	U.F= 1.9 , #R.V = 0.5	U.F= 1.9, #R.V = 0.5	U.F= 1.9, #R.V = 0.5	U.F= 1.9 #R.V = 0.5	U.F= 1.9 #R.V = 0.5	
Internal Partition	U.F = 2.3 R.V = 0.43	U.F = 2.3 R.V = 0.43	U.F = 2.3 R.V = 0.43	U.F = 2.3 R.V = 0.43	U.F = 2.3 R.V = 0.43	
Roof	U.F= 2.4, R.V = 0.42	U.F= 2.4, = 0.42	R.V	U.F= 2.4, R.V = 0.42	U.F = 2.1 R.V = .48	U.F = 2.1 R.V = .48
# U.F(U-factor)=Thermal conductance,[W/m ² C] , R.V(R-value)=Thermal resistance [m ² .C/W], SHGC=Solar Heat Gain Coefficient Through Glass						

2. Result and Discussion

3.1 Thermal Comfort Analysis

3.1.1 Neutral Temperature

The thermal responses of the subjects are linearly regressed with the globe temperature (T_g) to develop an adaptive model of thermal comfort. A comfort temperature of 26.6 °C is obtained with a significant regression coefficient of 0.77. The broad comfort band of 22.5–30.6 °C, as compared to what is suggested by the current thermal comfort standards in India (i.e. 23-26°C in summer and 21-23°C in winter), suggests that residents are well adapted to their thermal environment as oppose to narrow comfort range as recommended by the National Building Code (NBC). The regression equation obtained for the current study is:

$$TSV = -0.209T_g - 5.556$$

The gradient of the slope indicated that occupants will experience a 1 unit change in their thermal state for every 5.0 °C change in T_g . The outdoor temperature, as assumed, has also shown a significant regression coefficient of 0.8 with TSV. The seasonal evaluation of the thermal responses have indicated that subjects are least sensitive to changes in globe temperatures in winters (with a lower regression slope of 0.148/°C) as compared to other seasons. The observed differences might be explained by the seasonal variability in the usage pattern of controls as a response to changes in the temperature. Also, the thermal acceptability of the subjects is observed to be high even when the comfort votes were low or while voting discomfort (i.e. ‘hot’ or ‘warm’ in summer & monsoon and ‘cool’ or ‘cold’ in winters).

The adaptive behaviour of the occupants is an important consideration while assessing the thermal comfort temperatures of naturally ventilated residential buildings. The superfluous comfort temperatures (-1.5°C, 8.2°C, -11°C etc.) can, thus, be aptly ascribed to the variable use of adaptive controls, as mentioned in the studies previously (Indraganti, 2010; Nicol et al., 1999; Rijal et al., 2010). Griffith’s method, as suggested by Nicol (Rijal et al., 2010) is used to modify these unreliable comfort temperatures for each subject using mean comfort vote and mean temperatures. Table 3 gives the detailed summary of estimated Griffith’s neutral temperature of all the surveyed buildings. Four Griffith’s constants, as obtained by Indraganti (0.31), Nicol et.al. (0.25 & 0.33) and finally the one obtained in this study (0.21), are used for the analysis.

Table 3. Griffith's Comfort Temperature

Building	Regression		Mean		Griffith's			
	Tn	r	Tgm	TSm	TnG1	TnG2	TnG3	TnG4
					0.31	0.25	0.33	0.21
HV	24.5	0.9	26.1	0.1	25.8	25.8	25.8	25.7
CV	27.3	0.9	26.7	0.0	26.7	26.7	26.7	26.7
BMD	25.1	0.9	26.6	0.0	26.5	26.5	26.5	26.4
TR	28.3	0.9	26.4	-0.1	26.6	26.6	26.6	26.7
GMR	25.9	0.9	26.7	0.0	26.7	26.7	26.7	26.6

3.1.2 Comparison of PMV and TSV

Fanger's predicted mean vote (PMV) is estimated using CBE's comfort calculator (CBT, Thermal Comfort Tool) to compare the results with the subjective thermal responses (TSV). In most of the observed events, PMV was always higher for the warmer period and lower for the cooler period than the actual sensation. Conceivably, the regression of Tg with PMV, for the annual data, yielded a lower comfort temperature (25.9°C) but with a marginal difference of 0.6°C only, refer Table4. However, seasonal evaluation of the TSV-PMV difference was fairly significant for the winter and summer period, i.e. 5°C and 1.1°C respectively, refer Table4. The reliability of the difference can be argued with the inherent errors involved in clo and met estimations, as mentioned in studies before (. It should be noted that, owing to the exposure to extreme temperatures, the adaptive behavior and the thermal expectations of the subjects has adjusted to the wider range of temperature. This has subsequently affected the distribution of the comfort votes when accounting the annual data.

To analyze the strength of the relationship between TSV and PMV, a scatter diagram is plotted between the two, refer Fig 3. It is observed that when the TSV is equal to 0 (or neutral), the predicted thermal sensation is +.13 & + .26 for summer and monsoon and -1.3 for winters, refer Table5. The results, thus, support the argument that the traditional PMV model overestimates the thermal sensation, similar to the findings of previous studies (Indraganti, 2010; Rajasekar et al., 2010; Beizae et al., 2011; Kotbi et al., 2012). It should be noted that the higher discrepancy is observed in the winter period and this can be attributed to the lower thermal sensitivity (as mentioned in the previous section). Humphreys (Heidari, 2002) has mentioned that the lower values of the slope from field studies suggests the adaptive control of the thermal environment by the occupants. In the winter period, closed doors (60%) and windows (90%) along with the heater usage (approx. six hours) minimised the adverse effect of outdoor environmental conditions. Also, the estimated clo variability is observed to be higher when subjects voted on the cooler side of TSV scale, similar to the observations drawn by Schiavon and Lee (Schiavon, 2013). It, is thus deduced from the above findings that the adaptive behaviour of the subjects significantly affects their thermal perception in naturally ventilated buildings.

Table 4. TSV-PMV Seasonal Evaluation

		0.21		Griffith's Tn	
	Tom	Tgm	Tn		PMV residual (°C)
			Observed	Predicted	
Winter	15.6	18.6	26.3	31.5	5.2
Summer	28.8	30.1	25.4	26.5	1.1
Monsoon	28.6	30.8	27.7	28.7	0.9
ALL	24.3	26.5	26.6	25.9	-0.6

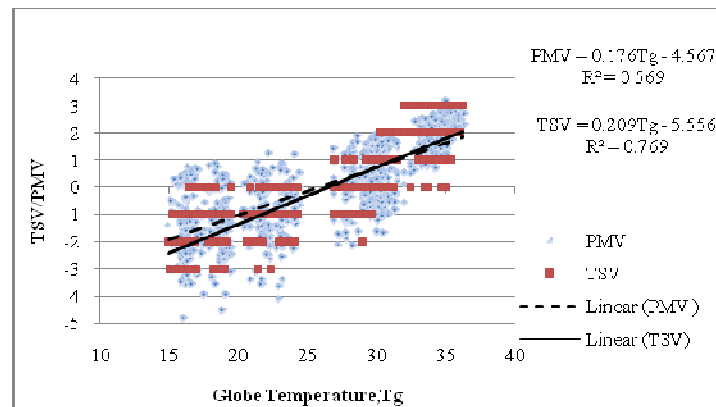

Figure 3. Variation of TSV and PMV with Tg

Table 5. PMV Residual for all seasons

	PMV: TSV	TSV	PMV residual
Winter	PMV=-0.098TSV-1.3	0	-1.3
Summer	PMV=.782TSV+.129	0	+.129
Monsoon	PMV=.507TSV+.263	0	+.263

3.1.3 Thermal sensation as a function of measured variables

The adaptive use of the controls is a key variable in the thermal evaluation of the subjects. The choices made by the subjects in response to the thermal discomfort are directly or indirectly influenced by the physical and personal variables (Nicol and Humphreys, 2002; Baker and Standeven, 1996). Thermal sensation of the subjects is, therefore, evaluated as a function of the measured variables (i.e. Tg, Av, RH, met, clo) to identify the significant predictors. Table 6 gives the summary of correlations of the measured variables with TSV.

Globe temperature (Tg), air movement (Av) and clothing (clo) have significantly correlated with TSV (refer Table 6). Air velocity is observed to be linearly increasing when subjects have voted on the warmer side of TSV scale (refer Fig 7). This suggests that subjects are controlling the air flow using mechanical ventilation (fans, evaporative coolers etc.) or natural ventilation (door, windows etc.) to combat the

thermal discomfort. The socio-cultural constraint has considerably affected the adaptive use of clothing. Clo level is also observed to be decreasing with increase in warmer sensation, till it reaches a minimal acceptable limit. The variability in ‘clo’ level increased as subjects voted for discomfort on a TSV scale (i.e. -3,-2, 2&3). As shown in Fig.8, less variation is observed in ‘clo’ level when subjects voted on the warm side of the TSV scale (i.e. from 1 to 3) as compared to when subjects voted on the cooler side of TSV scale. Relative humidity has shown a moderate correlation, but the results are assumed to be generic in nature and needs to be explored in monsoon period on hourly basis. Met level has not shown any significant relation with any of the physical variable or with the comfort votes. Based on the above findings temperature, air velocity and clo are identified as the predictors for thermal evaluation in naturally ventilated buildings.

Table 6. Correlation of Measured variables with TSV

	TS: Tg	TS: clo	TS: Av	TS:RH	TS: met
Winter	0.4	-0.5	-0.1	-0.2	-0.1
Summer	0.8	-0.6	0.7	0.1	0.1
Monsoon	0.8	-0.2	0.5	0.2	0.0

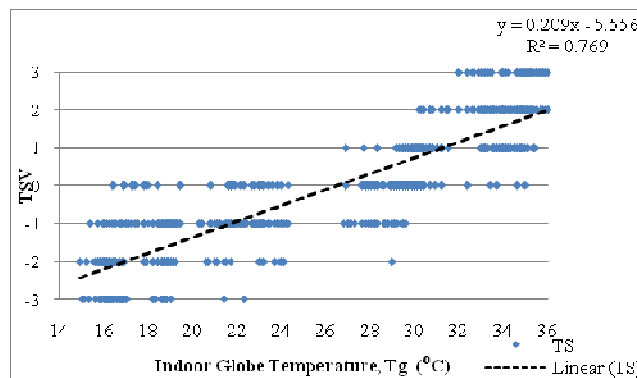

Figure 6. Tg vs TSV

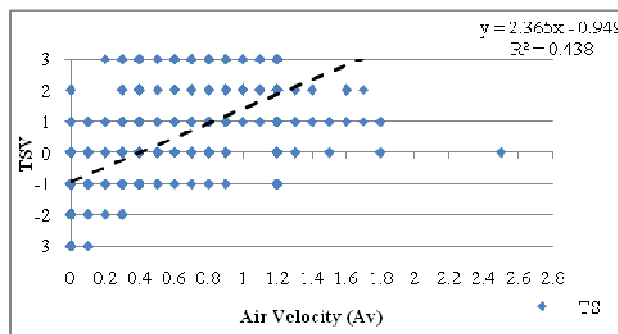

Figure 7. Air velocity vs TSV

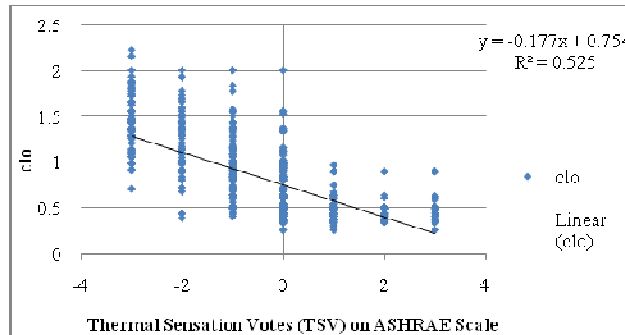

Figure 8. Clo vs TSV

3.2 Energy-use analysis

3.2.1 Thermal behavior of Building Envelope

Major amount of energy in buildings is consumed to either flush out the extra heat or to restore heat. Thus, it is vital to control the rate of heat flow through the building envelope to maintain the zone temperature within the comfort limits. In composite climate, cooling load is maximum and the major amount of energy in naturally ventilated building is used to regulate the convective cooling (using fans, doors, windows etc.) or to cool down the indoors (using A/c). The simulation results have indicated that the source of heat gain/ loss can help in identifying the design parameters that needs to be focused to optimize energy use and thermal comfort. Solar gains through exterior windows and zone sensible cooling have shown the maximum internal gains in the baseline models. Whereas, the heat flows through the building envelope in the baseline was maximum through glazing, walls and air infiltration. As the baseline models have already been validated using percentage error (for monthly data); the results are assumed to be the representing the existing thermal environment of the surveyed buildings. Fig 9&10 shows the distribution of the internal gains and the heat conduction gains of the baseline models.

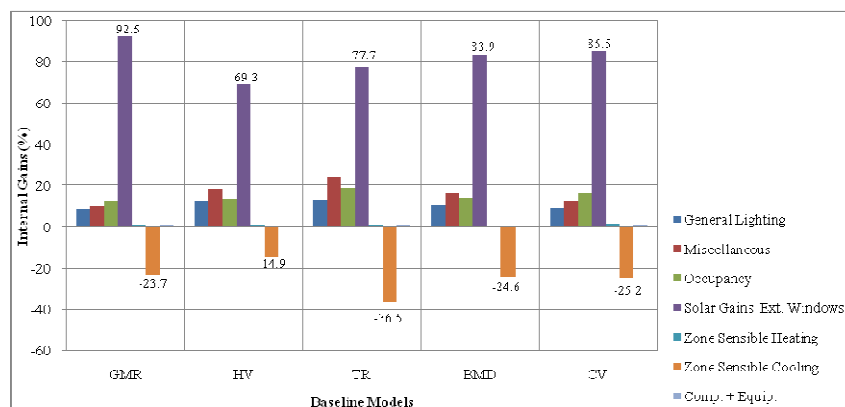

Figure 9. Distribution of internal gains in the baseline models

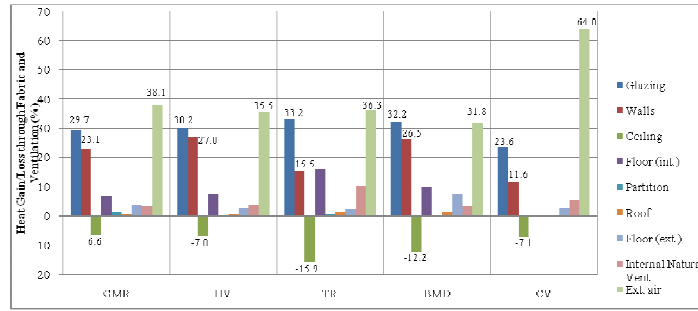

Figure 10. Distribution of heat gain/ loss through building envelope in the baseline models

3.2.2 Building Design :Effect on heat gain/loss

a.Orientation

Orientation is an important consideration while evaluating the solar gains through the building envelope, as the heat flows through the facade facing different directions is unequal (Sustainable Building –Design Manual Volume II).The analysis has shown that the building orientation and the window to wall ratio (WWR) for the corresponding direction have significantly affected the heat flows through the building envelope and the resultant energy loads. GMR has shown the highest and HV the lowest solar gains through the ext. windows. The E-W orientation with an overall WWR of 0.4 explains the lower gains for HV, refer Table 6. The solar gains through ext. windows in HV are, thus, allowed only when required (winter period) and restricted in the warmer period, refer Fig11, an ideal case for composite climate.

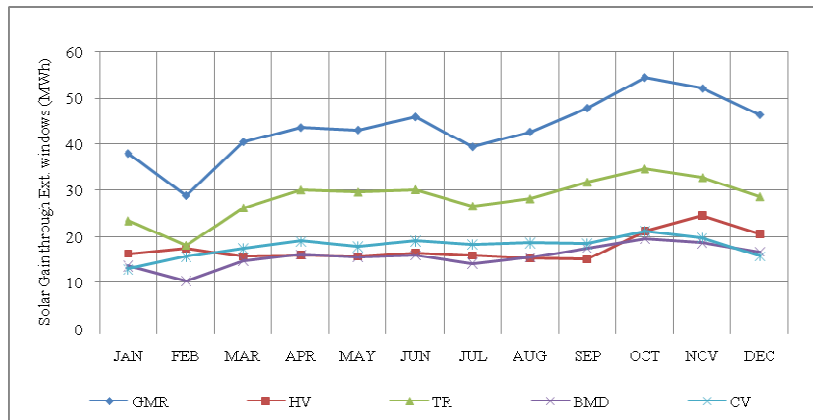

Figure 11. Solar Gain through Exterior Windows

Table 6. Summary of WWR and S/V ratio of surveyed building

	Wall Area	Volume	Window Area	S/V	WWR
BMD	3806.4	10627.2	526.4	0.4	0.5
CV	2499.7	9048.8	502.7	0.3	0.8
TR	2816.6	17238.2	839.9	0.2	0.9
HV	4841.3	12976.3	560.3	0.4	0.4
GMR	6470.6	17382.9	964.3	0.4	1.9

On the other hand, the higher solar gains in GMR can be attributed to its building form. The CFD analysis (using an extended Design Builder's application) is employed to analyze the difference in the heat flows for each block. Fig 12a shows the key plan of GMR, divided into four blocks (i.e. Aa, Ab, Ba & Bb) on the basis of orientation of the longer axis. The block 'Ba' & 'Bb' with the orientation along N-S & E-W axis, respectively, has shown the major effect of exposure to solar radiation with respect to its orientation, refer Fig 12 b, c, d, e. Heat conduction gain in 'Ba' block is higher than block 'Bb', owing to the exposure of longer facade to the east direction (having maximum solar radiation in summer). The average zone temperature of 'Ba' is approximately 1°C higher than the block on E-W axis, i.e. Bb, for both the floor levels, refer Table7. The zones facing the prevalent north westerly winds are observed to be cooler in blocks 'Ba' and 'Bb'.

Table7. Average zone temperature of LF and TEF of GMR

Average Zone Temperature	Bb	Bb	Ba	Ba	Ab	Ab	Aa	Aa
	TEF	LF	TEF	LF	TEF	LF	TEF	LF
	36.5	36.3	37.5	37.2	37.3	37.0	37.1	36.9

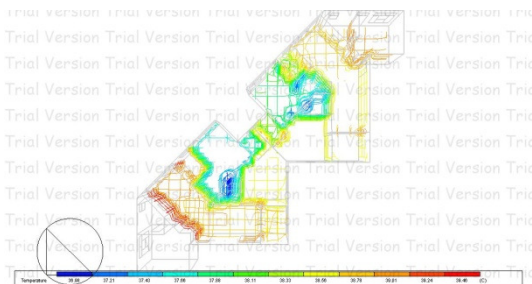
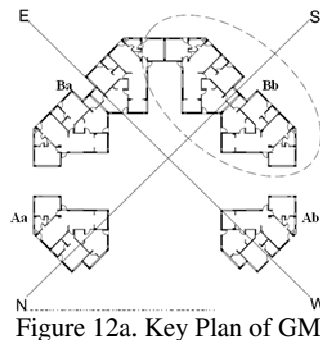

Figure 12b. GMR Ba Block (LF)

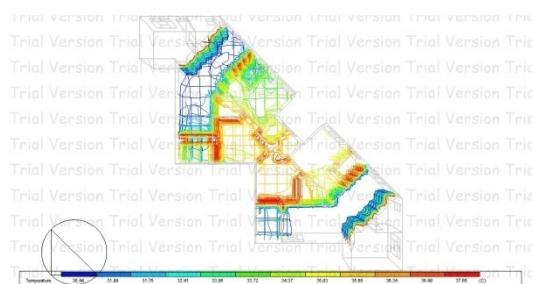

Figure 12c. GMR Bb Block (TEF)

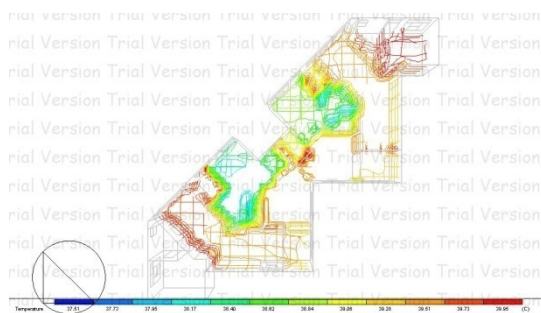

Figure 12d. GMR Ba Block (LF)



Figure 12e. GMR Bb Block (TEF)

b. Glazing Area: WWR

In tropical climates, north orientation has a brief exposure to solar radiation (early mornings and late afternoons) whereas east & west receives the maximum solar radiation during summer (Sustainable Building –Design Manual Volume II).Therefore the WWR for the façade of respective directions, i.e. with maximum solar radiations, have been summarized in the Table 8. It is important to note that the type of glazing used in the surveyed building is mostly single-pane unit with wooden frames. This has not only contributed to the solar gains and heat conduction gains (refer Fig 6 & 7) but has significantly affected the heat gains through external air or infiltration. As all the buildings are naturally ventilated, the heat gain through external air is estimated using ‘Calculated Natural Ventilation’ option in Design Builder’s software. CV, among other buildings, have shown the highest values (refer Fig 7) and the observed difference can be attributed to its high WWR (0.8). The WWR of east and west facades (recipient of maximum solar radiation) in CV is also comparatively higher, refer Table8. Therefore, the amount of heat entering through the windows is more for a given a volume of the space, which is less in case of CV.

Table 8. WWR of facades with maximum solar radiation

	E	W	NW	NE	SE	SW
BMD			0.16	0.07	0.16	0.07
CV	0.23	0.22				
TR			0.44		0.44	
HV		0.05				
GMR	0.22	0.23	0.12	0.20	0.30	0.20

4 Conclusion

The study has been conducted W14103with a prime focus to identify predictors that affects the energy loads and thermal comfort of naturally ventilated multi-storied apartments in composite climate of north India. By inculcating two different approaches of building evaluation, the study has fairly achieved the same. A comfort temperature of 26.6 °C with a comfort band of 22.5–30.6 °C has been derived. This suggests that the residents are well adapted to their thermal environment as oppose to narrow comfort range as recommended by the National Building Code (NBC). PMV is also observed to be overestimating the thermal sensation as oppose to the actual thermal sensation votes. The TSV-PMV difference was observed to be fairly significant for the winter and summer period, i.e. 5°C and 1.1°C respectively whereas marginally differed for the annual data i.e. 0.6°C.. Temperature (globe temperature), air velocity and clo are identified as the predictors for thermal evaluation in naturally ventilated buildings. Building orientation, WWR, building form has significantly influenced the internal gains and the heat conduction gains. GMR has shown the highest and HV the lowest solar gains through the ext. windows. The E-W orientation

has shown the minimum solar gains and heat gains whereas, east & west has shown the maximum. Building form has also considerably effected the orientation of the building; which further has affected the exposure to solar radiations of longer facades. The average zone temperature of 'Ba' (along N-S axis) is observed to be 1°C higher than the block on E-W axis, i.e. Bb. WWR has not only effected the solar gains but also the heat gains through infiltration. CV with significantly high WWR and low S/V ratio has shown maximum heat gains through external air.

References:

- Asia Construction Outlook (ACO), AECOM and Davis Langdon KPK 2013.
- Baker, N., Standeven, M. (1996), Thermal comfort for free-running buildings. *Energy and Buildings* 23, pp 175–182.
- BEE. Energy Conservation Building Code 2007. Bureau of Energy Efficiency.
- Beizaee, A., Firth, S.K. (2011). A Comparison of Calculated and Subjective Thermal Comfort Sensation in Home and Office Environment. In: *Network for Comfort and Energy Use in Buildings, People and Buildings*. Arup UK, 23rd September 2011, London.
- Bhatia, D A. , Garg, V. , Mathur, J. (2011), Calibrated simulation for estimating energy savings by the use of cool roof in five Indian climatic zones, *Journal of Renewable and Sustainable Energy* 3(2), art. no. 023108.
- BIS, National Building Code 2005, Bureau of Indian Standards, 2005.
- Deb, C., Ramachandraiah, A. (2010), Evaluation of thermal comfort in a rail terminal location in India. *Building and Environment*, 45(11), pp 2571-80.
- Dhaka, S., Mathur, J., Garg, V. (2012), Combined effect of energy efficiency measures and thermal adaptation on air conditioned building in warm climatic conditions of India, Report No: IIIT/TR/2012/-1, Centre for IT in Building Science, International Institute of Information Technology, Hyderabad.
- Eisenhower, B., O'Neill, Z. (2013), Leveraging the analysis of parametric uncertainty for building energy model calibration. *Building Simulation*, 6(4), pp 365-377.
- Feriadi, H., Wong, N.H. (2004), Thermal comfort for naturally ventilated houses in Indonesia. *Energy and Buildings*, 36(7), pp 614-26.
- Griego, D., Krarti, M., Hernández-Guerrero, A. (2012), Optimization of energy efficiency and thermal comfort measures for residential buildings in Salamanca, Mexico. *Energy and Buildings*, 54, pp 540–549.
- Haberl, J. , Sparks, R., Culp, C. (1996), Exploring new techniques for displaying complex building energy consumption data. *Energy and Building*, 24(1), pp 27-38.
- Heidari, S., Sharples, S. A. (2002), Comparative analysis of short-term and long-term thermal comfort surveys in Iran. *Energy and Buildings*, 34(6), pp 607–614.
- India Energy Portal (IEP). GOI.
- India: Sustainable Urban Development. GAIA: A Multi-Media Tool for Natural Resources Management and Environmental Education.
- Indraganti, M. (2010), Thermal comfort in naturally ventilated apartments in summer: findings from a field study in Hyderabad, India. *Applied Energy*, 87(3), pp 866-883.

- Indraganti, M. (2010), Using the adaptive model of thermal comfort for obtaining indoor neutral temperature: findings from a field study in Hyderabad, India. *Building and Environment*, 45(3), pp519-536.
- Jaggs, M., Palmer, J. (2000), Energy performance indoor environmental quality retrofit — a European diagnosis and decision making method for building refurbishment. *Energy and Buildings*,31(2), pp 97–101.
- Kolokotsa, D., Pouliezios, A., Stavrakakis, G., Lazos, C. (2009), Predictive control techniques for energy and indoor environmental quality management in buildings. *Building and Environment*, 44 (9), pp1850–1863.
- Kotbi, M., King, S., Prasad, D. (2012), Validating Fanger's PMV model in a “real” field study. In: Windsor conference, The changing context of comfort in an unpredictable world Cumberland Lodge, Windsor, UK, 12-15 April 2012.
- Mallick, F.H. (1996), Thermal comfort and building design in the tropical climates. *Energy and Buildings*, 23(3), pp 161–167.
- National Informatics Centre, Chandigarh Administration. Department of Information Technology , UT, Chandigarh.
- Nicol, J.F., Humphreys, M.A. (2002), Adaptive thermal comfort and sustainable thermal standards for buildings. *Energy and Buildings*, 34, pp 563-572.
- Nicol, J.F., Raja, I.A., Allaudin, A., Jamy, G.N.(1999), Climatic variations in comfortable temperatures: the Pakistan projects. *Energy and Buildings*, 30(3),pp 261-79.
- Pachauri, S., Spreng, D. (2002), Direct and indirect energy requirements of households in India. *Energy Policy*, 30, pp 511–523.
- Peeters, L., de Dear, R.J. , Hensen, J. , D’haeseleer, W.(2009), Thermal comfort in residential buildings: Comfort values and scales for building energy simulation, *Applied Energy* ,86,pp 772–780.
- Pellegrino, M., Simonetti, M., Fournier, L.(2012), A field survey in Calcutta. Architectural issues, thermal comfort and adaptive mechanisms in hot humid climates. In: Windsor Conference, The changing context of comfort in an unpredictable world .Cumberland Lodge, Windsor, UK, 12-15th; April 2012.
- Raja, I.A., Nicol, J.F., McCartney, K.J., Humphreys, M.A. (2001), Thermal comfort: use of controls in naturally ventilated buildings. *Energy and Buildings*,33(3), pp 235-244.
- Rajasekar, E., Ramachandraiah, A. (2010), Adaptive comfort and thermal expectations - a subjective evaluation in hot humid climate. In: Windsor conference, Adapting to Change: New Thinking on Comfort. Cumberland Lodge, Windsor, UK, 9-11th; April 2010.
- Reddy, T.A. (2006),Literature review on calibration of building energy simulation programs: Uses, problems, procedures, uncertainty and tools. *ASHRAE Transactions*, 112 (1), pp 226 -240.
- Reeves, T., Olbina, S. (2012), Validation of Building Energy Modeling Tools: Ecotect™, Green Building Studio™ And IES<VE>™. In:IEEE Conference, Winter Simulation Conference, Berlin, Germany, 9th-12th December,2012.
- Rijal, H.B., Yoshida, H., Umemiya, N.(2010), Seasonal and regional differences in neutral temperatures in Nepalese traditional vernacular houses. *Building and Environment*, 45(12), pp 2743-53.
- Schiavon, S., Lee, K.H. (2013), Dynamic predictive clothing insulation models based on outdoor air and indoor operative temperatures. *Building and Environment* 59, pp 250-60.

- Sharma, M.R., Ali, S. (1986), Tropical summer index and a study of thermal comfort of Indian subjects. *Building and Environment*, 21(1), pp11-24.
- Singh, M.K. , Mahapatra, S. , Atreya, S.K. (2011), Adaptive thermal comfort model for different climatic zones of North-East India. *Applied Energy*,88, pp 2420–2428.
- Singh, S., Chani, P. S. and Kulkarni, S. Y. (2012), Energy Assessment of Multi-Storied Apartments in Roorkee. *International Journal of Engineering and Technology*, 4(6), pp 684-688.
- Sustainable Building- Design Manual: sustainable building design practices, Volume II,TERI, ICAEN TERI.
- Tyler, H., Stefano, S., Alberto, P., Dustin, M., and Kyle, S. (2013) , CBE Thermal Comfort Tool. Center for the Built Environment, University of California Berkeley.
- WBCSD (World Business Council for Sustainable Development: Summary Report). *Energy Efficiency in Buildings – Facts and Trends*’. LAFARGE and United Technologies Corporation; 2008.
- Zain, Z. M., Taib, M. N. and Baki, S.M.S (2007), Hot and humid climate: prospect for thermal comfort in residential building, *Desalination*, 209(1-3), pp 261-268.

WINDSOR CONFERENCE 2014

COUNTING THE COST OF COMFORT

SESSION 6

Outdoor comfort and Urban Heat Island effect

Invited Chairs: Roberto Lamberts and Chungyoon Chun

Proceedings of 8th Windsor Conference: *Counting the Cost of Comfort in a changing world* Cumberland Lodge, Windsor, UK, 10-13 April 2014. London: Network for Comfort and Energy Use in Buildings, <http://nceub.org.uk>

Residual analysis of UTCI predictions on outdoor thermal sensation survey data

Peter Bröde¹, Eduardo L. Krüger² and Dusan Fiala³

1 IfADo – Leibniz Research Centre for Working Environment and Human Factors, Dortmund, Germany, correspondence e-mail broede@ifado.de;

2 Technological University of Parana, Curitiba, ekruger@utfpr.edu.br;

3 ErgonSim — Comfort Energy Efficiency, Stuttgart, Germany, dfiala@ergonsim.de

Abstract

The Universal Thermal Climate Index UTCI assesses the interaction of ambient temperature, wind, humidity and radiant fluxes on human physiology in outdoor environments on an equivalent temperature scale. It is based on the UTCI-Fiala model of human thermoregulation and thus also allows for thermal comfort prediction. Comparing UTCI predictions to thermal sensation votes recorded on the 7-unit ASHRAE scale in outdoor comfort surveys with 1685 respondents in Curitiba and 567 in Glasgow, respectively, yielded negligible bias and less than one unit root-mean squared error (rmse) for Curitiba, but a noticeable underestimation of actual thermal sensation votes (bias=-0.73) with increased rmse=1.44 in Glasgow. Residual analyses revealed that the factors age, gender, body composition, site morphology (open space, street canyon), climatic state (comfort/discomfort) and clothing behaviour only explained a small portion of the error variance, which was dominated to over 95% by residual inter-individual variability. Adding historical weather information from the previous day to the Glasgow data gave superior information compared to longer time lags and helped to reduce the residual variance to 89%. Those numbers underpin current limitations in individual thermal comfort prediction, while UTCI performance appears reasonable at the population level.

Keywords: thermal comfort, outdoor environment, survey, model, error analysis

1 Introduction

The Universal Thermal Climate Index UTCI aims for the assessment of the outdoor thermal environment in the major fields of human biometeorology (Jendritzky et al., 2012). UTCI summarises the interaction of ambient temperature, wind, humidity and radiant fluxes on human physiology. The dynamic physiological responses are simulated by an advanced multi-node model of human thermoregulation (Fiala et al., 2012) coupled with a model of adaptive clothing choice in urban populations (Havenith et al., 2012), which also considers the distribution of the clothing over different body parts, and the reduction of thermal and evaporative clothing resistances caused by wind and the movement of the wearer, who is assumed walking at 4 km/h (1.1 m/s) on the level. UTCI values are presented on an equivalent temperature scale. This involved the definition of a reference environment with 50% relative humidity (but vapour pressure not exceeding 20 hPa), with still air and radiant temperature equalling air temperature, to which all other climatic conditions are compared.

The operational procedure provides simplified algorithms for computing UTCI values from air temperature, wind speed, mean radiant temperature and water vapour pressure and was completed by an assessment scale establishing UTCI threshold values that define different categories of thermal stress from extreme cold to extreme heat, with UTCI values from 18 to 26 °C complying to the thermal comfort zone (Bröde et al., 2012a).

We have already presented the UTCI operational procedure (Bröde et al., 2010) and its application to outdoor thermal comfort surveys from Curitiba, Brazil, and Glasgow, UK (Krüger et al., 2012) at previous Windsor Conferences. For the interviews carried out in Curitiba, the observed clothing insulation was in good agreement with the UTCI-clothing model. Also the actual thermal sensation votes were well predicted by the UTCI-Fiala model simulations for UTCI reference conditions with negligible averaged error (bias) and less than one unit root-mean squared errors (rmse) on the 7-unit thermal sensation scale (ISO 10551, 1995). Detailed simulations considering the individual climatic and clothing conditions did not further improve the predictions indicating the validity of the assumptions underlying the UTCI model for the surveys in Curitiba (Bröde et al., 2012b).

However, we had observed larger negative bias (i.e. underestimation) and rmse for the thermal sensation votes from Glasgow in connection with less clothing insulation worn than assumed by the UTCI model. Therefore, with focus on the Glasgow survey in this paper,

- we analyse how the residues of UTCI predictions on thermal sensation depend on personal characteristics (gender, age, body composition) and urban site morphology (open spaces vs. street canyons);
- we study the influence of clothing choice on the residues by detailed simulations with the UTCI-Fiala model; and
- we study experience related effects on thermal sensation (Nikolopoulou et al., 2001; Nikolopoulou & Steemers, 2003) by adding meteorological data and UTCI values recorded days, weeks and months before each survey to the data base.

2 Materials and Methods

Here, we briefly review the field surveys' methodology, as detailed descriptions have already been given elsewhere (Bröde et al., 2012b; Krüger et al., 2012).

2.1 Outdoor surveys

Field measurements with concurrent administration of comfort questionnaires were carried out in Curitiba, Brazil (25°26'S, 49°16'W, 917m amsl, subtropical climate in elevation) and in Glasgow, UK (55°51'N, 04°12'W, 0-100m amsl, maritime temperate climate). The same team leader directed both field studies, thus ensuring compatibility of the employed procedures. In both locations, surveys were carried out in pedestrian areas during daytime (typically from 10am to 3pm local time) with portable weather stations recording air temperature, relative humidity, air velocity and globe temperature, from which mean radiant temperature was calculated (ISO 7726, 1998).

We applied a standard comfort questionnaire to collect personal information like age, gender, height and weight. Participants rated their thermal sensations using a symmetrical 7-unit two-pole scale ranging from -3='cold' over 0='neutral' to +3='hot' (ISO 10551, 1995) and intrinsic clothing thermal insulation was determined from the worn items according to standardised tables (ISO 9920, 2007).

2.2 Data analysis and statistics

Only data of permanent residents (i.e. living for more than 6 months in the city) who had spent at least 15 min outdoors before the interview were considered eligible, thus 567 responses from Glasgow and 1685 from Curitiba were included in the analysis.

UTCI values were computed from measured air temperature, humidity, air velocity and mean radiant temperature and predictions of dynamic thermal sensations (DTS) averaged over 2 h exposure time were obtained from the output of the UTCI-Fiala model (Bröde et al., 2012a; Fiala et al., 2012). Prediction error was defined as the difference of DTS to the actual thermal sensation vote, with negative values indicating underestimation and positive values representing overestimation. We calculated the averaged error (bias), root-mean squared error (rmse) and Pearson's correlation coefficient (rp) to assess the deviations between predicted and measured thermal sensation votes.

General additive models with locally estimated smoothing functions (LOESS) and 95%-confidence intervals (CI) were computed to describe the average course of clothing insulation, of thermal sensation and of the prediction error considering the potentially non-linear relationships with air temperature and UTCI, respectively. For comparing models with different predictors, Akaike's Information Criterion (AIC) was used to assess the goodness-of-fit (Zuur et al., 2009).

The influence of potential modifiers on the prediction error was assessed by computing bias, rmse and correlation coefficients for subgroups defined by city, gender and other classifying factors as described below. We calculated body mass index (BMI) from weight and height and classified the persons' body composition as 'underweight', 'normal', 'overweight' or 'obese' (Bröde et al., 2012b; WHO, 1995) according to WHO guidelines, which were also applied to build age subgroups as below 25 years (young), between 25 and 64 (adult) and above 64 (elderly). Two urban site morphology groups were defined: 'street canyons', where most of the surveys took place in both samples, and 'open spaces or crossroads'. We used the thermal state classification provided by UTCI with the thermal comfort zone corresponding to UTCI values from 18 to 26 °C, cold discomfort below 18 °C and warm discomfort above 26 °C (Bröde et al., 2012a). The deviation of worn clothing insulation ($I_{cl_{obs}}$) from the UTCI-clothing model ($I_{cl_{mod}}$) was determined and percentage deviation was calculated as $(I_{cl_{obs}} - I_{cl_{mod}}) / I_{cl_{mod}} * 100$. Percentage deviation was classified in three levels as more than 20% below (<-20% UTCI) or above (>+20% UTCI) or within $\pm 20\%$ of UTCI clothing insulation.

Variance components of prediction error attributable to the above random factors were obtained separately for both cities and for the total sample, respectively, by mixed model ANOVA using SAS® Version 9.2 (Littell et al., 1996).

Historical weather records for time periods preceding the Glasgow campaigns were obtained from Weather Underground (www.wunderground.com) for the weather station East Renfrewshire (IGLASGOW1, 55.78 °N, 4.42 °W) and comprised records in five minute intervals of air temperature, wind speed, relative humidity and solar radiation. Mean radiant temperature was estimated for these records using the RayMan software (Matzarakis et al., 2010). This information was then used to calculate UTCI values and from the recordings obtained between 10am and 3pm (corresponding to the period of interviewing) daily averages were calculated. So we obtained averaged historical UTCI values 1, 3, 7, 14, 28 and 56 days prior to the actual campaign thus covering in a logarithmic manner periods from days, weeks to

almost two months. The differences of actual to historical UTCI were used as predictors of the residual prediction error of thermal sensation by fitting LOESS models. For the variance component analysis, these differences were classified in intervals ± 2.5 °C (actually as cool/warm as in previous period), < -2.5 °C (actually cooler than in previous period), $> +2.5$ °C (actually warmer), with the thresholds corresponding to the inter-quartile range for 1 day lagged values.

3 Results and Discussion

Clothing thermal insulation showed considerable inter-individual variation, but on average decreased with increasing air temperature in both study areas (Fig. 1A). It was in good agreement with the UTCI-clothing model, especially at high temperatures in Curitiba and at lower temperatures in both cities. However, greater differences between cities were observed from 18 to 22 °C with people in Glasgow consistently wearing lower insulating clothing at identical temperatures than in Curitiba. Overall we observed mean deviations (percentage deviations) from the UTCI-clothing model of 0.02 clo (2%) in Curitiba and -0.10 clo (-12%) in Glasgow. Thermal sensations also varied largely and increased with temperature as well as with UTCI (Fig. 1B). They were higher in Glasgow compared to Curitiba, especially in the temperature range which corresponded to the larger deviations in clothing insulation.

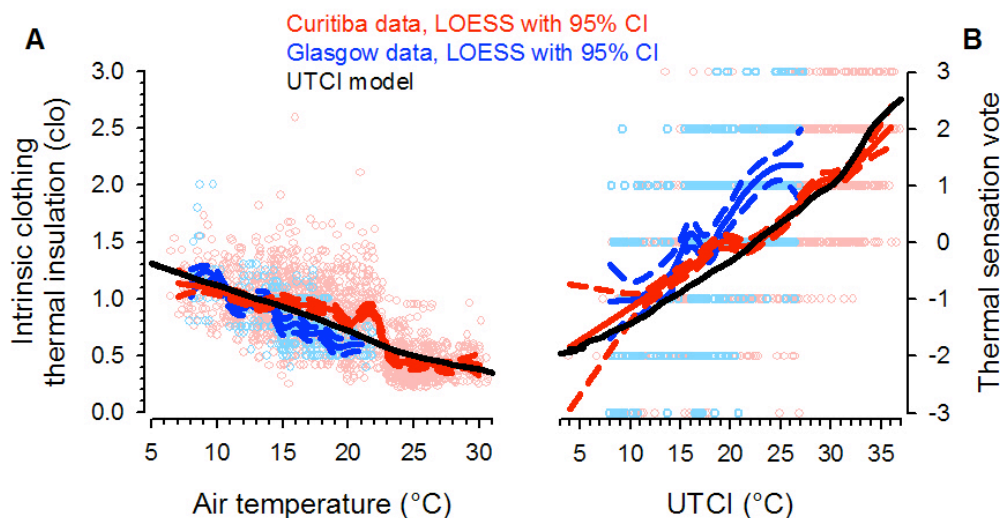

Figure 1. Individual recordings in Glasgow (blue) and Curitiba (red) superimposed by locally estimated smoothing splines (LOESS) with 95% confidence intervals (CI) for (A) clothing thermal insulation related to air temperature and (B) thermal sensation votes (-3: 'cold', ..., 0: 'neutral', ..., +3: 'hot') related to UTCI. Black lines indicate predictions by the UTCI clothing model (A) and by the UTCI-Fiala model for reference climatic conditions (B)

3.1 Prediction error and model complexity

Table 1 compares the prediction errors in thermal sensation for both cities and the whole sample calculated for UTCI reference environmental conditions, for actual meteorological input data, and additional for actual meteorological data also considering the worn clothing insulation. Generally, bias was negligible and rmse was less than one unit on the 7-unit thermal sensation scale for Curitiba, whereas thermal sensations were noticeably underestimated (bias < -0.7) with greater rmse in Glasgow. However, in all locations the prediction for the reference environment performed as well as those for actual weather data. This is in line with the requirements formulated for UTCI and other thermo-physiological indices, that identical index values represent the same physiological strain (Jendritzky et al., 2012).

Table 1. Averaged errors (bias), root-mean-squared errors (rmse) and Pearson correlation coefficient (rp) by study area between the observed thermal sensation and the dynamic thermal sensation predicted by the UTCI-Fiala model for the UTCI reference environment (REF), for actual climatic conditions (ACTUAL) and for actual climate with individually recorded clothing insulation (INDIV clo).

Model	Curitiba (n=1685)			Glasgow (n=567)			Total (n=2252)		
	<i>bias</i>	<i>rmse</i>	<i>rp</i>	<i>bias</i>	<i>rmse</i>	<i>rp</i>	<i>bias</i>	<i>rmse</i>	<i>rp</i>
REF	-0.13	0.96	0.62	-0.73	1.44	0.46	-0.28	1.10	0.54
ACTUAL	-0.15	0.95	0.63	-0.78	1.47	0.46	-0.31	1.10	0.54
INDIV clo	-0.18	1.05	0.56	-1.03	1.67	0.33	-0.39	1.24	0.46

Interestingly, Table 1 also indicates that using a more complex model which also incorporated actual clothing insulation yielded deteriorated predictions. As a consequence from these results, we restricted our subsequent analyses on the predictions for UTCI reference conditions.

3.2 Factors influencing the prediction error

There were only small changes in bias, rmse and correlation presented for the different subgroups in Table 2 compared to the overall results (Table 1). Although the BMI categories showed a tendency of increased underestimation error with increasing obesity, the variance component analysis (Fig. 2) revealed that all factors and their interactions accounted only for a very small portion of total variance, which was dominated to more than 95% by residual inter-individual variability.

Only the discrepancy between Glasgow and Curitiba showed up as a significant contribution of “city” in the results for the total sample, thus corresponding to other surveys with e.g. higher neutral temperatures observed in Greece compared to the UK or Germany (Nikolopoulou & Lykoudis, 2006).

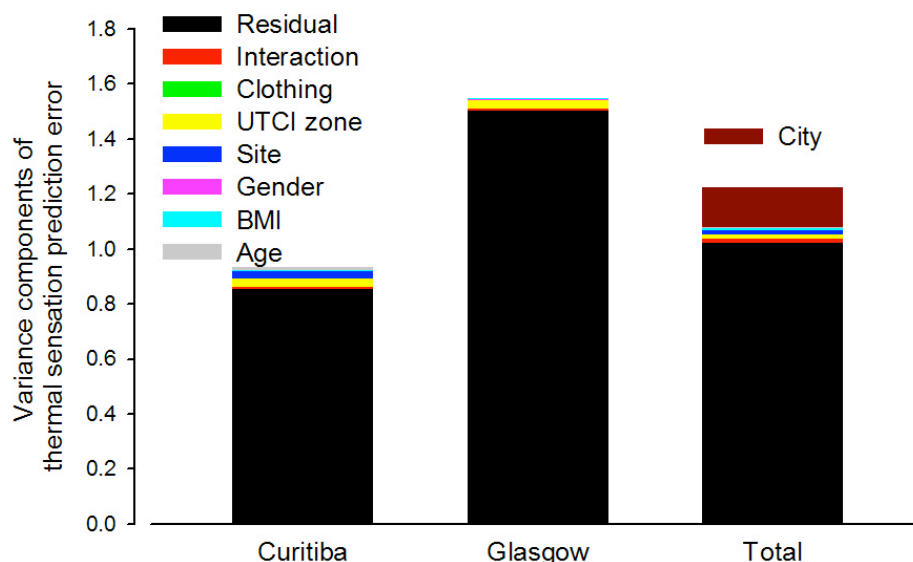

Figure 2. Partitioning of the variance for the error in thermal sensations predicted by the UTCI model into factors corresponding to Table 2 shown separately for the two study locations and the total sample. Note that factor “city” only applies to the total sample and that the contributions of all interactions are summated into a single term

Table 2. Averaged errors (bias), root-mean-squared errors (rmse) and Pearson correlation coefficient (rp) by study area between the observed thermal sensation votes and the dynamic thermal sensation predicted by the UTCI-Fiala model for UTCI reference environment (REF) in relation to the modifying factors age, body composition (BMI), gender, site morphology, thermal comfort/discomfort zone according to UTCI and deviation of worn clothing insulation from the UTCI model (Actual clo).

Factor	Curitiba				Glasgow				Total			
	<i>n</i>	<i>bias</i>	<i>rmse</i>	<i>rp</i>	<i>n</i>	<i>bias</i>	<i>rmse</i>	<i>rp</i>	<i>n</i>	<i>bias</i>	<i>rmse</i>	<i>rp</i>
<i>Age</i>												
young	501	-0.24	0.98	0.66	142	-0.73	1.43	0.48	643	-0.35	1.10	0.60
adult	1032	-0.09	0.94	0.61	333	-0.73	1.41	0.43	1365	-0.24	1.08	0.53
elderly	152	-0.10	0.96	0.50	92	-0.77	1.54	0.54	244	-0.35	1.21	0.41
<i>BMI</i>												
underweight	44	0.00	0.91	0.69	16	-0.48	1.47	0.74	60	-0.13	1.09	0.64
normal	912	-0.10	0.94	0.64	283	-0.67	1.39	0.51	1195	-0.24	1.07	0.57
overweight	537	-0.17	0.97	0.59	189	-0.77	1.44	0.40	726	-0.32	1.12	0.50
obese	192	-0.21	0.99	0.62	79	-0.93	1.57	0.34	271	-0.42	1.19	0.50
<i>Gender</i>												
female	718	-0.12	1.01	0.63	222	-0.65	1.46	0.46	940	-0.25	1.13	0.56
male	967	-0.14	0.91	0.62	345	-0.79	1.43	0.47	1312	-0.31	1.07	0.53
<i>Site morphology</i>												
Crossroads & Open Spaces	580	0.03	0.98	0.68	197	-0.76	1.53	0.35	777	-0.17	1.14	0.56
Street Canyon	1105	-0.22	0.95	0.59	370	-0.72	1.38	0.52	1475	-0.34	1.07	0.53
<i>UTCI zone</i>												
cold disc.	492	-0.31	1.00	0.32	292	-0.60	1.47	0.26	784	-0.42	1.20	0.31
comfort	624	-0.12	0.89	0.15	261	-0.89	1.40	0.38	885	-0.35	1.07	0.17
warm disc.	569	0.02	0.99	0.36	14	-0.60	1.41	0.42	583	0.00	1.00	0.34
<i>Actual clo</i>												
<-20% UTCI	454	-0.16	0.98	0.58	207	-0.70	1.43	0.44	661	-0.33	1.14	0.50
±20% UTCI	806	-0.10	0.94	0.67	327	-0.78	1.46	0.44	1133	-0.30	1.12	0.56
>+20% UTCI	425	-0.15	0.96	0.53	33	-0.53	1.22	0.79	458	-0.18	0.98	0.54

3.3 Prediction error and historical weather data in Glasgow

Figure 3A illustrates the influence of changes in UTCI compared to prior values with different time lags on thermal sensation prediction error for the survey data from Glasgow. The LOESS functions for greater lags (3 to 56 days) oscillated around the mean bias indicating a limited predictive value. On the other hand, the information from the previous day (lag 1 day) showed a more systematic variation with a reduced underestimation at positive differences, meaning that a cooler day before resulted in less warm sensations of the respondents and thus in smaller negative bias.

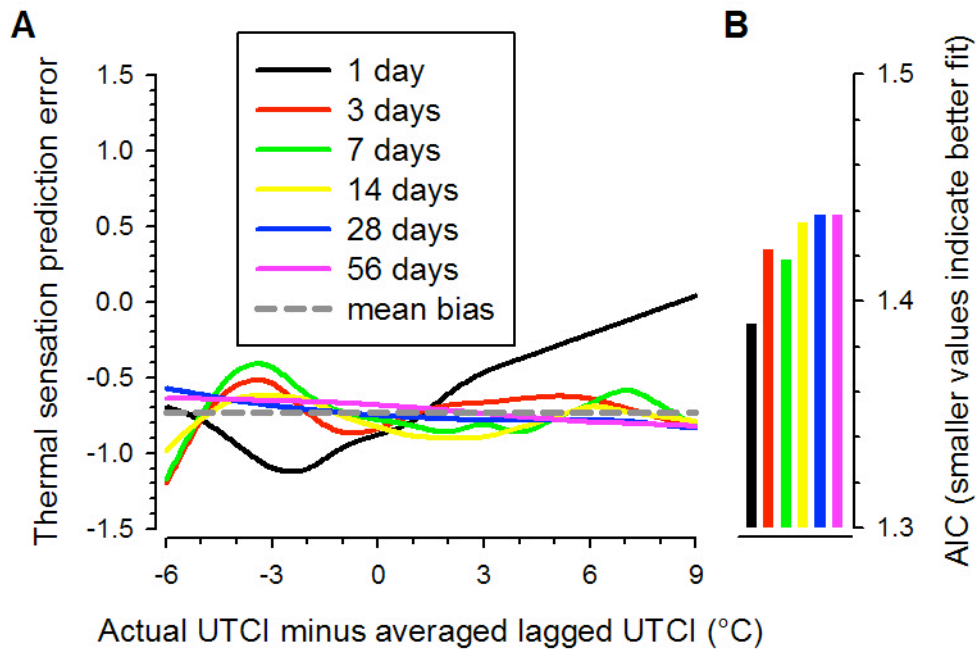

Figure 3. (A): LOESS smoothing functions of the prediction error in thermal sensation related to the difference of actual UTCI to past values averaged over different time lags. The dashed grey line indicates the average bias for the Glasgow data. (B): Akaike's Information Criterion (AIC) for the LOESS functions in (A) with smaller values indicating a superior goodness-of-fit.

The AIC values (Fig. 3B) indicate that 1 day lag information fitted better than longer lag periods. This concurs with regression analyses from earlier studies (Nikolopoulou et al., 2001) showing lower capacity of temperatures recorded at longer time lags for neutral temperature prediction.

Figure 4 presents the prediction error variance components for Glasgow in relative terms pointing out that the consideration of UTCI values from the previous day, in interaction with the other factors, reduced the residual inter-individual variability from over 95% to 89%.

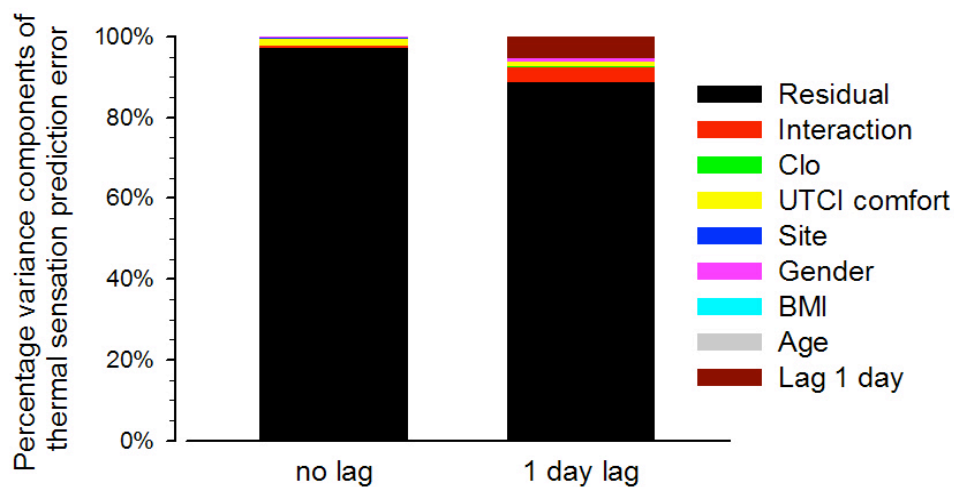

Figure 4. Relative partitioning of the error variance for thermal sensations predicted by the UTCI model for the Glasgow data into factors corresponding to Table 2 (left bar, cf. Fig. 2) and after incorporating the change to UTCI from the previous day (Lag 1 day). Note that factor "Lag" only applies to the right bar and that the contributions of all interactions are summated into a single term.

4 Conclusions

The dynamic thermal sensations calculated by the UTCI-Fiala model for UTCI reference climatic conditions provided predictions of actual thermal sensation votes recorded in outdoor field surveys with an rmse of about 1 unit on the 7-unit thermal sensation scale. Given that thermal sensation votes in the range of ± 1 are applied to define thermal comfort in survey studies (Rossi et al., 2012), this level of accuracy appears reasonable. The prediction error was largely independent of gender, age, body composition, site morphology, thermal status, clothing choice, but thermal sensations in Glasgow were noticeably underestimated compared to Curitiba.

Additional information on prior weather as a surrogate of short-term experience (Nikolopoulou & Steemers, 2003) could only help reducing this bias if it referred to a previous cooler day. It was interesting to note, that explicitly considering individual clothing behaviour in the heat exchange model did not improve the predictions. This might be explainable by inter-individual differences in human thermoregulation which might be interconnected with the choice of clothing.

Though the prediction may be considered acceptable at the population level, the large portion of 90% and more of unexplained inter-individual residual variance indicates current limitations in individual thermal comfort modelling and in considering regional and inter-cultural differences. Recently, attempts to adapt a thermo-physiological model to Asian populations have been made by modifying the passive part of the system, i.e. anthropometry (Zhou et al., 2013). However, given the limited influence of personal characteristics found in our study, it remains questionable, whether such alterations will sufficiently account for psychological influences (Nikolopoulou & Steemers, 2003) or even semantic differences in perceiving thermal comfort in different cultures or regions (Tochihara et al., 2012).

References

- Bröde, P., Jendritzky, G., Fiala, D., Havenith, G., 2010. The Universal Thermal Climate Index UTCI in Operational Use. *Proceedings of 6th Windsor Conference: Adapting to Change: New Thinking on Comfort*, Cumberland Lodge, Windsor, UK, 9 – 11 April 2010. London: Network for Comfort and Energy Use in Buildings.
- Bröde, P., Fiala, D., Blazejczyk, K., Holmér, I., Jendritzky, G., Kampmann, B., Tinz, B., Havenith, G. 2012a. Deriving the Operational Procedure for the Universal Thermal Climate Index (UTCI). *International Journal of Biometeorology*, 56(3), pp 481-494.
- Bröde, P., Krüger, E.L., Rossi, F.A., Fiala, D. 2012b. Predicting Urban Outdoor Thermal Comfort by the Universal Thermal Climate Index UTCI - a Case Study in Southern Brazil. *International Journal of Biometeorology*, 56(3), pp 471-480.
- Fiala, D., Havenith, G., Bröde, P., Kampmann, B., Jendritzky, G. 2012. UTCI-Fiala Multi-Node Model of Human Heat Transfer and Temperature Regulation. *International Journal of Biometeorology*, 56(3), pp 429-441.
- Havenith, G., Fiala, D., Blazejczyk, K., Richards, M., Bröde, P., Holmér, I., Rintamaki, H., Ben Shabat, Y., Jendritzky, G. 2012. The UTCI-Clothing Model. *International Journal of Biometeorology*, 56(3), pp 461-470.
- ISO 10551, 1995. *Ergonomics of the Thermal Environment - Assessment of the Influence of the Thermal Environment Using Subjective Judgement Scales*. Geneva: International Organisation for Standardisation.

ISO 7726, 1998. *Ergonomics of the Thermal Environment - Instruments for Measuring Physical Quantities*. Geneva: International Organisation for Standardisation.

ISO 9920, 2007. *Ergonomics of the Thermal Environment - Estimation of Thermal Insulation and Water Vapour Resistance of a Clothing Ensemble*. Geneva: International Organisation for Standardisation.

Jendritzky, G., de Dear, R., Havenith, G. 2012. UTCI - Why another Thermal Index? *International Journal of Biometeorology*, 56(3), pp 421-428.

Krüger, E.L., Bröde, P., Emmanuel, R., Fiala, D., 2012. Predicting Outdoor Thermal Sensation From Two Field Studies in Curitiba, Brazil and Glasgow, UK Using the Universal Thermal Climate Index (UTCI). *Proceedings of 7th Windsor Conference: The Changing Context of Comfort in an Unpredictable World*, Cumberland Lodge, Windsor, UK, 12 – 15 April 2012. London: Network for Comfort and Energy Use in Buildings.

Littell, R.C., Milliken, G.A., Stroup, W.W., Wolfinger, R.D., 1996. *SAS® System for Mixed Models*. Cary, NC: SAS® Institute Inc.

Matzarakis, A., Rutz, F., Mayer, H. 2010. Modelling Radiation Fluxes in Simple and Complex Environments: Basics of the RayMan Model. *International Journal of Biometeorology*, 54(2), pp 131-139.

Nikolopoulou, M., Baker, N., Steemers, K. 2001. Thermal Comfort in Outdoor Urban Spaces: Understanding the Human Parameter. *Solar Energy*, 70(3), pp 227-235.

Nikolopoulou, M., Lykoudis, S. 2006. Thermal comfort in outdoor urban spaces: Analysis across different European countries. *Building and Environment*, 41(11), pp 1455-1470.

Nikolopoulou, M., Steemers, K. 2003. Thermal comfort and psychological adaptation as a guide for designing urban spaces. *Energy and Buildings*, 35(1), pp 95-101.

Rossi, F.A., Krüger, E.L., Bröde, P., 2012. Definição de faixas de conforto e desconforto térmico para espaços abertos em Curitiba, PR, com o índice UTCI. *Ambiente Construído* 12(1), pp. 41-59.

Tochihara, Y., Lee, J.Y., Wakabayashi, H., Wijayanto, T., Bakri, I., Parsons, K. 2012. The Use of Language to Express Thermal Sensation Suggests Heat Acclimatization by Indonesian People. *International Journal of Biometeorology*, 56(6), pp 1055-1064.

WHO 1995. *Physical status: the use and interpretation of anthropometry. Report of a WHO Expert Committee*. WHO Technical Report Series No. 854. Geneva: World Health Organisation.

Zhou, X., Lian, Z., Lan, L. 2013. An Individualized Human Thermoregulation Model for Chinese Adults. *Building and Environment*, 70, pp 257-265.

Zuur, A.F., Ieno, E.N., Walker, N.J., Saveliev, A.A., Smith, G.M., 2009. Things are not Always Linear; Additive Modelling. In: Zuur, A.F., Ieno, E.N., Walker, N.J., Saveliev, A.A., Smith, G.M., *Mixed effects models and extensions in ecology with R*. New York: Springer, pp 35-69.

Study on Evaluation of Effects of Inhomogeneous Radiant Environment for Pedestrian in Summer Season using a Coupled Numerical Simulation based on CFD Analysis

Shinji Yoshida¹, Taiki Sato², and Masayuki Oguro³

1 University of Fukui, 3-9-1 Bunkyo, Fukui-city, Fukui, Japan, y-shinji@u-fukui.ac.jp;

2 Taisei Corporation, 344-1 Nase, Tozuka, Yokohama, Kanagawa, Japan, stutik00@pub.taisei.co.jp;

3 Taisei Corporation, 344-1 Nase, Tozuka, Yokohama, Kanagawa, Japan, masayuki.oguro@sakura.taisei.co.jp

Abstract

In this paper, we propose a new calculation method for evaluating the inhomogeneous outdoor thermal environment by incorporating a multi-node human thermoregulation model into the simulation method based on CFD analysis of the outdoor thermal environment. We also investigated the effects of weather conditions on the inhomogeneity of the radiant environment and the thermal comfort for pedestrians using the proposed calculation method. Two different weather condition cases are investigated in this study: (1) a scorching hot day and (2) a cloudy day. The multi-node thermoregulation model “JOS” is used in this analysis to investigate the inhomogeneity of the outdoor thermal environment. The analysis confirmed the effectiveness of the proposed method in the evaluation of the inhomogeneity of the thermal comfort in outdoor space.

Keywords: Numerical analysis, Thermoregulation model, Outdoor space, Radiation, Virtual sphere

1 Introduction

In recent years, urbanization has spread all over the world, including Japan, modifying the geometry and land use of the natural environment to that of a built environment. Urbanization alters the surface energy balance of the urban canopy and results in extensive anthropogenic heat release from various sources such as air-conditioners and cars. In Japanese cities, these changes cause the degradation of the outdoor thermal environment during the summer season, in the form of rising air and surface temperatures, weakening wind velocity, etc. This degradation has caused numerous environmental problems including an increase in the risk of heatstroke. Various countermeasures to these problems have been proposed and implemented, such as roadside planting, roof greening, and use of high albedo (reflectivity of solar radiation) paints and water-permeable materials. However, the effectiveness of such countermeasures has not been clearly confirmed. Hence, it is necessary to propose an assessment method to evaluate the effects of the countermeasures against environmental problems.

For this purpose, numerous researchers, including the present authors, have proposed several methods based on the coupled CFD analysis for evaluating outdoor thermal environment. Bouyer et al. (2007) calculated the physiological equivalent temperature

(PET) (Mayer and Höppe, 2008) spatially using the coupled effect of solar radiation, wind flow around obstructions, convective heat transfer from surfaces, and long wave radiation. Bruse (1999) proposed the ENVI-met system, which is based on a numerical meteorological model (1.5 order closure turbulent model based on the work of Mellor and Yamada (1975)) and also analysed outdoor thermal comfort and open space usage with the multi-agent system, which is based on ENVI-met (cf. Bruse, 2009). The present authors have also proposed a coupled simulation method based on computational fluid dynamics (CFD) for predicting the thermal comfort in an outdoor space, with consideration of the effect of thermal environmental conditions such as wind velocity, temperature, humidity, and radiation (Yoshida et al., 2000). Using this method, Yoshida et al. (2006) have also evaluated the effects of various types of green areas on the outdoor thermal environment.

At present, the numerical analysis method has certain drawbacks in that it is difficult to incorporate unsteady and inhomogeneous factors, which include physical environmental factors (instantaneous changes and local distributions of environmental conditions such as solar radiation and wind) and pedestrian activity factors (walking speed, rest time, activity level, and body posture), into the method for the evaluation of outdoor thermal comfort. However, the two-node cylindrical or prismatic human thermoregulation model, which was proposed by Gagge et al. (1986) and is incorporated into the abovementioned numerical analysis method, does not enable us to evaluate the effects of unsteady and inhomogeneous environmental factors on outdoor thermal comfort.

In this study, we propose a method for evaluating the inhomogeneous outdoor thermal environment by incorporating a multi-node human thermoregulation model into the simulation method based on CFD analysis of the outdoor thermal environment. In this paper, we first outline the numerical analysis method, focusing specifically on the details of the radiant computation method. Next, we introduce an application example of this calculation method for the practical evaluation of the outdoor thermal environment during the summer season. This analysis focuses on the investigation of the effects of weather on the inhomogeneity of the radiant environment and the thermal comfort for pedestrians.

2 Outline of method for evaluating outdoor thermal environment

Figure 1 outlines the computational method used for analysing the outdoor thermal environment. Boundary conditions for the CFD analysis coupled with convection and radiation are determined using the input data, as shown in Fig. 1, i.e., meteorological and geometrical data and surface conditions. The spatial distributions of wind velocity, air temperature, radiation, and humidity are estimated using the CFD-analysis-imposed boundary conditions determined using the input data. Outdoor thermal comfort, including unsteady and inhomogeneous factors, is evaluated using the multi-node human thermoregulation model on the results of the CFD analysis.

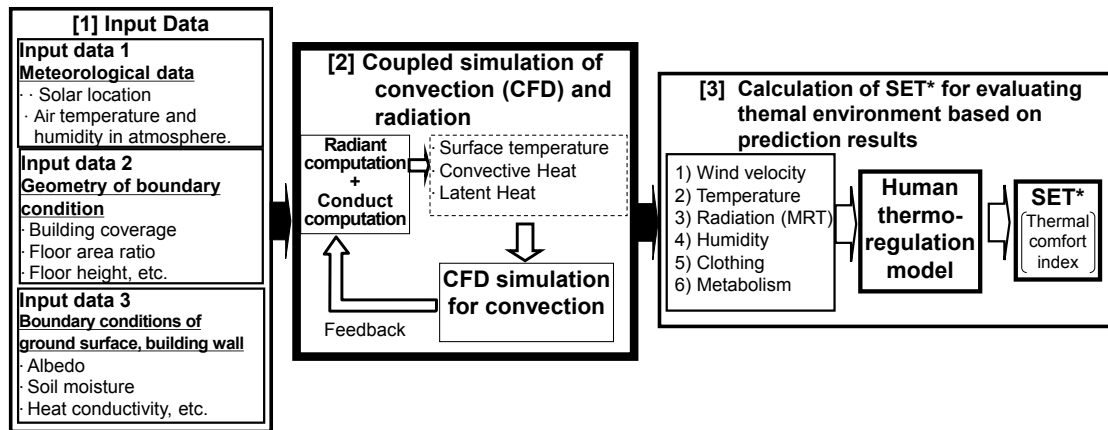

Figure 1. Flowchart for assessing outdoor thermal comfort based on CFD

3 Outline of method for calculating spatial distribution of radiant conditions in outdoor space

Before the calculation of distributions of the mean radiant temperature on each node composing the multi-node thermoregulation model, the spatial distribution of radiant conditions in the outdoor space should be obtained. This section outlines the method of the radiation calculation in the outdoor space. The outline of the method for evaluating the inhomogeneity of a radiant condition is described in the next section.

3.1 Coordinate system

Figure 2 illustrates an example of the coordinate system in an outdoor space. The surfaces of obstacles and the space are divided into small grids into which physical properties and temperature can be considered uniform.

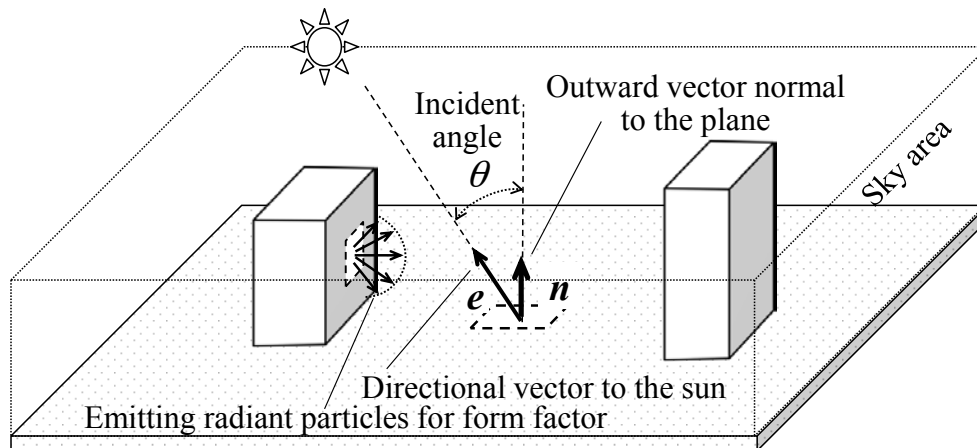

Figure 2. Outdoor coordinate system

3.2 Calculation of form factor using the Monte Carlo method

The Monte Carlo method is used in this study to calculate the form factor. For the details of this calculation method, refer to Omori et al. (1990). A large number of particles, N_{iTotal} , are emitted along the direction determined by Lambert's law from randomly selected points within a surface element i comprising the computational domain. Let N_{ij} be the number of radiant bundles that reach a surface element j .

Division of N_{ij} by N_{iTotal} provides the form factor, or the fraction of radiation leaving i that is intercepted by j , F_{ij} , as shown in Equation (1):

$$F_{ij} = N_{ij}/N_{iTotal}. \quad (1)$$

3.3 Calculation of irradiation ratio

A large number of particles are emitted from the surface element i comprising the computational domain toward the sun; these particles are used to determine whether the sun's rays reach the surface element. Let \mathbf{e} be the unit directional vector toward the sun from the point, and \mathbf{n} be the unit outward vector normal to the plane in which the point is included, as shown in Fig. 2. The vector \mathbf{e} is determined using the solar altitude and azimuth, which are given by the latitude and longitude of the study area and month-day-time. When Equation (2) is satisfied, the sun's rays can reach i when there are no obstacles around the surface:

$$\mathbf{e} \cdot \mathbf{n} = \cos\theta > 0, \quad (2)$$

where θ is the incident angle of the sun's ray to the plane. The particle trajectory is traced to determine whether it reaches the sky area or is intercepted by a surrounding obstacle, such as a building. The former case results in solar irradiation, and the latter in shade. This confirmation repeats a large number of times by randomly changing the emitting point within i . Then, the irradiation ratio γ_i is calculated using Equation (3) as follows:

$$\gamma_i = N_i/N_{iTotal}, \quad (3)$$

where N_i is the number of particles reaching the sky area from i .

3.4 Calculation of heat balance on the ground surface and outside a building

The distributions of the surface temperature T_i at each point are obtained using a heat balance equation at the surface of the ground and outside a building. Let S_i , R_i , H_i , D_i , and LE_i be the absorbed solar radiation gain to a surface i [W], the long-wave radiation gain to i [W], the convection heat transmission at i [W], the conduction to the building or ground [W], and the heat dissipation by evaporation from i [W], respectively. The heat balance equation consists of these elements, as shown in Equation (4):

$$S_i + R_i + H_i + D_i + LE_i = 0. \quad (4)$$

On the left side of Equation (4), a positive value indicates the inflow of energy to i , while a negative value indicates the outflow of energy. The equations for calculating each item in the Equation (4) are expressed as follows.

The absorbed solar radiation gain to i , S_i [W] is calculated using the following equations:

$$S_i = (\alpha_{i\theta}E_{Di} + \alpha_iE_{Si}) + \alpha_i(\sum_{j=1}^N F_{ji}R_{Sj}), \quad (5)$$

$$R_{Si} = (\rho_{i\theta}E_{Di} + \rho_iE_{Si}) + \rho_i(\sum_{j=1}^N F_{ji}R_{Sj}), \quad (6)$$

$$S_{Ti} = (\tau_{i\theta}E_{Di} + \tau_iE_{Si}) + \tau_i(\sum_{j=1}^N F_{ji}R_{Sj}), \quad (7)$$

$$E_{Di} = A_i\gamma_iI_N\cos\theta, \quad (8)$$

$$E_{Si} = A_iF_{iS}I_{SH}, \quad (9)$$

where A_i is the area of i and E_{Di} and E_{Si} are the direct and sky solar radiation gains to grid i [W], respectively. Further, F_{iS} is the form factor from i to the sky, I_N is the direct

solar radiation incident on a normal surface [W], I_{SH} is the sky solar radiation incident on a horizontal surface [W], R_{Si} is the short-wave radiosity or the total short-wave radiation energy flux of a surface per unit area and unit time at i [W], S_{Ti} is the transmitted solar radiation at i [W]. The symbols α_i , ρ_i , and τ_i denote the absorptance, the reflectance, and the transmittance of solar radiation to i , and these values also include ratio of window to the surface.

The long-wave radiation gain to i , R_i [W] is calculated using the following equations:

$$R_i = \varepsilon_i E_i + \varepsilon_i \sum_{j=1}^N F_{ji} R_{Lj}, \quad (10)$$

$$R_{Li} = (1 - \varepsilon_i) E_i + (1 - \varepsilon_i) \sum_{j=1}^N F_{ji} R_{Lj}, \quad (11)$$

$$E_i = A_i \sigma T_i^4, \quad (12)$$

where E_i is the long-wave radiation emitted at i [W], R_{Li} is a long-wave radiosity at i [W], ε_i is the absorption rate of long-wave radiation of i , σ is the Stephan-Boltzmann constant [$\text{W}/(\text{m}^2\text{K}^4)$] ($=5.67 \times 10^{-8} \text{W}/(\text{m}^2\text{K}^4)$).

The mean radiant temperature (MRT) for pedestrians is calculated using R_{Si} and R_{Li} , as we will describe later.

H_i is calculated using Equation (13).

$$H_i = A_i \alpha_C (T_{ai} - T_i), \quad (13)$$

where T_{ai} is the air temperature in the region adjacent to i [K] and α_C is the convective heat transfer coefficient [$\text{W}/(\text{m}^2\text{K})$].

D_i is calculated using Equation (14).

$$D_i = -A_i \lambda (T_i - T_{bi}) / \Delta z, \quad (14)$$

where λ is the heat conductivity of the building material or ground, and T_{bi} is the inside wall or underground temperature at depth Δz , derived by solving the transient heat conduction problem in the solid.

LE_i is calculated using Equation (15).

$$LE_i = A_i L \alpha_w \beta_i (f_a - f_{Si}), \quad (15)$$

where f_a is the water vapour pressure at the region adjacent to i [kPa], f_{Si} is the saturated water vapour pressure at i [kPa], L is the latent heat of evaporation [J/kg], α_w is the moisture transfer coefficient [$\text{kg}/(\text{m}^2 \cdot \text{s} \cdot \text{kPa})$], and β_i is the moisture availability at i .

3.5 Calculation of air-conditioning heat load

For the analysis, discussed later in the paper, the computational domain does not include any building in order to evaluate the individual effect of weather conditions on the inhomogeneity of thermal environment for pedestrians. Hence, the air-conditioning heat load is not calculated in the present analysis. However, this calculation is obviously performed in an actual analysis in the city block. Let Q be the air-condition heat load [W]; Q consists of the heat gain through the wall Q_C [W], the solar radiation gain by penetration through windows Q_S [W], the ventilation heat gain Q_a [W], and the internal heat generation in a building Q_H [W], as described in Equation (16):

$$Q = Q_C + Q_S + Q_a + Q_H. \quad (16)$$

In this equation, a positive value indicates the inflow of energy to the building, and a negative value indicates the outflow. The equations for calculating each item in the Equation (16) are expressed as follows.

Q_C is calculated using Equation (17).

$$Q_C = \sum_{i=1}^m A_i \alpha_I (T_{si} - T_r), \quad (17)$$

where m is the number of surface elements comprising each building, T_r is the indoor temperature [K], T_{si} is the indoor surface wall temperature of the wall at the surface element i comprising inner walls of each building [K], and α_I is the indoor overall (convective + radiative) heat transfer coefficient [W/(m²K)]. T_{si} is obtained by solving Equation (18), which is an unsteady one-dimensional heat conduction equation in the wall.

$$\rho_W C_{pW} (\partial T_{wall} / \partial t) = -(\partial q_{wall} / \partial x), \quad (18)$$

$$q_{wall} = -\lambda (\partial T_{wall} / \partial x), \quad (19)$$

where T_{wall} is the inner temperature of the wall [K]. The symbols C_{pW} , λ , and ρ_W denote the specific heat [J/(kg·K)], the heat conductivity [W/(m·K)], and the density [kg/m³] of the material, respectively.

Q_S is calculated using Equation (20).

$$Q_S = \sum_{i=1}^m S_{Ti}. \quad (20)$$

Q_a is calculated using Equation (21).

$$Q_a = \rho_a \Delta i q_a, \quad (21)$$

where q_a is the amount of ventilation [m³/s], Δi is the enthalpy difference between indoor and outdoor [J/kg], and ρ_a is the density of the air [kg/m³].

Q_H is set to an assumed value.

When the room is air-conditioned, the heat released from the outdoor air-conditioning unit system, A_G is calculated using Equation (22). This value is used as the heat source conditions in the CFD analysis.

$$A_G = Q (1 + COP) / COP, \quad (22)$$

where COP is the coefficient of performance of the air-conditioning system.

4 Outline of the method for analysing inhomogeneous radiation in outdoor spaces

The objective of this study is to incorporate multi-node human thermoregulation models into the abovementioned method in order to evaluate various types of environmental designs for an outdoor space such as a relaxation space in a park and a pedestrian space on a street. A pedestrian in the park and street continually changes walking speed, activity level, posture, and facing direction. These factors instantaneously affect wind and radiant conditions around each segment of the pedestrian's body. Hence, it is necessary to provide environmental conditions together with a relationship between disposition and direction of the thermoregulation model in a computational domain. In this section, we outline the method used to analyse the inhomogeneity of radiant conditions in outdoor spaces.

4.1 Virtual spheres centred on human body

It is necessary to analyse incident short- and long-wave radiation from all directions around the pedestrian in order to include the effects of inhomogeneity on radiation. The method described in this paper is used to calculate the incident radiations on each segment of the thermoregulation model through the surface of a virtual sphere centred on the model. Fig. 3 illustrates the virtual sphere centred on a human body. Spatial distributions of solar and long-wave radiation in the computational domain are calculated on each mesh for the analysis of the outdoor thermal environment, as mentioned above. On each mesh, we consider that a virtual sphere is centred on a human body; the sphere's surface is divided into 266 with each element being 15° in both azimuth and altitude.

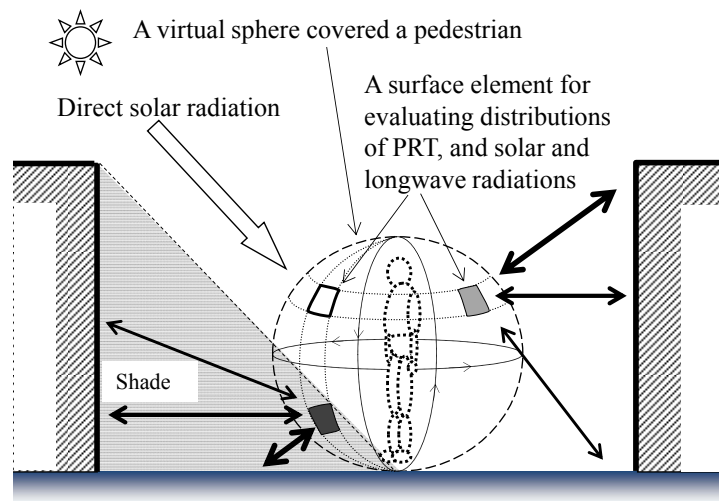

Figure 3. Conceptual figure of virtual sphere centring around a human body.

4.2 Plane radiant temperature and solar irradiation on each surface element comprising the virtual sphere surface

Short- and long-wave radiation and plane radiant temperature (PRT) on each surface element comprising the virtual sphere surface are calculated using the same manner of the radiant analysis method described in the previous section. The plane radiant temperature on each surface element i comprising the virtual sphere surface, T_{Vprt-i} , is calculated using Equation (23) as follows:

$$A_{Vi}\sigma T_{Vprt-i}^4 = \sum_{j=1}^n F_{ji}R_{Lj}. \quad (23)$$

In this equation, A_{Vi} is the area of a surface element i , which comprises the virtual sphere surface [m^2], R_{Lj} is the long-wave radiosity at the surface element j , which comprises the computational domain [W], and is obtained by Equation (10).

The solar radiation reaching i , S_{Vi} [W], is calculated using Equations (24), (25), and (26) as follows:

$$S_{Vi} = E_{VDi} + E_{VSi} + \sum_{j=1}^n F_{ji}S_{Rj}, \quad (24)$$

$$E_{VDi} = A_{Vi}\gamma_i I_N \cos\theta, \quad (25)$$

$$E_{VSi} = A_{Vi}F_{iS}I_{SH}. \quad (26)$$

In this equation, E_{VDi} and E_{VSi} are the direct and sky solar radiation gains to i [W], respectively. Further, S_{Rj} is the short-wave radiosity at the surface element j comprising the computational domain [W] by Equation (6).

4.3 Short- and long-wave radiation, MRT in each segment of the thermoregulation model

Absorbed short- and long-wave radiation, S_{seg} and R_{seg} , and the mean radiant temperature (MRT), $T_{prt-seg}$, in each segment of thermoregulation model are calculated using Equations (27), (28), and (29) as follows:

$$R_{seg} = (\sum_{i=1}^{n_{surf}} A_{Vi} \sigma T_{Vprt-i}^4 f_{pi}) / \pi, \quad (27)$$

$$S_{seg} = (\sum_{i=1}^{n_{surf}} \alpha_{seg-i} S_{Vi} f_i) / \pi, \quad (28)$$

$$T_{mrt-seg} = [(R_{seg} + S_{seg}) / \sigma]^{1/4}, \quad (29)$$

where α_{seg-i} is the absorption rate of solar radiation to i including the virtual sphere surface, f_{pi} is the projected area factor between each segment of the model and i . The disposition and direction of the virtual sphere centring the human thermoregulation model is associated with the projected area factor, which enables us to consider the inhomogeneous condition including the effect of a pedestrian's direction on a radiant environment.

The projected area factor (Fanger et al., 1970) has been used as an analysis method of the form factor between the entire human body and the surrounding walls in various studies concerning the radiant environment in indoor and outdoor spaces. In the recent study, we have expanded the method of projected area factor to each part of the body by dividing the body into 17 parts, and quickly developed the databases using a 3D model of the human body (Sato et al., 2014). Figure 4 illustrates an example of f_{pi} on the chest segment. Figure 5 also compares the form factor of each body segment to each surface comprising the computational domain by the method based on projected area factor with the direct calculation with differential areas of the body surface. We can see that the results with the projected area factor agree well with that with the direct calculation. The length of the domain in Fig. 5 is very close to the radius of the virtual sphere; therefore, the results become helpful in estimation of accuracy of the calculation method with the virtual sphere.

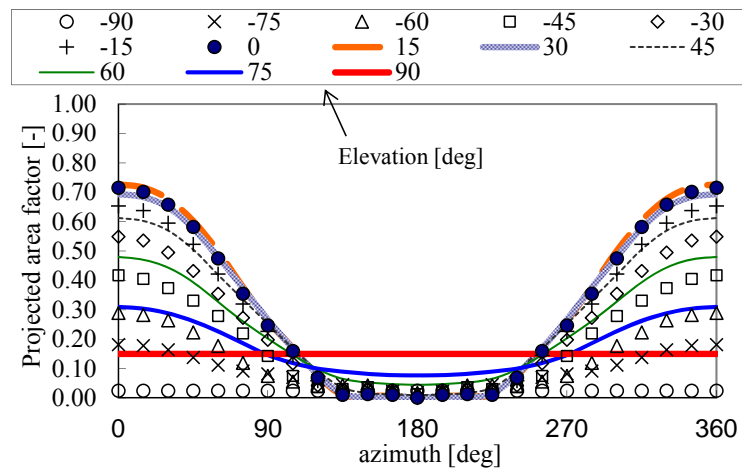

Figure 4. Projected area factor distribution for the chest segment.

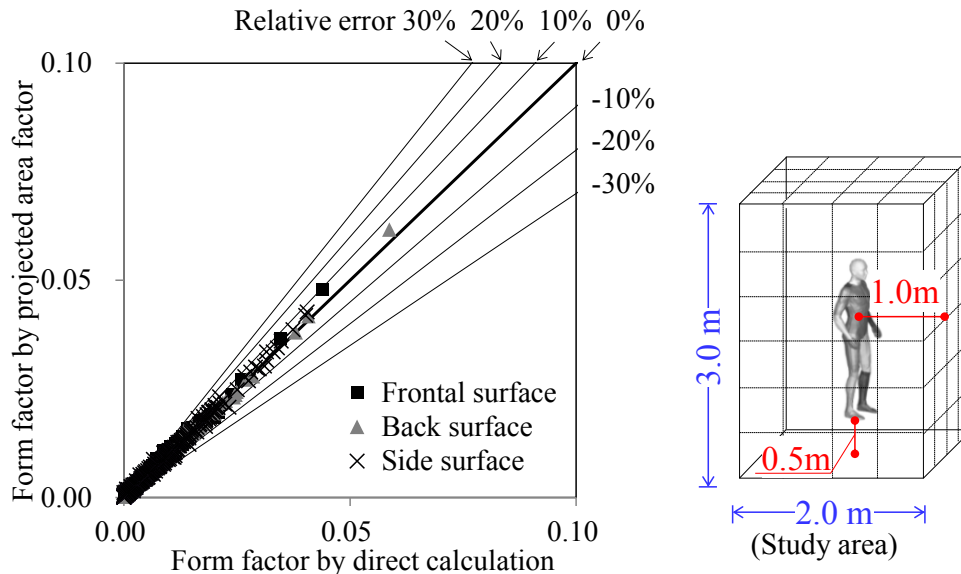

Figure 5. Comparison between the form factor by projected area factor and that by direct calculation.

5 Outline of method for including the inhomogeneous effect of airflow on thermal environments

The inhomogeneity of airflow affects convective heat transfer coefficients and clothing insulations on each segment of the human thermoregulation model.

The convective heat transfer coefficient on each segment of the thermoregulation model includes a relationship between the direction the pedestrian is facing and the airflow, as evaluated either upwind or downstream. The coefficient h_c [W/(m²K)] is determined using Equation (30) as follows:

$$h_c = a \cdot v^b, \tag{30}$$

where v is the relative velocity of airflow [m/s], and a and b are constants on each segment. These constants are determined using the results measured by Oguro et al. (2002). As an example, Table 1 summarizes these constants for a standing pedestrian.

Table 1. Models of convective heat transfer coefficient and clothing insulation for standing pedestrian.

Segment	Convective Heat Transfer Coefficient: $h_c = a \cdot v^b$										Clothing Insulation: $I_{cl} = a \cdot \ln(v) + b$			
	Upwind					Downstream					Upwind		Downstream	
	Nude case h_n		Clothed case h_{cl}		h_{cl}/h_n	Nude case h_n		Clothed case h_{cl}		h_{cl}/h_n	a	b	a	b
	a	b	a	b		a	b	a	b					
Whole Body	9.31	0.60	13.36	0.60	1.42	9.41	0.61	12.38	0.65	1.34	-0.090	0.632	-0.076	0.617
Head	7.14	0.65	24.07	0.68	3.40	6.52	0.69	15.11	0.68	2.32	-0.240	0.642	-0.256	0.735
Chest	7.77	0.59	13.80	0.77	1.91	5.81	0.77	6.90	0.71	1.18	-0.136	0.917	-0.060	0.946
Back	5.86	0.74	7.67	0.63	1.30	7.75	0.57	13.87	0.72	1.93	-0.090	0.861	-0.141	0.820
Pelvic Region	7.60	0.65	11.09	0.60	1.46	8.16	0.61	9.99	0.63	1.24	-0.114	1.057	-0.102	0.970
L-Shoulder	10.04	0.59	11.86	0.63	1.19	10.25	0.62	10.31	0.72	1.04	-0.097	0.566	-0.064	0.554
L-Arm	11.40	0.60	15.46	0.50	1.33	11.37	0.59	14.26	0.69	1.30	-0.096	0.579	-0.074	0.538
L-Hand	16.57	0.59	16.57	0.59	1.00	15.25	0.54	15.25	0.54	1.00				
R-Shoulder	9.51	0.62	10.62	0.70	1.14	8.99	0.63	10.17	0.74	1.18	-0.101	0.563	-0.057	0.529
R-Arm	11.79	0.57	14.61	0.57	1.25	11.05	0.61	13.78	0.66	1.27	-0.096	0.614	-0.079	0.576
R-Hand	14.04	0.57	14.04	0.57	1.00	16.66	0.52	16.66	0.52	1.00				
L-Thigh	8.94	0.58	11.02	0.53	1.23	9.19	0.63	11.80	0.57	1.28	-0.072	0.480	-0.016	0.406
L-Leg	11.70	0.54	14.80	0.52	1.26	12.42	0.55	17.32	0.64	1.42	-0.049	0.512	-0.042	0.516
L-Foot	10.59	0.53	10.59	0.53	1.00	10.87	0.60	10.87	0.60	1.00	-0.037	0.647	-0.057	0.643
R-Thigh	8.95	0.60	9.47	0.50	1.05	8.99	0.63	10.02	0.62	1.12	-0.055	0.419	-0.038	0.415
R-Leg	12.03	0.57	14.24	0.53	1.18	12.54	0.56	17.77	0.65	1.44	-0.057	0.503	-0.041	0.524
R-Foot	10.77	0.51	10.77	0.51	1.00	10.91	0.58	10.91	0.58	1.00	-0.038	0.633	-0.059	0.660

* v : velocity of airflow [m/s]

Clothing insulations on each segment vary with the thickness of the air layer between the clothing and the skin. The relationship between the pedestrian's facing direction and the airflow direction also affects the distributions of air layer thickness. Therefore, the following equation that includes the effect of the relationship on the clothing insulation [*clo*] on each segment is used in this study:

$$I_{cl} = a \cdot \ln v + b. \quad (31)$$

Table 1 also lists the values of the constants *a* and *b* for a standing pedestrian.

6 Outline of multi-node human thermoregulation model

The human thermoregulation model enables us to predict the thermal physiological mechanism, which regulates heat production and heat loss through vasodilation, vasoconstriction, shivering, and sweating, in order to maintain the core temperature within normal limits. Recently, a research group led by Tanabe in Waseda University in Japan developed four multi-node human thermoregulation models known as “65MN” (Tanabe et al, 2002), “COM” (Tanabe et al., 2006), “JOS” (Sato et al., 2003), and “JOS-2” (Kobayashi and Tanabe, 2013).

The calculation method proposed in this paper allows us to adopt one of these human thermoregulation models, and to replace it according to our wishes. In the analysis at the latter part of this paper, we use the JOS as the thermoregulation model since our code of the JOS-2 is now under constructing. Hence, we will change to the JOS-2 when it is complete.

The JOS model is based on Stolwijk's well-known model (Stolwijk, J.A.J., 1971). The body surface and weight for a standard body are set to 1.87 m² and 74.43 kg respectively. The entire body is divided into 17 body segments (head, neck, chest, back, pelvis, left shoulder, left arm, left hand, right shoulder, right arm, right hand, left thigh, left leg, left foot, right thigh, right leg, and right foot). All individual body segments consist of a core layer, a skin layer, an artery blood pool, a vein blood pool, and a superficial vein blood pool. Additionally, the JOS has arteriovenous anastomoses (AVA) that connect arteries and superficial veins without exchanging heat with any tissues in each segment of the hands and feet. For the details of the JOS, refer to the above mentioned literature (Sato et al., 2003, and Kobayashi and Tanabe, 2013).

7 Outline of convection calculation

In this calculation method, we use various types of the turbulent model of CFD analysis. In the present stage of the development of the calculation method, the standard *k-ε* model or the revised one allow us to use the practical analysis, and we have introduced the following two improvements to the standard model: (1) Inclusion of the effect of buoyancy on the evaluation of the turbulent-flow heat flux, such as the WET model (Launder, 1998), and (2) Inclusion of the function that controls excessive production of the turbulent-flow energy *k* on the building windward side, such as the modified Kato-Launder model (Kato and Launder, 1993). In this paper, we omit the explanation of details of this calculation because we mainly focus on the effect of inhomogeneous radiant condition at the analysis described below, then do not carry out the convection calculation in the present analysis. We will describe it when we

investigate the effect of inhomogeneity of wind condition on the thermal comfort for the pedestrian using this calculation method. For the details of the CFD analysis method, refer to Chen et al. (2004).

8 Outline of analysis

In this section, we investigate the effects of the weather on an inhomogeneity of a radiant environment in an outdoor space during the summer season in order to evaluate availability of the proposed method in this paper.

8.1 Study area

Figure 6 illustrates the computational domain in this analysis. It is assumed that a pedestrian stands still for long periods in the domain where no effects of complex terrain and building location are included. This is because we obtain simple calculation results for evaluating the only effect of weather conditions on inhomogeneity on a radiant environment for a pedestrian. The shape of the pedestrian is also illustrated in Fig. 6. We use a numerical shape model of a male human body, which was estimated by Ito et al., 2006. Table 2 summarizes the surface area for each segment of the human body. In this analysis, it is assumed that the clothes for the pedestrian are an office worker style during the summer season, or a white short-sleeved shirt and dark-blue trousers. The values of albedo, or reflectance of short wave radiation, for the shirt, the trousers, and the skin for the pedestrian are set to 0.6, 0.2, and 0.4, respectively. The ground in the domain is covered with concrete.

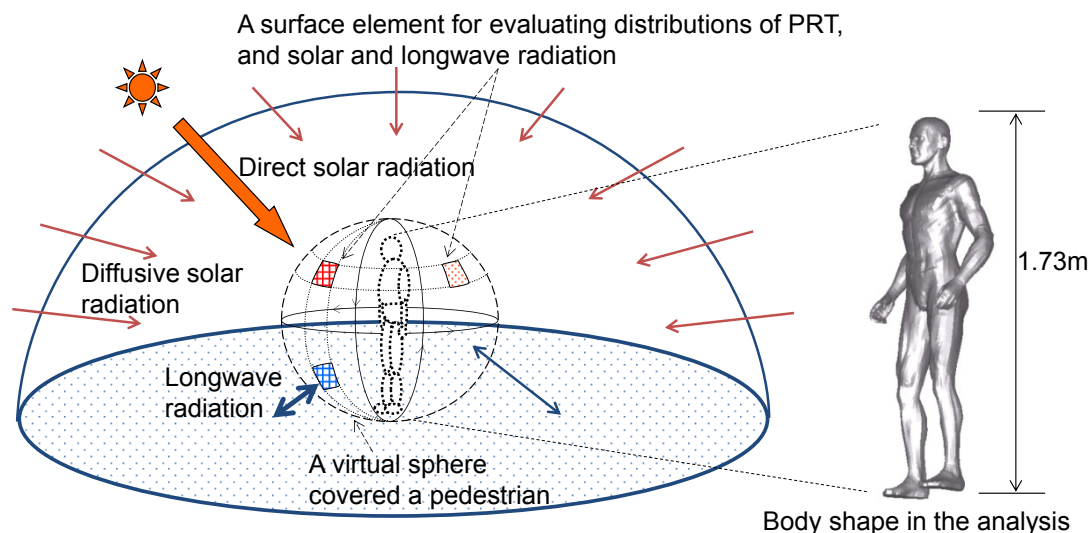

Figure 6. Computational domain in the present analysis.

Table 2. Surface area of each segment of the multi-node thermoregulation model.

No	Segment	Standard body for JOS		Surface area of each segment for the human body in the analysis [m ²]
		Surface area[m ²]	Weight [kg]	
1	Head	0.110	3.180	0.119
2	Neck	0.029	0.840	0.029
3	Chest	0.175	12.400	0.168
4	Back	0.161	11.030	0.149
5	Pelvis	0.221	17.570	0.201
6	L Shldr	0.096	2.160	0.075
7	L Arm	0.063	1.370	0.071
8	L Hand	0.050	0.340	0.038
9	R Shldr	0.096	2.160	0.075
10	R Arm	0.063	1.370	0.071
11	R Hand	0.050	0.340	0.038
12	L Thigh	0.209	7.010	0.192
13	L Leg	0.112	3.340	0.112
14	L Foot	0.056	0.480	0.052
15	R Thigh	0.209	7.010	0.191
16	R Leg	0.112	3.340	0.113
17	R Foot	0.056	0.480	0.054
	WholeBody	1.868	74.420	1.745

8.2 Computational conditions for the multi-node human thermoregulation model

In this analysis, we used the JOS model as a multi-node human thermoregulation model in order to evaluate the thermal comfort of the pedestrian. As shown in Table 2, the surface area of each body segment for the human body in the present analysis is different from the standard body shape. The heat characteristics of the human body depend on physical properties, such as posture, gender, and age, and other individual factors. Hence, in the present analysis, it is necessary to incorporate the effects of the surface area on the heat characteristics into the calculation model. The JOS enables us to include these effects on values of coefficients concerning thermoregulation mechanisms. In this study, we set these values from the literature of the JOS-2 model (Kobayashi et al., 2013).

8.3 Meteorological condition

We investigate the following two different weather conditions cases in this analysis: a scorching hot day (case 1), and a cloudy day (case 2). Meteorological data measured at the Japan Meteorological Agency in Tokyo are used in this study, and target days for case 1 and case 2 are set to 23 July and 14 August in 2010, respectively. The analysis starts at 6:00 on a day before the target day, and a time integration of 48 hours is performed using the meteorological data. The thermal environment for the pedestrian is evaluated using the results obtained at 15:00 on each target day. Figure 7 illustrates the time variations of the global solar radiation and the air temperature during the period of the computation, as an example of the meteorological data. Table 3 also summarizes the meteorological conditions at the target time for the evaluation on the outdoor thermal comfort for the pedestrian. In the present analysis, the orientation of the pedestrian is set to a south direction. Hence, it is assumed that the solar radiation irradiates from a right-hand side direction for the pedestrian.

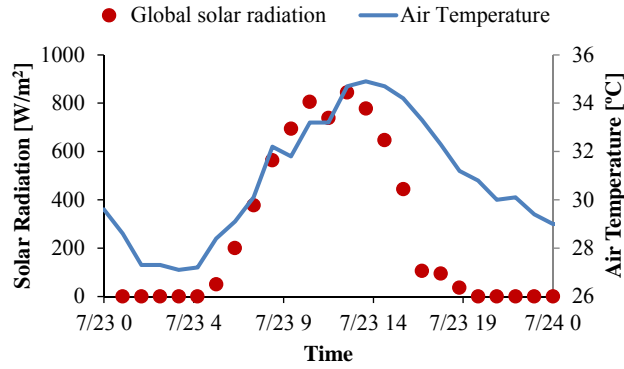

(1) case 1 (a scorching hot day, 2010/07/23)

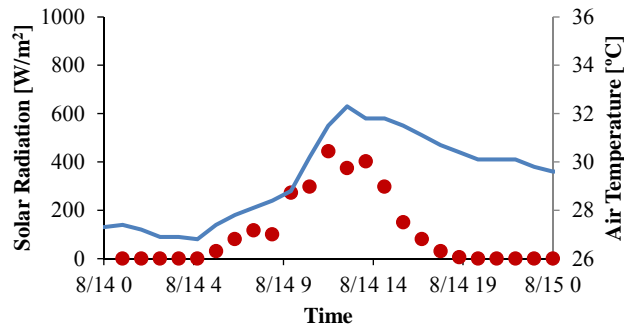

(2) case 2 (a cloudy day, 2010/08/14)

Figure 7. Time variations of global solar radiation and air temperature.

Table 3. Meteorological condition at the target time for this analysis

case	Case 1	Case 2
Target time	15:00 on 23 rd July in 2010	15:00 on 14 th August in 2010
Weather	A scorching hot day	A cloudy day
Global solar radiation [W/m ²]	647.2	297.2
Sun's altitude [deg]	45.1	41.7
Sun's azimuth [deg]	82.9 (nearly W)	76.6 (nearly WSW)
Air temperature [°C]	34.7	31.8
Relative humidity [%]	48	62
Wind direction and velocity	SSE, 1.2m/s	SSW, 1.6m/s
Orientation of the pedestrian	0.0 (South)	

8.4 Computational conditions for the metabolic rate, convective heat transfer coefficients, and clothing insulation

A value of the metabolic rate and a duration time of exposure are set to 1.2 Met and one hour, respectively. Convective heat transfer coefficients and clothing insulations for each body segment are calculated using the function of wind velocity, which is proposed by Oguro et al. (2001), as mentioned in the previous section.

9 Results and discussion

9.1 MRT

Firstly, we validate accuracy of the evaluation of calculation results of MRT using the virtual sphere model, which is proposed in the present paper. Figure 8 illustrates the time variations of MRT for an entire body. Figure 9 shows a comparison of the results

of MRT using the virtual sphere (V. S.) model with the existing prismatic human body (P. B.) model (Nakamura, 1987). The values in these figures are calculated on the assumption that the short wave radiation incident to the surface of the human body is perfectly absorbed in order to eliminate the effect of colours of the clothing and the skin of the human body. In the weak inhomogeneity of radiant conditions, such as the whole day of cloudy condition and the night time on a sunny day, we can see a small difference in the results between V.S. and P.B. The results reflect the fact that the method using V.S. enables us to obtain the calculation results that have the equivalent accuracy to the results using P.B. Additionally, in the strong inhomogeneous radiant condition, or the daytime in the sunny day, we can see the MRT from V.S. is approximately 5 °C larger than from P.B., as shown in Fig. 9. This is caused by the fact that the V.S. model can predict the inhomogeneous radiant condition accurately. Hence, from the above estimation, it has been found that the V.S. model has the adequate accuracy for the radiant computation.

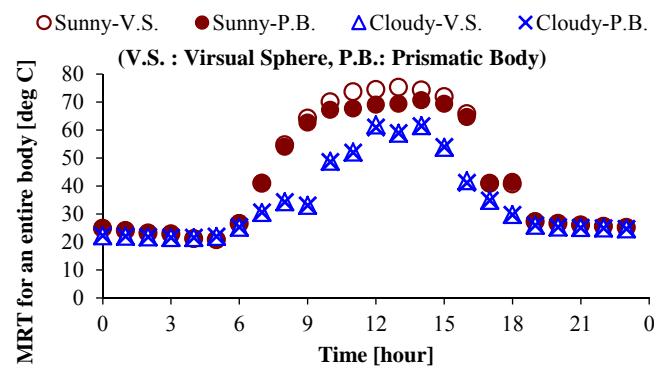

Figure 8. Time variations of MRT for a whole body.

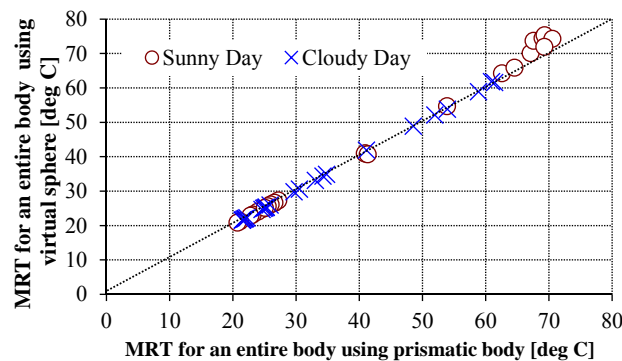

Figure 9. Comparison of MRT values for the whole body using the different calculation method.

Figure 10 illustrates the distribution of MRT on each body segment for the pedestrian. Both values in case 1–2 and case 2–2 are calculated on the same assumption in Fig. 8 and Fig. 9. Alternatively, in case 1–1 and case 2–1, it is assumed that the pedestrian wears the usual clothing style for a man in an office building during summer. As abovementioned, the orientation of the pedestrian is set to a south direction, then a solar radiation irradiates from a right-hand side direction for the pedestrian. Hence, the values in case 1–2 range from approximately 65 °C to approximately 85 °C, and the values on the right shoulder, the right arm, and the right hand are significantly high. While in case 2–2, or a cloudy condition, MRT on each body segment range from approximately 52–55 °C, therefore the difference is quite small. We also see that values in case 1–1 and case 2–1 are lower than those in case 1–2 and case 2–2, respectively, and there are large differences of MRT on the upper body segments.

This difference is caused by considering effects of colours of a white short-sleeved shirt and skin on reflectance for the short-wave radiation.

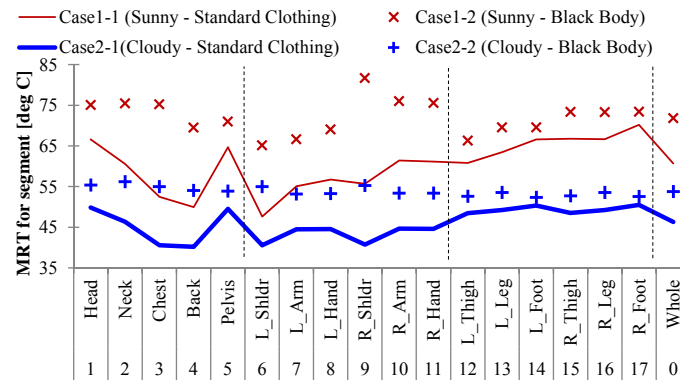

Figure 10. Distribution of MRT on each body segment for the pedestrian

9.2 Distribution of each node temperature

Figure 11 illustrates the distributions of mean temperature of each node in body segments. In case 1-1, or a scorching hot day, skin temperatures on the right-hand side segments are higher than those on the opposite side segments since the solar radiation irradiates to the right-hand side direction for the pedestrian. We also see a large difference of each node temperature between both cases, especially on the four limbs. This is caused by the function of the AVA on the thermal physiology in the heavy hot environment, such as case 1-1. As mentioned above, the AVA models are incorporated into the JOS model, and are located in each segment of the hands and feet. The openness percentage of the AVA, O_{AVA} varies with the thermal environment in order to control the blood flow to the surface vein blood pool using the following equations:

$$O_{AVA} = 0.265(T_{sk} - 34.0) + 0.953(T_{cr} - 36.8) + 0.9126, \quad (32)$$

$$O_{AVA} = 0.265(T_{sk} - 35.4) + 0.953(T_{cr} - 37.0) + 0.9126. \quad (33)$$

In these equations, the symbols T_{sk} and T_{cr} also denote the skin and the core temperature in each segment of the hands and feet. If the value of O_{AVA} is larger than 1 or is smaller than 0, O_{AVA} is set to 1, and 0 respectively. Figure 12 illustrates the time variations of the mean openness percentage of the AVA, which is the average between the four limbs. In case 1-1 (a sunny condition), the value of O_{AVA} reaches the maximum value at 10 minutes after the beginning of the calculation. This is because a bloodstream in each limb segment increases with the hot thermal environment in order to transfer an inner heat from the core to the skin smoothly. The temperature of the blood flow from the core to skin is higher than the skin temperature. Hence, the skin temperature rises with the increase of the blood flow in four limb segments, as shown in Fig. 11. On the other hand, the value of O_{AVA} on a cloudy day falls below 0.4 at the end of the calculation, and the amount of the blood flow in the limb segments is not as large as that in case 1-1. Hence, it has been thought that the temperatures in the four limbs resulted in the low value in this analysis.

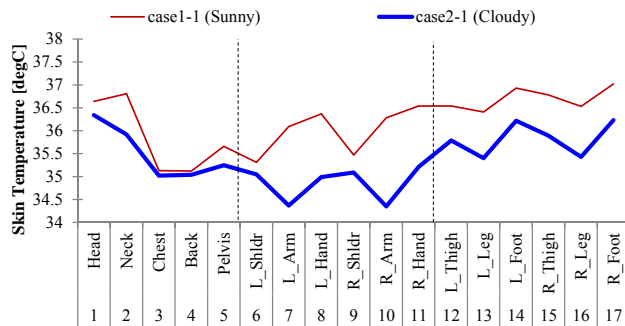

(1) Skin temperature

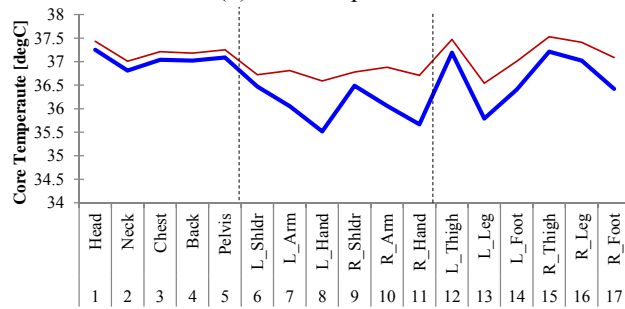

(2) Core temperature

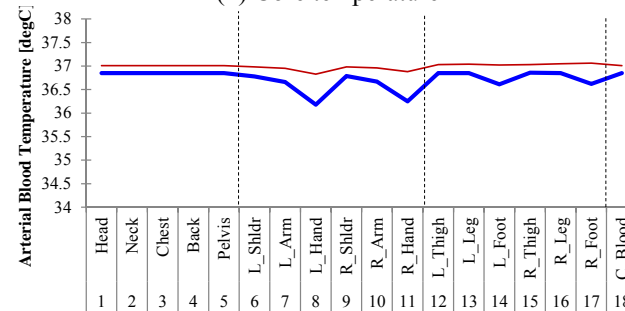

(3) Arterial blood pool temperature

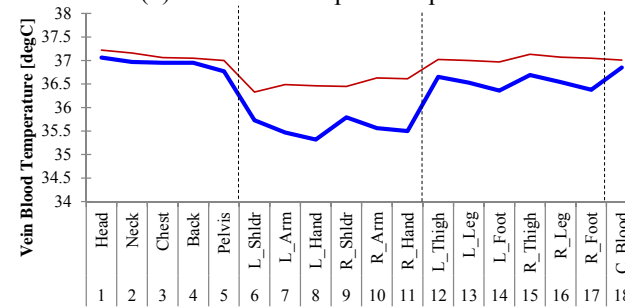

(4) Vein blood pool temperature

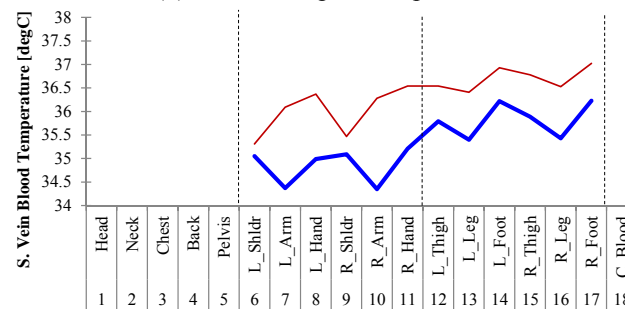

(5) Superficial vein blood pool temperature

Figure 11. Distribution of MRT on each body segment for the pedestrian

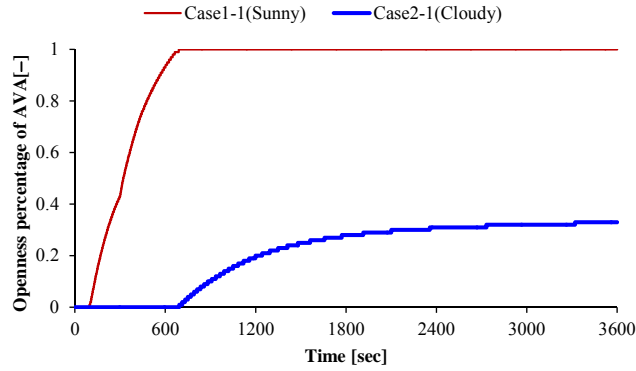

Figure 12. Time variations of mean openness percentage of the AVA

9.3 Mean skin temperature and mean core temperature for the entire body

Figure 13 shows the time variations of mean skin temperature for the entire body during the exposure time. The value in case 1-1 at the end of the calculation is approximately 36.1 °C, and that in case 2-1 is approximately 35.4°C. The value in case 1-1 is 0.7°C larger than that in case 2-1.

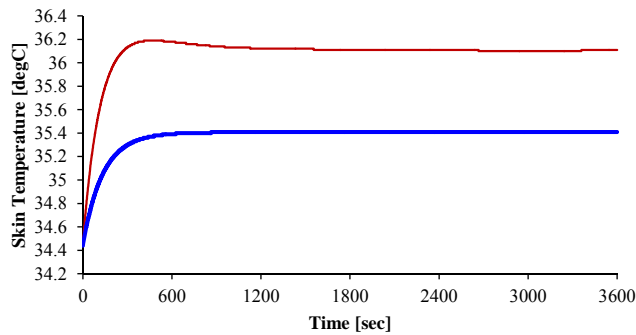

Figure 13. Time variations of mean skin temperature for the entire body.

The time variations of core temperature for the entire body are illustrated in Fig. 14. The values in both cases gradually increase with the exposure time. The value in case 1-1 at the end of the calculation is approximately 37.3 °C, and that in case 2-1 is approximately 37.0°C. The value in case 1-1 is 0.3°C larger than that in case 2-1.

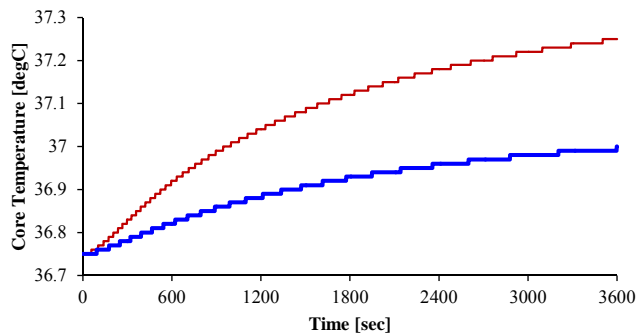

Figure 14. Time variations of mean core temperature for the entire body.

9.4 Skin wettedness and cumulative sum of regulated sweat

Figure 15 illustrates the result on skin wittedness using the thermoregulation model. The value in case 1-1 at the end of the calculation is approximately 47%, and that in case 2-1 is approximately 27%.

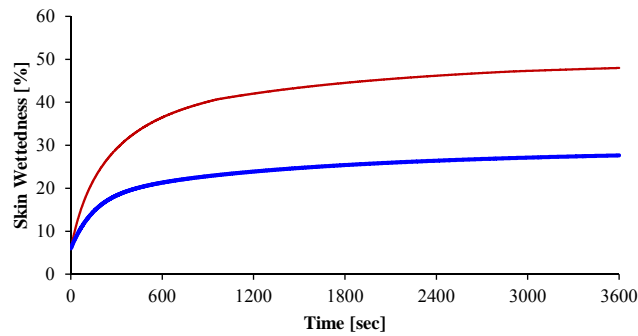

Figure 15. Time variations of mean skin wettedness for the entire body.

The time variations of the cumulative sum of the regulated sweat are shown in Fig. 16. The value in case 1–1 reached 174 g at the end of the calculation, whereas the value in case 2–1 reached 79 g. It is well known that the human body sweats in order to release additional heat to its surroundings. Hence, we can regard sweating as the result of an inner effort by the human body. It has been estimated that the intensity of the thermal load in case 2–1 is equivalent to approximately 0.45 times that in case 1–1.

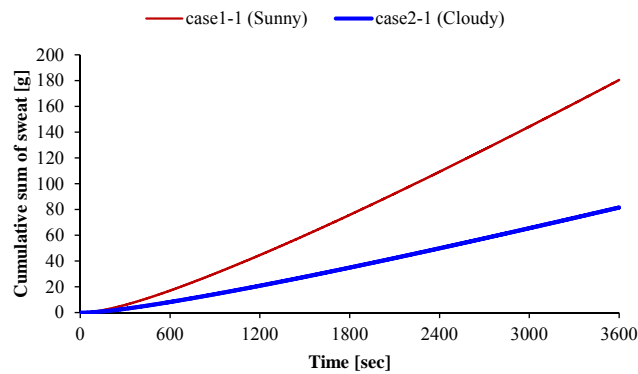

Figure 16. Time variations of cumulative sum of regulated sweat for the pedestrian.

10 Concluding remarks

- (1) In this paper, we outlined a new calculation method for evaluating the inhomogeneous outdoor thermal environment by incorporating a multi-node human thermoregulation model into the simulation method based on CFD analysis of the outdoor thermal environment.
- (2) In the latter part of this paper, we investigated the effects of weather on the inhomogeneity of the radiant environment and the thermal comfort for pedestrians using the proposed calculation method. In this analysis, two different weather condition cases were considered: (1) a scorching hot day and (2) a cloudy day. From the results of the analysis, it has been estimated that the intensity of the thermal load on the sunny day is approximately 2.2 times stronger than the intensity on the cloudy day.
- (3) Through the investigation of the analysis, it has also been found that the proposed method in this study is a powerful tool for the evaluation of the inhomogeneity of the thermal comfort in the outdoor space. A future direction of this study will be to evaluate the effects of the inhomogeneity of wind environment on the thermal

comfort for the pedestrian in the outdoor space and to apply the calculation method to more practical assessments on thermal comfort in outdoor space.

Acknowledgement

This study was partially funded by the Grant-in-Aid for Young Scientists (B) (no.17760466, 19760403, 25820279).

References

- Bouyer, J., Vinet, J., Delpech, P., and Carre, S. 2007. Thermal comfort assessment in semi-outdoor environments: Application to comfort study in stadia. *J. Wind Eng. Ind. Aerodyn.* 95, pp 963-976.
- Bruse, M., 1999. Modelling and Strategies for improved urban climates. *Proceedings International Conference on Urban Climatology & International Congress of Biometeorology*, Sydney, Australia, 8-12 November 1999, <http://www.envi-met.com/scidocs.htm>.
- Bruse, M., 2009. Analysing human outdoor thermal comfort and open space usage with the Multi-Agent System BOT world. *Seventh International Conference on Urban Climate ICUC-7*, Yokohama, Japan, 29 June – 3 July 2009, B14-3.
- Chen, H., Ooka, R., Harayama, K., Kato, S., Li, X., 2004. Study on outdoor thermal environment of apartment block in Shenzhen, China with coupled simulation of convection, radiation and conduction. *Energy and Buildings*, 36, pp 1247-1258.
- Fanger, P. O., Angelius, O., Kjerulf-Jensen, P., 1970. Radiation data for the human body, *ASHRAE Transactions*, 76, pp 338-373.
- Gagge, A.P., Stolwijk, J.A.J., and Nishi, Y., 1986. A standard predictive index of human response to the thermal environment. *ASHARE Transactions*, Vol.92, part 1, pp 709-731.
- Ito, K., Mukai, Y., Murakami, T., Yoshimura, J., and Hayashi T., 2008. Development of the Virtual Manikins and a Grid Library for CFD Analysis. *YSRIM 2008, Proc. of the Yellow Sea Rim International Exchange Meeting on Building Environment and Energy 2008*, Busan, Korea, 21-23 January 2008, pp 175-182.
- Kato, M., Launder, B. E., 1993. The modelling of turbulent flow around stationary and vibrating square cylinders. *Prep. of the 9th Symposium on Turbulent Shear Flow*, Kyoto, Japan, 16-18 August 1993, pp 1-6.
- Kobayashi, M., and Tanabe, S., 2013. Development of JOS-2 human thermoregulation model with detailed vascular system. *Building and Environment*, 66, pp 1-10.
- Launder, B. E., 1988. On the computation of convective heat transfer in complex turbulent flows. *Trans. ASME, J. Heat Transfer*, 110, pp 1112-1128.
- Mayer, H., 2008. KLIMES - a joint research project on human thermal comfort in cities. *Ber. Meteor. Inst. Univ. Freiburg*, No. 17, pp 101-117.
- Mayer, H., and Höpfe, 1987. Thermal comfort of man in different urban environments. *Theor. Appl. Climatol.*, 38, pp 43-49.

Mellor G. L. and Yamada, T. 1975. A simulation of the Wangara atmospheric boundary layer data. *J. Atmos. Sci.* 32, pp 2309–2329.

Nakamura, Y., 1987. Expression method of the radiant field on a human body in buildings and urban spaces. *J. Archit. Plann. Environ. Eng., AIJ*, 376, pp 29-35 (in Japanese with English abstract).

Oguro, M., Arens, E., Zhang, H., Tsuzuki, K., and Katayama, T., 2001. Measurement of projected area factors for thermal radiation analysis on each part of the human body. *J. Archit. Plann. Environ. Eng., AIJ*, 547, pp 17-25.

Oguro, M., Arens, de Dear, R., E., Zhang, H., and Katayama, T., 2002, Convective heat transfer coefficients and clothing insulations for parts of the clothed human body under airflow conditions, *J. Archit. Plann. Environ. Eng., AIJ*, 561, pp 21-29.

Oomori, T., Taniguchi, H., Kudo, K., 1990. Monte Carlo simulation of indoor radiant environment. *Int. J. Numerical Methods in Engineering*, 30(4), pp 615-627

Sato, T., Oguro, M., and Yoshida, S., 2014. Evaluation of radiative heat transfer to human body in indoor space using projected area factors for each part of human body, Part 1 Estimation of projected area factors using human shape model and evaluation of angle factors for closely located walls. *Transactions of the society of heating, air-conditioning, and sanitary engineers of Japan*, 202, pp 1-10 (in Japanese with English abstract).

Sato, T., Xu, L., Tanabe, S., 2003. Development of human thermoregulation model JOS applicable to different types of human body. *Proceedings of Healthy Buildings 2003*, Singapore, 7-11 December 2003, Vol. 1, pp 828-834.

Stolwijk, JAJ., 1971. A mathematical model of physiological temperature regulation in man, *NASA contractor report-1885*.

Tanabe, S., Kobayashi, K., Nakano, J., Ozeki Y., and Konishi, M., 2002. Evaluation of thermal comfort using combined multi-node thermoregulation (65MN) and radiation models and computational fluid dynamics (CFD). *Energy and Buildings*, 34, pp 637-646.

Tanabe, S., Kobayashi, K., and Ogawa, K., 2006. Development of numerical thermoregulation model COM for evaluation of thermal environment. *J. Environ. Eng., AIJ*, 599, pp 31-38 (in Japanese with English abstract).

Yoshida, S., Shuzo Murakami, Ryoza Ooka, Akashi Mochida, Yoshihide Tominaga, 2000. CFD prediction of thermal comfort in microscale wind climate. *Abstracts of papers presented at the 3rd International Symposium on Computational Wind Engineering*, Birmingham, U.K., 4-7 September 2000, pp 27-30.

Yoshida, S., Ooka, R., Mochida, A., Murakami, S. and Tominaga, Y., 2006. Development of three dimensional plant canopy model for numerical simulation of outdoor thermal environment. *the 6th International Conference on Urban Climate*, Göteborg, Sweden, 12-16 June 2006, pp 513-516.

Yoshida, S., Oguro, M., 2009. Investigation on a method incorporating inhomogeneous environmental conditions into CFD analysis of outdoor thermal environment coupled with multifractional human thermoregulation model. *the 7th International Conference on Urban Climate*, Yokohama, Japan, 29 June – 3 July 2009, B4.

The impact of the Urban Heat Island in the energy consumption and overheating of domestic buildings in London

Juan J Lafuente and Dr Luisa Brotas

Low Energy Architecture Research Unit, Sir John Cass Faculty of Art, Architecture and
Design, London Metropolitan University, London, UK
jjl0039@my.londonmet.ac.uk, l.brotas@londonmet.ac.uk

Abstract

Considering the adaptive comfort approach, this article estimates if interior conditions in London's naturally ventilated residential stock are comfortable under the Urban Heat Island (UHI) effect and predicts if climate change will further affect comfort levels. A discussion whether the UHI is currently saving or aggravating energy consumption in buildings is presented. The affection that climate change may have in the energy performance of buildings in the future is also estimated. The most representative household profiles in London have been modelled and simulated. Weather files for a few locations in the city have been used to estimate energy consumption and interior comfort conditions. Future conditions have been estimated using climate change predictions based in UKCP09. Results show that the UHI is currently saving energy in London and the interior conditions are comfortable for the average households. Future climate change estimations show that occupants will adapt to changing conditions and archetypes' resilience can avoid overheating until 2080 only relying in natural ventilation. Critical occupation profiles more prone to suffer overheating have also been simulated.

Keywords: Urban Heat Island · Adaptive Thermal Comfort · Energy efficiency · Overheating · Climate Change

1 Introduction

The Urban Heat Island (UHI) is the common denomination given to a local change in the climate of urban landscapes. Its main characteristic is that the centre of urban areas is normally significantly warmer than the surrounding countryside. The Urban Heat Island is considered a hazardous and costly event to be avoided. According to on-going research and current policies, higher temperatures in the city centre cause overheating and serious comfort and health problems in the population which lead to higher mortality rates (WHO, 2008; GLA, 2006). Besides, higher temperatures in the city centre also cause higher energy consumption in buildings because air conditioning energy demand is always proportionally higher than the potential savings in heating (Kolokotroni et al, 2006).

However, the UHI is a permanent change in the local climate and according to the adaptive comfort approach people can successfully adapt to their permanent local conditions in free-running buildings (Humphreys, 1978). Temporary and acute temperature changes – like heat or cold waves – displace temperature out of the comfortable range and could affect population's health. However, heat waves are not caused by the UHI. Besides, many buildings in London – many of them residential – do not enjoy air conditioning and therefore, the UHI might also be saving energy in winter.

Whereas at present conditions most of residential buildings in London are comfortable in summer, due to global warming and expected higher temperatures, buildings may not be kept at acceptable comfort levels without active cooling systems.

2 Objectives

Thermal comfort

The main risk of the UHI for the naturally ventilated residential sector is overheating, which can cause discomfort and in extreme cases affect health.

Obj 1. Evaluation of the interior conditions of the most common naturally ventilated households in London to verify if they can be currently kept within comfortable levels. Building simulation software and weather files surveyed in different locations of London's UHI have been used. Overheating conditions have been set following the adaptive comfort criteria as defined in CIBSE's TM 52 (2013).

Energy performance

The UHI effect has a direct influence in the heating loads of the naturally ventilated residential stock in winter.

Obj 2. Estimation of the potential annual energy savings caused by the UHI effect.

Climate change

Climate change is expected to vary the UHI and its influence in London's residential stock.

Obj 3. UKCIP09 climate change projections for the UK have been used in the same models to predict if homes will be at risk of overheating in 2020, 2050 and 2080 and if the energy performance of buildings affected by the UHI would vary following global warming.

3 Methodology

The typologies, thermal characteristics and occupancy profiles are consistent in every present and future scenario to maintain consistency amongst results.

Three archetypes and two occupancy profiles have been defined. Data from the latest Census (ONS, 2011) define the two most common households in London: a 2-bedroom apartment occupied by two people and a 3-bedroom terraced house occupied by three people. The standard characteristics of these buildings have been adopted from the baseline typologies developed by Zero Carbon Hub in the Task Group recommendations to define zero carbon homes (ZCH, 2009). These typologies are built following current building regulations standards, which are not completely representative of London's residential stock. However, available retrofitting strategies can upgrade most of the existing stock to current building standards. Moreover, the simulations model scenarios until 2080 and therefore, adopting current building characteristics is realistic.

The two most common archetypes are mid-terraced house and mid-flat. However, recent studies about the UHI and overheating in the residential sector concluded that flats can be more problematic, in particular due to their position within the building rather than their location within the UHI (Mavrogianni et al, 2012). Following these results, the flat archetype was simulated in mid and top floors of a building.

Two different occupancy profiles were developed: the first one – *average occupancy* – assumes that occupants work or study following usual working hours and therefore, the typologies are not occupied during the daytime. The second profile – *continuous occupancy* –

assumes that occupants work from home or are elderly people. These profiles are assumed more vulnerable to overheating, as people are likely to stay longer hours at home during the hottest part of the day. This second profile assumes that every thermal zone defined in the model is continuously occupied by at least one person. Further details on schedules, internal loads, services modelled, building construction details and overall assumptions can be found elsewhere (Lafuente, 2013).

Case studies were simulated with EnergyPlus software. Simulations for present scenarios used weather files from two datasets: three locations – Uxbridge, British Museum and Whitechapel – were provided from the 1999/2000 Survey of London's UHI (Watkins et al, 2002); and other four – Islington, Heathrow, St Albans and Welwyn – are available from the Prometheus Project (University of Exeter, 2011).

This last dataset is based in the output of UKCP09 and provides present and future probabilistic climate change projections in the same four locations for 2010, 2030, 2050 and 2080. Data from both datasets were required because the first one provides real records in several London inner locations, but future projections were not developed. The second database provides present and future projections, but only one of the available locations is in central London. The combination of data from two different sources might lead to slight inaccuracies in absolute results. However, the trends that results define do not vary significantly. The quality of both sources is considered to be good enough to minimize these differences.

Whole year simulations were run in EnergyPlus at different locations to obtain the energy consumption per square meter of each typology and occupancy profiles. Results are presented in terms of relative energy performance of each scenario against the base case model, to be presented later. EnergyPlus output also provided temperature data according to the adaptive comfort approach defined at BS EN 15251 (BSI, 2007).

To predict overheating, the three criteria defined by the TM52 (CIBSE, 2013) – also based in the adaptive comfort approach – were verified in the locations most affected by the UHI (central London) under both occupancy profiles. These three criteria have been defined to provide a quantitative answer to different modes in which overheating can be experienced:

Criterion 1: Limit of the number of hours between May and September that the operative temperature can exceed the threshold comfort temperature. The limit is set to 3% of the occupied time.

Criterion 2: Severity within any one day. This is a function of both temperature rise and duration of the overheating periods defining the daily weighted exceedance.

Criterion 3: Upper limit temperature. Operative temperature should never exceed the threshold comfort temperature in more than four degrees.

A building is considered to be overheated if it does not comply with two of these three criteria.

4 Results

4.1 Present

From the seven available locations, St Albans is the least affected by the UHI, so it has been used as the baseline for energy consumption calculations. Figures 1 (Mid Flat) and 2 (Top Flat) display the relative annual energy consumption of each location for both occupancy

profiles compared with St Albans. The percentages are calculated dividing the annual energy consumption per square meter of each location by the energy consumption in St Albans. The results obtained for the mid-terraced house and the mid-flat are very similar. Detailed results and graphs can be consulted elsewhere (Lafuente, 2013).

4.1.1 Energy consumption

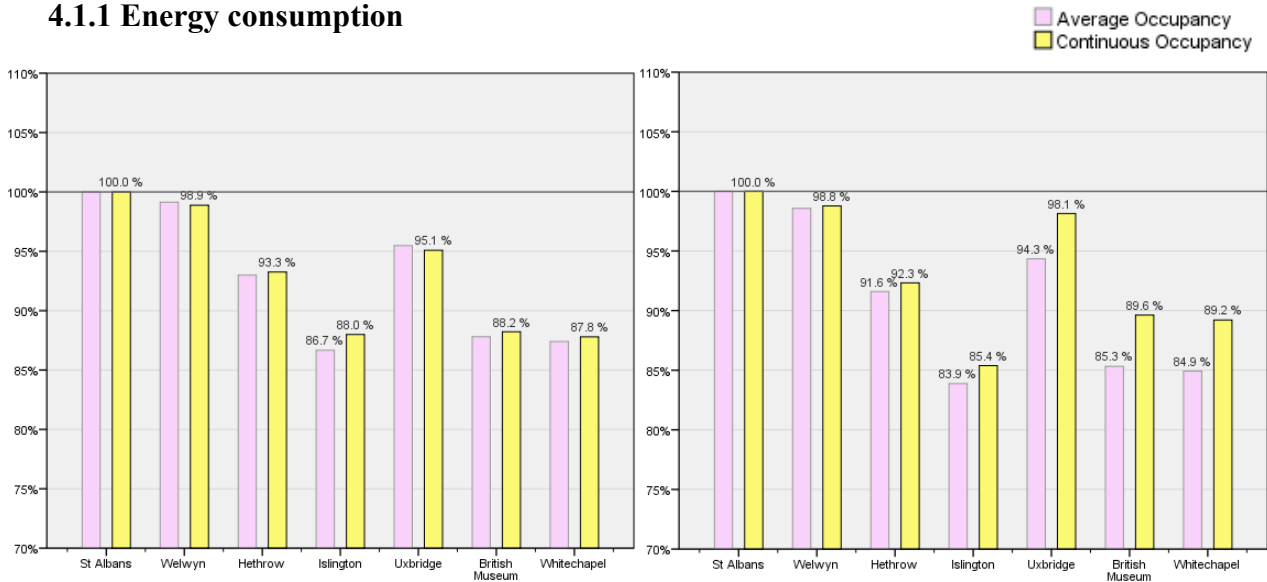

Figure 1. Mid-Flat relative annual energy consumption of each available location compared with St Albans.

Figure 2. Top-Flat relative annual energy consumption of each available location compared with St Albans.

Mid Flats in central London are currently using around 13% less energy than the same typology in St Albans. Top flats use between 10 and 16% less energy depending on the occupancy profiles.

4.1.1 Risk of overheating

According to TM52 (CIBSE, 2013), a space will not suffer from overheating if satisfies any two of the three criteria defined in the publication. Table 1 shows that the criteria to assess overheating is satisfied at all the studied zones in central London (British Museum, Whitechapel and Islington). It is assumed that if these locations comply with the required criteria, the rest of the locations will not be at risk of overheating as the UHI intensity is much lower.

These results show that even though current building standards can prevent buildings from overheating, under the continuous occupancy profile there were periods where the temperatures were outside the comfort range.

The three locations follow similar patterns. However, Islington followed by Whitechapel are more sensitive to the UHI effect. The most sensitive typology due to its higher exposure is the top flat.

Table 1. Comfort compliance at present according to TM52 in central locations.

BRITISH MUSEUM 1999/2000			Mid Terrace				Mid Flat				Top Flat			
			Average Occupancy		Continuous Occupancy		Average Occupancy		Continuous Occupancy		Average Occupancy		Continuous Occupancy	
			Z1 GF	Z2 1F	Z1 GF	Z2 1F	1a Kitchen	1b Bedrooms	1a Kitchen	1b Bedrooms	1a Kitchen	1b Bedrooms	1a Kitchen	1b Bedrooms
CRITERION 1	Overheating if Result >3%	[Energy +]	0.00%	0.00%	0.19%	0.16%	0.00%	0.00%	0.74%	0.74%	0.00%	0.00%	0.93%	0.93%
		[Manual]	N/A	N/A	N/A	N/A	N/A	N/A	N/A	N/A	N/A	N/A	N/A	N/A
CRITERION 2	Overheating if We > 6	We =	N/A	N/A	N/A	N/A	N/A	N/A	N/A	N/A	N/A	N/A	N/A	
CRITERION 3	Overheating if ΔT >4	max ΔT =	-1.36	-1.36	0.84	0.96	0.27	-1.67	0.53	-1.58	0.39	-1.76	0.88	-1.61

WHITECHAPEL 1999/2000			Mid Terrace				Mid Flat				Top Flat			
			Average Occupancy		Continuous Occupancy		Average Occupancy		Continuous Occupancy		Average Occupancy		Continuous Occupancy	
			Z1 GF	Z2 1F	Z1 GF	Z2 1F	1a Kitchen	1b Bedrooms	1a Kitchen	1b Bedrooms	1a Kitchen	1b Bedrooms	1a Kitchen	1b Bedrooms
CRITERION 1	Overheating if Result >3%	[Energy +]	0.00%	0.00%	0.14%	0.16%	0.05%	0.03%	1.09%	1.09%	0.03%	0.00%	0.90%	0.90%
		[Manual]	N/A	N/A	N/A	N/A	N/A	N/A	N/A	N/A	N/A	N/A	N/A	N/A
CRITERION 2	Overheating if We > 6	We =	N/A	N/A	N/A	N/A	N/A	N/A	N/A	N/A	N/A	N/A	N/A	
CRITERION 3	Overheating if ΔT >4	max ΔT =	-1.22	-1.37	0.85	0.97	0.43	-1.81	0.61	-1.06	0.39	-1.94	0.79	-1.56

ISLINGTON 1961/1990			Mid Terrace				Mid Flat				Top Flat			
			Average Occupancy		Continuous Occupancy		Average Occupancy		Continuous Occupancy		Average Occupancy		Continuous Occupancy	
			Z1 GF	Z2 1F	Z1 GF	Z2 1F	1a Kitchen	1b Bedrooms	1a Kitchen	1b Bedrooms	1a Kitchen	1b Bedrooms	1a Kitchen	1b Bedrooms
CRITERION 1	Overheating if Result >3%	[Energy +]	0.00%	0.00%	0.19%	0.14%	0.00%	0.00%	0.76%	0.76%	0.00%	0.00%	1.09%	1.09%
		[Manual]	N/A	N/A	N/A	N/A	N/A	N/A	N/A	N/A	N/A	N/A	N/A	N/A
CRITERION 2	Overheating if We > 6	We =	N/A	N/A	N/A	N/A	N/A	N/A	N/A	N/A	N/A	N/A	N/A	
CRITERION 3	Overheating if ΔT >4	max ΔT =	-1.23	-1.19	1.28	1.15	0.22	-1.09	1.18	-0.60	0.39	-1.47	1.87	-0.30

- N/A Calculation not necessary
- Manual calculation required
- Compliance with TM52
- Not compliance with TM52

4.2 Future

Islington is the only location in central London with available probabilistic projections to quantify the future effect of the UHI and climate change in energy consumption and comfort levels. Prediction weather data were the foundation of the following calculations based in two climatic scenarios: average prediction (50th percentile probability and medium level emissions) and worst case scenario (90th percentile probability and high emissions scenario).

4.2.1 Scenario 1: Medium emissions levels - 50th percentile probability

4.2.1.1 Energy Consumption

The figures in this section show the relative annual energy consumption compared to different baselines to analyse the future evolution of the UHI, climate change and the combination of both:

- The red column compares the present and future energy consumption of the archetypes located in Islington with the energy consumption of Islington at present, displaying the effect of climate change only.
- The yellow column compares present and future results from simulations in Islington with the results of simulations carried out in St Albans in the same year. This column displays the evolution in time of the UHI only.
- The orange column compares present and future results obtained in Islington with present results in St Albans, showing the evolution of the combination of UHI and climate change together.
- Finally, the grey column also displays the evolution of the combination of climate change and UHI together compared with Uxbridge results, as much relevant literature about London's UHI uses Uxbridge as the baseline location for calculations (Watkins et al, 2002; Kolokotroni et al, 2008 & 2009; Oikonomou et al, 2012).

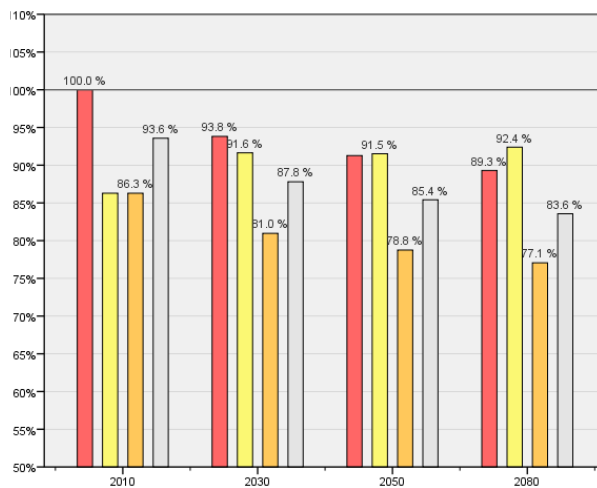

Figure 3. Terraced House – Average Occupancy. Relative annual energy consumption. Medium emissions scenario

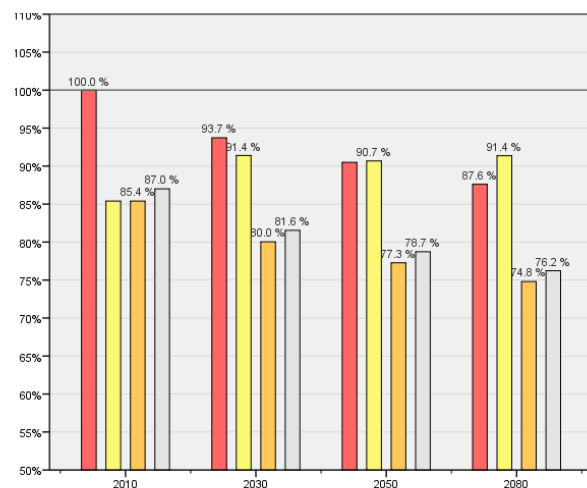

Figure 4. Top Flat – Continuous Occupancy. Relative annual energy consumption. Medium emissions scenario

Figures 3 and 4 show two tendencies. Firstly, climate change progressively reduces the relative energy consumption in all the archetypes because the heating period in winter is shorter and the rest of the loads remain constant in naturally ventilated buildings. Relative energy reductions due to climate change reach 10% by 2080 in all typologies. The effect of the UHI in the energy consumption of buildings follows the opposite trend. However, this does not mean that the UHI intensity decreases. This trend is caused by the reduction of the relative importance of the heating loads compared with the rest of the energy loads. The combination of both UHI and climate change show that the effect of climate change will have a much higher influence in relative energy consumption than the UHI. Again, results between the terraced house and mid flat are very similar. Complete results for all typologies and occupancy profiles can be found elsewhere (Lafuente, 2013).

4.2.1.2 Comfort

Table 3 shows the energy comfort compliance according to TM52 criteria for Islington at present, 2030, 2050 and 2080. Results show that in the defined medium emissions scenario, all baseline archetypes are resilient to climate change and will succeed keeping interior conditions within comfortable levels.

Table 2. Future comfort compliance in Islington according to TM52 in central locations – Medium emissions scenario

ISLINGTON DSY Medium Emissions 50th Percentile			Terraced house															
			Average Occupancy								Continuous Occupancy							
			1961-1990		2030		2050		2080		1961-1990		2030		2050		2080	
			Z1 GF	Z2 1F	Z1 GF	Z2 1F	Z1 GF	Z2 1F	Z1 GF	Z2 1F	Z1 GF	Z2 1F	Z1 GF	Z2 1F	Z1 GF	Z2 1F	Z1 GF	Z2 1F
CRITERION 1	Overheating if Result >3%	[Energy +]	0.00%	0.00%	0.00%	0.03%	0.11%	0.00%	0.03%	0.05%	0.19%	0.14%	0.27%	0.38%	1.23%	1.01%	0.41%	0.33%
		[Manual]	N/A	N/A	N/A	N/A	N/A	N/A	N/A	N/A	N/A	N/A	N/A	N/A	N/A	N/A	N/A	N/A
CRITERION 2	Overheating if We > 6	We =	N/A	N/A	N/A	N/A	N/A	N/A	N/A	N/A	N/A	N/A	N/A	N/A	N/A	N/A	N/A	N/A
CRITERION 3	Overheating if ΔT >4	max ΔT =	-1.23	-1.19	-0.11	-0.54	1.01	0.83	0.66	0.97	1.28	1.15	0.56	0.99	1.66	1.59	1.12	1.26

ISLINGTON DSY Medium Emissions 50th Percentile			Mid Flat															
			Average Occupancy								Continuous Occupancy							
			1961-1990		2030		2050		2080		1961-1990		2030		2050		2080	
			1a Kitchen	1b Bedrooms	1a Kitchen	1b Bedrooms	1a Kitchen	1b Bedrooms	1a Kitchen	1b Bedrooms	1a Kitchen	1b Bedrooms	1a Kitchen	1b Bedrooms	1a Kitchen	1b Bedrooms	1a Kitchen	1b Bedrooms
CRITERION 1	Overheating if Result >3%	[Energy +]	0.00%	0.00%	0.05%	0.08%	0.16%	0.05%	0.08%	0.05%	0.76%	0.76%	1.25%	1.36%	2.18%	2.23%	1.42%	1.42%
		[Manual]	N/A	N/A	N/A	N/A	N/A	N/A	N/A	N/A	N/A	N/A	N/A	N/A	N/A	N/A	N/A	N/A
CRITERION 2	Overheating if We > 6	We =	N/A	N/A	N/A	N/A	N/A	N/A	N/A	N/A	N/A	N/A	N/A	N/A	N/A	N/A	N/A	N/A
CRITERION 3	Overheating if ΔT >4	max ΔT =	0.22	-1.09	0.97	-0.80	0.86	-0.49	1.21	-0.73	1.18	-0.60	1.47	-0.82	1.15	-0.40	1.67	-0.63

ISLINGTON DSY Medium Emissions 50th Percentile			Top Flat															
			Average Occupancy								Continuous Occupancy							
			1961-1990		2030		2050		2080		1961-1990		2030		2050		2080	
			1a Kitchen	1b Bedrooms	1a Kitchen	1b Bedrooms	1a Kitchen	1b Bedrooms	1a Kitchen	1b Bedrooms	1a Kitchen	1b Bedrooms	1a Kitchen	1b Bedrooms	1a Kitchen	1b Bedrooms	1a Kitchen	1b Bedrooms
CRITERION 1	Overheating if Result >3%	[Energy +]	0.00%	0.00%	0.05%	0.05%	0.16%	0.05%	0.14%	0.00%	1.09%	1.09%	2.10%	2.23%	3.05%	3.10%	3.54%	3.57%
		[Manual]	N/A	N/A	N/A	N/A	N/A	N/A	N/A	N/A	N/A	N/A	N/A	N/A	1.60%	0%	1.30%	0%
CRITERION 2	Overheating if We > 6	We =	N/A	N/A	N/A	N/A	N/A	N/A	N/A	N/A	N/A	N/A	N/A	N/A	N/A	N/A	N/A	N/A
CRITERION 3	Overheating if ΔT >4	max ΔT =	0.39	-1.47	0.39	-1.61	1.45	0.01	1.90	0.64	1.87	-0.30	1.98	-0.32	1.98	0.16	2.23	0.53

N/A	Calculation not necessary
	Manual calculation required
	Compliance with TM52
	Not compliance with TM52

The comparison of these results with Table 1 (present situation) shows a clear tendency towards overheating in all the simulated locations. Particularly Criterion 1 provides a false positive in Islington in 2050 and 2080 for the continuous occupancy profile. This is a result of Energy Plus calculations being more restrictive than TM52 when defining overheating. TM52 allows the rounding off to the nearest degree and therefore, if any of the archetypes do not comply with the criterion's limits, a manual calculation of the overheating hours according to TM52 has been carried out to corroborate noncompliance. In Islington the manual calculation confirmed compliance, meaning that more than half of the time that the temperature was above the upper comfort threshold, the difference was less than half degree. This difference is considered overheating by Energy Plus, but not by the TM52. In any case, this location is very close to overheating in the probabilistic scenario.

4.2.2 Scenario 2: High emissions levels - 90th percentile probability

Results obtained from the worst case scenario show the same tendencies outlined in the medium emissions scenario, but with a sharper effect in relative energy consumption.

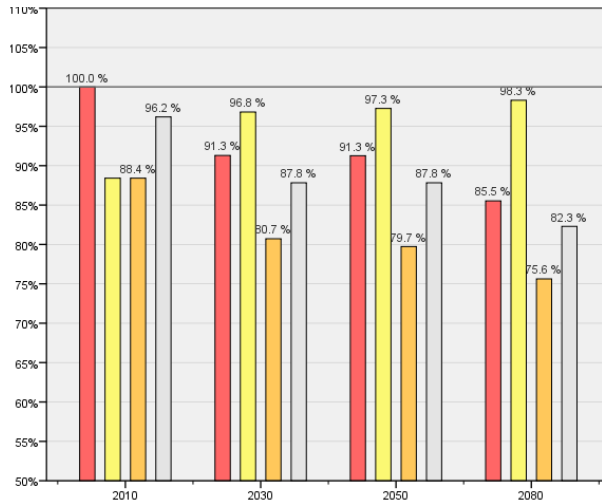

Figure 5. Terraced House – Continuous Occupancy. Relative annual energy consumption

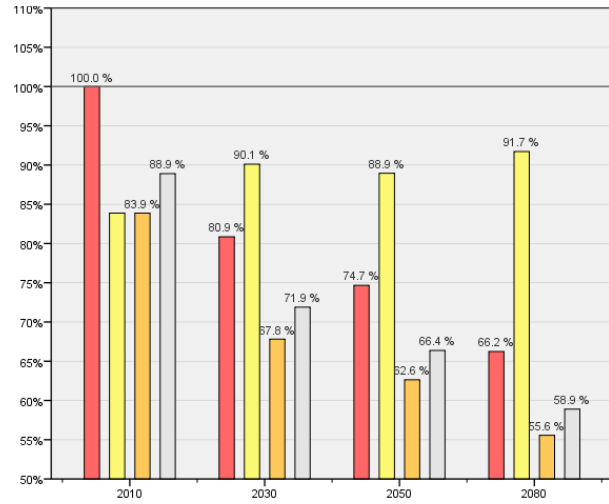

Figure 6. Top Flat – Average Occupancy. Relative annual energy consumption. High emissions scenario

Figure 5 shows that by 2080 heating will be almost unnecessary and therefore, the effect of the UHI in the relative energy consumption almost disappears. The reduction of the heating period is due to global warming and subsequently, the relative energy consumption in the most exposed typology is reduced in one third.

However, in the high emissions scenarios by 2080 all the typologies will suffer severe overheating and the most exposed ones will suffer it by 2050 (Table 3).

Table 3. Future comfort compliance in Islington according to TM52 in central locations – High emissions scenario

ISLINGTON DSY High Emissions 90th Percentile			Terraced house																							
			Average Occupancy								Continuous Occupancy															
			2030				2050				2080				2030				2050				2080			
			Z1 GF	Z2 1F	Z1 GF	Z2 1F	Z1 GF	Z2 1F	Z1 GF	Z2 1F	Z1 GF	Z2 1F	Z1 GF	Z2 1F	Z1 GF	Z2 1F	Z1 GF	Z2 1F	Z1 GF	Z2 1F	Z1 GF	Z2 1F				
CRITERION 1	Overheating if Result >3%	[Energy +]	0.00%	0.00%	0.14%	0.00%	0.14%	0.08%	1.25%	0.22%	0.19%	0.14%	0.57%	0.65%	1.01%	1.09%	4.17%	3.40%								
		[Manual]	N/A	N/A	N/A	N/A	N/A	N/A	N/A	N/A	N/A	N/A	N/A	N/A	N/A	N/A	N/A	2.20%	0.70%							
CRITERION 2	Overheating if We > 6	We =	N/A	N/A	N/A	N/A	N/A	N/A	31-Jul = 51	N/A	N/A	N/A	N/A	N/A	N/A	N/A	31-Jul = 51									
CRITERION 3	Overheating if ΔT > 4	max ΔT =	-1.23	-1.19	1.35	1.60	0.61	0.92	4.59	4.81	1.28	1.15	1.85	1.99	0.84	1.30	4.59	4.81								

ISLINGTON DSY High Emissions 90th Percentile			Mid Flat																							
			Average Occupancy								Continuous Occupancy															
			2030				2050				2080				2030				2050				2080			
			1a Kitchen	1b Bedrooms	1a Kitchen	1b Bedrooms	1a Kitchen	1b Bedrooms	1a Kitchen	1b Bedrooms	1a Kitchen	1b Bedrooms	1a Kitchen	1b Bedrooms	1a Kitchen	1b Bedrooms	1a Kitchen	1b Bedrooms	1a Kitchen	1b Bedrooms	1a Kitchen	1b Bedrooms				
CRITERION 1	Overheating if Result >3%	[Energy +]	0.00%	0.00%	0.22%	0.11%	0.16%	0.05%	0.90%	0.05%	0.76%	0.76%	1.23%	1.28%	2.89%	2.94%	7.60%	7.65%								
		[Manual]	N/A	N/A	N/A	N/A	N/A	N/A	N/A	N/A	N/A	N/A	N/A	N/A	N/A	N/A	N/A	7.16%	0.49%							
CRITERION 2	Overheating if We > 6	We =	N/A	N/A	N/A	N/A	N/A	N/A	31-Jul = 57	N/A	N/A	N/A	N/A	N/A	N/A	N/A	N/A	N/A								
CRITERION 3	Overheating if ΔT > 4	max ΔT =	0.22	-1.09	2.09	-0.98	1.17	-0.83	4.98	2.71	1.18	-0.60	2.18	-0.44	1.47	-0.79	5.00	2.73								

				Top Flat															
				Average Occupancy								Continuous Occupancy							
				1961-1990		2030		2050		2080		1961-1990		2030		2050		2080	
				1a Kitchen	1b Bedrooms	1a Kitchen	1b Bedrooms	1a Kitchen	1b Bedrooms	1a Kitchen	1b Bedrooms	1a Kitchen	1b Bedrooms	1a Kitchen	1b Bedrooms	1a Kitchen	1b Bedrooms	1a Kitchen	1b Bedrooms
CRITERION 1	Overheating if Result >3%	[Energy +]		0.00%	0.00%	0.33%	0.11%	0.33%	0.11%	1.36%	0.11%	1.09%	1.09%	3.89%	3.98%	6.84%	6.94%	#####	#####
		[Manual]		N/A	N/A	N/A	N/A	N/A	N/A	N/A	N/A	N/A	N/A	N/A	1.74%	0.00%	3.95%	0.00%	#####
CRITERION 2	Overheating if We > 6	We =		N/A	N/A	N/A	N/A	N/A	N/A	31-Jul = 62	N/A	N/A	N/A	N/A	31-Jul = 19	N/A	N/A	N/A	N/A
CRITERION 3	Overheating if ΔT > 4	max ΔT =		0.39	-1.47	2.48	0.19	2.05	0.49	5.58	3.62	1.87	-0.30	2.66	0.22	2.17	0.21	5.58	3.31

N/A	Calculation not necessary
 	Manual calculation required
 	Compliance with TM52
 	Not compliance with TM52 = OVERHEATING

Further simulations made for Heathrow show similar predictions of overheating (Lafuente, 2013). Therefore, in the high emissions scenario, London’s residential stock will progressively not be able to cope with overheating between 2050 and 2080. Higher UHI intensity will define what areas will suffer from overheating first.

5 Discussion

According to these results, London is currently located in a climatic zone where the UHI saves energy in the residential stock during winter and does not cause overheating in summer. Climate change will gradually displace the climatic zones and by 2080 London could be located in a zone where the UHI would not save any significant amount of energy in winter, but would contribute to overheating during summer.

This prediction can only be applied to new homes or buildings that have been upgraded to current building standards. In these dwellings the UHI will be saving energy for at least thirty years as long as residents know how to use passive strategies to keep interior conditions within comfortable levels. This might not be always the case.

However, the scope of this research did not include older buildings. U-values have improved significantly in the last twenty years, but air infiltration requirements have not significantly changed. Older buildings with higher U-values will experience significantly higher heat gains in summer which would affect comfort levels. These higher gains may not be properly balanced by air infiltration or ventilation. This would probably affect the energy savings potentially caused by the UHI in winter. Further research is required to place in context the current and future performance of the older residential stock.

For the studied typologies, the thermal effects of the UHI in London at present should not be a major concern for energy use and comfort conditions, except for other factors such as pollution that can directly deteriorate population’s health. Nevertheless given the evolution of CO2 emissions and climate change predictions – mitigation of the UHI should be encouraged to avoid overheating in the residential stock. Suitable retrofitting strategies can further delay the risk of overheating, and the energy savings caused by the UHI would not be relevant enough to justify inaction towards mitigation.

If current residential stock cannot cope with overheating in the future, residents will always take action to restore comfort. A higher proportion of dwellings may install cooling systems and the energy savings currently caused by the UHI could revert into higher energy

consumption. This tendency would probably be confirmed by other comfort models more commonly adopted in air conditioned spaces.

6 Conclusions

Thermal comfort

Interior conditions in London's residential stock can currently be kept within comfortable levels in every location and UHI intensities. Properties with poorer thermal performance than the baseline defined in this article could be retrofitted to this standard..

Energy performance

Depending on the occupancy profile, the UHI effect is currently saving up to 10-15% energy in the naturally ventilated residential stock.

Climate change

The residential stock might start to suffer overheating after 2050 in a high emissions scenario. The energy savings caused by the UHI effect will also be significantly reduced in the future – and the UHI will not disappear. Even though the mitigation of the UHI might not define a major concern for the residential stock at present, it should be mitigated in the future depending on the evolution of the CO₂ emissions.

Global warming will have dramatic consequences in London's residential stock: By 2080 every home in London might suffer from overheating in a high emissions scenario.

7 Acknowledgements

Weather files from different locations in London's UHI were provided by Prof Maria Kolokotroni from Brunel University.

8 References

BSI, 2007. *BS EN 15251:2007 Indoor environmental input parameters for design and assessment of energy performance of buildings addressing indoor air quality, thermal environment, lighting and acoustics*. London: British Standards Institution

CIBSE, 2013. *TM52:2013. The limits of thermal comfort: avoiding overheating in European buildings*. London. The Chartered Institution of Building Services Engineers

GLA – Greater London Authority, 2006. *London's urban heat island – A summary for decision makers*. Greater London Authority, London

Humphreys, MA, 1978. Outdoor temperatures and comfort indoors. *Building Research and Practice*. 6 (2): 92-105.

Kolokotroni, M; Giannitsaris, I; Watkins, R, 2006. The effect of the London urban heat island on building summer cooling demand and night ventilation strategies. *Solar Energy*. 80. 383–392

Kolokotroni, M; Giridharan, R, 2008. Urban heat island intensity in London: An investigation of the impact of physical characteristics on changes in outdoor air temperature during summer. *Solar Energy*. 82 (2008) 986–998

Kolokotroni, M; Giridharan, R, 2009. Urban heat island characteristics in London during winter. *Solar Energy*. 83. 1668–1682

Lafuente, JJ, 2013. *The Urban Heat Island Effect in London's residential Stock: Energy consumption and risk of overheating*. MSc. London Metropolitan University.

Mavrogianni, A; Wilkinson, P; Davies, M; Biddulph, P; Oikonomou, E, 2012. Building characteristics as determinants of propensity to high indoor summer temperatures in London dwellings. *Building and Environment*. 55. 117-130

Oikonomou, E; Davies, M; Mavrogianni, A; Biddulph, P; Wilkinson, P; Kolokotroni, M, 2012. Modelling the relative importance of the urban heat island and the thermal quality of dwellings for overheating in London. *Building and Environment*. 57. 223-238

ONS – Office of National Statistics, 2011. *Census 2011* [Online] Available at: <http://www.ons.gov.uk/ons/guide-method/census/2011/index.html> (Accessed: 01/04/2013)

University of Exeter, 2011. *Prometheus Project* [Online] Available at: <http://emps.exeter.ac.uk/research/energy-environment/cee/projects/prometheus/> (Accessed: 25/05/2013)

Watkins, R; Palmer, J; Kolokotroni, M; Littlefair, P; 2002. The balance of the annual heating and cooling demand within the London heat island. *Building Service Engineering Research and Technology* 23 (4), 207–213.

WHO – World Health Organisation, 2008. Improving public health response to extreme weather/heat-waves – *EuroHEAT, Meeting Report*, 22-23 March 2007, Bonn, Germany, Copenhagen: WHO Regional Office for Europe

ZCH - Zero Carbon Hub, 2009. *Defining a fabric energy efficiency standard for zero carbon homes* [Online] Available at: <http://www.zerocarbonhub.org/resources.aspx> (Accessed: 09/05/2013)

Proceedings of 8th Windsor Conference: *Counting the Cost of Comfort in a changing world*, Cumberland Lodge, Windsor, UK, 10-13 April 2014. London: Network for Comfort and Energy Use in Buildings, <http://nceub.org.uk>

Thermal acceptability for urban parks in tropics: Evaluating the effects of environmental attributes on user perceived controls

Indrika Rajapaksha and Chathuri Rathnayaka

Department of Architecture, University of Moratuwa, Sri Lanka, indrika@uom.lk

Abstract

Though wider diversities of environmental attributes are intrinsic in water fringed urban parks, these parks are less represented in the previous studies. Thus the study aims to explore the impact of environmental attributes of settings on user perceived controls for enhancing daytime thermal acceptability of water fringed urban parks in Colombo, Sri Lanka. The study investigated seven diversified settings which demonstrate varying shading levels and environmental attributes with visual integration of water surfaces. Although predicted thermal perception indices signify uncomfortable microclimates majority of the visitors are accepting high PET range of 28-40°C. Enhanced thermal acceptability of these parks is related to visitor's perceived control on choice of place. The tolerance of extremely hot microclimates is encouraged through more natural environmental attributes of the settings which contribute to visitor's expectation of view for high degree of perceived control. Thus microclimate planning which link visitor's expectation through natural environmental attributes of urban parks is prime importance for usability and vivacity of outdoor settings in tropical climates.

Keywords: Tropics, thermal acceptability, urban parks, perceived control, environmental attributes

1 Introduction

Urban outdoor areas are vital spatial elements of an urban fabric, which contributes to enhance quality of life within cities. With, the focus of urban population growth for next 30 years in developing countries of Asia, tropical urbanization is an appealing global phenomenon. Haphazard densification, declining urban green plot ratio and emergent urban heat islands in tropical cities contribute to varying warmer outdoor microclimates.

Over the recent years urban outdoor environments such as, parks and squares in various countries and climate zones have received increasing research attention. Many studies have investigated the outdoor thermal environments, thermal adaptation and utilization of urban outdoor spaces in moderate climates in European cities including; Cambridge, the UK (Nikolopoulou, M. et al.,2001); Göteborg, Sweden (Thorsson et al.,2004); Kassel, Germany(Katzschner,2006), Athens, Greece (Nikolopoulou et al.(2007); Szeged, Hungary (Kántor, N. et al.,2011); Hague, Eindhoven and Groningen, the Netherlands (Lenzholzer, S. et al.,2010).

Similar attention was evident for onsite research in outdoor spaces with hot and humid subtropical and tropical climatic conditions in quite a few Asian cities such as, Taichung, Taiwan (Lin, T.,2009; Lin, C. et al.2013), Shanghai, China (Xu,J. (2010), Singapore (Yang.W.,2013), Dhaka, Bangladesh (Ahmed,K.2003), Salngor, Malaysia (Nasir et al.2013).

Although warm outdoor microclimates and sunlight encourages the daytime use of outdoor spaces in moderate climates, shade is the most predominant design strategy to achieve microclimates with cool temperature in tropical climates.

Outdoor microclimate is an integral factor for the use of an urban outdoor space (Nikolopoulou,2003). The exposure to diversified environmental attributes of outdoor local microclimates greatly affects people's perception of thermal environment and influence their behaviour and use. Moreover, choice for different shading levels provided by trees and built-in structures in outdoor parks encourage higher usage rate and accomplish higher level of thermal comfort (Lin, 2009). Thus the understanding of the complexities of different urban outdoor microclimates derive significant urban design implications to promote comfortable and healthy urban outdoor spaces to enhance urban livability and vivacity.

Integration of water surfaces and green spaces of an urban park signify the most important elements in an urban ecology. The naturalness of these parks exhibit environmentally diversified settings for its users. People in these natural environments, which are free from artificiality, are able to tolerate extensive variations of physical environment when there is a direct connection with the natural settings (Griffiths et al, 1987). Moreover negative emotional responses are reduced when people are provided with high degree of control over their environment (Nikolopoulou, 2004). While actual controls are minimal for the users in thermally uncomfortable outdoor microclimates of tropical urban parks, the potential for free choice on perceived control is prime importance.

Majority of thermal comfort studies on urban parks in hot and humid climates have investigated the landscaping settings formed by varying layouts of vegetation for different shading levels and microclimates (Lin, 2009). Though wider diversities of natural milieus with free choices for users are intrinsic in water fringed urban parks, these parks are less represented in the previous studies. Moreover, relatively little attention is given for urban parks in tropical climates and densely populated cities in South Asian region.

Thus the study aims to understand the influence of diversified environmental attributes on user perceived controls for enhancing daytime thermal acceptability in water fringed urban parks in the tropical city of Colombo, Sri Lanka.

2. Method

2.1 Description of study Parks

The study parks are located in the city of Colombo (6°55'N, 79°51'E at an altitude of 8m), in western Sri Lanka. The city has a tropical monsoon climate with uniformly high temperatures with high humidity. Mean monthly temperature over the year varies from 26°C to 29°C with the highest average in March to April (maximum temperature, 36°C). Mean monthly relative humidity varies from 60-80% during a year. Colombo experiences long hours of sunshine and mean hourly global horizontal radiation varies from 398 to 530 W/m² within a year with the highest in the month of March (maximum hourly global radiation, 1030 W/m²). Consequently, these environmental parameters characterize the tropical climate of Colombo.

Figure 1 shows the layout of parks and water bodies in the Colombo Metropolitan Region (CMR) and the surrounding environment of the selected water fringed parks of this study.

Beira is a manmade lake and the Beira Lake park (BL) is an island sited in the center of 0.6 km² of lake in the city of Colombo. The city of Colombo represents the highest density conurbation of Sri Lanka, with a population density of 15,000 persons/km on 37km² land area.

Water's Edge park (WE) is situated in Sri Jayawardenapura, Kotte, the satellite city of Colombo, which contains the wetland open parks with immense bio diversity. This moderately dense city with 3305 persons/km is covering a land area of 17km². The wetland open environment of the park WE and compact urban vicinity of BL is shown in Figure 1A and B.

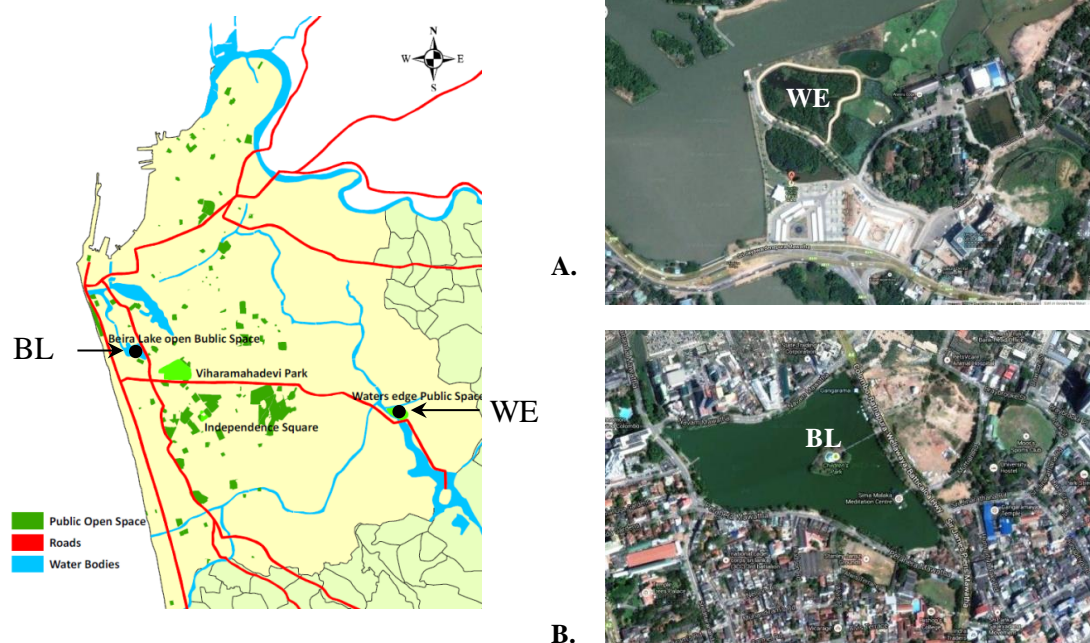

Figure 1 Parks and water bodies in Colombo Metropolitan Region (CMR) and the vicinity of study parks (A) Water's Edge (WE) and (B) Beira Lake (BL) park

Both parks are visually integrated with the surrounding water surfaces but the differences in landscaping layouts promote opposing environmental attributes. A park with more natural ground surfaces such as grass, sand and gravel pathways portray natural environmental attributes in contrary to the park with hard surfaces such as paved areas. Continuous grass areas with trees, sand paths and less hard surfaces in WE park preserve the naturalness of its environment compares to landscape layout with more paved ground surfaces and built-in structure in BL park.

2.2 Investigated settings and their environmental attributes

To explore the relationship between environmental attributes and the visitor's perceived controls the prominent settings were selected based on the number of people in each setting. The environmental attributes of these settings includes, shading level, ground cover, visual integration with surrounding water surfaces and overall character of the environment.

Shading level was assessed using the sky view factor (SVF), which represents a ratio of an open area of a location over the entire overhead view. The values of SVF varies from 0, the "entirely shaded" to 1, the "entirely unshaded" locations. RayMan model, version 2.1 (Matzarakis et al., 2007) was used to generate polar diagrams of SVF with

trees as the main obstacles in both parks. Input parameters are consist of location of trees and details such as trunk height, and diameters of canopy and trunk.

Beira lake park (BL) is consists of three populated settings such as North lake view (NLV), South lake view (SLV) and Dome shelter (DS). These locations demonstrate shading levels of entirely shaded (SVF=0) in DS and moderately shaded ($0.1 < SVF < 0.6$) in NLV and SLV. Except for few grass covered areas 80% of the total area is paved with brick and concrete blocks. Figure 2 shows the area photo, polar diagram of obstacles and calculated SVF of the selected three settings of BL park.

The four prominent settings in WE park are West Lake Edge (WLE), North Lake Edge (NLE), Sand Path (SP) and Tree Trail (TT). WLE and NLE are with low shading levels ($SVF > 0.6$), SP is close to unshaded conditions with the highest SVF of 0.85 and TT is almost shaded with the lowest SVF of 0.27 ($0.1 < SVF < 0.6$). Most of the ground area is covered with grass and 20% of the paved area is consists of a tarred walkway in TT and the sand path. Area photos, polar diagram of obstacles and SVF of the four settings in the park WE is shown in Figure 3.

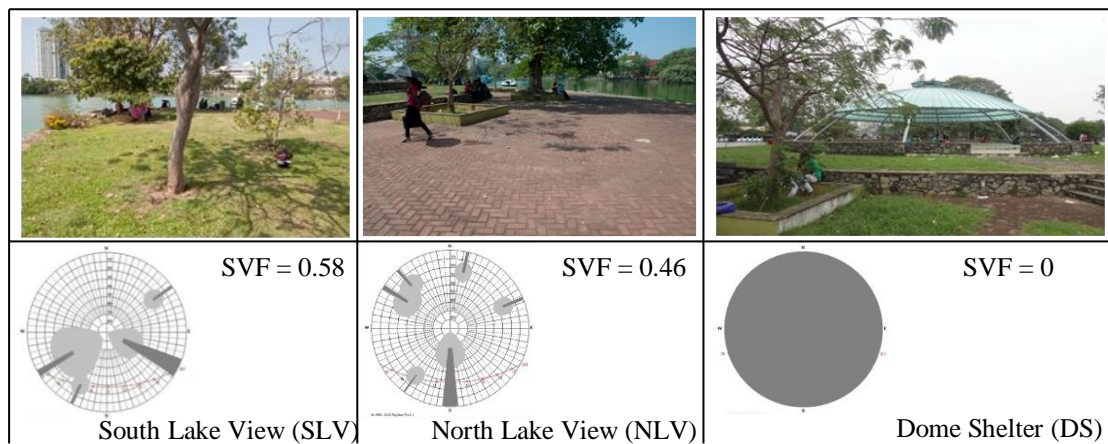

Figure 2 Investigated settings and environmental attributes of Beira Lake (BL) park

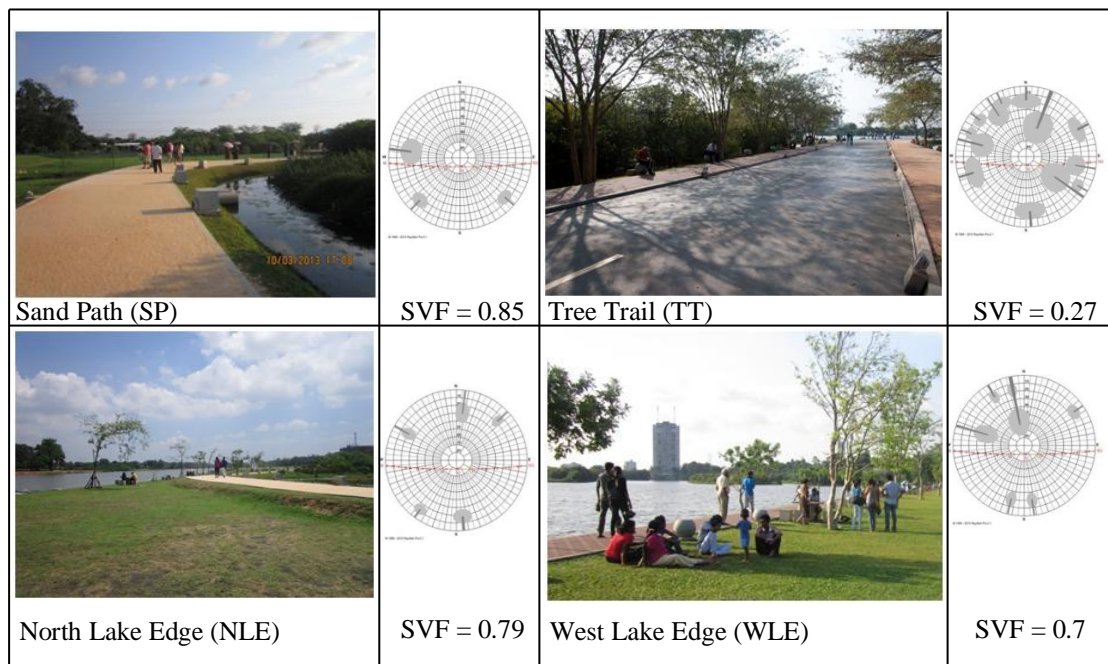

Figure 3 Investigated settings and environmental attributes of Water's Edge (WE) park

2.3 Microclimatic measurements

An onsite field investigation were performed to measure microclimatic parameters such as air temperature (T_a), relative humidity (RH), surface temperature (T_s) and wind velocity (v). These microclimatic parameters are shown to be significant factors in previous studies.

A combination of portable instruments such as, Temperature and Relative Humidity data loggers, thermocouples and hot wire anemometers, which complies with ISO 7726 standards (7726 ISO,1998) were assembled to monitor the microclimate during the interview survey. T_a and RH were measured using high-accuracy Hobo H8 data loggers with built in temperature and relative humidity sensors.

Each data logger was placed in a ventilated plastic shield painted in white to protect from direct sun exposure. All measurements were collected at 1.1m above ground in shaded locations. The sampling and logging times are set to 5 seconds and 1 minute respectively.

Thermal environment of each designated zone were monitored with two data loggers and positioned in the most populated pocket of the investigated setting. Moreover, wind velocity was measured closer to each respondent at the time of interview survey. All equipment have been tested and calibrated before the survey and the time was synchronized with the standard time of the Colombo Meteorological station. Cloud cover and Global radiation were acquired from a local official weather station situated in 8km away from the study parks.

This study was conducted during the daytime hours of Saturday and Sunday in the hottest month of March. There were no rain during this month and the suitable days were selected excluding social events and holidays to avoid unusual increase and decrease of users of the parks. Field investigation with simultaneous interview survey in BL and WE parks were performed between 08.00h and 18.00h during the second and third weekends of March 2013 respectively.

2.4 Questionnaire interview

The primary objective of the questionnaire interview is to assess the subjective perceived control of visitors on actual thermal sensation and acceptability. A total of 100 visitors from each park were selected randomly and the interviews were conducted in investigated settings of both parks. These interviews were performed in Sinhalese and each subject was interviewed for duration of 10 minutes.

The structure of the questionnaire was formulated using the previous interrelated studies on urban outdoor parks (Lin,2009; Lin et al., 2011; Hwang,2010; Oliveria,2007; Stathopoulson,2004). The questionnaire is composed of four parts such as background, factors of perceived control, thermal perception and thermal acceptability.

The questions on background inform subject's demographic details, type of clothing and metabolic activities. Subject's perceived control is evident in the questions on choice of selection of place and reason for being in the park. Actual sensation of thermal environment (air temperature) was questioned through ASHRAE 7-point scale, which ranges from (-3) cold to neutral (0) and (+3) hot (ASHRAE 55) The McIntyre 3-point preference scale (Right now I want to be "cooler", "no change" or "warmer) was used for direct assessment of thermal acceptability (acceptable or unacceptable) (ISO,1998)

2.5 Thermal indices

This research is based on widely used thermal perception indices such as Physiologically Equivalent Temperature (PET) and Apparent Temperature (AT) to assess outdoor environment.

RayMan Pro version 2.1 software was used in the calculation of PET values with input data of SVF, cloud cover, microclimatic weather parameters and albedo of ground surfaces. Previous research in different climate zones has established country and region specific thermal perception classifications (TPC) for PET index (Lin & Matzarakis,2008; Matzarakis & Mayer,1996; Monam,2011, Katschner,2011). Table 1 shows TPC for (sub) tropical, temperate and hot arid regions and demonstrates considerable differences of this index in changing climate zones.

Table 1. Thermal perception classification (TPC) for countries representing (sub) tropical, temperate and hot arid climate zones

Taiwan	Western European	Tehran	Germany	Thermal perception	Thermal stress threshold
<22	<13	<17.5	<13	Cool	Moderate cold
22-26	13-18	17.5-25	13-17	Slightly cool	Slight cold
26-30	18-23	26-32	18-28	Comfortable	Comfortable
30-34	23-29			Slightly warm	Slight heat
34-38	29-35	33-36	29-34	Warm	Moderate heat
38-42	35-41	37-40	35-41	Hot	Strong heat
>42	>41	>41	>42	Very Hot	Extreme heat

TPC for (sub) tropical climate of Taiwan has been used as a reference to assess the outdoor thermal environment. Moreover the thermal index apparent temperature (AT) which assessed the interaction of air temperature, relative humidity and wind velocity was used as a comparative index. AT was calculated using the equation 1 and 2 and water vapour pressure was calculated using the equation 2 (Steadman, 1984).

$$AT = T_a + 0.33 * e - 0.70 * v - 4.00 \quad (1)$$

$$e = \frac{RH}{100} * 6.105 * EXP(17.27 * T_a / (237.7 + T_a)) \quad (2)$$

[T_a: air temperature (°C), e:water vapour pressure (hPa), v:wind speed (m/s) and RH: relative Humidity (%)].

A study in Malaysia has showed suitability of AT to assess Malaysians adaptation to hot and humid climates (Nasir et al., 2012).

3.0 Results and Discussion

3.1 Microclimate of investigated settings

The statistical summary of the outdoor microclimatic variables measured in all settings of the parks is given in Table 2. It is apparent that the microclimate of both parks is hot and humid with high air temperature and high humidity. Mean and maximum air temperature of all settings varies in the range of 32.6-34°C and 33.4-35°C in BL park and 32-35.9°C and 32.5-37.1°C in WE park respectively. The lowest air temperature data was observed in DS the shaded zone with permanent built structure in BL park and TT the mostly shaded zone (SVF=0.27) in WE park. Moreover DS and TT were observed for the lowest mean surface temperature of 33.5°C and 29.7°C of BL and WE park respectively.

Table 2 Summary of microclimatic weather condition of investigated locales of the study parks

Setting	T_a		RH		V		T_s	
	Mean	SD	Mean	SD	Mean	SD	Mean	SD
SLV	34.0	0.7	50.4	4.3	1.3	0.2	36.3	1.2
NLV	33.9	0.7	51.7	4.3	1.2	0.6	37.9	0.8
DS	32.6	0.6	60.6	5.7	1.0	0.3	33.5	0.3
WLE	33.6	0.35	55.6	2.7	2.8	1.1	32.3	0.4
NLE	34.2	0.59	53.9	2.0	2.7	0.7	32.4	0.8
SP	35.9	1.2	49.7	6.4	1.7	1.2	38.2	0.6
TT	32.0	0.2	63.1	4.8	2.1	0.6	29.7	0.7

T_a : Air Temperature; RH: Relative Humidity; v: Wind velocity; T_s : Surface Temperature

In both parks similar mean air temperature data was evident in the settings closer to water surfaces. Mean relative humidity of all settings varies in the range of 50-61% and 50-63% in BL and WE park respectively. In both parks settings closer to water surfaces were observed for lower mean relative humidity in comparison to the settings away from the water surfaces. There are no evidences of formation of extreme microclimates in respective to evaporative cooling in the settings closer to water surfaces in both parks. Meteorological data of global solar radiation varies in the range of 23 to 38W/m² and both parks experienced low cloud cover from 2 to 4 Octas. All settings demonstrated relatively constant microclimates with thermally uncomfortable outdoor environments.

3.2 Predicted thermal perception analysis

3.2.1 Physiological Equivalent Temperature (PET)

Figure 5, A and B show the predicted PET from 11h to 16h in different settings of BL and WE parks respectively.

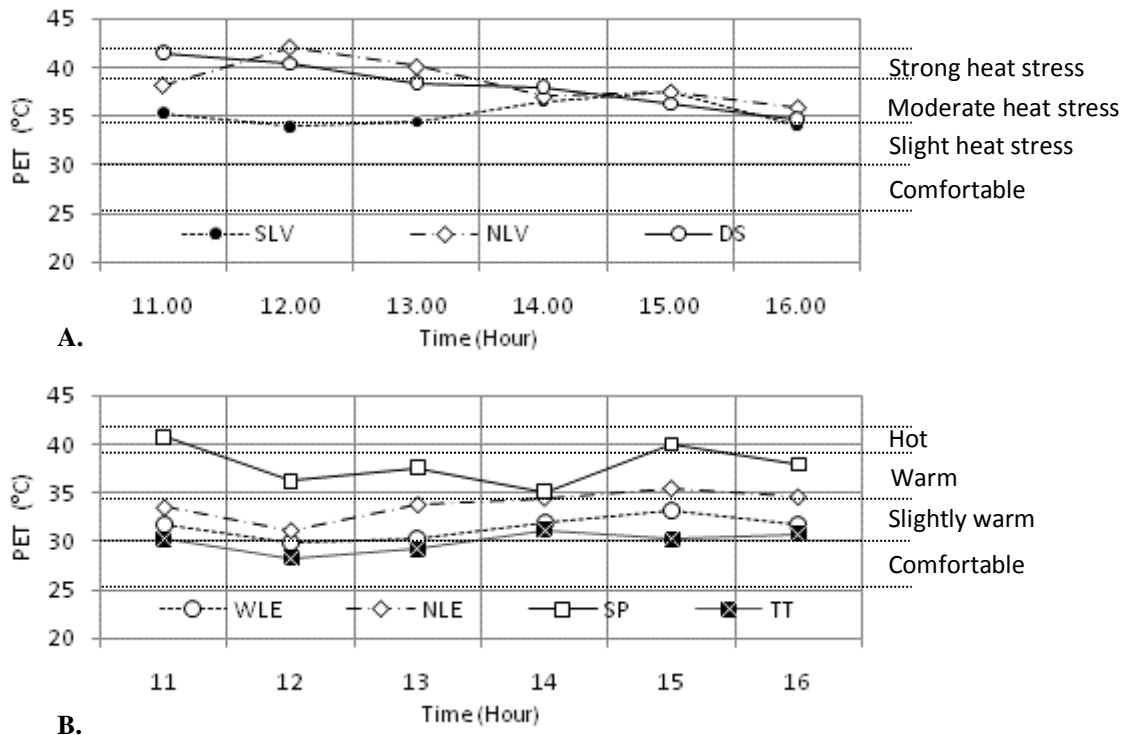

Figure 5 Predicted PET for investigated settings in study parks (A) BL and (B) WE parks

PET varies in the range of 33.9-42°C in BL and 28.3-40.7°C in WE parks. Thermal perception classification for subtropical climates informs that all microclimates represent warm thermal perceptions and slight to strong heat stress threshold for its users.

In WE park a clear relationship is evident in PET and SVF for all settings. Almost unshaded (SVF=0.9) sand path (SP) demonstrates the worst microclimate. In contrary microclimate of the mostly shaded (SVF=0.27) tree trial (TT) represent a comfortable thermal perception and stress threshold for subtropical locations. Shading is an important factor which contributes to modify the outdoor microclimates in tropics. It blocks the short wave radiation and the shadows on ground decrease surface temperatures, reducing long wave radiation (Lin et al. 2010, Toudert et al. 2007 & Hwang et al. 2011). Thus predicted PET informs a comparable microclimatic behaviour of previous studies in hot climates (Lin, 2009; Gulyas et al., 2006).

However a clear relationship of PET and SVF is not evident for all settings of BL park. Similar microclimates are evident in fully shaded (DS) dome shelter (SVF=0) and partially shaded NLV (SVF=0.6). All settings demonstrate microclimates of warm to hot thermal perceptions. Moreover gravel and concrete block paved ground areas with high albedo in NLV and SLV is evident for higher surface temperature. Although shading contributes to modify microclimates the thermal properties of ground surfaces and wind velocities contribute to ameliorate outdoor microclimates in tropics.

3.2.2 Apparent Temperature (AT)

Thermal perception of the apparent temperature index defines limits for comfort and discomfort. AT in the range of 20-29°C is comfortable and beyond 29°C develops varying levels of discomfort reaching to its threshold at 39°C.

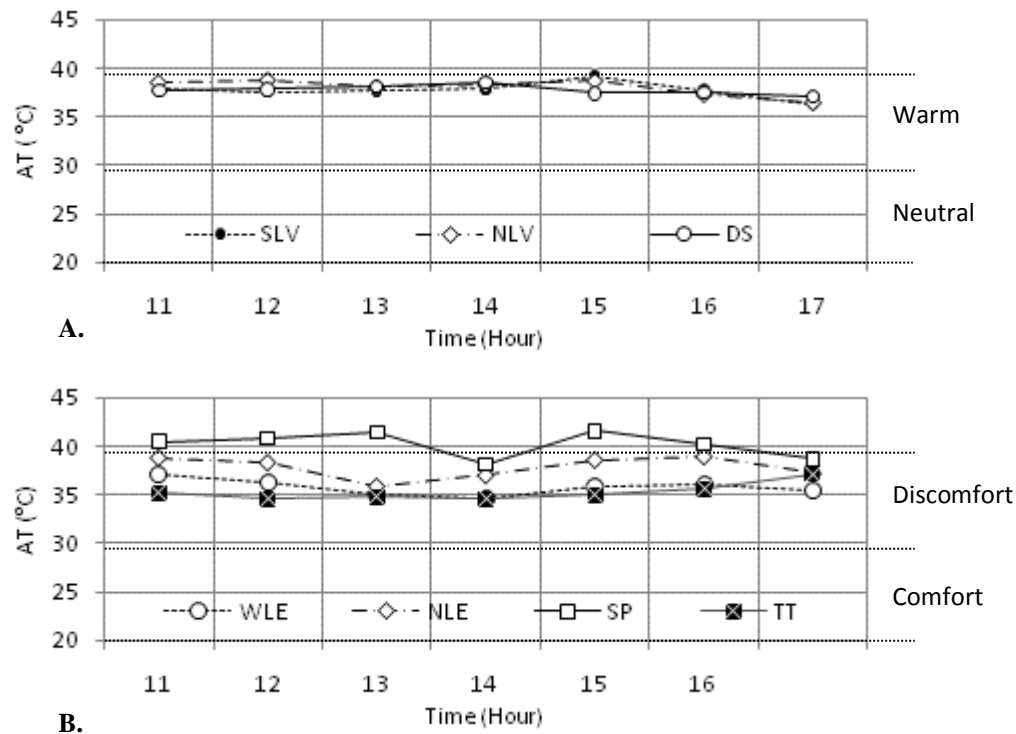

Figure 6 Apparent Temperature for investigated settings of study parks, (A) BL and (B) WE park Outdoor microclimates beyond 39°C demonstrate very hot and extreme heat stress in Tropical climates.

Figure 6, A and B show the predicted AT from 11h to 16h in different settings of BL and WE parks respectively. AT varies in the range of 36.3-39°C in BL and 34.6-41.4°C in WE parks. Microclimate of the parks represents thermal discomfort in varying levels. All locations in BL park is evident for almost same thermal conditions. However in WE park a variation of AT is evident in different locations and the contribution of tree shade on microclimatic modification is noticeable. Findings of this study establish that the influence of water in microclimatic modification is negligible. Landscaping designs with trees and natural ground surfaces are prime factors to generate ameliorating outdoor microclimates in tropics.

3.3 Predicted versus actual thermal sensation and acceptability

Actual thermal sensation of the respondents for ASHRAE 7-point scale and thermal acceptability for 3-point McIntyre scale are compared with the thermal perception levels classified in the sub tropical PET index.

Figure 7, A and B show the comparison of actual thermal sensation (TSV,A) and thermal acceptability (TP,M) with predicted PET for BL and WE parks respectively. Majority of the respondents expressed their thermal sensation as comfortable (neutral). All locations of WE and BL parks represent a neutral TSV of 88% and 91% respectively. Balance 9% of respondents in BL and 3% in WE expressed a TSV of slightly warm and further, 9% in WE park informs their thermal sensation as warm.

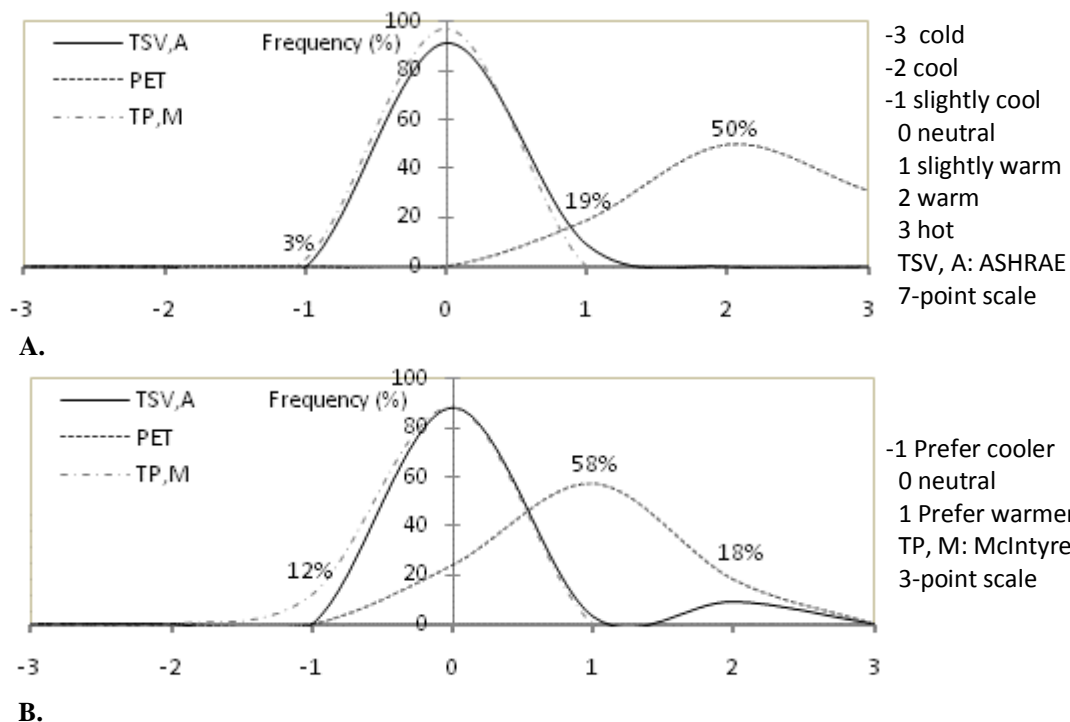

Figure 7 Frequency distribution of Actual thermal Sensation Vote (TSV), Thermal preference and predicted PET for (A) BL and (B) WE parks

Fanger's theory describes TSV in the range of -1, 0, +1 are satisfactory thermal environments (Fanger, 1972). Actual thermal preference results show 97% and 88% of respondents expressed their thermal preference as "no change" in BL and WE park respectively. Thus indicate the microclimates of the parks are accepted as comfortable for its users.

Almost 90% of local respondents expressed thermal sensation as comfortable for higher PET range of 28-40°C. Similar trend was reported for Malaysians accepting higher PET range of 21-39.4°C as comfortable (Nasir et al. 2012). The results established that the respondents are adapted to a higher range of thermal conditions compared with the comfortable range of 26-30°C for subtropical climates.

Thus it is vital to appraise the influence of psychological adaptation potentials for visitors in water fringed park such as naturalness of the settings and its contribution for expectations of visitor's perceived controls. Natural environmental attributes of the settings contribute to visitor's expectations such as choice of place and reasons for being in the park, thus affects the degree of perceived control to enhance the tolerance of uncomfortable outdoor thermal environments in tropics.

4.0 User Perceived controls

4.1 Choice of place

The study explored the influence of environmental attributes of diversified settings on expectation of users in selection of place. Figure 8, A and B show the actual thermal sensation in relation to choice of place in WE and BL park respectively.

Majority of the users have selected locations closer to the surrounding water surfaces as their choice of place. Distribution of users closer to water surfaces in WE and BL parks are 79% and 94% respectively. The most popular choice of place in WE park is the West lake edge (WLE) with 49% of the users and BL park is the South lake view (SLV) with 69% of the users. The fully shaded dome shelter (DS) and almost shaded tree trail (TT) are least preferred locations with 6% and 12% of users in BL and WE park respectively. The high SVF of 0.7 and 0.79 in places closer to water surfaces reveal that shading is not the primary influential factor in selection of place for users in the water fringed parks.

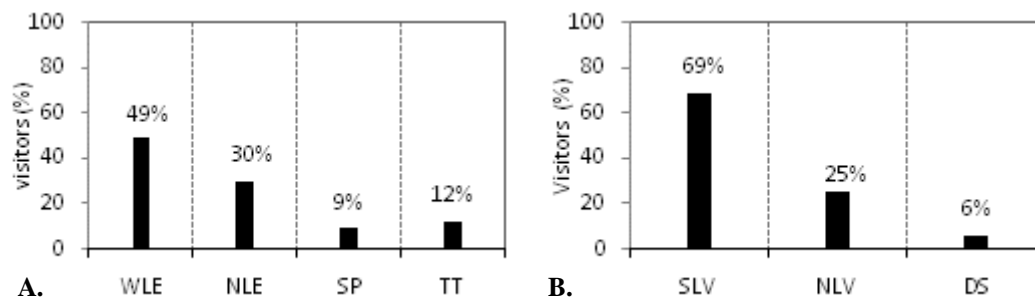

Figure 8 Percentage distribution of user's in different settings of study parks, (A) Water's Edge (WE) and (B) Beira Lake (BL) park

4.1.1 Relationship of place and thermal sensation

Figure 9, A and B show the percentage distribution of thermal sensation vote in relation to choice of place in WE and BL park respectively. Majority of the users (90% in BL and 88% in WE park) expressed their thermal sensation as comfortable. Although DS was not an attractive place within the BL park for all respondents, yet the users expressed their TSV as comfortable. Moreover, 10% of the respondents in SLV voted the location as slightly warm in comparison to comfortable TSV of all respondents in NLV. The lower SVF of 0.47 with more shading in NLV is contributing on comfortable thermal sensation.

Nevertheless, comfortable thermal sensation in comparatively unshaded (SVF ≥ 0.7) West lake edge (WLE) and North lake edge (NLE) in the park WE informs that, shading is not the only contributing factor for thermal acceptability. This is further confirms on the vote of comfortable thermal sensation by 6% out of 9% respondents in the sand path (SP), almost unshaded place with the highest SVF of 0.9 among both parks.

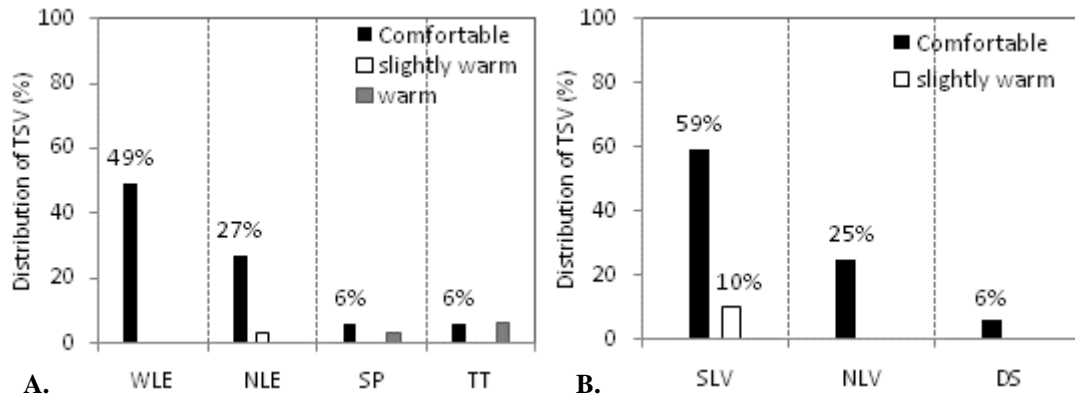

Figure 9 Percentage distribution of user's Thermal Sensation Vote (TSV) in relation to the choice of place in (A) WE and (B) BL park

Statistical assessment on Pearson's Chi square (χ^2) test revealed the relationship of choice of place and actual thermal sensation ($P=0.020 < 0.05$) of the users in WE park is significant. Contrary there is no significant relationship ($P=0.471 > 0.05$) in BL park.

4.1.2. Relationship of place and thermal acceptability

Figure 10, A and B show the percentage distribution of users responses for 3-point McIntyre scale of thermal acceptability in relation to choice of place in WE and BL park respectively. Majority of the users (76% in WE and 94% in BL park) in the places which visually integrate with water surfaces have expressed their thermal preference as 'no change' and acceptable.

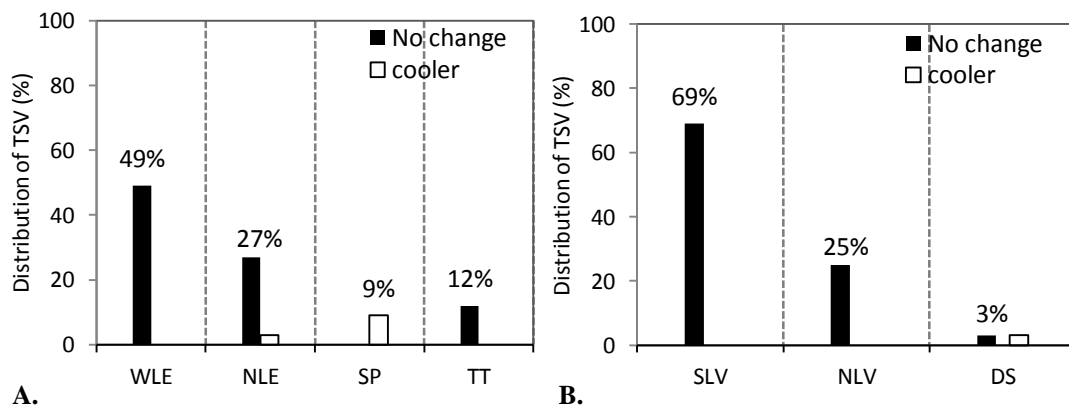

Figure 10 Percentage distribution of user's thermal preference in relation to the choice of place in (A) WE and (B) BL park

In addition all users in the place TT, the most shaded (SVF=0.27) setting in WE park informed the thermal environment is acceptable. However, it is apparent that the users in the places segregated from the water surfaces such as SP in the park WE and DS in BL park prefer cooler thermal conditions. Statistical assessment on Pearson's Chi square (χ^2) test revealed the relationship of choice of place and thermal acceptability of

the users in both parks ($P=0.000 < 0.05$) are significant. Thus the results demonstrate the influence of user expectation of choice of place on perceived control is contributing to tolerate thermally uncomfortable microclimates in both parks. Moreover, the users in hot outdoor climates could clearly differentiate the thermal preferences of the 3-point scale than expression of varying levels of hot sensations in 7-point scale.

4.2 Reasons for being in this place

This study appraised the visitor's expectation of reasons for being in different settings and its environmental attributes. Users are in these parks for three reasons such as view, shade and fresh air. These expectations are interrelated with the purpose of visiting this park and their activities. The results show they are in these parks to rest and sitting is the main activity which decides the choice of place.

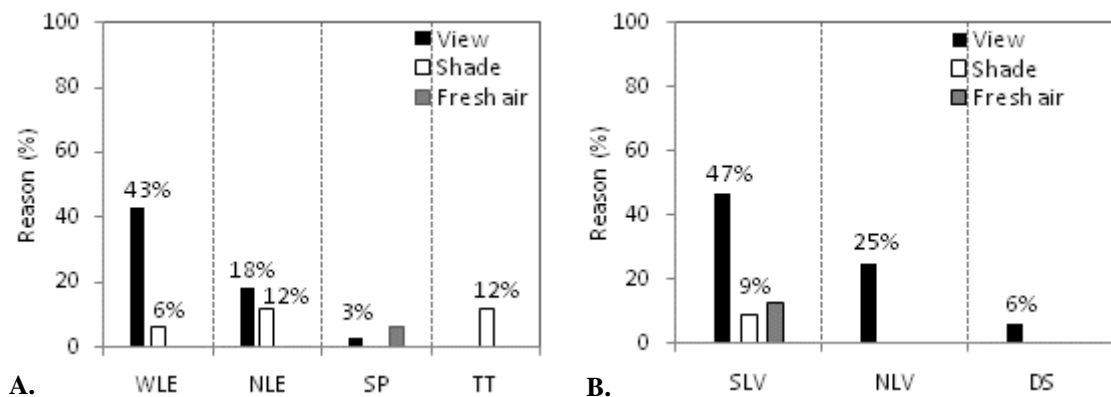

Figure 11 Percentage distributions of user's preferences on reason of being in the choice of place (A) WE and (B) BL park

Figure 11, A and B show the percentage distribution of reasons for being in the choice of place in WE and BL park respectively. View is the most influential psychological adaptation opportunity for choice of place in these study parks. Although view prioritizes the choice of place in both parks, yet 30% and 9% of the users prefer shade in the park WE and BL park respectively. However the results show except for 12% of respondents in tree trail (TT) in WE park remaining 18% is in places with moderate to low SVF within the range of 0.6 to 0.8. Pearson's Chi square (χ^2) test shows the relationship of choice of place and reason of being in the place is significant ($P=0.000 < 0.05$) in WE park. Contrary there is no significant relationship ($P=0.400 > 0.05$) for BL park.

The more naturalness of the settings with visually integrated places with water surfaces and places for shade in Water's Edge park has enhanced the environmental attributes to facilitate the expectations of its visitors.

4.2.1 Relationship of reasons and thermal acceptability

The influence of visitor's expectations for being in the place and its effect on degree of perceived control to tolerate thermally uncomfortable microclimates is presented. Figure 12, A and B show the percentage distribution of users 3-point McIntyre scale of thermal acceptability in relation to reasons for being in the place in WE and BL park respectively. 61% and 75% of the users for view expressed their actual thermal preference as 'no change' in WE and BL parks respectively. Thus the majority of the users (64% in WE and 78% in BL park) with the expectation of view in both parks and for shade (30% in WE and 9% in BL park) have informed the settings are thermally

acceptable. Pearson's Chi square (χ^2) test shows that the relationship of reason of being in the place and actual thermal acceptability is significant ($P=0.000 < 0.05$) in WE park. Contrary there is no significant relationship ($P=0.865 > 0.05$) for BL park.

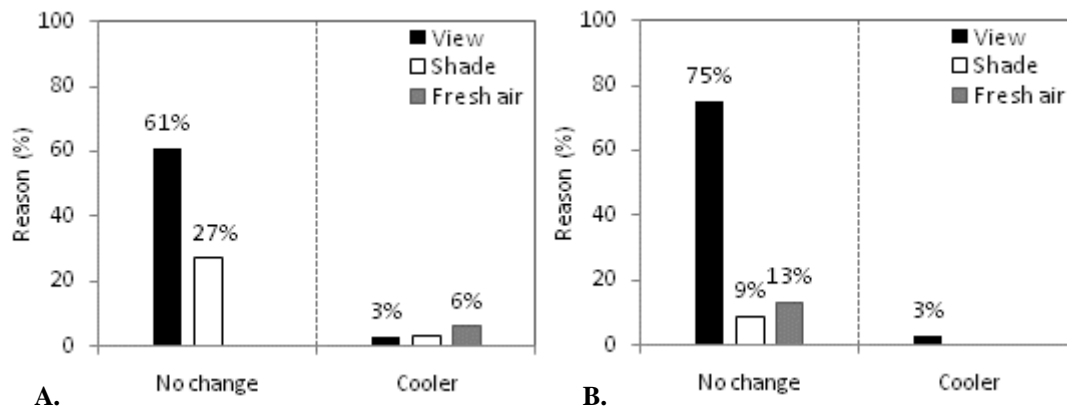

Figure 12 Percentage distribution of user's preferences on reason of being in the choice of place (A) WE and (B) BL park

Moreover the relationship of choice of place and reasons for being in the place is significant ($P=0.000 < 0.05$) in WE park and there is no significant relationship ($P=0.400 > 0.05$) in BL park. Thus the findings suggest perceived controls of visitor's vary with environmental attributes of the park. The naturalness of the settings in WE park has contributed to high degree of perceived controls of users through choice of place and satisfaction of psychological preference of view to tolerate and reduce the negative attitudes on thermally uncomfortable outdoor microclimates.

5.0 Conclusion

Appraising urban outdoor thermal environment is of prime importance to enhance urban livability and vivacity in tropics. This study explored two water fringed urban parks in Colombo to appraise the relationship of environmental attributes in facilitating visitor's perceived control for enhancing daytime thermal acceptability of extremely hot microclimates.

Seven different settings with diversified environmental attributes were identified. Microclimates of these settings were investigated using an onsite thermal experiment and simultaneous structured interview was performed for subjective assessment of thermal sensation and acceptability.

The predicted PET for microclimate of the settings is far beyond the comfortable range of thermal perception classification for subtropical climates. Also, the apparent temperature confirms thermal discomfort of settings. However, actual thermal sensation revealed 90% of local respondents expressed thermal sensation as comfortable for high PET range of 28-40°C. Thus informs the influence of environmental attributes of settings in facilitating expectations of visitor's for psychological adaptation and enhanced degree of perceived controls in tolerance of uncomfortable outdoor microclimates.

In these parks the expectations of visitor's on perceived controls are explored through their free choice of place and reasons for being in this place. The environmental attributes of the most popular settings contain visual integrations with the surrounding water surfaces. Visitor's expectation on free choice of place contributes to perceived

control and accepted hot microclimates as comfortable in the study parks. Visitors are using these parks for three major reasons such as view, shade and fresh air. View is the most preferred reason for majority of the users of these parks. However the degree of perceived control to tolerate hot microclimates is largely dependent on the naturalness of the settings and its environmental attributes.

Even though the expectation of view is the common psychological adaptation strategy for choice of place in the study parks, the potential for high degree of perceived control is intrinsic in the environmental attributes of the settings of Water's Edge park. Hence the settings with more naturalness have a greater impact on visitor's perceived controls to tolerate extremely uncomfortable outdoor microclimates of the urban parks in tropics.

These findings are extremely beneficial microclimate planning implications in urban designs for enhancing daytime vivacity and livability of tropical urban parks.

References

Ahmed KS, 2003. Comfort in urban spaces: defining the boundaries of outdoor thermal comfort for the tropical urban environments. *Energy and Buildings*, 35, 103-110.

ANSI/ASHRAE Standard 55, 2004. Thermal environmental conditions for human occupancy. *American Society of Heating, Refrigerating and Air conditioning Engineers*, Atlanta.

Fanger, PO., 1972. *Thermal comfort*. New York: McGraw Hill.

Griffiths, ID, Huber, JW and Baillie, AP, 1987. Integrating the environment, In: Steemers, TC. and Palz, W. (eds) *Proceedings of the European Conference on Architecture*, Dordrecht: kluwer Academic Publishers.

Gulyas A, Unger J, Matzarakis A, 2006. Assessment of the microclimatic and human comfort conditions in a complex urban environment: modelling and measurements. *Building and Environment*, 41: 1713-22.

Hwang RL, Lin TP, Matzarakis A, 2011. Seasonal effects of urban street shading on long-term outdoor thermal comfort. *Building and Environment*, 46:863-70.

ISO, 1998. International Standard 7726, Thermal environments - instruments and method for measuring physical quantities. *International Standard Organization* Geneva.

Kántor, N, Unger J, 2011. Benefits and opportunities of adopting GIS in thermal comfort studies in resting places: an urban park as an example. *Landscape and Urban Planning*, Volume 98, 36-46.

Katzshner L, 2011. Urban climate strategies against future heat stress conditions. In V.Olgyay (ed.), *Architecture and Climate. Manual of bioclimatic design for architects and city planners*, Princeton University Press, USA.

Katzshner L, 2006. Behaviour of people in open spaces in dependence of thermal comfort conditions, In: Compagnon, R, Haefeli, P and Weber, W. (eds) *Proceeding of 23rd Conference on Passive Low Energy Architecture*, Geneva, Switzerland, 1: 505-510.

Lenzholzer S, Koh J, 2010. Immersed in microclimatic space: microclimate experience and perception of spatial configurations in Dutch squares. *Landscape and Urban Planning*, Volume 95, 1-15.

Lin CH, Lin TP, Hwang RL, 2013. Thermal comfort for urban parks in subtropics: Understanding visitor's perceptions, behaviour and attendance, *Advances in Meteorology*, <http://dx.org/10.1155/2013/640473>.

Lin TP, Dear R de, Hwang, RL, 2011. Effect of thermal adaptation on seasonal outdoor thermal comfort. *International Journal of Climatology*, 31(2):302-12.

Lin TP, Matzarakis A, Hwang RL, 2010. Shading effect on long-term outdoor thermal comfort. *Building and Environment*, 45:213-21.

Lin TP, Matzarakis A, 2008. Tourism climate and thermal comfort in Sun Moon lake, Taiwan. *International Journal of Biometeorology*, 52:281-90.

Lin TP, Tsai KT, Liao CC, Huang YC, 2013. Effects of thermal comfort and adaptation on park attendance regarding different shading levels and activity types. *Advances in Meteorology, Building and Environment*, 59:599-611.

Lin TP, 2009. Thermal perception, adaptation and attendance in a public square in hot and humid regions. *Building and Environment*, 44, 2017-26.

Matzarakis A, Mayer H, 1996. Another kind of environmental stress: thermal stress. WHO collaborating center for air quality management and air pollution control. *Newsletters* 1996, 18:7-10.

Matzarakis A, Rutz F, Mayer H, 2007. Modelling radiation fluxes in simple and complex environments- application of the RayMan model. *International Journal of Biometeorology*, 51(4): 323-34.

Monam A, 2011. *Comfortability in urban open spaces; evaluation of outdoor thermal comfort in urban parks*. PhD. Iran university of science and technology, Tehran

Nasir et al. 2013. Psychological adaptation of outdoor thermal comfort in shaded green spaces in Malaysia, *Procedia Social and Behavioural Sciences*, 68: 875-878.

Nasir RA, Ahamad SS, Ahmed AZ, 2012. Psychological adaptation of outdoor thermal comfort in shaded green spaces in Malaysia. *Procedia-Social and Behavioural Sciences*, 68: 865-878.

Nikolopoulou M, 2004. Outdoor comfort. In: Steemers K and Steane MA, *Environmental diversity in Architecture*, UK: Spon Press.

Nikolopoulou M, Baker, N. Steemers, K. 2001. Thermal comfort in outdoor urban spaces the human parameter, *Solar Energy*, 70(3), 227-35.

Nikolopoulou M, Lykoudis S, 2007. Use of outdoor spaces and microclimate in a Mediterranean urban area. *Building and Environment*, Volume 42, 3691-707.

Nikolopoulou M., Steemers K, 2005. Thermal comfort and psychological adaptation as a guide for design for urban spaces. *Energy and Buildings*, 35:95-101.

Nikolopoulou, M, Baker N, Steemers K, 2001. Thermal comfort in urban outdoor spaces: understanding the human parameter. *Solar Energy*, Volume 70: 227-35.

Nikolopoulou, M, Lykoudis, S. Thermal comfort in outdoor urban spaces: Analysis across different European countries. *Building and Environment* 2006; 41, pp. 1455-1470.

Oliveria S, Andrade H. An initial assessment of the bioclimatic comfort in an outdoor public space in Lisbon. *International Journal of Biometeorology*, 52: 69-84.

Stathopoulos T, Wu H, Zacharias J, 2004. Outdoor human comfort in an urban climate. *Building and Environment*, 39(3): 297-305.

Steadman RG, 1984. A universal scale of Apparent Temperature. *Journal of Climate and Applied Meteorology*, 23(12):1674-1687.

Thorsson S, Lindqvist M, Lindqvist S, 2004. Thermal bioclimatic conditions and patterns of behaviour in urban park in Göteborg, Sweden. *International Journal of Biometeorology*, 48, 149-56.

Toudert A F, Mayer H 2007. Thermal comfort in an east-west oriented street canyon in Freiburg (Germany) under hot summer conditions. *Theoretical and Applied Climatology*, 87:223-37.

Xu J, Wei Q, Huang X, Zhu X, Li G, 2010. Evaluation of human thermal comfort near urban water body during summer, *Building and Environment*, 45:1072-80.

Investigation of the outdoor thermal comfort and clothing insulation in Hachiko Square in Tokyo

Genki Hoshino¹ and Hom B. Rijal²

¹*Department. of Environmental and Information Studies, Tokyo City University, Japan*

²*Department. of Restoration Ecology & Built Environment, Tokyo City University, Japan*

¹g1131180@tcu.ac.jp

²rijal@tcu.ac.jp

Abstract

In order to clarify the outdoor thermal comfort and clothing, the thermal measurements (air temperature) and thermal comfort survey were conducted in Hachiko Square which is located in the Shibuya station, Tokyo. (Hachiko is a famous statue of a dog which is a popular meeting place.) The survey was conducted every two weeks and the number of people investigated was 224. The results showed that the average clothing insulation of the females is greater than that of the men. The clothing insulation is highly correlated with the outdoor air temperature. The equation can be used to predict the degree of clothing insulation in outdoor spaces.

Keywords: Clothing insulation; Outdoor air temperature; Outdoor thermal comfort

1. Introduction

People use outdoor spaces for various activities, such as relaxing, meeting people, taking short breaks and playing. If the outdoor environment is well-designed and thermally comfortable, people use it regularly in their daily life. However, we often encounter uncomfortable outdoor environments which need improving by optimizing shading, greenery, open spaces etc. Because of seasonal and regional adaptation, people may have different thermal expectations of the outdoor environment, which might be an important factor in explaining outdoor thermal comfort. How people adapt to various outdoor conditions is not yet fully understood. Generally, people feel comfortable in outdoor space by adjusting their clothing. They choose and wear the most comfortable clothing to suit their various thermal situations. People are free to adjust the clothing outdoors, and thus they might be adapting well compared to within the office buildings context. Up to date, there are many research papers on clothing in indoor environments [1-8]. However, there is only a limited amount of research on clothing in outdoor environments and conducted only for a short period of time [12, 13, 17].

In order to clarify the outdoor thermal comfort and clothing, thermal measurements and a thermal comfort survey (thermal sensation, thermal preference and clothing insulation) were conducted in Hachiko Square in Tokyo.

2. Research methods

The survey was conducted in the Hachiko square which is located by Shibuya station, Tokyo. The survey was conducted every two weeks and the number of investigated people was 224

(male = 162, female = 62). The mean age of these participants was 31 years old (male = 33 years, female = 30 years).

The Investigation period was 29th September to 2nd December 2013 and the investigative time was 12:00 to 20:00. The outdoor air temperature was measured by a compact measuring device around the people. In the thermal comfort survey, thermal sensation (7 point scale), thermal preference (5 point scale) and clothing insulation were included (Table 1).

The clothing insulation was recorded by two methods: summation method and illustration method. The summation method is the conventional method where the clothing insulation was summed up by recording each items of clothing. In the “illustration method”, the clothing insulation was chosen from the nearest figure (Figure 1).

Table 1: Thermal sensation and thermal preference scale.

	Thermal sensation	Thermal preference
No.	How do you feel the temperature of the now?	Do you want how the temperature of the now?
1	Very cold	Much warmer
2	Cold	A bit warmer
3	Slightly cold	No change
4	Neutral (neither hot nor cold)	A bit cold
5	Slightly hot	Much cold
6	Hot	
7	Very hot	

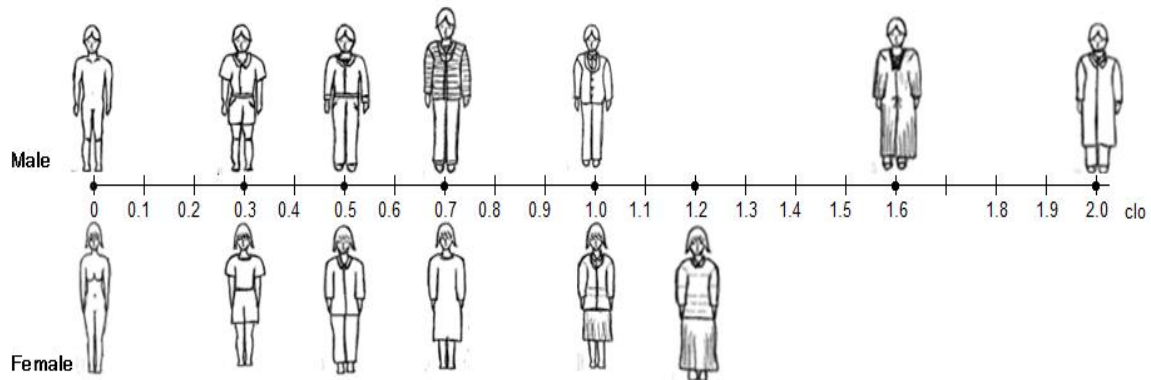

Figure 1: Scale of the clothing insulation for illustration method.

3. Results and discussion

3.1 Outdoor air temperature

The daily mean outdoor temperature during the voting is shown in Table 2. The mean outdoor temperature in autumn is about 10 °C higher than in winter.

Table 2: Average outdoor temperature of the day.

Date	Season	Number of data	Outdoor air temperature (°C)		Thermal sensation		Thermal preference	
			Mean	SD	Mean	SD	Mean	SD
2013/9/29	Autumn	39	22.6	1.3	3.8	0.7	2.9	0.6
2013/10/8	Autumn	65	27.5	1.2	4.8	0.8	3.6	0.7
2013/11/11	Autumn	18	15.2	3.0	2.6	1.2	1.9	1.1
2013/11/28	Autumn	41	14.5	2.2	2.6	0.9	2.2	1.0
2013/12/2	Winter	61	14.6	0.5	3.0	0.9	2.7	0.6

SD : Standard deviation

3.2 Distribution of thermal sensation

The mean thermal sensation vote is shown in Table 2. The percentage of thermal sensation is shown in Table 3. The most common thermal sensation vote is “4 neutral” (33.5%). The proportion of thermal sensation in cold side (1 very cold to “3 slightly cold”) is 45%. This might be due to the low outdoor air temperature in winter.

Table 3: Percentage of the thermal sensation.

Scale	Number of data	Percentage (%)
1	7	3.1
2	46	20.5
3	48	21.4
4	75	33.5
5	33	14.7
6	14	6.3
7	1	0.4
Total	224	100.0

3.3 Distribution of thermal preference

The mean thermal preference vote is shown in Table 2. The percentage of thermal preference is shown in Table 4. The most common thermal preference is “3 no change” (53.1%). If we count the vote “1 much warmer” and “2 a bit warmer”, it would be 27.7%.

Table 4: Percentage of the thermal preference.

Scale	Number of data	Percentage (%)
1	25	11.2
2	37	16.5
3	119	53.1
4	34	15.2
5	9	4.0
Total	224	100.0

3.4 Relation between the thermal preference and thermal sensation

Figure 2 show the relation between the thermal preference and thermal sensation. They are highly correlated, and thus two scales are well matched.

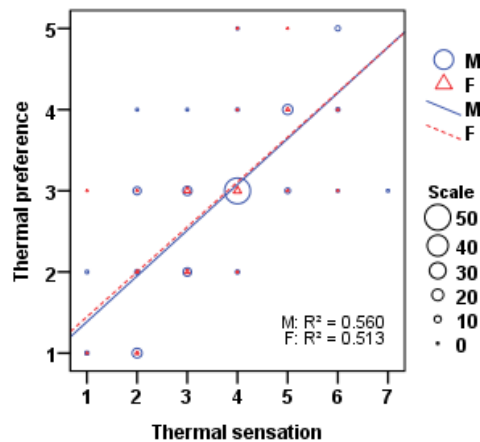

Figure 2: Relation between the thermal preference and thermal sensation.

3.5 Relation between the outdoor air temperature and thermal sensation

Figure 3 shows the relation between the thermal sensation and outdoor air temperature. They are highly correlated. We have found the following regression equation to predict the outdoor comfort temperature.

$$\text{All: } C = 0.157T_o + 0.462 \quad (n=224, R^2=0.56, p<0.001) \quad (1)$$

$$\text{M: } C = 0.160T_o + 0.435 \quad (n=162, R^2=0.55, p<0.001) \quad (2)$$

$$\text{F: } C = 0.149T_o + 0.521 \quad (n=62, R^2=0.58, p<0.001) \quad (3)$$

C : thermal sensation, T_o : outdoor air temperature ($^{\circ}\text{C}$), n : number of samples, R^2 : coefficient of determination, p : significance level.

When the comfort temperature is predicted by substituting “4 neutral” in the equations (1) to (3), the comfort temperature would be 22.5°C (male = 22.2°C , female = 23.3°C). The comfort temperature of the female is slightly higher than the male.

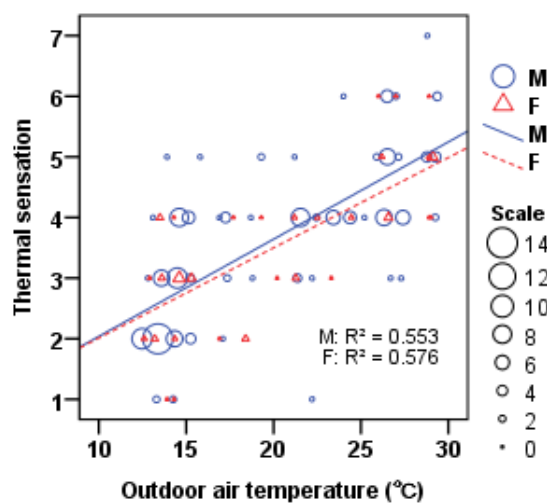

Figure 3: Relation between the thermal sensation and the outdoor air temperature.

3.6 Distribution of clothing insulation

Table 5 shows the mean clothing insulation. The clothing insulation of the “summation method” is slightly higher than that of the “illustration method”. Table 6 shows the comparison of the clothing insulation with the previous research. The clothing insulation of this research is comparable to the previous research. In most research, the clothing insulation of female is higher than male. The reason might be that female are more sensitive to temperature changes than male.

Table 5: Daily mean clothing insulation.

Date	Number of data	Illustration method (clo)		Summation method (clo)	
		Mean	SD	Mean	SD
2013/9/29	39	0.6	0.30	0.7	0.20
2013/10/8	65	0.5	0.19	0.6	0.13
2013/11/11	18	0.7	0.17	1.0	0.27
2013/11/28	41	0.9	0.31	1.3	0.26
2013/12/2	61	0.9	0.33	1.4	0.34

SD : Standard deviation

Table 6: Comparison with the previous research.

No.	Reference	Region	Place	Year	Month	Method	Clothing insulation (clo)		
							Mean	Male	Female
1	This research	Tokyo	Outdoor	2013	10~12	Illustrations method	0.63	0.62	0.69
						Summation method	0.83	0.83	0.85
2	Ooi et al. ¹⁰⁾	Fukuoka	Outdoor	1998	11	Summation method	1.03	-	-
3	Ooi et al. ¹¹⁾	Fukuoka	Outdoor	1998	11	Summation method	1.08	1.11	1.06
4	Shirono et al. ¹²⁾	Fukuoka	Outdoor	1999	11	Summation method	-	0.98	0.90
5	Shirono et al. ¹³⁾	Fukuoka	Outdoor	1999	11	Summation method	0.98	0.90	0.95
6	Yasui et al. ¹⁴⁾	Okinawa	Outdoor	2000	10~12	Summation method	-	0.59	0.61
7	Yasui et al. ¹⁵⁾	Okinawa	Outdoor	2000	10~12	Summation method	-	0.59	0.60
8	Yasui et al. ¹⁶⁾	Okinawa	Outdoor	2000•2001	10~12	Summation method	0.67	-	-
9	Nakamatsu et al. ¹⁷⁾	Okinawa	Outdoor	2000•2001	10~12	Summation method	-	0.60	0.70
10	Nakamatsu et al. ¹⁸⁾	Okinawa	Outdoor	2000•2001	10~12	Summation method	-	0.57	0.67
11	Suzuki et al. ¹⁹⁾	Aichi	Outdoor	2002	10~12	Summation method	1.41	-	-
12	Noguchi et al. ²⁰⁾	Tokyo	Semi	2002~2003	10~1	Summation method	1.00	-	-

3.7 Relation between the “illustration method” and the “summation method”

Figure 4 shows the relation between “illustration method” and “summation method”. The clothing insulation of the “summation method” is greater than that of the “illustration method”.

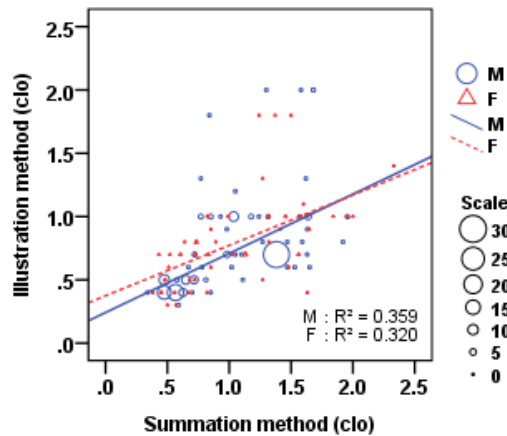

Figure 4: Relation between the “illustration method” and “summation method”.

3.8 Relation between the clothing insulation and the thermal sensation

Figure 5 shows the relation between the clothing insulation and thermal sensation. They are negatively correlated. The results showed that people adapt to outdoor environments by changing their clothing.

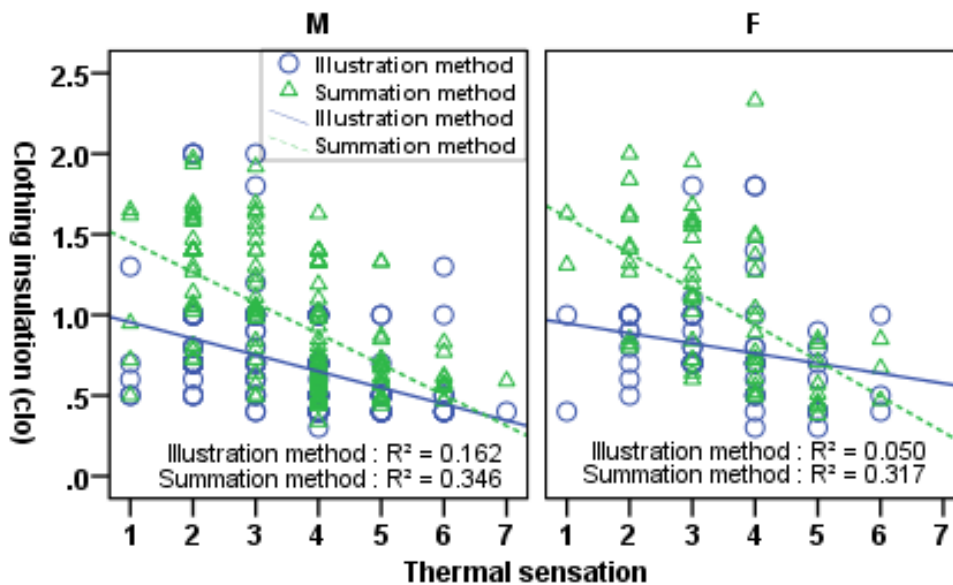

Figure 5: Relation between the clothing insulation and thermal sensation.

3.9 Relation between the clothing insulation and the outdoor air temperature

To predict the clothing insulation, figure 6 shows the relation between the clothing insulation and the outdoor air temperature. They are negatively correlated. We have the following regression equation.

Illustration method

$$\text{All: } I_{cl} = -0.028T_o + 1.268 \quad (n=224, R^2=0.26, p<0.001) \quad (4)$$

$$\text{M: } I_{cl} = -0.027T_o + 1.227 \quad (n=162, R^2=0.25, p<0.001) \quad (5)$$

$$\text{F: } I_{cl} = -0.030T_o + 1.384 \quad (n=62, R^2=0.30, p<0.001) \quad (6)$$

Summation method

All: $I_{cl} = -0.055T_o + 2.072$ (n=224, $R^2=0.58$, $p<0.001$) (7)

M: $I_{cl} = -0.054T_o + 2.026$ (n=162, $R^2=0.60$, $p<0.001$) (8)

F: $I_{cl} = -0.058T_o + 2.200$ (n=62, $R^2=0.56$, $p<0.001$) (9)

I_{cl} is the clothing insulation. If we substitute the 15 °C in in these equations, the clothing insulation for “illustration method” is 0.85 clo (male = 0.72 clo, female = 0.93 clo). Similarly, as for the “summation method”, it would be 1.25 clo (male = 1.22 clo, female = 1.33 clo).

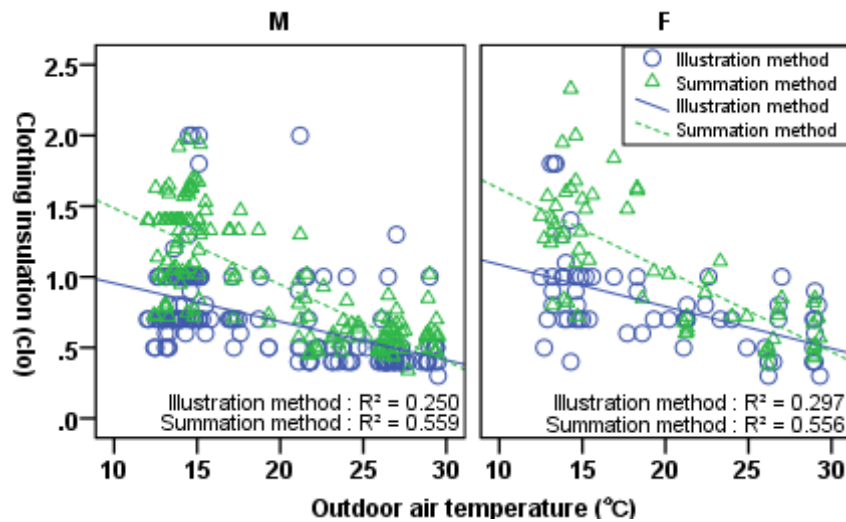

Figure 6: Relation between the clothing insulation and the outdoor air temperature.

To investigate the regression coefficient and coefficient of determination of the raw data, figure 7 shows the relation between the mean clothing insulation and the mean outdoor air temperature. Each point is the daily mean value. The regression lines of the average data are very similar to the raw data (Figs. 6 and 7). However, the coefficient of determination is significantly higher in the averaged data.

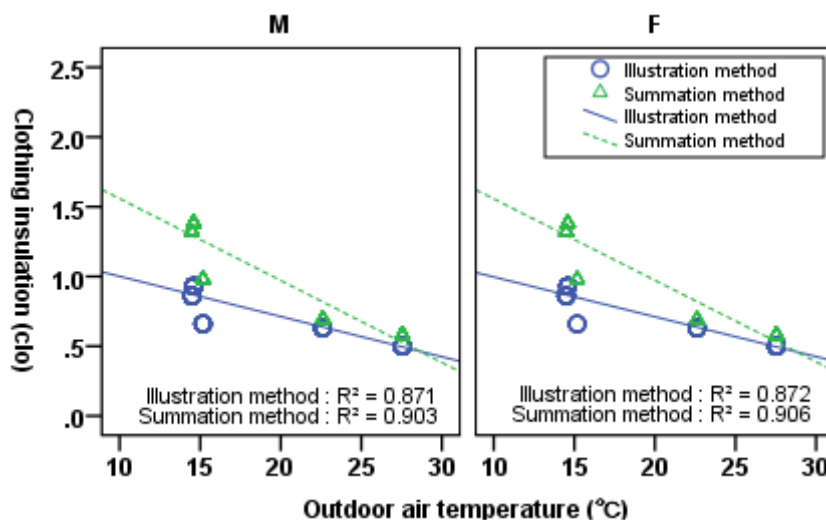

Figure 7: Relation between the clothing insulation and the outdoor air temperature.

4 Conclusions

In this research, we have conducted the thermal measurements and thermal comfort survey in Hachiko Square in Tokyo, and the following results were obtained.

1. The clothing insulation of the female is higher than the male.
2. The clothing insulation of the “summation method” is higher than the “illustration method”.
3. The relation between the clothing insulation and the thermal sensation is negatively correlated. The results showed that people adapt to outdoor environments by changing their clothing.
4. The relation between the clothing insulation and the outdoor air temperature is negatively correlated, and thus the clothing insulation can be predicted by outdoor temperature.

Acknowledgements

We would like to give thanks to all people who took part in the survey.

References

1. Ishino H., Kohri K. and Sato Y. (1997), A study on the use of office space affecting air-conditioning load. *Journal of Architectural Planning and Environmental Engineering, AIJ, 500*, pp. 31-36. (In Japanese)
2. Nishihara N., Haneda T., Nakamura S. and Tanabe S. (2008), Effect of indoor environment quality on productivity (Part 20): Field Survey of Workers Clothing Habit in the COOLBIZ Office. *Architectural Institute of Japan*, pp. 1127-1128. (In Japanese)
3. Ihara T., Ishii A., Saito M. and Oi H. (2000), Subject experiment about the clothes and thermal environment evaluation in the outdoors. *Architectural Institute of Japan, AIJ, 39*, pp. 365-368. (In Japanese)
4. Tomita A. and Kato T. (2007), A study on clothing ensembles and thermal sensations of the elderly women in outdoor environment. *Journal of Sugiyama Women School University Research, AIJ, 38*: p. 9-19. (In Japanese)
5. Nakamatsu R., Tsutsumi J, Arakawa R., Yasui F., Saito M. and Ishii A. (2003), Field surveys on clothing levels as one of the control factors for thermal sensation in subtropical Okinawa. *Journal of Environmental Engineering, AIJ, 570*, pp. 21-27. (In Japanese)
6. Yamato Y., Matsubara M. and Kurazumi Y. (2005), Investigation on residents clothes in and around Kyoto city. *Journal of Environmental Engineering, AIJ, 595*, pp. 25-31. (In Japanese)
7. Hukusaka M. and Matsubara N. (2006), Investigation of the residents clothing levels and life of indoor in Kinki and Chubu region. *Architectural Institute of Japan*, pp. 783-784. (In Japanese)
8. Ookuma R., Ishino H. and Nakayama S. (2008), Clothing and thermal comfort at 28 °C of air temperature in winter. *Journal of Environmental Engineering, AIJ, 73*, pp. 307-312. (In Japanese)
9. ISO2003 : ASHRAE Standard 55 (1992), Thermal Environmental Conditions for Human occupancy, *ANSI/ASHRAE 55-1992*.
10. Oi H., Ishii A. and Saito M. (1999), Questionnaires on Clothing Ensembles in the Outdoor Environment. *AIJ - China*, pp. 401-402 (In Japanese)
11. Oi et al. (1999.3), *AIJ - Kyusyu Vol. 38*, pp. 353-356 (In Japanese)
12. Jono et al. (2000), *AIJ - Kyusyu Vol. 39*, pp. 357-360 (In Japanese)
13. Jono O., Ishii A., Saito M. and Oi H. (2000), Questionnaires on Clothing Ensembles in

- the Outdoor Environment. Part 2: Clothing Insulation characteristics by age, gender and occupation based on annual surveys. *AIJ – Tohoku*, pp. 423-424 (In Japanese)
14. Yasui F., Tsutsumi J., Arakawa R., Nakamatsu R., Ahmed S., Ishii A. and Saito M. (2001), Survey on clothing level and thermal sensation. *AIJ – Kanto*, pp. 385-386 (In Japanese)
 15. Yasui et al. (2001), *AIJ – Kyusyu*, Vol. 40, pp. 305-308 (In Japanese)
 16. Yasui F., Tsutsumi J., Arakawa R., Nakamatsu R., Kinjyo Y., Yajima K., Ishii A. and Saito M. (2002), Surveys on clothing level and thermal sensation in outdoor spaces. *AIJ – Kyusyu*, Vol. 41, pp. 197-200 (In Japanese)
 17. Nakamatsu R., Tsutsumi J. and Arakawa R. (2003), Field Survey on Clothing Levels of Outdoor Thermal Environment in Okinawa. *AIJ – Tokai*, pp. 519-520 (In Japanese)
 18. Nakamatsu R., Tsutsumi J., Arakawa R., Ishii A. and Saito M. (2003), Measurement of Clothing Levels and The Multi Regression Equation to Predict Clothing Levels in Subtropical Okinawa. *AIJ - Kyusyu Vol. 42*, pp. 309-312 (In Japanese)
 19. Suzuki S., Watanabe S. and Noda A. (2004), Relationship between thermal insulation value of clothing and air temperature indoor and outdoor. *AIJ - Tokai Vol. 42*, pp. 465-468 (In Japanese)
 20. Noguchi et al. (2003), Seasonal Field Survey on Thermal Comfort Conditions in Semi-Outdoor Spaces. Part 8: Outline of the Field Survey in Semi-Outdoor and Indoor Spaces. *AIJ – Tokai*, pp. 527-528 (In Japanese)

Analyzing night time wind speed reduction effects from densification on predicted outdoor thermal comfort in a subtropical setting

Eduardo Krüger¹ and Peter Bröde²

1 Technological University of Parana, Brazil, ekruger@utfpr.edu.br

2 IfADo - Leibniz Research Centre for Working Environment and Human Factors, Dortmund, Germany broede@ifado.de

Abstract

The relationship between urban growth and the formation of urban heat islands, i.e. climatic differences between the urban area and adjacent rural areas, is discussed by several authors and is assumed to be ubiquitous for various climatic regions. Curitiba (25.5°S), located within a region of subtropical climate in elevation, boasts a population growth rate of approximately 2% a year. The purpose of this study is to evaluate the effect of the urban agglomeration on microclimate changes. From comprehensive long-term climate data monitoring carried out during 2011-2013 with a pair of weather stations in and outside the urban area, outdoor thermal comfort conditions are assessed by means of the UTCI index, which had been calibrated to local thermal preferences in a previous study. Comparisons between urban and rural conditions are shown as traditional Urban Heat Island (UHI) results as well as in terms of predicted comfort/discomfort levels. A projection to a more densified condition is performed by significantly reducing air speed at night. We discuss obtained results in predicted thermal comfort variations against current conditions.

Keywords: Urban Heat Island, outdoor thermal comfort, wind speed, UTCI.

1 Introduction

In tropical regions, urbanization rates tend to be the highest: the average annual rate of change of the urban population for the 5-year period 2005-2010 was just over three times higher in the less developed regions than in the more developed regions of the world, following a rising trend (United Nations 2012). As a consequence of such urban growth local climate conditions can be highly affected, which can have an impact on overall energy consumption in buildings due to unintended Urban Heat Island (UHI) effects.

In tropical areas the formation of UHI associated with climate change can bring about serious consequences, thus UHI mitigation should be part of present and future urban planning strategies. Compared to other developing countries, Brazil has a significant urban population (approximately 85%), surpassing the average urban percentage in developed countries (United Nations 2012). As a consequence, major Brazilian cities like São Paulo have reported UHI intensities in some instances reaching 10°C in the most polluted and densified areas of the megalopolis (Lombardo 1985).

Curitiba, where the present study was carried out, has a long tradition in urban planning since the 1940's. However, urban planning strategies proved to be quite limited to cope with numerous socio-environmental problems arising from uncontrolled urban growth: irregular

occupations near water sources, increasingly frequent floods, pollution, among other effects. Curitiba's spatial configuration is characterized today mainly by massive vertical axes along the so called 'structural sectors', with an impact on the urban landscape and aspects related to environmental comfort; buildings in such urban canyons are affected thermally (Krüger et al. 2011), by the lack of daylight (Krüger and Suga 2009), by changes in ventilation patterns with effects on air quality (Krüger et al. 2011).

The purpose of this paper is thus to evaluate inadvertent effects from urbanization on predicted outdoor thermal comfort levels and those resulting from reduced wind speeds during night time.

2 Method

Curitiba (25°25'50" S, 49°16'15" W, 917 m elevation) is located in southern Brazil, with a present population reaching 2 Million inhabitants. It has a long tradition in urban planning, being famous mostly for its innovative mass transportation system (tube stations). With regard to local climate, average temperatures in summer range 17-20°C and in winter 12-14°C. Annual average temperature is about 16°C. Daily amplitudes may vary between 0.5 and 25.7 °C, and the average swing is 10.5 °C. Absolute humidity ranges between about 4 to 18 g·kg⁻¹, with an average of about 11 g·kg⁻¹. Annual precipitation is around 1600 mm.

Comprehensive long-term climate monitoring was carried out during 2011-2013 with a pair of weather stations in and outside the urban area. Climatic data were collected at two different locations: at the official meteorological station 'SIMEPAR', at the Polytechnic Center (assumed to be an 'urban' station) and at the Campus Ecoville of the Federal Technological University of Paraná (assumed as "rural"). The approximate distance between the two stations is 12 km. Variables monitored comprise air temperature and humidity, global solar radiation and wind speed. "Ecoville Weather Station" is located on the outskirts of the urban area and on the roof top of a three-storey campus building with no noticeable obstructions to wind and solar radiation. Adjustments were made only to measured wind speed so that the same height is considered for both stations (10 m) when applying the UTCI index. The monitoring period extends from December 2011 to February 2013. Only data for 2012 were used in this paper, as shown in Table 1, with the various seasons. From this set of data, a standard Urban Heat Island (UHI) analysis was initially performed, which was based on the assessment of air temperature differences between sites (urban-rural) during night time.

Table 1: Monitoring periods, divided in seasons

Period	YD	N (days)
Entire Period	1-365	326
Summer	1-79,355-365	87
Fall	80-171	66
Winter	172-263	82
Spring	264-354	91
Missing data	24,25,51,146-181	39

2.1 Thermal comfort assessment with UTCI

The Universal Thermal Climate Index (UTCI) was used for assessing the predicted thermal sensation under different conditions. UTCI aims at the assessment of the outdoor thermal conditions in the major fields of human biometeorology by a one-dimensional quantity

summarizing the interaction of the basic thermal variables (air temperature, wind speed, humidity, radiant fluxes) on an equivalent temperature scale ($^{\circ}\text{C}$). This assessment is based on an advanced multi-node model of human thermoregulation (Fiala et al. 2010, Fiala et al. 2012) coupled with a state-of-the-art clothing model (Havenith et al. 2012).

Input parameters for assessing UTCI at both sites were: measured air temperature; deviation of the mean radiant temperature to ambient temperature (ΔT_{mrt}); relative humidity or water vapour pressure; and wind speed at 10 m above the ground, which was adjusted, when needed, from onsite measurements at x m using a logarithmic scale factor $\log(10/0.01)/\log(x/0.01)$ as in Bröde et al. (2012).

In a previous paper (Rossi et al. 2012) we calibrated UTCI comfort/discomfort ranges for Curitiba, from surveys conducted with local population. In structured interviews, passers-by on a pedestrian street in Curitiba provided information on their weight, height, age and gender, on their clothing as well as on their thermal sensation, affective evaluation, thermal preference and thermal tolerance using standardized scales (ISO 1995). Concurrent measurements of air temperature and humidity, globe temperature and wind speed were performed in parallel to the interviews and were used to calculate actual UTCI values. Thermal sensation responses were grouped into three categories: (1) 'cold discomfort' (thermal sensation votes -3 and -2), (2) 'neutral / comfortable' (votes -1, 0 and +1), (3) 'heat discomfort' (thermal sensation votes +2 and +3). By means of regression analysis and comparisons of actual thermal responses against UTCI estimates, it was found that the comfort range for the sample was 15-27 $^{\circ}\text{C}$ (UTCI); UTCI values lower than that range were assumed to be in cold stress and higher than 27 $^{\circ}\text{C}$ (UTCI) in heat stress.

Hourly values of the UTCI equivalent temperature were obtained for the monitored climatic conditions by the table-lookup approach utilizing interpolation of pre-calculated UTCI values as described in Bröde et al. (2012). Measured variables at both sites were used directly except for the wind speed at the "Ecoville Weather Station", which was scaled to the height of 10 m for UTCI calculations as described above. The mean radiant temperature, for both locations, was obtained by the estimation of that parameter with RayMan (Matzarakis et al. 2010) using local global horizontal radiation.

2.2 Assessing outdoor comfort effects with reduced wind speed

In more constrained conditions (even though the 'urban' location was central, it is a meteorological site thus presenting no noticeable wind-blocking obstacles in the surroundings), the effect of roughness on wind speed patterns will play a role in overall comfort conditions; moreover the existence of buildings will also have an impact on radiant heat loads within urban canyons (Matzarakis and Endler 2010). The convective and radiant effects from an increased densification will thus significantly alter thermal comfort/discomfort differences between such location and the rural site. To account for such effects during night time periods, a simple exercise was carried out consisting of modifying wind speed according to an increased roughness at the urban site. This exercise doesn't take into account any consequences from shading/heat gains in urban canyons, which would have altered the mean radiant temperature during the day, or any heat trapping effects from increased thermal mass by buildings during night time.

Measured wind speed at the urban site (U) was modified according to a power law equation (Allard 1997):

$$\frac{U}{U_{10}} = Kz_1^a \quad (\text{Eq.1})$$

where the coefficient K and the exponent a are given as a function of roughness characteristics of the site (for ‘City’ conditions, $K=0.21$ and $a=0.33$); z_1 is the measurement height (10 m) and U_{10} is the wind speed measured at the met site.

UTCI predictions were made using modified wind speed for the urban measurement site, which were subsequently compared to the original UCI predictions (with wind speed as measured at the urban site).

3. Results

3.1 Urban heat island effects

The urban heat island is a nocturnal phenomenon which usually takes place after sunset on clear days with low wind speed. Its maximum intensity, expressed as temperature difference between a rural, reference site and an urban counterpart, occurs a few hours after sunset. Table 2 shows results in terms of maximum heat island intensity during night time ($\Delta T_{u-r(\max)}$) and average intensity, averaged for each period of analysis. The mean UHI intensity is highest during summer. Although it is very similar to fall and spring periods, it almost doubles the winter intensity. However the mean maximum intensity is stronger in winter, as during this season the frequency of clear sky days is somewhat higher in Curitiba.

Table 2: Maximum heat island intensity ($\Delta T_{u-r(\max)}$) and average UHI intensity (for night time hours, in °C)

Period	Mean heat island intensity ($\Delta T_{u-r(\text{avg})}$)	Maximum heat island intensity ($\Delta T_{u-r(\max)}$) – averaged over the period
Entire Period	0.53	1.54
Summer	0.61	1.39
Fall	0.58	1.59
Winter	0.34	1.71
Spring	0.60	1.49

3.2 Effect on predicted thermal comfort percentages

Table 3 shows average differences in UTCI units for urban against rural conditions (ΔUTCI_{u-r}), for night time and for all periods.

Although differences are small, slightly highest UTCI variations are found for the summer night time hours. Considering UTCI comfort ranges during night time, virtually no night time in ‘heat’ category are found; UTCI averages, even for summer, lie within the calibrated comfort range (15-27°C UTCI) or lower than that. Mean percentage distributions of night time hours in cold stress are shown in columns 2 to 4 of Table 4.

As expected, percent rates in cold stress are the lowest for summer and higher for fall and winter. It can be noticed that percent changes in predicted cold stress due to urbanization are higher in summer and lower for the other seasons, which could suggest that the rural site and areas on the outskirts may benefit from “cooler” nights in summer. In terms of outdoor comfort this is accompanied by a reduction of comfort hours; however, within buildings, living outside the urban area could mean less heat stress during night time, therefore

improving sleep quality. On the other hand, urbanization effects in winter are less evident (4% decrease in cold stress).

Table 3: Variations in terms of UTCI and average differences between urban and rural conditions (Δ UTCI_{u-r}) (for night time hours, in °C)

Period	UTCI_rural (avg)	UTCI_urban (avg)	Δ UTCI _{u-r} – averaged over the period
Entire Period	12.9	13.9	1.0
Summer	16.2	17.3	1.1
Fall	12.1	13.1	1.0
Winter	10.0	10.7	0.7
Spring	12.9	13.9	1.0

Table 4: Percent rates in cold stress for night time hours – present conditions and with reduced wind speed

Period	rural	urban	% changes	urban (low wind speed)	% changes (low wind speed)
Entire Period	63	55	-8	43	-20
Summer	34	21	-13	7	-27
Fall	77	70	-7	56	-21
Winter	88	83	-4	75	-12
Spring	59	52	-7	38	-21

3.3 Predicted effects for more densified conditions during night time

As results shown previously for the urban site refer to data collected at a meteorological station with no significant obstructions, we performed UTCI simulations for outdoor conditions with diminished wind speed as a surrogate of more constrained urban conditions. Figure 1 shows percent rates in cold stress and comfort for the urban site, allowing a first-hand comparison between actual conditions against of those resulting from a rougher urban morphology. Cold discomfort during night time, shown in terms of percent rates, suggest an exacerbated picture of the present situation, which could correspond more closely to those of nearby built-up areas. A reduction in time percent rates in cold can be as much as 27% for the more densified urban site (Table 4, columns 5 and 6). As a matter of fact, not far from the urban site (meteorological station), within a 5-km distance, lies the “Structural Sector” of the city¹, which allows verticalization and high-rise buildings resulting in reduced wind speed profiles.

¹ Those “structural axes” present no height restrictions to buildings. Through such street canyons, the most intense vehicular traffic flows towards the city center. The Structural Sector congregates three distinct and inseparable functions: to serve as important traffic routes, to support the existent mass transportation system and to function as a means of controlling land use (Krüger and Suga 2009).

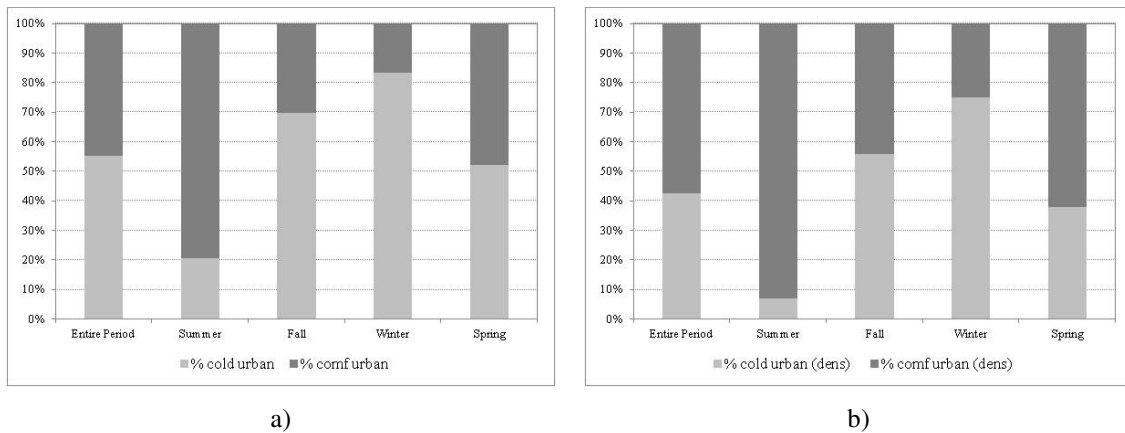

Figure 1: Percent change rates in cold/comfort for the urban site: a) from measured data; b) from modified wind speed (urban – rural)

4. Conclusions

The underlying motivation for this study was to evaluate whereas the urbanization process and the intensification of the urban heat island as one of its inadvertent impacts is beneficial to Curitiba in the colder part of the year, taking into account its status as the “coldest capital of Brazil”. Local climate is characterized by cold spells in winter which are responsible for extreme cold discomfort in dwellings (Krüger and Dumke 2001), furthermore the use of heating devices is not customary. Analysis of year-long air temperature monitoring data at two sites with significant differences in urbanization levels shows a small nocturnal heat island effect with weak differentiation over the seasons. The combined effect of climatic variables measured at the two sites as a single UTCI unit yielded again negligible seasonal differences. However, percent rate changes of night time hours in thermal stress due to urbanization effects were found to be significantly higher in summer than in other parts of the year. In a similar study, Matzarakis and Endler (2010) argue that in cities changes in terms of temperature can be less significant as changes in outdoor comfort index results.

The assumption of diminished wind speeds during night time to account for a more constrained urban morphology enhanced even more discrepancies in percent rates in cold stress at the urban area relative to the rural site. The impact of the UHI in summer was found to be as much as three times larger than in winter for the present situation; for reduced wind speed this relationship drops to a factor of two. The implications of this effect are that, in households located in downtown Curitiba, heat discomfort in summer can be become more hazardous than a reduction of cold hours in winter; in addition, users’ adaptation measures can be more effectively implemented in winter (by e.g. increasing internal heat loads) than in summer (as ventilation potential is generally lower during night time).

References

- Allard F (1998). *Natural Ventilation in Buildings: A Design Handbook*, James & James Ltd.
- Bröde P, Fiala D, Blazejczyk K, Holmér I, Jendritzky G, Kampmann B, Tinz B, Havenith G (2012). Deriving the Operational Procedure for the Universal Thermal Climate Index UTCI. *Int J Biometeorol* 56(3):481-494.
- Fiala D, Havenith G, Bröde P, Kampmann B, Jendritzky G (2012). UTCI-Fiala multi-node model of human heat transfer and temperature regulation. *Int J Biometeorol* 56(3):429-41.

Fiala D, Psikuta A, Jendritzky G, Paulke S, Nelson DA, Lichtenbelt WD, Frijns AJ (2010). Physiological Modeling for Technical, Clinical and Research Applications. *Frontiers in Bioscience* Vol. S2:939-968.

Havenith G, Fiala D, Blazejczyk K, Richards M, Bröde P, Holmér I, Rintamäki H, Benschabat Y, Jendritzky G (2012). The UTCI-clothing model. *Int J Biometeorol* 56(3):461-470.

INTERNATIONAL ORGANIZATION FOR STANDARDIZATION. ISO 10551: *Ergonomics of the thermal environment – Assessment of the influence of the thermal environment using subjective judgement scales*. Geneva. 1995.

Krüger EL, Dumke EMS (2001). Thermal performance evaluation of the Technological Village of Curitiba - Brazil. *PLEA 2001 Conference Proceedings*. Florianópolis, Brazil.

Krüger EL, Suga M (2009). Thermal and daylighting evaluation of the effect of varying aspect ratios in urban canyons in Curitiba, Brazil. *Journal of Renewable and Sustainable Energy* 1: 033108.

Krüger EL, Minella FO, Rasia F (2011). Impact of urban geometry on outdoor thermal comfort and air quality from field measurements in Curitiba, Brazil. *Build Environ* 46(3): 621 - 634.

Lombardo MA (1985). *Ilha de Calor nas Metrôpoles: o exemplo de São Paulo*. São Paulo: Ed. Hucitec.

Matzarakis A, Endler C (2010). Climate change and thermal bioclimate in cities: impacts and options for adaptation in Freiburg, Germany. *Int J Biometeorol* 54:479-483.

Matzarakis A, Rutz F, Mayer H (2010). Modelling radiation fluxes in simple and complex environments: basics of the RayMan model. *Int J Biometeorol* 54: 131-139.

Rossi FA, Krüger EL, Bröde P (2012). Definição de faixas de conforto e desconforto térmico para espaços abertos em Curitiba, PR, com o índice UTCI. *Ambiente Construído* 12: 41-59.

Szokolay SV (1983). *Arquitetura Solar: Realización y Proyectos a Escala Mundial*. Editorial Blume. Barcelona.

United Nations, Department of Economic and Social Affairs, Population Division (2012). *World Urbanization Prospects: The 2011 Revision, CD-ROM Edition*.

For books: Author, Initials., Year. *Title of book*. Edition (only include this if not the first edition). Place: Publisher.

E.g. Bloggs, J., 2000. *Thermal Comfort*. London: E&F Spon Ltd.

For Dissertation: Author, Year of publication. *Title of dissertation*. Level. Official name of University.

E.g. Bloggs, J., 2000. *Thermal comfort in domestic buildings*. MSc. University of North London.

For journals: Author, Initials., Year. Title of article. *Full Title of Journal*, Volume number (Issue/Part number), Page numbers.

E.g. Bloggs, J., 2000. Thermal Comfort. *Energy and Buildings*, 32(2), pp 100-110.

For conferences: Author(s), Year. Full title of conference paper. In: followed by editor or name of organisation, *Full title of conference*. Location, Date, Place of publication: Publisher.

E.g. Bloggs, J., 2000. Thermal Comfort. *CIBSE National Conference Dublin 2000*, Dublin, Ireland, 20 - 22 September 2000. Balham: CIBSE.

Proceedings of 8th Windsor Conference: *Counting the Cost of Comfort in a changing world* Cumberland Lodge, Windsor, UK, 10f 13 April 2014. London: Network for Comfort and Energy Use in Buildings, <http://nceub.org.uk>

A field study of thermal comfort in transitional spaces in buildings in Cardiff, UK

Guoying Hou¹ and Christopher Tweed²

1 Architectural Science Group, Welsh School of Architecture, Cardiff University, UK, CF10 3NB, houg2@cardiff.ac.uk

2 Architectural Science Group, Welsh School of Architecture, Cardiff University, UK, CF10 3NB, TweedAC@cardiff.ac.uk

Abstract

Transitional spaces are the spaces influenced by the outdoor climate and yet are architecturally bounded by a building envelope. It can be argued that because these spaces are neither fully outside nor inside they create unique environmental conditions that may result in different expectations and perceptions of thermal comfort by those who use them. This paper presents findings from field surveys conducted in two transitional spaces in two different public buildings during the summer in Cardiff, UK. The results suggest that occupants have a higher thermal tolerance in transitional spaces in buildings, and occupants report obviously different levels of satisfaction with thermal conditions in two same service system transitional spaces in summer. This has implications for energy conservation. The findings clarify the relationship between thermal environment and specific character of transitional spaces in buildings.

Keywords: Transitional space, thermal comfort

1. Introduction

Transitional space (TS) in a building is the space not directly occupied in relation to the primary activity of the building, which poses an interesting and fruitful area for energy and comfort research (Pitts and Saleh 2007). TS in buildings can be the most important part in architectural design terms because of the form-giving characteristics of large volumes. TS, because of its impact on a wide range of sense and perceptions of human occupants, have an important role in improving the physical environment in buildings. The complexity of thermal conditions in TS is increased with the diversification of building spaces.

Realistically, such spaces may not require the same high level and close environmental control of more fully occupied spaces, thus a wider variation in conditions and interpretation of thermal comfort maybe permitted. Some studies show that useful energy savings (particularly for heating) are possible by allowing for a modest (and realistic) relaxation of prescribed comfort standards in transitional spaces (Pitts, 2007; Chun et al: 2004).

The fieldwork presented here is a pilot study for a larger study. It focuses on four research questions: 1) Do environmental conditions influence the way people inhabit and use transitional space? 2) What kinds of thermal conditions do people prefer in transitional space? 3) Do people have a higher tolerance towards environmental conditions in transitional space? 3) Can transitional space be designed to use less energy?

One significant advantage of carrying out a pilot study is that it may serve to highlight potential weaknesses or inadequacies in the proposed research methodology. A carefully designed and well-executed pilot study can have substantial benefits in optimizing the research procedure and providing advanced insights on the possible outcomes of the research. The pilot survey of this research was carried out in July-August 2012. It was carried out before a full research project in order to test whether the methodology is valid and to establish whether the strategy is fully capable of capturing the types of data that are required. Furthermore, the pilot study can help to ensure that the research strategy is fully optimized and that the information acquired is reliable (Eng., 1997).

2. Background

2.1 Transitional spaces (TS) in buildings

Over the past decade, increased interest of symbiotic building establishes an increasing need for spaces in which occupants can contact and feel nature. So the space between the totally interior and entirely exterior space came into existence, and includes indoor spaces in close contact with outdoor spaces, as well as sheltered outdoor spaces connected to the building. These spaces always have a vague and flexible function due to the different function and characteristic of buildings and the increase of multiple roles of building. These kinds of space always create new functions, not just the basic function for passing through, such as amusement, dinning, resting etc.

The design of TS in building is considered very important by building designers for many reasons: such as aesthetics, health and comfort etc. Transitional spaces are unavoidable in the design of most non-domestic buildings. The percentage of such areas varies between 10-40 percent of the total volume in different types of buildings (Pitts, 2007).

Transitional spaces defined in this research are the spaces that work as the physical bridges between the interior and exterior environment, providing the space for a flexible functions and a higher activity level than the totally indoor space. They are modifying experience and expectation of person moving through them and these spaces connected with other spaces in building. These spaces always use large areas of glass to contact better with outside space. They include foyers, lobbies, atrium and ancillary spaces.

There are a number of things that differentiate TS in building from full indoor and outdoor spaces:

- The seasonal range of weather conditions is clearly greater in transitional spaces than in the full-occupied space.
- Diversity of space; this is a characteristic which can help people to remain comfortable; it is more flexible than the indoor spaces full occupied.
- Diversity of use; for some people, TS in building are their working environment, for others they are associated with leisure and a means of getting from one indoor space to another. The different requirement and expectation results to the wide variety of possible activities in transitional spaces
- Wider comfort tolerance; many scholars have suggested that the level of discomfort actually measured in transitional conditions is much smaller than indoors. This suggests that people may have a higher tolerance of their environment in transitional spaces
- Buffer between indoor and outdoor space; whereas indoors most people have a good idea to thermally, but the outdoor weather is continuously changing, Transitional spaces provide such an area to release the suddenly change.

2.2 Thermal comfort and Human activity in TS in building

The rapid development of the construction with integrated functions improves the development of TS in buildings, as a modern architecture style with widely used glass, especially in offices and commercial buildings. However, the extensive use of glass without consideration of climate and building orientation has created the fully artificial indoor environment. In these buildings, transitional spaces are generally located at the front of the building and with a wide glass façade. The use of electrically driven ventilation and heating systems, this can cause excessive unnecessary energy consumption for heating and cooling the buildings.

Thermal comfort is defined as ‘the state of human mind, which expresses satisfaction with thermal environment’ (ASHRAE, 2004). In terms of space type and architectural characteristics, the research of thermal comfort is related closely to building’s physical environment. In terms of the end users, the research on thermal comfort considers human activity of physical, physiological and psychological (Lin 2008).

The vast majority of comfort studies have been carried out are indoors (in offices, schools and homes), and recently, thermal comfort in outdoor settings has emerged as a topic. However, the space between outdoor and indoor has received little research attention. There appears to be three main reasons for this: Firstly, people in developed countries where most research has been conducted to date spend a larger proportion of their life indoor rather than outside. Secondly, in work environments, thermal comfort is assumed to be related to productivity directly, so it is considered economically important for

employers to define and provide employees' preferred thermal conditions (Matt DeVeau , 2011). Finally, the outdoor and semi-outdoor thermal environment is considerably more difficult to engineer and control than its indoor counterpart. However, despite these obstacles there are many reasons to further our understanding of thermal comfort in TS in building. Firstly, many recreational activities of considerable commercial value are conducted in TS in building (e.g. cultural event, exhibition, leisure activity). Secondly, an increasing number of weather sensitive business in the service sector, such as restaurant and cafes, are taking advantage of transitional environments. Finally, as J.Spagnolo's states, "many outdoor microclimates previously regarded as beyond control can now be partially controlled and extreme, or at least undesirable, environment conditions can now be filtered or attenuated—hence the recently coined term 'semi-outdoors'".

In this research, the thermal environment will be characterized within different area in TS in building. The relative thermal comfort standard will be obtained from two sources: ISO 7730 Standards (2005) and ASHRAE Standards calculation based on measurements in the TS in building, and the result of the occupant survey in the TS in building. This study is focused on the relative importance of people's thermal comfort and activities level: how the TS in building's different physical characteristics influence on occupants' comfort perception and expectation. The special characteristics of TS in building results in different thermal environmental conditions and human activity levels in these spaces. Equally, different level of human activities can lead to the different requirements of thermal comfort levels in TS in building. Different occupants in TS in building have a different require level of thermal comfort, which increased the complexity to satisfy the different thermal comfort level of occupants and maximize the potential of energy saving in TS in building.

2.3 Energy required heating TS in building

The energy consumption in transitional space has become an important area of research. Transitional spaces do not require the same high level and close control of more fully occupied spaces and thus a wider variation in conditions and interpretation of thermal comfort may be permitted. Environmental conditions in such areas lying between internal and external conditions offer benefits such as reduction of thermal shock for occupants moving into and out of spaces as well as modifying comfort expectations. An additional consideration is that such spaces are often located at the perimeters of buildings: frequently have large areas of glazing and also experience significant air exchange with the outside environment. As such they may require considerably higher levels of building services provision for comfort conditioning and consequently have higher energy consumption.

It is common to find that considerable amounts of energy are required to sustain comfort levels in these environments in line with various prescribed building standards. Indeed some researchers have suggested that the energy

consumption in transitional spaces, per unit area or volume, may be as high as three times that of the remainder of the inside of a building (Miura S *et al*: 1991). But some studies have shown that transitional spaces can help to save energy if they can be developed according to their climatic needs (Chun et al: 2004). The wider aim of this research described here is to explore the relationship between thermal comfort, human activity and energy consumption.

3. Methodology

This study used a questionnaire survey to obtain occupants' perceptions of thermal comfort. Although subjective assessment is difficult to analyze, due to psychological influences, finding the occupants' need to achieve better thermal comfort is an essential first step. Also, this research used physical measurement and monitoring of the surveyed TS in building to confirm the findings from the questionnaire. Details of the questionnaire are described below.

3.1 Thermal comfort questionnaire

3.1.1 Introduction

Thermal comfort investigations in TS in building are more dynamic than those found in the indoor full-occupied space, such as office room, theater etc. When the monitor of thermal environment in TS in building was carried out, there is a greater variety of adaptive opportunities should available and more types of environment condition should be allowed, especially while providing sufficient response without interrupting factors.

To record occupants' perceptions of comfort, there are two methods: observation and recording by camera; and face-to-face surveys (questionnaire and interview). Video recording was rejected because it was considered to be too intrusive and would be likely to interfere with the reporting of comfort perceptions or even skew those perceptions. A face-to-face questionnaire was identified as a way of minimizing disruption and avoiding reliance upon on 'participant self-reporting', which provides the context to the investigation using some background information about the subject. When accompanied by the recording of local environmental conditions, the approach should provide useful data.

3.1.2 Aims and objectives

The questionnaire had two main aims:

- To get the personal information about participants in surveyed transitional spaces; and
- To get the information about thermal history, thermal satisfaction, thermal sensation and thermal expectation condition of participants.

3.1.3 Design of the questionnaire

The working day in Cardiff usually runs from 9.30am to 5.30pm. The questionnaire survey was conducted during this period. According to ASHRAE Standard 55 (2004), the survey should be conducted after at least 20 minutes step change of occupants and this is the needed to enable actual perceived conditions to be reported. The approximate time required to complete the questionnaire was 5-8 minutes.

The questionnaire survey can be divided into subjective and objective variables. The objective variables include gender, age group, and occupation. The subjective variables include occupant satisfaction with their thermal environment and occupant health related categories. The second section asks subjects to rate their thermal satisfaction, sensation and expectation. Thermal satisfaction is ranged as 5 degrees, from very poor to very good. Thermal sensation is rated on ASHRAE 7-point thermal sensation vote (TSV) scale (i.e., -3, much too cool; -2, too cool; -1, slightly cool; 0, neutral; 1, slightly warm; 2, too warm; and 3, much too warm). The thermal expectation was assessed by the occupants' desired thermal comfort preference scales. In the pilot study, the calculation of thermal satisfaction is based on the result of thermal sensation. It was improved as an independent question in formal studies to get a more reliable satisfaction measure of participants. The responses were time stamped.

The questionnaire responses were analyzed using SPSS and Microsoft Excel. The results were analyzed by descriptive analysis including frequency, percentage, and chi-square and cross-tabulation method. Regarding to further investigation of the correlation between various responses, the data were analyzed through cross-tabulation. All the relationships are statistically significant to $P < 0.05$. The missing answers were not analyzed in the assessment and the missing values are not significant to be interpreted in this survey.

The basic method of this research used a questionnaire to collect information about thermal perception of participants in TS in building. This is then connected to the measurement of physical environmental conditions to determine the environment's effect on people's thermal perception in TS in building. A schedule for the questionnaire and interviews was developed on the following basis: the sample size should be large enough to capture the diurnal temperature swing and a variety of subject activity; a five-minute questionnaire applied every twenty minutes was used; a short interview was used with staff working in each space rather a questionnaire to avoid unnecessary interference with their work.

3.2 Physical measurement

The field experiments aimed to assess the indoor and outdoor thermal condition of target buildings with transitional space in Cardiff, UK. Air Temperature, Globe Temperature, Ventilation and Relative Humidity were measured inside the case studies while Air Temperature and Relative Humidity of outside were measured simultaneously during field experiments.

3.2.1 Aims and objectives

The aim and objectives of the field experiments are:

- To quantify the thermal environment in TS in building and combine the results with questionnaire to investigate participant's thermal perception in TS in building
- To establish the range of internal and external thermal conditions found in transitional space

3.2.2 Field experiment procedure

After gaining permission in two selected buildings in Cardiff, the field experiments were conducted. These buildings were chosen from a mixture of types including highly glazed, modern design in heavy weight and lightweight structure up to 10 years old. Although the sample type is not a representative of the transitional spaces' type as a whole in Cardiff, these two buildings have been selected to compare their environmental conditions and to establish some initial information on TS in building. The field experiments were carried out during the summer in Cardiff (August). The measurements were recorded in occupied transitional spaces in both buildings. The equipment was placed close to the occupants and in the spaces with multiple occupants. The equipment was placed in locations deemed representative of the space as a whole with almost the same distance from the occupants. The equipment was positioned away from windows, sunlight, cooling/heating units and computers. In all the studied transitional spaces the air temperature, humidity, ventilation and globe temperature have been measured as environmental factors and the measurement has been continued for 7-8 days. The interval recording was set to 2 minutes for air temperature and humidity and 5 minutes for globe temperature. These parameters were measured in different parts of transitional spaces in each building.

3.2.3 Equipment and arrangement

Depending on the size of the space, 5-7 sensors were used to measure the thermal environment. Air temperature and relative humidity were measured using the same sensor, a solid-state device that changes its electrical characteristics in response to extremely small changes in air temperature and humidity. Globe temperature determines heat flow between the bodies and surrounding surfaces, it is measured as the internal temperature of a hollow sphere exposed to environment. The recorded temperature were transferred onto a computer connect to the data receiver. Air velocity was measured using a hotwire thermo-anemometer.

The dividing of physical measurement areas in TS in building was based on the different functions and area of space. Different numbers of sensors for air temperature and relative humidity were stationed in each area, and mounted 1.5-2m from floor. The air speed meter was handheld and used when the researcher carried out the questionnaire survey.

The fundamental characteristic of all measuring systems is that they will be influenced slightly by many factors other than the parameters of interest and this will

contribute to the quality of measurements. It is no exception in this research. The interference factors will be excluded as much as possible by the methods of questionnaire and observation.

3.3 Cases

Generally, TS in building space is public space of the whole building; people carried out more flexible and diverse activities than in rooms with specific functions in the same building. There are some similar characteristics of these two cases TS in building:

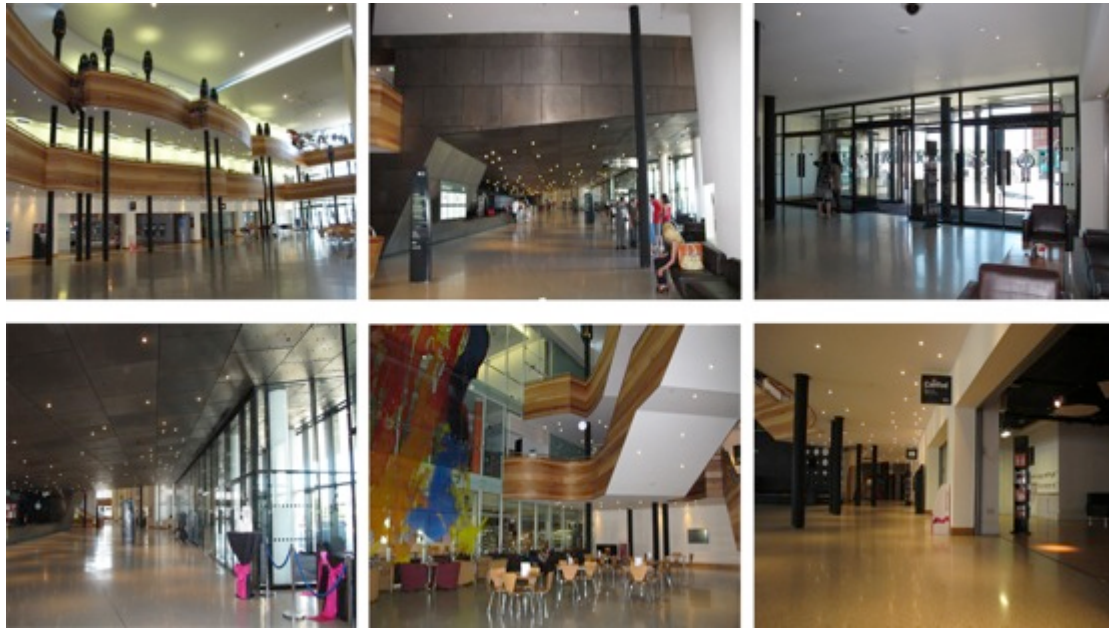

Figure 3-1: The foyer of the AGU

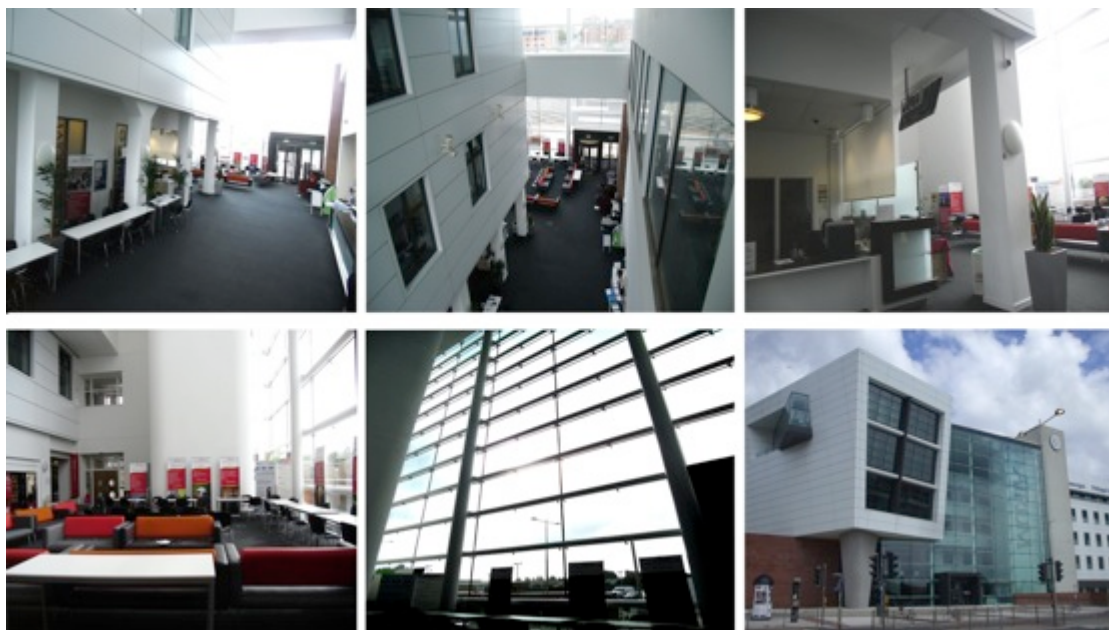

Figure 3-2. The foyer of the WMC.

- Generally, the types of TS includes: corridors, reception, collecting and distributing area and resting area.
- There is greater variety in the activities in these spaces than other spaces in this building.
- Most visitor stay in TS in building for a relatively short time, this is different to fully occupied indoor space.

According to the regulation above, two suitable cases were chosen in this research: the foyer of the ATRium Building of Glamorgan University (AGU) (Figure 3-1) and the foyer of the Welsh Millennium Centre (WMC) (Figure 3-2). The main physical characters of these three cases are shown in Table 3-1.

Table. 3-1 Basic information about physical character of three cases

Building		AGU	WMC
Date of building		2007	2004
Building area		3450 m ²	19020 m ²
Transitional space area		810.25m ²	2198.41m ²
Building Service system	Winter	Electrical Under floor heater	Mechanical ventilation with heating
	Summer	Mechanical ventilation	Mechanical ventilation
Building orientation		South	East
Business type		Academic	Cultural-business
Dates of studies		16,17,20,21,22,23 24 August 2012	29,30,31 August, 02,03,04,05 September 2012

4. Analysis and discussion of research results

The pilot study was carried out at AGU and WMC at the end of August and beginning of September 2012. The questionnaire responses were analyzed using the SPSS statistical analysis program. The studied transitional spaces in buildings with the response rate are 97% (161 out of 165). The survey responses were 73 and 88 respondents separately in AGU and WMC respectively. The results and discussion of this survey are divided into the five sections below.

4.1 Basic data

The respondent's background and response has been summarized from 17 survey questions. The basic data about personal information for the occupants responding to the survey are summarized in Table 4-1. Among the participants, 33.8% of them are

Table 4-1 Personal basic information got from questionnaire

		AGU	WMC
Elements	Category	Percentage	Percentage
Gender	Female	37.3%	44.9%
	Male	61.3%	55.1%
Age	16-24	32.0%	18.0%
	25-34	37.3%	13.5%
	35-44	13.3%	16.9%
	45-54	10.7%	18.0%
	55-64	4.0%	13.5%
	65-74	2.7%	19.1%
	74over	0%	1.1%
Occupation	Professional	33.8%	57.1%
	Clerical/secretarial	15.5%	32.5%
	Student	50.7%	10.4%
Live Location	Cardiff	82.7%	25.8%
	Outside Cardiff	17.3%	74.2%
Period of occupant	Less than 1year	9.8%	4.9%
	1-2years	21.3%	6.1%
	3-5years	29.5%	12.2%
	More than 5 years	39.3%	76.8%
Frequency of visit	Daily	29.7%	9.0%
	Several times per week	18.9%	31.5%
	Several times per month	27.0%	11.2%
	Rarely	17.6%	25.8%
	None	6.8%	22.5%
Duration of Visit	Less than 20 minutes	10.0%	7.9%
	20 minutes-2 hours	14.3%	57.3%
	2-4 hours	24.3%	9.0%
	4-6 hours	12.9%	10.1%
	6-8 hours	32.9%	10.1%
	More than 8 hours	5.7%	5.6%

professional, 15.5% are clerical and 50.7% are student in AGU; and in WMC, 57.1% are professional and 32.5 % are clerical, only 10.4% of participants are student. The participants' age group shows that the majority of the participants are at the age group of 16-44 years with 61.3% male and 37.3% female participants in AGU, and majority of the participants are at the age group of 16-74 years and ranged averagely with 55.1% male and 44.9% female participants in WMC.

Further questions revealed that 82.7% of participants in AGU live in Cardiff, but in WMC, 74.2% of participants live outside Cardiff, and most of them stay there more than three years. It means that the participants in AGU are more familiar and used to Cardiff's weather than the participants in WMC, so participants in AGU have a more exact judgment about the discomfort of the local weather.

In terms of the reason of visiting the building, 77.7% participants come to the building for working and studying in AGU. However, most participants in WMC come to the building just for visiting and entertainment, 43.2% and 19.3% respectively. It is obvious that the participants in these two buildings visit them with different objectives. According to their experience, participants in AGU tend to be more exact or fastidious about the temperature of their environment, because people's requirements from an environment for studying and working is higher than for visiting and for entertainment.

It shows than 75.6% of the respondents in AGU and 51.7% in WMC are visit the building more than rarely. Among it, 29.7% of the participants visit AGU daily while 18.9% are visit it several times a week and 27.0% are several month a week. In terms of WMC, there is only 9% of the participants visit it daily while 37% of them visit it several times a week, and there are 11.2% of them visit it several times a month. In AGU, most of the participants stay in the building more than 2 hours, and in WMC most of them stay in the building more than 20 minutes. It is indicated that most participants were familiar the TS in building they occupied and able to judge any thermal environment discomfort in the TS in building.

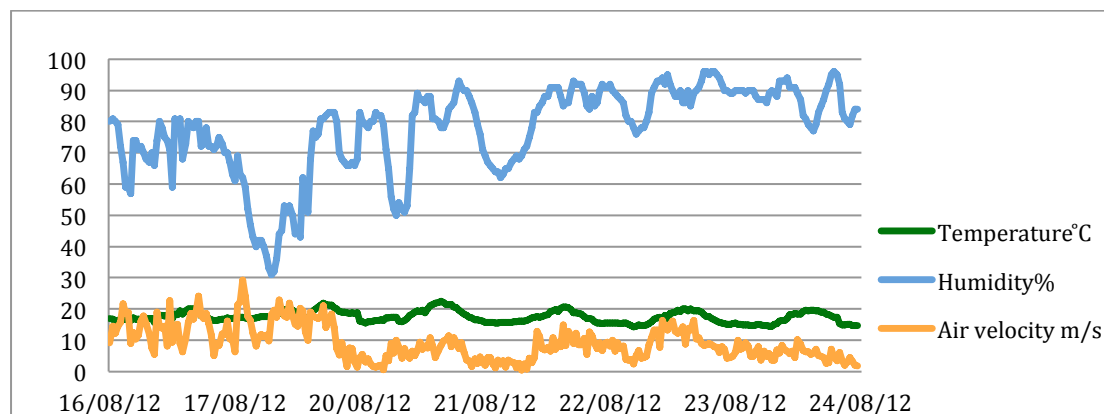

Figure 4-1 Exterior Temperature, Humidity And Air Velocity of AGU

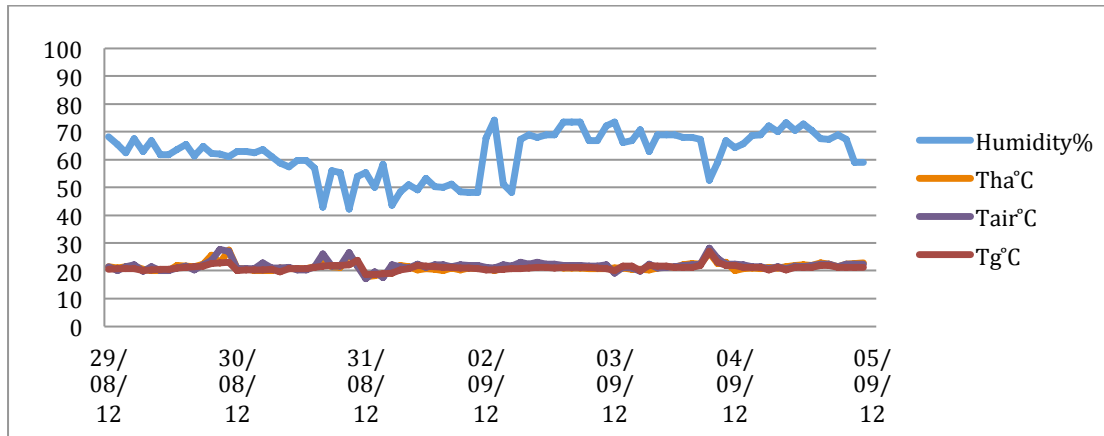

Figure 4-2 Interior Temperature, Humidity of AGU

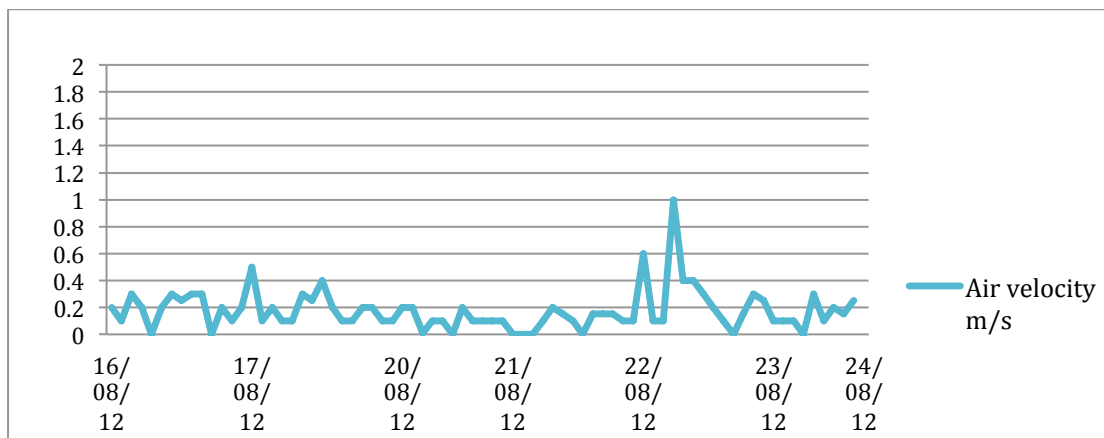

Figure 4-3 Interior Air Velocity of AGU

4.2 Thermal environment

Figure 4-1 to 4-6 indicate that the recorded environment condition at outside building and inside building during the survey time in two cases. The measured outside environment parameters include air temperature, humidity and air velocity. The inside measured environment parameters include humidity and air temperature measured by sensors set close to participants (T_{air}), air temperature around participants measured by hand held equipment (T_{ha}), globe temperature (T_g) and air velocity. These figures indicate that the average temperature in WMC transitional space is 2.5°C lower than in AGU during the survey time they are 23.9°C and 21.4°C separately, and the air velocity in it during a day is more dynamic than in AGU. Also the recorded air temperature and globe temperature compared in Figure 4-2 and Figure 4-5 indicates that almost the same value with little time discrepancy not greater than 4.5 °C in each TS. It also indicates that the temperature in AGU is more stable than in WMC. The analysis from these figures overall, compared together and shows that the temperature in transitional spaces in buildings was affected by both indoor and outdoor temperature.

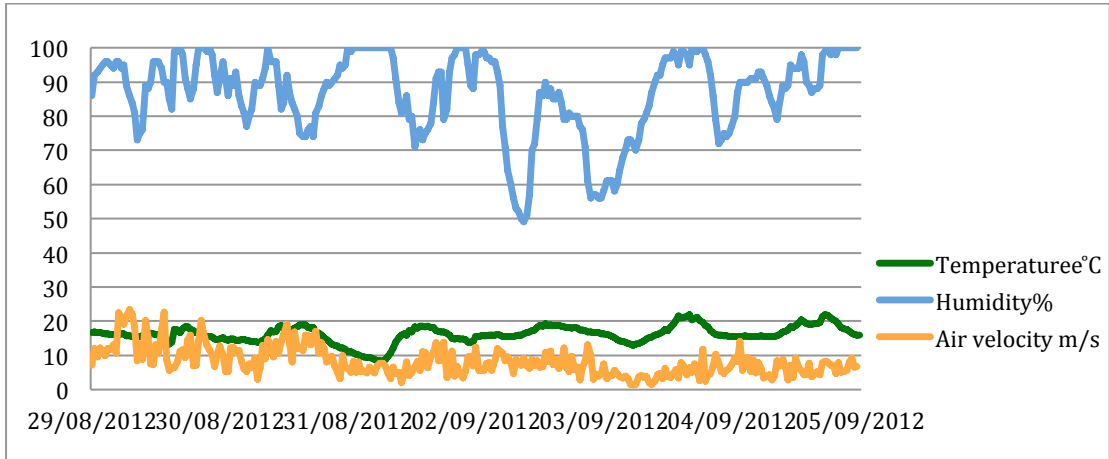

Figure 4-4 Exterior Temperature, Humidity And Air Velocity of WMC

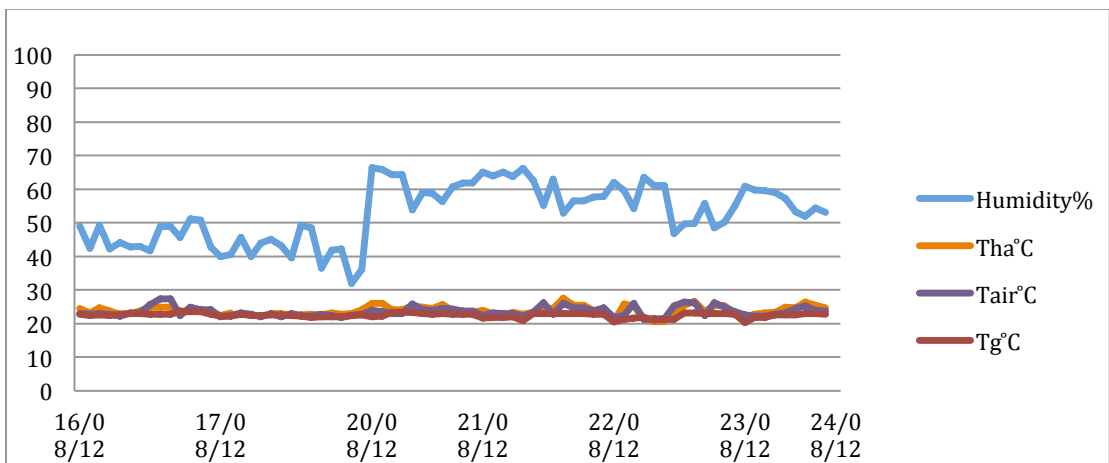

Figure 4-5 Interior Temperature, Humidity of WMC

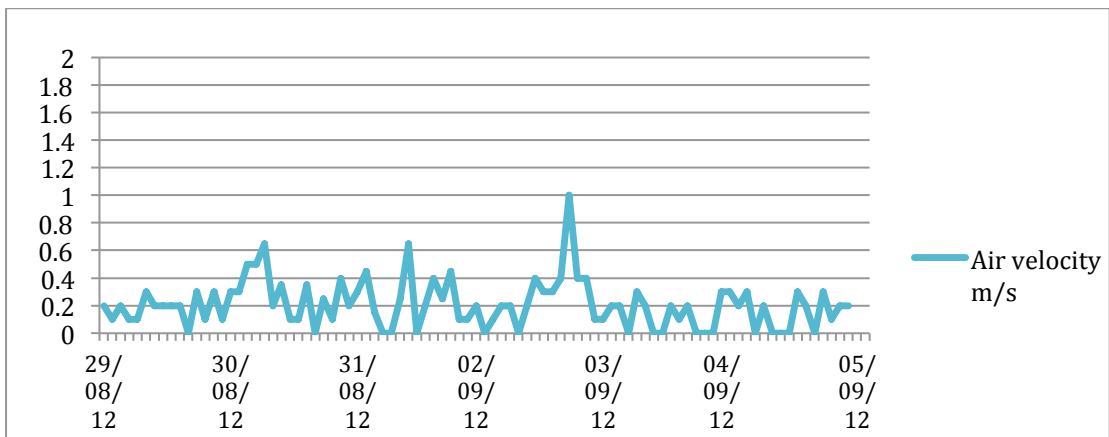

Figure 4-6 Interior Air Velocity of WMC

4.3 Thermal sensation and satisfaction

Figure 4-7 shows the distribution of thermal comfort satisfaction scores for all occupants (the satisfied rate range is from slightly warm to slight cool, other ranges are dissatisfied rate). Overall, in AGU, more occupants are satisfied (86.3%) than dissatisfied (13.7%). Note that the relatively high percentage of response is in the neutral category (41.1%) and in slightly warm (31.5%). However in WMC, there is a totally different view, the satisfied rate is quite high as 98.9%, and the neutral

category is as high as 73.9%. Also figure 4-7 compares the results of the questionnaire over all the transitional spaces studied with the ASHRAE Standard 55 (2010) thermal comfort conditions. With regard to this result it can be said that overall the thermal environment in respondent's occupied transitional space was generally reported neutral and slightly warm condition in the studied spaces in later summer.

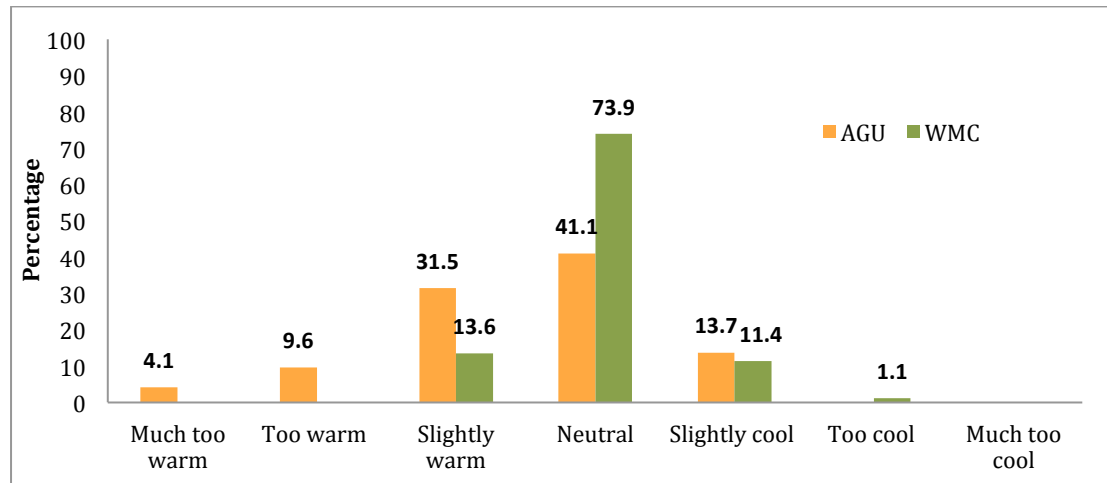

Figure 4-7 Respondent's satisfaction with thermal comfort in the transitional space of AGU and WMC

ASHRAE Standard 55 (2010) defines acceptable conditions in which at least 80% of people are satisfied with their thermal environment. In this study, the calculation of thermal satisfaction is based on the rate of thermal sensation. The survey result shown in figures 4-7 clearly indicates higher rates of thermal satisfaction in each transitional space in building. It reveals in AGU more than 13.7% of the occupants were positively dissatisfied with the temperature in transitional spaces which is more close to the acceptable dissatisfied range (10%) specified by ASHRAE Standard 55 (2010). However, in WMC the dissatisfied rate is just 1.1%, far below the acceptable dissatisfied range. Figure 4-7 indicates that both two buildings are in compliance with the ASHRAE Standard 55 (2010). At the same time, it appears that the occupant's perceived satisfaction with the temperature in these two transitional spaces in building are in compliance with the acceptable thermal satisfaction rate within ASHRAE Standard 55 (2010) either.

The thermal sensation of different temperature range in each transitional space is compared as figure 4-8: 1) in WMC, the temperature range is wider than in AGU; 2) at the temperature range 20.01-22.00°C, only few participants in AGU are feel neutral but most participants in WMC are have the same feeling and a highest satisfactory rate (70.5%) than other temperature range; 3) at the temperature range 22.01-24.00°C, participants in AGU have a higher response at neutral category than participants in WMC and a highest satisfactory rate as 46.6% than other temperature range; 4) at the temperature range 24.01-26.00°C, there is a highest rate of slightly warm in AGU and a higher satisfactory rate (28.7%), which is totally different with WMC because almost no response at this temperature range.

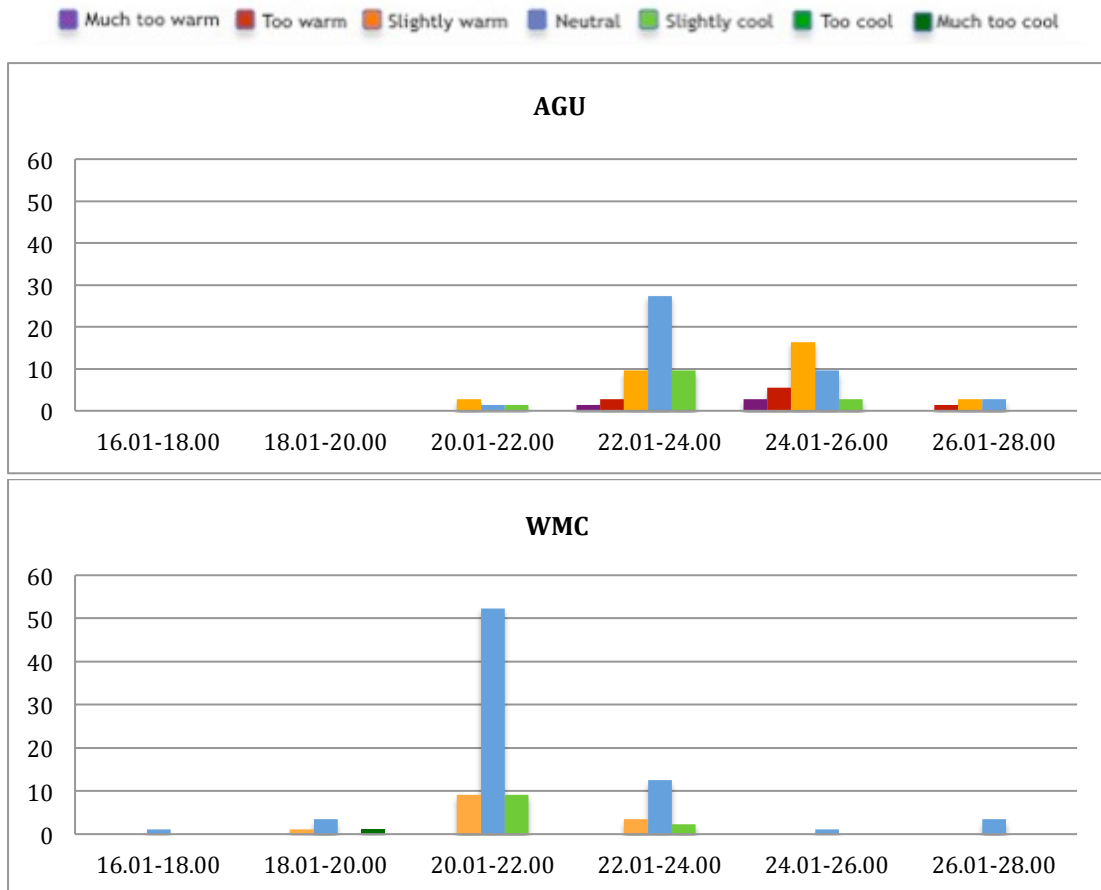

Figure 4-8 A cross-tabulated between the respondent's satisfaction with the temperature and the buildings

This was generally supported by the physical measurement that the temperature in AGU transitional space is high than WMC. It can be responsibly refer to that occupant's thermal history have an important influence on their thermal sensation and satisfaction. In transitional spaces, when participants experience a warmer thermal environment, they have a higher tolerance about higher temperature and vice versa.

4.4 Thermal expectation

The analysis in Figure 4-9 shows the distribution of thermal expectation votes across all respondents. It indicates that most of the respondents (80.7%) in WMC were like to thermal condition around them keep at neutral while about half occupants (50.7%) in AGU have the same feeling. In the transitional space of AGU, 24.7% participants like their environment slightly cooler when just only 4.5% participants in WMC have the same feeling. In terms of the thermal expectation category of slightly warmer, these two building have a similar equal scores, 11% in AGU and 12.5% in WMC. And there are 8.2% participants like cooler and 4.1% like much cooler in the transitional space of AGU, but in WMC, nobody choose these expectation categories.

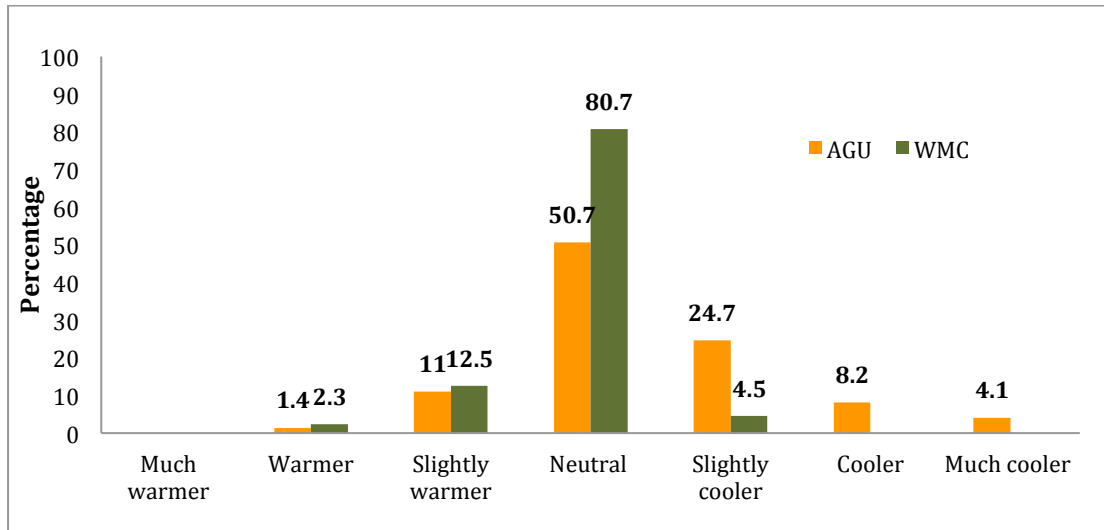

Figure 4-9 Respondents' expectation with thermal comfort in the transitional space of AGU and WMC

In the transitional space of AGU, during the number of participants feel their environment is neutral (41.1%), there were 34.2% of participants choose not change their thermal environment, but there is only 4% of them like to slightly warm and 3% of them like to slightly cool. And among the participants feel their environment is slightly warm, there are 2.7% of them like to slightly warmer, 4.1% of them like to cooler, 11% of them like their thermal environment became neutral and 13.7% of them like to slightly cool. This is a totally different situation in the transitional space of WMC. During the participants choose their thermal environment as neutral score, 9% of them like too slightly warmer, 68.2% participants like to keep neutral and only 3.4% of them like their environment slightly cooler. (Table 4-2 and 4-3)

Table 4-2 A cross-tabulated between thermal sensation and thermal expectation in TS in AGU

		Thermal expectation						
		Much warmer	Warmer	Slightly warmer	Neutral	Slightly cooler	Cooler	Much cooler
Thermal sensation	Much too warm	0	0	0	0	0	0	0
	Too warm	0	0	0	0	6.8%	2.7%	0
	Slightly warm	0	0	2.7%	11%	13.7%	4.1%	0
	Neutral	0	0	4.1%	34.2%	2.7%	0	0
	Slightly cool	0	1.3%	4.1%	5.5%	1.3%	1.3%	0
	Too cool	0	0	0	0	0	0	0
	Much too cool	0	0	0	0	0	0	0

Table 4-3 A cross-tabulated between thermal sensation and thermal expectation in TS in WMC

		Thermal expectation						
		Much warmer	Warmer	Slightly warmer	Neutral	Slightly cooler	Cooler	Much cooler
Thermal sensation	Much too warm	0	0	0	0	0	0	0
	Too warm	0	0	0	0	0	0	0
	Slightly warm	0	0	1.1%	9%	3.4%	0	0
	Neutral	0	1.1%	4.5%	68.2%	0	0	0
	Slightly cool	0	0	6.8%	3.4%	1.1%	0	0
	Too cool	0	1.1%	0	0	0	0	0
	Much too cool	0	0	0	0	0	0	0

These two table indicate that: 1) in TS in buildings, occupants' thermal expectation is obviously effected by their thermal history in the same environment; 2) comparing to WMC, there are about 10% occupants' in AGU choose cooler as their favor thermal comfort station, the most possible explain is AGU have a higher thermal environment temperature than WMC; 3) in TS in buildings, most occupants think neutral is the most satisfied thermal condition, especially in WMC, this percentage is as high as 81.6%; 4) it is proved that the thermal sensation range from slightly warm to slightly cool is the occupants satisfied range in TS in building.

4.5 PMV and PPD model

The PMV-model by Fanger is used to predict whole-body thermal comfort. It is also recommended to use the PMV index only for values of PMV between -2 and +2 (ISO 7730 2010). The PPD (The predicted percentage of dissatisfied) index predicts the mean value of thermally dissatisfied people, and the PPD index values of PPD<15% is the normal satisfaction range. The PMV-PPD model was used in this study to predict participants' satisfaction of their thermal environment around them.

To investigate if occupants in TS in buildings have special favor area, TS in each building is split as four areas as area A, B, C and D as Figure 4-10. The results of satisfaction rate in different area of transitional space is as Figure 4-11, it shows that there is an obvious favorite area A in AGU with the satisfaction rate as 54.9%. In WMC the satisfaction rate in each area is average, but area C and D is still have an obvious higher satisfaction rate than area A and B. The results of satisfaction rate in

each area get form questionnaire used to comparing with the results get from PMV-PPD model to test the feasibility of this model work in TS in buildings.

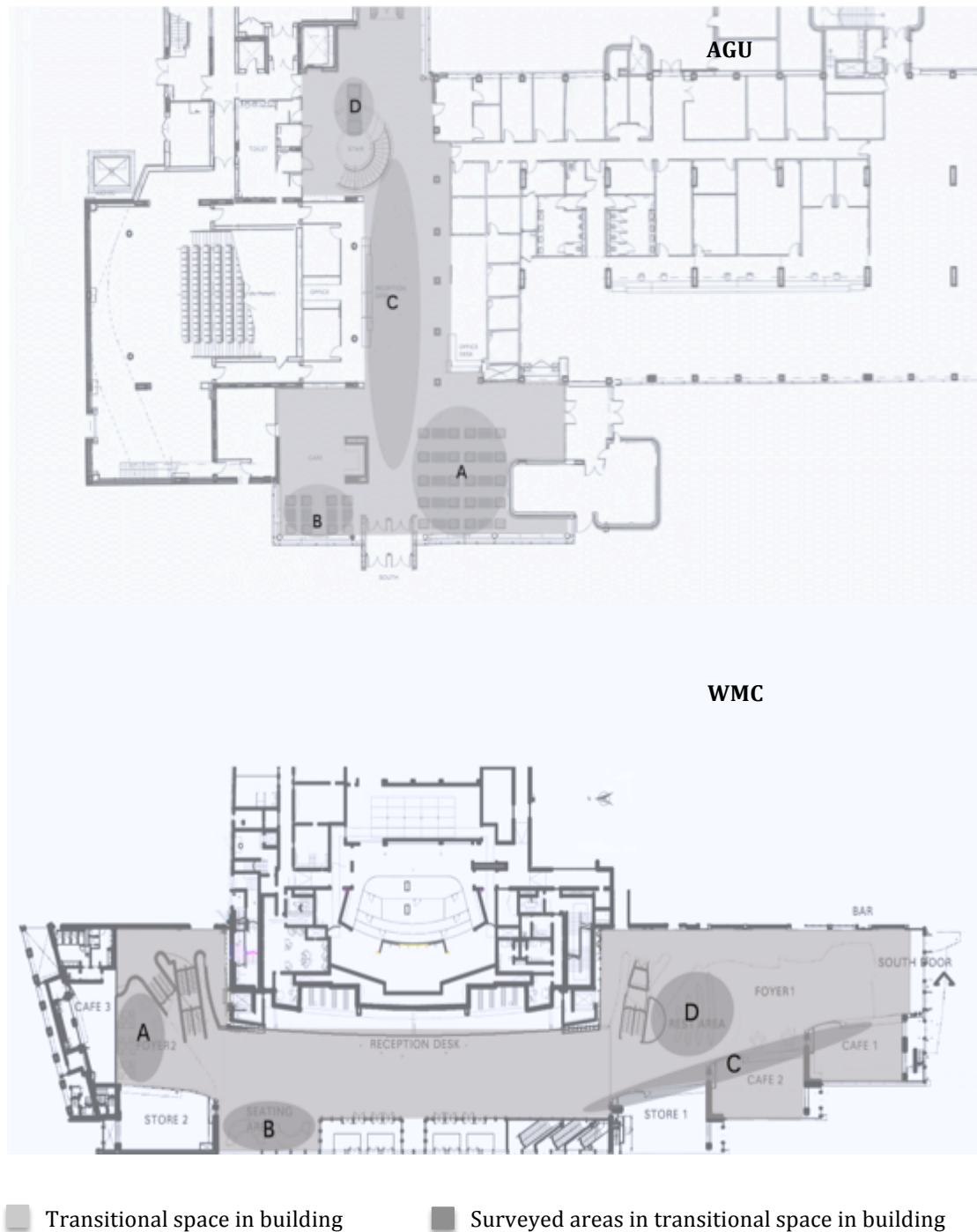

Figure 4-10 Surveied areas in transitional space of AGU and WMC

Figure 4-11 indicates that this model is work in AGU very well because the result is consistent with the result of questionnaire survey. However, in WMC, the result of this model is totally converse with the questionnaire results. To investigate the reason of this phenomenon, a comparison of physical and participants' character between these two cased is conducted as Table 4-2.



Figure 4-11 The result of PMV-PPD model using in cases

Table 4-2: The main different characters of two cases

Comparison with the different characteristic of AGU and WMC			
		AGU	WMC
Physical Characteristics	Area	810.25m ²	2198.41m ²
	Air temperature (average)	23.90 °C	21.41°C
	Thermal environment	Relatively stable (more closing to inside environment)	Relatively dynamic (more closing to outside environment)
Participants' Characteristics	Age	16-34 years old: 69.3%	Average
	Live in Cardiff	82.7%	25.8%
	Visit frequently	75.6%	51.7%
	Stay time (2-8hours)	70.1%	29.2%

After combining these results with SPSS correlation and regression analysis, it is inferred that the main reason of PMV-PPD model does not work in WMC is its dynamic thermal environment. The WMC is a very popular space in Cardiff Bay, people visit it for refreshment, exhibition, opera, performance, using toilet, using cash machine and to access the tourist center etc.. So, the main door of transitional space is opened and closed very frequently, and because this is not a revolving door but a slow response automatic door, the inside thermal environment of transitional space in WMC is not as stable as in the AGU. It is almost as dynamic as the outside thermal environment, as a result the PMV-PPD model cannot work in this space. To investigate if participants are happy with the dynamic thermal environment in transitional spaces, a new question about that added to the subsequent formal study questionnaire.

5. Conclusions

This study is giving a more detailed definition of transitional spaces in buildings. It shows that transitional spaces in buildings are complex and diverse in design, and always serve multiple functions for participants. Transitional space can offer a wide range of adaptive opportunities (choice of sitting area, wider range of possible physical activities, greater tolerance of dress code etc.). When people stay in the transitional spaces in buildings, they tend to experience a dynamic interaction with changes in temperatures.

Due to the dynamic thermal condition in transitional spaces in buildings, occupants experience at multisensory levels and tolerate greater temperature range than in fully occupied spaces, it can help to reduce energy consumption in building. But the PMV-PPD model is not suitable for all of the transitional spaces in buildings, because in some spaces the thermal environment is as dynamic as outside environment condition.

This fieldwork is the pilot study for a larger research investigation. It has highlighted some improvements to benefit to the formal study as follows: 1) improving the design of questionnaire (content, format and layout); 2) changes to the method of recruiting participant to get more reliable and trustable responses; 3) change a more flexible timetable to apply questionnaires to cover a widely temperature range; 4) changes to the location of monitoring equipment to get the results with least interference; 5) increasing the number of monitoring devices, and making the equipment more manageable to improve accuracy; 6) improving the method of combining questionnaires with physical measurements to get a more reliable results.

References

- Aydinalp M, Fung A,. 2000. Ugursal VI.2002. Household end-use energy consumption in 1997. Halifax, Canada. *CREEDAC-2000-08-02 report*.
- ASHRAE 2004. *ANSI/ASHRAE Standard 55-2004*. Atlanta: American Society of Heating, Refrigerating and Air-Conditioning Engineers, Inc.
- B. Givoni. 1989. *Urban Desian in Different Climates, World Meteorological Organization* .
- Brager GS, de Dear RJ. 1998. Thermal adaptation in the built environment: a literature review. *Energy and Buildings*, 27, pp83–96.
- Brager GS, Paliaga G, De Dear R, Olesen B, Wen J, Nicol F, et al. 2004. Operable windows, personal control, and occupant comfort. *ASHRAE Transactions*, 110, pp17–35.
- Chun C, Tamura A., 1998. Thermal environment and human responses in underground shopping malls vs. department Stores in Japan. *Building and Environment*, 33.
- Chungyoon Chun, 2004. Thermal comfort in transitional spaces-basic concepts: literature review and trial measurement, *Building and environment*, 39, pp1187-1192.
- E. Lieberman, 2008. *Personal communication*, January 18.
- Eng. R. 1997. *Thermal comfort, environmental satisfaction and perceived control in UK office buildings*. University of Liverpool.
- Feriadi H, Wong NH. 2004. Thermal comfort for naturally ventilated houses in Indonesia. *Energy and Buildings*, 36, pp614–26.
- Fanger PO. 1972. *Thermal comfort*. New York: McGraw Hill.
- Fouad Ahmed-Ouameur, B.Arch. André Potvin, M.Arch. 2007. Microclimate and thermal comfort in outdoor pedestrian space, Conference Proceedings of the American Solar Energy Society (ASES), *Solor*, 7-12 July, Cleaveland, Ohio.
- Griffith B, Crawley D. 2006. Methodology for analyzing the technical potential for energy performance in the U.S. commercial buildings sector with detailed energy modeling. IBPSA-USA, *SimBuild conference*, Cambridge, Massachusetts.
- Gagge AP, Fobelets AP, Berglund LG. 1986. A standard predictive index of human response to the thermal environment. *ASHRAE Transactions*, 92, 709–731.
- Hwang RL, Lin TP. 2007. Thermal comfort requirements for occupants of semi-outdoor and outdoor environments in hot-humid regions. *Architectural Science Review*, pp50:60–67.
- I.A. Meir, David Pearlmutter, Yair Etzion, 1995. *Building and Environment*, Vol. 30. No. 4, pp563-572.
- ISO 7730, *Moderate thermal environments—determination of the PMV and PPD indices and specification of the conditions for thermal comfort*. International Organization for Standardization.
- John Zacharias, 2004. *Environment and Behavior* .
- K.Jitkhajornwanich, A.C. Pitts, 2002. Interpretation of thermal responses of four subject groups in transitional spaces of buildings in Bangkok, *Building and*

Environment, 37, pp1193–1204.

Lasagna, Cecilia Marta, 2011. Developing a modeling factor index for transition spaces: a case study approach, *Architectural Science Review*.

Linda Groat, David Wang, 2002. *Architectural Research Methods*.

Lin, Z. and Deng, S. 2008. A study on the thermal comfort in sleeping environments in subtropics—developing a thermal comfort model for sleeping environments. *Building and Environment*, 43, pp70-80.

Lukas G. Swan *, V. Ismet Ugursal, 2009. *Modeling of end-use energy consumption in the residential sector: A review of modeling techniques*, *Renewable and Sustainable Energy Reviews* 13.

Marialena Nikolopoulou, Nick Baker and Koen Steemers. 2001. Thermal comfort in outdoor urban spaces: understanding the human parameter. *Solar energy* Vol.70, No.3,pp.227-2

Matt DeVeau, 2011, *Strategies to address the climatic barriers to walk able, transit-oriented communities in Florida*, Georgia Institute of Technology School of City and Regional Planning.

Nakano J, Tanabe S. 2004. Thermal comfort and adaptation in semi-outdoor environments. *ASHRAE Transactions*, 110, pp543–553.

Nikolopoulou M, Baker N, Steemers K. 2001. Thermal comfort in outdoor urban spaces: understanding the human parameter. *Solar Energy*, 70, pp227–235.

Noe'' 1 Djiongyang, Rene Tchinda, Donatien, Njomo. 2010. Thermal comfort: A review paper. *Renewable and Sustainable Energy Reviews*, 14, pp2626–2640

PaciuckM.1990. *The role of personal control of the environment in thermal comfort and satisfaction at the workplace*. In: Selby R, Anthony K, Choi J, Orland B, Coming of age. Oklahoma: Environment Design Research Association.

Pitts, A. and Saleh, J. B. 2007. Potential for energy saving in building transition spaces. *Energy and Buildings*, 39, pp815-822.

Spagnolo. J., de Dear RJ. 2003. A field study of thermal comfort in outdoor and semi-outdoor environments in subtropical Sydney Australia. *Building and Environment*, 38, pp721–738.

Wong. NH., Feriadi H, Lim PY, Tham KW, Sekhar C, Cheong KW. 2002. Thermal comfort evaluation of naturally ventilated public housing in Singapore. *Building and Environment*, 37, pp1267–1277.

Victor Olgyay, 1963. *Design with climate: bioclimatic approach to architectural regionalism*, Princeton, N.J: Princeton University Press.

WINDSOR CONFERENCE 2014

COUNTING THE COST OF COMFORT

WORKSHOP 5

Daylight and Comfort

Invited Chairs: Luisa Brotas and Jan Wienold

WINDSOR CONFERENCE 2014

COUNTING THE COST OF COMFORT

THE WORKSHOP PROGRAMME

WORKSHOP 5: Daylight and Comfort

Invited Chairs: Luisa Brotas and Jan Wienold

12th April 2014: 16.30 – 18.30 – Flitcroft Room (2 Hours)

As issues like the cost of energy and the comfort impacts of more extreme weather events begin to matter more to building users and management because of their comfort, productivity and budget implications, the vital relationship between optimising the daylight performance of buildings while minimising the comfort penalties of doing so become increasing key to the success of building designs. New metrics on daylight, glare, visual comfort, adaptation and dynamics of light as well as its relation with artificial light and controls are pivotal to this agenda. In this workshop three papers on the subject will be presented and discussed in relation to the many different aspects and benefits of comfort in well-lit buildings that do not tend to overheat, central issues to this 2014 Windsor Conference.

Illuminating Adaptive Comfort: Dynamic Lighting for the Active Occupant

Zoltán Nagy^{1,*}, Mike Hazas², Mario Frei¹, Dino Rossi¹ and Arno Schlueter¹

¹ Architecture and Sustainable Building Technologies, ITA, ETH Zurich, Switzerland

² Socio-Digital Sustainability Research Group, Lancaster University, UK

* corresponding author: nagyz@ethz.ch

Abstract

This paper makes the assertion that established concepts from thermal comfort research might be used to develop an adaptive comfort model for lighting. By gathering data from a live office environment, we demonstrate the necessity of dynamically-adapted lighting levels in order to achieve both comfort and energy savings. We detail the background and the experimental setup that is used to extract the light levels at which the occupant switches his lights on. We show how individual occupancy information can be estimated from passive infrared (PIR) motion sensors, making fixed, global set points unnecessary. Finally, we demonstrate the successful implementation of the control system.

1. Introduction

There exists a great body of research related to occupant *thermal* comfort; this research has debated various definitions for comfort, and understanding how they vary across people, buildings, and throughout history. Specifically, it has been shown that thermal comfort is highly localized in space and time, and that humans are capable of both acclimatising and adapting in response to changing environmental conditions (Nicol et al, 2012), (Clear et al, 2013). In this research, we hypothesize that similar conclusions can be drawn for lighting comfort. Some implications are that lighting levels might be variably adjusted or drifted automatically over the day and with the seasons; and that local supplementary lighting might be carefully applied to reduce the prevalence of lighting entire rooms or buildings throughout their operating hours.

In numerous field studies, it has been observed that illuminance thresholds vary greatly from person to person and depending on the performed task. This results in general guidelines for workplace light levels, e.g., 500-1000lux for offices. However, such static yet vague guidelines cannot be used to create a lighting strategy, which supports adaptive comfort. Not only is the range of the switch-on threshold too large (Gunay et al, 2013),(Reinhart and Karsten, 2003), but it glosses over the fact that appropriate lighting levels change over time, even for the same person in the same place.

In this work we identify analogies between thermal and lighting comfort, and interrogate if and how knowledge gained from thermal comfort research can be translated to lighting comfort. In working through these issues, we present empirical light threshold and occupancy data gathered in several offices in the research group of the authors at high temporal and spatial resolution. Based on this data, and as an initial exploration into adaptive comfort through lighting, we formulate a distributed

lighting control system that is capable to adjust the switch-on and switch-off thresholds individually for each office.

We postulate that the increased widespread use of inexpensive LED lighting in buildings will create new opportunities for automatically controlled dimmable lighting (Aldrich et al, 2010), which in turn requires a deeper understanding of lighting comfort and its variability. Our research contributes to this through a theoretical analysis and a field study, informed and inspired by important lessons from adaptive thermal comfort.

2. Applying the Adaptive Model to Lighting

“If a change occurs such as to produce discomfort, people react in ways which tend to restore their comfort.”

Nicol, Humphreys and Roaf (2012), p. 29

We start with the familiar acknowledgement that comfort is dynamic, depending on the person, their activity, their previous experience, and the indoor and outdoor environment. The adaptive model for *thermal* comfort aims to create indoor environments and situations where the occupant is able to make themselves comfortable through a variety of adjustments: windows and ventilation, clothing, hot and cold drinks, moving between rooms, and minimal-energy mechanical heating and cooling. We posit that constructive analogies exist for rethinking indoor lighting, within an adaptive comfort model.

- **Person-centric and temporally dynamic**, rather than static across space and time: instead of providing constant levels of light across offices, hallways and kitchens (a global, fixed set point), we should rather embrace variation by supplying a minimal base or background level of lighting during occupied times, with capacity for further adjustments to be made quickly and easily. Such adjustments would be through adaptive measures applied by the occupant, sensitively supported and enhanced by automated systems. In other words, the fundamental approach to lighting should become person-centric (*comfort-as-goal*) rather than environment-centric (*comfort-as-product*).
- **Highly localized**: To support such person-centric comfort, those working on heating have highlighted that small, radiant heat sources (such as an electric fire or personal foot warmer) can be applied just for the time warmth is required. For lighting, the analogy might be a narrow-beam desk lamp, which can be switched on temporarily for close work, rather than raising the level of artificial light for the entire room. Previous adaptive comfort research tells us that occupants with more perceived control tend to be more satisfied with the adjustments they can make depending on their activity, task or mood. Clearly, lighting levels should be appropriate to the activities occupants are engaged in; but even for comparable activities, what is seen as appropriate or even

“normal” lighting varies between people, and can vary even for the same person at different times.

- **Slow changes** made by an automatic system allow the occupant time to gradually adjust, and are less likely to provoke discomfort. Fast changes (such as the lights suddenly switching off) may be noticeable, distracting and create an unsettled feeling. Thermal comfort research has indicated limits on changes by no more than a degree Celsius or so in the short term (a day), with no more than a few degrees in the running mean over longer terms (a week). We have very little information about how much change in the long and short term might be acceptable for lighting. But supporting such slow changes (over a day or season) might require the availability of dimmable lighting; or otherwise large numbers of smaller lights, carefully coordinated.
- **Indoor lighting should be varied as natural light levels change:** Finally, a key observation from adaptive thermal comfort is that indoor conditions perceived comfortable demonstrably vary with the mean outdoor conditions. (See for example Humphreys’ 1978 graph plotting outdoor monthly temperatures against indoor comfort temperatures (Nicol et al, fig. 3.2.) In daily experience, outdoor lighting levels clearly have an influence: late in the day as it gets dark, the occupant switches on the lights. But we wonder if (as was found with thermal comfort) there are not more subtle connections. In deep winter when the days are short, have occupants acclimatised, and actually require less light for reading a book, and other close-work tasks? We should consider these possible diurnal variations in light comfort levels. In combination with strategies to regulate passive (natural) light and shading (e.g. motorized louvers), we might investigate how base levels of lighting might be varied with the time of day or season; and how localized light sources such as work lamps and reading lights might also be changed.

Our field research described below represents an initial foray into applying the adaptive model to lighting. Thus, we will focus on the first point above (“person-centric and temporally dynamic”), and limit our scope of enquiry to observing at what lighting levels people apply room-level adaptations (i.e. switching on the overhead lights); and then use that information to aid in coarse control of those lights (i.e. simply switching them on or off).

3. Occupant Centered Lighting Control

As a live case study of adaptive lighting for active occupants, we consider an office environment for computer-based work, with offices being occupied by one or two persons, each office being equipped with a passive infrared (PIR) motion sensor and non-dimmable lighting (i.e. the lights can be turned on and off, but not regulated to a certain level).

The general objective is to develop an automated system capable of switching the lights on and off without wasting energy and/or causing discomfort to the occupant. Energy is wasted if the lights are switched on when the occupant is not present or if there is sufficient daylight. On the other hand, discomfort may be caused to the occupant if the lights are suddenly switched off while they are present, and natural light levels are too low. In addition, comfort of the occupant might be better

accommodated if the light is switched on automatically as the office becomes gradually darker, e.g. late in the afternoon.

These ideas might translate into two primary rules for the simple controller in our case study:

1. *switch on lights if someone is present and it is too dark, and*
2. *switch off lights if nobody is present or it is bright enough without lights*

In order to implement these rules, thresholds for presence and light levels must be determined. As has been shown with indoor thermal comfort, a global threshold, i.e. the same for all occupants across a building, tends to provide little support for occupants (whose lighting needs surely vary), and/or tends to be energy-intensive. As a first step towards an adaptive lighting model, thresholds might be estimated for each occupant individually. We describe our approach for this in the following.

3.1 Estimating Light Level Thresholds

Two metrics are possible to characterize the light level in an office environment. On one hand, the *illuminance* (in $\text{cd}\cdot\text{sr}/\text{m}^2$ or lux) refers to the light coming from a light fixture and reaching the workspace, i.e., the desk. On the other hand, the *luminance* (in cd/m^2) is the light leaving the desk. Because the luminance requires an additional characterization of the reflection properties of the workspace, it introduces more variables and hence complexity. In addition, most lighting guidelines are formulated in terms of illuminance rather than luminance. Hence, we choose to consider illuminance as the target variable for determining lighting thresholds. Further, since “workspace illuminance” is our target goal, we propose to measure the vertically incident light at 15cm above desk level (see Section III-A). This is similar to the reference height of 76 cm above the floor, used in defining the recommended office task light levels quoted above (500-1000 lux) (IESNA, 2000).

While PIR-based activation is becoming more common in new buildings, switching lights on automatically based on ambient light is not prevalent. Our goal is to dynamically determine the light level at which the room becomes too dark for the occupant (for either task-based purposes, or for comfort otherwise). To help track this level, we might observe the lighting level at which the occupant actively switches the light on. In this way, we can better understand the temporal, spatial, and personal variations—the end goal being to support the occupant with minimal lighting energy.

In our case study, we monitor the light levels in each office with one-minute temporal resolution, and log the switch on/off events of the user. In a post-processing step, the most recent light level prior to each switch on event is identified. Then, the threshold value is determined as the median of the registered values over a certain period of time. Choosing the averaging window as the past few weeks (for example) allows the threshold to adapt to the occupant’s changing context (e.g. performed tasks, time of year, or use of other sources of light such as a table lamp). Arguably, office-ceiling lights should be switched off if natural illuminance is very high; as a simple approach, we set 1500 lux as the mandatory switch-off threshold.

3.2 Estimating Time Delays

Many office environments have a functionality that switches off the lights after a certain time delay (TD) after the PIR sensor has registered the last motion event. The value ranges usually between 12 and 15 minutes. Lower values might conserve energy, whereas higher values avoid “surprising” occupants by prematurely switching off the lights.

The drawback of a constant TD stems from the fact that the PIR sensors do not register presence but rather motion. Thus, since every person has a different mobility characteristic when working at his/her desk, a sensor might be triggered differently, and small TD values may cause the system to turn off the lights too quickly. In addition, some PIR sensors have high directionality (narrowing their field of observation), and, as a consequence if a person sits in a different location relative to the PIR, it might be triggered differently.

From this, we can conclude that it is necessary to observe the mobility characteristic of the occupant individually. We employ an approach similar to (Garg and Bansal, 2000) by logging the trigger times of the motion sensor. The workings of each PIR sensor may be different, but typically there is an OFF trigger if no more motion has been detected during a certain period of time (set to 1min in our case), and an ON trigger if subsequently motion is detected. The time differences between the OFF and the subsequent ON trigger are used to derive the mobility characteristic of the occupant. After sufficient data has been gathered, the empirical distribution can be determined and the time delay TD can be set such that it covers a large percentage (or probability) of the observed data.

Thus, instead of choosing static time delays, we define target probabilities. This approach has two advantages. First, by regularly updating TD using only recent data, (again, perhaps the past few weeks), the TD can adapt to changes in the activity of the occupant or parts of the office used. Second, even if the same probability value is chosen for all rooms in the building, it will translate into different values for each office based on the mobility characteristic for that particular office. Thus, it adapts to different sensor positioning, rooms, and occupants.

4. Experimental Results

4.1 Measurement and Control Setup

As location for the experimental setup, the authors used their own office building (“HPZ”) on the Hönggerberg campus of ETH Zurich, Switzerland. It was built in the 1970s and completely refurbished in 2011 (see Fig 1a). In particular, it has been equipped with “digitalStrom”, a power line communication (PLC) network especially interesting for retrofit applications, as no new hardware lines have to be installed.

Each device on the network has a unique ID to communicate its status with the main digitalStrom server, the “dSS”. Using a web-API, the dSS allows easy access to the state of the motion sensors, the lighting, and logging the events of the light switches. In addition, lights can be switched on or off. (Dickmann, 2011)

The digitalStrom setup does not measure the lighting levels in the offices, and only offers a limited logging system. Therefore, it has been extended with a customized solution as follows. Each office is equipped with an AMS TSL 2561 digital

illuminance sensor¹, installed about 15 cm above desk level, and measuring the vertically incident light onto the workplace. The sensor is connected to a Raspberry Pi², which communicates with a central control server over LAN. This central server maintains logs of all the events in a MySQL database for data analysis. In addition, the central server acts as gateway to the dSS, which is on a different network due to security reasons. Figure 2 summarizes the networking layers.

The setup has been installed in eight rooms in the building (see Fig. 1b). Out of these, three offices are occupied by two people (G23, G25.2, G26.2), and one is a single-occupant office (G25.1). The others are unique purpose rooms, such as the kitchen (G22), a large meeting room (G27), a large office with varying number of occupants (G24), as well as one workshop (G25.2). With the exception of G22 and G23, which are oriented east, all investigated rooms have a south orientation.

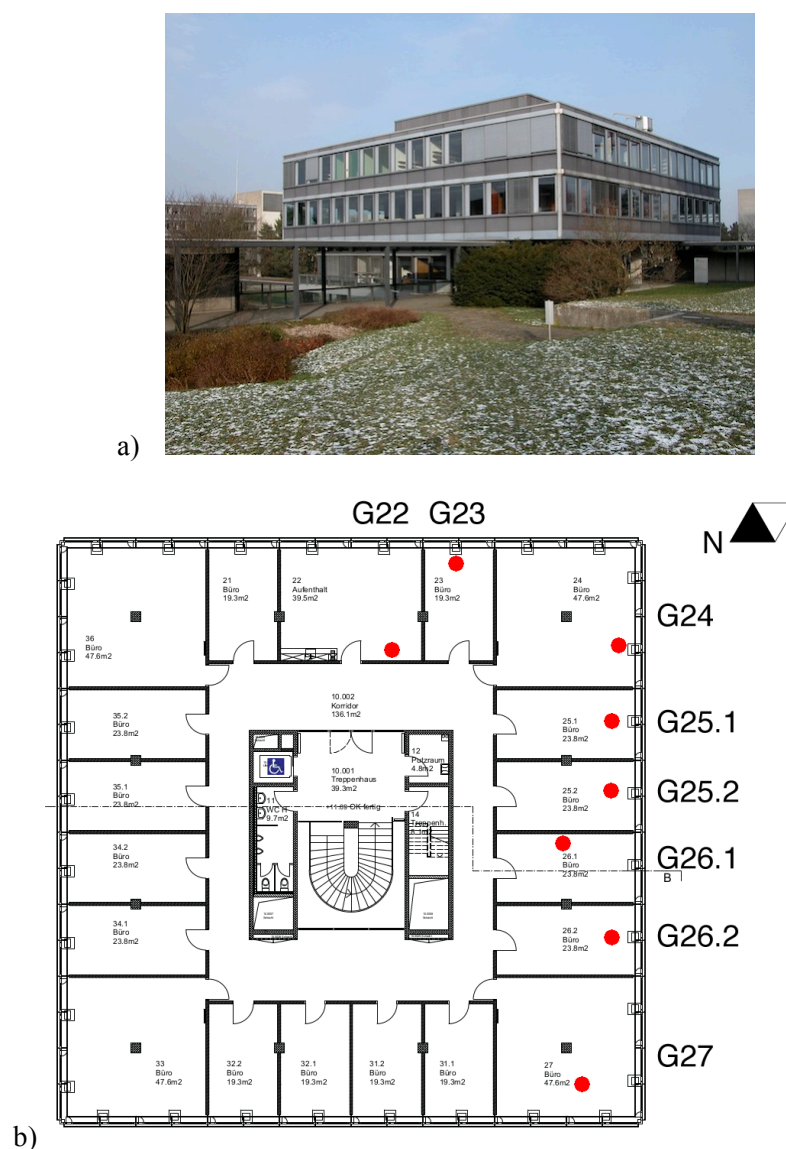

Figure 1. The HPZ building used in this study. a) photo, b) floorplan. Red dots indicate sensor

¹ <http://www.ams.com/eng/AmbientLightSensor>, retrieved January 2014

² <http://www.raspberrypi.org>, retrieved January 2014

locations

The control state/action table is summarized in Table 1. Note that the table only shows conditions, which require explicit action of the controller. In brief, communication between the software is setup as follows. The central server analyses the occupancy and light data daily, and saves current set points for the time delay and the light level threshold. The Raspberry Pi queries this set point from the server, compares them to the current values, and sends appropriate control commands to the server, which then communicates them to the dSS. If the user has switched off the lights, controller action is suspended for 2 hours. This is required to deal with situations, such as darkening the meeting room to use the projector.

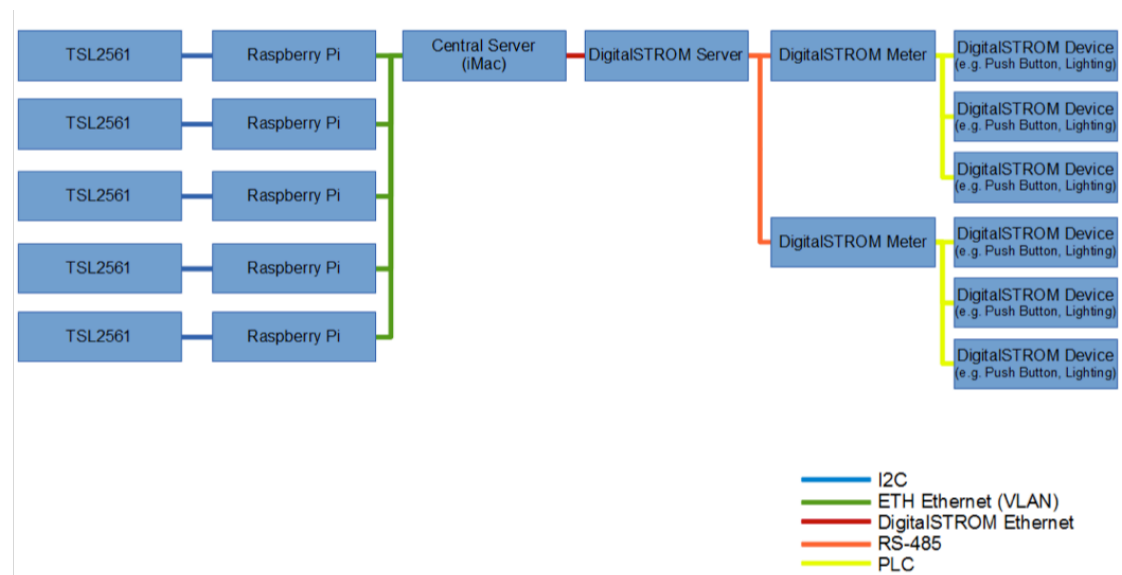

Figure 2. Network architecture

#	States				Controller Action
	Occupied	Lux < threshold	Lights are ON	Lux > bright threshold (1500lux)	Switch Lights
1	No	Yes	Yes	No	OFF
2	No	No	Yes	No	OFF
3	Yes	No	Yes	Yes	OFF
4	Yes	Yes	No	No	ON

Table 1. Summary of control states and actions

4.2 Adaptive Set Points

Figure 3 and 4 shows the distribution of the lighting thresholds in the offices in January 2014. In Figure 3, the data is organized along the time of day, explicitly showing when the thresholds have been generated, while in Fig.4, the frequency count is shown.

We can identify first tendencies from this preliminary dataset. We observe that the largest amount of the data is generated in the kitchen (G22) and the meeting room

(G27), which is not surprising since all members of the research groups on the floor frequent these rooms. In most cases, the data is clustered in two groups, one around 0lux and much higher at 400-500lux. The first group contains the events that most probably occur when the occupant enters a dark office. The second one considers events when the room is getting darker, resulting in the occupant switching on the lights, typically occurring in the afternoon, after 12:00.

We can extract a set point for the control system as the median of the data. To take into account both groups, we show both, the median using all the data, and the median using only afternoon data. Note that the latter will typically be larger than the former since the morning data generates a bias towards lower values. In both, Fig.3 and Fig.4, we can observe that the afternoon median provides a reasonable indicator for the light threshold.

When comparing the determined thresholds, we can clearly observe differences in the individual offices, ranging from as low as 91lux (in G24) to 530lux (G22). This confirms the potential for energy savings and the motivation to use user adapted set points in the control system.

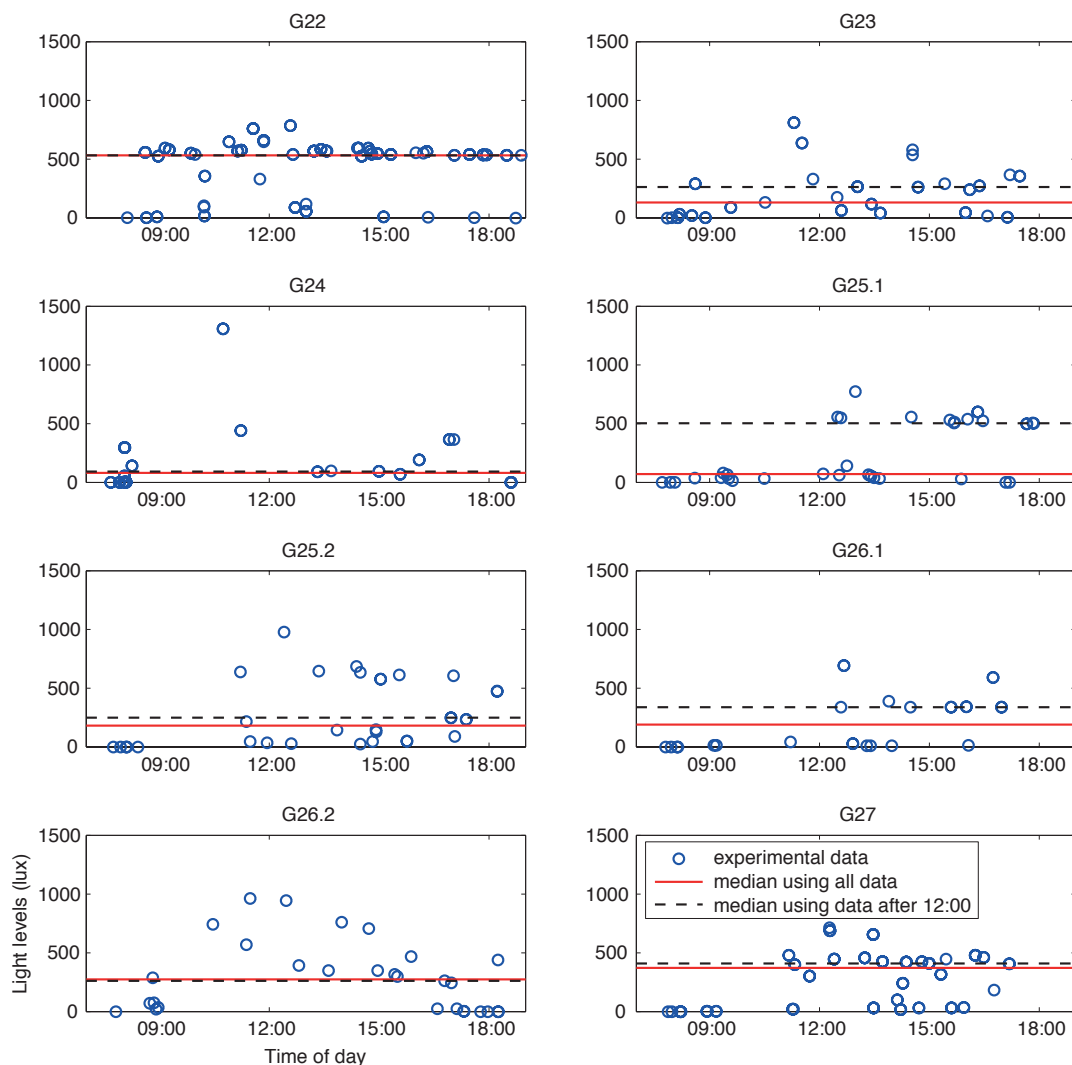

Figure 3. Distribution of registered light level thresholds during the time of day (data for January 2014)

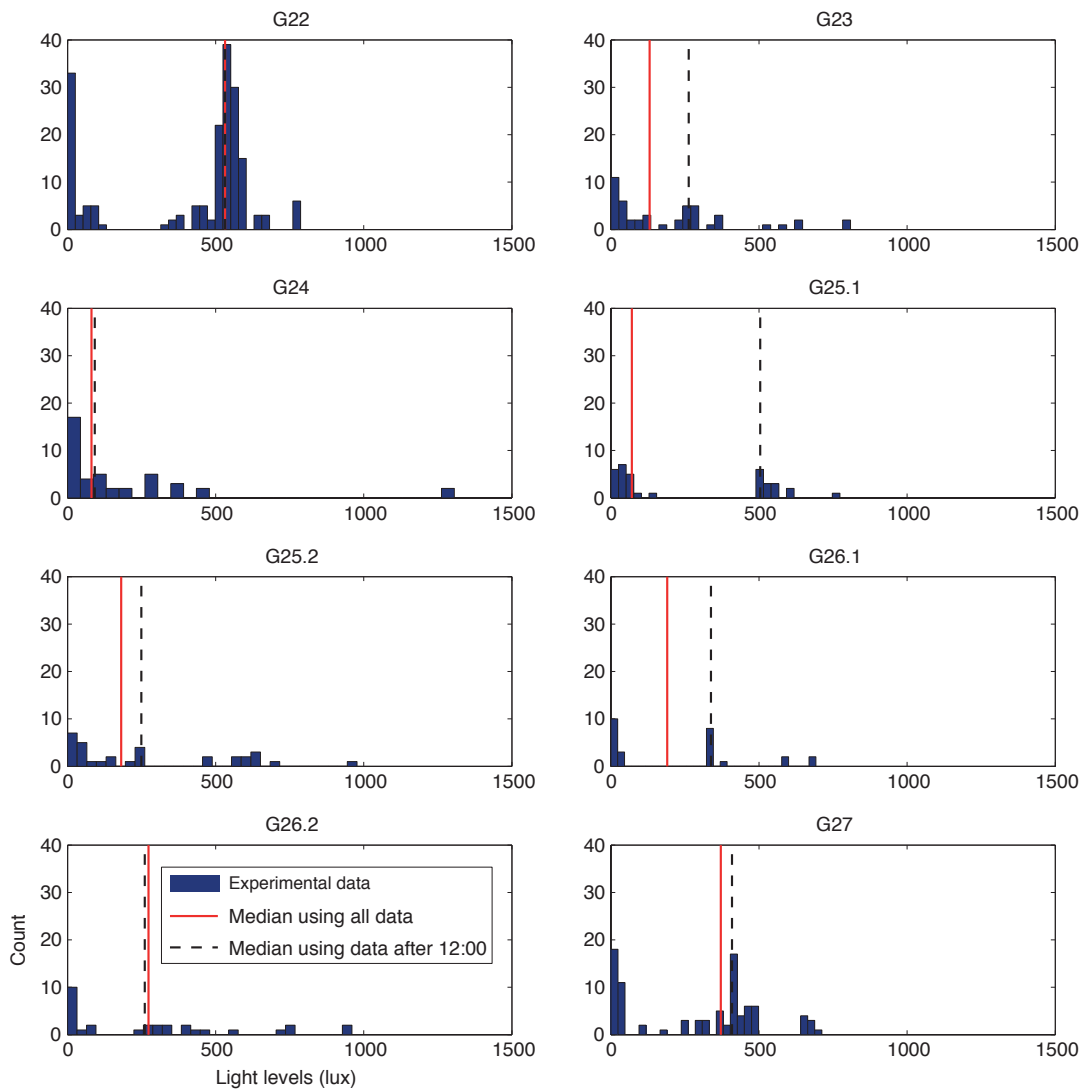

Figure 4. Frequency count of the registered light level thresholds

Next, Figure 5 shows the time delay based on the data from the motion sensor in each office as a histogram, and the resulting empirical cumulative distribution function (ECDF). In addition, we show fits for the generalized Pareto (GP), and the exponential distributions, which are suitable for modeling long-tailed frequency data. The GP fit generally provides the best fit to the data, but comes at the cost of a numerical optimization process. On the other hand, the exponential fit only requires the mean of the data to be computed to estimate its single parameter. Hence, it is more appropriate if computational power is not available.

Even though in our case this is not an issue as data analysis is performed on a desktop computer, we show the implications of using the Exponential fit instead of the ECDF. Notice how small changes in the probability setting can easily lead to over- or underestimation of the ECDF. We find from our data that the best approximation is

provided for $p=0.85$. Further investigation is required in order to heuristically adjust the set points, e.g. if appropriate comfort is not achieved.

For our experiments, we use $p=0.85$ (shown as horizontal line in Fig 5), which, as was the case for the light thresholds, results in a large range of individual set points for each office (vertical lines in Fig. 5). Figure 6 summarizes the light level and the time delay thresholds for each office. Clearly, for both parameters, each office exhibits different thresholds, confirming our premise and motivation for adaptive set points.

As for a first interpretation of the results, concerning the illuminance levels, our data suggests that light levels below the guidelines of 500-1000lux provide sufficient lighting comfort. In addition, the TD set points are mostly under the industry standard of 12-15min. Thus, we can conclude that in both cases further energy savings are possible without compromising human comfort. Of course these claims are limited by the amount of available data. A long-term experimental investigation with proper post-occupancy evaluation will provide more insight.

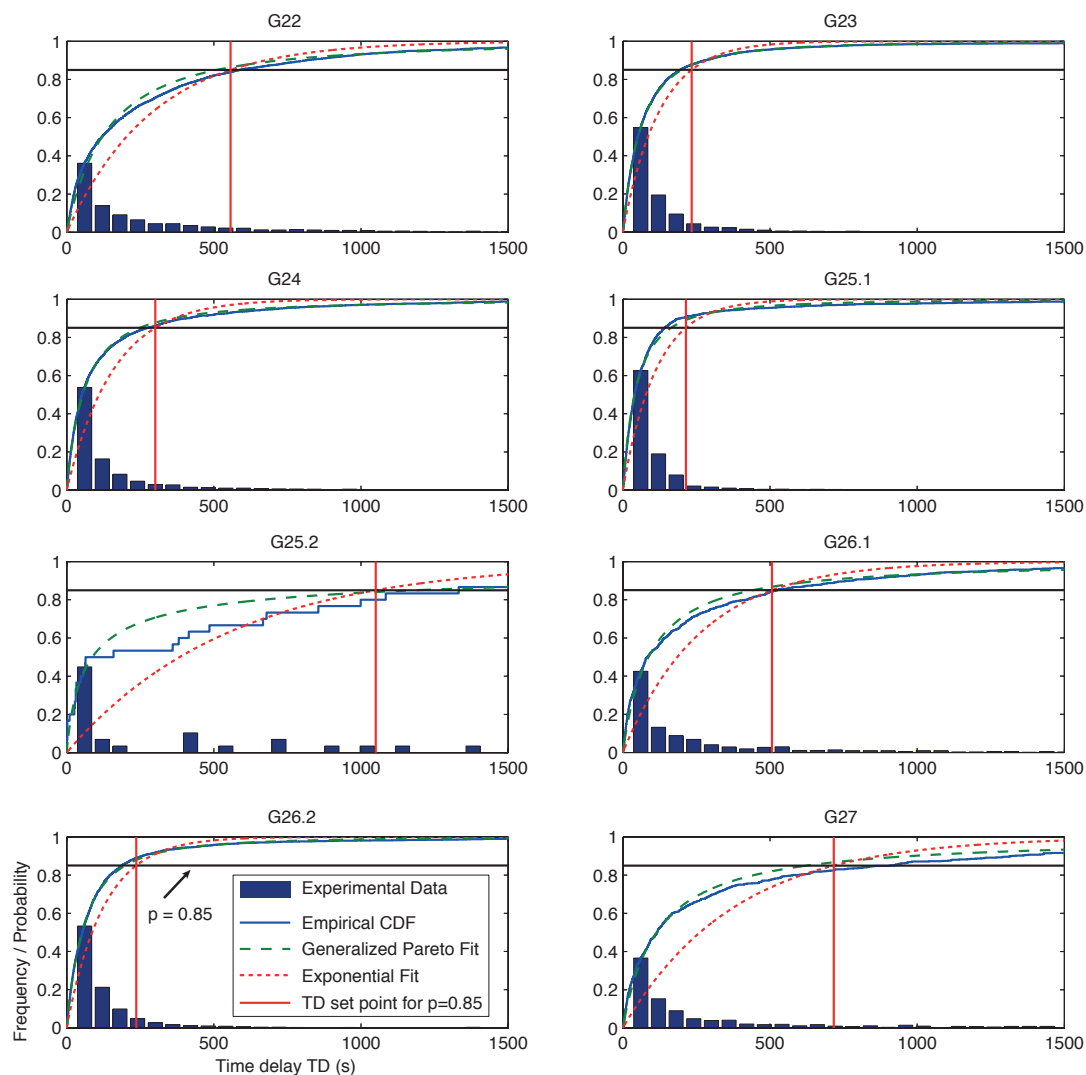

Figure 5. Statistical analysis of the measured time delays, with a histogram of the data (the width of one bin is 60s), the empirical cumulative distribution function, and an exponential and a generalized Pareto fit to the latter. Note how a probability setting of $p=0.85$ creates a

large range of set points in the individual offices.

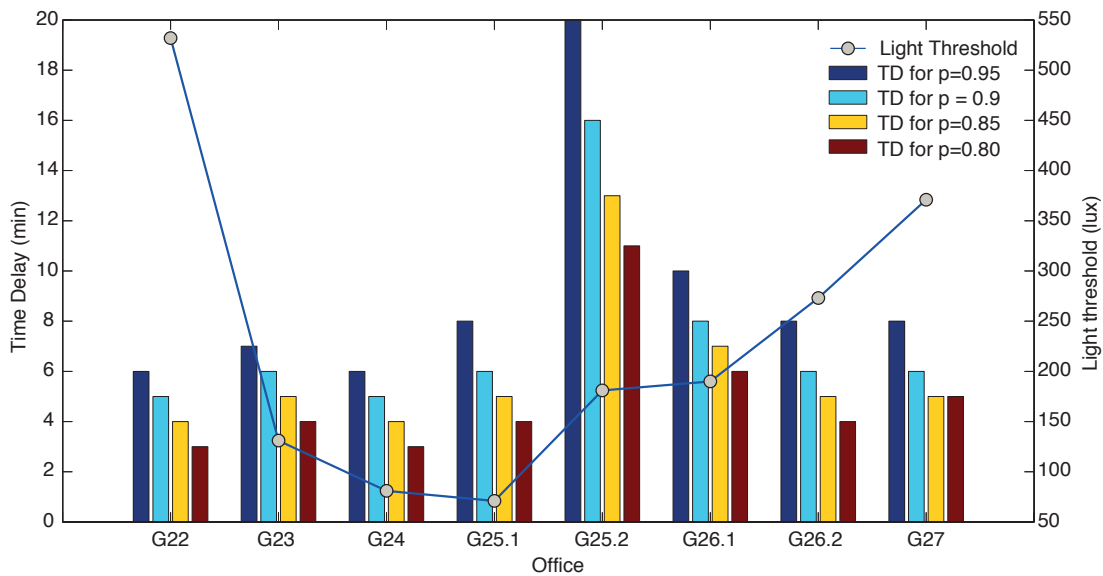

Figure 6. Light level and time delay thresholds in each office. The time delays are given as a function of the probability

4.3 Controller Results

Figure 7 a)-e) shows a typical daily time series of the measured data, captured triggers and controller events. The occupant arrives around 8:00 in the office, which triggers a Switch ON event by the motion sensor because the office is too dark (1). The artificial lighting is turned on, and remains on until the light level in the office is rising above the bright light threshold (1500lux), at which point it is switched off by the controller to save energy (2). At around 16:00, when the light level dropped under the low threshold, the controller switches the lights back on since an occupant is present (3). At around 20:00, the occupant leaves for an extended period of time, and the system switches first the lights Off, and then back on after the returning of the occupant (4). Finally, the occupant leaves the office around 22:00 and switches the lights Off himself (5).

This demonstrates the successful implementation of adaptive lighting control in a live office environment. Comfort might be increased by dynamically adjusting the set-points to the occupant, and by not requiring intermediate switching actions throughout the day. In addition, when possible, energy saving changes are effected by switching the lights off when the office is sufficiently bright.

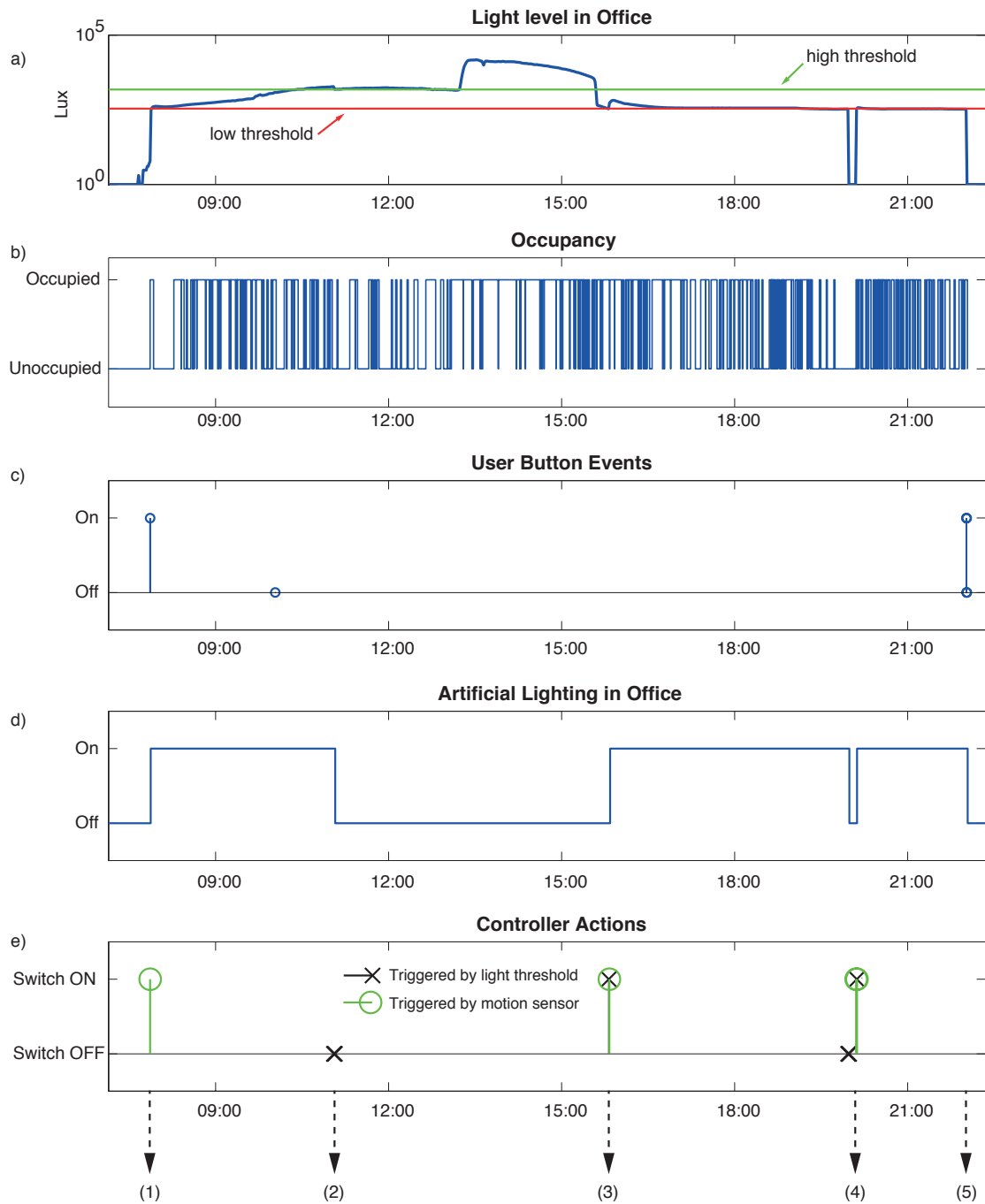

Figure 7. Typical daily data for the implemented adaptive control. a) Measured light levels in the office, b) motion sensor triggers, c) user button push events, d) state of the artificial lighting, e) controller actions. (1)-(5) are events occurring throughout the day, see text for explanation.

5. Conclusions and Outlook

In this research, we argue that in analogy to thermal comfort illuminance targets should vary according to the particular persons, activity, space and time-of-day or season. Such adaptive set points for lighting control have the potential to provide comfort to the occupant while saving energy by adjusting the light levels as necessary. We have implemented a prototype of such a control system in an office environment and determined individual set points for each office based on experimental data. The control system is running successfully in the daily operation of the building and is suitable for long-term experimentation.

Further research will include a post occupancy evaluation to investigate the effects of the automatic adaptation on the occupants. It has been noted that in control systems that interact and adapt to a human occupant, not only the system adapts, but there is also an adaptation process for the human (Mozer, 2005). This can be further explored and investigate whether its possible for example to nudge the user towards more environmental friendly behavior.

An important extension of this research will consider adding more operational flexibility to the lighting, i.e., include desk lighting control as well as dimmable lights. This will add additional possibilities for the control system to maintain a comfortable lighting level. On the other hand, the control task becomes more complex as multiple control actions are possible.

Finally, long term investigation and analysis of the experimental data will allow drawing conclusions whether seasonal or diurnal trends of the light thresholds exist, and can be exploited. Implementing a control strategy based on this knowledge will allow for increased occupant comfort and energy efficiency throughout the year.

References

- Aldrich, M., Zhao, N., and Paradiso, J. "Energy efficient control of polychromatic solid state lighting using a sensor network." SPIE Optical Engineering+ Applications, 2010, pp. 778408-778408
- Clear A, Morley J, Hazas M, Friday A, Bates O. "Understanding adaptive thermal comfort: new directions for UbiComp: new directions for UbiComp". In Proc. ACM Int'l joint conf. Pervasive and ubiquitous computing (UbiComp '13). ACM. 2013.
- Dickmann, G., "DigitalSTROM[®]: A centralized PLC topology for home automation and energy management," (ISPLC), IEEE Int'l Symp. On Power Line Communications and Its Applications (ISPLC) , pp.352-357, April 2011
- Gunay, H.B., O'Brien W., and Beausoleil-Morrison, I. "A critical review of observation studies, modeling, and simulation of adaptive occupant behavior in offices", Building and Environment, Vol 70. December 2013, pp. 31-47, <http://dx.doi.org/10.1016/j.buildenv.2013.07.020>
- IESNA Lighting Handbook. 9th ed. Illuminating Engineering Society of North America, 2000. p. 10-13
- Mozer, M. C. "Lessons from an Adaptive Home", in Smart Environments: Technologies, Protocols, and Applications (eds D. J. Cook and S. K. Das), John Wiley & Sons, Inc., Hoboken, NJ, USA, 2005

- Nicol, F., Michael A. Humphreys, and Susan Roaf. "Adaptive thermal comfort: principles and practice". London: Routledge, 2012.
- Reinhart, C.F., and Karsten V. "Monitoring manual control of electric lighting and blinds." *Lighting Research and Technology*, Vol. 35, No. 3, 2003, pp. 243-258
- Vishal Garg, N.K. Bansal, "Smart occupancy sensors to reduce energy consumption", *Energy and Buildings*, Vol. 32, No. 1, June 2000, Pages 81-87

Light switch behaviour: occupant behaviour stochastic models in office buildings

V. Fabi¹, V. Camisassi¹, F. Causone², SP. Corgnati¹ and Rune Andersen³

¹ TEBE Research Group, Department of Energy, Politecnico di Torino, Corso Duca degli Abruzzi 24, 10129 Torino, Italy

² Energy Department, Politecnico di Milano, Via Lambruschini 4, 20156 Milano, Italy

³ ICIEE, Department of Civil Engineering, Technical University of Denmark, Nils Koppels Allé Building 402, 2800 Kgs. Lyngby, Denmark)

Abstract

It is common knowledge that occupants' behaviour on building control systems plays a significant role to achieve comfortable indoor environmental conditions. Moreover, different research studies have shown how occupants' behaviour also has a huge influence on energy consumption. Consequently, since the building sector still consumes nearly half of the total amount of energy used in Europe and because occupants' comfort should be one of the major aim of a building construction, this influential factor should be further investigated. Reliable information concerning occupants' behaviours in a building could help to better evaluate building energy performances and design robustness, as well as, it could help supporting the development of occupants' education to energy awareness. Concerning occupant behaviour related to indoor lighting systems, many studies have been made regarding occupants' feelings and performances to certain visual stimuli due to different light systems. Nevertheless, occupants' interactions with lighting control systems needs further investigation also because few models to predict switching operations have been implemented in energy simulation programmes. This study proposes probabilistic models to describe occupants' switching on-off control over lighting. They have been developed using a multivariate logistic regression based on measurements of indoor climate parameters, outdoor environmental conditions and artificial lights "switch on/off" actions. Measurements were made over eleven months for three different office rooms. Two predictive light-switch behaviour models were inferred in relation to the number of actions carried out by the users (active or passive). The models are presented and critically discussed in this paper. The study extends the information on environmental parameters influencing occupants' manual control of the lighting system in offices and energy consumption.

Keywords: Occupant's behaviour; light switching; stochastic modelling

1 INTRODUCTION

To predict more realistic energy consumption as well as occupant's comfort requirements, human interaction with buildings and systems should be further investigated. The human behaviour has been studied by several experts from different study branches varying from social science to building science. Researchers tried to describe and forecast occupants' behaviour developing stochastic models based on environmental conditions, named drivers. Different models were carried out on how people adjust blinds, open and close windows, change temperature set point, switch on and off lights (Parys, 2011). The energy saving potential connected with the use of daylight has been the subject of an earlier study, resulting in a broad range from 20% to 80%, according to calculations (Bodart et al., 2002). The research of (Opdal et al., 1995) is of particular interest because calculated energy savings are compared against measurements. A saving potential of about 30% resulted from

measurements, whereas the simulations, without accounting for occupant behaviour, predicted a saving potential of about 40%.

In the study exposed in the current paper, occupants' behaviour towards manual lighting operational system is modelled for the case of office buildings. The aim is to enlarge the knowledge about indoor and outdoor environmental conditions influencing people's behaviour, as well as to predict their impact on electric energy use in buildings. The statistical models were inferred over field measurements recorded from an office building located in Prague for more than eleven months.

2 METHOD

In literature the main factors which influence the behaviour of occupants related to the light switching in office buildings are reported (Fabi et al., 2013). Models were developed following consolidated proposed methodology (Fabi et al., 2013), switching from standardized and deterministic methodologies, toward a probabilistic approach in energy modelling. Behaviour patterns for active and passive occupant's typologies were analysed in order to determine the influencing factors leading the office occupants to switch ON/OFF the lights. Some of the factors identified in the literature were then quantified in this study by means of long-term monitoring of behaviour and environmental variables in three offices, resulting indifferent user models, suitable to be implemented in an energy simulation software.

3 THE FIELD SURVEY

Data on light switching operations were gathered with a measuring campaign in eight identical offices of the Czech Technical University (CTU) in Prague within the framework of the EU Project "Clear-Up". Environmental parameters useful to model light-switching behaviour were monitored in two single offices (in the following called Room 2 and Room 5) and one shared office (in the following called Room 3).

The lighting equipment installed in the rooms is characterized both by manual and automatic control. Occupants can operate manually over each control with an individual pair of up/down buttons as summarized in Table 1.

Table 1. Summary of the possible operations over roller blinds, ceiling and floor standing lights.

	Roller Blinds	Ceiling light	Floor standing light
short	step move up/down, stop while moving	manual on/off	on/off
long	Move up/down completely		dimmer

The automatic system varies for each component. The ceiling light band and the floor standing lamp are controlled by a presence detector. In fact, after a configurable time period of non-occupancy (set to 15 minutes), the lights switch off automatically, while on re-occupancy, the system resumes lighting settings. The floor standing lamp can be, furthermore, constantly controlled with an integrated manual and dynamic set-point system. The automatic operation of the ceiling lights, which is triggered by the presence detector, was not implemented when the measures were taken, and so it was possible to analyse the data when the overhead lights were switched on and off manually.



Figure 1. Installed sensors in office rooms.

Moreover, a series of variables concerning indoor and outdoor environmental conditions were monitored from February 2012 to January 2013.

The following variables were measured at 5 minute intervals in all 8 offices:

- | <i>• Indoor environment parameters</i> | <i>• Outdoor environment parameters</i> |
|--|---|
| - Temperature [°C] | - Air temperature [°C] |
| - Set-point temperature [°C] | - Relative humidity [%] |
| - Relative humidity [%] | - CO ₂ concentration [ppm] |
| - CO ₂ concentration [ppm] | - VOC concentration [ppm] |
| - VOC concentration [ppm] | - Wind speed [m/s] |
| - Illuminance (in the middle of the room,
on desk, at window) | - Rain (yes, no) |
| | - Wind speed [m/s] |

Since several studies (Hunt, 1979, Love, 1998, Reinhart, 2001) demonstrated that occupants' actions on lighting are strictly connected to the fact that people are entering or leaving the space, the time of presence was included as possible behavioural influencing factor besides the measured variables. Considering Hunt's results, the authors settled the arrival period and the departure period as the first and last 15 minutes, when occupancy is recorded. The other period of occupancy was called intermediate (Table 2). Furthermore, previous studies on occupants' behaviour over lighting system already proposed a connection between the large spatial brightness gradient within the room and the use of artificial light (Halonen and Lehtovaara 1995, Begemann et al. 1997), consequently, the illuminance uniformity was derived in this case as a ratio between the lux levels measured by the sensors. The azimuth and elevation angle for the specific location were evaluated from the website http://www.sunearthtools.com/dp/tools/pos_sun.php?lang=it.

A stochastic model was developed from this data for the three rooms representing three different behavioural models.

3 STATISTICAL MODELLING

In the analysis the probability of switching on and off the lights was inferred for three behavioural models. The statistical software R was used for all data analysis and modelling.

The collected data shows that the users did not use the lights very much. It is interesting to see that the room with a lower occupational rate, presents the higher number of action over the light system. Generally this database confirms the findings of previous studies (Hunt, 1979, Love, 1998, Reinhart, 2001): the majority of switch on actions are taken when people arrive in the office. The collected data shows how the ceiling light stays on, even after the occupants leave the rooms: for Room 2 this condition happens for the 37% of time of the whole period during which the light is on, and it happens even more for the other two rooms (42% room 3, and 46% room 5). It also emerged that quite often the lights are turned off on arrival in the room (Table 2). It is interesting to see that this event happened more often in Room 2 than Room 3 and Room 5 (respectively 19%,17%,15%), and it means that the occupants of Room 3 and Room 5 left the light on for longer periods (not more often), and they might have not turn off the light suddenly at their arrival (Table 2).

Table 2. Actions on lighting related to the moment of presence

	Room 2			Room 3			Room 5		
	Arrival	Departure	Intermediate	Arrival	Departure	Intermediate	Arrival	Departure	Intermediate
Switch ON	102		22	10	1	1	18	0	9
Switch OFF	23	52	49	2	6	4	4	13	10

Switch off actions show high readings also during the intermediate moment of presence (Table 2), when users remain for long periods inside the office.

The database was divided depending on the state of the light (on/off) to infer the probability of switching on or off separately (the change from one state to another). Moreover, given the number of actions collected and the occupancy pattern, the users of the three rooms were divided into two groups:

- Active: representing an occupant profile that use frequently artificial light.
- Passive: representing an occupant profile that use less frequently artificial light.

Consequently, different models were built considering the data all together and the two categories separately. The monitored occupant' actions are summarised in Table 3:

Table 3. Actions on lighting related to the two categories moment of presence

	active models	passive models
SWITCH-ON	120	37
SWITCH-OFF	122	39

Occupant' actions on the control system were obtained by mean of logistic regression with interaction between variables accordingly to the following equation:

$$\text{Log} \frac{p}{1-p} = \beta_0 + \beta_1 x_1 + \beta_2 x_2 + \dots + \beta_n x_n + c_{12} x_1 x_2 + c_{13} x_1 x_3 + \dots \quad (1)$$

Where:

p is the probability of a switching on/off event

β_0 is the intercept

β_{1_n} are coefficients

x_{1_n} are explanatory variables such as illuminance, room temperature

c_{12_nm} are interactions coefficients

Backward and forward selections, based on the Akaike information criterion were used to infer the models. The AIC criterion was applied because it evaluates the relevance of each individual variable as well as the amount of parameters included by the model, decreasing the risk of over fitting (Schweiker and Shukuya, 2009).

In order to limit the complexity of the model, only interaction between continuous and categorical variables (e.g. lux level and moment of presence) was investigated. In particular, the categorical variables used to investigate correlations among parameters were: the time of presence (arrival/intermediate/departure period), the door switching and the room indicator.

The analysis results were models able to predict probabilities of turning on and off the lights, and they confirmed that there is not a unique valid model to characterize the user and its behaviour, but only a dedicated model according to the used database and goal of the analysis. The scales of the variables was taken into account: Schweiker and Shukuya (2009) suggested to multiply the scale of the variable with the coefficient, to get an indication of the magnitude of the impact from each variable.

Logistic regression requires independent variables. Specifically, two kinds of correlations were taken into consideration: variables should be independent from the office they were recorded in and among each other. In this case, lighting variables still had high dependency between each other because some of them were inferred from the other. To overcome this problem, models were inferred with diverse explanatory variables and, also in this case, the different models were selected using AIC criterion. Its use was assumed reasonable because the model were developed from almost the same subset of database.

These preliminary cautions depend on the fact that correlations between explanatory variables might result in inflation of the estimated variance of the deducted coefficient and consequently in too wide confidence intervals. Confidence intervals were considered to assess the significance of the models and generalized variance inflation factors (GVIF) were calculated for coefficients of all explanatory variables to estimate the size of the inflation due to multi-co linearity among all explanatory variables.

4 RESULTS

Stochastic models estimate how an occupant's action varies as a function of the different independent variables. It can reasonably be assumed that occupants make actions just when they are in the room, so when the presence detector records the occupancy of the space. For this reason models were built considering only time-steps when occupant presence is observed. The main variables resulted as influencing factors for the three different models are presented in Table 4 and in Table 5 with their magnitudes.

Even if the statistical analysis include the interaction terms among the variables, it results that selected models do not present any reciprocal influence among the considered factors.

The confidence intervals reveals that the majority of the variables selected in the models are significant. Only the time of presence in the active switch-on model presents inflated intervals. Obviously, the departure period displays a lower significance (-975.04 – 944.09) as well as the intermediate time (-2,63 – 2.76). Nevertheless, even the arrival period do not result significant (-1,39 – 3.88).

Table 4. Influencing factors for energy-related behaviour with respect to switch ON/OFF lights for the investigated offices.

<i>Influencing factor</i>	<i>Light switch on</i>		<i>Light switch off</i>	
	<i>Active models</i>	<i>Passive models</i>	<i>Active models</i>	<i>Passive models</i>
<i>Moment of presence</i>	x	x		X
<i>Illuminance at the windows</i>	x	x		
<i>Illuminance in the middle of the room</i>	x	x	x	
<i>Indoor temperature</i>	x			x
<i>State of the floor lamp</i>	x			x
<i>Elevation</i>	x			
<i>Illuminance ratio between ill. in the middle of the room and on the desk</i>			x	x
<i>Azimuth</i>				x

Table 5. Magnitudes of resulting influencing factors for energy-related behaviour with respect to switch ON/OFF lights for the investigated offices.

<i>Influencing factor</i>	<i>Light switch on</i>		<i>Light switch off</i>	
	<i>Active models</i>	<i>Passive models</i>	<i>Active models</i>	<i>Passive models</i>
<i>Illuminance at the window</i>	-2.46	-3.36		
<i>Illuminance in the middle of the room</i>	2.82	3.84	-10.76	
<i>Indoor temperature</i>	-2.59			8.58
<i>State of the floor lamp</i>	-4.08			-4.92
<i>Elevation</i>	-4.13			
<i>Illuminance ratio between ill. in the middle of the room and on the desk</i>			5.20	5.35
<i>Azimuth</i>				-2.30

4.1 Active-user models

The daylight from the window, the room temperature, the dimming state of the floor standing light and the sun elevation were negatively correlated with the probability of switching on the ceiling lamp (figure 2). In fact it is reasonable to assume that the rise of this variable will reduce the odds of action over ceiling light. A higher indoor temperature presumably could be related to a warmer season with higher daylight levels (offices were not provided with cooling devices). The illuminance in the middle of the rooms, resulted, unexpectedly, a positive correlation: the probability increased when the lux level increased.

Sun elevation got a higher influence over switch on probability than lux level at the window, even if the two variables are strictly correlated (figure 2).

The time of presence influence on probability has been already defined in previous studies (Mahdavi et al., 2008; Reinhart 2004): it is higher when people arrive in the office while lower for departure and intermediate periods even if they result not significant coefficients with wide interval of confidence. Concerning the switch-off model, the main drivers resulted to be the illuminance in the middle of the room and the uniformity. The result is quite surprising as in previous researches (Pigg et al. 1996, Mahdavi et al. 2008) the chance of switching off actions were not related to lighting environmental conditions, but only to users presence patterns (specifically absence length was considered the main parameter that drives people to turn off the light).

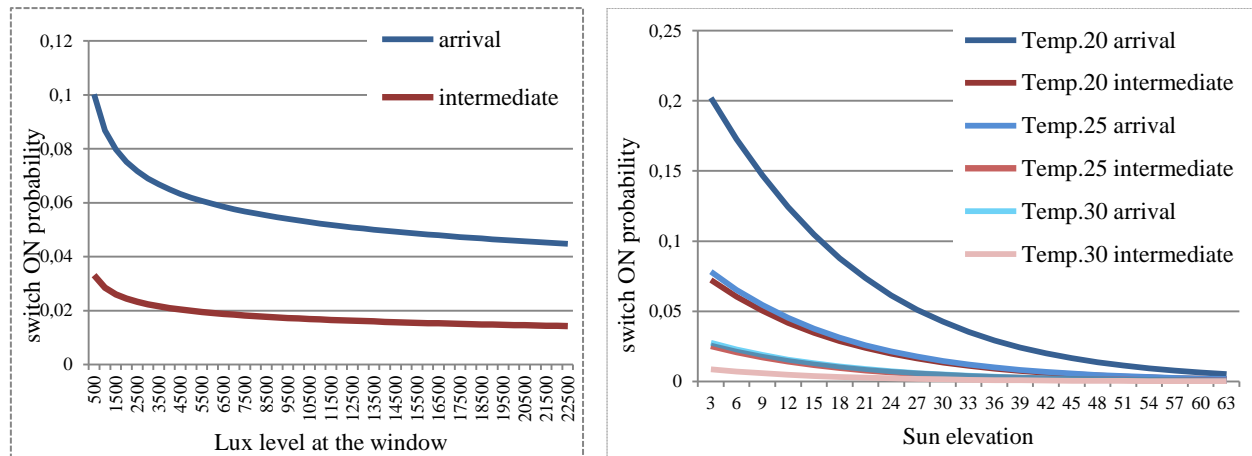

Figure 2. Switch-on probabilistic curves for active users related to different drivers (lux level at left and sun elevation at right)

4.1 Passive-user model

The switch-on model built from the data of the rooms occupied by what the authors defined as “passive” users, are characterized by a lower number of drivers than the active one. Only the illuminance is included with the same condition: the increase of illuminance level will diminish the probability of switch on action over the ceiling lamp while the illuminance inside is unusually positively correlated instead. Besides the continuous variables, the moment of presence affects the model with less significance in relation to the departure period. Only the uniformity parameter is included in switch-off model as lighting parameter. Even if its importance is quite high for the model according to the magnitude, it is not easy to determine its influence. In this case the uniformity was determined vice versa, since higher values were measured in the middle of the room than over the desk and more often they were higher than 1, meaning that higher ratio values do not definitively infer a better uniformity. Room temperature, the state of the dimming floor standing light and the azimuth were the other continuous variables that affected the model.

5 DISCUSSION

Generally, all the probabilities inferred by the various models show really low values (figure 2). It depicts of course the conditions emerged from the preliminary observation: people are not used to act over lighting system. This will reflect in low energy consumption related to lighting system, but in any case it represent a real condition.

From all the models it emerges that the users’ behaviour is influenced by a superior number of parameters than the one presented in literature. In fact, even taking into account the most simplified switch-on model, two other environmental conditions are used to infer the probability of action: indoor temperature and sun elevation. Nevertheless, they represent two

other parameters related to daylight in the indoor space. Unfortunately, the daylight at the work plan, which is the main variables for the existing models (Hunt 1979, Reinhart 2001, Mahdavi et al. 2008), could not be included as a variable. Despite this limitation, the illuminance at the windows is displayed with a negative correlation in accordance to previous studies. On the contrary, higher lux level in the middle of the room increase the probability to turn on the light. This dissimilarity could probably deal with the presence of the floor standing lamp which influenced of course the illuminance measurements.

Switch-off models also recorded much more variables. Pigg et al. (1996) and Mahdavi et al. (2008) defined that the turning-off action over light was mainly related to the absence length of occupants. Here instead, occupant's actions are influenced by both lighting variables and the period factor. Nevertheless the absence length was not included as a possible factor so it is not possible to evaluate if it represents the main stimulus. A very surprisingly, as well as note-worthy, aspect is that occupants' behaviour over lighting system never results to be affected by the blinds' state. Haldi (2010) enhanced the possibility of interaction between the two systems that both imply occupants' action in his study and Reinhart (2004) added this relationship a priori in his model. However this condition does not result in this research and it might also mean that this strong relationship is well known by experts in the field but actually not adopted by real users, even if they are people of a high social education standard (civil engineers).

Another consideration regards the facts that all the switch-off models display a negative intercept while for the switch on models is always positive. This condition illustrates that users are more used to turn on lights than switch them off. They get the stimulus to turn on the light due to poor visual comfort while its non-necessity normally does not drive to turning off. They might not perceive its uselessness or are simply unwilling to operate the action since the controller is far away from where they are. This situation underlines how important it is to inform and educate people in relation to this matter.

6 CONCLUSIONS

Different behavioural models related to occupant preferences on artificial lighting were inferred from data gathered during a monitoring campaign in an office building. It was evaluated the probability that an action (switch on or off) may occur for different behavioural models (Active and Passive users), defined on the basis of the number of actions on occupational periods. From the resulted models it emerged that users' behaviour is influenced by many parameters, representing a step-forward with respect to the previous studies. In fact, even taking into account the most simplified switch-on model, two new environmental parameters are used to infer the probability of action: indoor temperature and sun elevation. It was understood that users are more used to turn on lights than to switch them off. This situation underlines how important it is to inform and educate people in relation to this topic.

A further point to specify is that the presence of active users does not imply less energy consumption: their chance to turn off the light is higher but also to switch it on. For this reason it is necessary to implement the model in energy simulation software. Expanding knowledge of the explanatory environmental conditions may help to better understand human comfort needs and habits, and their implementation in energy simulation software, will allow to better understand the impact of occupants' behaviour on energy consumption as well as on building indoor comfort.

References

- Bartoňová J., M.Kabrhel, K. Kabele, simulation of the impact of pcm plasters on thermal comfort and indoor environmental quality in offices <http://www.clear-up.eu/>; http://www.sunearthtools.com/dp/tools/pos_sun.php?lang=it
- Begemann S.H.A., Van den Beld G., Tenner J.A.D.,(1997) Daylight, artificial light and people in an office environment, overview of visual and biological responses. *Industrial Ergonomics* 20: 231–239.
- L. Halonen, J. Lehtovaara, (1995) Need of individual control to improve daylight utilization and user satisfaction in integrated lighting systems. Proceedings of the 23rd Session of the CIE, New Delhi, India, Vienna, Austria: CIE, 200–203.
- Bodart M., De Herde A. 2002. Global energy savings in office buildings by the use of daylighting, *Energy and Buildings* 34, pp. 421-429.
- Fabi V., Influence of Occupant's behaviour on indoor Environmental Quality and Energy Consumption, [Doctoral Dissertation] Torino: Politecnico of Turin, 2013.
- Haldi F., Towards a Unified Model of Occupants' Behaviour and Comfort for Building Energy Simulation [Doctoral Dissertation] Lausanne: Ecole Polytechnique Federale de Lausanne, 2010.
- Hunt D.R.G., (1979), The Use of Artificial Lighting in Relation to Daylight Levels and Occupancy . *Building and Environment*, 14: 21-33.
- Love JA., (1998), Manual switching patterns observed in private offices. *Lighting Research and Technology*, 30: 45-50
- Mahdavi A., Mohammadi A., Kabir E., Lambeva L., (2008) Occupants' operation of lighting and shading systems in office buildings. *Journal of Building Performance Simulation*, 1 (1): 57-65.
- Opdal K., Brekke B. 1995. Energy saving in lighting by utilization of daylight, Proceedings of Right Light 3, pp. 67-74.
- Parys W., Saelens D., Hens H., (2011) Coupling of dynamic building simulation with stochastic modelling of occupant behaviour in offices – a review-based integrated methodology. *Journal of Building Performance Simulation*, 4(4): 339–358.
- Pigg S., Eilers M., Reed J., (1996), Behavioural aspects of lighting and occupancy sensors in private offices: a case study of a university building. Proceedings of the 1996 ACEEE summer study on energy efficiency in buildings
- Reinhart C.F., Daylight availability and manual lighting control in office buildings – Simulation studies and analysis of measurements [Doctoral Dissertation] Dusseldorf: University of Karlsruhe, 2001.
- Reinhart C.F., (2004) Lightswitch-2002: a model for manual and automated control of electric lighting and blinds. *Solar Energy*, 77 (1):15-28
- Schweiker M, Shukuya M., (2009), Comparison of theoretical and statistical models of air-conditioning-usage behavior in a residential setting under Japanese climatic conditions. *Building and Environment*, 44: 2137-49.

Towards a Dynamic Daylight Understanding

Isabelle Leysens¹, Ulrike Passe²

1. Center for Building Energy Research, Iowa State University, United States. ileysens@iastate.edu

2. Center for Building Energy Research, Associate Professor of Architecture, 491 College of Design, Iowa State University, United States. upasse@iastate.edu

Abstract

Daylighting is still the most energy efficient lighting strategy, but filtering sunlight might conflict with maximization of solar gains in winter or reducing solar heat gain in summer. In passive solar homes occupants ideally balance visual and thermal comfort. This study explores the relationship of daylight and thermal comfort in a passive solar home using an extended case study method. The resulting daylight measurements reveal a significant tolerance for fluctuations in natural illumination, lower than both high and low thresholds used by emerging dynamic daylight metrics such as IESNA Lighting Handbook, Useful Daylight Illuminance, and CIBSE lighting recommendations. Minimal evidence of electrical lighting use revealed that passive solar occupants have learned to modify the house to receive sufficient daylight while maintaining a comfortable thermal environment. As a result, a preliminary dynamic visual comfort zone is identified, which presents the notion of a metric that includes occupant illumination control.

Keywords: Daylighting, Thermal Comfort, Passive Solar Architecture, Daylight Simulation, Metrics

1. Introduction

Daylighting can easily become one of the most difficult tasks in architectural design. Upon gaining a basic understanding of natural illumination, it becomes clear that a range of ever-changing variables must be accounted for. Additionally, what is considered to be the definition of daylighting and its benefits vary greatly between engineers, designers, and energy consultants (Reinhart et al, 2006 p. 8). The resurgence of dominantly glass facades in recent green constructions would suggest movement towards a more effective balance of daylighting and energy efficiency, but comprehensive energy assessments reveal that popular daylighting strategies are still creating issues of thermal comfort, and therefore affecting both energy efficiency and occupant satisfaction (Konis 2012). Passive solar architecture seeks to design for complete building performance through the consideration of appropriate seasonal treatment of both daylight and solar heat gain.

Historically, when the glass facades of the mid-century became problematic for energy consumption, architects attempted to combat the sun's negative effects by blocking it from entering buildings entirely. This approach soon proved too antithetical, resulting in sealed spaces with negative effects to occupant health. Studies of occupant responses to daylight in contemporary work environments have revealed a number of psychological, aesthetic, and sustainable benefits provided by the reintroduction of daylight as a design priority (Galasiu et al, 2006). Acknowledgement of the positive influence of daylight

has placed it as a consideration to architects, but issues of glare and solar heat gain still remain as a hindrance. In addition, the lack of standardization towards natural illumination requirements means that these advantages are not guaranteed in all new constructions. Only those seeking LEED accreditation are subject to the new emerging dynamic daylighting metrics in the US, which aim to insure both quality and performance through the implementation of large datasets and CAD software (Reinhart et al, 2006).

Although new daylighting design software can be an important aid in achieving effective daylighting, the basic schematic design still carries the greatest impact on the success of a effectively daylit space (Tragenza 2011, p. 77). New daylight metrics such as Daylight Autonomy and the Useful Daylight Illuminance promote the notion that daylight is not static, and buildings must be designed with consideration of the natural occurrences (such as climate, surrounding buildings, etc) from the beginning of schematic design. While these factors make up a large component of accessible effective daylighting design, but the operation of the building plays a significant role in the energy performance (Pilkington et al, 2011 p. 4962).

It has been suggested that the effectiveness of current daylight design strategies that meet daylighting metrics still produce uncomfortable interior conditions due to the scarcity of post-occupancy evaluations of daylighting (Konis 2012, p. 344). Various studies have been conducted which evaluate occupant responses to daylighting using a range of existing buildings (Reinhart et al, 2011, Jakubiec et al, 2011, Boyce et al, 2003, Nicol et al, 2006), but many times the buildings in question were initially designed with active mechanical systems in place. This following study examines occupant response to daylighting using a passive solar case study building to evaluate the impact of daylight on occupant satisfaction and thermal performance. By using occupant comfort as a lens for examining the way in which daylight and thermal comfort interact, effective design and operation strategies can be identified for all daylit buildings.

2. Terms

2.1 Daylight Autonomy (DA)- This climate-based metric currently implemented in LEED v4, is “defined as the percentage of occupied times in the year during which minimum, program-specific illuminance levels can be met by daylight alone.” (Reinhart et al 2012, p. 156). Illuminance levels are set in a daylight simulation computer program, using daylighting recommendation such as the German standard (DIN 3035) or the Illumination Engineering Society of North America (IESNA) Lighting Handbook (Reinhart 2014)

2.2 Continuous Daylight Autonomy- a recently proposed metric that identifies the percentage of illuminance in relation to the Daylight Autonomy upper threshold (Rogers 2006)

2.3 Useful Daylight Index (UDI)- A dynamic daylighting metric defined as “the annual occurrence of illuminances across the work plane where all the illuminances are within the range of 100-2000 lux” (Nabil et al, 2004 p. 41)

2.4 Successful Daylight- This particular study uses thermal comfort conditions in order to identify visual comfort parameters. Therefore, occupant comfort is treated as a composite of visual and thermal comfort, in order to acknowledge the reciprocal nature of illumination and temperature in passive solar design. Daylighting in this paper is defined as “a space primarily lit with natural light and that combines high occupant satisfaction with the visual and thermal environment with low overall energy use for lighting, heating, and cooling (Reinhart et al 2010, p. 4). It is assumed that any successful daylight is achieved through both architectural design and individual occupant adjustment to the illuminated space.

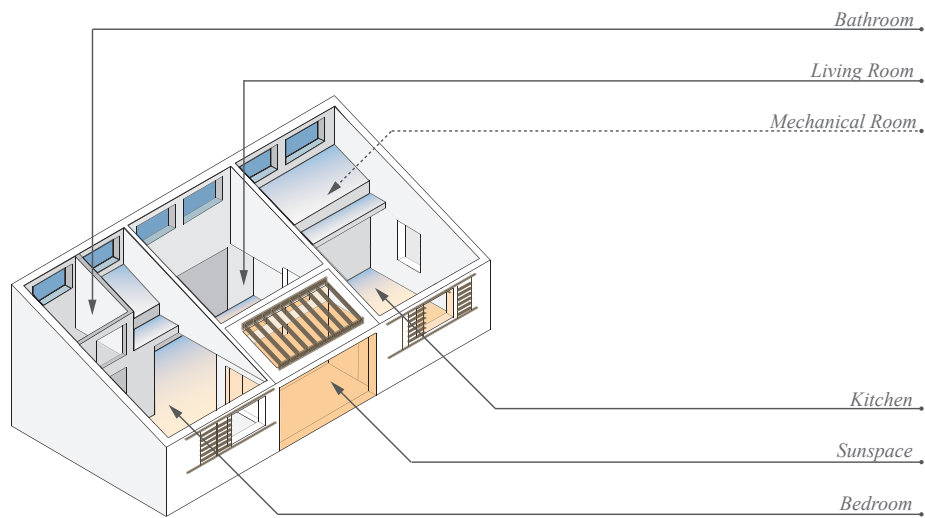

Figure 1. Interlock House architectural axonometric

2.5 Daylight Factor (DF)- The most basic and widely used daylighting metric, which gauges sufficient daylight by calculating “the ratio of the illumination indoors to outdoors on an overcast day (Lechner 2009, p. 390). This metric only provides a rough illumination estimate, due to a lack of consideration for specific outdoor climate conditions.

2.6 Thermal Comfort - Thermal comfort in this study is defined using the Adaptive Thermal Comfort definition of “a comfortable thermal state, or the study of processes and conditions that produce or fail to produce comfortable thermal states” (Nicol 2002, p.164).

3. House Introduction

3.1 Architectural Design

This exploratory research makes use of a single case study passive solar house, which is currently being occupied by two naturalists as an office. Originally built in 2009, the 800 sf house was designed and constructed by an interdisciplinary team of students at Iowa State University for the US Department of Energy Solar Decathlon Competition. A sunspace sits in the center of the floor plan, which provides solar heating for the house in the winter and promotes natural ventilation in the summer using operable glass walls. The sunspace floor acts as a thermal heat sink, and evacuated solar tubes on the roof collect solar energy to provide radiant floor heat. The house is naturally illuminated through a multi-part scheme of dispersed sunspace light, direct southern exposure, and ambient northern windows. Southern light is controlled using exterior louvers as well as interior Roman shades. Northern light is projected into the space through large clerestory windows as well as a combination of a sloped roof and light shelves. Finally, the house floor plan is composed of a series of interlocking spaces that allow for light and air to flow freely throughout, hence the name Interlock House.

3.2 Data Collection

In 2009 the Iowa Department of Natural Resources purchased the Interlock House from Iowa State University to act as an activity center and naturalist office at an Iowa state park. The house was reconstructed with the addition of a data monitoring system comprised of 95 hard-wired sensors, allowing the Iowa State University Center for Building Energy



Figure 2. Building Exterior

Research team to study post-occupancy performance. The flow of water, electricity, air, and light are monitored year round by researchers to study correlations between occupancy, design, and performance.

3.3 Context

In 2009 the Iowa Department of Natural Resources purchased the Interlock House from Iowa State University to act as an activity center and naturalist office at an Iowa state park. The house was reconstructed at the park after the Solar Decathlon, with the addition of a data monitoring system comprised of 95 hard-wired sensors. Sensors now allow the Iowa State University Center for Building Energy Research team to study post-occupancy performance. The flow of water, electricity, air, and light are monitored year round by researchers to study correlations between occupancy, design, and performance.

3. Occupancy Introduction

In its current use the Interlock House acts as a naturalist center, where guests to the state park are able to visit for activities geared towards local wildlife education. A varying number of guests circulate through the building during a 4-hour window for 5 days of the week. Three occupants consistently use the building as an office, while 6 turtles and 2 snakes live in enclosures year-round inside the house. Figure 1 further illustrates the post-occupancy inhabitation effect on the basic architectural design.

The 3 permanent occupants of the Interlock House originally brought the quality of daylight to the attention of Iowa State researchers. After roughly a year of working in the house, the electrical lighting had been rarely used during normal office hours. Researchers had been collecting desk surface illumination during this time, which upon closer examination were established to be not meeting pre-design simulation measurements (Leysens et al, 2013, p. 5). This observation prompted the need to develop a research study, including a collection of qualitative occupant feedback so quantitative measurements could be identified and paired with illumination measurements considered to be ‘comfortable’.

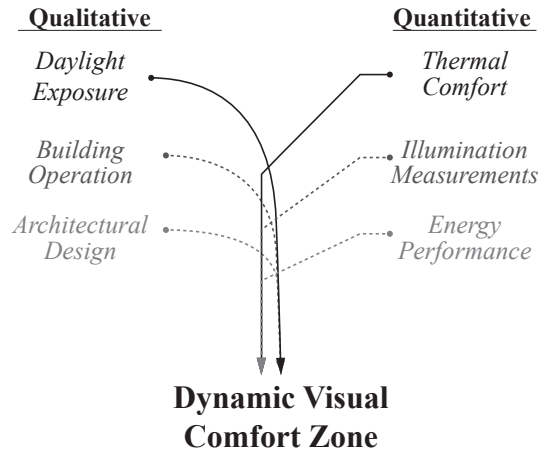

Figure 3. Extended Case Study Methodology

3.1 Occupancy Patterns

The original design intended for the building to be used as a residence, where it is assumed that occupants will spend the dominant part of the daylight hours away from the home for 5 days a week. The shift in programmatic requirements has inversed these expectations, making the daylit hours the primary time period occupation. This change in occupancy allowed for a more thorough observation of daylighting, since occupants were able to provide knowledgeable feedback about the daily fluctuations of light quality. The change in program also provided the opportunity for a closer comparison to emerging dynamic daylighting metrics, which either use a percentage of occupied daytime hours to calculate sufficient task lighting (Reinhart et al, 2012, p. 156) or considers the entire range of daylit hours for each day (Nabil et al, 2004).

Although the change in program and occupancy has provided more ideal time period, the nature of the particular occupancy at the Interlock House does not follow a traditional office occupant behavior model used in daylight design simulation programs (Reinhart et al, 2006). Occupants who use the passive house as an office arrive at 8 AM and depart at 4 PM Tuesday-Thursday, while Friday-Saturday the house is occupied from 8 AM to 6 PM.

3.2 Tasks and Activities

In addition to the shift in occupied hours, activities take place in the house that could not have been anticipated by the house designers. Animal enclosures take up a significant part of occupied space and create additional plug loads. The permanent occupants perform office tasks from 8 AM to 11 AM, which resemble office tasks described by office illumination guides but afternoons are comprised of group activities ranging from bird tagging to hikes, to cooking soup. The sunspace is fulfilling one function that was a part of the original house design, with a small garden of herbs and vegetable plants. Further discussion of the significance of specific programmatic behaviors and corresponding illuminances can be found in the Results section of this paper.

Table 1. Occupant questionnaire categories and usage.

	Content	Type of Question	Quantitative Use
Background	<i>Type of work, working time periods</i>	<i>Open ended</i>	<i>Photometric Sensor Data</i>
Anecdotal Building Performance	<i>Occupants describe specific instances they found [un]comfortable</i>	<i>Open ended</i>	<i>Daily Illumination Performance</i>
General Building Performance	<i>Comfort ratings, frequency of comfort, type of [dis]comfort, time of day assigned to comfort ratings</i>	<i>Likert Scale</i>	<i>Average Illumination Data</i>
Occupant Satisfaction	<i>Productivity and satisfaction assigned for individual spaces</i>	<i>Likert Scale</i>	<i>Average Illumination Data</i>
Social Parameters	<i>Inter/Intra occupant attitudes towards building operation</i>	<i>Open ended</i>	<i>General Use</i>
Data Reporting	<i>Occupant data reporting habits and feedback</i>	<i>Open ended</i>	<i>Irregular Hourly Data Identification</i>

5. Methodology

Methodology aims to pair quantitative performance measurements with qualitative feedback from occupants. Figure 3 illustrates the occupant-centric framework used to conduct the study. Both qualitative and quantitative data are examined at four time scales in order to draw connections between the architectural design and effective daylighting performance. A study conducted by Miller, Buys, and Bell (2012) using a similar extended case study methodology serves as a precedent for holistic building evaluation. By conducting interviews with passive solar home occupants and collecting thermal performance data, Miller, Buys, and Bell were able to identify an acceptable level of thermal comfort. This study aims to produce similar results for the performance of natural illumination, in an effort to aid in the development of natural illumination design techniques that improve comprehensive building performance.

Preliminary occupant questionnaire collections have revealed thermal comfort as the primary factor influencing occupant satisfaction. As a result, light and temperature sensors are placed throughout the house to measure building performance, while occupants are allowed to operate the passive house as they would on a typical work-day. Occupants were asked to record any adjustment to the building using an Activity Log worksheet kept in a word processing document. It is assumed that not all adjustments to the house are recorded, and datalogger readings were closely studied to identify any instances of missed activity records.

Occupant questionnaires were collected at the end of the study period for direct comparison to light and temperature measurements. Results of this pairing produced a set of ‘comfortable’ daylight readings that are then compared with dynamic daylighting metrics used by daylight design simulation programs.

5.1 Season

The first stage of this study was conducted over a two-week period during December 2013 and January 2014. This study period allowed for easy comparison to other

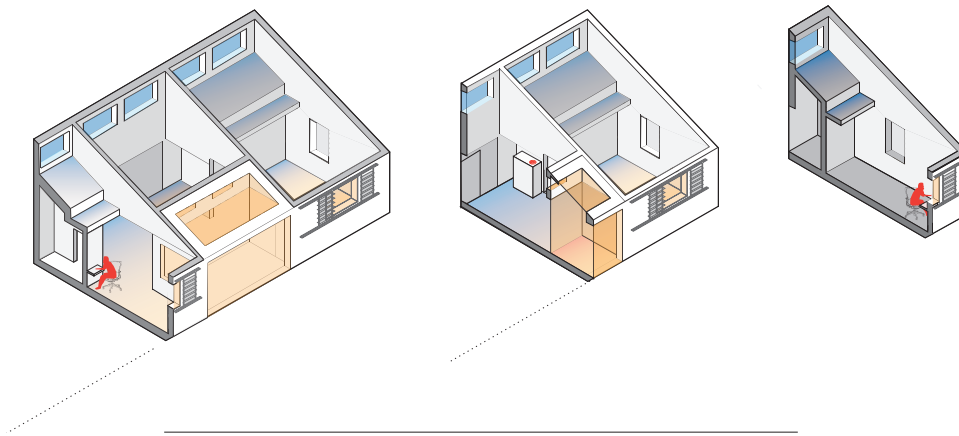

Figure 4. Work surfaces and corresponding illumination

daylighting studies using performance information for the winter solstice. The extreme climate conditions in the winter of 2013/2014 make this study especially noteworthy as a result of the extreme polar temperatures experienced. A radiant floor heat system was allowed to run by the occupants as needed due to the anticipated cold temperatures typical to the American Midwest.

The initial stage of this study was determined based on the availability of radiation data collected by on-site dataloggers. Once a methodology was established, a follow-up section of the study was executed using an additional 8 weeks of data collected at the Interlock House from a remote datalogger, without radiation data collected from on-site dataloggers. These 10 weeks of illumination data represent winter-time performances, and data will continue to contribute to the dataset until an entire year is collected.

5.2 Occupant Questionnaire

A longitudinal occupant survey was developed for long-term collection of occupant behavior patterns, expectations, and satisfaction ratings. Beginning in April 2013, the occupant questionnaire was delivered via email once every two months. The survey consists of 6 sections (Table 1) and takes about 5-10 minutes to complete. Survey content was based on the concept of comprehensive building occupation, using a questionnaire precedent by a similar study of passive solar homes by Pilkington, Roach and Perkins (Pilkington et al 2011, p. 4694). The year temperature swings specific to the Midwest and short study period led to the use of only two rounds of occupant survey responses to be used in this study. Public survey cards are currently being collected to further develop comfort ratings at the Interlock House.

5.3 Light Sensor Placement

Three photometric sensors were placed throughout the house to best represent typical activities recorded by occupant activity logs. Activity records showed a strong correlation between required task illumination and eye level height. Using the occupant questionnaire, typical hourly time blocks were assigned to various task locations, revealing that the Bedroom Desk, Kitchen Desk, and Central Hall/Living Room would be locations most representative of the daylight perceived by occupants and visitors to the house.

Kitchen and Bedroom Desk sensors were placed at desk height while the living room was measured using a sensor placed on top a piece of furniture 0.9 meters above desk height. The inverse square law was used to compensate with the height difference, although

it should be noted that these values are relative. This sensor location receives luminance from 4 northern clerestory windows as well as direct light from the sunspace, meaning that the inverse square law is not completely appropriate for accurate illumination values due to the lack of specific point location delivering illumination (Tragenza 2011, p. 39). This study will treat the photometric sensors referred to as Kitchen Desk and Bedroom Desk as accurate, while the values produced by the photometric sensor located in the living room will be referred to as Reptile Cage, and should be read as relative values. Additionally, occupant questionnaires reveal that relative to the bedroom and kitchen, the living room is only found to be 60% effective for tasks performed by the occupants of Interlock House. Further study of this location should be pursued (See Results for further discussion). All illumination measurements are extracted from a spreadsheet produced by an in-house datalogger. See Figure 4 for sensor placement.

5.4 Temperature Datalogger Sensor Placement

Temperature influenced by radiation is measured using temperature dataloggers. Two on-site dataloggers measuring temperature once per minute accompany each photometric sensor location. One datalogger is situated 1 inch above desk height inside a mylar radiation shield. The temperature difference between the protected and unprotected temperature datalogger is then calculated to gauge the amount of heat being produced by solar radiation daily throughout the test period. Temperature dataloggers are accurate within $.35^{\circ}\text{C}$ ($.63^{\circ}\text{F}$).

6. Results

Due to the quality-based comments which prompted this study, it was established early on that this investigation would be motivated by an underlying emphasis on factors that could be described as producing quality light. Quality light can be described as lighting perceived as enjoyable through distant outcomes such as context, task, and intentions for the specific lighting condition in question (Boyce, 2013). The nature of the occupant's work as naturalists is very conducive to changing illuminances, meaning that varying illumination values are not only considered acceptable, but rather ideal. Additionally, the active lifestyles of the occupants lends itself to a more flexible workspace, as well as opportunity for adjustments to architectural illumination controls. Finally, the integration between indoor and outdoor environments characteristic of passive solar designs may increase the occupant's comfort level with variable or lower illuminances. As a result of these specific conditions of design, climate, and occupancy, an illumination design was achieved that could be described as comfortable.

Representing successful illumination at the Interlock House revealed a disconnect between quantitative and qualitative data. Not only did pre-construction simulation values prove to be an insubstantial indicator of quality, but also to be disconnected from the specific contextual, occupational, and programmatic conditions at the Interlock House. Figure 9 displays further efforts to compare existing task-based metrics as well as emerging dynamic daylighting metrics with Interlock House illumination data. Illumination metrics have been suggested to create indifference towards lighting, because a single quantitative value simply serves to satisfy basic illumination requirements (Boyce, 2013). The variation in illumination data collected at the Interlock House begins to delineate a range of illuminances that could not only produce a more enjoyable space, but also add to the refinement in approach towards illumination design guided by metrics.

There is a great deal of anecdotal evidence that occupants prefer daylight in workspaces (Galasiu et al, 2006), and field studies have revealed a significant degree of adaptability held by office workers towards illumination intensity (Nicol et al, 2006). But occupants do not just tolerate the fluctuations in daylight performance, they actually rely on a perceivable

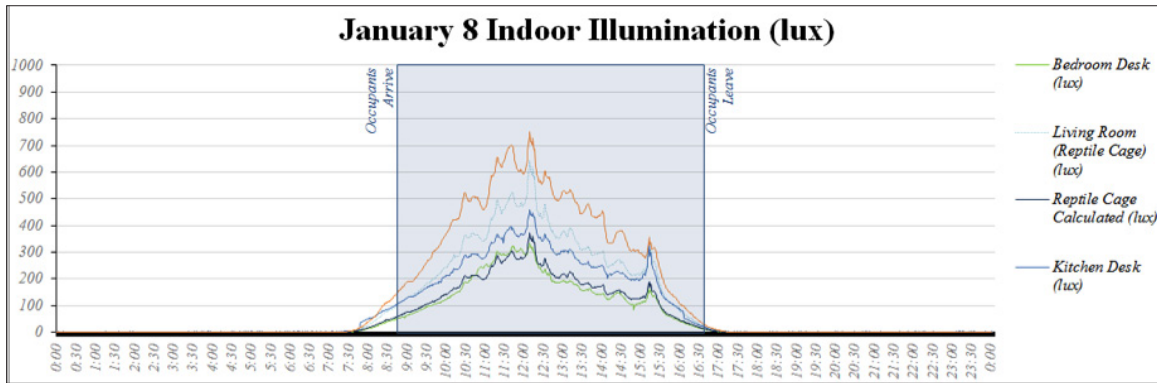

Figure 6. Relationship of indoor and outdoor illuminance without occupant impact

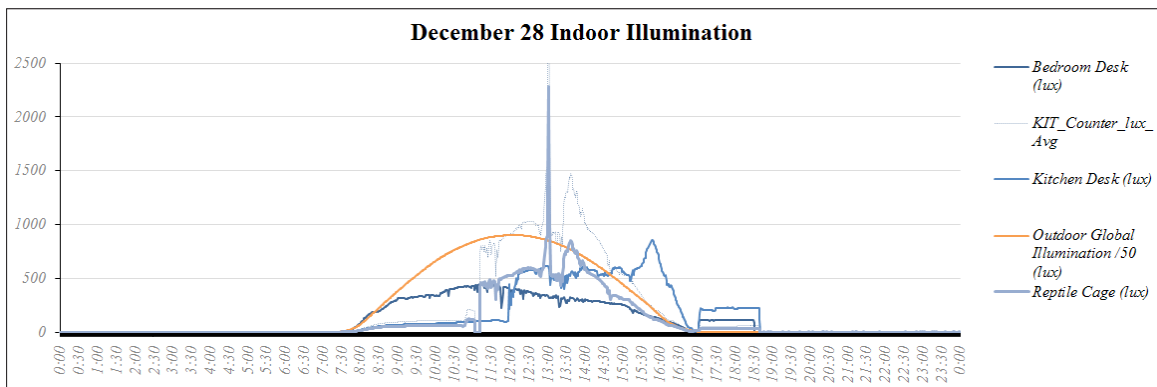

Figure 7. Evidence of personal control and building depth resulting in no need for additional illumination

level of illumination variance (Tragenza 2011, p. 5). This case study set out to identify if this preference for daylight is affected by the solar gain essential for effective passive solar performance, and concludes that through strategic architectural design specifically intended for independent daylight performance, occupants are able to achieve a ‘comfortable’ illumination level without the need for regular electrical lighting.

As a result of the dominantly independent daylight performance, recorded illumination measurements were used to place quantitative values on time periods characterized by tasks that occupants found to be comfortably illuminated. The product of this quantification process is a preliminary dynamic visual comfort zone, which is used to compare illumination performance against emerging dynamic daylight metrics. The dynamic visual comfort zone identifies both ‘comfortable high values’ as well as ‘comfortable lows’ for time periods determined from occupant work schedules (Figure 9).

Daylight Autonomy (DA)(Reinhart et al, 2006) set at 500 lux was found to be too high in relation the dynamic visual comfort zone low threshold, suggesting that Continuous Daylight Autonomy (Rogers 2006) may be more effective towards the evaluation of effective daylight design during the initial building design phases. The Useful Daylight Illuminance (UDI) (Nabil et al, 2004) low threshold of 100 lux was found to be acceptable against the preliminary dynamic visual comfort zone low threshold, while the UDI upper limit was much greater than any illumination value recorded during the test period at the Interlock House.

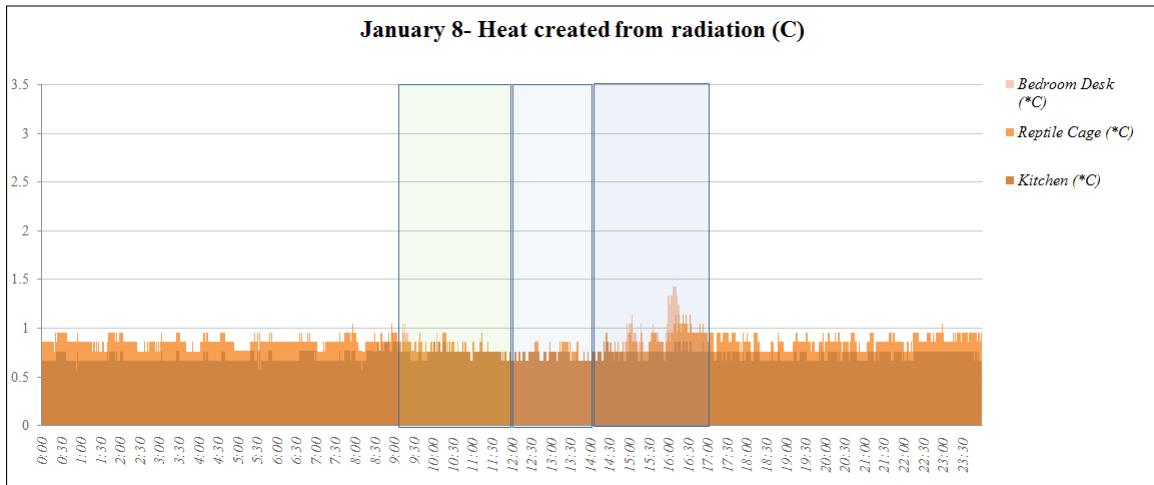

Figure 8. Heat created by solar radiation on January 8

6.1 Details of Daylight Tolerance

Self reported occupant activity logs showed minimal evidence of electrical lighting usage, meaning that little data was collected about specific instances in which the occupants found the house to be visually uncomfortable. This is considered to be an indication of a successful daylight design, as occupants do not feel an overwhelming need to revert to electrical light. Datalogger illumination measures support the sparse electrical light usage from activity logs, through the strong correlation between interior and exterior daylight fluctuations. Figure 6 shows a remarkable correlation between outdoor light and indoor daylight recorded on January 8, indicating that daylight successfully illuminated the space very minimal intervention from occupants.

Similarly, Figure 7 demonstrates the influence of sunny outdoor conditions on the indoor illumination on December 28. The bedroom desk is located roughly 2.5 meters from the south façade, and faces north against a wall. As a result, the occupant is able to work while the sunspace and clerestories light the bedroom desk. The bedroom location rarely needs any kind of illuminance intervention, which can be seen in Figure 7 through the curvature of illuminations levels, showing a strong resemblance to the exterior illumination level. Alternatively, the kitchen desk on December 28 demonstrates a need for illumination modulation without the use of electrical light. The kitchen desk currently faces the southern kitchen window, which creates a need for control of glare and privacy. Figure 7 shows the kitchen desk illumination measurements to maintain around 550 lux, as a result of shading device use, while illumination in this location still varies as light from the adjacent sunspace periodically enters the kitchen. Finally, the electrical lights are turned on from 17:00-18:30, well after sun had set, indicating that occupants truly need the light fixtures on this day only after dusk.

The illumination measurements taken on December 28 demonstrate a pattern of influence from “killer variables” (Boyce et al 2003, p. 35). These are variables that have been identified in workplaces to have significant influence on productivity (Boyce et al 2003, p. 35). The ability to individually control a space has a large impact on office worker satisfaction and productivity (Boyce et al 2003, p. 36). Use of window shades at the kitchen desk displays an adjustment of the personal control “killer” variable, through the lack of electrical lighting use. Another “killer variable” to workplace productivity is building depth created by floor plates that are too deep (Boyce et al 2003, p. 35). The bedroom desk demonstrates an ideal scenario for desk orientation working in combination with building depth. The occupant’s back faces towards the main southern daylight source, blocking direct light and potential computer screen glare. Meanwhile, northern clerestory windows and adjacent light shelves project ambient light down into the space, allowing for a reasonable and continent level of daylight to assist with office tasks.

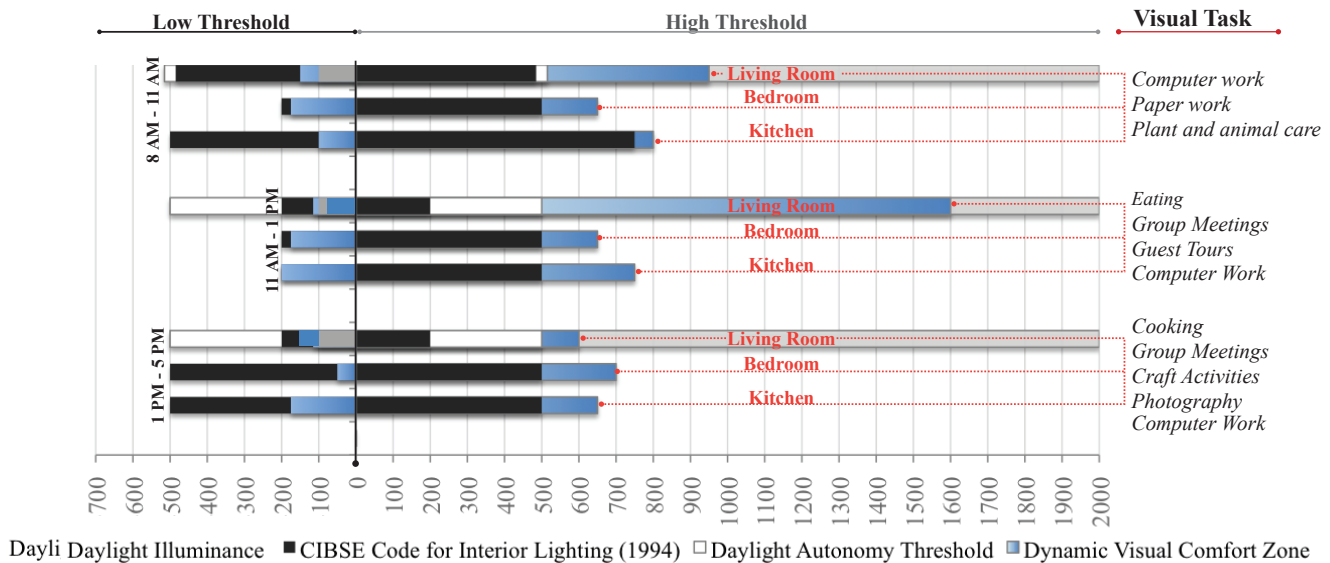

Figure 9. dynamic visual comfort zone and emerging daylighting metrics (lux).

The lack of illumination consistency for all illumination sensor locations throughout this study period displays the tolerance occupants hold for daylight fluctuations. It is clear that occupants have found strategies to work in the daylight conditions provided by the Iowa climate, and modulated by the illumination design at the Interlock House. This acceptance of illumination design and adaption using shading devices is exactly what prompted the investigation into qualitative factors influencing quantitative measures that did not measure up to the 500 lux (50 fc) prompt used for the original Solar Decathlon design competition (Leysens et al 2013, p. 5). Rather than the architectural design, the 500 lux metric was determined to be the unreliable variable causing the illumination performance to not align with pre-construction computer simulations.

6.5 Effective Architectural Design

Identifying the positive effect of the “killer variables” calls for an evaluation of architectural design strategies that produced success in daylight design at the Interlock House. The original architectural design prompt called for an 800 square foot (243 sq. m) home entirely powered by solar energy. The decision to execute this plan using passive solar technology meant the architects were able to achieve a high level energy efficiency and daylight performance that would have not been otherwise possible with an active mechanical system. The Interlock House now regularly teaches its occupants, guests, researchers, and original designers how a passive house needs an active user. In order to stay comfortable in the Midwestern United States climate, occupants must be aware of how to let the sun heat their home in the winter, and promote maximum air flow during hot, humid summers.

Walls were placed at sloping angles adjacent to windows sized for multilayered illuminance, resulting in the autonomous daylight performance currently in place today. Figure 2 shows displays how direct southern light is able to enter directly into the kitchen and bedroom, but a combination of interior and exterior shading devices provides occupants the opportunity to adjust illumination and/or solar gain. If direct southern light is found to be too great or intense, the Interlock House is able to still maintain daylit illumination while southern windows are completely covered. This is achieved through ambient northern light bounced downwards between sloped roof and light shelf planes, as well as through the sunspace, which emits large amounts of light and radiation through glazed southern and roof planes.

Table 2. Dynamic visual comfort zone relative to existing metrics

		Kitchen Desk			Bedroom Desk			Living Room (aka Reptile Cage)		
		8 - 11 AM	11 AM - 1 PM	1 - 5 PM	8 - 11 AM	11 AM - 1 PM	1 - 5 PM	8 - 11 AM	11 AM - 1 PM	1 - 5 PM
Dynamic Visual Comfort (DViC) Zone	High	800 lux	750 lux	650 lux	650 lux	650 lux	700 lux	~950 lux	~1600 lux	~600 lux
	Low	100 lux	200 lux	200 lux	175 lux	175 lux	50 lux	~150 lux	~100 lux	~150 lux
Useful Daylight Illuminance (UDI)	High	2000 lux	2000 lux	2000 lux	2000 lux	2000 lux	2000 lux	2000 lux	2000 lux	2000 lux
	Low	100 lux	100 lux	100 lux	100 lux	100 lux	100 lux	100 lux	100 lux	100 lux
CIBSE Code for Interior Lighting	High	750 lux	500 lux	N/A	N/A	500 lux	N/A	N/A	500 lux	N/A
	Low	500 lux	200 lux	500 lux	200 lux	200 lux	500 lux	500 lux	200 lux	200 lux
IESNA Lighting Handbook	High	500 lux	500 lux	500 lux	500 lux	500 lux	500 lux	500 lux	300 lux	1000 lux
	Low	100 lux	300 lux	300 lux	100 lux	300 lux	300 lux	100 lux	100 lux	100 lux

The multi-layered daylight scheme is precisely what has allowed occupants to independently control their preferred illuminance level. For example, due to spatial limitations the kitchen desk is positioned towards the southern facing window. As a result, the shades are closed at this sensor location, but Figure 7 illustrates the more constant, but still changing illuminance received at this location from the adjacent sunspace and light shelves.

6.2 Radiation Measurements

Each light sensor location was accompanied by a pair of temperature dataloggers, which together were used to measure the solar radiation of that location. Figure 8 illustrates that temperature dataloggers outside Mylar radiation shields regularly collected temperature measurements that are ~.8°C higher than those protected from radiation. Although a slight correlation between mean radiant temperature and sensible air temperature can be detected, the temperature measurement between the two dataloggers maintains the same difference throughout the entire day. Occupant questionnaire responses support the suggestion that Figure 8 displays that solar radiation does not greatly impact the interior conditions of the Interlock House at the measurement locations. But the consistency of temperature maintained at ~1.6°C indicates a stronger need for continued evaluation of the impact of solar radiation at the Interlock House.

6.3 Dynamic Visual Comfort

The necessity for active building operation in a passive solar home is exactly what has allowed for the emergence of a dynamic visual comfort zone. Occupants must collaborate with the architecture, tuning to its behavior to make themselves comfortable. While the dramatic Iowa climate has created an occupancy characterized by thermal comfort challenges, passive solar performance creates an inextricable link between thermal comfort and daylight performance. When adjusting their thermal environment, occupants modulate the daylit environment as well. The resulting daylighting records reveal a level of illumination tolerance that begins to factor in heat caused from solar gain, privacy, view,

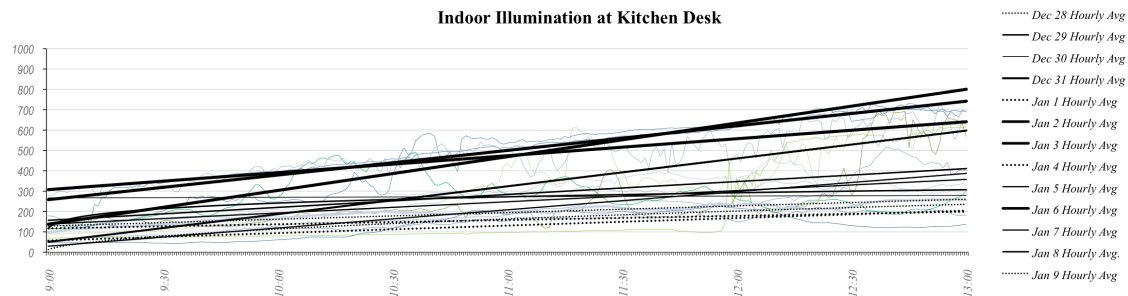

Figure 10. Variance in illumination measures and corresponding linear regression

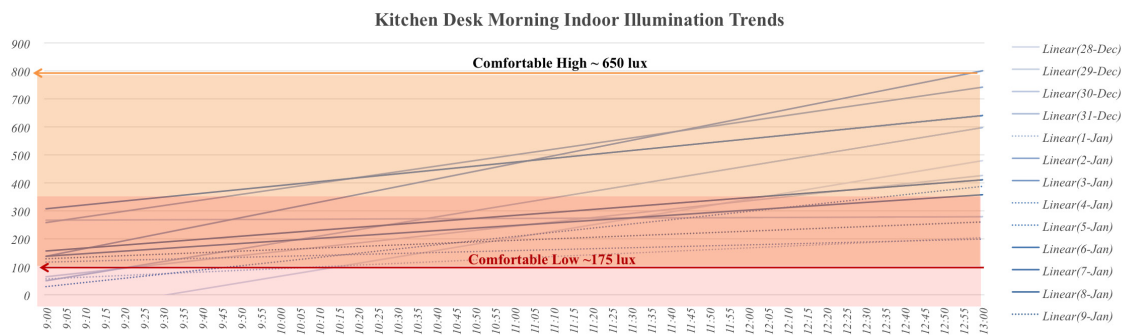

Figure 11. Identification of dynamic visual comfort zone

energy efficiency, along with many other factors that are very familiar to any house dweller, but sometimes difficult to address as an architect.

The natural fluctuations in daylight performance meant no one specific hour, day, or minute could be used as representative of typical illumination at the Interlock House. Historically, the Daylight Factor has been used to calculate a general illumination reading, but the growing prevalence and availability of simulation software has created a higher demand for reliable and accurate illumination data, to provide architects with climatically and temporally informed illumination predictions. Taking this recent priority shift in mind, it was established that in order to represent illumination performance at the Interlock House, a range of values must be identified. These values would be derived by not only the architectural design, but also the occupant preference for control and the type of task being performed. Architects are acquainted with the idea of specifying task illuminance requirements while designing interior spaces (Grondzik et al 2011, p. 681), and shading devices are also common elements in contemporary facade design. A less common practice though, is to design with consideration of the occupant's autonomous ability to adjust themselves (i.e. moving from one side of a table to another) (Jakubiec 2011, p. 167), their environment (Reinhart, 2004), or the task.

At the Interlock House, occupants must actively operate the passive solar home, meaning that they have adjusted to a lifestyle that asks for their participation in the building's ability to function. By prompting occupant's to rate their satisfaction with illumination, they are asked to respond to an illuminated environment after they have made their best effort to accommodate it to meet their needs (regardless of the environmental, financial, or social motivations for making those accommodations). As a result, the preliminary dynamic visual comfort zone is based on illuminance values that are informed by both the architecture and the occupant who operates that building.

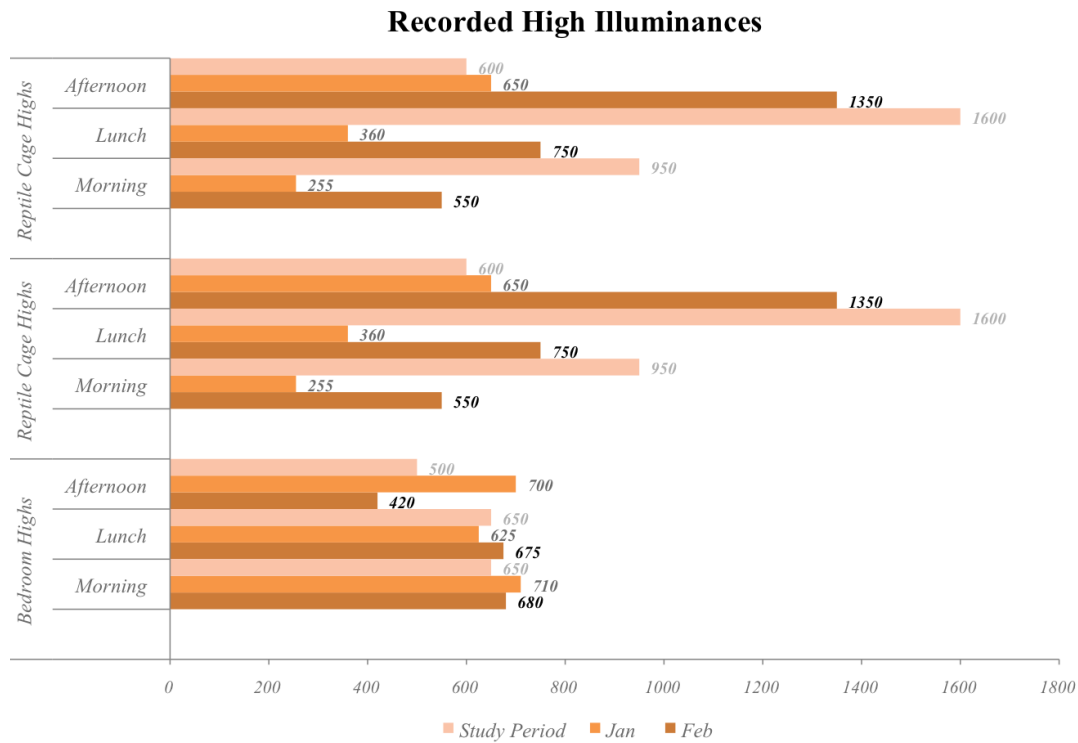

Figure 12. January, February, and Study Period high illuminance records

Considering the occupant-centricity of this preliminary metric, the occupant questionnaire feedback was used to inform the means by which the dynamic visual comfort zone was identified from the large datasets available at the Interlock house. Table 1 describes how the Occupant Questionnaire was delivered every two months, and the ‘General Building Performance’ section asked for a rating of how many days each month specific issues were found to be uncomfortable at certain times of the day. Illumination discomfort could be indicated through both glare and under-illumination questionnaire prompts. While filling out this section of the survey, it is likely occupants retroactively thought about how many days they found illumination (does not differentiate between daylight and electrical) uncomfortable. Occupants unanimously rated the illumination to be uncomfortable for ~25% of the month during this study period, meaning that upon reflecting on that month they were rating specific time instances rather than specific time periods. Additionally, this qualitative information represented a 2-week period, while the quantitative illumination measurements were only available on a minute-by-minute basis.

In order to most accurately pair these two time frames, illumination measurements for each minute were divided into daily bins for further analysis. Daily bins allowed illuminance values to be organized by daily climate conditions and occupant activity that would have affected data for each day. Climate based metrics have become increasingly prevalent in dynamic daylight simulation programs (Reinhart et al, 2006), so special attention was given to insuring the daily impact of climate on illumination data collection was retained.

The CIBSE Code for Interior Lighting recommends a range of illuminance levels which are appropriate for a series of specific tasks. This notion of task-based illuminance was used as the next step in the process of determining a dynamic visual comfort zone. Using a typical work schedule provided by occupants, daily illumination measurements were divided into 3 bins; the morning (8 AM to 11 AM), Lunch Hour (11 AM - 1 PM), and afternoon (1 PM - 5 PM). Work as a naturalist asks for a substantial range of skills and

Recorded Low Illuminances

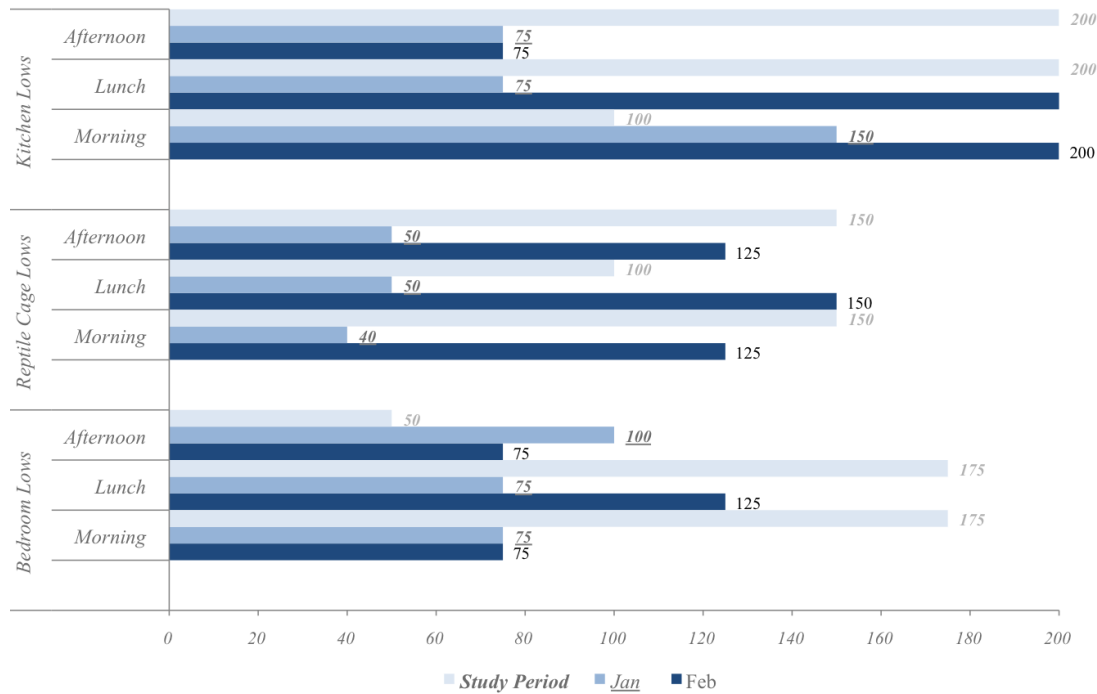

Figure 13. January, February, and Study Period low illuminance records

activities throughout the day, ranging from computer work to plant care (the right hand column of Figure 9 further describes typical tasks and time blocks), so it was necessary to divide these time periods based on illuminance needed to accomplish a range of tasks. Each time bin was then at a similar time increment to the comfort rating recorded in the occupant questionnaire. The unanimous 25% uncomfortable illumination rating was then used to remove the lowest bin of illumination data during each time period. Figure 9 further illustrates this process. After daily bins were sorted, linear regression trend lines were used to identify values that could be used as representative illumination data for that time period. Figure 10 shows the variation of illuminance data collected during each daily time bin, and the linear regression values.

7. Conclusion

It is important to acknowledge, that this illumination scenario is made possible by the passive solar nature of the case study solar home. Occupant adjustment to the architecture is informed by the need to learn strategies for balancing solar gain and natural illumination, meaning that occupant behavior is aligned with the design intentions of the passive solar home. A tolerance of fluctuating daylight is accomplished because occupants have actively worked with the house design to achieve comfortable and efficient performance. The aforementioned “killer variables” have allowed occupants to avoid radiation through shading or desk orientation, meaning that radiation does not play a large role in illumination levels perceived as comfortable by occupants. Further examination of the role of radiation at the Interlock House should be pursued, but the illumination tolerance measured in this preliminary study may suggest that Dynamic Visual Comfort Values could be applicable to buildings with active mechanical systems as well, provided that similar opportunities for occupant control and daylight availability are present.

Adjusting metrics to compensate for a lower range of tolerable illuminances presents great opportunity for improved energy efficiency and occupant satisfaction. In the United States, space heating makes up 45% of residential energy consumption, while lighting makes up 6% (US DOE, 2014). While many contemporary buildings are using strategies and emerging daylight simulation programs to lower lighting consumption, space heating can easily become compromised. Taking a passive solar design approach promotes the notion of designing for a balanced treatment of illumination and thermal comfort that could produce a more comprehensive design and energy performance. Daylight metrics provide an opportunity for introducing a multi-faceted and energy efficient approach to daylight design. This has begun to happen through the recent accomplishments in climate-based metrics, as well as a growing knowledge base of post-occupancy illumination values.

8. Appendix

This study was developed as a pilot study, used to explore a methodology designed to pair an abundance of quantitative illumination data with reliable occupant survey data. The Results section of this paper describes a preliminary set of dynamic visual comfort values supporting a satisfactory work environment performing below its intended level. The initial two-week period was established based on the availability of on-site radiation data. When radiation measurements provided inconclusive information, a follow-up stage of the study was performed using an expanded dataset. Minute-by-minute illumination values were evaluated for the months of January and February 2013 to further explore the feasibility of an occupant-based metric. While this information substantiates the dynamic visual comfort zone discussed in Section 6 of this study, statistical conclusions cannot be made at this point. Nonetheless, the Figure 12 and 13 clearly demonstrate the influence of sensor location within the house, killer variables, and monthly variations. Future research will seek to collect and interpret an entire year of illumination data, evaluating both killer variables and seasonal changes at the Interlock House, in an effort to continue identifying a dynamic visual comfort zone.

9. Acknowledgements

This material is based upon work supported by the National Science Foundation under Grant Number EPS-1101284. Any opinions, findings, and conclusions or recommendations expressed in this material are those of the author(s) and do not necessarily reflect the views of the National Science Foundation. Funding was also provided by Iowa's Department of Natural Resources and Iowa State University's Center for Building Energy Research (CBER). Mike Wassmer of Live to Zero Llc provided consultancy for the data acquisition system.

10. References

- Boyce, P. (2013) 'Lighting Quality For All', in CIBSE & SLL International Lighting Conference, Dublin
- (2009). Daylight and views - daylight [online]: U.S. Green Building Council. Available at: <http://www.usgbc.org/node/1732569?return=/credits/new-construction/v20092014>.
- Council, US. G. B. (2013). Reference Guide for Building Design and Construction. US Green Building Council.
- Energy, US. D. o. (2014). Buildings Energy Data Book [online]. Available at: <http://buildingsdatabook.eren.doe.gov/ChapterIntro2.aspx>.

- Grondzik, W. T., A.G. Kwok, B. Stein, and J. S. Reynolds (2010). *Mechanical and Electrical Equipment for Buildings*. 11th ed. Hoboken, NJ, John Wiley and Sons.
- Jakubiec, J. and C. Reinhart (2012). The 'adaptive zone' - A concept for assessing discomfort glare throughout daylight spaces. *Lighting Research and Technology* 44(2) 149-170.
- Konis, K. (2012). Evaluating daylighting effectiveness and occupant visual comfort in a side-lit open-plan office building in San Francisco, California. *Building and Environment* 59 662-677.
- Leysens I. and U. Passe (2013). *Evaluating Daylight Performance in a Passive Solar House: A Study Based on Simulation and Post-Occupancy Monitoring Results*. ASES Solar 2013. Baltimore, MA.
- Mayhoub, M. S. and D. J. Carter (2011). The costs and benefits of using daylight guidance to light office buildings. *Building and Environment* 46(3) 698-710.
- Miller, W., L. Buys and J. Bell (2012). Performance evaluation of eight contemporary passive solar homes in subtropical Australia. *Building and Environment* 56 57-68.
- Nabil, A. and J. Mardaljevic (2004). Useful daylight illuminance: a new paradigm for assessing daylight in buildings. *Lighting Research and Technology* 37(1) 41-59.
- Nicol, F., M. Wilson and C. Chiancarella (2006). Using field measurements of desktop illuminance in European offices to investigate its dependence on outdoor conditions and its effect on occupant satisfaction, and the use of lights and blinds. *Energy & Buildings* 38(7) 802-813.
- Nicol, J. F. and M. A. Humphreys (2002). Adaptive thermal comfort and sustainable thermal standards for buildings. *Energy & Buildings* 34(6) 563-572.
- Boyce, P., C. Hunter, and O. Howlett (2003). *The benefits of Daylight Through Windows*.
- Pilkington, B., R. Roach and J. Perkins (2011). Relative benefits of technology and occupant behaviour in moving towards a more energy efficient, sustainable housing paradigm. *Energy Policy* 39(9) 4962-4970.
- Reinhart, C. (2014) 'DAYSIM Header File Keyword: Daylight Autonomy', *Daylight Autonomy* [online], available: <http://daysim.ning.com/page/keyword-daylight-autonomy> [accessed
- Reinhart C, Mardaljevic J., Rogers Z (2006). Dynamic Daylight Performance Metrics for Sustainable Building Design. *LEUKOS* 3(1) 7-31.
- Reinhart, C. F. and D. A. Weissman (2011). The daylight area - Correlating architectural student assessments with current and emerging daylight availability metrics. *Building and Environment* 50 9.
- Reinhart, C. F. and J. Wienold (2011). The daylighting dashboard – A simulation-based design analysis for daylight spaces. *Building and Environment* 46(2) 386-396.
- Steg, L. and C. Vlek (2009). Encouraging pro- environmental behaviour: An integrative review and research agenda. *Journal of Environmental Psychology* 29(3) 309-317.
- Tregenza, P. (2011). *Daylighting : architecture and lighting design* / Peter Tregenza and Michael Wilson. New York: New York : Routledge.
- Zack, R. (2006). *Daylighting Metric Development Using Daylight Autonomy Calculations In the Sensor Placement Optimization Tool* Boulder, CO, Architectural Energy Corporation

WINDSOR CONFERENCE 2014

COUNTING THE COST OF COMFORT

WORKSHOP 6

Using statistics correctly to analyse comfort

Invited Chairs: Jane & Rex Galbraith with Michael Humphreys

WINDSOR CONFERENCE 2014

COUNTING THE COST OF COMFORT

THE WORKSHOP PROGRAMME

WORKSHOP 6: Using Statistics Correctly to analyse Comfort and Behaviours

Invited Chairs: Jane Galbraith, Rex Galbraith and Michael Humphreys

12th April 2014: 16.30 – 18.30 – Sandby Room (2 Hours)

This workshop will open with a general discussion on the difficulty of 'coping with' thermal comfort data and then go on to elaborate the assumptions made by taking a case study dataset from a very hot climate in the Dammam region of the Gulf. The ways in which this summer time dataset has already been analysed will be reviewed and then the three Chairs will put forward suggestions on how to improve the methodology in the spirit of building on what the authors have already done. In particular with this study assistance is being sought to get a clearer handle on the relationship between comfort, humidity and temperature in the very hot climates of the Gulf. Participants will be invited to join in the discussions with questions and alternative solutions where appropriate in a wide ranging, expert and open debate on the challenges of optimally applying statistics to the complex analysis and presentational challenges that comfort research present.

What is the relationship between humidity and comfort at high temperatures? In search of new ways of looking at the issue

Abdulrahman Alshaikh¹, Susan Roaf¹ and Robert Smith¹

1, Heriot Watt University, Edinburgh EH14 4AS

Abstract

This draft paper was developed as a stalking horse for the Windsor 2014 Conference workshop on Statistics. It presents the results of summer time field work undertaken by Abdulrahman Alsheikh in the region of Damman, Saudi Arabia and the data collected shows that middle class homes families there occasionally report thermal neutrality at very high temperatures and humidities. The issues surrounding the collection, analysis and understanding of the complex issues around the relationship between humidity and comfort at high temperatures has long been a difficult one and the paper sets out some general back ground, presents the preliminary findings from the Dammam field work and then raises some questions that we hope the expert statisticians running the workshop can help us make sense of, with a view to publishing a full paper subsequently including the results of the workshop deliberations.

Keywords: PMV, Thermal Comfort, High Temperatures, Humidity

1. Introduction

Where the temperature and humidity are both high, humidity came to be seen historically as a potent force for discomfort. Many of the early developments in heating and cooling systems that were devised to reduce humidity were instigated to improve the efficiency of manufacturing processes in hot climates and also in response to the very poor standard of building construction, particularly in cold climates. On cold damp days in buildings with thin walls that were almost the same temperature on the inside as the outside, large families gathered in wood gas or coal heated rooms resulted in damp walls and mould the health and well-being of building occupants.

John Gorrie, a pre-eminent pioneer of air-conditioning who lived and worked in Florida focussed on temperature rather than humidity in his work in his designs for cooling systems using ‘mechanical condensation’ that began as early as 1854 [i]. Many subsequent buildings were cooled with ice placed in the air supply ducts but by 1918 Alfred Woolff, Stuart Cramer and Willis Carrier, doyens of the US heating,

ventilating and air-conditioning (HVAC) industry had all built mechanical ventilation systems that incorporated humidity control to improve indoor comfort. By this stage US designers had identified humidity as a primary cause of summer discomfort and air-conditioning systems were increasingly designed not only to cool the air but to manage its humidity. Wolff concluded that 55% RH was the optimal level to strive for but such conclusions were based on little evidence. The consequence of this assumption was to push systems to use a two phase cooling systems, first chilling down the air to remove humidity by condensation and then to heat it up so further reducing its relative humidity – but only at the cost of significant energy inefficiency to get air to the required temperature.

Tradition held that cold damp weather chilled one to the bone while hot humid days made people feel sickly and uncomfortable. Today the average US worker takes one day a month off due to Sick Building Syndrome but this is a condition, that research leads us to believe, is affected by humidity but results from inadequate ventilation, chemical contaminants from indoor or outdoor sources, and/or biological contaminants.

However a key symptom of the use of air-conditioning systems is the drying of indoor air that can typically be as low as 10%-35% RH causing a range of SBS symptoms and discomfort. However it has been found that increasing humidity in such dry buildings to above 40% has no measurable impacts on occupant health [ii]. But if the core concern is occupant comfort, the subsequent century of research has often contributed to the confusion of the actual role and impact of humidity on the experience of comfort at high temperatures [iii].

A wide range of 20th Century tropical comfort indices were developed based the results of field studies and laboratory studies [iv] linking humidity to comfort in a single measure such as those developed by Webb [v], Sharma [vi] and others. In 1973 Nicol and Humphreys presented the results of field studies in the UK, India, Iraq and Singapore [vii] with result showing that mean comfort vote changes little with the mean temperature experienced^{viii}. A number of meta-analyses of the role of humidity in comfort in tropical regions have been undertaken including that by de Dear et al [ix]. Numerous recent field studies have often shown that comfort in tropical regions is experience with high humidity and temperatures when compared with Western standards for comfort [x].

In order to clarify the issues involved in our own minds we are bringing the following recent Dammam region case study to the Windsor 2014 conference for a discussion of how we might use statistics better to unravel the complex relationship between humidity and comfort at higher temperatures. Data collection and results were produced by Abdulrahman Alsheikh and the whole underlying data set was supplied to Rex and Jane Galbraith prior to the W14 Conference. They were asked to review the approach, limitations and opportunities presented by this study, during discussion at the Windsor Workshop on Statistics.

2. The Damman Case Study methodology

The Damman field surveys were undertaken using a standard longitudinal thermal sampling in air-conditioned houses in the city of Damman, Saudi Arabia. The survey involved 17 homes distributed in the eastern region of Saudi Arabia and was carried out from 10th to 31st of August 2013 during the hot season. Subjective data were collected through parallel questionnaires, which were completed during almost two weeks for each house over the day when the subjects were at home. The survey was completed with about 480 votes, the total subject group was 35 people and the gender split was eighteen to seventeen, males and females respectively. The ages of the subjects ranged from 21 to 60 years with a mean age of 34 years old. All subjects were in good health.

This study used air temperature as its principal physical variable. Air temperatures were obtained using small data loggers that collected and stored results automatically in an optional strain choice. The data loggers were fitted in two different places in each house, in the living rooms and bedrooms, and automatically measured indoor temperature and relative humidity. The positions of the data loggers were located to minimize heat from direct radiation, either from mechanical or human sources. Measurements of the environmental data were taken every five minutes and each volunteer was asked to vote at least twice a day. The survey was designed by the researcher to be operable in all smartphones platforms, making it easier, and more enjoyable, for subjects to vote during day/night time and in any situation.

The questionnaires contained four main sections and also requested personal information from subjects. The sections involved: thermal sensation, using a seven-point ASHRAE scale (cold, cool, slightly cool, neutral, slightly warm, warm, hot); metabolic rate, clothing and individual's adaptation in a specific time and occupied room. The thermal scale and other sections of the questionnaire were translated into Arabic. As the culture and religion is taken into account, Values of clothing insulation were mainly derived from Al-ajmi et al. (2008) as well as from clothing values used by Nicol et al. (2012). The metabolic rates given in ISO 7730 cited in (Nicol et al., 2012) were used in this study.

3. Results and Discussions

During the fieldwork in August the indoor air temperatures ranged from a low of 19.9°C to 35.3°C with an average of around 27°C [Figure 1]. A single high report of 39.3°C was recorded in a unique event of one of the cases.

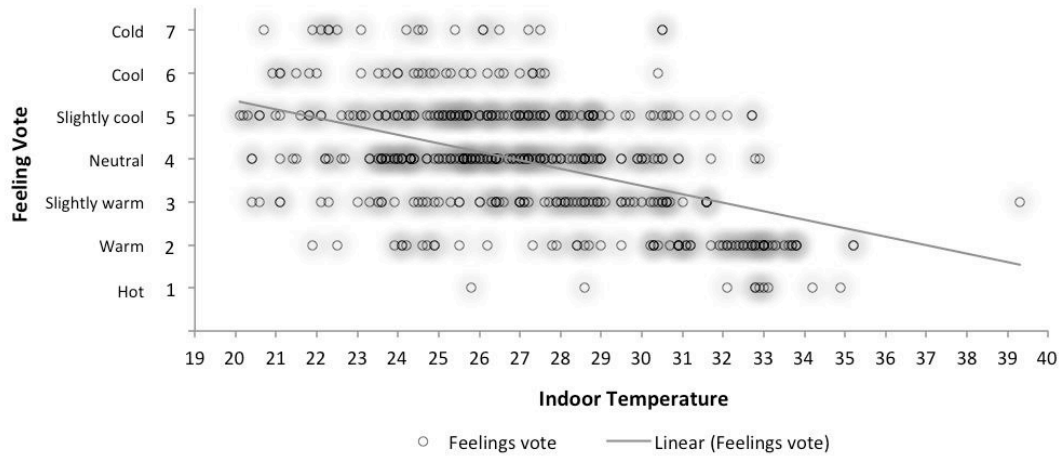

Figure 1: Distribution of indoor temperature from longitudinal survey in Dammam Region during Summer 2013.

The recorded humidity fluctuated from a low of 29% to a high of 84% with an average of around 60% relative humidity [Figure 2]. The mean clothing values were 0.42*clo* with minimum of 0.05*clo* and maximum of 0.97*clo*. About 60% of subject’s clothing values were in the scope of 0.05*clo* and 0.41*clo*. The mean metabolic rate was 0.67*met* during the hot season.

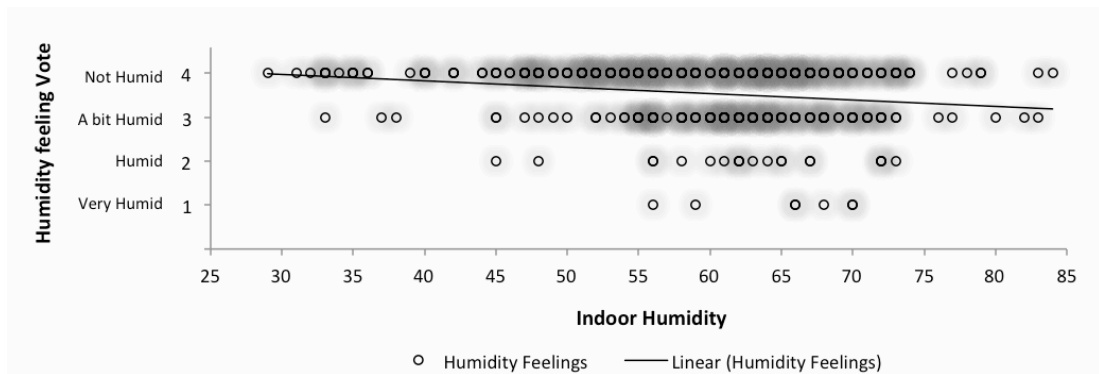

Figure 2: Distribution of indoor relative humidity from longitudinal survey in Dammam Region during Summer 2013

The analysis of the sensation votes show that about 65% of subject votes in indoor conditions indicate one of the four top categories, between Hot and Neutral, and the mean sensation votes for all subjects on the ASHRAE scale were 3.32 (Slightly warm). Furthermore, almost the same portion of subject’s votes indicated they wanted more cooling to be more comfortable which shows that people are not very satisfied with their environment conditions [Figure 3].

It is obvious to ask why, if these people did not feel comfortable, don't turn on or up the AC to be more comfortable. One question in the survey been asked of all subjects that in comparison to the monthly income, do you think that the electricity

bill is expensive? About 65% of the subjects responses were the price is expensive compared to their incomes.

In exploring the subject’s preferences data in [Figure 3] the data shows that it is fairly robust. However, the next step will be to investigate what are the boundary conditions around these outliers votes. There were in certain circumstances some votes in warm conditions asking to be a bit warmer. A preliminary analysis shows that people who prefer to be in warmer conditions, even in the range of 29-35°C, quite feel cool and are less active. Also a couple of subjects were underweight. Subjects aged between 15-20 years old voted at these temperatures for warmer conditions.

Other outlier votes showed that people in a pretty cool conditions desire to be in cooler state. Data showed that this cohort were all in the bedroom and about 90% of them were overweight. Moreover, one specific house showed a substantial portion of these outliers, so more investigation in this case is needed. In this specific outlier home it appears that those who voted to be ‘a bit’ or ‘much’ cooler, occupied indoor humidity levels above 55% and below 80%. Thus, further statistical analysis is required to understand the relationship between humidity and temperature and comfort in these studies.

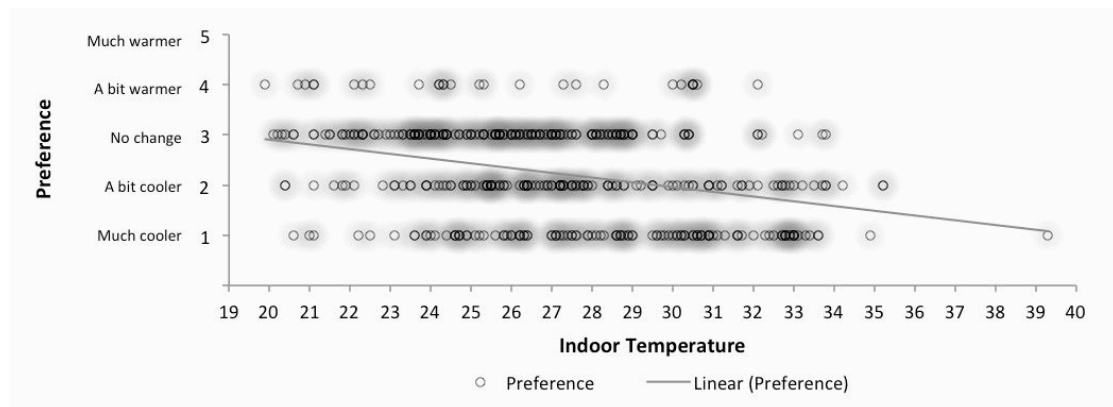

Figure 3: Regression of indoor temperature on people preferences

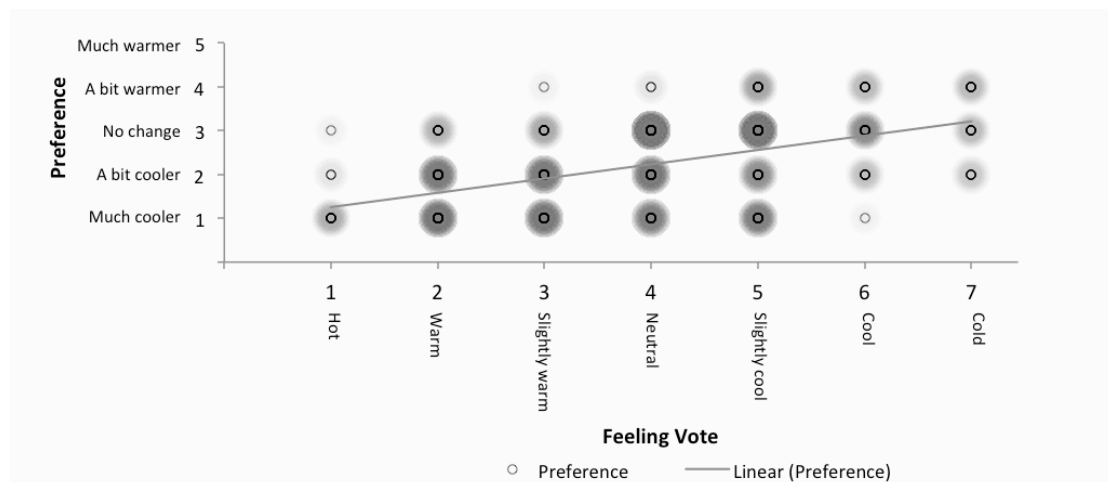

Figure 4: Regression of subject’s sensation votes on their preferences

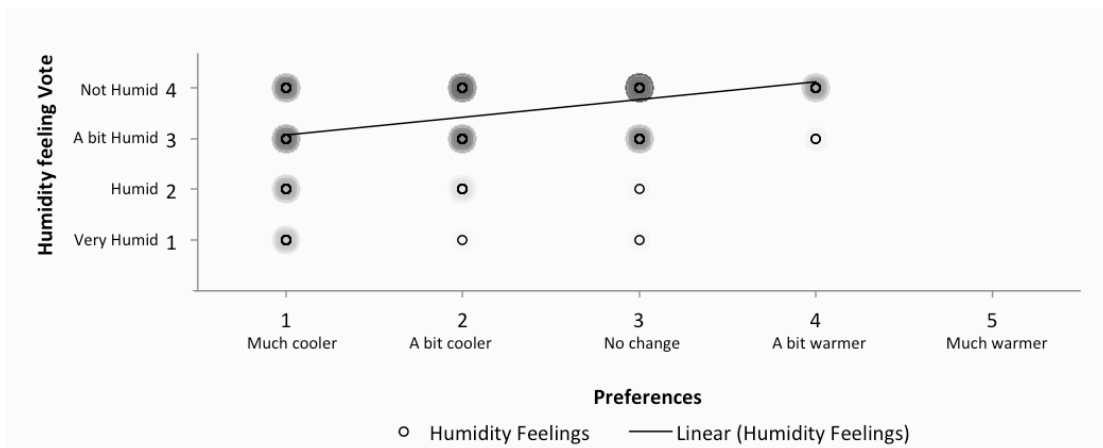

Figure 5: Regression of the subject’s humidity feeling votes on their preferences

A number of questions are raised about the ability of a standard longitudinal study of comfort in extreme conditions where multiple adaptive strategies are employed to ensure occupants remain comfortable over the day. These include:

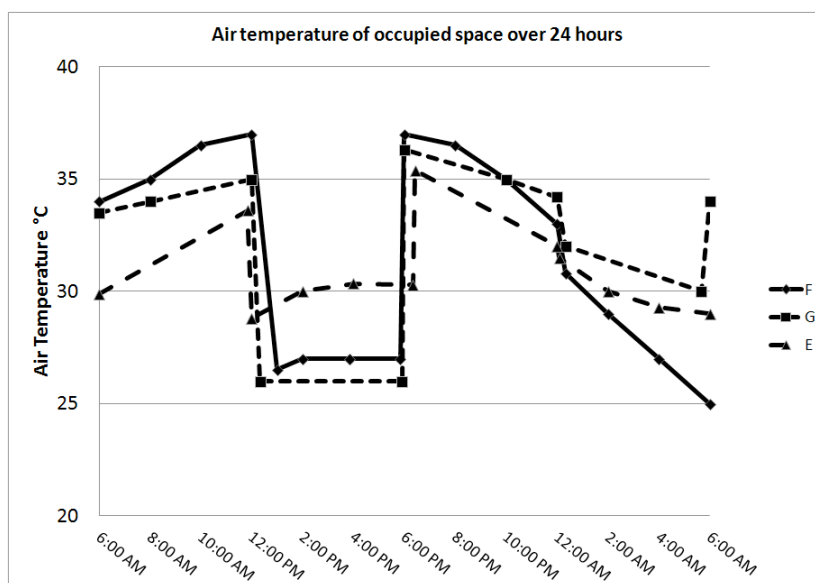

Figure 6: Temperatures occupied by housewives in the houses in the hot dry desert city of Yazd in Iran showing the wide range of thermal environments occupied over a single typical day (S.Roaf 1989[xi]).

How best can we deal with the outlier data points when they show people being comfortable at extremely high temperatures? Lifestyle observations and person centred thermal records are necessary to understand the adaptive behaviours that are used to mitigate the impacts of high temperatures experienced at different times of the day and year with building occupants:

- a) getting on with their usual lifestyles as ambient temperatures ramp up or down over a day, until a certain temperature level is reached at which point they occupants change their clothing, activities, location, turn on/off a machine or open/close a window. This ramping effect and the transition temperatures (and humidities ?) are recorded by observation, not analysis of data sets.
- b) moving from one location people can go from one state – eg. cool in a basement in Yazd (Figure 6) into a hot environment, cruising physiologically on stored coolth for a subliminally calculated safe period of time. This scavenging and storing of heat or cold, to enable people to occupy uncomfortable and/or unsafe thermal environments for intermittent periods within the well-trodden thermal pathway of a habitual lifestyle in extreme climates is common practice. The diverse thermal environments habitually occupied over a day, or over more extended periods, are not typically collected in longitudinal field studies but are key to understanding how comfort is thus achieved.

In trying to understand the complex interaction between humidity and comfort at high temperatures we are looking for help in the Statistics Workshop in exploring how we can systematise the recording of data to enable us to understand and compare the different behaviours associated with achieving comfort in such conditions and also in analysing the data in such a way that we can extrapolate from that data the key characteristics of the relationship between humidity and comfort at high temperatures.

4) Conclusions

We very much welcome the opportunity to share this data with the experts at Windsor to learn from the discussions more about this complex and yet extremely important issue.

References

-
- [i] Cooper, G. (1998). *Air-conditioning America*, The John Hopkins University Press, Baltimore.
 - [ii] Nordström, K., D Norbäck, and R Akselsson (1994). *Effect of air humidification on the sick building syndrome and perceived indoor air quality in hospitals: a four month longitudinal study*, Occupational and Environmental Medicine. 1994 October; 51(10): 683–688.
 - [iii] The subject of humidity and comfort is dealt with in more detail in Humphreys, M., F.Nicol and S. Roaf (2014), Adaptive Thermal Comfort, Vol. 2, Taylor and Francis, in Press.
 - [iv] McArdle, B., W. Dunham, H.E. Holling, W.S. Ladell, J.W. Scott, M.L. Thompson and J.S. Weiner (1947). The prediction of the physiological effects of warm and hot environments, Ref. No. R.N.P.47/391. Medical Research Council, London.

-
- [v] Webb C.G. (1959). An analysis of some observations of thermal comfort in an equatorial climate: *British Journal of Industrial medicine*, vol 16, no. 3, pp. 297-310.
- [vi] Sharma M.R., Ali S. 1986. Tropical Summer Index - a study of thermal comfort in Indian subjects. *Building and Environment*, Vol 21(1), pp 11-24.
- [vii] Nicol J.F. 1973. An analysis of some observations of thermal comfort in Roorkee, India and Baghdad, Iraq: *Annals of Human Biology Vol.1(4)* pp 411-426
- [viii] Nicol, J.F. and Humphreys, M.A. (1973) Thermal comfort as part of a self-regulating system. *Building Research and Practice (J. CIB) 6(3)*, pp 174-179
- [ix] deDear, R.J., K.G. Leow, and S.C. Foo, S.C. (1991). Thermal comfort in the humid tropics: field studies in air conditioned and naturally ventilated buildings in Singapore, *Int. J. Biometeorology 34* pp259-265
- [x] Busch J. 1992. A tale of two populations: thermal comfort in air-conditioned and naturally ventilated offices in Thailand: *Energy and Buildings Vol. 18* 235-249
- [xi] Roaf S C, 1989 *The Windcatchers of Yazd*, PhD thesis, Oxford Brookes University

WINDSOR CONFERENCE 2014

COUNTING THE COST OF COMFORT

WORKSHOP 7

Instrumentation and climate chambers

Invited Chairs: Andreas Wagner and Marcel Schweiker

WINDSOR CONFERENCE 2014

COUNTING THE COST OF COMFORT

THE WORKSHOP PROGRAMME

WORKSHOP 7: Instrumentation and Climate Chamber Design

Invited Chairs: Andreas Wagner and Marcel Schweiker

12th April 2014: 16.30 – 17.30 – Greening Room (1 Hour)

This workshop deals primarily with questions regarding the experimental design, sensor equipment and questionnaires for assessing adaptive comfort and interactions of occupants with their environment for semi-controlled climate chambers. This discussion will be going alongside with issues of the design and implementation of semi-controlled climate chambers with reference to projects where not only closed Laboratory studies are undertaken but also research on mixed mode environments such as those with opening windows and ceiling fans. New methods of evaluating sensation, perception and acceptance are being experimented with in various international laboratories. Finally, this workshop aims to start a discussion beyond classical comfort studies towards the validity of the assessment of the complex relationship between occupants thermal satisfaction and behaviour within such climate chambers.

Presenting LOBSTER, an innovative climate chamber, and the analysis of the effect of a ceiling fan on the thermal sensation and performance under summer conditions in an office-like setting

Marcel Schweiker^{1*}, Sabine Brasche², Maren Hawighorst¹, Wolfgang Bischof² and Andreas Wagner¹

1 Karlsruhe Institute of Technology, Building Science Group, Englerstr. 7, 76131 Karlsruhe, Germany, marcel.schweiker@kit.edu

2 University Hospital Jena, Institute of Occupational, Social, Environmental Medicine and Hygiene, Department of Indoor Climatology, Bachstr. 18, 07743 Jena, Germany

Abstract

Thermal comfort studies have been performed so far either in closed climate chambers with controlled conditions or non-controlled conditions during field studies. Detailed analyses of mechanisms behind the adaptive comfort models are therefore hardly possible. This paper presents a newly constructed climate chamber in Karlsruhe (Germany) along with the complete chain from subjective experiments, via data analyses, model development and implementation into dynamic building energy simulation until the formation of a decision base for or against a renovation measure for a confined case. The objective of this experimental series conducted in summer 2013 was the analysis of the effect of a ceiling fan on the perceived thermal comfort and performance. The results suggest that it is not the control itself, which leads to a higher acceptance of increased indoor temperatures in summer, but the effectiveness of the control. For the analysis of the performance tests, only minor differences in the performance under the distinctive conditions were observed.

Keywords: Adaptive comfort, fan usage, occupant behaviour, neutral temperature, simulation

1 Introduction

The foundations of thermal comfort studies have been laid in closed climate chambers (Fanger, 1972). Today these studies are criticised for the lack of adaptive opportunities subjects had during the experiments. At the same time, the studies conducted within the development of the adaptive comfort model are field studies missing controlled conditions (deDear et al., 1997, Humphreys and Nicol, 1998). Detailed analyses of individual portions of the adaptive mechanisms are therefore hardly possible on the existing dataset.

This paper presents a newly constructed climate chamber in Karlsruhe (Germany) along with the results of a first experimental series conducted during the summer 2013. These results are implemented into a dynamic building simulation in order to form a decision base for renovation measures.

The objective of the first experimental series was the analysis of the effect of a ceiling fan on the perceived thermal comfort and mental performance. The ceiling fan was

chosen because it is - compared to others - a rather cheap investment which could be applied easily during remodelling projects.

The hypotheses tested were related to differences in the thermal sensation, acceptance and preference votes as well as the results of the performance tests between three conditions. Their distinction was based on the degree of permitted ceiling fan usage.

2 LOBSTER – an adaptive test facility

The Laboratory for Occupant Behaviour, Satisfaction, Thermal comfort and Environmental Research (LOBSTER) was designed for studies on adaptive comfort and occupant behaviour.

In order to facilitate studies on adaptive comfort, the two identical fully equipped office rooms have one façade to the outdoor environment (see Fig. 1). Each office room has integrated in the post and beam structure made of insulated aluminium profiles two windows and two top light windows. The windows can be opened and tilted; the top light windows can only be tilted (see Fig. 2). The glazing is a triple glazing; the opaque balustrade is equipped with vacuum insulation panels. The windows are tilted mechanically either by pressing a button on the window catch or through the building control system. Opening the windows has to be done by hand.

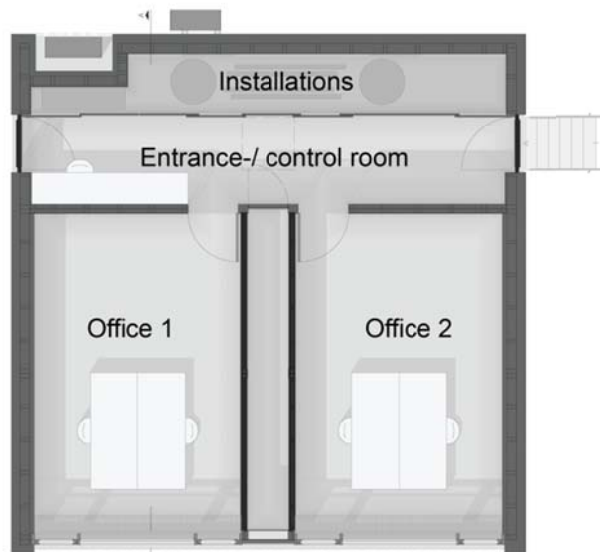

Figure 1. Floor plan



Figure 2. One of the office rooms

In addition to the possibility to open one or both of the windows, the ventilation concept involves two decentralized floor convectors able to heat or cool the inlet air before entering the office space and a fan driven exhaust system in the back of the room.

The whole of the glass surface can be shaded by electrically driven Venetian blinds with daylight guidance from ROMA (see Fig. 3). The daylight guidance provides daylight through the upper part even when the lower part of the blinds is completely closed.

With respect to studies on occupant behaviour, subjects can be granted – depending on the experimental setup - multiple adaptive opportunities such as controlling the

window opening, the Venetian blinds or a ceiling fan (see Figs. 2 and 3). On the other hand, all those interactions – except a full opening of the windows – can be done by the researcher or an algorithm through the building control system accessible for the researcher through LabView.

Five of six surfaces (all except the post and beam façade) are activated with a capillary tube system, which allows changing the set point temperature of each wall surface individually. In the framework of these experiments the control of the surface temperatures was not in the hands of the subjects – in fact, they were not told that such panel exists.



Figure 3. Venetian blinds with daylight guidance

3 Experimental design

The experimental design presented by Schweiker et al. (2012) was adapted to suit the current objectives. With the focus on the effect of a ceiling fan, only three conditions were chosen: i-, i+, and iP.

During the i- conditions, the subjects were allowed to control the window opening, sun protection state and lighting level. During the i+ settings, they were able to control the ceiling fan state in addition to the controls of the i- setting. The usage of the ceiling fan was also allowed during the iP conditions. Thus, the ceiling fan was set on reverse mode, so that its effect on changing the air velocity at the work space was reduced to a minimum.

In addition, the set point temperatures of the wall surfaces and the air supply were controlled non-steady-state. They stayed at 1K below the adaptive comfort temperature calculated according to DIN EN 15251 between 9am and 9:30am. From 9:30am until 4:30pm their set point temperature was increased linearly from 1K below the adaptive comfort temperature until 3K above it, i.e. at the end of the day, they were 1K above the comfort band according to category I (see Fig. 4). Under the postulate of the adaptive comfort model, one can expect that the thermal strain is comparable from day to day despite changes in the outdoor weather conditions.

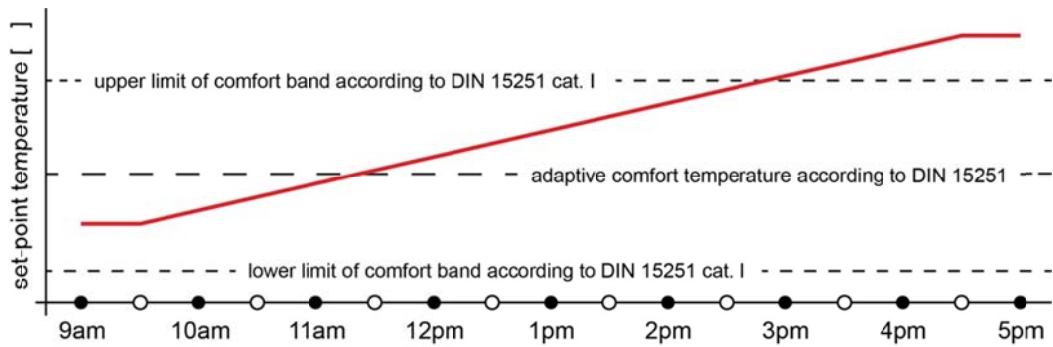

Figure 4. Temperature profile of wall surfaces and the air supply system

Table 1. Average and standard deviation of subjects' gender, age, height and weight

	N	Age [a]	Height [cm]	Weight [kg]
Female	10	25 (sd=4.6)	170 (sd=6.0)	63 (sd=7.0)
Male	11	25 (sd=4.0)	187 (sd=5.8)	83 (sd=10.8)
All	21	25 (sd=4.2)	179 (sd=10.6)	73 (sd=13.7)

In total 21 subjects (11 male, 10 female) were chosen as subjects based on their health conditions. Table 1 summarizes their basic characteristics.

The subjects were asked to work on their own during 3 consecutive days for 8 hrs (from 9 am till around 5 pm with 30 min lunch break) in the test facility. Each of the three distinctive sessions introduced above had to be conducted once. The order of conditions was randomized, i.e. around one third of the subjects started with i- sessions, the next third with i+ sessions and the last group with iP sessions.

Every morning, the subjects were told, whether they could use the ceiling fan or not. The mode of the fan (reverse or not) was not communicated. The ceiling fan was controlled by the subjects via a web-based interface, which was unlocked during i+ and iP-sessions.

During the day, subjects had to fill out a computer-based 5-minute comfort questionnaire with 30 items roughly every 90 minutes (see Fig. 5). The questionnaire was used to assess the thermal sensation vote (ASHRAE 7-scale), thermal preference (4-scale), thermal acceptance (4-scale), perceived air movement, preferred air movement as well as three items related to the perceived levels of pleasure, arousal and dominance (Lang et al., 1993).

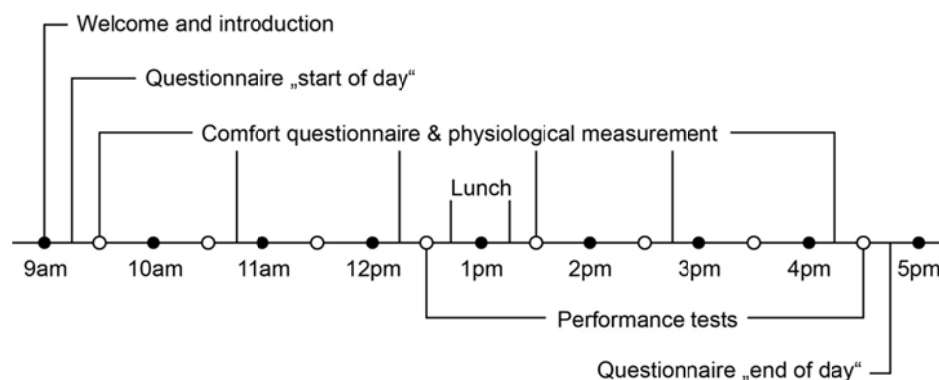

Figure 5. Timeline of surveys and physiological measurements

Twice a day (before lunch and before the end of the experiment), they had to do three performance tests in a row: the Tsai-Partington, addition and the d2 taking in total 15 minutes.

For the Tsai-Partington, subjects were given two sheets of papers with 25 randomly distributed numbers from 1 to 99. They had to link the numbers in ascending order within 40 seconds for each sheet (Ammons, 1955). The addition task took 5 minutes within which the subjects had to solve as many additions of 5 two-digit numbers as possible (Wargocki et al., 1999). The d2 is a test for the assessment of selective attention and concentration (Brickenkamp, 2002).

In addition, physical parameters of the indoor and outdoor environment such as air temperature, surface temperatures, humidity, and air velocity were measured continuously in a one minute interval.

3 Hypotheses

The hypothesis regarding the thermal comfort votes obtained in each session are shown for the thermal sensation vote in Figure 6. Due to the higher degree of control together with an increased air velocity, the thermal comfort votes obtained in condition i+ are suspected to be higher, i.e. closer to neutral, compared to the i- sessions. For those obtained during the iP sessions two outcomes are possible according to the literature. They could be higher due to the higher degree of control or lower due to a non-efficient control and corresponding dissatisfaction.

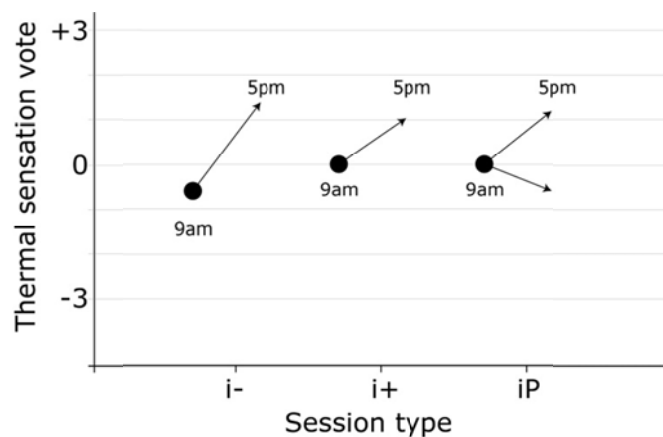

Figure 6. Hypotheses related to session type and thermal comfort votes.

4 Analysis methods

4.1 Data preparation

Besides data maintenance, the following items were derived from one or more directly observed values:

- The operative temperature was derived based on air temperature, globe temperature and air velocity measured adjacent to the workplaces close the middle of the room.
- The neutral temperature by Griffith' method, T_{nG} , was calculated for each vote according to the modifications described by Rijal et al. (2008), which gives the neutral temperature to be

$$T_{nG} = T_g + (0 - TSV) / R, \quad (1)$$

with T_g being the globe temperature and R a factor representing the expected change in TSV for each degree rise in the globe temperature. T_g is used as an approximation to operative temperature in their study, so that T_o could be used for this study without problems. R was set to be 0.33, which is related to the findings of Fanger (1972) that, all else being equal, the comfort vote increases by one unit for each three degree rise in globe temperature.

- For the addition task, the speed was calculated according to the number of correct answers per second.
- For the Tsai-Partington-test, the total number of correct links was calculated for both sheets, representing the total number of correct links within 80 seconds.
- For the d2 test, the concentration performance was calculated according to Brickenkamp (2002).

4.2 Statistical analysis

In order to reveal differences between the sessions in thermal comfort votes and performance the Wilcoxon signed rank test for related samples (Wilcoxon, 1945) was evaluated using the statistical software SPSS. As input to the test, a) the means of all measurements for each session type (experimental day) were calculated for each subject and b) the means of the last two measurements of each session type (day) were taken.

The usage of the ceiling fan was recorded in percentage of the maximum speed. For the model development, these values were recoded to show “0” when the fan was switched of and “1” in the other case. Such dichotomous data can be used to derive a logistic regression model of the form

$$p_{\text{Ceiling fan}} = \frac{1}{1 + \alpha e^{-(\beta \theta_{Op})}} \quad , \quad (2)$$

with $p_{\text{Ceiling fan}}$ being the probability that one can observe the ceiling fan being switched on, α and β the coefficients derived and θ_{Op} the operative temperature.

4.3 Implementation into dynamic building simulation

The logistic regression model of ceiling fan usage for the i+ session was then implemented into a dynamic building simulation. First, an idf (EnergyPlus) model of a simple 4m width and 6m deep office cell with the South facing wall adjacent to the outdoors was created using DesignBuilder. The South façade has a wall-to-window ratio of 50%. The walls have a U-value of 1.5 W/(m² K), the window a U-value of 1.72 W/(m² K) and a g-value of .69 representing an existing not refurbished building standard from before 1978 in Germany. The building was situated in Freiburg/Germany. There was neither cooling nor a sun shading device implemented. Schedules and activity levels were chosen to be typical for an office.

The idf model was then coupled via MLE+ (Nghiem, 2014) with a MatLab-model containing the code for the probabilistic ceiling fan usage model. Though, EnergyPlus does not offer a ceiling fan, for each timestep, the prevailing operative temperature was passed from EnergyPlus to MatLab. Within MatLab the probability of the ceiling fan was calculated according to the logistic regression model and compared to a random number. In case the random number was higher than the probability, the ceiling fan was considered to be switched on. At the end of each of the 100 simulation

runs, the number of timesteps the ceiling fan was switched on was summed up and multiplied by 100W, which was considered to be a medium power.

In addition, the number of hours being outside the comfort range was derived. The comfort range was defined as 2K above the median neutral temperature observed during i- and i+ sessions.

5 Results

Figure 7 presents the mean difference together with the standard deviation between operative temperature and adaptive comfort temperature for each session type at the times of the comfort votes. In addition the set point according to the experimental design is shown. While i- sessions tend to be cooler at the end of the day than scheduled, i+ and iP sessions are in the middle of the day up to 2K higher than set.

The latter is due to the simple control algorithm implemented during this first series of measurements. Due to time constraints in the preparation phase the control did not react to increased thermal loads either solar or due to any occupancy.

In Figure 8, set point, measured surface, air and derived operative temperatures are shown alongside with the behavioural variables for the window, ceiling fan and sun protection states. The temperatures show that real conditions were warmer than they were meant to be as explained above.

The total number of votes in total and for each session type is shown in the first column of Table 2. With all 21 subjects giving all votes, a total of 126 votes per session were expected. The missing votes happened due to subjects having been to the restrooms short before a scheduled vote, or having been absent due to important meetings, which could not have been avoided.

The mean values and standard deviations of running mean outdoor temperature, T_{rm} , operative temperature, T_{op} , relative humidity, RH, and air velocity, v , are presented in the following columns of Table 2. The mean T_{rm} 's are very similar, while T_{op} and v differ. The latter was expected due to the difference of ceiling fan usage, while the former was due to different interactions of subjects with their controls.

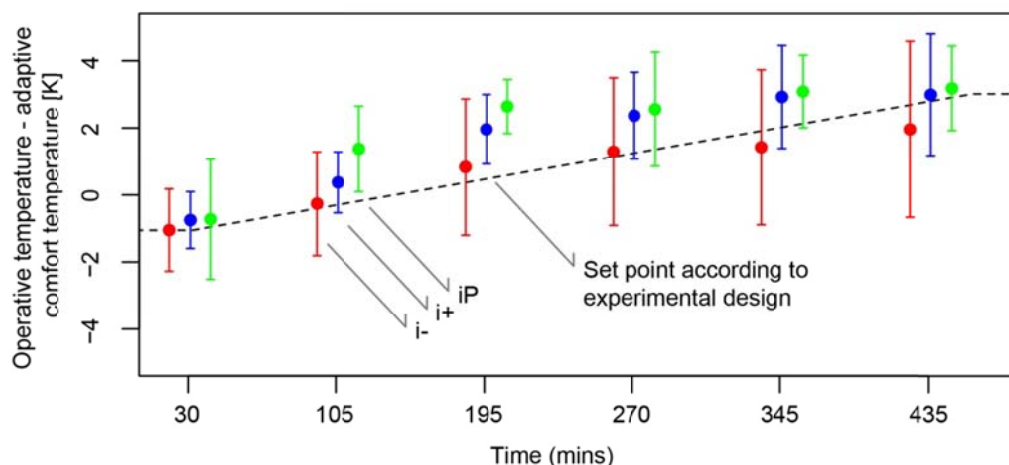

Figure 7. Mean and standard deviation of the difference between operative temperature and the adaptive comfort temperature for each session type and interval of comfort vote. The dashed line shows the set point according to the experimental design.

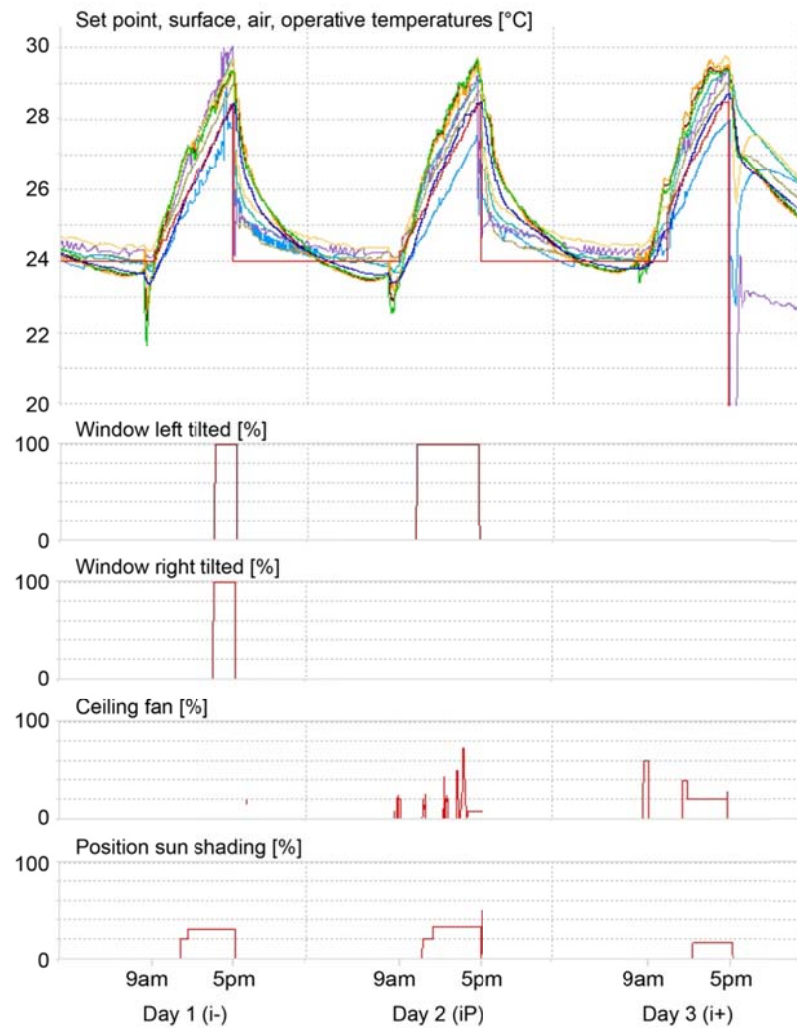

Fig. 8. Example of temperature values and behavioural data for one set of experiments, i.e. three experimental days (in this case the first day was the i- session). The red line in the top element shows the set point temperature for the surfaces; the operative temperature is drawn in purple, the air temperature in green and the other colours represent the five surface temperatures.

Table 2. Number of votes, mean values and standard deviations of thermal sensation vote, TSV, running mean outdoor temperature, T_{rm} , operative temperature, T_{op} , relative humidity, RH, and air velocity, v , for the full data set and each condition

Data (subset)	N	TSV	T_{rm} [°C]	T_{op} [°C]	RH [%]	v [m/s]
all	356	4.4 (0.9)	19.3 (1.5)	26.7 (2.3)	45 (7)	0.17 (0.15)
i-	119	4.4 (1.0)	19.1 (1.5)	25.8 (2.4)	48 (7)	0.11 (0.05)
i+	120	4.2 (0.7)	19.5 (1.4)	26.9 (2.1)	45 (7)	0.27 (0.21)
iP	117	4.6 (1.0)	19.3 (1.5)	27.2 (2.1)	42 (6)	0.14 (0.11)

5.1 Comparison of thermal comfort votes and performance between sessions

Figure 9 shows the mean and standard deviation of thermal sensation votes according to each session type at each survey period. The tendencies vary during the morning (first three votes): the votes obtained during i+ sessions are the lowest, i.e. subjects stating to sense the most comfortable, followed by those from the i- sessions and the iP sessions. The afternoon votes show that the i+ sessions are sensed in average as being most comfortable, followed by the iP and the i- sessions.

The results of the Wilcoxon Signed Rank tests for the daily mean thermal comfort votes and the mean of the calculated PMV for the six measurements are shown in Table 3. For all items except PMV, the Wilcoxon signed-rank test showed a statistically significant change between i- and iP-sessions. In addition, thermal sensation votes differed statistically significant between i+ and iP sessions and neutral temperatures between i- and i+ sessions.

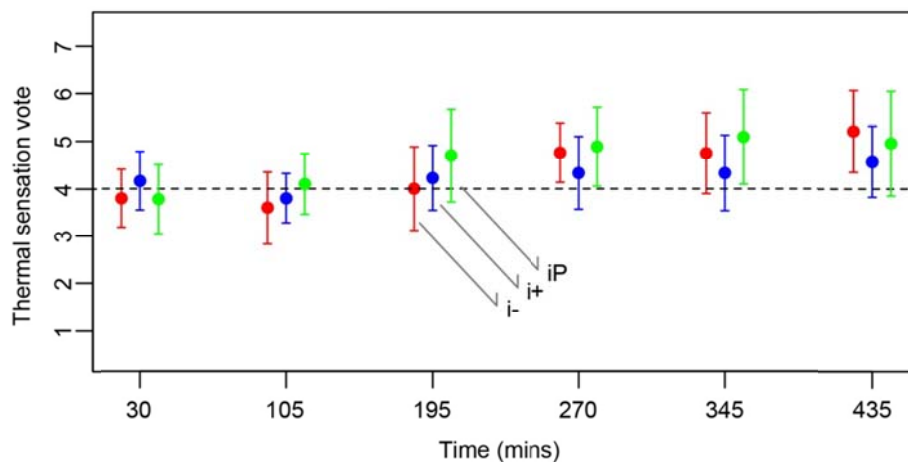

Figure 9. Mean and standard deviation of thermal sensation votes grouped according to session type and binned for each survey period

Table 3. Median, Z- and p-value of Wilcoxon signed rank tests for four items related to thermal comfort. Significant differences ($p < 0.05$) are marked with bold characters.

	Median			Result Wilcoxon signed rank test		
	i-	i+	iP	i- to i+	i+ to iP	i- to iP
Thermal sensation vote	4.33	4.17	4.67	-.93 (.353)	-2.77 (.006)	-2.06 (.039)
Thermal preference	-.33	-.17	-.50	-.992 (.321)	-.766 (.444)	-2.20 (.028)
Thermal acceptance	-.50	-.33	-.67	-1.33 (.183)	-.987 (.324)	-2.74 (.006)
Neutral temperature	25.1	26.6	25.9	-2.73 (.006)	-1.30 (.192)	-2.42 (.016)
PMV	.42	.35	.39	-.40 (.689)	-1.65 (.099)	-1.58 (.114)

The results of the Wilcoxon Signed Rank tests for the mean of the last two thermal comfort votes and calculated PMV of each day are shown in Table 4. For all items, the Wilcoxon signed-rank test showed a statistically significant change between i+ and iP-sessions. In addition, neutral temperatures show statistically significant differences between all sessions. There is no statistically significant difference between i- and i+ or i- and iP sessions for the calculated PMV.

The results of the Wilcoxon Signed Rank tests for the performance tests are shown in Table 5. The Wilcoxon signed-rank tests showed that none of the sessions did elicit a statistically significant change ($p < 0.05$) in any performance. Indeed, median ratings were close to similar. The analysis of the test batteries performed in the afternoon alone did not show any significant differences either.

Table 4. Median, Z- and p-value of Wilcoxon signed rank tests for four items related to thermal comfort for the last two measurements of the day. Significant differences ($p < 0.05$) are marked with bold characters.

	Median			Result Wilcoxon signed rank test		
	i-	i+	iP	i- to i+	i+ to iP	i- to iP
Thermal sensation vote	5.00	4.45	5.05	-3.07 (.002)	-3.00 (.003)	-.14 (.886)
Thermal preference	-.67	-.36	-.64	-1.91 (.057)	-2.17 (.030)	-.073 (.942)
Thermal acceptance	-.76	-.59	-1.0	-1.09 (.276)	-2.50 (.012)	-1.14 (.253)
Neutral temperature	23.8	26.9	25.2	-3.63 (.000)	-2.66 (.008)	-2.21 (.027)
PMV	.67	.64	.69	-.295 (.768)	-1.96 (.050)	-1.20 (.230)

Table 5. Median, Z- and p-value of Wilcoxon signed rank tests for four items related to performance. “Speed” is the number of correct addition tasks per second, “number of correct links” is the number of correct links drawn on two sheets within 40 seconds each.

	Median			Result Wilcoxon signed rank test		
	i-	i+	iP	i- to i+	i+ to iP	i- to iP
Speed (Addition)	.080	.080	.077	-.469 (.639)	-.035 (.972)	-.785 (.433)
Number correct links (Tsai-Partington)	23.5	23.5	24.0	-.187 (.852)	-.226 (.821)	-.040 (.968)
Concentration performance (d2)	181	187	188	-.261 (.794)	-.052 (.958)	-.052 (.958)

5.2 Logistic model of ceiling fan usage

The logistic regression models for the ceiling fan usage during i+ and iP-sessions are similar (Fig. 10). In both cases, the operative temperature at which 50% of the subjects are using their ceiling fan is around 28°C. Table 6 shows the values for coefficients of the ceiling fan usage model during i+ sessions.

Linear models of the chosen strength (subjects could choose between 0% and 60% of the maximum speed) however show that at the same operative temperature a higher speed was chosen during iP-sessions compared to i+-sessions.

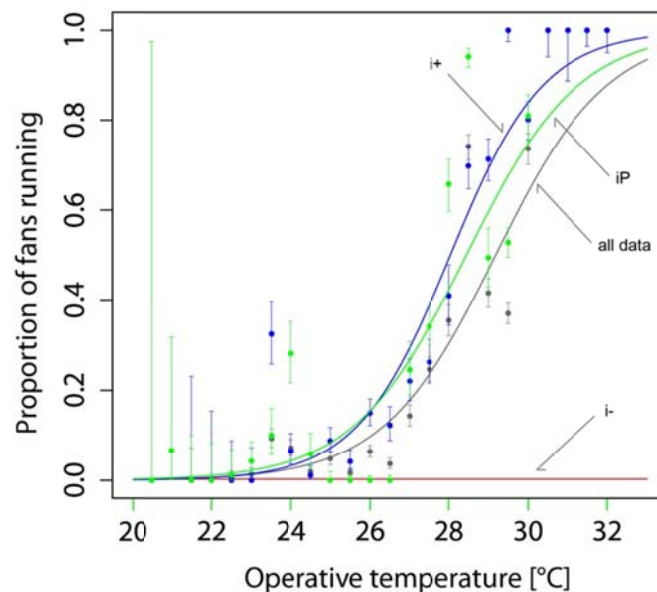

Figure 10. Observed and fitted probabilities to observe the ceiling fan running using the operative temperature as predictor for all data and individual session types

Table 6. Values of coefficients, standard error and probabilities of the ceiling fan usage model during i+ sessions (Nagelkerke's R^2 -index for model: .488)

	Value	Standard error	Probability
Intercept	-23.6	±.655	<0.001
Operative temperature	.841	±.0237	<0.001

5.3 Dynamic building simulation

Figure 11 shows the output of 1 of the 100 simulation runs with regard to outdoor air temperature, operative temperature and ceiling fan state. The data of the ceiling fan shows, that the model performs as one would suspect. The usage of the ceiling fan is higher during summer season, than in winter.

Due to the probabilistic character of the model, the usage pattern differs slightly from test run to test run. The minimum total usage time is 756hrs, the maximum 1028hrs with a mean of 893hrs and a standard deviation of 57hrs.

The number of hours outside the comfort range is 1811hrs during i- sessions and 941hrs during the i+ sessions. The comfort range for the i- sessions is $25.1^{\circ}\text{C} \pm 2\text{K}$ and for the i+ sessions it is $26.6^{\circ}\text{C} \pm 2\text{K}$. They were obtained using the mean of neutral temperatures stated above.

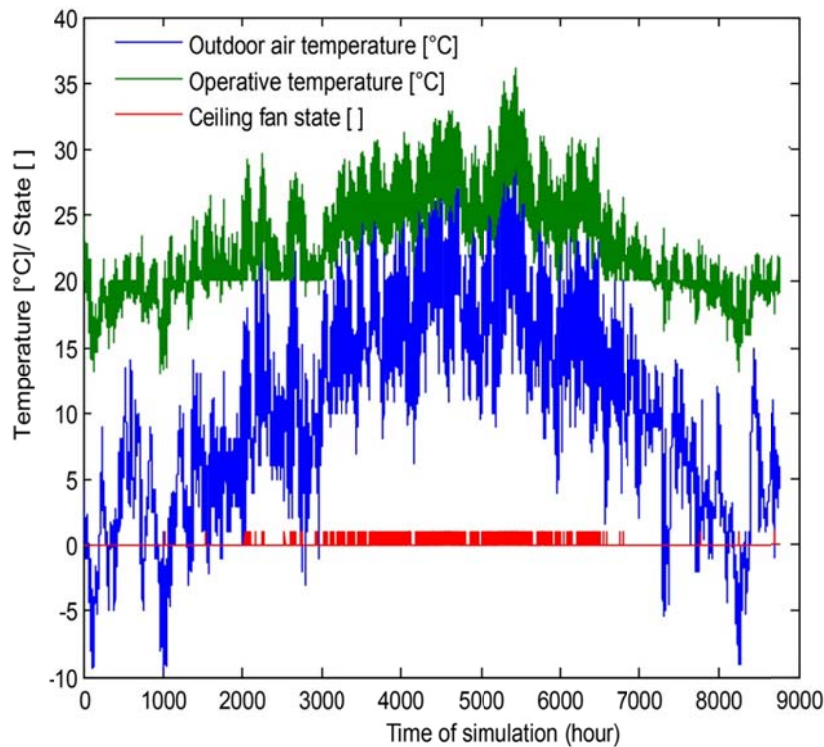

Figure 11. Output of 1 of 100 simulation runs using the probabilistic ceiling fan usage model.

6 Discussion and conclusions

As already shown in Schweiker et al. (2012), careful developed experimental designs implemented in a climate chamber having at least one window facing the exterior are suitable in order to reveal further insights into adaptive processes.

For this project, the effect and usage of a ceiling fan was chosen vicariously for other interactions to be researched. In contrast to the experiments presented in Schweiker et al. (2012), only the interaction opportunities of the ceiling fan differed, while occupants were allowed to open the window and/or use the ceiling fan at all times. Still, a statistically significant difference was found in the mean neutral temperatures for the sessions, when the usage of the ceiling fan was allowed compared to the ones it was not. This complies with findings of previous research (see e.g. Brager et al., 2004), which showed that occupants thermal sensations differs with the degree of control.

The iP sessions were intended to test a so-called placebo-effect of giving subjects control over the ceiling fan, while it does not have any effect. In reality, there was still a not neglectable effect on the air velocity due to the ceiling fan running in reverse mode. With a linear regression analysis, it was further shown that subjects reacted to the difference in the ceiling fan's performance by increasing the speed. In order to level out such effect, allowing the subjects the choice of a single speed could be a solution for further studies.

The analysis of differences in thermal comfort votes between the session types did partly show statistically significant differences, partly not. The analysis of the votes obtained at the last two measurements of each day showed that the neutral temperature, T_{nG} , differs significantly between the three session types. In Figure 9 can be seen, that the thermal sensation vote is higher for i+ sessions compared to i-

during the first periods. In the afternoon, the thermal sensation vote is lower, i.e. subjects perceived the conditions as more comfortable. This would support the hypothesis that at the beginning, having control positively influences on the occupants thermal sensation but at the end of the day, such control needs to be effective in order to remain such influence. An analysis compared to the theory of alliesthesia (Parkinson et al., 2012), is difficult to perform based on the existing data due to the number of interaction types and the lack of comfort votes close to the interactions.

The occupant behaviour model for the ceiling fan usage considered in this study – a multivariate logistic regression model – is compared to the models presented in the literature (see e.g. Haldi and Robinson, 2009) one of a simple type. Discrete-time Markov chain models and others would be usefully implemented in order to increase the validity of the results. Such analysis is beyond the scope of this paper and will be presented elsewhere.

The air movement and temperature distribution used for this analysis is based on a one-node-room model. This is valid for the measured data (taken in the middle of the room) as well as the simulated data. Therefore, the validity between statistical model and simulation is given. In order to increase the accuracy, detailed investigations of the air flow profile of the existing ceiling fan as presented in Voss et al. (2013), would be meaningful.

The dynamic building simulation showed, that the elevated comfort range due to the ceiling fan nearly halved the hours with temperatures above the comfort range. In the chosen case study, the resulting hours above the comfort level are with more than 800 hrs still above an acceptable number of around 260 hrs (= 3% of a year as denoted in DIN EN 15251). The reduction of hours outside the comfort range comes through a relatively easy measure.

The installation costs of a ceiling fan could be estimated depending on the situation between 150€ and 500€ per office. The running electricity cost for each ceiling fan can be calculated to be in average $893 \text{ hrs/a} \times 100 \text{ W} \times 0.25 \text{ ct/kWh} = 22.3 \text{ €/a}$.

In conclusion, the results suggest that it is not the control itself, which leads to a higher acceptance of increased indoor temperatures in summer, but the effectiveness of the control. For the analysis of the performance tests, only minor differences in the performance under the distinctive conditions were observed.

Comfort votes and simulation suggest, that the installation of a ceiling fan does not only improve thermal comfort of occupants, but could be a cost effective measure resulting in a lower cooling demand. Further, building concepts using naturally ventilation will work in a wider range of climate conditions.

Acknowledgement

This project is funded by the German Federal Ministry of Economics and Technology (BMWi) with the project ID: 0327241C. The new test facility LOBSTER was funded by the German Federal Ministry of Economics and Technology (BMWi) with the project ID: 03ET1035B and supported by industrial partners. The authors are indebted to the Baden-Württemberg Stiftung for the financial support of this research project by the Eliteprogramme for Postdocs.

References

- Ammons, CH (1955), Task for the study of perceptual learning and performance variables. *Perceptual and Motor Skills*, 5, 11-14.
- Brager GS, Paliaga G, de Dear R (2004), Operable windows, personal control, and occupant comfort, *ASHRAE Transactions* 2004;110(2), 17-35.
- Brickenkamp R (2002), Test d2-Aufmerksamkeits-Belastungs-Test, Manual. Göttingen: Hogrefe-Verlag GmbH.
- de Dear R, Brager G, Cooper D (1997), Developing an adaptive model of thermal comfort and preference, in: Final Report on ASHRAE Research Project 884, Macquarie University Sydney.
- DIN EN 15251 (2007), Indoor environmental input parameters for design and assessment of energy performance of buildings addressing indoor air quality, thermal environment, lighting and acoustics, German version EN 15251:2007.
- Fanger PO (1972), Thermal comfort, analysis and applications in environmental engineering. McGraw-Hill, New York.
- Haldi, F, Robinson, D (2012), Interactions with window openings by office occupants, *Building and Environment* 44, pp. 2378-2395.
- Humphreys MA, Nicol JF (1998), Understanding the adaptive approach to thermal comfort, *ASHRAE Transaction*, 104(1), 991-1004.
- Lang PJ, Greenwald MK, Bradley MM, Hamm AO (1993), Looking at pictures: affective, facial, visceral, and behavioral reactions, *Psychophysiology*, 30(3), 261-273.
- Nghiem, TX (2014), MLE+: a Matlab-EnergyPlus Co-simulation Interface, URL: <http://www.seas.upenn.edu/~nghiem/mleplus.html>, accessed 14.01.2014.
- Parkinson, T, de Dear, R, Candido, C (2012), Perception of Transient Thermal Environments: Pleasure and Alliesthesia, Proceedings of 7th Windsor Conference, Windsor, UK.
- Rijal HB, Tuohy P, Humphreys MA, Nicol JF, Samuel A, Raja IA, Clarke J (2008), Development of adaptive algorithms for the operation of windows, fans, and doors to predict thermal comfort and energy use in Pakistani buildings, *ASHRAE Transaction* 114(2), 555-573.
- Schweiker M, Brasche S, Bischof W, Hawighorst M, Voss K, Wagner A (2012), Development and validation of a methodology to challenge the adaptive comfort model, *Building and Environment*, 49, 336-347.
- Voss, K, Voß, T, Otto, J, Schweiker, M, Rodriguez-Ubinas, E (2013), Investigation of ceiling fans for improving summer thermal comfort, Proceedings of the 2nd Central European Symposium on Building Physics, Vienna, Austria, 9-11 September 2013.
- Wargocki, P., Wyon, D.P., Baik, Y.K., Clausen, G. and Fanger, P.O. (1999b), Perceived air quality, Sick Building Syndrome (SBS) symptoms and productivity in an office with two different pollution loads, *Indoor Air*, 9, 165–179.
- Wilcoxon, F. (1945), Individual Comparison by Ranking Methods, *Biometrics Bulletin*, (1)6, 80-83.

WINDSOR CONFERENCE 2014

COUNTING THE COST OF COMFORT

WORKSHOP 8

Negotiated comfort

Invited Chair: Gary Raw

WINDSOR CONFERENCE 2014

COUNTING THE COST OF COMFORT

THE WORKSHOP PROGRAMME

WORKSHOP 8: Negotiated Comfort

Invited Chair: Gary Raw

12th April 2014: 17.30 – 18.30 – Greening Room (1 Hour)

The temperatures to which people heat their homes result from a complex, continuous and dynamic negotiation, rather than a simple comfort temperature. This negotiation operates at two levels – between household members (who may desire different temperatures or other ways of feeling comfortable) and between objectives (e.g. being comfortable, keeping healthy, saving money, protecting the environment and avoiding conflict). This results in householders using a greater or lesser palette of possible means of achieving (or compromising on) comfort, depending on a set of competing priorities and the social and economic status of individuals within the household. The workshop aims to draw on participants' research and experience to fill in some of the key parameters in this negotiation.

Proceedings of 8th Windsor Conference: *Counting the Cost of Comfort in a changing world* Cumberland Lodge, Windsor, UK, 10-13 April 2014. London: Network for Comfort and Energy Use in Buildings, <http://nceub.org.uk>

Evaluating the effect of occupant behaviour and expectations on actual energy use and environmental conditions in ‘sustainable’ social housing in South East England

Professor Rajat Gupta¹ and Mariam Kapsali²

¹ Low Carbon Building Group, Oxford Institute for Sustainable Development, School of Architecture, Oxford Brookes University, rgupta@brookes.ac.uk

² Low Carbon Building Group, Oxford Institute for Sustainable Development, School of Architecture, Oxford Brookes University, mkapsali@brookes.ac.uk

Abstract

This paper investigates the effect of occupant behaviour and expectations on energy use and indoor environmental conditions of six case study dwellings in three sustainable social housing developments in UK using building performance evaluation methods. The case study houses cover a variety of built forms and different types of construction systems but have similar occupancy profiles and tenures. The study captures quantitative data on fabric performance, commissioning and controls, energy consumption and environmental conditions, cross-related with qualitative data gathered through questionnaires and interviews with occupants.

Despite all the developments being designed to Code for Sustainable homes level 4 or 5, the actual energy use across the six case study houses varies by a factor of 3.3, with high occupant expectations increasing the gap between designed and actual performance. To ensure that low energy houses perform as intended, occupants need to be trained through graduated (and extended) handover, supplemented by visual home user guides. Controls need to be designed and installed in a more intuitive and user-friendly way that encourages occupants to interact with their environment in an adaptive manner. Otherwise there is a risk that UK Government’s zero carbon housing policy may get undermined.

Keywords: building performance evaluation, low carbon houses, occupant behaviour, performance gap

1. Introduction

The UK Government has set ambitious targets for incremental changes to building regulatory standards, which are intended to achieve ‘zero’ carbon new housing from 2016 onwards (UKGBC, 2008) through the Code for Sustainable Homes (CSH¹) which promotes sustainable design principles and micro-generation technologies. However there is a growing concern that many of these proposals and solutions are untried and untested within the context of the mainstream housing production in the UK, creating a gap between predicted and actual performance (Gupta et al, 2013). Moreover this performance gap may undermine zero carbon housing policy and carry considerable commercial risk for the wider industrial sector (Zero Carbon Hub, 2010).

¹ CSH: Code for Sustainable Homes is a holistic standard for sustainable housing design and construction in the UK (Gaze et al., 2009)

The majority of the research on performance gap in the housing sector tends to focus on addressing differences between ‘as designed’ and ‘as built’ performance, highlighting the need for measuring actual fabric performance and commissioning reviews of services and systems (Windfield et al, 2011; Gupta and Dantsiou, 2012; Zero Carbon Hub, 2013). However, the energy performance gap tends to become wider at the in-use stage when occupants’ comprehension, understanding and behaviour also influence the households energy consumption (Stevenson and Rijal, 2010; Stevenson and Leaman, 2010). Several studies have revealed the need to understand occupant behaviour along with other performance mandates (Sharpe and Shearer, 2013). Lomas et al. (2006) highlight that one of the main reasons for limited success in achieving energy targets is the lack of understanding of how people interact with domestic technology. Firth et al (2008) found significant variation in energy consumption in similar dwellings underlining the need for qualitative and quantitative studies to explore the technical, socio-demographic and behavioural factors. Steemers and Yun (2009) demonstrated that the physical building characteristics, local environment, systems servicing the building and occupant behaviour all play a significant role in determining consumption. The study of Gill et al (2010) demonstrates a method to account for the contribution of occupant behaviour to performance variation using the post-occupancy evaluation (POE) and reveals that resource-conscious behaviours account for 51% and 37% of the variance in heat and electricity consumption respectively between the same type of dwellings.

Within this context, this paper investigates the effect of occupant behaviour and expectations on energy use and indoor environmental conditions in six case study dwellings across three ‘sustainable’ social housing developments in UK, through building performance evaluation methods. The case study houses cover a variety of built forms and different types of construction systems but tend to have similar occupancy profiles and tenures. It is found that occupant behaviour, expectations, understanding and lack of user control over heating and ventilation systems play an important role in influencing housing performance and needs to be addressed through a deeper understanding of occupant expectations and interactions with the building and technologies.

2. Methodology - Building Performance Evaluation

The study adopts a mixed-methods building performance evaluation (BPE) approach, which is socio-technical in nature. BPE is the process of evaluating the performance of a building through a systematic collection and analysis of qualitative and quantitative information related to energy performance, environmental conditions and occupant feedback.

The study has been sponsored by the UK Government’s Technology Strategy Board National Building Performance Evaluation (BPE) programme which is an £8m research programme, for both domestic and non-domestic buildings, to help the construction industry deliver more efficient, better performing buildings (TSB, 2012). The programme mandates a prescribed protocol for evaluation and reporting to maintain consistency and comparability in benchmarking and analysis.

This study involves capturing data on energy consumption, CO₂ emissions and environmental conditions including air quality and monitoring of opening and closing of doors and windows. This data is cross-related with qualitative data gathered through occupant satisfaction surveys and interviews, supplemented by occupant self-completion activity logging and thermal comfort diaries across different seasons. To

understand the design intent, walkthrough interviews are conducted with the design team and clients, while the communication of design intent to users is evaluated through observations of handover process and assessment of home user guides. A detailed review of control interfaces exposes challenges faced by occupants in terms of accessibility, usability and clarity of purpose.

3. Overview of case studies

The six case study dwellings are part of three exemplar social housing developments (A, B and C) located in South East England. The six case studies (two per development – A1, A2, B1, B2, C1 and C2) were selected to represent a variety of built forms and construction systems, with similarities in occupancy profiles. The case study houses are two and three storey mid-terrace, end-terrace and detached houses of two, three and five bedrooms, located in residential areas. The size of the properties varies between a minimum of 94m² to a maximum of 146m². The layout of the houses is similar, with the living areas on the ground floor and sleeping areas on the upper floors. While Cases A1, A2, C1 and C2 are being monitored for a period of two years and Cases B1 and B2 were monitored for a period of one year. Table 1 presents the background characteristics about the case studies, while Table 2 presents an overview of their design specifications and construction details.

Development A was designed for Code for Sustainable Homes 5 and Developments B and C were designed for Code for Sustainable Homes 4. Different types of construction were used in the three developments ranging from hempcrete in Development A to light-weight steel frame construction with pre-insulated panels in Development B and more traditional timber frame with brick in Development C. Additionally, each of the developments features a different heating system; from Exhaust Air Heat Pumps (EAHP) in Development A to Air Source Heat Pumps (ASHP) in Development B and gas boilers in Development C.

All of the six case study houses are occupied by families with children. The number of occupants in the case studies ranges between four to six. Occupancy patterns are similar between the case studies. Cases A1, A2 and B2 are occupied 24 hours/7 days a week, and Cases B1, C1 and C2 are occupied 17-19 hours during weekdays and 24 hours during weekends. The occupancy time in the properties is highly correlated with heating and ventilation interactions and controls. In terms of occupancy and use of space, interviews with occupants have shown that the most occupied area in all properties is the living area whereas bedrooms are mostly used during sleeping hours only.

Table 1 Case studies information

	Development A		Development B		Development C	
No of case study houses	2		2		2	
Case study reference	Case A1	Case A2	Case B1	Case B2	Case C1	Case C2
Area (m²)	94	94	88	123	128	146
Typology	Two bed, mid-terrace	Two bed, mid-terrace	Three bed, end-terrace	Four bed, mid-terrace	Four bed, mid-terrace	Five bed, detached
Floors	2	2	2	3	3	2
Occupancy patterns	Weekdays: 24h Weekend: 24h	Weekdays: 24h Weekend: 24h	Weekdays: 15:00-8:00 Weekend: 24h	Weekdays: 24h Weekend: 24h	Weekdays: 13:00-8:00 Weekend: 24h	Weekdays: 13:00-8:00 Weekend: 24h
Occupants	2 adults, 2 children	2 adults, 2 children	2 adults, 2 children	4 adults, 1 baby	2 adults, 3 children	1 adult, 5 children

Table 2 Design specifications and construction details

	Development A	Development B	Development C
Developer	Social housing / Local authority	Social housing / Local authority	Social housing / Local authority
Tenure	Mixed-private ownership, affordable housing rented	Mixed-private ownership, affordable housing rented	Mixed-private ownership, affordable housing rented
Construction type	Timber frame with cast hempcrete	Steel frame with pre-insulated panels	Timber frame and brick
Target design rating	CSH Level 5	CSH Level 4	CSH Level 4
Main construction elements (as designed) U-values W/m ² K	Walls: Rendered hempcrete cast into timber frame, U-value: 0.18 Roof: Tile on timber, U-value 0.15 Ground floor: Screed over insulation on beam and block, U-value 0.2 Windows: wood frame, double glazing, U-value 1.4	Walls: Light steel frame with pre-insulated panels, U-value: 0.15 Roof: Tile on timber, U-value: 0.15 Ground floor: Concrete over steel frame with Cube 6 EPS insulation block, U-value: 0.15 Windows: Timber frame, triple glazing, no trickle vents, U-value ≤1.2	Walls: Timber frame and brick, U-value 0.21 Roof: Slate roofing, U-value 0.13 Ground floor: Precast concrete with insulation, U-value 0.25 Windows: Aluminium frame, double glazing, U-value 1.3
Space heating and hot water system	Exhaust Air Heat Pump (EAHP), underfloor heating coils and 4m ² vacuum tube heat pipe solar collectors	Air Source Heat Pump (ASHP), underfloor heating coils, immersion heater back up	Gas condensing boiler with radiators
Target air tightness (m ³ /hm ² @50Pa)	2	3	3
Ventilation strategy	MEV through EAHP	MVHR	MVHR
Renewables	4kWpk Photovoltaics	1.5kWpk Photovoltaics	1.65kWp & 1.88kWp Photovoltaics

4. Actual energy performance

Monitoring data for energy consumption are provided for the period from January to December 2013 (Figure 1). Comparison of actual energy use with ‘as designed’ SAP predictions reveals discrepancies between them in all cases². Actual energy use exceeds the SAP prediction by a factor of 4 in Case C1 and by a factor of 5 in Case C2. In Cases B1 and B2 actual energy use exceeds the SAP predicted value by a factor of two. Cases A1 and A2, which were designed for CSH Level 5, present the highest discrepancy from their SAP predicted performance, exceeding the SAP energy use prediction by a factor of six and five respectively.

These discrepancies are partly due to the fact that SAP does not cover all end uses of energy in dwellings. To overcome this the SAP predictions were extended using a TSB spreadsheet that extends SAP 9.81 to make a whole house energy model, including appliances and the ability to model substantial reductions in them and also reset the constant whole house temperature to 21°C. This way a more accurate

² It should be noted that SAP calculations do not account for all end uses of energy such as appliances and lighting.

comparison can be made between the design predictions and the actual energy consumptions. Actual energy consumption exceeds the extended SAP prediction by a factor of 2 in Cases A2 and C1 and by a factor of 2.5 in Cases A1 and C2. Actual energy use in Cases B1 and B2 is a little higher than the SAP prediction. Actual CO₂ emissions³, however, are much higher than the extended SAP prediction in all cases, with cases A1 and A2 presenting the highest discrepancies exceeding the values of the extended SAP model by a factor of 7 and 5 respectively .

Cases A1 and A2, although designed to CSH Level 5, consume much more electricity than Cases B1 and B2 that have been designed for CSH Level 4. In Cases B1 and B2 the design COP of the ASHPs is 3.13 whereas in Cases A1 and A2 the designed COP is 2.6. Furthermore, the actual COP for Cases A1 and A2 has been measured at 1.4 resulting in the lower actual performance of the heating system. As a result of that the council has decided to remove the EAHPs from all houses in Development A and replace them with gas boilers. Cases C1 and C2 have a similar performance to a typical UK house, despite being designed to CSH Level 4. Annual CO₂ emissions across the six cases differ by a factor of 3.3 despite all the developments being designed for CSH Levels 4 and 5.

There is also significant variation in the energy consumption of houses within the same development designed to the same standard and with similar occupancy patterns (Table 1). In Development A, occupants in Case A2 appear energy conscious and actively try to reduce their electricity bills by keeping the thermostats at 19°C and heating the ground floor only. On the other hand, the qualitative data collected suggests the occupants in Case A1 cannot control the heating effectively due to lack of understanding of the underfloor heating system and control interfaces. To overcome this they closely follow the advice that they received by the housing officer during handover about ‘keeping the heating on at all times’, and never adjust the thermostats even during summer months and even when the temperatures in the house are above 25°C. As a result, CO₂ emissions and energy use of Case A1 exceed those of Case A2 by a factor of 1.3, despite the fact that they have similar occupancies (patterns and family size).

Lack of control also led occupants in Case B1 to turn off their heating system during the day, only heating the house during the night in order to reduce their energy bills, thus reducing the efficiency of the heat pump. CO₂ emissions and energy use of Case B1 exceed those of Case B2 by a factor of 1.2, despite the fact that Case B2 is occupied continuously.

The highest CO₂ emissions are observed in Cases C1 and C2 which have gas boilers for space heating and hot water. Energy use of Case C2 exceeds that of Case C1 by a factor of 1.5. In both houses occupants set their thermostats as high as 30°C throughout the day, but in Case C2 occupants tend to leave the windows open day and night even during winter thus increasing the heat loss and the heating demand.

These results imply the effect of occupant behaviour, understanding and control on energy consumption and the need to study these closely in relation to housing performance. To better understand the physical context and the cause for the

³ CO₂ emissions were calculated by using with the energy conversion factors quoted as kgCO₂e per unit of fuel. Grid electricity: 0.44548 kgCO₂e/kWh, Natural gas: 0.18404 kgCO₂e/kWh. The factors were taken from Carbon Trust 2013 update (Carbon Trust, 2013).

performance gap, it is vital to measure and compare the fabric and service performance of the houses.

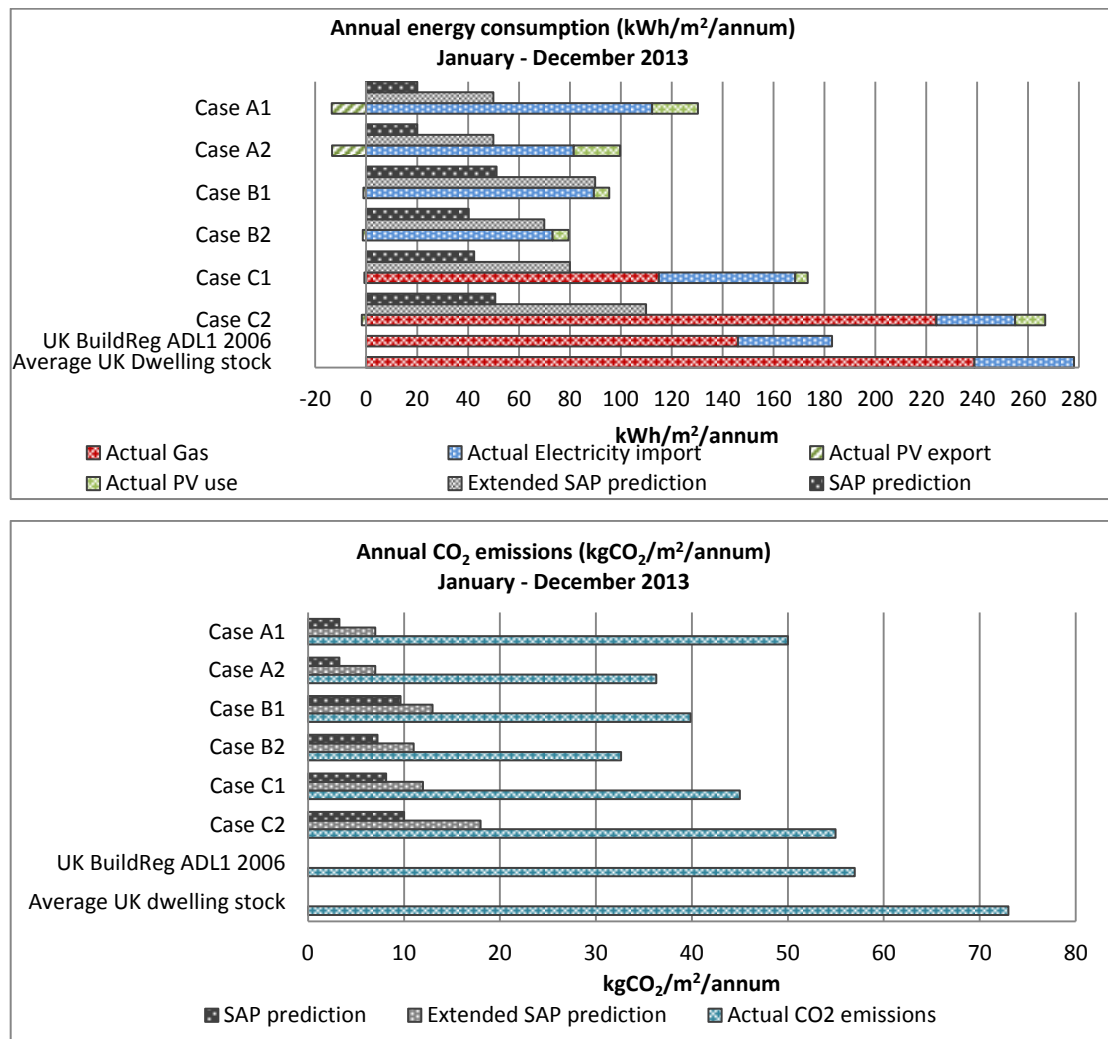

Figure 1 Comparison of actual annual energy consumption and CO₂ emissions with SAP predictions and Extended SAP model predictions across all cases (January – December 2013). Emission factors kgCO₂e per kWh: Electricity 0.44548, Gas 0.18404 (Carbon Trust, 2013).

5. Evaluation of fabric performance and services

5.1 Measuring in-situ fabric performance

The fabric performance of the case studies was evaluated using diagnostic field tests which include: air permeability test⁴, in situ U-value test and infrared thermography⁵. The common emerging issues across the three developments that were revealed from the assessment of the fabric performance are summarised in Table 3.

Wall insulation levels were found to be good in all cases. The findings from the in-situ U-value test showed that in Developments B and C actual wall U-values are similar or even better than those specified at the design stage. However, in all cases thermographic images revealed some heat loss through window and door frames, air

⁴ Air permeability tests or blower door tests help establish the air permeability and the heat loss due to air infiltration and exfiltration through the building fabric alone. Ventilation routes such as mechanical ventilation heat recovery (MVHR) units are sealed during the tests.

⁵ Infrared thermography visually renders thermal radiation from building elements helping locate heat related construction faults and leakage.

leakage paths and thermal bridges across thresholds. In some cases thermal bridges through ceiling beams and heat loss through party walls were also identified.

Air permeability tests revealed a noteworthy gap between designed and actual airtightness in all case studies. All homes missed their design target (2-3m³/m²h) with air permeability in most cases being twice as high as designed (Figure 2). All houses failed to comply with the UK Building Regulation Best practice air permeability rate (5m³/m².h) and Case A2 did not even meet the UK Building Regulation Good practice (10m³/m².h). Better air tightness would have resulted from a higher quality of detailing at key junctions, skirtings and service penetrations, and detailed care around door and window thresholds and seals.

Heat loss through walls and frames and air leakage paths can affect actual performance by increasing energy use and undermining occupant comfort. However, it is noticeable that occupants in Case A2, despite high air permeability, consume 30kWh/m²/annum less electricity than their neighbours in Case A1 (Figure 1). This comparison between similar houses within the same development that also have similar occupancies gives a strong indication of the effect of occupant behaviour and expectations on housing performance.

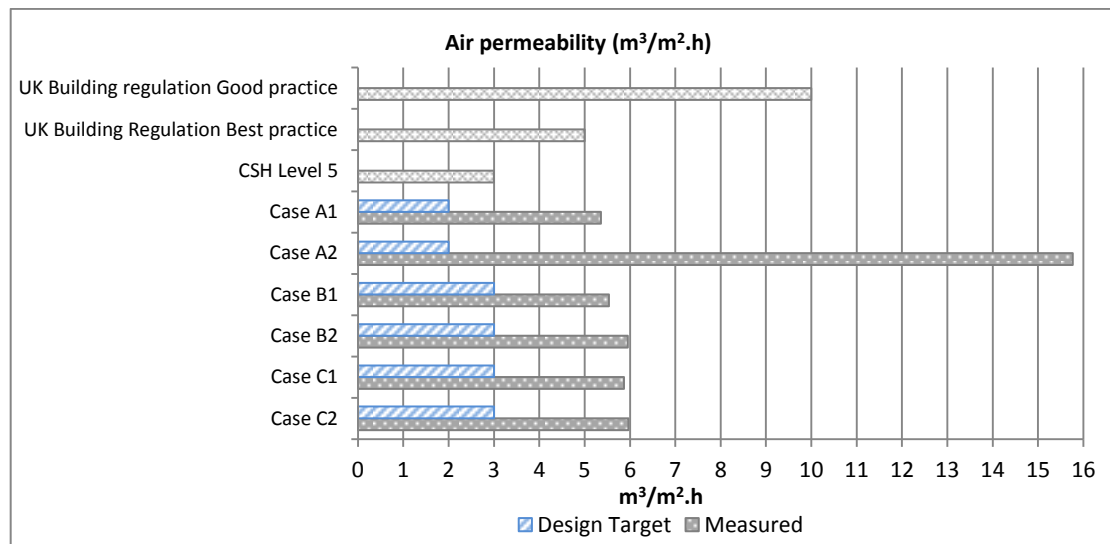

Figure 2 Comparison of measured and design air permeability.

Table 3 Common emerging issues highlighted by evaluation of fabric performance

	Development A	Development B	Development C
Heat loss through party walls	x	x	
Heat loss through external walls	x		
Heat loss through window and door frames	x	x	x
Thermal bridges in ceiling beams and/or thresholds	x	x	x
Actual U-values higher than design specifications	x		
Loft insulation not well distributed		x	x
Actual air-permeability much higher than design air permeability	x	x	x
Air-permeability rate did not meet UK Building Regulation Best practice (5 m ³ /h.m ²)	x	x	x

5.2 Systems installation and commissioning review

A commissioning review was undertaken in all the cases to ensure that the commissioning of equipment and services is complete and the design and operational strategy was capable of creating the desired performance and comfort for occupants. Table 4 summarises the common emerging issues across the three developments. The MVHR system installation and commissioning was found to be one of the most problematic issues in all six houses, along with improper commissioning of heating controls and room thermostats.

MVHR systems in these developments were adopted in order to achieve code compliance. In all cases the developers had little, if any, knowledge and experience in MVHR systems. In all the houses, the MVHR systems proved to be problematic with issues including; improper commissioning and system imbalance (all Cases), breakdowns (Cases B1, B2), noise (Case C1) and cold draughts (Case B1). The MVHR supply and extract vents in all cases were not locked in fixed positions allowing the occupants to adjust them at will thus leading to severe system imbalance, which in turn can lead to increased heat loss and energy use, as well as increased system resistance and noise.

Improper commissioning of the MVHR system not only allows occupants to fiddle with the vents but often results in unpleasant draughts which in turn undermines occupant comfort and appears to have driven occupants to look for ways to override the system. This also appears to have had a severe impact on indoor air quality due to insufficient fresh air supply. Additionally, the location of the MVHR unit in the loft (Cases B1, B2, C1, C2) makes the unit inaccessible and along with the narrow space provided compromises proper installation and maintenance.

The commissioning of heating controls and room thermostats was also found to be problematic in most houses. In Development A, a commissioning check before the move-in revealed that the zone thermostats were not properly connected. In Development B the wireless thermostats in both the case study houses had not been connected to the heating system and the heating was subsequently always on. This was discovered by the BPE team several months after the move-in following

occupants' complaints of not having good control over heating and of rooms being too hot. This commissioning problem made occupants in Cases B1 and B2 feel they lack control over heating and also made them sceptical towards the heat pump and the technologies used in the houses.

Installation and commissioning is clearly an area where increased training and awareness will have a large impact on improving the performance of houses.

Table 4 Common emerging issues highlighted by review of systems installation and commissioning

	Development A	Development B	Development C
MVHR imbalance between supply and extract air flow rates	x		x
MVHR unit located in loft inaccessible		x	x
MVHR vents not locked in fixed positions	x	x	x
MVHR vents shut by occupants		x	x
Several MVHR system breakdowns		x	
Occupants unaware of MVHR maintenance requirements	x	x	x
Poorly commissioned heating controls	x	x	

6. Environmental conditions and occupant interaction

Internal temperature data and occupant activities during the monitoring period (January – December 2013) reveal some insightful trends across all houses (Figures 3, 4). Overall temperatures are high with five out of six houses having mean living room and bedroom temperatures above 21°C and three out of six houses having a mean above 23°C. Peak temperatures above 27°C were also observed in the majority of the houses (five out of six). In Case A1, bedroom temperatures are 2°C lower than living room temperatures because occupants prefer to heat only the ground floor (living room and kitchen) and keep the first floor (bedrooms) unheated. Case B1 has the lowest minimum and average temperatures due to occupant's efforts to minimize their electricity bills by controlling the heating system and only heating their house during the night. Contrary to this, Cases A1 and C1 have the highest mean temperatures as the occupants use a lot of heating energy by keeping their thermostats around 25-27°C throughout the day. In Case C2 occupants also keep their thermostat very high throughout the day (30°C) but mean temperatures are around 21°C because occupants keep their windows open for many hours during the day (Figure 8), thus leading to the high gas consumption shown in Figure 1. In Case B2 bedroom temperatures are higher than living room temperatures because the heating in the first floor (bedrooms) was constantly on due to an error in the commissioning of the heating system. Figures for RH in the monitoring period suggest very low levels of relative humidity that are linked to the high indoor temperatures.

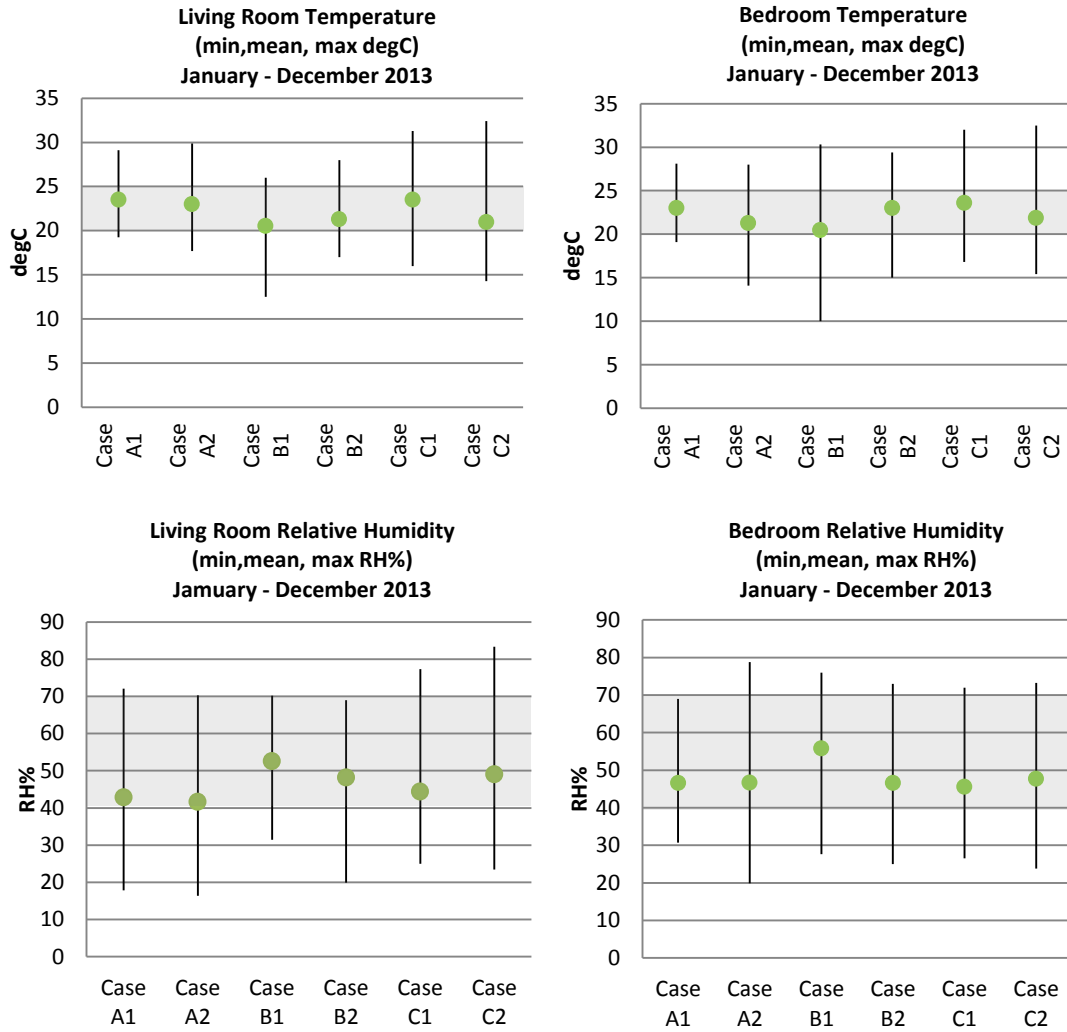

Figure 3 Mean, minimum and maximum temperatures and relative humidity levels in living rooms and bedrooms (January – December 2013).

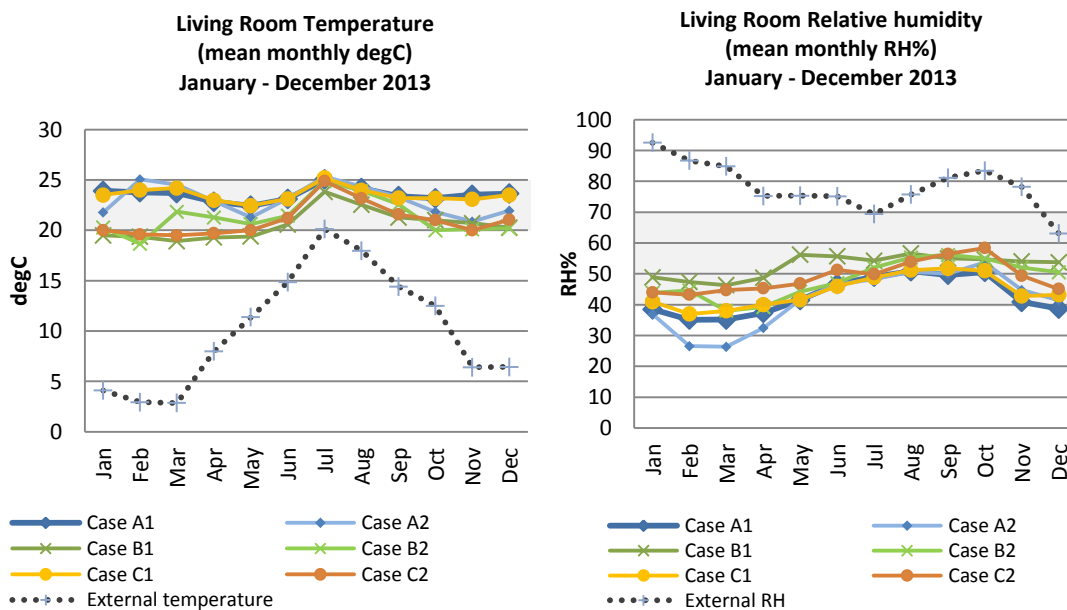

Figure 4 Mean monthly temperature and relative humidity in living rooms across all cases.

The temperature distribution throughout the year is shown in Figure 5. The majority of the houses (four out of six) show instances of overheating with temperatures remaining above 28°C for more than 1% of occupied hours (Case A1: 2%, Case B2: 1.1%, Case C1: 1.4%, Case C2: 2.3%). Interestingly, within the same development there are cases that show instances of overheating and others that do not. This indicates that overheating and summer performance is more related to internal heating gains and occupant activities such as window opening.

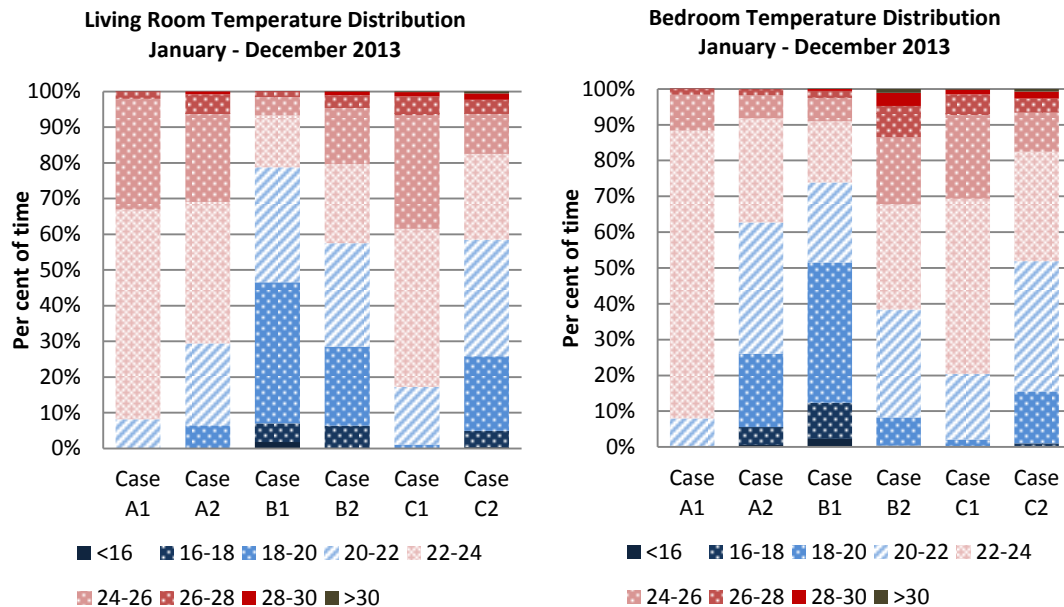

Figure 5 Temperature distribution in living rooms and bedrooms (January – December 2013).

CO₂ levels as an indicator of air quality is of particular interest in these dwellings, especially given the levels of airtightness. Mean, maximum and minimum CO₂ levels are shown in Figure 6. Mean CO₂ levels in Cases A1, A2, C1 and C2 range between 560-640ppm in the living rooms and between 650-730 in the bedrooms (CO₂ levels in Cases B1 and B2 were not monitored). Peak levels are well above 1000ppm in all cases, reaching 2270ppm in Case C2 living room and exceeding 2000ppm in Cases A2 and C1.

In order to evaluate the amount of time CO₂ levels are above the limit of 1000ppm during a year in each house Figure 7 was plotted. In Cases A1 and A2 CO₂ levels range between 500-750ppm for the majority of the time (50-60%). CO₂ levels are lower in Cases C1 and C2 living rooms with CO₂ levels remaining below 500ppm for 50% of the time. This is directly related to the window opening behaviour of occupants as analysis has shown that occupants in Cases C1 and C2 open their windows more frequently during winter than occupants in Cases A1 and A2 (Figure 8). In Cases A1, A2 and C1, CO₂ levels in the living rooms exceed 1000ppm for 3-4% of the time. CO₂ levels in the bedrooms are higher than those in the living rooms in all cases; exceeding 1000ppm for 4-6% of the time in Cases A1 and C2 and for 12-17% of the time in Cases A2 and C1. High bedroom CO₂ levels in Cases A2 and C1 are due to room occupancy levels (2 occupants per room during the night).

Overall, such high CO₂ levels indicate poor air quality, which appear related to insufficient supply of fresh air through the MVHR system. Given the fact that all of

the houses exceeded their design air permeability target these findings suggest that CO₂ levels could have been even higher had the design target been achieved.

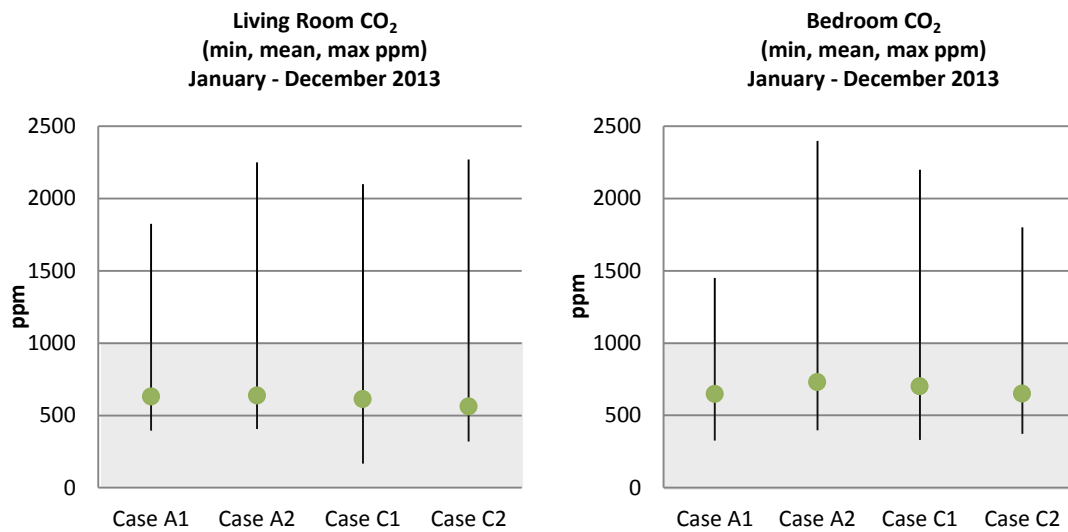

Figure 6 Mean, minimum and maximum CO₂ levels in living rooms and bedrooms (January – December 2013).

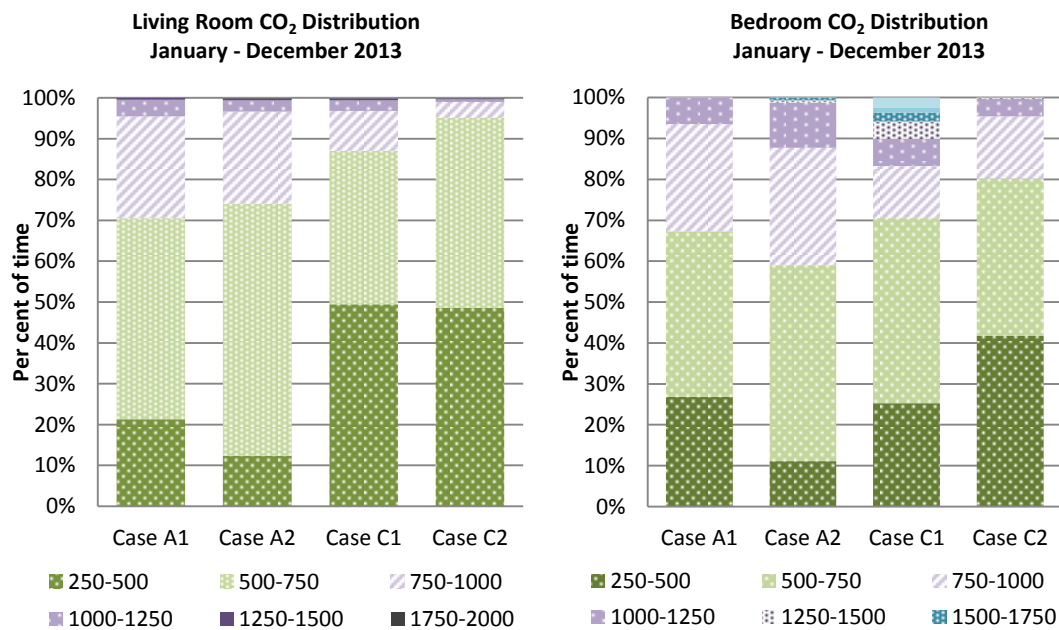

Figure 7 Distribution of CO₂ levels in living rooms and bedrooms (January – December 2013).

The hourly percentage of window opening in living rooms and bedrooms for winter and summer is plotted against hourly average internal temperatures in Figure 8. During winter, occupants in Cases A1 and A2 tend to mostly keep their windows closed and indoor hourly temperatures are kept steady throughout the day. In Case C1 occupants tend to open the living room window and back external door when indoor temperatures rise, whereas in Case C2 occupants leave the living room window open throughout the day. This behaviour explains the high energy use discussed in the previous sections.

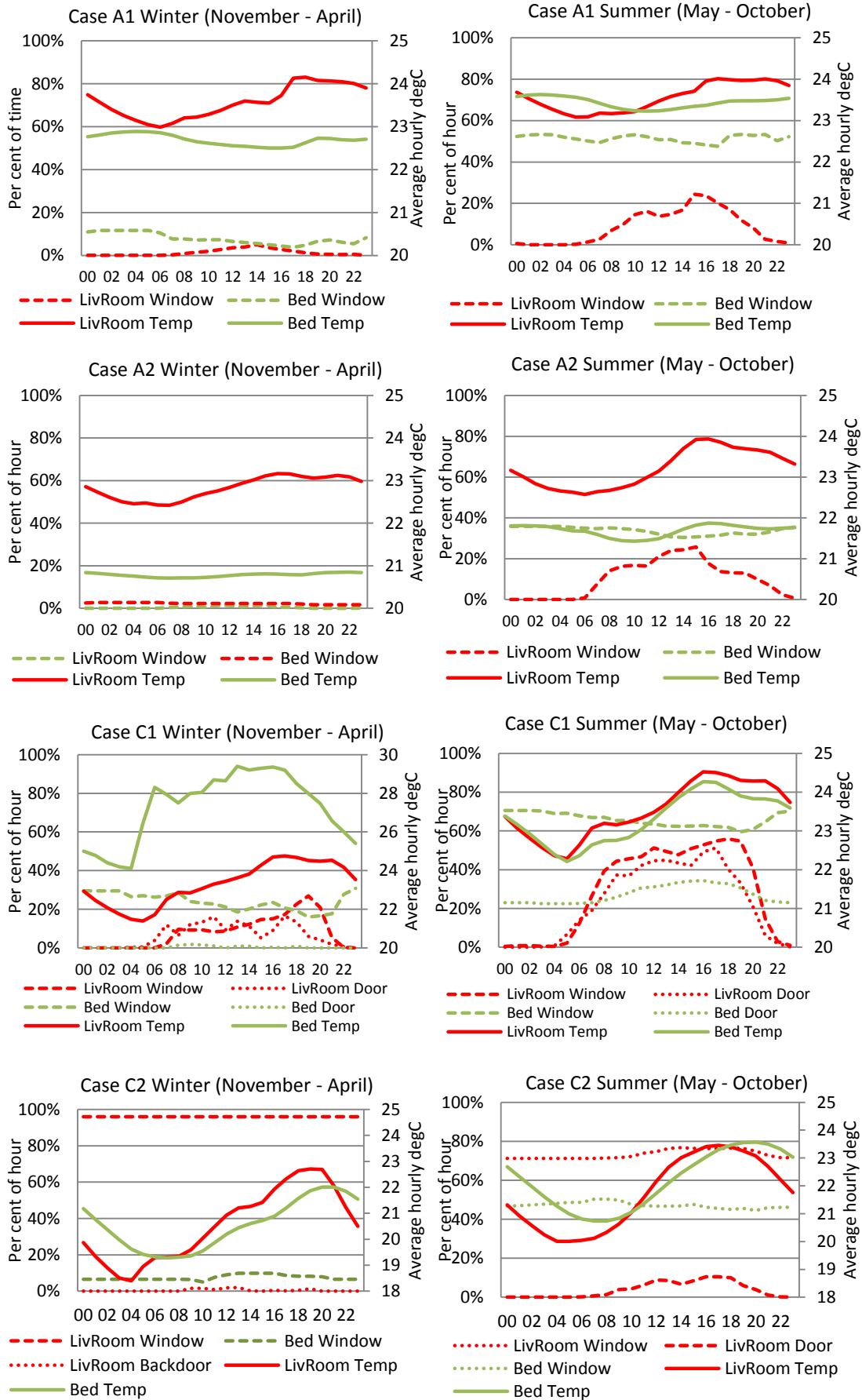

Figure 8 Hourly average temperatures and hourly percentage of window opening across a day.

As shown in the figures above, it is evident that demand temperatures in these houses are high and this is closely related to occupants' expectations of comfort. This level of demand is leading to a gap between design prediction and actual consumption in terms of both energy use and environmental conditions.

7. Occupant experience of operating systems and controls

7.1 User comprehension of systems through handover and user guidance

The handover process and documentation homeowners receive before and after moving into their new home was evaluated in order to gain better insight on the level of occupant understanding of the systems and to establish whether the information that the home owners received is sufficient in communicating the intent and operation of the new home without being overly technical or confusing. Table 5 lists the key findings from the evaluation of the handover and home user guide for all cases.

The study has shown that all local authorities, having experience of a large stock of homes and tenants, are more or less successful in organising and delivering comprehensive handovers and guidance. In Cases A and B the handover demonstrations were simple and clear but were missing some aspects like discussion on handover documentation and hands-on application by occupants. In Case C no phased approach was followed, undermining the occupants' potential of retaining information.

The review of Home User Guides showed that the guides generally contain extensive technical details but do not provide clear guidelines on how to make better use of systems on a daily and seasonal basis. This potentially has a negative impact on user understanding on how to control, operate and maintain the systems.

Follow-up conversations and interviews with occupants have revealed that, in all the three developments, some occupants have failed to understand the purpose and operation of the systems or have forgotten the information that was provided to them initially. Significant risk has been identified regarding the amount of information that the occupants can absorb on the day of the handover. Findings indicate the need for a graduated handover, as well as repetition, hands-on application and clear guidance but also suggest that attention to guidelines is a matter of personal interest.

Table 5 Common emerging issues highlighted by the review of handover and user guidance

	Development A	Development B	Development C
Handover			
Phased approach during handover	x	x	
Handover was clear and simple	x	x	
PV system was explained	x	x	x
Heating system and controls were explained	x	x	x
Handover would have benefited by follow-up sessions	x	x	x
Handover lacked hands-on application by occupants	x	x	x
Home User Guide			
Document was clear and visual			x
Guidelines on daily operation of systems and controls			
Information was missing	x	x	
Home user was long and confusing	x	x	
Contact information and troubleshooting guidance	x	x	x

7.2 Usability of control interfaces

Control interfaces are the meeting point between the users and the building technology. Investigations into the relationship between the design and usability of controls give an indication of their effect on occupant control and dwelling performance⁶ (Topouzi, 2013). Table 6 summarises the key issues that emerge as a result of the review of control interfaces across the six case study houses.

Provision of usable and accessible controls for the MVHR system was an issue for all cases. In Cases A1 and A2 boost buttons are located in the unit cupboard on the first floor but occupants in both houses were not aware of it. The MVHR units in Developments B and C are located in the loft spaces which are very narrow and not easily accessible for maintenance. In Development B changes in the original ventilation and heating strategy late in the design stage led to complications and inadequate space provisions. Poor control over ventilation and poor maintenance has a negative impact on occupant satisfaction and indoor air quality.

Heating controls and thermostats were also found to be problematic in Developments A and B, but for different reasons. In Development B the designer's intention to provide occupants with good levels of control resulted in an excessive use of over-designed thermostats and zones that confuse the occupants and complicated commissioning. On the other hand, oversimplified control interfaces like the ones used in Development A led to similar results in terms of the occupant's understanding and use. Unclear, oversimplified or overcomplicated control strategies have a negative

⁶ The six-point criteria (clarity of purpose, intuitive switching, usefulness of labelling and annotation, ease of use, indication of system response, degree of fine control, accessibility) developed by Buildings Controls Industry Association (BCIA) is used to evaluate control interfaces (Bordass et al, 2007).

impact on the user's ability to understand and control the systems for optimal comfort and may increase energy use.

Table 6 Common emerging issues highlighted by review of control interfaces

	Development A	Development B	Development C
Conflicting control strategies (masterstat and room thermostats)	x	x	
Oversimplified control interfaces (no indication of system response, no labelling)	x		
Overcomplicated heating controls and zoning		x	
No indication of MVHR failure or maintenance	x	x	x
MVHR unit inaccessible, located in loft		x	x
Windows and doors intuitive and with good fine control		x	x

8. Assessing occupant expectations and satisfaction

8.1 Occupant satisfaction survey

Occupant surveys were carried out in all three developments using BUS questionnaires to assess occupant expectations and satisfaction. Questionnaires were collected from eight houses in Development A, sixteen houses in Development B, and eight houses in Development C. Table 7 lists the positive and negative feedback from the BUS analysis of the three developments (n=32).

Findings give an overall positive opinion of the developments with most elements scoring similar or above the current BUS domestic benchmark (Figure 9). In all developments space, design, layout and appearance were rated favourably. However, control over ventilation and heating was found to be an issue in all developments.

Despite being designed as 'sustainable' housing developments, occupants in all developments consider energy bills to be high. Interestingly, control over heating was rated poorly in Developments A and B that feature heat pumps and underfloor heating. Control over ventilation is rated low in Development B as occupants are confused with the purpose and operation of the MVHR system and underfloor heating.

Dedicated storage space is one of the aspects that was not rated very favourably in Developments A and B as much of the cupboard space is taken up by systems especially since no extra storage provisions were made by the designers.

Overall, the occupant survey indicated that occupants are not very familiar with new technologies such as heat pumps, underfloor heating and MVHR systems and are confused with their operation. This lack of understanding renders occupants sceptical towards these technologies and undermines occupant comfort.

Table 7 Common emerging issues highlighted by occupant satisfaction survey.

	Development A	Development B	Development C
Positive feedback			
Good overall comfort	x	x	x
Satisfaction with space and layout	x	x	x
Satisfaction with design and appearance	x	x	x
Satisfaction with location		x	x
Satisfaction with light levels (natural, artificial)	x		x
Good storage space			x
Temperatures good overall	x	x	x
Air quality good overall	x	x	x
Negative feedback			
Poor control over heating	x	x	
Poor control over ventilation		x	
Hot during summer		x	
Low daylight levels		x	
Lack of dedicated storage space	x	x	
Noise between houses	x	x	
High energy bills	x	x	x

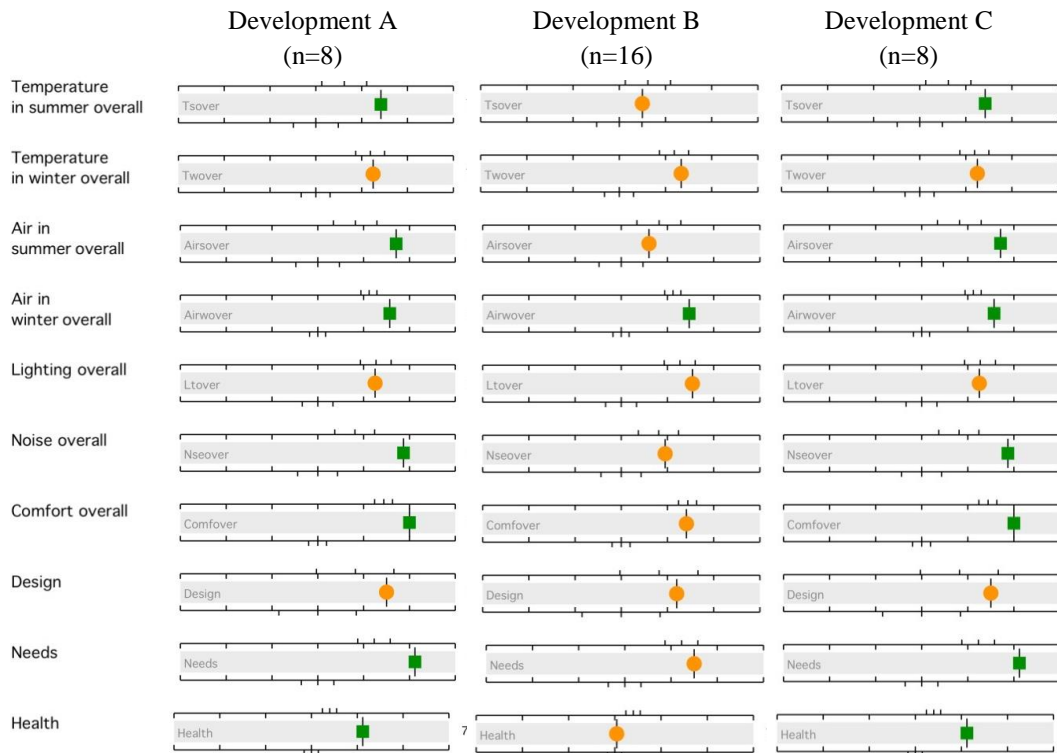

Figure 9 Overall findings from BUS survey in all cases (green=higher than benchmark, amber=similar to benchmark)

8.2 Insights from interviews and walkthroughs

Following the occupant surveys, more detailed information on occupant views, satisfaction and concerns was gathered through semi-structured interviews and walkthroughs with the occupants of the six case study houses. Table 8 summarizes the positive and negative feedback given by the occupants of the six houses during the interviews.

Similar to the results of the occupant survey, occupants in all three developments are fairly satisfied with the appearance, design and space of the houses. Most negative feedback involves the operation and control of the heating and MVHR system. Occupants in Developments A and B feel they do not have enough guidance on how to operate the heat pumps on a daily and seasonal basis and find the Home User Guide confusing. Occupants in Cases A1, A2 and B1 also reported that the guidance they receive is often contradictory and that technicians sent out by the council are not always familiar with the technologies installed in the houses. In addition to this, most occupants are unsatisfied with their electricity bills and occupants in Cases A1, A2 and B1 are dissatisfied with the performance of their heating system.

In Case C2, although the occupants appear to be satisfied with the induction process home user guide, when asked about the purpose and operation of the MVHR and the performance of the PV panels, they were found to be completely unfamiliar with these technologies. This indicates that the information given during the induction process failed to be absorbed by the occupants and also indicates that occupants may have been reluctant to read the home user guide. Despite the fact that occupants within the same development have received the same training and guidance documents, big discrepancies were observed in the level of understanding between different houses, suggesting that attention to guidelines is a matter of personal commitment and motivation; and not just a matter of knowledge and access to information.

Control over ventilation and heating is one of the primary issues affecting occupant comfort. Occupants in Case A1 are confused with how to control the heating and are more dissatisfied with comfort and temperatures than their neighbours in Case A2. Alternatively, faults with commissioning in Development B have left occupants feeling less in control of their thermal environment and have had negative impacts on comfort levels. In some cases MVHR was perceived to be the cause of high electricity bills as it is 'always on'. Lack of understanding of the purpose, consumption and operation of the MVHR system, resulting from inadequate handover and guidance, in combination with poor commissioning that created noise and unpleasant draughts, made most occupants sceptical towards the system, with some occupants actively closing the supply vents or looking for ways to de-activate the system, thus leading to a potential negative impact on indoor air quality and energy use.

Findings from the interviews indicate that it is challenging to engage occupants in social housing developments and improve their motivation in relation to operating and maintaining the houses. Moreover the combination of many new technologies, unfamiliar to both the occupants and the developers, leads to lack of comprehension.

Table 8 Common emerging issues highlighted by occupant interviews and walkthroughs.

	Case A1	Case A2	Case B1	Case B2	Case C1	Case C2
Positive feedback						
Satisfaction with space	x	x	x	x	x	x
Satisfaction with design and layout		x		x	x	
Satisfaction with daylight	x	x	x		x	
Satisfaction with location		x	x	x	x	
Satisfaction with appearance		x	x	x	x	x
Negative feedback						
Home User Guide considered complicated.	x	x	x			x
Occupants feel lack of control over heating	x	x	x	x		
Dissatisfaction with heating system performance	x	x	x			
Lack of understanding of heating system	x	x	x	x		
Lack of knowledge about MVHR	x	x	x	x	x	x
Draughts and/or noise from MVHR			x		x	
Lack of knowledge about PV panels	x			x	x	
Lack of dedicated storage space	x		x	x		
Noise problems between houses	x			x		x
Occupants think their energy bills are high	x	x	x		x	x

9. Discussion on findings

The key findings from the study of the six case study houses are listed in Table 9. It is clear that energy use in houses depends heavily on the occupants' expectation of comfort and their attempts to attain comfortable conditions. Satisfaction with thermal comfort appears to be closely linked to the level of understanding and control over the heating and ventilation systems in terms of accessibility, clarity of purpose, intuitive switching, usefulness of labelling and annotation, ease of use, indication of system response and degree of fine control.

High indoor temperatures that exceed design assumptions indicate high occupant expectations. Poor air quality, due to inefficient fresh air supply from the MVHR system, along with high occupant expectations, leads to activities such as opening windows when the heating is on during winter. Such behaviours help explain the discrepancies between the designed and actual performance of houses and also between houses of similar occupancies within the same development.

Occupants in most of the case study houses lack understanding of the systems installed, their purpose, operation and energy consumption. Lack of knowledge, on the daily and seasonal operation of systems and maintenance requirements, due to poor or confusing guidance, leads to poor use of systems and subsequently increased energy use. Poor commissioning of heating and ventilation leads to system inefficiency. In particular inadequate commissioning of MVHR system appears to have led to a system imbalance creating an insufficient fresh air supply and as a result, poor indoor air quality and high energy consumption. Additionally, it may lead to draughts and noise that increase occupant discomfort and leads occupants to shut the supply vents or de-activating the units.

Conflicting, confusing and unintuitive heating controls has led to poor occupant control over heating which in turn has a negative effect on comfort and impacts on increased energy use and indoor temperatures. The same applies for inaccessible MVHR controls that have a negative impact on indoor air quality and user satisfaction. Overall findings indicate that lack of control and understanding, resulting from poor commissioning and non-intuitive control interfaces, undermines occupant comfort and has a negative impact on energy consumption.

Table 9 Key findings from the BPE study elements and their effect occupant behavior and energy use

	Findings	Effect on occupant behaviour and energy use	Recommendations
Fabric performance	<ul style="list-style-type: none"> • Good wall insulation. Fabric first approach works well. • Thermal bridging across thresholds and beams. Heat loss through party walls. Heat loss through window and door frames. • Air permeability rates much higher than design specifications. Many air leakage paths. 	<ul style="list-style-type: none"> • Positive impact on indoor temperatures. Increased occupant comfort and expectations. • Undermine envelope performance. Negative impact on occupant comfort and energy use. 	<ul style="list-style-type: none"> • Detailing and construction needs more focus to avoid thermal bridges and air leakage paths and ensure airtightness. • Better communication of expectations from design to construction. Improve onsite communication, training and support.
Review of systems installation and commissioning	<ul style="list-style-type: none"> • Heating system and control not properly commissioned. • MVHR not properly commissioned, vents not locked. System imbalance. Units in lofts inaccessible. Ducts not insulated. • Undersized services and appliance cupboards. 	<ul style="list-style-type: none"> • System inefficiency. Poor occupant control over heating and undermines occupant comfort • System imbalance. Negative impact on energy use and indoor air quality due to insufficient fresh air supply. Draughts and noise increase occupant discomfort undermines IAQ. • Lack of dedicated storage space and occupant dissatisfaction. Occupants use the loft space for storage. 	<ul style="list-style-type: none"> • Installation and commissioning procedures to be more robust, training of engineers and technicians. • Stronger coordination for services, space needs and design.
Energy & Environmental monitoring	<ul style="list-style-type: none"> • High temperatures in spaces in winter. Overheating during summer. High thermostat settings. • High CO₂ levels in spaces. • Big discrepancy between designed and actual performance. CO₂ emissions across the six cases differ by 10-23kgCO₂/m². 	<ul style="list-style-type: none"> • High occupant expectations. • Not sufficient fresh air supply from MVHR. Window opening when the heating is on during winter. • Gap between designed and actual performance. 	<ul style="list-style-type: none"> • Occupant training and awareness. • On-going energy monitoring and feedback.

<p>Review of handover process and user guidance</p>	<ul style="list-style-type: none"> • Handover phased approach needed. Handover without follow-up and hands-on experimentation. • Home User Guide long and uninviting. Not clear instructions on daily system management. Unnecessary specification details. • Lack of information on daily and seasonal operation of systems. 	<ul style="list-style-type: none"> • Little information is being retained. • Occupants reluctant to read through guide. • Poor use of systems and increased energy use. 	<ul style="list-style-type: none"> • Well timed, phased training, hands on demonstration. System operation should be explained in a very simple and easy-to-follow way, without technical information, and should only focus on daily and seasonal routines for optimum use. • Visual, simple but comprehensive guides with information on daily and seasonal operation. Avoid technical specification details.
<p>Review of control interfaces</p>	<ul style="list-style-type: none"> • Conflicting and confusing, unintuitive heating controls. Oversimplified or overdesigned. • MVHR controls without indication of system response. MVHR unit inaccessible. No indication of maintenance or failure. Occupants unaware of boost button. 	<ul style="list-style-type: none"> • Poor occupant control over heating. Negative effect on comfort. Increased energy use and indoor temperatures. • Poor understanding and control over ventilation. Negative impact on indoor air quality and user satisfaction. 	<ul style="list-style-type: none"> • Design controls at initial stages to be accessible, intuitive and with indication of system response, faults and maintenance.
<p>Occupant satisfaction survey & Interviews with occupants</p>	<ul style="list-style-type: none"> • Occupants are satisfied with space, design, appearance and layout. • Occupants are very appreciative of good daylight levels. • Poor control over heating and ventilation. • High energy bills 	<ul style="list-style-type: none"> • Occupant needs and comfort improved. High expectations. • Undermines occupant comfort and has negative impact on energy consumption and IAQ. 	<ul style="list-style-type: none"> • Empowerment through sense of control. • Occupants need to gain good understanding or the relationship between their daily practices and energy bills. • Occupants need to fully understand how to operate systems and services.

10. Conclusions and recommendations

The overall objective of this research was to evaluate the effect of occupant behaviour, understanding and control on housing performance using a case study based approach. Case study results showed that occupant expectations and perception of comfort has a significant impact on energy consumption and environmental performance of houses with similar family size and occupancy; actual energy use varies by a factor up to 1.5 between houses of similar occupancy within the same development. Actual energy use between houses of different developments varies by a factor of 3.3. Occupants have been recognized as one of the best instruments for measuring housing performance, even if they are hard to calibrate (Cole et al., 2008), and their feedback can quickly demonstrate why a technology does or does not work, as demonstrated in this study. A mixed-methods BPE approach is a robust way to

assess the contribution of occupant behaviours to actual energy use and environmental conditions and to reveal the reasons behind the performance gap.

This kind of feedback, provided by the occupants as they inhabit their homes, cross-related with physical monitoring can be fed back into improving the modelling and design of housing as well its management and maintenance in order to reduce carbon emissions.

In order to ensure that low-energy dwellings perform as intended, occupants need to be trained through graduated and extended handover that involves hands-on demonstration, supplemented by visual home user guides offering clear guidance on the daily and seasonal operation of systems and controls. System operation should be explained in a very simple and easy-to-follow way, without unnecessary technical information. Furthermore, occupants need to gain a clear understanding of the effect of their daily activities on energy consumption and controls through energy monitoring and feedback. Informing occupants of the relationship between daily activities, habits and energy bills and showing them ways to actively reduce their fuel bills could attract their interest.

Findings highlight the need for integrating a controls and systems strategy early in the design process. An easy-to-understand but detailed and coordinated services layout plan showing location of systems and controls will provide the basis for a clear and straightforward strategy that occupants need to follow. Controls need to be designed and installed in a more intuitive and user-friendly way that encourages occupants to interact with their environment in an adaptive and positive manner. Strong coordination is required between services and space provisions to avoid any unintended consequences related to access to controls especially for mechanical ventilation.

It has been shown that the installation and commissioning of services and systems influences occupant comfort which is why seasonal commissioning (by certified and experienced engineers) needs to be encouraged for houses with technologies such as heat pumps and MVHR systems. Finally learning from real-world case studies (physical data and stories) is an insightful way for understanding the reasons behind the performance gap between design and actual performance, in order to achieve low carbon housing in practice. This requires a formalized briefing, commissioning and feedback protocol, such as ‘Soft Landings’, that has started to be used in some domestic projects. This will help to ensure that these lessons are captured and fed back to the developers, constructors and the designers. Otherwise there is a risk that UK Government’s zero carbon housing policy may get undermined.

References

Bordass, B., Leaman, A., Bunn, R., 2007. Controls for End Users: A guide for good design and implementations, Building Controls Industry Association (BCIA), www.bsria.co.uk

Carbon Trust, 2013. CTL153 Conversion factors. http://www.carbontrust.com/media/18223/ctl153_conversion_factors.pdf Accessed 14 March 2014.

Cole, R.J., Robinson, J., Brown, Z. and O’Shea, M. (2008) Re-contextualizing the notion of comfort. *Building Research & Information*, 36(4), 323–336.

- Firth, S., Lomas, K., Wright, A., Wall, R. 2008. Identifying trends in the use of domestic appliances from household electricity consumption measurements. *Energy and Buildings*, 40, 926-936.
- Gaze, C., Walker, A.F., Hodgson, G., Priaulx, M., 2009. The Code for Sustainable Homes simply explained. <http://www.appg-sustainablehousing.org.uk>.
- GHA (Good Homes Alliance), 2011. GHA monitoring programme 2009–11: Technical report. <http://www.goodhomes.org.uk>.
- Gill, Z.M., Tierney, M.J., Pegg I.M., Allan, N., 2010. Low energy dwellings: the contribution of behaviours to actual performance. *Building Research and Information*, 38:5, 491-508.
- Gupta, R., Dantsiou, D., 2012. Understanding the Gap between as Designed and as Built Performance of a New Low Carbon Housing Development in UK . Proc of the 4rd International Conference in Sustainability in Energy and Buildings (SEB'12).
- Gupta R., Gregg, M., Cherian, R., 2013. Tackling the performance gap between design intent and actual outcomes of new low/zero carbon housing, ECEEE Summer Study proc.
- Lomas, K., Summerfield, A., 2006. COBRA: Understanding the Social and Technical Factors that Influence Energy Use in UK Homes. *Carbon Reduction in Buildings* (CaRB) (ed.).
- Sharpe, T., Shearer, D., 2013. Scenario testing of the energy and environmental performance of the 'Glasgow House', Proc PLEA, Munich, Germany 10-12 September 2013.
- Stemers, K., Yun, G.Y., 2009. Household energy consumption: a study of the role of occupants. *Building Research and Information*, 37(5-6), 625-637.
- Stevenson, F., Carmona-Andreu, I., Hancock, M., 2013. The usability of controls interfaces in low-carbon housing, *Architectural Science Review*, 56:1, 70-82
- Stevenson, F., Rijal, H.B., 2010. Developing occupancy feedback from a prototype to improve housing production, *Building Research & Information*, 38:5, 549-563
- Topouzi, M., 2013. Low-carbon refurbishments: How passive or active are technologies, users and their interaction?, Proc ECEEE Summer study, p 2297-2309
- UKGBC (United Kingdom Green Building Council), 2008. The definition of zero carbon, Zero Carbon Task Group report.
- TSB (Technology Strategy Board), 2012. Competition: Building Performance Evaluation webpage, <http://www.innovateuk.org>.
- Windfield, J., Bell, M., Miles-Shenton, D., Seavers, J., 2011. Elm Tree Mews Field Trial. CeBE Report <http://www.leedsmet.ac.uk/as/cebe/projects/elmtree>
- Zero Carbon Hub, 2013. Closing the gap between designed and as-built performance. <http://www.zerocarbonhub.org>. July 2013
- Zero Carbon Hub, 2010. Carbon compliance for tomorrow's new homes - Topic 4: Closing the gap between designed and as-built performance. <http://www.zerocarbonhub.org>. August 2010

Acknowledgements

We are grateful to UK Government's Technology Strategy Board's BPE programme for funding these research projects. Our sincere thanks to the occupants, clients and project design teams for their help and support during the studies. We also wish to thank Mathew Gregg for his contribution to the paper.

WINDSOR CONFERENCE 2014

COUNTING THE COST OF COMFORT

WORKSHOP 9

Standards: Development of EN15251

Invited Chair: Bjarne Olesen

WINDSOR CONFERENCE 2014

COUNTING THE COST OF COMFORT

THE WORKSHOP PROGRAMME

WORKSHOP 9: Standard prEN15251 and new standard ISO-DIS 17772

Invited Chair: Bjarne Olesen

12th April 2014: 17.30 – 18.30 – Hodgson Room (1 Hour)

This workshop will deal with the *Revised Standard prEN15251* and *New Standard ISO-DIS 17772* on indoor environmental criteria for design and energy calculation of buildings and HVAC systems. EN15251 standard includes indoor environmental input parameters for the design and assessment of energy performance of buildings. It is a basic standard for the EPB standards dealing with design and energy performance of buildings including heating, cooling, ventilation and lighting systems together with acoustic. The standard recommends criteria for the indoor environment (thermal comfort, air quality, illumination and acoustic) which must be used as input parameters in several other EPB standards for design and energy calculations. The new standard will be rewritten to include only normative text. It will then be accompanied by+ a technical report (guideline, TR15251). An important new part will be a series of standardized occupant schedules to be used in energy calculations. In parallel a similar ISO standard NW17772 is being developed. The workshop will present the draft standards and accompanying technical report followed by a discussion of some of the issues. Reference and comparison to ASHRAE standard 55-2013 and 62.1-2013 will also be drawn to put the issues in both a European and a US perspective.

A New Hybrid Thermal Comfort Guideline for the Netherlands (ISSO 74: 2014)

A.C. Boerstra¹, J. van Hoof^{2,3} & A.M. van Weele²

- 1) BBA Binnenmilieu, The Hague, the Netherlands (email: ab-bba@binnenmilieu.nl)
- 2) ISSO / Dutch Building Services Research Institute, Rotterdam, the Netherlands
- 3) Fontys University of Applied Sciences, Centre for Healthcare and Technology, Eindhoven, the Netherlands

Abstract

In 2004 the first adaptive thermal comfort guideline was introduced in the Netherlands. Recently a new, upgraded version of this ISSO 74 (ATG) guideline has been developed. The new requirements are hybrid in nature as the 2014 version of the guideline combines elements of traditional non-adaptive comfort standards with elements of adaptive standards. This paper describes the new guideline and explains the rationale behind it. Also changes in comparison with the original 2004 version and issues related to performance verification are discussed. The information presented in this paper can be used by others (other countries) as inspiration material for other new adaptive comfort guidelines and standards.

Keywords: adaptive comfort, standardisation, overheating, personal control, classification

1 Introduction

During the late 1970s the first guidelines for thermal comfort were developed for use in the Netherlands, which were based on the PMV-PPD relationship and ISO-EN 7730. Since then, the Netherlands have developed successive guidelines [1,2], that include the Weighted Temperature Exceeding Hours method (GTO in Dutch) and - in analogy with international developments in the field of adaptive thermal comfort [3,4] - the Adaptive Temperature Limits method (ATG in Dutch). The latter was presented for the first time in 2004 in ISSO publication 74 and is known internationally as the ISSO 74: 2004 Dutch adaptive thermal comfort guideline. In 2012-2013 a new version was developed of the ISSO 74 guideline. This guideline will be published in 2014. This paper describes this new version of ISSO 74 and explains its practical and scientific backgrounds and gives guidance on how to apply the new guideline in practice.

2 International context

Thermal comfort contributes to overall satisfaction, well-being and performance, and is an important parameter in the building design process. In the 1970s and 1980s, the development and usage of energy balance models of the human body came within the focus of human biometeorology [5]. The most important contributor was P.O. Fanger, who created a predictive model for general, or whole-body, thermal comfort during the second half of the 1960s from laboratory and climate chamber research [6]. With his work, Fanger wanted to present a method for use by the heating and air-conditioning engineer, to predict, all those

combinations of the thermal factors in the environment for which the largest possible percentage of a given group of people experience thermal comfort [7]. Fanger stated at the time that his PMV-model (Predicted Mean Vote) was intended for application by the HVAC industry in the creation of artificial climates in controlled spaces [8]. The PMV-model became the internationally accepted model for describing the predicted mean thermal perception of building occupants.

An alternative predictive thermal comfort model, primarily based on the results of field studies, is generically called the adaptive model and also has been researched since the 1960s [9,10]. According to the adaptive hypothesis, contextual factors and past thermal history modify the occupant's thermal expectations and preferences [4]. In warm climate zones or during prolonged periods with warmer weather people supposedly prefer higher indoor temperatures than in cold climate zones or during prolonged periods of colder weather. This is in contrast with the assumptions underlying comfort standards based on the PMV/PPD-model [4,11]. Note that adaptation in this context is defined as the gradual lessening of the human response to repeated environmental stimulation, and can be behavioral, physiological, as well as psychological [4]. In practice, differences in the perception of the thermal environment were found among occupants of naturally ventilated (also referred to as free-running), fully air-conditioned and mixed mode (hybrid) buildings. According to Brager and de Dear [12], the PMV-model is not applicable to naturally ventilated buildings, because it only partly accounts for thermal adaptation to the indoor environment. Therefore, a model of adaptive thermal comfort has been proposed for free-running buildings; a model that relates the neutral temperature (comfort temperature) indoors to the temperature outdoors [12,13]. This alternative or complementary model is the fundament of the adaptive comfort requirements in, for instance, ASHRAE standard 55 [14], Annex A2 of EN 15251 [15] or the CIBSE TM 51 guideline [16].

One of the challenges when redesigning the ISSO 74 guideline was to combine, whenever possible and appropriate, the non-adaptive and the adaptive approaches as described above.

3 Methods

In 2012 ISSO, the Dutch Building Services Research Institute, took the initiative to revise the first (2004) version of the ISSO 74 guideline. ISSO recruited an expert team to rewrite the existing standard (the authors of this article) and organised a supervisory commission. This commission consisted of representatives from the national government, stakeholders in the construction and HVAC industry and of indoor climate specialist from research institutes and universities.

Beforehand the authors were told that the new thermal comfort guideline had to differ in several ways from the original guideline:

- The new guideline had to be better tuned in with the adaptive thermal comfort approach as described in Annex A2 of EN 15251; this implied that the new requirements had to be based on the SCATs database (in analogy with the requirements in Annex A2 of EN 15251) instead of on the RP 884 database (as was the original version of ISSO 74);
- The new ISSO 74 was supposed to also give guidance for optimal temperatures outside the cooling season (during the heating season);

- The new ISSO 74 - whenever possible and appropriate - had to integrate and combine adaptive and non-adaptive requirements; which should make the new guideline truly hybrid;
- Ideally the new guideline also had to take into account the beneficiary effects of personal control.

The expert team started with a review of the international (adaptive) thermal comfort literature. Also several innovative thermal comfort standards from abroad were analysed, including:

- the American ASHRAE standard 55 [14];
- the European EN 15251 standard (in particular, Annex A2) [15];
- the British CIBSE TM 52 guideline [16];
- the Swiss SN 180 guideline [17];
- the Chinese GB/T 50785 standard [18].

The new requirements and the new proposals for verification procedures were developed during interactive meetings / workshops with the stakeholders in the supervisory commission. And several draft versions of the new ISSO 74 guideline were commented upon by the different stakeholders in the supervisory commission.

4 The revised guideline

In this paragraph we describe the revised version of the ISSO 74 guideline.

In order to find out which limits one has to use for the operative temperature in a specific building one has to determine two aspects:

1. whether one deals with a type α or a type β situation (room, building), and;
2. what classification level should be used (class A, B, C or D).

One should use the decision scheme presented in Figure 1 in order to find out whether the α or β requirements should be used. In the context of the revised guideline, α refers to free-running situations in summer with operable windows and other adaptive opportunities for the occupants, whereas β refers to summer situations that primarily rely on centrally-controlled cooling.

Note: In Figure 1 an early exit option is described entitled ‘Temperature limit correction for unusual clo/met value’. This will not be explained in detail, but in order to get a first indication on what kind of temperature correction to use given unusual high metabolism or clothing values, please refer to Olesen [23].

The temperature requirements themselves are presented in the Figures 2 to 5. In order to know which schemes to use one first has to decide which classification level is applicable given the situation. In order to determine this, one should use the data presented in Table 1.

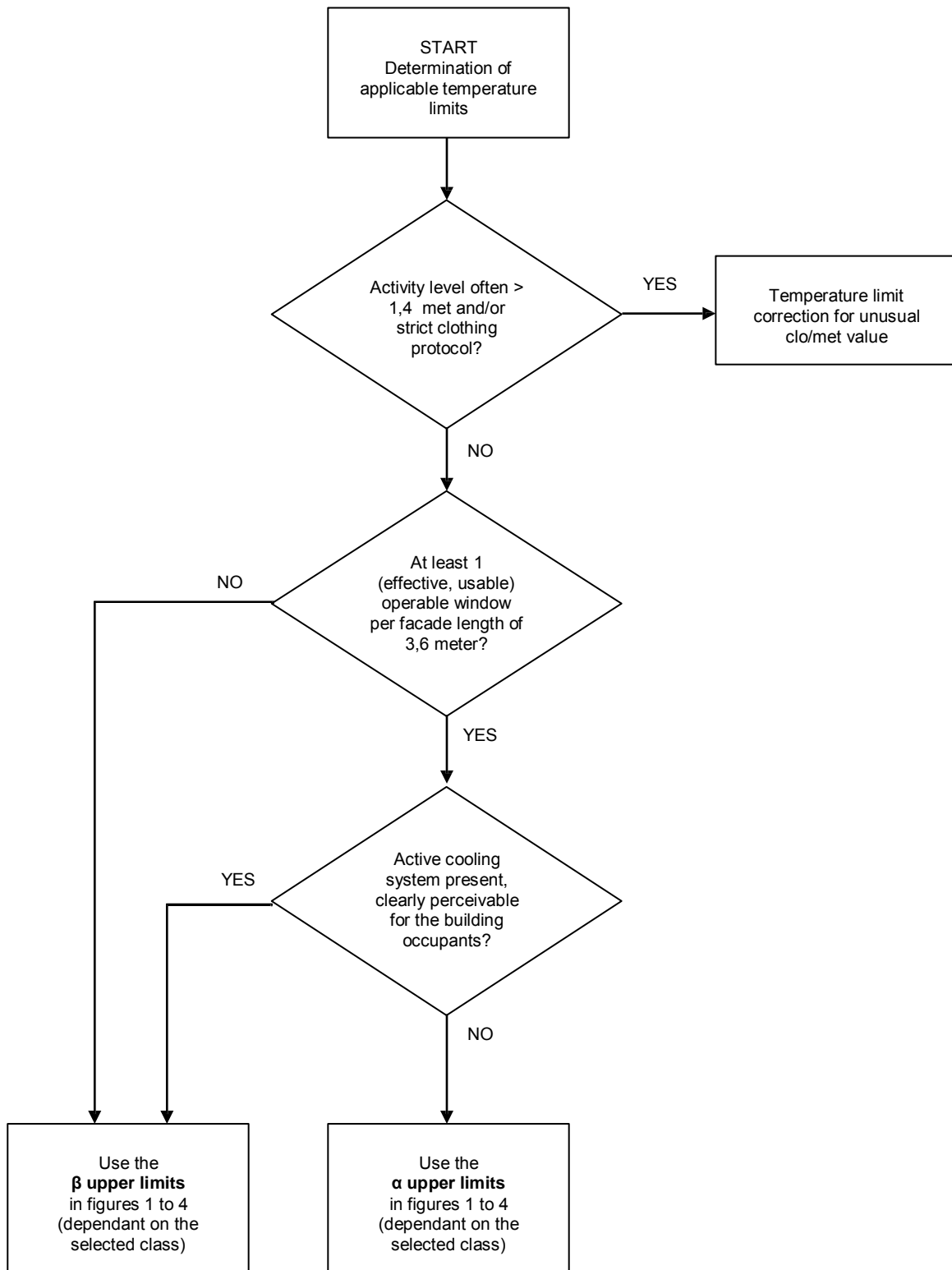

Figure 1. Decision scheme from ISSO 74:2014 that describes how one can determine whether the α or the β upper limits should be used

Table 1. Description of the 4 classification levels

Class (bandwidth)	Explanation	Percentage Dissatisfied	PMV analogy (bandwidth)
A	High level of expectation. Select this category as reference when designing spaces for people with limited load capacity (for instance, extra sensitive people) or when extra luxury is asked for.	max. 5%	-
B	Normal level of expectation. Select this category as reference when designing or measuring new buildings or in the case of substantial renovations	max. 10%	-0.5 < PMV < +0.5
C	Moderate level of expectation. Select this category as reference in the case of limited renovations or when measuring older existing buildings	max. 15%	-0.7 < PMV < +0.7
D	Limited level of expectation. Select this category as reference in the case of temporarily buildings or limited use (for instance, 1 to 2 hours of occupation per day)	max. 25%	-1.0 < PMV < +1.0

As far as the details of the figures are concerned:

On the x-axis we find the running mean outdoor temperature Θ_{rm} . In accordance to EN 15251 [15], this unit is defined as the exponentially weighted running mean of the daily mean external air temperature Θ_{ed} and is calculated with the following equation:

$$\Theta_{rm} = (1 - 0,8) \cdot \{ \Theta_{ed-1} + (0,8) \cdot \Theta_{ed-2} + (0,8)^2 \cdot \Theta_{ed-3} + \dots \}$$

This equation can be simplified to:

$$\Theta_{rm} = (1 - 0,8) \cdot \Theta_{ed-1} + 0,8 \cdot \Theta_{rm-1}$$

Where:

Θ_{rm} = Running mean temperature for today;

Θ_{rm-1} = Running mean temperature for previous day;

Θ_{ed-1} is the daily mean external temperature for the previous day;

Θ_{ed-2} is the daily mean external temperature for the day before and so on.

The following approximate equation (with a 7 day 'horizon') can be used whenever records of daily mean outdoor temperature are not available:

$$\Theta_{rm} = 0,253 \cdot \{ \Theta_{ed-1} + 0,8 \cdot \Theta_{ed-2} + (0,8)^2 \cdot \Theta_{ed-3} + (0,8)^3 \cdot \Theta_{ed-4} + (0,8)^4 \cdot \Theta_{ed-5} + (0,8)^5 \cdot \Theta_{ed-6} + (0,8)^6 \cdot \Theta_{ed-7} \}$$

On the y-axis of the figures we refer to the operative temperature indoors (not the air temperature). This implies that also radiant temperature effects are taken into account.

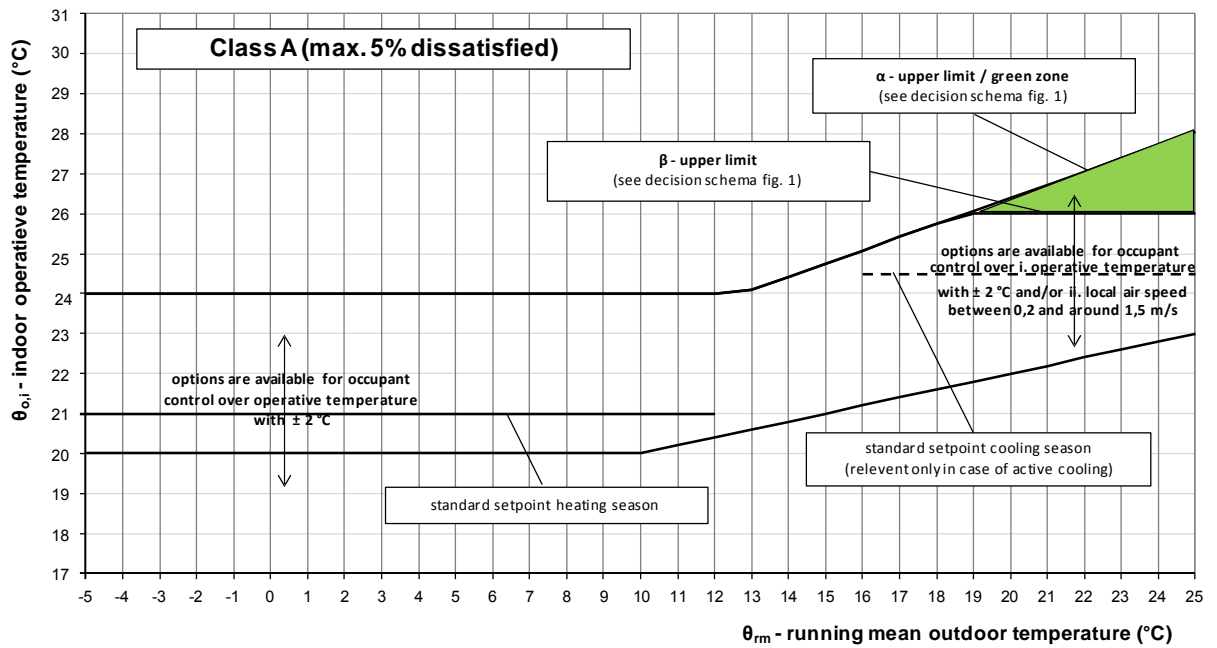

Figure 2. Class A requirements in ISO 74:2014 for the operative temperature indoors in relation to the running mean outdoor temperature

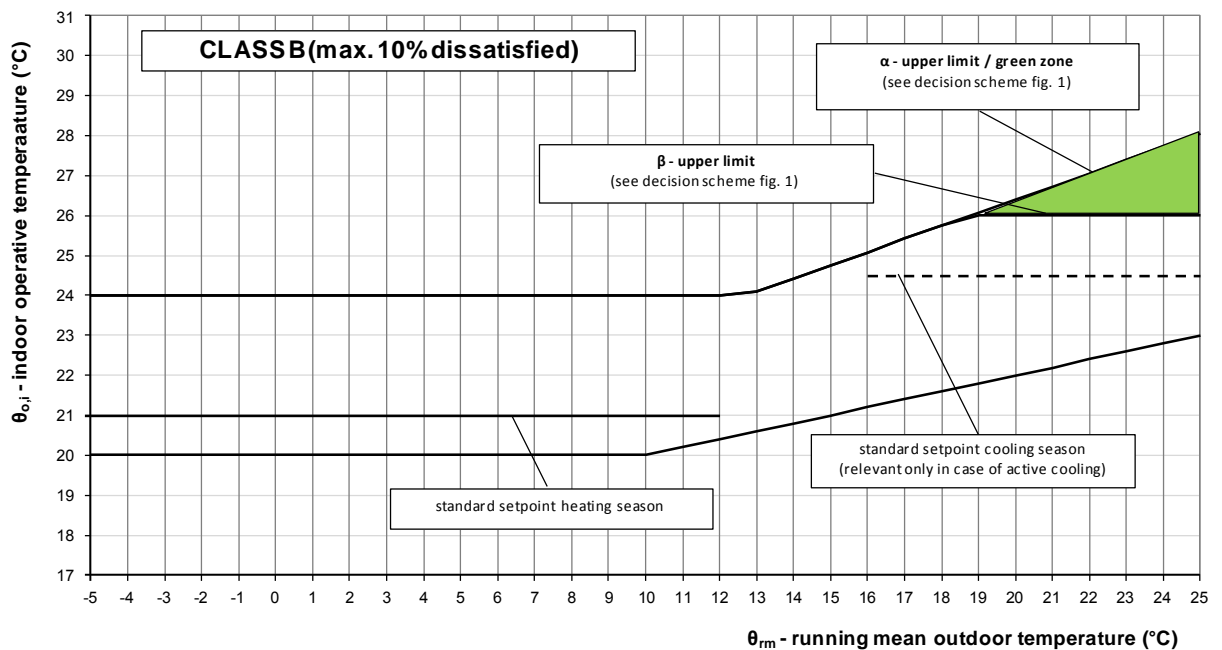

Figure 3. Class B requirements in ISO 74:2014 for the operative temperature indoors in relation to the running mean outdoor temperature

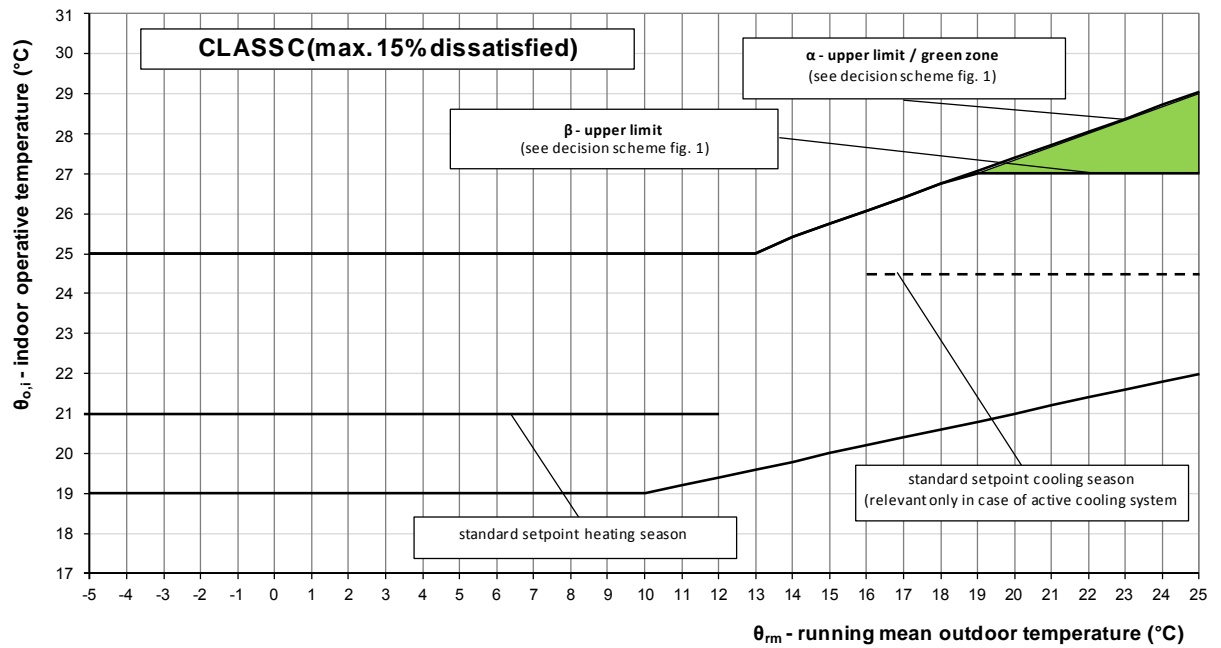

Figure 4. Class C requirements in ISSO 74:2014 for the operative temperature indoors in relation to the running mean outdoor temperature

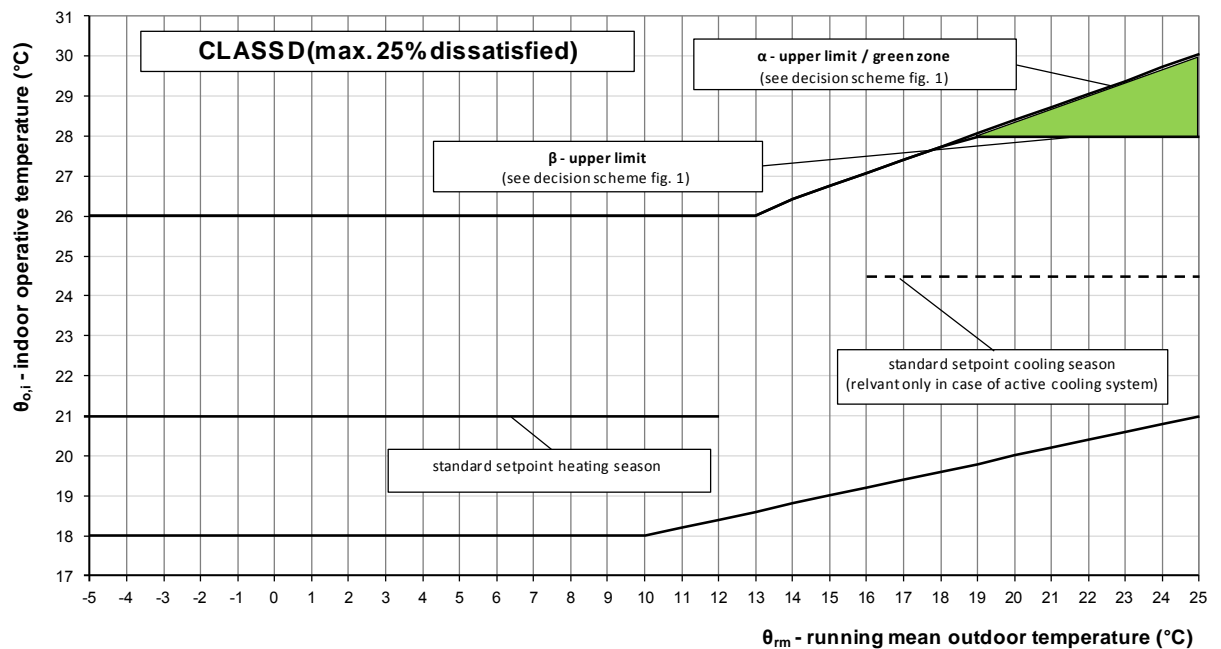

Figure 5. Class D requirements in ISSO 74:2014 for the operative temperature indoors in relation to the running mean outdoor temperature

5 Explanation and Discussion

The lines in the figures refer to the upper and lower limits for the operative temperature indoors. The operative temperature is not allowed to go over the upper limits or under the lower limits, at least not during normal occupancy times. For a further explanation of the lines and for the equations behind the lines (Table 2).

Table 2. Equation behind the class A, B, C and D lines as presented in the Figures 2 to 5 (based upon [15,16,19,20])

		Requirements indoor operative temperature (°C)		
		Winter	In-between-seasons	Summer
General	Setpoint line	21		24.5
Class A (PD approx. 5%)	Upper limit	See class B (+ occupant control requirement, ± 2 K)		
	Lower limit	See class B (+ occupant control requirement, ± 2 K)		
Class B (PD approx. 10%)	Upper limit	24*	$18.8 + 0.33 \cdot \tau_{rm} + 1^{**}$	type β spaces: 26* type α spaces: $18.8 + 0.33 \cdot \tau_{rm} + 1$
	Lower limit	20*	$20 + 0.2 \cdot (\tau_{rm} - 10)^{***}$	
Class C (PD approx. 15%)	Upper limit	25*	$18.8 + 0.33 \cdot \tau_{rm} + 2^{**}$	type β spaces: 27* type α spaces: $18.8 + 0.33 \cdot \tau_{rm} + 2$
	Lower limit	19*	$19 + 0.2 \cdot (\tau_{rm} - 10)^{***}$	
Class D (PD approx. 25%)	Upper limit	26****	$18.8 + 0.33 \cdot \tau_{rm} + 3^{**}$	type β spaces: 28**** type α spaces: $18.8 + 0.33 \cdot \tau_{rm} + 3$
	Lower limit	18****	$18 + 0.2 \cdot (\tau_{rm} - 10)^{***}$	
* based upon the standard class B and C winter limits mentioned in EN-ISO 7730				
** based upon the SCATs database comfort temperature equation [15] and the P-equations presented in [16] and [19]				
*** lower limits summer are derived by extrapolation; with starting point $x = \tau_{rm}$ of 10 °C and $y =$ lower limit winter [20] (different for each class) and end point $x = \tau_{rm}$ of 25 °C (maximum value x-axis given the Dutch outdoor climate) and $y =$ lower limit summer [20] (also different for each class)				
**** new (non-adaptive) limit values for the new class D, in line with the limits mentioned in [18]				

Note that the class C and D upper limits of Table 2 for the in-between-seasons (type α and type β spaces) and the summer season (type α spaces only) as mentioned in Table 2 are the same as (for Class C) the adaptive category I and (for class D) the category II upper limit lines presented in Annex A2 of EN 15251. Please note that the class A requirements are the same as those used for class B. A special workshop with the supervisory commission revealed that it does not make much sense within the Dutch context (see also [22]) to use stricter requirements than the class B ones (referring to a $-0.5 < PMV < +0.5$ bandwidth or a PPD=10% situation) mentioned in EN-ISO 7730. The group decided not to copy the

relatively strict class A ($-0.2 < PMV < +0.2$ / $PPD=6\%$) requirements from EN-ISO 7730, but, instead, to define the highest quality level, in analogy with the approach of FiSIAQ [21] in terms of options for occupant control.

If a building and its HVAC system is designed and operated in such a way that the operative temperature normally stays between the class B limits as mentioned in Table 2: it is a class B building. If the building and its HVAC system is designed and operated in such a way that the operative temperature normally stays between these limits and occupants (at room level or workstation level) can control local temperatures with ± 2 K (both in summer and winter; round the set-points mentioned in Table 2 - see also the dotted lines in Figures 2 to 5) than a building is regarded as a class A buildings. In some cases only occupant control over room temperature during the winter will be provided for (think of adjustable thermostats on radiators). In that case we speak of class B+ buildings.

The positions of the diagonal upper limits for the in-between-seasons and the summer season (type α spaces only) were determined with the P-equation as presented in the CIBSE TM 52 guideline [16]:

The likelihood of discomfort from heat (generally accepted as ASHRAE vote = +2 or +3) has been derived from a logistic regression analysis based on comfort surveys in European office buildings (Nicol and Humphreys, 2007). It gives the proportion P of subjects voting 'warm' or 'hot' on the ASHRAE comfort scale (the accepted definition of discomfort from heat) as (see Figure 9):

$$P = \frac{e^{(0.4734 \Delta T_{\text{diff}} - 2.607)}}{1 + e^{(0.4734 \Delta T_{\text{diff}} - 2.607)}} \quad (7)$$

(Screendump from CIBSE guideline TM 52)

With this P-equation (and the percentage of dissatisfied requirements for the different classes mentioned in row 3 of Table 1 in mind) one can determine the following:

- As long as the operative temperature indoors is not more than 1 K higher than the (outdoor temperature dependant) comfort temperature (as defined by [19] and as mentioned in Annex A2 of EN 15251 [15]), the percentage of people that is dissatisfied (that feels warm or hot and scores +2 or +3 on the 7-point ASHRAE scale of thermal sensation) is not higher than about 10% (rounded off from 10.59%);
- As long as the operative temperature indoors does not exceed the comfort temperature by more than 2 K, the percentage of people that is dissatisfied (that scores +2 or +3) is not higher than about 15% (rounded off from 15.97%);
- As long as the operative temperature indoors is not more than 3 K higher than the comfort temperature, the percentage of people that is dissatisfied (that scores +2 or +3) is not higher than about 25% (rounded off from 23.38%).

It is this P-equation that allows us to make a connection between the non-adaptive and the adaptive requirements as used in respectively EN-ISO 7730 and EN 15251. With as end result the hybrid reference limits as presented in the figures 2 till 5.

One might argue in this context that the theoretical or Predicted Percentage of Dissatisfied (PPD) as determined in lab experiments (the rationale behind the non-adaptive EN-ISO 7730 limits) is not the same as the Actual Percentage of Dissatisfied (APD) as determined during field explorations (the rationale behind the adaptive EN 15251 limits and the P-equation presented in CIBSE TM 52). Especially because of the disturbing, additional effect of local thermal discomfort (such as, draft) that normally is not corrected for when translating PDs as found in lab situations to PD's in real live situations. We decided that in this case it is not a problem to assume that PPD and APD are the same as the main issue here is overheating / thermal discomfort in summer and normally than draft and other local discomfort is less of an issue.

6 Verification guidance

The new ISSO 74 guideline also describes how one can verify in practice whether a building's thermal performance is as planned, in the design phase or during the use phase. Both in the context of regular projects and design & built (PPP/ DBFMO) projects.

It is beyond the scope of this article to describe the details of the verification chapter. We limit ourselves by just describing how simulation and long term measurements results can be presented according to the new ISSO 74. Figure 6 provides an 'output example'.

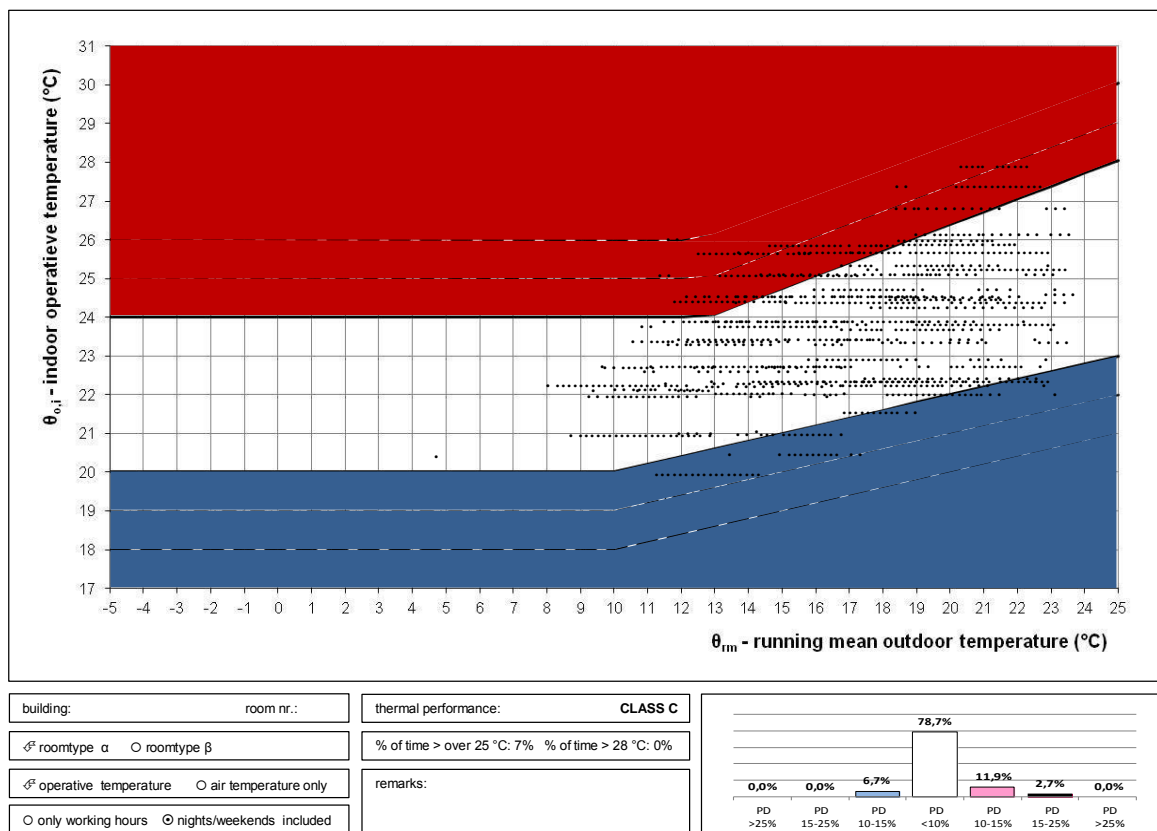

Figure 6. The ISSO 74: 2014 format for the presentation of simulation or measurement results (colors refer to anticipated average thermal sensation at different rmot - indoor temperature combinations)

Note that this graph was specifically designed so also non-technical stakeholders (decision makers) can easily understand whether a building is performing as planned (and for instance, not too warm in summer).

For more background information on the new standard and the verification chapter (all in Dutch) see [24].

7 Conclusion

The upgrade version of the ISSO 74 adaptive thermal comfort guideline differs in several way from the 2004 version:

- The new guideline generally better tunes in with the adaptive thermal comfort approach as described in Annex A2 of EN 15251; the new requirements are based on data of the SCATs database instead of on the RP 884 database;
- The guideline also gives guidance for optimal temperatures during the heating season;
- The guideline works with extra class D / category IV criteria; and it introduces a new approach for class A / category I situations (taking into account the beneficiary effects of personal control);
- The guideline integrates adaptive and non-adaptive requirements (with graphs that combine both horizontal 'Fanger upper limits' with diagonal 'Humphreys limits'). This is why the new guideline was named 'hybrid'.

So far, the new (draft version of the) guideline has been tested only for a few projects. But the first signs are promising. The 2014 version of ISSO 74 appears to be much easier to apply in practice (especially due to the new verification chapter). Therefore, we expect that the new version of the guideline will help convince professional parties involved in building and HVAC system design to more often for adaptive (hybrid) thermal comfort.

References

1. Raue AK, Kurvers SR, van der Linden AC, Boerstra AC & Plokker W, 2006. Dutch thermal comfort guidelines: from weighted temperature exceeding hours towards adaptive temperature limits. *Proceedings of conference: Comfort and Energy Use in Buildings - Getting them Right, Cumberland Lodge, Windsor, UK, 27-30th April 2006*. London: Network for Comfort and Energy Use in Buildings, see: <http://nceub.org.uk>
2. van der Linden AC, Boerstra AC, Raue AK, Kurvers SR & de Dear RJ, 2006. A new guideline in the Netherlands: A new approach for the assessment of building performance with respect to thermal indoor climate. *Energy and Buildings* 38(1):8-17
3. Nicol JF & Humphreys MA, 2009. New standards for comfort and energy use in buildings. *Building Research and Information* 37(1):68-73
4. de Dear RJ, Brager GS & Cooper D, 1997. *Developing an adaptive model of thermal comfort and preference, Final Report ASHRAE RP-884*. American Society of Heating, Refrigerating and Air-Conditioning Engineers, Atlanta, GA, USA
5. Höpfe P, 1997. Aspects of human biometeorology in past, present and future, *International Journal of Biometeorology* 34(6):661-665

6. van Hoof J, 2009. Forty years of Fanger's model of thermal comfort: comfort for all? *Indoor Air Journal* 18(3):182-201
7. Fanger PO, 1967. Calculation of thermal comfort: introduction of a basic comfort equation. *ASHRAE Transactions* 73(2): III.4.1-III.4.20.
8. Fanger PO, 1970. *Thermal comfort*. Danish Technical Press, Copenhagen, Denmark.
9. Auliciems A, 1981. Towards a psychophysiological model of thermal perception. *International Journal for Biometeorology* 25(2):109-122
10. MA Humphreys & JF Nicol, 2002. The validity of PMV for predicting comfort votes in every-day thermal environments. *Energy and Buildings* 34(6):667-684
11. Halawa E & van Hoof J, 2012. The adaptive approach to thermal comfort. A critical overview. *Energy and Buildings* 51:101-110
12. Brager GS & de Dear RJ, 1998. Thermal adaptation in the built environment: a literature review. *Energy and Buildings* 27(1):83-96
13. McCartney KJ & Nicol JF, 2002. Developing an adaptive control algorithm for Europe: Results of the SCATs Project. *Energy and Buildings* 34(6):623-635
14. ASHRAE, 2004. *ASHRAE standard 55 - Thermal environmental conditions for human occupancy*. American Society of Heating, Refrigerating and Air-Conditioning Engineers, Atlanta, GA, USA.
15. CEN, 2007. *EN 15251*. Indoor environmental input parameters for design and assessment of energy performance of buildings addressing indoor air quality, thermal environment, lighting and acoustics. CEN, Brussels, Belgium.
16. CIBSE, 2013. *CIBSE TM 52 guideline - The limits of thermal comfort: avoiding overheating in European buildings*. CIBSE Chartered Institution of Building Services Engineers, London, UK.
17. SIA, 2013. *SIA SN 180 guideline: Wärmeschutz, Feuchteschutz und Raumklima in Gebäuden*. SIA Schweizerischer Ingenieur- und Architektenverein, Zürich, Switzerland.
18. GB/T, 2012. *National Standard China GB/T 50785: Evaluation standard for indoor thermal environment in civil buildings*. Architecture and Building Press, Beijing, China.
19. Nicol F & Humphreys MA, 2010. Derivation of the adaptive equations for thermal comfort in free-running buildings in European standard EN 15251. *Building and Environment* 45(1):11-17
20. CEN, 2005. *EN-ISO 7730. Ergonomics of the thermal environment - Analytical determination and interpretation of thermal comfort using calculation of the PMV and PPD indices and local thermal comfort criteria*. CEN, Brussels, Belgium
21. FiSIAQ, 2008. *Finnish classification of indoor climate. Finnish Society of Indoor Air Quality and climate 2008*, Helsinki, Finland
22. Arens E, Humphreys MA, de Dear R & Zhang H, 2010. Are 'Class A' temperature requirements realistic or desirable? *Building and Environment* 45(1):4-10
23. Olesen BW, 2000. Guidelines for Comfort. *ASHRAE journal* 8: 40-45.
24. ISSO, 2014. *ISSO publicatie 74 (in Dutch). Thermische behaaglijkheid. Eisen en achtergronden betreffende het thermisch binnenklimaat in kantoren, scholen en vergelijkbare utiliteitsbouw*. ISSO, Rotterdam, the Netherlands.

Application of the adaptive model proposed by ASHRAE 55 in the Brazilian climate context: raising some issues

**Renata De Vecchi^{1*}, Márcio J. Sorgato¹, Miguel Pacheco¹, Christhina Cândido² and
Roberto Lamberts¹**

1 Federal University of Santa Catarina, Department of Civil Engineering – Brazil;

2 The University of Sydney, Faculty of Architecture, Design and Planning – Australia;

* Corresponding email: renata.vecchi@labeee.ufsc.br

Abstract

This paper evaluates the adaptive method application proposed by the last version of ASHRAE 55 (2013) standard in two different climates in Brazil. ASHRAE 55 (2013) currently allows for linear and exponential methods to calculate the prevailing mean outdoor air temperature ($T_{pma(out)}$) and both are used to establish the acceptability zones. For the exponential method, two different α were used (0.6 and 0.8). Moreover, the $T_{pma(out)}$ was calculated for two different time spans (7 and 30 days). Results indicate that choosing linear or exponential, and even a monthly method, to calculate the $T_{pma(out)}$ is indifferent when small amplitudes are concerned; but it can lead to different limits of acceptability when significant day to day temperature variations are present. However, the impact on the sum of discomfort hours is minimal. In addition, the results of this paper indicates that it is possible to find significant percentages of thermal acceptability from previous field study below the lower limit of acceptability proposed by the ASHRAE 55 (2013) adaptive model. Thus, a clo adjustment zone is suggested.

Keywords: thermal comfort, ASHRAE 55 adaptive model, prevailing mean outdoor air temperature, clo adjustment zone.

Introduction

In the last 3 decades, many questions regarding the applicability of Fanger's (1970) thermal comfort model in buildings with reduced energy use through passive conditioning resulted in the rise of a different model, extensively known as adaptive model (de Dear et al., 1997; Brager and de Dear, 1998; Nicol et al., 2012). Since then, the adaptive concept has been incorporated in the main thermal comfort standards, as ASHRAE 55 Standard (subsequently the 2004 version), ISO 7730 (subsequently the 2005 version) and EN 15251 (subsequently the 2007 version). Among the outlined standards, ISO 7730 remains with a superficial version of the adaptive concept with no updates since then, while others adopted the model based in extensive field results. The European standard EN 15251 (2007) is based on results of the European Union project Smart Controls and Thermal Comfort (SCATs), which aimed to reduce energy consumption in air conditioning systems by adjusting the building's internal temperature in line with outdoor temperatures through an adaptive algorithm (Nicol and Humphreys, 2010). ASHRAE 55 (2013) is based on the results of ASHRAE RP-884, which

analysed a dataset with global and climatic variability, containing over twenty thousand entries of the indoor microclimate and the occupant’s sensation, preference and acceptability (de Dear et al., 1997). In Brazil, the thermal comfort standards are outdated, and no mention about the adaptive model is found. However, Lamberts et al. (2013) published a research report that present a Brazilian Standard proposal, written based on ASHRAE 55 (2010). At moment, NBR 16401 (ABNT 2008) that deals with HVAC design is under revisions, and the proposed standard was sent to the committee.

ASHRAE 55 is a widely adopted standard to assess thermal comfort in buildings, and this fact occurs mainly due to the constant updates and revisions of the document, reflecting the newest results from field experiments in thermal comfort area. In its current version, ASHRAE 55 (2013) presents two graphical methods: one for thermal comfort evaluation in all spaces where average air speed do not exceed 0.2 m/s (Figure 1); and another one is specifically for naturally ventilated environments (Figure 2). The main modification from last published version related to naturally ventilated environments is the adoption of a prevailing mean outdoor air temperature ($T_{pma(out)}$), calculated by an average of the immediate previous days (starting with yesterday, the day before yesterday and continuing backwards until the last day of the chosen time span). To establish a comfort zone of a specific day considering 80% of acceptability, 3.5°C are added and subtracted to the prevailing mean outdoor air temperature.

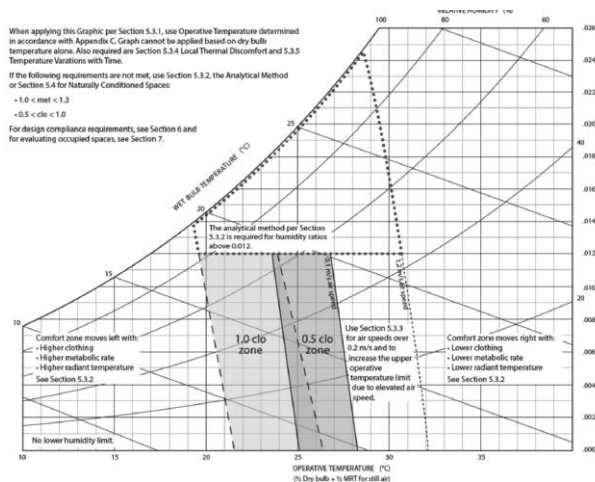

Figure 1. Graphic comfort zone method for determining acceptable thermal conditions in spaces with low air speed. Source: ASHRAE 55 (2013).

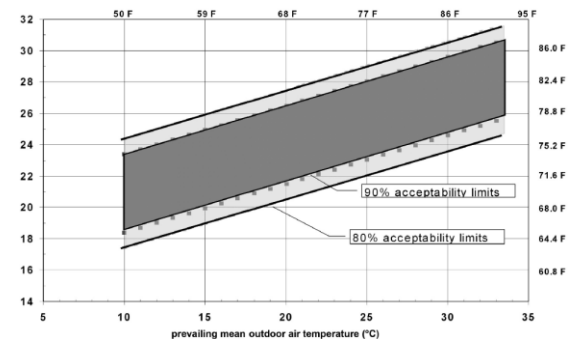

Figure 2. Acceptable operative temperature ranges for naturally conditioned spaces. Source: ASHRAE 55 (2013)

The prevailing mean outdoor air temperature is an essential parameter to assess the thermal comfort condition based in the adaptive model; in the last revision, ASHRAE 55 (2013) presented a method that let the users freely select the best calculation form, which differ in calculation process of the prevailing mean temperature and in the time span chosen. It can be determined by the use of a simple arithmetic average (which can be obtained by a range of averages considering at minimum 7 and maximum 30 days prior to the day in question) and, as an exception, it is also possible to use an exponential weighted average. When the weather

data to calculate the prevailing mean temperature are not available, the standard permit the use of published meteorological monthly mean temperature. The difference between the two equations proposed involves the weighting of immediate previous days: the simple arithmetic average weights all days equal, while the exponential average weight the days closer to the reference day, according with the α value set (which can vary from 0.6 to 0.9).

Since the prevailing mean outdoor air temperature was incorporated in adaptive model of ASHRAE 55 (since addenda C from ASHRAE 55/2010), few studies evaluated the applicability of this method in the Brazilian context. Lamberts et al. (2013) analysed a series of thermal acceptability votes from Brazilian field experiments in different climates, noticing some discrepancies related to the model. According with the authors, the adaptive opportunities played a major role in these thermal environments, particularly by clothing adjustments (blue dots) and the air speed value (orange dots). The new version of ASHRAE 55 (2013) incorporated an increase in the upper acceptability limit related to air speed, but the lower limit remains as an issue not discussed yet. In this context, this paper focuses specifically on ASHRAE 55 (2013) adaptive model application in Brazilian climatic conditions

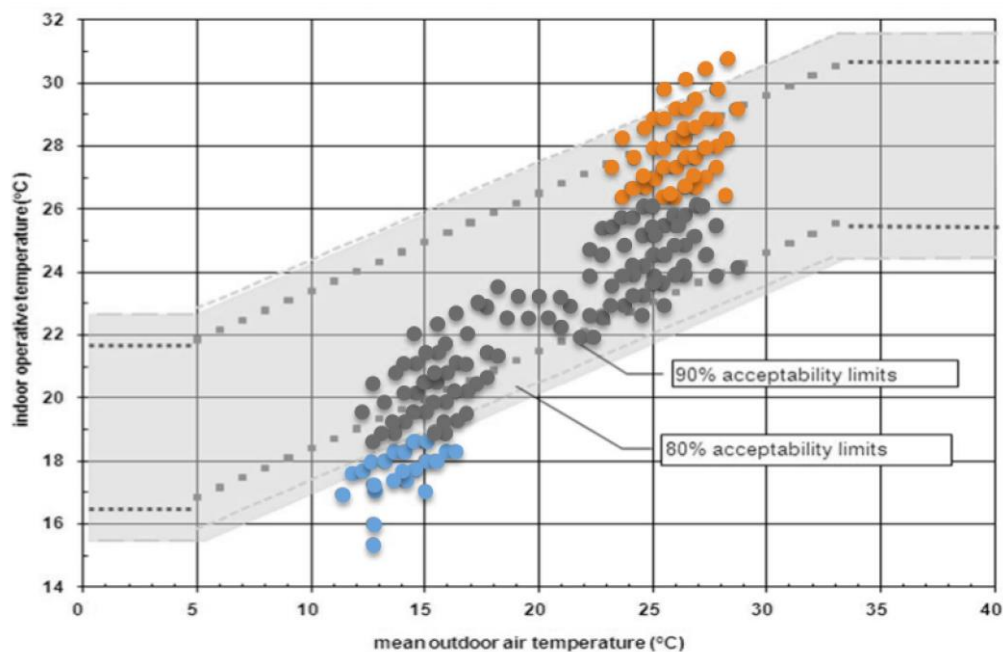

Figure 3. Thermal acceptability for naturally ventilated buildings with Brazilian field data.
Source: Lamberts et al., 2013.

Method

This study is mainly based in the application of ASHRAE 55 (2013) adaptive model in two Brazilian cities with different climatic conditions. The results were used to compare all the prevailing mean outdoor air temperature calculation methods, considering the number of hours in which environmental conditions are outside the comfort zone (cold and hot discomfort). Furthermore, data from field experiments carried out in one of the analysed cities was used to verify the applicability of the adaptive graph from ASHRAE 55 (2013).

Climates description

According with the Köppen-Geiger (Peel et al., 2007) climatic classification, the Brazilian territory has eight climates variations with different features. In this paper, a city from the North and a city from the South were chosen (Figure 4).

Florianópolis is an island located on the south of Brazil (latitude 27°40'S; altitude 7m), classified as a humid subtropical climate. The city presents humid and rainy summers due to unstable air masses, and mild winters. Relative humidity is high throughout the year (about 82%) and there is no dry season. The highest rainfall occurs from October to March and the lowest from July to August (mean annual precipitation is 1521mm). **Belém**, located in North of Brazil, has a tropical rainforest climate (latitude -1°40'S and altitude 16m), and is a city that suffers a direct influence of the Amazon rain forest. For this reason, the rainfalls are constants (mean annual precipitation is 2889mm) and the humid seasons noticeably, spanning from December through May. The others months present a small reduction in precipitation volume. Average temperatures have no significant variations throughout the year, presenting an annual mean temperature around 26.5°C.



Figure 4. Brazilian's climatic classification according with Peel et al. (2007) and location of selected cities.

Data evaluation and the thermal acceptability limits of each climate were set by weather files in TRY format (Test Reference Year - TRY). The files were obtained from a climatic database of a typical year, available for download at the Laboratory of Energy Efficiency in Buildings (LabEEE)¹ electronic address.

¹ <http://www.labeee.ufsc.br/downloads/arquivos-climaticos/formato-try-swera-csv-bin>

Prevailing mean outdoor air temperature

The prevailing mean outdoor air temperature ($T_{pma(out)}$) was determined according with the three ASHRAE 55 (2013) methods:

- **Method 1:** A simple arithmetic mean of all mean daily outdoor air temperatures ($t_{mda(out)}$), calculated with 7 and 30 sequential days prior to the day in question.
- **Method 2:** The weighting method in which the exponential value (α) were set in 0.6 and 0.8. In this method, twenty sequential days before the day in question were used to avoid residual losses.

The exponentially equation used from ASHRAE 55 (2013) is the following:

$$\overline{t_{pma(out)}} = (1 - \alpha)[t_{e(d-1)} + \alpha t_{e(d-2)} + \alpha^2 t_{e(d-3)} + \alpha^3 t_{e(d-4)} + \dots] \quad (1)$$

Note: In the “ $\alpha^2 t_{e(d-3)}$ ” part of ASHRAE’s 55 equation, there is an "a" instead the " α ", which the authors considered as a typing error and replaced according.

- **Method 3:** The published meteorological monthly means for each calendar month.

Adaptive model acceptability limits

The acceptability limits were determined according with the equations from ASHRAE 55 (2013) considering the 80% acceptability limits (Equations 2 and 3). To determine the 90% limits, 1°C were subtracted from each limit

- Upper 80% acceptability limit (°C): $0.31 \overline{t_{pma(out)}} + 21.3$ (2)
- Lower 80% acceptability limit (°C): $0.31 \overline{t_{pma(out)}} + 14.3$ (3)

Field experiments

The thermal comfort votes used to verify the applicability of adaptive graph from ASHRAE 55 (2013) were carried out by De Vecchi 2011 and results from thermal history and cooling preference in HVAC were published by De Vecchi et al. (2012). The field experiment was conducted in Florianópolis in 2010 collecting a total of 2.292 votes. The data were separated in two groups: data with air-conditioning use (n = 1.200) and data without air-conditioning use (n = 1092). For the purpose of this paper, only the acceptability votes from the group where no air-conditioning was used were selected (n = 920, 84% of 1.092 votes). During the experiment, the air speed average was approximately 0.6 m/s, and this value was considered to adjust the acceptability upper limit related to the air speed value, as ASHRAE 55 (2013) determined.

Hours of comfort quantification

The comparison was performed by quantifying the discomfort hours considering the acceptability limits delineated by ASHRAE 55 (2013). Thus, the authors assumed a hypothetical situation where the building indoor operative temperature is exactly the same of outdoor air temperature, ignoring the internal loads and assuming good natural ventilation

throughout the year. In Belém's quantification - where the annual higher temperatures are favourable to natural ventilation – all the months were considered. In Florianópolis, only the summer months were considered (from December 21st to March 20st), focusing in the periods in which the buildings can be operated predominantly with natural ventilation.

ASHRAE 55 (2013) allows the quantification of the number of hours in which environmental conditions are outside the comfort zone requirements for adaptive model during the occupied hours in the time period of interest (Exceedance Hours – EH method). To this end, the following calculation from ASHRAE 55 (2013) was used:

$$EH = \Sigma (H_{>upper} + H_{<lower}) \quad (4)$$

Where: $H_{>upper} = 1$ if $T_{op} > t_{upper}$ and 0 otherwise, and
 $H_{<lower} = 1$ if $T_{op} < t_{lower}$ and 0 otherwise;

$H_{>upper}$ and $H_{<lower}$ are the discomfort hours outside the zone boundaries and the units are in hours. Although, the method proposed on the standard only quantify the total of discomfort hours, which were separated by cold discomfort hours (the $H_{<lower\ limit}$ values) and hot discomfort hours (the $H_{>upper\ limit}$ values) by the authors. The occupation period considered in this paper in the daytime is from 7am to 7pm (commercial buildings) and in the night-time from 7pm to 7am (residential buildings).

Results and Discussion

Initially, the prevailing mean outdoor air temperature was calculated from all methods described and for each of the analysed climates. Figure 5 and Figure 6 show the differences between the prevailing mean outdoor air temperatures calculated by the arithmetic average considering the last 7 and 30 days prior to the day in question, the exponentially weighted running mean temperature with α set to 0.6 and 0.8 and the monthly means for each calendar month. Analysing Figure 5, it is observed that the exponentially weighted and arithmetic (considering 7 days) methods showed similar results, reproducing the outdoor air temperature behaviour. Among then, the line with α set at 0.6 is the one that is closest to the outdoor air temperature, providing a prevailing mean temperature with a faster response for the last recent days. In Belém, where no significant variation in external temperature are observed throughout the year, all the methods results in similar values of prevailing mean temperature (Figure 6).

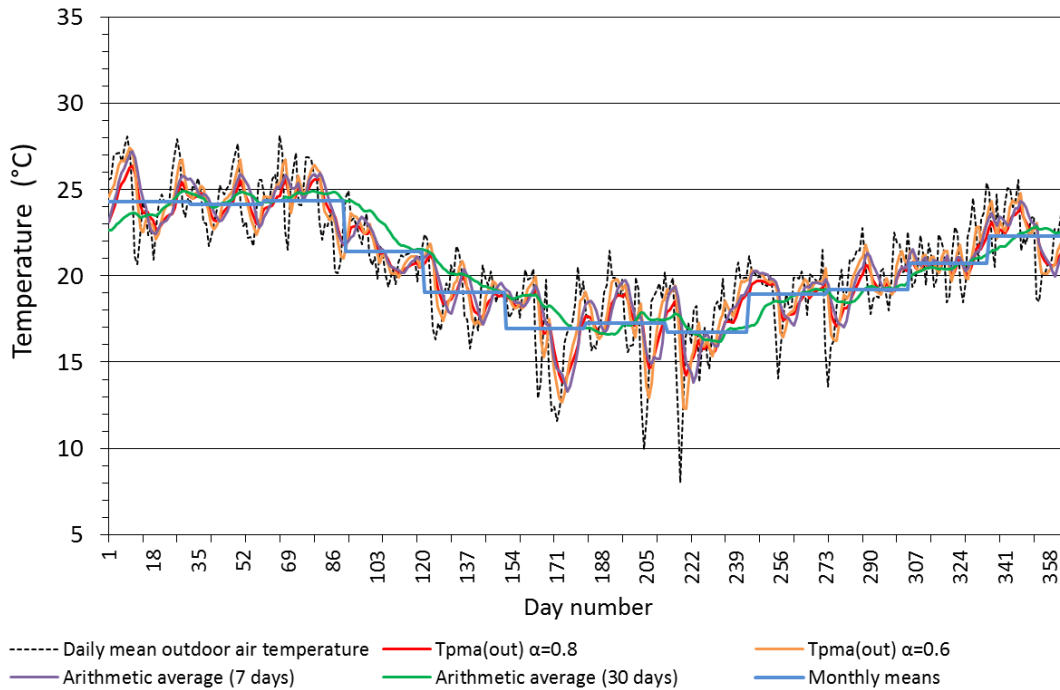

Figure 5. Prevailing mean outdoor air temperature from Florianópolis's climate.

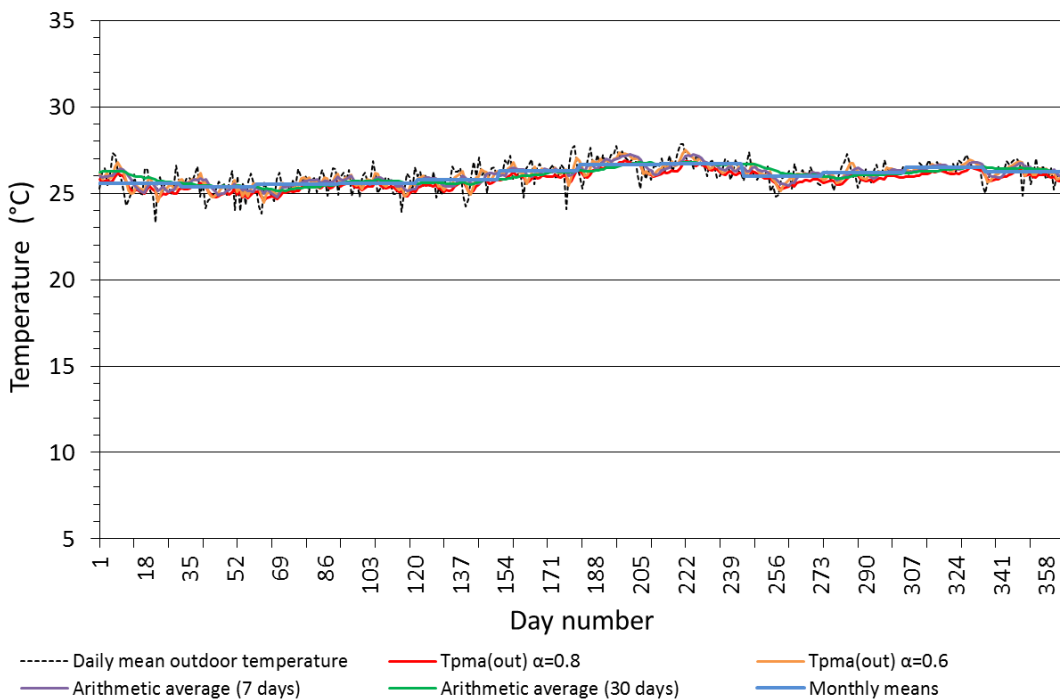
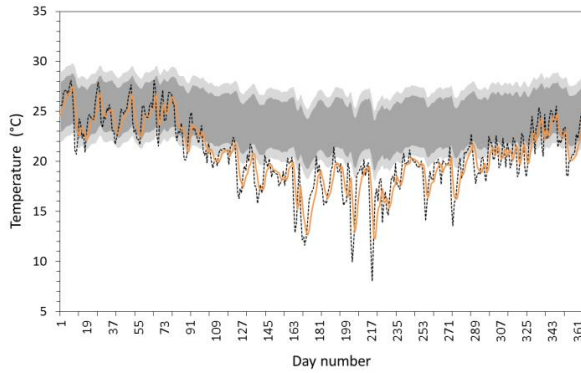

Figure 6. Prevailing mean outdoor air temperature from Belém's climate.

The prevailing mean outdoor air temperature impacts directly in the lower and upper limit of acceptability zone, and such results can be observed in Figure 7. The range represented by the darker color characterizes 90% acceptability and the light color range 80% acceptability. When the acceptability zone is defined from exponential method (α 0.6) it is possible to observe a greater oscillation in the upper and lower zone limits, which followed the external

temperature fluctuations (Figure 7a). When α was set to 0.8, these oscillation are smaller, but still visible. A similar small oscillation was observed in Figure 7c, when the zone boundaries were calculated from arithmetic average considering the previous 7 days. The arithmetic average which considered the last 30 day showed a smooth variation throughout the year (Figure 7d), and the monthly means showed an acceptability zone with monthly steps (Figure 7e).



a) Florianópolis, α 0.6

90% acceptability
 80% acceptability
 Mean daily outdoor air temperature
 Tpma(out) $\alpha=0.6$

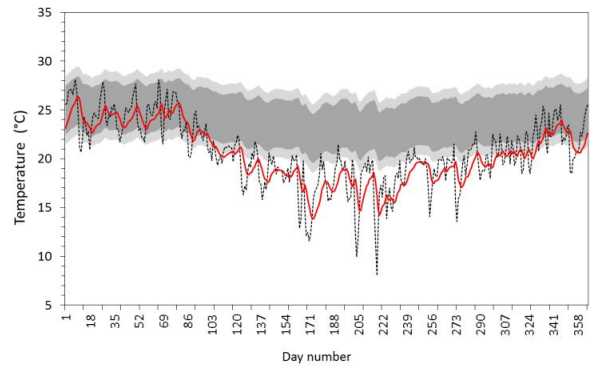

b) Florianópolis, α 0.8

90% acceptability
 80% acceptability
 Mean daily outdoor temperature
 Tpma(out) $\alpha=0.8$

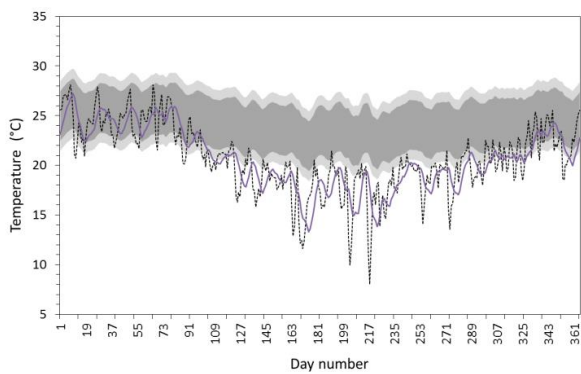

c) Florianópolis, 7 days average

90% acceptability
 80% acceptability
 Daily mean outdoor air temperature
 Arithmetic average (7 days)

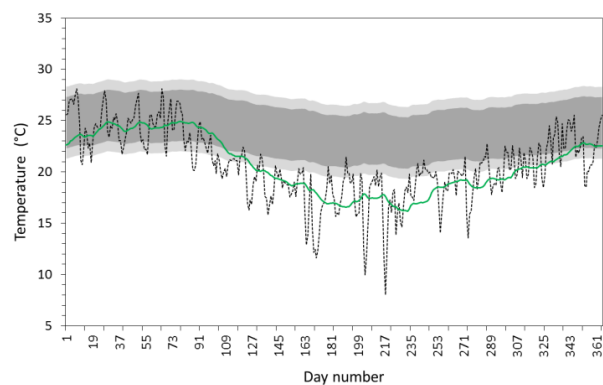

d) Florianópolis, 30 days average

90% acceptability
 80% acceptability
 Daily mean outdoor air temperature
 Arithmetic average (30 days)

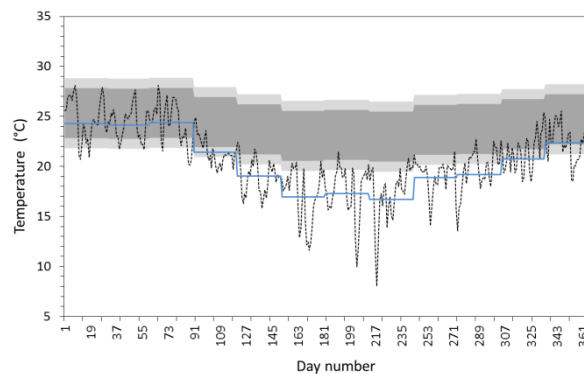

e) Florianópolis, monthly means

90% acceptability
 80% acceptability
 Daily mean outdoor air temperature
 Monthly means

Figure 7. Adaptive comfort zone defined as a function of the prevailing mean outdoor air temperature.

The results found in Florianópolis and Belém were plotted in the adaptive comfort graph assuming that the indoor operative temperature is exactly the same of external air temperature. The prevailing mean outdoor air temperature was calculated with the exponential weighted method and α set to 0.6. Figure 8 shows the results considering only the commercial hours in both cities for the warm months (between December 21st and March 20st) in Florianópolis, and all the year in Belém. From Figure 8b, it is possible to observe points that characterize a cold discomfort situation when the prevailing mean temperature is superior to 25°C and the indoor operative temperature superior to 22°C. Florianópolis presents a similar situation, but with a lower number of points in this zone.

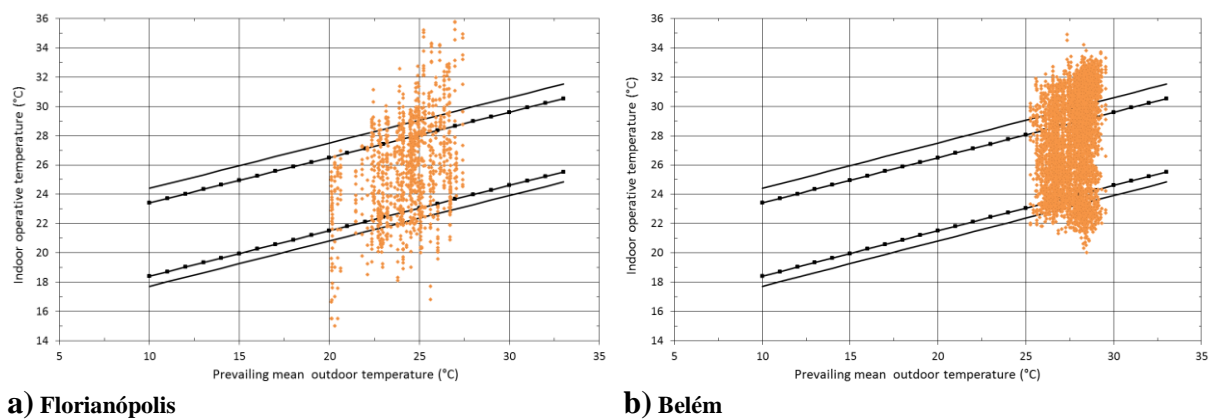

Figure 8. Cities climate data plotted in the adaptive graph from ASHRAE 55 (2013).

The thermal comfort votes used in this study to verify the applicability of adaptive graph is shown on Figure 9. The acceptability votes represent 84% from 1092 analysed data; when plotted in Figure 9 graph, there is a small number of votes that exceed the upper limit (3% of the votes considering the same prevailing mean temperature conditions), and a significant number that exceed the lower limit (24% of the votes considering the same prevailing mean temperature conditions). However, when air speed is significant the Standard proposed an adjustment to the upper limit fixed in 1.2°C when the average air speed is 0.6 m/s, while the votes below the lower limit are characterized as cold discomfort. In situations like these one, these votes can be explained by the garment adjustment (clo), and such results have also been observed in Lamberts et al. (2013). Thus, Figure 9 also proposes an adjustment to these votes based on the clo adaptation (orange zone), and based in the lower limit of the 1.0 clo zone proposed by the graph method for environments with low air velocity, set in 19.5°C for 80% of R.H (seen Figure 1).

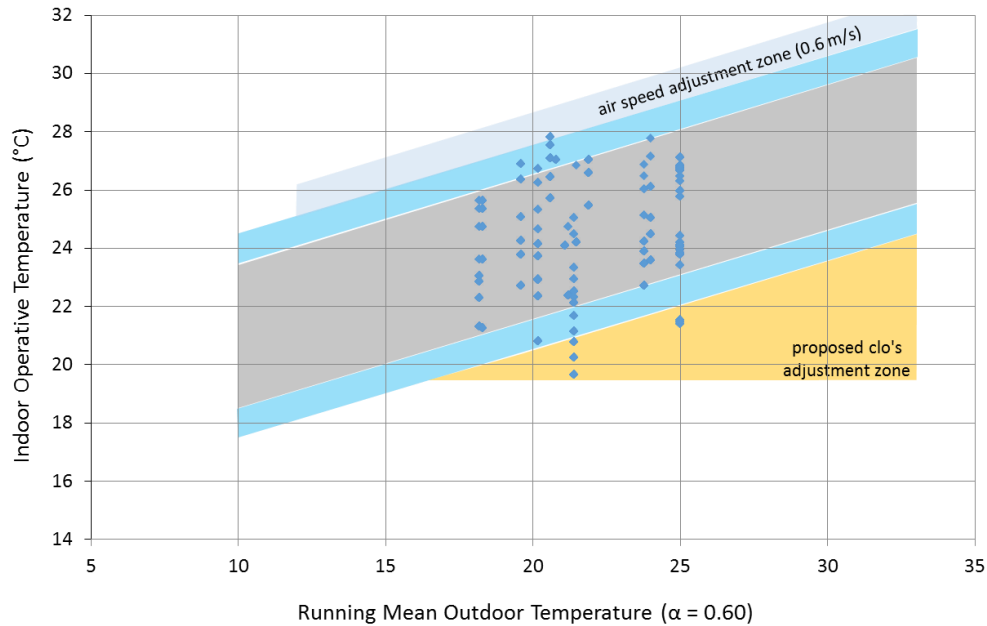

Figure 9. Thermal acceptability votes from the experiment of De Vecchi (2011) plotted on the acceptable operative temperature zone for naturally conditioned spaces and the proposed zone for the clo adjustment.

The discomfort hours was quantified by the number of exceedance hours in which environmental conditions are outside the comfort zone during the occupation time (daytime and night-time). These analyses were made to all the calculations forms of the prevailing mean temperature, and the hours were separated by cold discomfort, and hot discomfort (Tables 1 and 2) Table 1 presents the results of Florianópolis considering the hours of the warm months. Table 2 presents the results of Belém city considering all the hours from a full year.

Table 1. Data quantification to Florianópolis city (daytime and night-time).

Daytime Period (7am - 7pm)	α 0.6	α 0.8	7 days	30 days	Monthly
$H_{<lower}$ (Cold discomfort/hours)	114	116	131	104	104
$H_{>upper}$ (Hot discomfort/hours)	214	195	205	234	211
% of hours outside the acceptability zone	28.0%	26.6%	28.7%	28.9%	27.0%
% of hours inside the acceptability zone	72.0%	73.4%	71.3%	71.1%	73.0%
Total hours analysed	1170	1170	1170	1170	1170
Night-time Period (7pm – 7am)	α 0.6	α 0.8	7 days	30 days	Monthly
$H_{<lower}$ (Cold discomfort/hours)	253	256	265	233	233
$H_{>upper}$ (Hot discomfort/hours)	0	0	0	0	0
% of hours outside the acceptability zone	25.6%	25.9%	26.8%	23.5%	23.5%
% of hours inside the acceptability zone	74.4%	74.1%	73.2%	76.5%	76.5%
Total (hours)	990	990	990	990	990

In Florianópolis, the difference between the exceedance hours resulted in values with no significant differences in both periods analysed (daytime and night-time). In night-time quantification, the arithmetic 30 days mean presented the larger number of discomfort hours, value 3.3% superior of the lowest one in the 30 days average and monthly means. Conversely in Belém, the arithmetic average considering the 30 days and the monthly mean were the ones that resulted in the smaller number of cold discomfort when compared to Florianópolis. The difference between values from these two methods in the cold discomfort hours was about 7% during night-time.

Table 2. Data quantification to Belém city (daytime and night-time).

Daytime Period (7am - 7pm)	α 0.6	α 0.8	7 days	30 days	Monthly
$H_{<lower}$ (Cold discomfort - hours)	286	315	317	118	118
$H_{>upper}$ (Hot discomfort - hours)	1487	1408	1404	1861	1795
% of hours outside the acceptability zone	37.4%	36.3%	36.3%	41.7%	40.3%
% of hours inside the acceptability zone	62.6%	63.7%	63.7%	58.3%	59.7%
Total (hours)	4745	4745	4745	4745	4745
Night-time Period (7pm – 7am)	α 0.6	α 0.8	7 days	30 days	Monthly
$H_{<lower}$ (Cold discomfort - hours)	47	101	114	157	157
$H_{>upper}$ (Hot discomfort - hours)	301	322	328	5	9
% of hours outside the acceptability zone	8.7%	10.6%	11.0%	4.0%	4.1%
% of hours inside the acceptability zone	91.3%	89.4%	89.0%	96.0%	95.9%
Total (hours)	4015	4015	4015	4015	4015

If used to the exceedance hours calculations, the proposed clo's adjustment zone from Figure 9 eliminate all the cold discomfort throughout the year in Belém (considering all the 24 hours of occupation); and, in Florianópolis, the cold discomfort hours drops 72% (244 hours), considering data from 30 day column and 24 hours of occupation.

Conclusions

This paper presented the application of adaptive method from ASHRAE 55 (2013) in the Brazilian climate context. Some previous results raised a series of issues, which led to a deeper analysis in two different climates: an island located in the South of Brazil (Florianópolis) classified as a humid subtropical climate and a tropical rainforest climate located in North (Belém), with an annual mean temperature around 26.5°C. Thus, the following topics were discussed: 1) the different methods to calculate the prevailing mean outdoor air temperature, their results and implications on ASHRAE 55 (2013) acceptability zone; 2) the lower limit from ASHRAE's adaptive graph and the adjustment suggested based on the clo adaptation.

As a general comment, the exponentially weighted equation with α set to 0.6 is the method with a faster response to the recent days; however, when the sums of hours quantification is compared considering the monthly means method, no significant differences were found (2.1% of difference in discomfort hours between the two methods in Florianópolis). Choosing a linear or exponential method to calculate the prevailing mean outdoor air temperature is indifferent when small amplitudes are concerned; but it can lead to different limits of acceptability when significant day to day temperature variations are present. However, even with these zones displacements, the impact on the sum of discomfort hours is minimal. The exponential method, regardless of the strong relation with the external air temperature, is more laborious to be applied by the users of the Standard.

Also, the results indicated that it is possible to find significant percentages of thermal acceptability data below the lower limit of the zone proposed by the ASHRAE 55 (2013) adaptive model. Thus, an adjustment in the lower limit of 80% acceptability was proposed considering that before the occupant use any other form of adaptation, the first thing they will adapt is the garment. This adaptation occurs instinctively, explaining the votes of acceptability outside the lower limit. Based on the results of this paper, the proposed clo's adjustment zone can eliminate more than 70% of discomfort data in warm months in Florianópolis, and 100% of discomfort data from Belém throughout the year. The lower limit of the acceptability zone from adaptive model represents a contradiction if compared to the lower limit stipulated by the graphic comfort zone to spaces with low air speed. In this graphic, the indoor operative range occur between 19.5°C and 26.5°C to 1.0 clo and between 25°C and 28°C to 0.5 clo.

References

- ABNT, 2008. *Instalações de ar-condicionado - Sistemas centrais e unitários - Parte 2: Parâmetros de conforto térmico, NBR 16401-2*, Rio de Janeiro: Associação Brasileira de Normas Técnicas.
- ASHRAE Standard 55, 2010. *Thermal Environmental Conditions for Human Occupancy*, Atlanta, Georgia: American Society of Heating, Refrigerating and Air-Conditioning Engineers.
- ASHRAE Standard 55, 2013. *Thermal environmental conditions for human occupancy*, Atlanta, Georgia: American Society of Heating Refrigerating and Air-Conditioning Engineers.
- Brager, G. & de Dear, R., 1998. Thermal adaptation in the built environment: a literature review. *Energy and Buildings*, 27(1), pp.83–96.
- De Dear, R., Brager, G. & Cooper, D., 1997. *Developing an adaptive model of thermal comfort and preference: Final Report on ASHRAE RP - 884*, Sydney: MRL.

- De Vecchi, R., 2011. *Condições de conforto térmico e aceitabilidade da velocidade do ar em salas de aula com ventiladores de teto para o clima de Florianópolis/SC*, Dissertação de Mestrado. Departamento de Engenharia Civil, Universidade Federal de Santa Catarina. Florianópolis, 2011.
- De Vecchi, R., Cândido, C. & Lamberts, R., 2012. Thermal history and its influence on occupants' thermal acceptability and cooling preferences in warm-humid climates: a new desire for comfort? In *Proceedings of the 7th Windsor Conference: The changing context of comfort in an unpredictable world*. Cumberland Lodge, London UK.
- EN 15251, 2007. *Indoor environmental input parameters for design and assessment of energy performance of buildings - addressing indoor air quality, thermal environment, lighting and acoustics*, Brussels: CSN.
- Fanger, P.O., 1970. *Thermal comfort - analysis and applications in environmental engineering*, Copenhagen: Darlish Technical Press.
- Lamberts, R., Cândido, C., de Dear, R. & De Vecchi, R., 2013. Towards a brazilian standard on thermal comfort., p.122. Available at:
http://www.labeee.ufsc.br/sites/default/files/publicacoes/relatorios_pesquisa/RP_Towards_a_Brazilian_Standard_Complete_Version2013.pdf.
- Nicol, F. & Humphreys, M., 2010. Derivation of the equations for comfort in free-running buildings in CEN Standard EN15251, Special Issue Section: International Symposium on the Interaction Human and Building Environment. *Building and Environment*, 45(1), pp.11–17.
- Nicol, F., Humphreys, M. & Roaf, S., 2012. *Adaptive thermal comfort: principles and practice*, Oxon – London: Routledge.
- Peel, M.C., Finlayson, B.L. & McMahon, T.A., 2007. Updated world map of the Koppen-Geiger climate classification. *Hydrology and Earth System Sciences*, 11, pp.1633–1644.

WINDSOR CONFERENCE 2014

COUNTING THE COST OF COMFORT

SESSION 7

Thermal comfort, productivity and occupant behaviour

Invited Chairs: Olli Seppänen and Noriko Umemiya

Robust Design for high workers' performance and low absenteeism – An alternative approach

Joe L. Leyten¹, **Arjen K. Raue**², **Stanley R. Kurvers**³

¹ Utrecht, The Netherlands, [mailto: joeleijten@planet.nl](mailto:joeleijten@planet.nl)

² Utrecht University, The Netherlands

³ Delft University of Technology, Faculty of Architecture, Delft, The Netherlands

Abstract

Rehva Guide No 6 – Indoor Climate and Productivity in Offices - states as its main purpose to establish quantitative relationships of indoor environmental aspects with performance and sickness absenteeism. The following relationships were established: temperature with performance, ventilation with performance, perceived indoor air quality with performance and ventilation with sickness absenteeism. The purpose of this paper is to establish what in practice are, or probably are, the most effective measures to increase performance and decrease absenteeism, given the total of the presently available evidence. We argue that robust measures, like avoidance of indoor air pollution sources, minimizing external and internal heat load, thermal effective building mass, cellular office layout with shallow plan depth, occupant control of temperature, operable windows and providing for adaptive thermal comfort are more effective in increasing performance and reducing absenteeism than less robust measures like diluting indoor air pollution through increased ventilation, controlling temperature through mechanical cooling and open plan workroom layout combined with deep plan depth.

Keywords: Workers' performance, sickness absenteeism, adaptive thermal comfort, indoor air quality, building robustness.

1 Introduction

In 2006 the Federation of European Heating and Air-conditioning Associations Rehva published Rehva Guide No 6 – Indoor Climate and Productivity in Offices – How to integrate productivity in life-cycle cost analysis of building services (from hereon: the Rehva Guide). The Rehva Guide states as its main purpose to establish quantitative relationships of indoor environmental aspects with performance and sickness absenteeism. The following relationships were established: temperature with performance, ventilation with performance, perceived indoor air quality with performance and ventilation with sickness absenteeism. The purpose of this paper is to establish what in practice are, or probably are, the most effective measures to increase performance and decrease absenteeism, given the total of the presently available evidence.

2 Temperature and performance

The impact of temperature and thermal sensation on building occupant performance has been reviewed extensively in Leyten, Kurvers and Raue (2012). The most important results are:

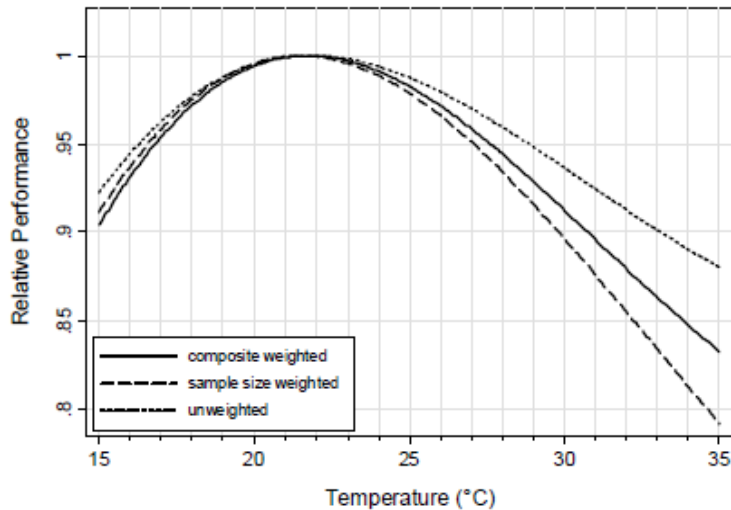

Figure 1. Relative performance vs. temperature according to Rehva Guideline No 6. Maximum performance is set equal to 1. Source: Seppänen et al. (2006a).

- The Rehva Guide presents a relation of performance with temperature based on a meta-analysis of 24 studies concerning objectively measured performance. Figure 1 shows the results of the meta-analysis. According to the figure performance is maximal at 21.75°C. Above and below this temperature performance decreases. The Rehva Guide states that the effect shown in figure 1 is statistically significant only below 20°C and above 24°C, so the temperature range of maximal performance roughly coincides with the comfort temperature for air-conditioned environments. However, none of the 24 studies concerns a free running naturally ventilated (from hereon: free running) office environment. In almost all of these studies the major mechanisms by which occupants in free running environments accept higher temperatures and feel neutral at higher temperatures in warmer climates and during the summer period in moderate climates, are prevented from working or strongly impeded. Therefore the relationship presented in the Rehva Guide cannot be extrapolated to free running environments.
- In free running environments we expect maximal performance at the matching comfort temperature, which can be considerably higher than 21.75°C.
- When it comes to comparing air conditioned environments at the matching comfort temperature and free running environments at the matching comfort temperature, we expect performance to be higher in free running environments because therein occupant satisfaction with the indoor environment will be higher and Building Related Symptoms (from hereon: BRS), including fatigue, headache and problems concentrating, will be less.

3 Ventilation rate and performance

The Rehva Guide gives a relation between ventilation rate and performance based on five field studies in offices and two laboratory studies. The results are shown in figure 2 with 6,5 l/s*person and 10 l/s*person as reference values. If the curves weighted by sample size and outcome relevance are selected performance increases 1% when ventilation rate is increased from 6.5 to 10 l/s*person and increases another 1% when ventilation rate is increased from 10 to 17 l/s*person. Seppänen et al. (2006b) states that performance increases statistically significantly in the ventilation range of 6.5 to 17 l/s*p with 90% confidence interval (from hereon: CI) and up to 15 l/s*p with 95%

CI. Even if we leniently choose the 90% CI, there is no statistically significant effect above 17 l/s*p, which implies that the maximum performance gain that can be reached by increasing the ventilation rate above 10 l/s*p is 1%.

4 Alternatives to increasing ventilation rate

The Rehva Guide also includes results of studies into the effect of different indoor air pollution sources on performance:

- Removal of used soiled carpet: 6.5% performance gain.
- Removal of relatively new CRT monitors: 9% performance gain.
- Replacing used air intake filters for new ones: 10% performance gain.

The Rehva Guide gives two relations of performance with percentage dissatisfied with air quality, respectively 0.8% and 1.1% performance gain for each 10% less dissatisfied with indoor air quality. Since these relations are based on slightly different, partly overlapping data, we propose a simplified relation of 1% performance gain for each 10% less dissatisfied with indoor air quality. This relation implies additivity of the effect of pollution sources. When it comes to the indoor air pollution caused by building materials Knudsen and Wargocki (2010) show that perceived air quality in workrooms can be improved by replacing a high polluting material by a low polluting material. The effect was most pronounced when the most polluting material was replaced by a less polluting material. This improvement was more pronounced than that achieved by a realistic increase of outdoor supply air. For the high polluting materials it was seen that, even at the highest ventilation rate at 6.4h^{-1} , it was far from possible to achieve an acceptable level of perceived air quality. The main conclusion of Knudsen and Wargocki (2010) is that the use of low polluting materials reduces the ventilation rate required to achieve an acceptable level of perceived air quality and thereby prevents unnecessary use of energy for ventilation. Improved perceived air quality implies a lower percentage dissatisfied with air quality and thereby higher performance. The effect of the removal of relatively new CRT monitors, although hardly used anymore nowadays, suggests that the emission of other office machines may also reduce performance and that they should either be selected for low emission or placed in separate rooms with dedicated ventilation. Fitzner (2000) shows that pollution source strength from other HVAC components of HVAC systems, e.g. cooling sections, air humidifiers and rotary heat exchangers is comparable with that of air intake filters. Bluysen et al. (2003) elaborate on how to avoid pollution sources in the HVAC system. All in all it is safe to expect that a strict avoidance of indoor air pollution sources in both HVAC systems and workrooms will result in a performance gain much higher than achievable by increasing ventilation. Given the percentages mentioned above a combined performance gain of 10% or more is expected, when compared to conventional practice.

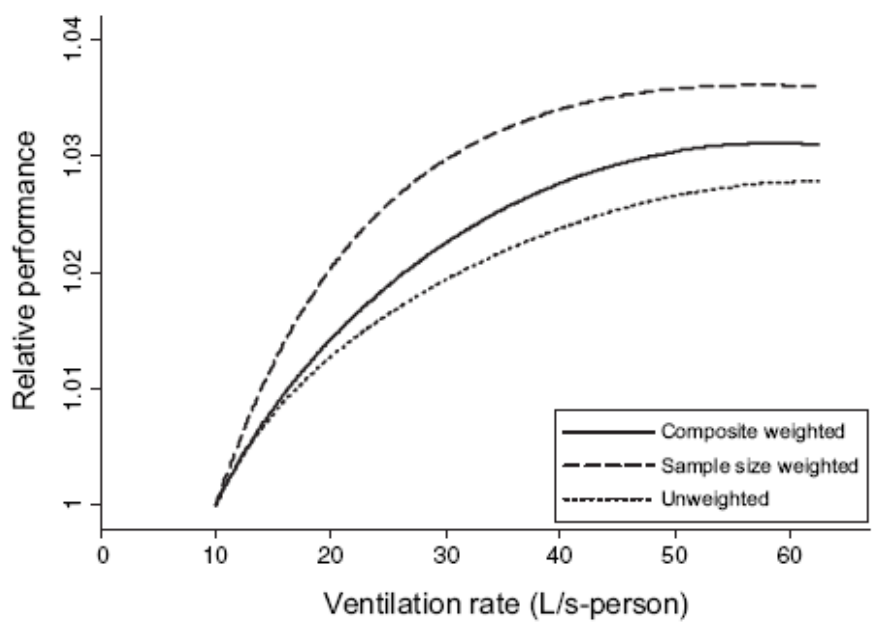
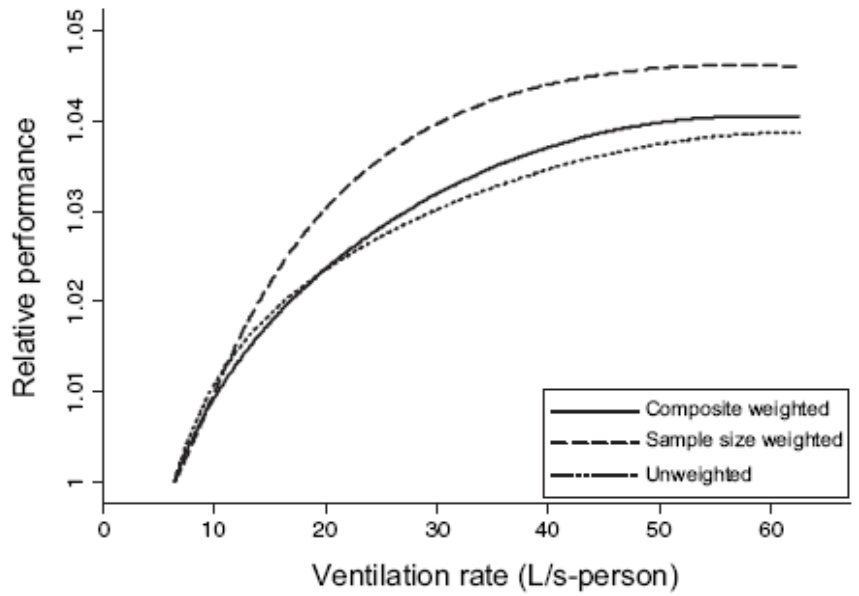

Figure 2. Relative performance in relation to the reference values 6.5 l/s-person (upper) and 10 l/s-person (lower) vs. ventilation rate according to Rehva Guide No 6. The outlier data point is not included. Source: Seppänen et al. (2006b).

Table 1. Prevalence (%) of adverse environmental perceptions and symptoms in various office types.
Adapted from Pejtersen et al. (2006).

<i>Perception or symptom</i>	<i>Office size (number of occupants per room)</i>				
	<i>1</i>	<i>2</i>	<i>3-6</i>	<i>7-28</i>	<i>>28</i>
Too high temperature	11	10	21	23	34
Varying temperature	8	14	17	28	25
Too low temperature	6	10	14	17	17
Stuffy air	21	29	36	42	54
Dry air	19	25	31	39	50
Noise in the room	6	15	28	42	60
Inadequate lighting	9	13	15	20	23
Reflections (glare)	11	13	15	21	26
Fatigue	8	12	12	17	21
Headache	10	14	13	19	25
Difficulties concentrating	2	6	6	8	16

Table 1 shows the most important of the statistically significant results of Pejtersen et al. (2006). Occupant dissatisfaction with, among others, thermal comfort, indoor air quality, noise in the room, lighting and reflections (glare) and BRS, among them fatigue, headache and difficulties in concentrating, all rise with increasing number of occupants per workroom. Similar results were found by Wilson and Hedge (1987), Zweers et al. (1992), Fisk et al. (1993) and Brasche et al. (2001). Therefore it is expected that performance will increase by housing workers in cellular offices instead of in open plan offices.

The effect of thermal discomfort is difficult to quantify as there is no direct relation between the several aspects of discomfort in table 1 and the relations found in the previous paragraph.

The effect of dissatisfaction with indoor air quality can be quantified if we assume that the percentage of workers reporting dry air¹ is a good proxy for the percentage dissatisfied with indoor air quality. If we take two occupants per workroom as reference level, the effect of indoor air quality varies from 0.6% performance loss for 3 to 6 occupants per workroom to 2.5% for more than 28 occupants per room.

The effect of dissatisfaction with noise in the room cannot be deduced from table 1 directly, but Hongisto (2005) gives a relation of performance with STI (Speech Transmission Index) based on a large number of studies from which it can be deduced that performance loss caused by noise in the room will vary from 3% in a acoustically well designed open plan office to 7% in a acoustically poorly designed open plan office (figure 3).

¹ Perception of dry air is caused by indoor air pollutants rather than by low air humidity

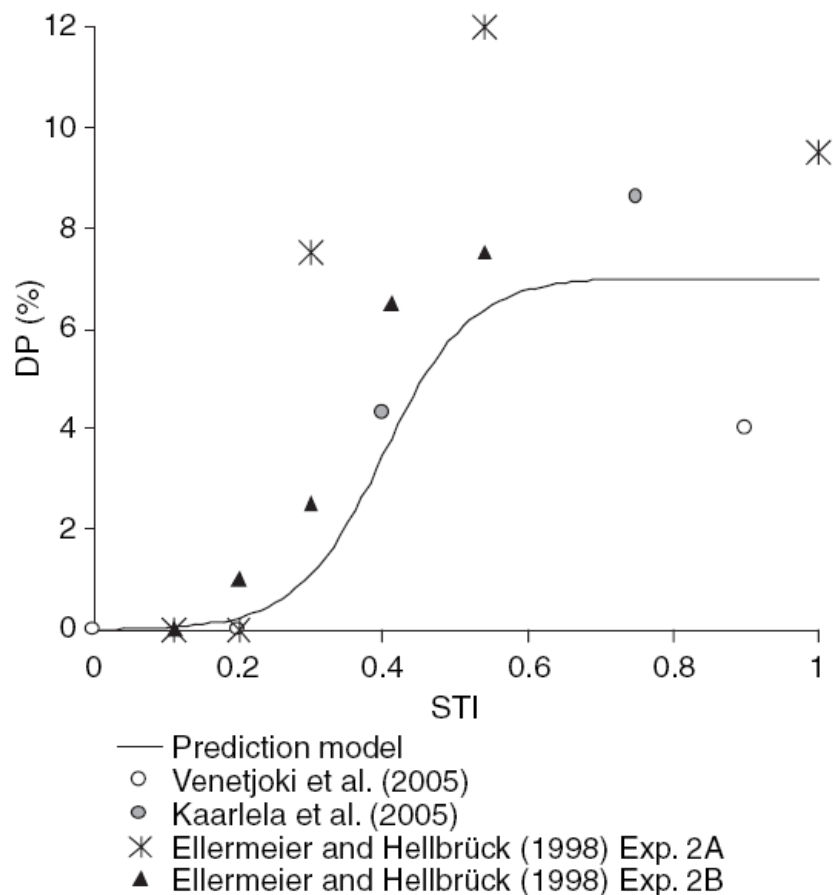

Figure 3: The schematic prediction model, which gives the decrease in performance, DP, as a function of the STI. The highest performance is obtained when no speech is heard (STI $\frac{1}{4}$ 0.00, conventional office) and the highest performance decrease is reached when speech is highly intelligible (STI > 0.70, poor open-plan office), irrespective of sound level of speech. The normalization constant of Equation 1 was $A_2 \frac{1}{4}$ 7%. Source: Hongisto (2005).

The effects of inadequate lighting and glare cannot be quantified with present knowledge, but some effects are expected. Heschong Mahone Group (2003) found that a higher risk of glare decreased mental test performance by 15% to 21%. They also found that workers in a call-centre were found to process calls 7% to 12% faster when they had the best possible outside view versus those with no view. These figures are possibly an overestimation because of lack of control for confounders: glare and the quality of the view may be proxies for other relevant workplace characteristics. Frontczak et al. (2012) confirm the importance of the view from the workplace: people sitting close to a window expressed significantly higher workplace satisfaction than those further from a window.

The effect of BRS (including fatigue, headache, difficulties concentrating) cannot be quantified with present knowledge. The Rehva Guide lists a number of studies but concludes that a meta-analysis is problematic because of large differences in design and definitions. Two studies measured call-centre performance and simultaneously registered BRS. Both studies show that a reduction of central nervous symptoms (e.g. headaches, difficulty to think clearly) corresponds to improved performance. So the increase of BRS with larger room size is expected to lower performance.

Cellular offices allow for occupant control of temperature in a way that open plan offices do not. Based on a theoretical model, Wyon (2000) predicts a performance gain of 2.7 to 8.6% with an average of 5.4% for various different tasks when occupants can control their thermal environment. To be on the safe side it is assumed that the effect in offices will be 2.7 to 5.4%, which is supported by a 4% gain found in a field study (Kroner & Stark-Martin, 1994).

The Rehva Guide proposes the following rule to add several different performance effects: The magnitude of the combined effects is at least the effect of the greater of the single parameters, and not more than the sum of the independent parameters. When we apply this carefully with some creativity to the effect of housing in open plan offices instead of in cellular, two person offices with occupant control of temperature, the effect is 3 to 14.9% performance loss, possibly plus the unknown effects of dissatisfaction about lighting, glare and view and of BRS and an unknown residual effect of thermal discomfort (it is assumed that the unknown effect of thermal discomfort is already for the most part incorporated in the effect of occupant control of temperature). Actually a minimum effect somewhat higher than 3% is to be expected because Raw et al. (1990) shows that, albeit for self estimated performance, the effects of open plan offices and of lack of occupant control are independent, so some additivity of the two is expected.

The above shows that avoidance of indoor air pollution sources and housing in cellular offices are more effective in increasing performance than increasing ventilation. There is yet another problem with increasing ventilation instead of avoiding indoor air pollution sources. In some situations increased ventilation leads to increased emission of pollutants. Wargocki et al. (2004), a field study, shows that when the ventilation rate is increased in the case of used, polluted filters increased ventilation leads to a decrease of the perceived indoor air quality and of performance. The conclusion is that the increased ventilation leads to higher emission of pollutants from the polluted filters. A similar effect on perceived indoor air quality is found by Alm, Clausen and Fanger (2000) and by Strøm-Tejsen, Clausen and Toftum (2003), both studies showing that the pollution load from a used filter increases proportionally with the air velocity across the filter. It cannot be excluded that this also applies to other pollution sources within the HVAC system. Another example of increased pollutant emission as a result of increased ventilation is given by Bakó-Biró (2004) The results show that if the indoor air contains pollutants that are sensitive to oxidation, like terpenes, emission of pollutants increases with increased ventilation if the ventilation air contains ozone. These examples show that in various situations, increasing ventilation may lead to higher emission of pollutants. This problem can of course be eliminated by strict avoidance of pollution sources. When this strategy is followed, it is sufficient to apply a low but adequate ventilation level, which can be delivered by simple mechanical ventilation or even by natural ventilation.

5 Ventilation rate, workroom layout and sickness absenteeism

The Rehva Guide presents a quantitative relationship between ventilation rate and short-term sickness absenteeism by combining published data from four field studies and making use of the Wells-Riley equation, plus a theoretical model of airborne transmission of respiratory infections (Fisk et al., 2003). These relations are shown in figure 4. The particle concentration model curve uses a simple model in which the disease prevalence is proportional to the reciprocal of the total infectious particle removal rate. A rough estimate using the presented relationship suggests a 10%

reduction in illness for doubling of outdoor air supply rate. The Rehva Guide states that this relationship is only valid in open plan offices or when the air is recirculated within the office building. This suggests the possibility to reduce absenteeism caused by infectious diseases by avoiding both open plan offices and recirculation.

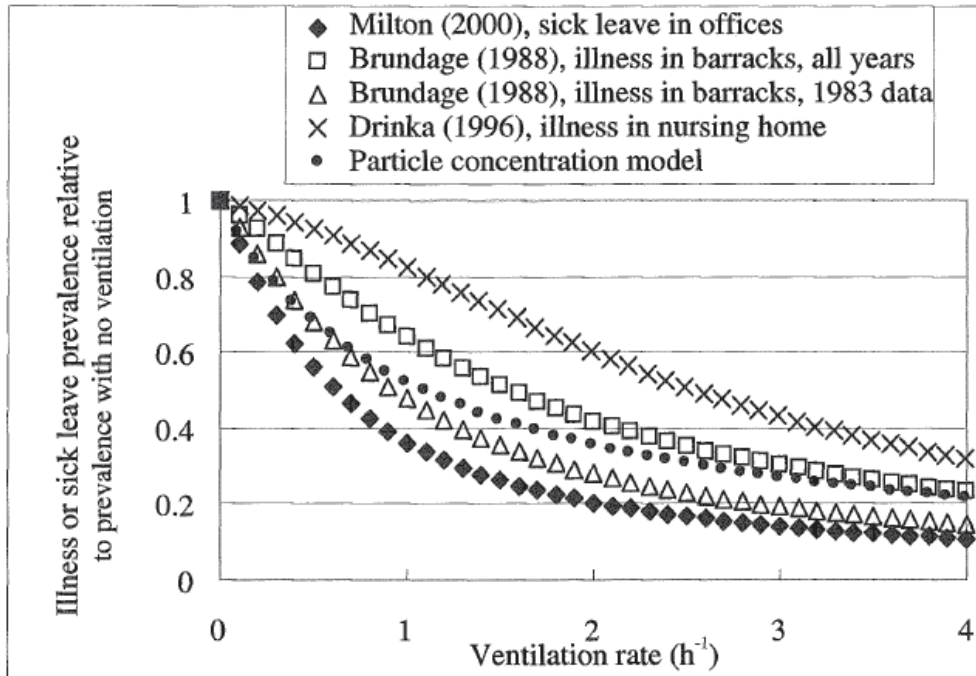

Figure 4: Predicted trends in illness of sick leave versus ventilation rate. Source: Fisk et al. (2003).

At least one study (Jaakkola and Heinonen, 1995) shows that workers working in single rooms have less objectively registered episodes of the common cold than workers who share their work space with others. It is however more interesting to know what the effect would be of housing in two or three person rooms, because that is the most frequent layout in the case of cellular offices, at least in The Netherlands. Furthermore the contacts that workers have visiting other rooms should be accounted for. Thus either we need more empirical data about the relation between office layout and registered absenteeism, or at least a theoretical model to predict the effect of office layout. For the latter we need at least empirical data about the frequency and length of visits to other rooms. All this is beyond the scope of this paper. For the time being the conclusion is that avoiding open plan offices and recirculation is at least an effective alternative to increasing ventilation rate when it come to reducing absenteeism.

6 Indoor air pollution sources and sickness absenteeism

Milton et al. (2000) is one of the few well executed studies based on objectively registered absenteeism. It shows that the effect of the use of a humidifier in the HVAC system on total absenteeism is of approximately the same size as the effect of reducing ventilation rates from 24 to 12 l/s*person. The humidifiers in this study included steam, spray and finfill devices. Milton et al. (2000) gives as a possible explanation of the association of humidification with increased absenteeism that humidification may have promoted increased bioaerosol exposure. More generally it can be stated that using a humidifier increases absenteeism because it can be an

indoor air pollution source. Eliminating several or all indoor air pollution sources may be more effective in reducing absenteeism than doubling the ventilation rate.

7 Workers' satisfaction with the indoor environment and sickness absenteeism

Table 3: Annual absenteeism for office workers only. Adapted from Milton et al. (2000).

Area with formally registered Indoor air complaints	Long-term absenteeism (> 10 days)	Short-term absenteeism (≤ 10 days)
No	2.17%	1.60%
Yes	1.30%	1.91%

The results of Milton et al. (2000) also show that the effect of working in an area *with formally registered indoor air complaints* on short-term absenteeism is of approximately the same size as the effect of higher ventilation compared to lower ventilation. Table 3 shows long-term and short-term absenteeism for areas with or without indoor air complaints for office workers only, as found in Milton et al. (2000). Presence of complaints was defined as whether a formal complaint had been made to the corporate environmental health and safety office within the last three years. It was found that working in a complaint area increases only short-term absenteeism. A plausible explanation for this is as follows: Generally there are two paths along which work related burdens can increase absenteeism (Oversloot, 1995):

- The burdens directly cause the illness or the medical complaints, e.g. lifting too heavy loads causes back pain or contact with contaminated blood causes infectious disease.
- The burden does not in itself cause illness but it does cause dissatisfaction with the work environment and diminished loyalty to the organisation. When an employee suffers from a non serious illness (e.g. common cold or headache) he or she is not necessarily incapable of working, but the diminished loyalty will increase the probability that he or she reports ill. Moreover, when the symptoms decrease at the end of the sickness period, the employee has a certain latitude of choice to report well earlier or later, and if possible he or she will postpone reporting well (e.g. from Friday till Monday) if loyalty to the organisation is low. This of course also depends on the legal and cultural tolerance towards reporting ill, which can vary considerably among organisations and countries. Because this mechanism normally only works in the case of non serious illness and its relative effects are greater in the case of short sick leave it leads to an increase of short-term absenteeism rather than of long-term absenteeism.

Published data indicate that indoor air problems increase absenteeism along the two paths described above: On the one hand inadequate ventilation and indoor air pollution increase the probability of infectious illnesses like influenza and the common cold (see the literature reviewed in Milton et al., 2000). On the other hand Robertson et al. (1990) reports that when workers from the same organisation move from a building part with good indoor air quality to a part with poor indoor air quality, the registered absenteeism increases in *all* diagnose categories, and not only in those that are indoor air quality related. Workers who move in the opposite direction show a decrease of absenteeism in *all* diagnose categories. This indicates that poor air quality increases the probability of reporting ill and of postponing reporting well even if the illness itself is not related to indoor air quality. The results from Milton et al. (2000) in table 3 support this view. It turns out that in building parts with a high level of indoor air complaints there is more short-term absenteeism compared to building parts

with a low level of complaints which is what would be expected if indoor air complaints would at least partly increase absenteeism *via* decreasing loyalty². A typical situation that decreases loyalty is working in an open plan office. This causes dissatisfaction about many aspects of the indoor environment and BRS (Pejtersen et al. 2006) and lowers both self-estimated (Raw et al., 1990) and objectively measured performance (this paper). Loyalty will be especially reduced when it is a management decision to work in an open plan layout and workers would prefer cellular offices.

8 Self reported absenteeism

The results above are based on objectively registered absenteeism. This allows for stronger conclusions than self reported absenteeism, but there are few studies based on objectively reported absenteeism. It is therefore interesting to see if the above results are supported by data concerning self reported absenteeism. We have decided to include three well executed studies. The first study (Preller et al. 1990a) concerns a large number of workers (7043) and buildings (61), which, apart from self reported absenteeism, includes data about workers' satisfaction with the indoor environment and BRS. Furthermore, a large number of worker, building and workplace characteristics were registered and multivariate analysis was applied. Table 4 shows the relevant results. In this publication both types of humidifiers are associated with an increase of all measures of self reported absenteeism. From Preller et al. (1990a) it is known that the characteristic *mechanical cooling*, which in this study correlates highly with the presence of humidifiers and in the univariate analysis correlates significantly with BRS and dissatisfaction, was not included in the multivariate analysis to avoid collinearity problems. This implies that in this publication the characteristics *spray or steam humidifier* actually stand for the characteristic *humidifier and/or mechanical cooling*, which supports the earlier conclusion that indoor air pollution sources in general increase absenteeism. The characteristic *satisfied with IEQ complaint handling* is a good proxy for the absence of complaints about the indoor environment, since dissatisfaction with complaint handling is only to be expected when there are IEQ problems to complain about. So the relation of this characteristic with a decrease of all self reported absenteeism measures supports the earlier conclusion that general workers' satisfaction with the indoor environment decreases absenteeism. (The presentation of the data does not allow for a conclusion specific to short-term absenteeism). Preller et al. (1990a) find no relation of any of the absenteeism measures with the number of workers per room, in this publication defined as ≥ 10 versus < 10 .

The second study (Pejtersen et al., 2011) and the third study (Bodin Danielsson et al, 2014) concern the relation of self reported absenteeism with the number of workers per office room. In both articles the analysis was adjusted for relevant confounders. Tables 5 and 6 give the results. In the second study the two-person room does not show lower absenteeism than larger rooms. The one-person room does show some 30% lower absenteeism. In the third study single person rooms and two to three person rooms show some 40% resp. 30% lower short term absenteeism than open plan offices. Although these results are not entirely consistent, they indicate that housing in one to three person offices is about a factor 3 more effective than doubling the ventilation rate in an open plan office.

² The lower long-term absenteeism in the case of an area with registered complaints cannot be accounted for with the given data, but in any case it does not refute the assumption that workers' dissatisfaction increases short-term rather than long-term absenteeism.

Table 4. Multivariate analysis of characteristics associated with self reported absenteeism. Adapted from Preller et al. (1990a).

Odds ratios, 95% CI	General absenteeism		Absenteeism assigned by the worker to work related complaints	
	Number of sick leaves, >1 vs. ≤	Number of days, >1 vs. ≤	Number of sick leaves, >1 vs. ≤	Number of days, >1 vs. ≤
Spray humidifier	0.77 0.62 – 0.95	0.75 0.61 – 0.93	0.64 0.46 – 0.88	0.77 0.60 – 1.00
Steam humidifier	0.78 0.64 – 0.96	0.80 0.65 – 0.98	0.51 0.37 – 0.69	0.70 0.55 – 0.89
Satisfied with IEQ complaint handling	1.56 1.36 – 1.78	1.48 1.30 – 1.70	2.16 1.79 – 2.60	1.86 1.60 – 2.16

Table 5. Multivariate analysis of association of self reported absenteeism with the number of workers per office room. Adapted from Pejtersen et al. (2011).

Number of workers	1	2	3-6	>6
Odds ratios, 95% CI	1	1.50 1.13-1.98	1.36 1.08-1.73	1.62 1.30-2.02

Table 6. Multivariate analysis of association of self reported short term absenteeism with the number of workers per office room. Adapted from Bodin Danielsson et al. (2014).

Number of workers	1	2-3	4-9	10-24	>24
Odds ratios, 95% CI	1	1.23 0.81-1.86	1.90 1.16-3.10	1.92 1.08-3.40	1.82 1.14-2.88

9 Discussion and conclusions

The Rehva Guide states that its main purpose is to establish quantitative relationships of indoor environmental aspects with performance and absenteeism³. The purpose of this paper is to establish what in practice are, or probably are, the most effective measures to increase performance and reduce absenteeism, given the total of the presently available evidence. Pursuing this purpose we come to the following conclusions:

³ The authors of the Rehva Guide have decided not to establish qualitative relationships due to a “*very high level of uncertainty*” (italics added) they suppose them to have. At the same time, concerning the main quantitative relationships established in the Rehva Guide (temperature with performance, ventilation with performance and ventilation with absenteeism) the publications on which these relationships are based (Seppänen et al., 2006a, Seppänen et al., 2006b, Fisk et al., 2003) state that these relationships have a high level of uncertainty, that, however, use of these relationships may be preferable to current practice, which ignores productivity. We feel that qualitative relationships or relationships based on dichotomous variables can be just as relevant for design decisions as quantitative relationships and do not necessarily have a high level of uncertainty. When one considers the total of presently available evidence measures like cellular workroom layout combined with shallow plan depth or avoidance of indoor air pollution sources, including HVAC components, building materials and office equipment, have a relatively good chance of substantially improving workers’ performance and reducing absenteeism. Given the present state of knowledge the decision not to establish qualitative relationships causes the Rehva Guide to be biased in favour of measures that often have a relatively low effect, have a high level of uncertainty and will in most cases increase energy consumption, and to be biased against measures that can have a relatively high effect, have a relatively low level of uncertainty and will in many cases reduce energy consumption (see the end of section 9).

Concerning the impact of temperature on performance:

- The relationship presented in the Rehva Guide, where performance is maximal at 21.75°C, cannot be extrapolated to free running environments.
- In free running environments we expect performance to be maximal at the matching comfort temperature, which can be considerably higher than 21.75°C.
- When it comes to comparing air conditioned environments at the matching comfort temperature and free running environments at the matching comfort temperature, we expect performance to be higher in free running environments because therein occupant satisfaction with the indoor environment will be higher and BRS, including fatigue, headache and problems concentrating, will be less.

Concerning the impact of ventilation on performance:

- Strict avoidance of indoor air pollution sources is more effective (a factor 10 or more) in raising performance than increasing the ventilation rate above 10 l/s*person.
- Housing in small (two-person) cellular offices with occupant control of temperature is more effective (a factor 3 to 15 or more) in raising performance than increasing the ventilation rate above 10 l/s*person.
- Avoidance of pollution sources and housing in cellular offices have a high probability of increasing performance and will have no negative side effects. Increasing the ventilation rate may result in lower performance when there are pollution sources in the HVAC system or when there are pollutants in the indoor air that are sensitive to oxidation and increased ventilation rate increases the indoor concentration of ozone.

Concerning the impact of ventilation on absenteeism:

- The relation of absenteeism with ventilation rate in the Rehva Guide and the results of Jaakkola and Heinonen (1995) imply that avoiding open plan offices and recirculation is at least an effective alternative to increasing ventilation rate when it comes to reducing absenteeism. The studies concerning the relation of self reported absenteeism with the number of workers per office room indicate that housing in one to three person offices is more effective (about a factor 3) than doubling the ventilation rate in an open plan office.
- Avoiding a typical indoor air pollution source like a humidifier is about as effective as doubling the ventilation rate from approximately 12 to approximately 24 l/s*person. Avoidance of several or all pollution sources may be more effective than that.
- All measures which improve workers' satisfaction with the indoor environment, including those which are unrelated to infection risk or indoor air quality, will lower absenteeism because the improved satisfaction will increase workers' loyalty to the organisation and thereby decrease both the probability of reporting ill and the probability of postponing reporting well in case of non serious illness.

In Leyten and Kurvers (2006) Leyten, Kurvers and Van den Eijnde (2009) and Leyten and Kurvers (2011) the authors of this paper have argued that workers' satisfaction with the indoor environment is for an important part determined by the *robustness* of the building. Robustness is defined as the measure by which the IEQ delivered by the building lives up to its design purpose when it is used by occupants in a real life situation. According to these publications examples of robust measures are:

- Avoidance of indoor air pollution sources in the workrooms and in the HVAC system.
- Minimizing external and internal heat load.
- Using thermal effective building mass.
- Housing in cellular offices combined with shallow plan depth.
- Occupant control of temperature.
- Operable windows which the workers can open and adjust at will.
- Offering a comfortable thermal environment without mechanical cooling, using adaptive thermal comfort

Examples of less robust measures are:

- Diluting indoor air pollution through increased ventilation instead of avoiding pollution sources.
- Controlling temperature through mechanical cooling instead of reducing external and internal heat load, using thermal effective building mass and offering the occupants adaptive opportunities.
- Open plan workroom layout combined with deep plan depth.

Leyten and Kurvers (2006), Leyten, Kurvers and van den Eijnde (2009) and Leyten and Kurvers (2011) intended to show that robust measures, especially when combined, are likely to result in much more occupant health and satisfaction than less robust measures. This paper intends to show that robust measures are more effective in increasing objectively measured workers' performance and in reducing sickness absenteeism than less robust measures.

If one is prepared to accept large effects concerning self reported performance as indicators of objective performance, this argument can be pressed one step further. One important robust measure that we discussed in Leyten, Kurvers and van den Eijnde (2009) is offering the occupants an environmental *Gestalt* that promotes acceptance. This is the case if the following conditions apply simultaneously:

- Aberrations from “comfortable”, “preferred” or “neutral” can be reduced or compensated for by the occupants in a feasible way and without negative side effects for themselves or others. This includes control of the environment and control of personal factors like activity and clothing. If there are negative side effects the control opportunities should allow for trading off positive and negative results of choices against one another.
- Remaining aberrations from “comfortable”, “preferred” or “neutral” are understandable on the basis of transparency of the functioning of the building and its systems to the occupants.
- Remaining aberrations from “comfortable”, “preferred” or “neutral” are judged equitable by the occupants on the basis of understanding the aberrations and on the basis of perceived co-responsibility for the environment through occupant control. (Transparency concerns the working of the building system; understanding concerns the aberrations).

This may seem a rather abstract concept, but there exists a very good proxy measure for it. In their presentation “Are building users more tolerant of ‘green’ buildings” Adrian Leaman and Bill Bordass introduce the concept of “forgiveness” which is the measure by which occupants positively value the indoor environment as a whole despite individual shortcomings because the indoor environment as a whole promotes satisfaction. They derive a forgiveness score for a given building by dividing the

average score given by the occupants for “comfort overall” by the average of the scores given for temperature in summer and winter, ventilation/air in summer and winter, noise and lightning. Scores above 1.0 indicate a higher level of forgiveness. In our view forgiveness defined in this way is an excellent empirical measure of what we have called the acceptance promoting environmental *Gestalt*. Figure 5 shows the results of a set of “green” and conventional buildings from the UK. (A set of Australian buildings shows very similar results). The correlation of self reported performance with forgiveness is strong: 0.75. The performance score of the buildings with the highest forgiveness score is some 20% higher than of the buildings with the lowest forgiveness score. So even an abstract robust measure like the acceptance promoting *Gestalt* can be shown to raise performance. Furthermore the acceptance promoting *Gestalt*, or in other words forgiveness, is also expected to improve workers’ loyalty and thus to decrease both the probability of reporting ill and the probability of postponing reporting well in case of non serious illness.

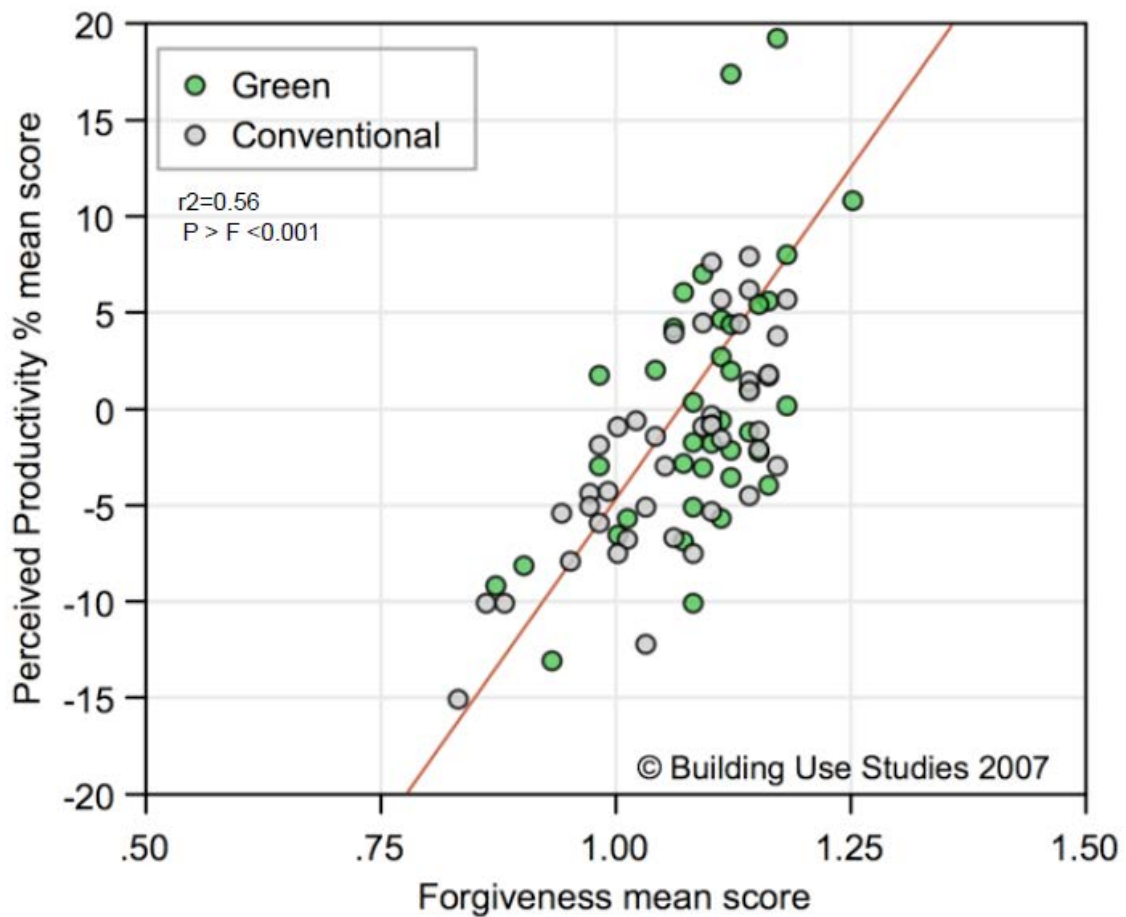

Figure 5: Forgiveness and perceived productivity. Source: presentation “Are building users more tolerant of ‘green’ buildings” by Adrian Leaman and Bill Bordass.

Since data concerning performance and absenteeism are important objectively measurable indicators of IEQ and these data were not used in forming the building robustness hypothesis in our earlier publications, we consider these results an important independent corroboration of the building robustness hypothesis.

Although we have not yet developed this in detail, an extension of the building robustness hypothesis is that robust measures as we define them not only promote health, comfort and productivity, but also lead to lower energy consumption. A few points to make this plausible:

- Roulet (2006) argues that to achieve both good IEQ and low energy consumption one should control the indoor environment as much as possible through passive measures and apply active measures only to fine-tune the indoor environment where necessary. Important instances of this strategy are control of indoor air pollution sources instead of relying on increased ventilation and temperature control through control of heat sources and building physics instead of relying on mechanical cooling.
- Knudsen and Wargocki (2010) confirm that control of indoor air pollution sources instead of relying on increased ventilation lowers energy consumption.
- Offering a comfortable thermal environment without mechanical cooling using adaptive thermal comfort will, when well applied, lower energy consumption.
- The combination of cellular workroom layout and shallow plan depth allows for natural ventilation or else simple mechanical ventilation instead of more energy consuming elaborate HVAC systems.
- Kurvers et al. (2013) is a preliminary study using two databases: one Dutch database that includes predicted and actual energy use of a set of buildings, and the European Hope database that includes health and comfort scores. Next to that both databases include building characteristics. In this study, the buildings were divided into nine typologies. The results show that the buildings with a combination of characteristics denoted as “climate oriented” had the lowest energy consumption as well as the lowest Building Symptoms Index, whereas the building type “climate ignoring” showed higher energy consumption as well as a higher Building Symptom Index.

References

- Alm, O., Clausen, G., Fanger, P.O., 2000. Exposure-response relationships for emissions from used ventilation filters. In: *ISIAQ Proceedings Healthy Buildings 2000*. Espoo, Finland, 6 – 10 August, 2000.
- Bakó-Biro, Z., 2004. *Human perception, SBS symptoms and performance of office work during exposure to air polluted by building materials and personal computers*. Ph.D. Technical University Denmark.
- Bluyssen, P.M., Cox, C., Seppänen, O., Oliveira Fernandes, E. de, Clausen, G., Müller, B., Roulet, C.A., 2003. Why, when and how do HVAC-systems pollute the indoor environment and what to do about it? The European AIRLESS project. *Building and Environment*, 38, pp 209-225.
- Bodin Danielsson, C., Singh Chungkham, S., Wulff, C., Westerlund, H., 2014. Office design's impact on sick leave rates. *Ergonomics*, DOI: 10.1080/00140139.2013.871064.
- Brashe, S., Bullinger, M., Morfeld, M., Gebhart, H.J., Bischof, W., 2001. Why do women suffer more from sick building syndrome than men? - Subjective higher sensitivity versus objective causes. *Indoor Air*, 11(4), pp 217-222.
- de Dear, R., Brager, G., Cooper, D., 1997. *Developing an adaptive model of thermal comfort and preference*. ASHRAE RP-884.
- Fitzner, K., 2000. Control of pollutants in air handling systems. In: *ISIAQ Proceedings of Healthy Buildings 2000*. Espoo, Finland, 6 – 10 August, 2000.

Fisk, W.J., Mendell, M.J., Daisey, J.M., Faulkner, D., Hodgson, A.T., Nematollahi, M., Macher, J.M., 1993. Phase 1 of the California Healthy Buildings Study: a Summary. *Indoor Air*, 3, pp 246 - 254.

Fisk, W., Seppänen, O., Faulkner, D., Huang, J., 2003. Economizer system cost effectiveness: accounting for the influence of ventilation rate on sick leave. In: *ISIAQ Proceedings Healthy Buildings 2003 – Energy Efficient Healthy Buildings*. Singapore, 7 – 11 December 2003.

Frontczak, M., Schiavon, S., Goins, J., Arens, E., Zhang, H., Wargocki, P., 2012. Quantitative relationships between occupant satisfaction and satisfaction aspects of indoor environmental quality and building design. *Indoor Air*, 22(2), pp 119-131.

Heschong Mahony Group, 2003. *Windows and offices: A study of office worker performance and the indoor environment – Technical Report*. California Energy Commission.

Hongisto, V., 2005. A model predicting the effect of speech of varying intelligibility on work performance. *Indoor Air*, 15(6), pp 458-468.

Jaakkola, J.J.K., Heinonen, O.P., 1995. Shared office space and the risk of the common cold. *European Journal of Epidemiology*, 11, pp 213-216.

Kroner, W.M., Stark-Martin, J.A., 1994. Environmentally responsive workstations and office-worker productivity. *ASHRAE Transactions*, 100(2), pp 750-755.

Knudsen, H.N., Wargocki, P., 2010. Strategy for good perceived air quality in sustainable buildings. In: *REHVA Proceedings Clima 2010, 10th REVHA World Congress 'Sustainable Energy Use in Buildings'*, Antalya, Turkey, 9 – 12 May, 2010: Turkish Society of HVAC & Sanitary Engineers.

Kurvers, S.R., Raue, A.K., Ham, E.R. van den, Leyten, J.L., Juricic, S.M.M., 2013. Robust climate design combines energy efficiency with occupant health and comfort. *ASHRAE IAQ 2013 Proceedings: Environmental Health in Low-Energy Buildings*. Vancouver, Canada, 15 – 18 October, 2013, Atlanta GA: ASHRAE.

Leyten, J.L., Kurvers, S.R., 2006. Robustness of buildings and HVAC systems as a hypothetical construct explaining differences in building related health and comfort symptoms and complaint rates. *Energy and Buildings*, 38, pp 701-707.

Leyten, J.L., Kurvers, S.R., van de Eijnde, J., 2009. Robustness of office buildings and the environmental Gestalt. In: *Santanam, S., Bogucz, E.A., Peters, C., and Benson, T., Healthy Buildings 2009 Proceedings of the 9th International Healthy Buildings Conference and Exhibition*. Syracuse, NY, USA, 13 – 17 September 2009, ISIAQ.

Leyten, J.L., Kurvers, S.R., 2011. Robust indoor climate design. In: *ISIAQ Proceedings Indoor Air 2011*. Austin, USA, 5 – 10 June, 2011, ISIAQ.

Milton D.K., Glencross P.M., Waters M.D., 2000. Risk of sick leave associated with outdoor air supply rate, humidification and occupant complaints. *Indoor Air*, 10, pp 212-221.

Nicol, F., Humphreys, M., 2005. Adaptive comfort in Europe: results from the SCATs survey with special reference to free running buildings. In: *Proceedings of the international conference on EPDB Energy Performance of Buildings Directive: implementation in practice*, Brussels, 21 – 23 September 2005.

Oversloot J., 1995. *Verzuimbeheersing (Absenteeism Control)*. The Netherlands: Delwel.

Pejtersen, J., Allerman, L., Kristensen, T.S., Sjøström, M., 2006. Indoor climate, psychosocial work environment and symptoms in open-plan offices. *Indoor Air*, 16(5), pp 392-401.

- Pejtersen, J., Feivelle, H., Christensen, K.B., Burr, H., 2011. Sickness absence associated with shared and open plan offices – a national cross sectional questionnaire survey. *Scand J Work Environ Health*, 37(5), pp 376-382.
- Preller, L., Zweers, T., Boleij, J., Brunekreef, B., 1990a. *Gezondheidsklachten en klachten over het binnenklimaat in kantoorgebouwen*. The Netherlands: Directoraat-Generaal van de Arbeid. (The original Dutch publication of the study reported in Preller et al., 1990b)
- Preller, L., Zweers, T., Brunekreef, B., Boleij, J., 1990b. Sick leave due to work-related health complaints among office workers in the Netherlands. In: ISIAQ Indoor Air '90, *Proceedings of the 5th International Conference on Indoor Air Quality and Climate*. Toronto, Canada, July 29 – August 3 1990.
- Raw, G.J., Roys, M.S., Leaman, A., 1990. Further findings from the office environment survey: productivity. In: ISIAQ Indoor Air '90, *Proceedings of the 5th International Conference on Indoor Air Quality and Climate*. Toronto, Canada, July 29 – August 3 1990.
- Robertson A.S., Roberts K.T., Burge P.S., Raw G., 1990. Effect of change in building ventilation category on sickness absence rates and the prevalence of sick building syndrome. In: ISIAQ Indoor Air '90, *Proceedings of the 5th International Conference on Indoor Air Quality and Climate*. Toronto, Canada, July 29 – August 3 1990.
- Roulet, C.A., 2006. Indoor air quality and energy performance of buildings. In: E. de Oliveira Fernandes, M. Gameiro da Silva, J. Rosado Pinto, *HB 2006 healthy buildings - Creating a healthy indoor environment for people - Proceedings*. Lisboa, Portugal, 4 – 8 June 2006, ISIAQ.
- Seppänen, O., Fisk, W.J., Lei, Q.H., 2006a. Effect of temperature on task performance in office environment. In: *Cold Climate HVAC 2006, Proceedings of The 5th International Conference on Cold Climate - Heating, Ventilating and Air-Conditioning*. Moscow, Russia, 21 – 24 May 2006, Moscow, Russia: Russian Association of Engineers for Heating, Ventilation, Air-Conditioning, Heat Supply & Building Thermal Physics (ABOK).
- Seppänen, O., Fisk, W.J., Lei, Q.H., 2006b. Ventilation and performance in office work. *Indoor Air*, 16(1), pp 28-35.
- Strøm-Tejsten, P., Clausen, G., Toftum, J., 2003. Sensory pollution load from a used ventilation filter at different air flow rates. In: *ISIAQ Proceedings Healthy Buildings 2003 – Energy Efficient Healthy Buildings*. Singapore, 7 – 11 December 2003.
- Wargocki, P., Wyon, D.P., Fanger, P.O., 2004. The performance and subjective responses of call-centre operators with new and used supply air filters at two outdoor air supply rates. *Indoor Air*, 14(Suppl 8), pp 7-16.
- Wilson, S., Hedge, A., 1987. *The Office Environment Study - A Study of Building Sickness*. Building Use Studies Ltd, London.
- Wyon, D.P., 2000. Individual control at each workplace: the means and the potential benefits. In: Clements-Croome, D (ed.), *Creating the productive workplace*. London: E & FN SPON, pp 192-206.
- Zweers, T., Preller, L., Brunekreef, B., Boleij, J.S.M., 1992. Health and Indoor Climate Complaints of 7043 Office Workers in 61 Buildings in the Netherlands. *Indoor Air*, 2(1), pp 127-136.

A field-comparison of thermal comfort with floor heating systems and air conditioning systems in Japanese homes

Hom B. Rijal¹, Toshiaki Omori², Michael A. Humphreys³, J. Fergus Nicol³

¹ *Faculty of Environmental Studies, Tokyo City University, Yokohama, Japan*

² *Tokyo Gas Co., Ltd., Yokohama, Japan*

³ *School of Architecture, Oxford Brookes University, Oxford, UK*

¹ rijal@tcu.ac.jp, ² omoritoshi@yahoo.co.jp, ³ mahumphreys@brookes.ac.uk, ³ jfnicol@brookes.ac.uk

Abstract

Floor heating is characterized by small horizontal and vertical temperature differences, and might be especially suitable for Japanese homes where it is customary to sit on the floor. This paper compares thermal comfort in homes while floor heating systems and air conditioning systems were in use during winter. Each dwelling had both a floor heating system and an air conditioning system, each used on alternate weeks during the survey period. Throughout the survey periods residents were asked about their current thermal sensation, thermal preference, overall comfort and foot-comfort. Air temperature, globe temperature, humidity and floor surface temperature were recorded. More than 6,000 were collected from 50 dwellings. The results showed that a floor heating system was preferred, and that it was more effective in providing a comfortable environment.

Keywords: Thermal comfort; comfort temperature; floor heating; air conditioning

1 Introduction

Floor heating is characterized by small horizontal and vertical temperature differences, and might therefore be especially suitable for Japanese homes where it is customary to sit on the floor.

Earlier research has included questionnaire surveys and climate chamber studies (Kagiya et al. 2007, Matsumae et al. 2007, Emoto et al. 2009). They found that floor heating was considered comfortable. They also found that an air conditioning heating system was found to be comfortable, and that their respondents thought the comfort level of the two systems not very different. Only university age students were used in the climate chamber study, while the questionnaire used in the survey work did not focus on the ways in which comfort might have differed between the two systems. There is in Japan a general opinion, held by residents who use floor heating systems, that they have advantages over air conditioning systems. Further exploration of the question therefore seemed to be desirable.

We first conducted a web-survey on 7th and 8th of February 2011. It has been reported elsewhere (Rijal & Omori 2011, Rijal et al. 2012), so only a brief account is given here. Respondents were asked to stay in the heated living room for an hour or more before they filled in an on-line questionnaire. The questions asked about, among other matters, whole-body thermal sensation and thermal preference, and also asked about the warmth and comfort of the feet. All respondents were over 20 years old. Residents measured the room temperature themselves at the height of 1.0m above the floor in the central part of the room. Generally the air conditioning was by forced warm air, and not always with humidity control. The total number of collected questionnaires was 1,030 (515 dwellings with each type of heating

system). This cross-sectional survey showed a clear preference for floor heating systems, and so it was decided to conduct further extended surveys to be accompanied by more complete and reliable measurements of the thermal environment (Rijal & Omori 2013). The purpose was to see whether these new data would confirm the preference for floor heating found in the web-survey, and if so to explain it.

2 Investigation method

2.1 Questionnaires

The questionnaires were based on the one we had developed for the web-survey, but including additional questions about humidity and overall satisfaction. The questionnaire aimed to extract any differences in thermal comfort there might be between the floor heating and air conditioning systems (Tables 1, 2 and 3).

The ASHRAE scale has been widely used, but the words “warm” or “cool” imply comfort in Japanese. The Society of Heating, Air-Conditioning and Sanitary Engineers of Japan (SHASE) therefore developed a modified form of the ASHRAE scale for Japan (Okuma et. al. 2008). To avoid possible misunderstanding of “neutral” in the thermal sensation scale, it is explained as “neutral (neither cold nor hot)” or “neutral (neither cool nor warm)”. We used both the ASHRAE scale and the SHASE scale.

Table 1. Questionnaires for thermal comfort and humidity

No.	SHASE scale Now, how do you feel the air temperature on whole body / floor temperature on feet?	ASHRAE scale Now, how do you feel the air temperature on whole body / floor temperature on feet?	Thermal preference Now, how do you prefer the air temperature on whole body / floor temperature on feet?	Humidity feeling Now, how do you feel the humidity?	Humidity preference Now, how do you prefer the humidity?
1	Very cold	Cold	Much warmer	Very dry	Much more humid
2	Cold	Cool	A bit warmer	Dry	A bit more humid
3	Slightly cold	Slightly cool	No change	Slightly dry	No change
4	Neutral (neither cold nor hot)	Neutral (neither cool nor warm)	A bit cooler	Neutral (Neither dry nor humid)	A bit drier
5	Slightly hot	Slightly warm	Much cooler	Slightly humid	Much drier
6	Hot	Warm		Humid	
7	Very hot	Hot		Very humid	

Table 2. Questionnaires for air movement and noise.

No.	Air movement feeling Now, how do you feel the air movement?	Air movement preference Now, how do you prefer the air movement?	Noise feeling Now, how do you feel the system operation noise?	Noise preference Now, how do you prefer the system operation noise?
1	Very low air movement	No change	Very quiet	No change
2	Low air movement	A bit less air movement	Quiet	A bit quieter
3	Slightly low air movement	Much less air movement	Slightly quiet	Much quieter
4	Slightly high air movement		Slightly noisy	
5	High air movement		Noisy	
6	Very high air movement		Very noisy	

Table 3. Questionnaires for overall comfort and satisfaction.

No.	Overall comfort By considering the thermal environment (air temp., humidity, air movement and others), please give the overall comfort now.	Satisfaction Now, please give the satisfaction of thermal environment (air temp., humidity, air movement and others).
1	Very comfortable	Very satisfied
2	Comfortable	Satisfied
3	Slightly comfortable	Slightly satisfied
4	Slightly uncomfortable	Slightly unsatisfied
5	Uncomfortable	Unsatisfied
6	Very uncomfortable	Very unsatisfied

Table 4. Description of the investigated buildings.

Building name	Constructed year	Number of houses	Number of investigated houses	
			First period	Second period
A	2006	1036	25	20
B	2003	989	-	5

The investigation was conducted in the living rooms of 50 apartment houses of two reinforced concrete buildings (Table 4) in Tokyo for two periods each of two-weeks, January 30th to February 12th (first period) and February 15th to 28th (second period)). In each two-week period, we investigated 25 households, using floor heating for one week and air conditioning for the other. The chosen dwellings had both system-types installed. To give a similar variation in outdoor temperature within a group, 12 houses used floor heating and 13 houses used air conditioning in first week, and vice versa in second week. These procedures were repeated in the second two-week period. The air temperature, globe temperature and relative humidity were measured at the height of 0.6 m above the floor in the central part of the living room (Fig. 1). Floor temperature was measured at the centre of the living room by sticking a sensor to the floor surface with surgical tape (Fig. 1). The data were recorded automatically at 10-minute intervals. Meteorological data was obtained from the nearest meteorological station.

Fifty men and fifty women (husbands and wives) took part in the surveys. They gave their responses several times in a day, and we have collected more than 6000 completed questionnaires. Sometimes residents used other heating equipment in addition to the floor heating or the air conditioning heating. We have analysed only the data where no additional equipment was in use.

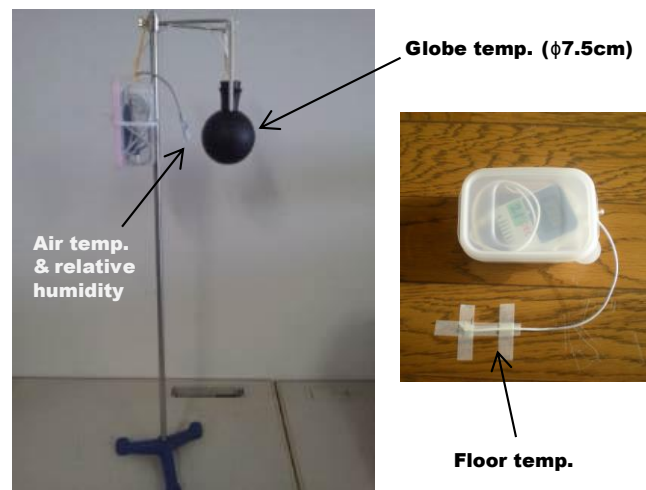

Fig. 1 Details of the thermal measurement

3 Results and Discussion

3.1 Temperature

Outdoor Air temperatures:

The mean outdoor air temperature for the floor heating mode was 5.7 °C and the relative humidity 49%. For the air conditioning mode they were 5.9 °C and 47%. The outdoor temperature and humidity can therefore be considered to be the same for both heating modes.

Indoor temperatures:

The distribution of indoor air temperature, globe temperature and floor temperature are shown in Figs. 2 & 3. The mean indoor air temperature and its standard deviations for the two types of heating were virtually identical in the two modes of operation. The same is true of the globe temperatures. The indoor temperatures can therefore be regarded as the same for both modes. The mean floor temperature for the floor heating mode was 4.7 °C higher than for the air conditioning mode (Fig. 3(b)).

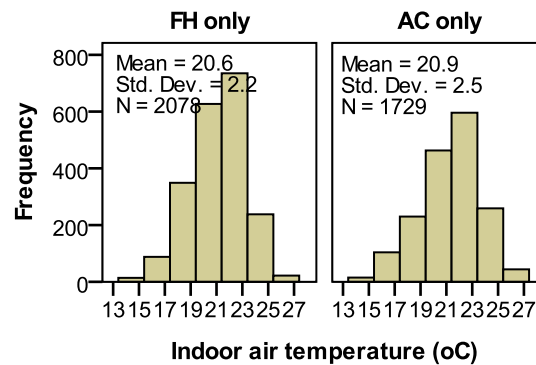

Fig. 2 Distribution of air temperature at the time of voting.

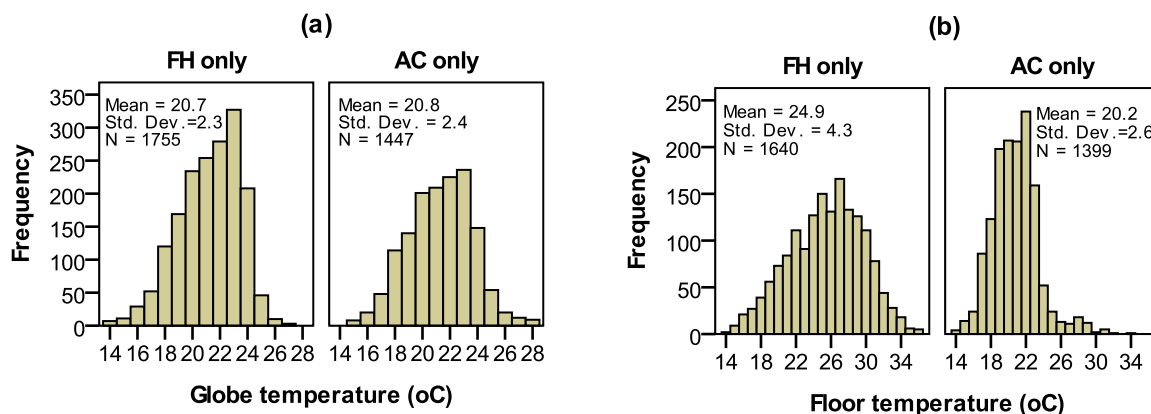

Fig. 3 Distribution of globe temperature and floor temperature at the time of voting.

3.2 Evaluation of thermal sensation of the whole body

From the web survey, which had a large arguably random sample of people, we had concluded that the SHASE scale was better than the ASHRAE scale, having more uniform psychological widths of its scale-categories, and its ‘neutral’ category being close in meaning to the ‘prefer no change’ category on the thermal preference scale. We have therefore chosen it for the analysis of the present data.

The Fig. 4(a) compares the distribution of the thermal sensation on the SHASE scale for the two modes, with the 95% confidence intervals of the percentages shown. The mean thermal sensation of the SHASE scale for floor heating is 0.1 higher than the air conditioning – a very small difference. However, the proportion responding “4 neutral” for the floor heating mode is higher than for the air conditioning mode. The proportion responding “3 slightly cold” for floor heating is also lower than for the air conditioning.

A very similar picture is evident from the question about thermal preferences (Fig. 4(b)). With floor heating more people say they desire no change in their warmth sensation, and fewer say they would prefer to be warmer. The results showed that the residents who used floor heating felt slightly more thermally comfortable in the whole body compared with the residents who used air conditioning.

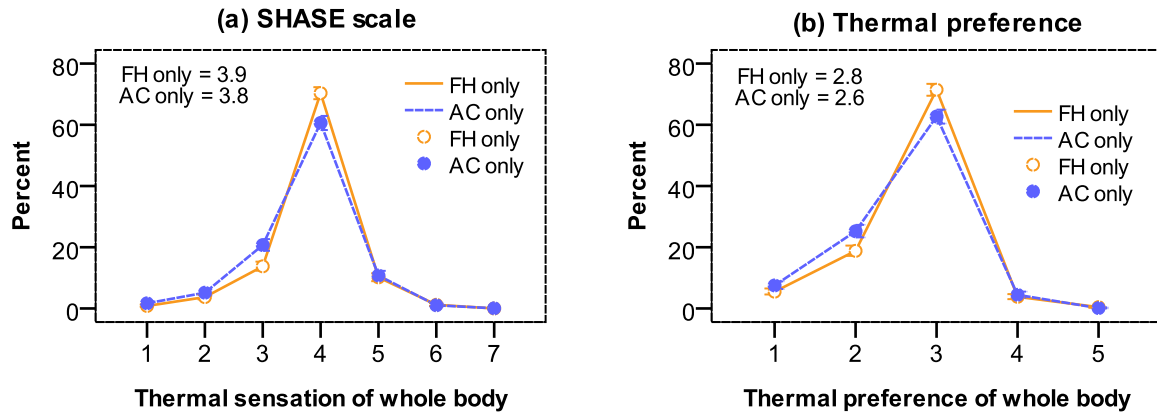

Fig. 4 Comparison of thermal sensation and thermal preference for the two modes

3.3 Evaluation of the thermal sensation of the feet

Fig. 5(a) shows the distribution of the thermal sensation of the feet, with the 95% confidence intervals of the percentages. The mean thermal sensation of the SHASE scale for floor heating is about 1 scale unit warmer than the air conditioning – a substantial difference. The proportion of “4 neutral” for floor heating is much higher than the air conditioning, while the proportion of “3 slightly cold” for floor heating is much lower than with the air conditioning. The residents were less likely to have cold feet with the floor heating. Despite the similarity in the overall subjective warmth for the two modes, as shown in Fig. 5(a), there was a large difference in the thermal sensation of the feet.

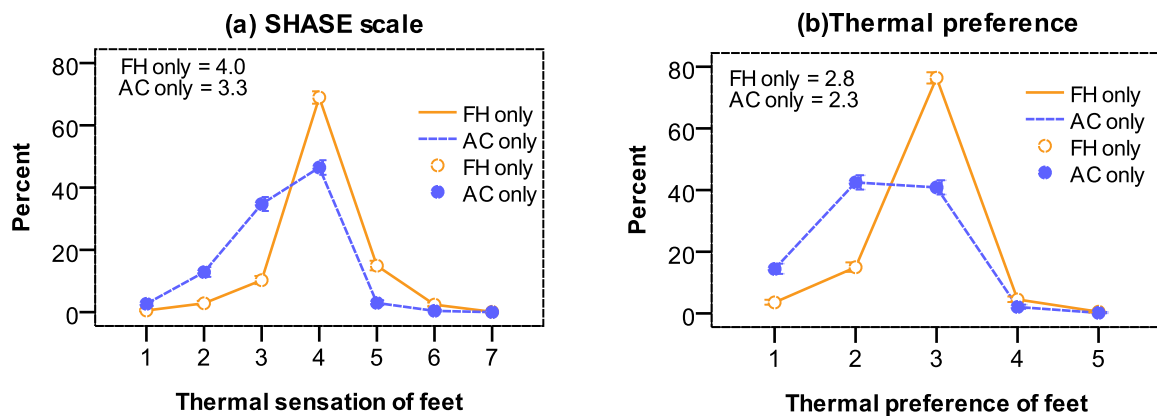

Fig. 5 Distribution of thermal sensation and thermal preference for the feet.

It may be wondered whether people liked their feet to be warm. That this was so can be found from the distribution of thermal preference for the feet. The mean thermal preference for the feet is half a scale unit higher with floor heating – a considerable advantage. The improvement is statistically significant ($t=24.4$, $p<0.001$). The proportion who desired no change in the thermal sensation of the feet was very much higher with the floor heating (Fig. 5(b), while far fewer would prefer their feet to be warmer. The floor heating reduced the incidence of people wanting their feet to be warmer without much increasing the few who wanted their feet to be cooler. So the feet were much more comfortable with floor heating.

3.4 Evaluation of humidity

Although the actual indoor humidity was virtually the same for the two types of system, the homes using floor heating were perceived to be rather more humid than those using AC. The distribution is shown in Fig. 6(a) (the ‘humidity feeling’). That they preferred this condition is revealed by the humidity preference distribution (Fig. 6(b)). Many more people were pleased with the humidity with the floor heating.

It is well known that subjective perceptions of humidity do not map well onto actual humidities. People are not equipped with humidity sensors, so the perceived humidity is a mental construct, and may be but slightly to humidity as a physical measurement. So the subjective humidity relates to something other than the measured humidity of the environment, perhaps to the amount of airborne dust, which can produce irritation in the eyes and throat be interpreted as ‘dryness’. Whatever the reason may be, our respondents preferred the ‘humidity’ in the rooms with floor heating. The meaning of subjective humidity requires further research.

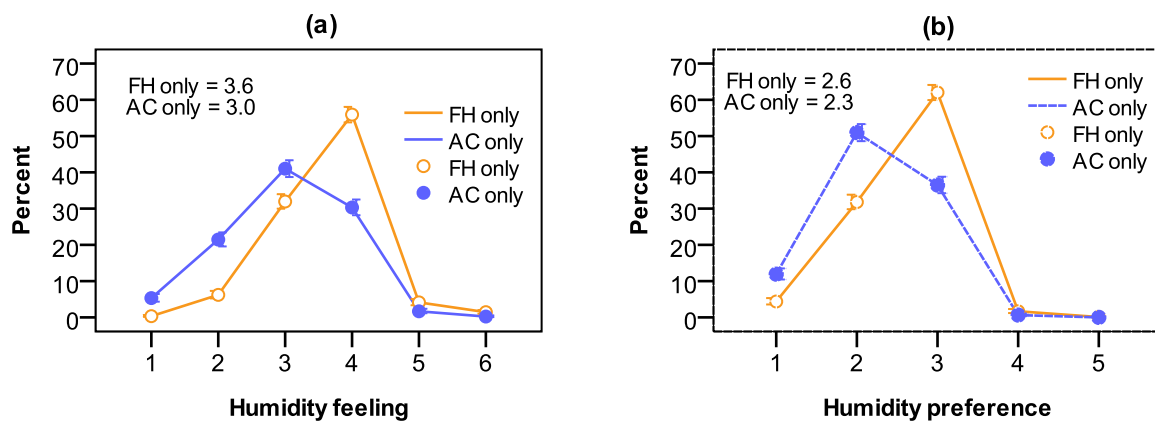

Fig. 6 Assessments of humidity

3.5 Evaluation of air movement

The air movement was evaluated for the floor heating and for the air conditioning modes. An air-conditioning system is fan-driven, and this is likely to increase to some extent the air movement within the room. Air speed was not measured, but our respondents perceived the air movement to be greater in the AC mode. Fig. 7(a) shows the distributions of the air movement sensations, with the 95% confidence intervals of the percentages.

The mean air movement feeling for floor heating was about 1.6 scale units less – a very large difference ($t=49.2, p<0.001$). Notably the proportion who felt no air movement (“1 not felt”) was very much higher for floor heating than with air conditioning.

But did they like the absence of a sense of air movement? The mean air movement preference for floor heating and air conditioning were significantly different ($t=31.6, p<0.001$). The proportion who desired no change in their sensation of air movement (“1 no change”) for the floor heating mode is far higher than the air conditioning (Fig. 7(b)). Nearly everyone with floor heating liked the lack of perceived air movement, wanting no change, while this percentage fell to some 60% in the AC mode.

The results show that floor heating was preferred to the air conditioning from a viewpoint of perceived air movement.

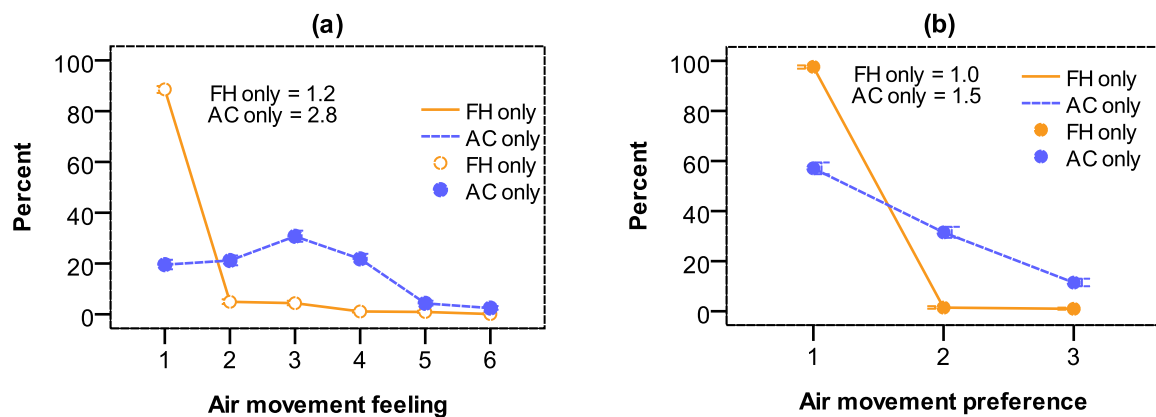

Fig. 7 Distribution of perceived air movement and air-movement preference.

3.6 Evaluation of system noise

A floor heating system is silent, while an AC system has some noise from the fans in the ducting. The difference proved very noticeable to the occupants, as can be seen at once from Fig. 8(a). The preference scale shows that 50% of those in AC rooms would have liked it ‘a bit quieter’ or ‘much quieter’. In the floor heating mode everyone was content with the lack of noise, 100% desiring ‘no change’ (Fig. 8(b)).

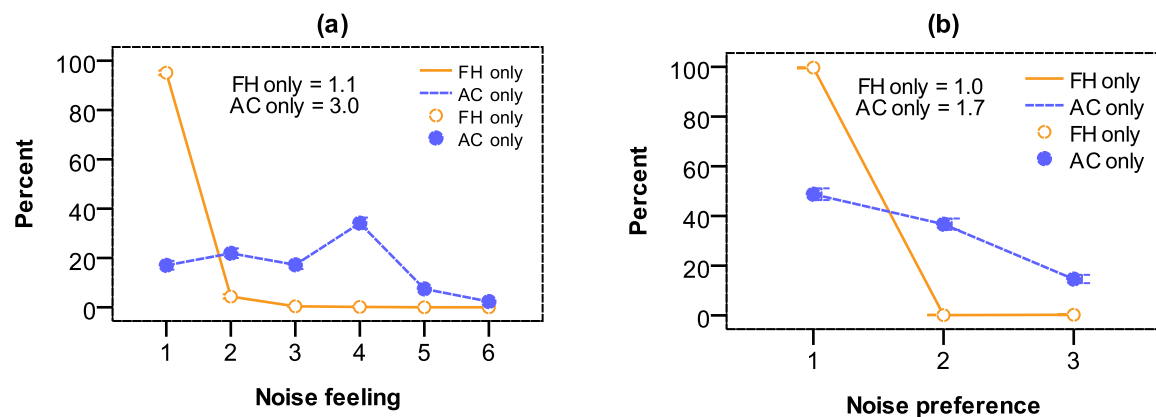

Fig. 8 Evaluation of system-noise

3.7 Evaluation of overall comfort and satisfaction

The overall comfort of residents was evaluated. Fig. 9 shows the distribution of overall comfort for the two modes, together with the 95% confidence intervals of the percentages. The mean overall comfort of the floor heating mode was substantially higher than for the AC mode (3.1 compared with 2.6). The difference statistically significant ($t=18.0$, $p<0.001$). The proportion responding “2 comfortable” was considerably higher with floor heating than with air conditioning. This agrees with the result of the question about how satisfied they were (Fig. 10). The clear advantage was with the floor heating systems.

The results showed that the thermal satisfaction of the floor heating was higher than with the air conditioning.

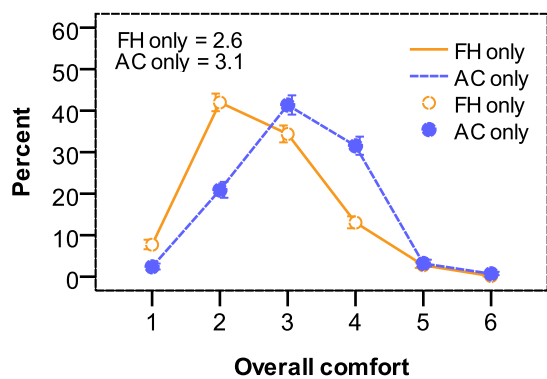

Fig. 9 Comparison of overall comfort

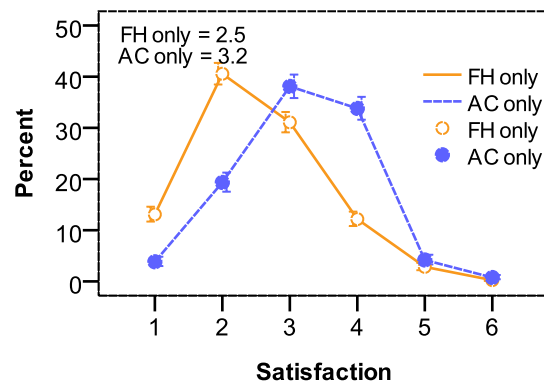

Fig. 10 Comparison of satisfaction

4 Conclusions

The measurements of the thermal environment demonstrated that the two modes did not differ appreciably in their indoor and outdoor temperatures during the periods of the survey, except of course that the floor was warmer with floor heating. The virtual equality of indoor and outdoor temperature in the two modes enabled us to directly compare the subjective responses for the two modes.

There was no practical difference in the overall sensation of warmth between the two modes, the floor heating and the air conditioning being perceived at equally warm. However, the more detailed questions all revealed a preference for the floor heating mode, confirming the finding of our earlier web survey.

With floor heating fewer people desired any change in their overall sensation of warmth. Their feet were warmer, and this they welcomed. They assessed the space as more humid, and they preferred it to be so, though the reason for the different assessment is uncertain. They perceived less air movement in the floor heating mode, and this they preferred. They liked the lack of noise with floor heating. Finally they rated themselves as more comfortable and more satisfied overall.

The subjective advantage of floor heating compared with AC for winter heating for this sample of people in the living room of their dwellings is therefore clearly revealed.

References

1. Emoto K., Matsumae K., Akimoto T., Kuwasawa Y., Emura K. 2009. Equivalent condition for various heating systems: Investigation with subjective and thermal manikin experiment results, *Summaries of Technical Papers of Annual Meeting of SHASE*, F-37, pp. 1307-1310 (in Japanese).
2. Griffiths I.D.1990. Thermal comfort in buildings with passive solar features: field studies. Report to the Commission of the European Communities. EN3S-090 UK. University of Surrey, Guildford, UK.
3. Kagiya S., Matsumae K., Inagaki K., Kawamata D., Akimoto T., Kuwasawa Y. 2007. Evaluation of thermal comfort for various heating systems: Part 1 an analysis of questionnaire survey result concerning heating apparatus use. *Summaries of Technical Papers of Annual Meeting of SHASE*, pp. 449-452 (in Japanese).
4. Matsumae K., Kagiya S., Inagaki K., Kawamata D., Akimoto T., Kuwasawa Y. 2007. Evaluation of thermal comfort for various heating systems: Part 3 measurement of thermal comfort and skin temperature. *Summaries of Technical Papers of Annual Meeting of SHASE*, pp. 457-460 (in Japanese).
5. Nicol F., Jany G.N., Sykes O., Humphreys M., Roaf S., Hancock M. 1994. A survey of thermal comfort in Pakistan toward new indoor temperature standards. Oxford Brookes University, School of Architecture, UK.
6. Okuma R, Ishino H, Nakayama S. 2008. Clothing and thermal comfort at 20°C of air temperature in winter, *J. Environ. Eng., AIJ, Vol. 73 No. 625*, pp. 307-312 (in Japanese with English abstract).
7. Rijal H.B., Tuohy P., Humphreys M.A., Nicol J.F., Samuel A., Raja I.A., Clarke J. 2008. Development of adaptive algorithms for the operation of windows, fans and doors to predict thermal comfort and energy use in Pakistani buildings. *ASHRAE Transactions 114(2)*, pp. 555-573.
8. Rijal H.B., Omori T. 2011. Evaluation of thermal comfort of floor heating and air conditioning in residential environments. *Summaries of Technical Papers of Annual Meeting of SHASE*, C-56, pp. 1849-1852 (in Japanese).
9. Rijal H.B., Toshiaki Omori T., Humphreys M.A., Nicol J.F. (2012), Evaluation of the thermal comfort of floor heating systems and air conditioning systems in Japanese homes, *The 5th International Building Physics Conference (IBPC)*, pp. 1005-1010, 28-31 May, Kyoto Japan.
10. Rijal H.B., Omori T. 2013. Study on the thermal comfort of floor heating systems and air conditioning systems in apartment houses. *Summaries of Technical Papers of Annual Meeting of SHASE*, Vol.6, F-47, pp. 133-136 (in Japanese).
11. Tobita K., Matsubara N., Kurazumi Y., Nakaya T. and Shimada R. 2009. Difference of the thermal sensation votes by the scales in the field survey of houses during winter. *J. Environ. Eng., AIJ, Vol. 74 No. 646*, pp. 1291-1297.

Personal heating; energy use and effectiveness

J. Verhaart¹, M. Veselý¹, S. Kik, W. Zeiler¹

1: Department of Built Environment, Eindhoven University of Technology, Netherlands

Abstract

Increasing personal comfort by heating office building occupants locally means that the lower setpoint for space heating. Less energy will be used when the total energy demand from all individual comfort systems together is lower than the energy saved by lowering the setpoint. The energy saving potential is dependent on the specific characteristics of the individual heating. The important performance characteristics are the energy used per unit of mitigated discomfort and the maximum discomfort that can be compensated for. A pilot study was conducted to investigate these performance indicators. Three methods for locally heating the hands were compared on effectiveness and energy use. The methods were a heated desk mat and two types of IR radiation lamps, all heating the hands. All were found to be effective, however, there was a clear difference in speed for compensating discomfort.

Keywords: personal comfort, thermal comfort, individual heating

1 Introduction

Comfort of all occupants in an office building can be improved using a small climate system at each desk that is able to heat or cool the individual occupant working there. Applying such a system has the potential to reduce the energy consumption of the whole building as well. Since an extra level of climate system is added, energy reduction is not a given.

In this paper, a strategy is presented that can be used to determine the energy saving potential of an Individual Comfort Systems (ICS) providing local heating, applied in a normal office building. A set of criteria can be formulated and performance indicators can be defined. That provides a guideline for the design of new ICSs and for the evaluation of these systems.

An ICS for heating consists of one or several small heaters that can heat specific parts of the body. That is enough to compensate for whole body discomfort and increase their overall thermal sensation (TS) (Watanabe, Melikov, & Knudsen, 2010). With the application of an ICS for all workplaces in an office building, the use of the central climate control system is partly replaced. When comfort can be provided for every person in the room individually, it provides each individual with influence on their environment and individual differences in preferences can be solved.

Earlier studies, (Boerstra, 2010) for example, have shown that the tolerance for environmental conditions in a room is strongly related to the amount of people in the room and the influence a person perceives to have on the environment. From a comfort perspective, applying an ICS is an improvement, however, adding an extra layer of system in a building could lead to extra energy use.

Using ICSs has to potential to reduce energy consumption. This is due to the following characteristics. The fact that the energy is used close to the person, so it affects a small area of the office, that the system is only used if someone is present and when this person is feeling uncomfortable.

The performance characteristics of an ICS determine the energy saving potential. The performance of an ICS is measured in the energy that is needed for the mitigation of a certain level of discomfort. An ICS has a limit in the level of discomfort that can be compensated for, because only parts of the body are heated. A large difference in temperature between body parts is also considered uncomfortable.

Methodology

Energy consumption can be reduced when the discomfort introduced by lowering the set point for heating can be compensated for by the ICSs more efficiently. As shown in formula (1), the energy use at the high set point of central heating (CH) should be higher than the energy use at lower set point plus the energy use of all ICSs that are turned on. The new set point of the central heating is highly dependent on the characteristics of the building itself, the climate system, the amount and density of the occupants and the performance characteristic of the ICS

$$E_{CH \text{ high setpoint}} \geq E_{CH \text{ low setpoint}} + \sum E_{ICS} \tag{1}$$

The strategy for finding the energy reduction potential of an ICS in a specific building starts with finding the ideal set point for the CH. Therefore, the energy use of the building is determined. The thermostat setting is connected to the room temperatures, than the Predicted Mean Vote (PMV) can be calculated. The Actual Mean Vote (AMV) can also be determined through questionnaires. The typical energy use of the CH is calculated from the measured energy use over a year and the degree days of the same year. This way, the energy reduction of lowering the thermostat setting can be calculated. The reduction of the PMV is to be determined as well.

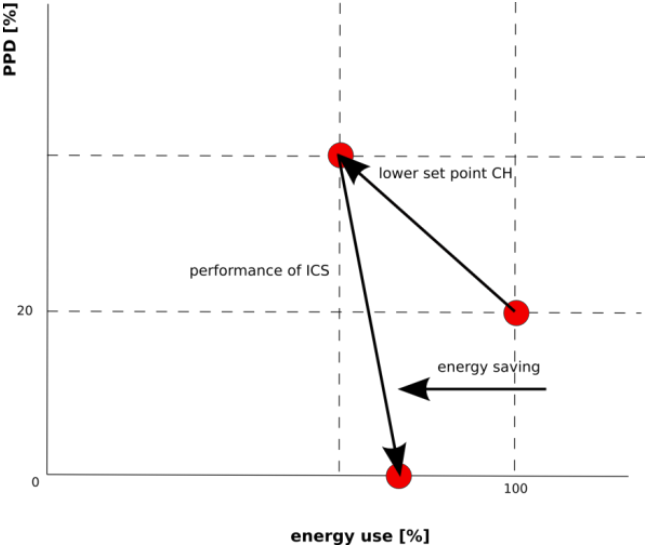

Figure 1: Strategy for reducing energy consumption and increasing comfort level in an office building: first lower setpoint of thermostat, reducing comfort level, then introduce ICS

The other factors determining the energy reduction potential are the performance characteristics of the ICS and the translation of the performance of one ICS to a whole building of ICSs. Lowering thermostat setting means reduction in PMV for the whole building and increase of

Predicted Percentage Dissatisfied (PPD). The PPD can be used as a measure for the number of people that turn on their ICS. The setting is harder to estimate, one only knows that there will be people who are dissatisfied, we don't yet know how much.

On an individual level, one can expect a dissatisfied person to turn on the ICS. The system will remain turned off for people that are not dissatisfied. The PMV/PPD relation shows that even with a $PMV = 0$, 5% of the building occupants can be expected to be dissatisfied with the local climatic conditions (Fanger, 1970). This means that in a neutral environment, one can expect that 2,5% of the people are too cold and have the ICS turned on.

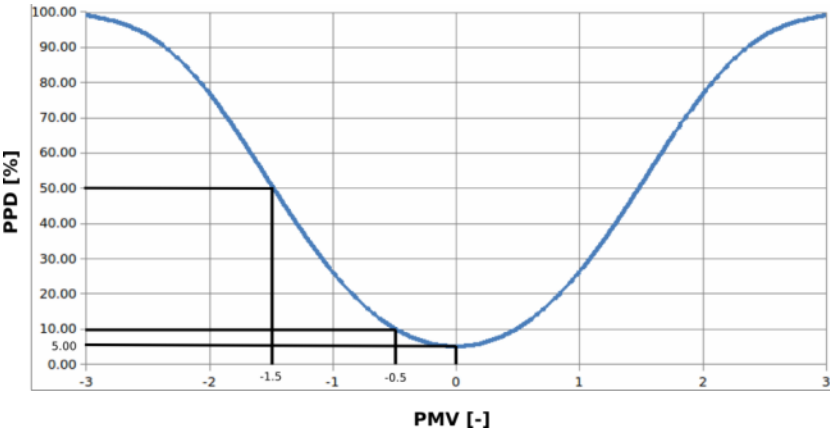

Figure 2: PMV/PPD curve, the PPD at $PMV = 0$ is still 5%, the PPD in a well-acclimatized building is between 5% and 10%. Experiments are conducted at $PMV = 1.5$ with expected PPD of 50% (Fanger, 1970)

A pilot study is done for determination of the performance and energy saving potential of several different parts of an ICS. For this pilot, four subjects were tested in the climate room. The room was set at a constant $18^{\circ}C$ ($PMV = -1.5$, $PPD = 50%$ at 1.0 clo). Three different methods of local heating of the hands were compared. The three methods for heating were: contact heating by heating the desk (heating the hands from below), and heating the hands from above using two different IR lamps, one with a visible red glow and the other one with a ceramic housing that only emits heat in the invisible IR spectrum.

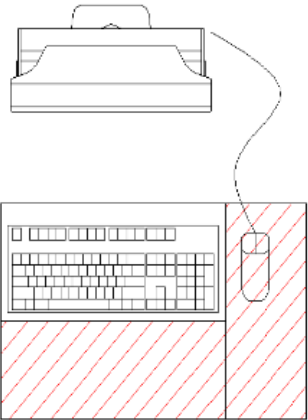

Figure 3: lay out of the heating panels around the keyboard of the computer



Figure 4: Two types of IR lamps used in the pilot experiment, White IR on the left, red IR on the right Table 1: Power of the heaters used in the pilot experiments

	Heater	Power
1	2 Desk heating panels	2x 12 W
2	2 IR heating red light (red IR)	2x 100 W
3	2 IR heating lamp (white IR)	2x 60 W

The tests lasted until all three heaters were tested. The test subjects were acclimatized to the cold, before each test. When people were reporting that they had reached a thermal sensation of -1.5, a hand heater was started. When the subject reported that he or she was neutral or comfortable again, the heater was turned off and the subject was left to cool again. This procedure was repeated for all heaters.

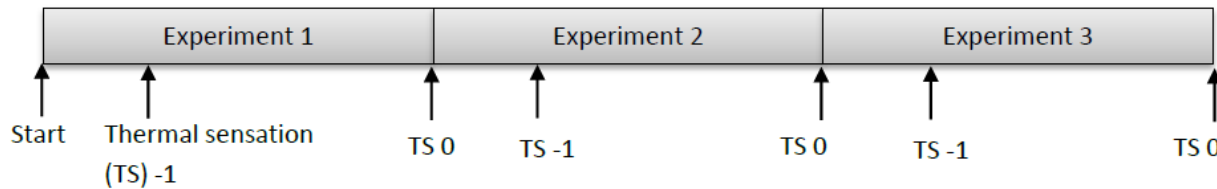

Figure 5: Experimental set up, timing is based on the thermal sensation of the test subjects.

During the test, the subjects wore 7 iButtons to measure the skin temperature. The iButtons were placed on the finger, wrist and lower arm, both left and right and one in the neck. A thermal camera is used to monitor the finger temperature. This way, the use of thermal images to determine comfort level based on fingertip temperature can be tested as well.



Figure 6: test set up in the climate chamber

Results

We have found that it is possible to increase the overall TS of an individual person using a local heating of the hands. All hand heaters managed to mitigate the discomfort within a relatively short time. The average recovery times are shown in Figure 7.

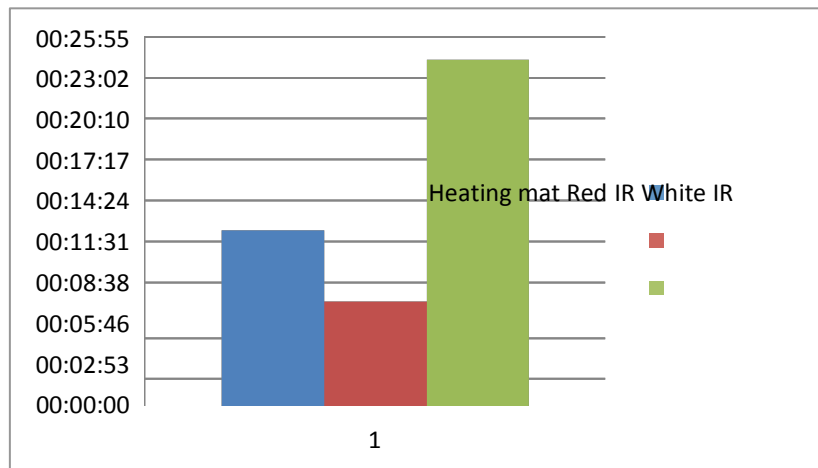

Figure 7: recovery times of different heating methods

The modes of heating have an impact on the possibility to track the fingers from the IR image. The finger is easier to track if the temperature difference is larger. On the images in Figures 8 through 10.

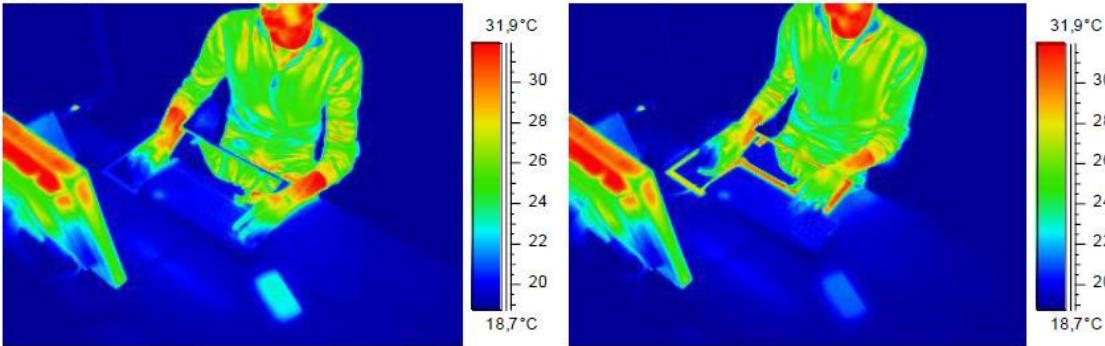

Figure 8: The desk heater tuned off (left) and on (right). The fingers are cold already, but wrist and arm still comfortable.

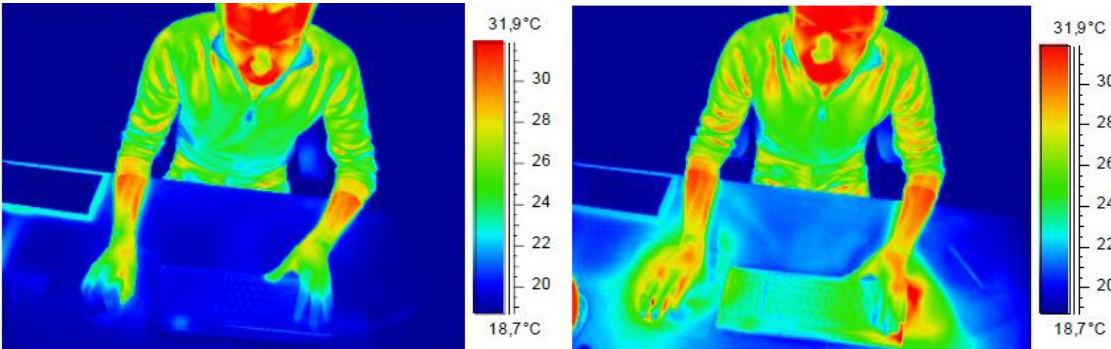

Figure 9: Effect of heating using the White IR lamps

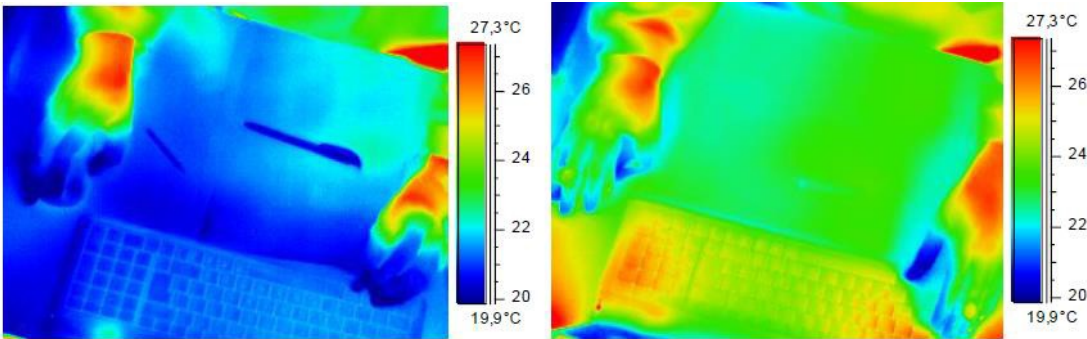

Figure 10: Effect of heating using the red IR lamps

Discussion

Even though during the experiments the focus was on removing existing discomfort, there was a clear distinction between the heating methods. The heaters used at maximum power when turned on, which would lead to a large overshoot in a real office environment. Ideally, the system would be turned on at emerging discomfort and the setting would be changed when needed. In later tests we found that people tend to be more cautious in choosing the setting and adjust the setting when comfort is reached.

Drawbacks come of the systems tested use direct electrical resistance heating. This choice is made because the devices are small, inexpensive, widely available and flexible. However, electricity is a high quality energy and has a high primary energy use. Higher than comparable room heating systems, usually based on gas fired boilers. The use of electricity could be compensated for by using Photo-Voltaic panels on the building.

Habituation to turning on the system is a risk. People could, after getting used to the system, dress for this extra heat provided by the system. Increased clothing level is still a more energy efficient method of increasing thermal sensation.

Further research

The energy saving potential of an office building equipped with ICSs can be further increased with a number of additional measures. Lower set points of the thermostat for the building climate system will reduce the required capacity of the heating system, which in turn would increase the systems efficiency.

The method of simply reducing the set point of the global heating system could be abandoned when the comfort level of individual users can be determined, either through combining the voting or through remote objective measurement. The global system would be engaged only when the energy use of all the local systems individually would exceed the energy use of the global system for increasing the room temperature or the discomfort that is to be mitigated is greater than the ICS is able to provide.

Even more energy can be saved when the global climate system in a building and the ICS fully cooperate with the local systems, when information is exchanged on the settings of the system, local environmental conditions and self-reported and possibly objective measured information on the comfort level of the individual workers.

The psychological effects of using local heating systems rather than what people are used to are not yet known. Before these systems become commonplace in the office, these factors are to be studied. As mentioned above, the effect of having direct influence on the climatic conditions on the workplace could be positive in that people become more tolerant compared to same size office spaces of the environmental conditions. This would allow a further increase in range of environmental conditions where the building can be kept free running.

Using an objective way of determining the comfort level of the occupants in addition to the user controls can lead to a reduction in energy use of the ICS, because it can start reducing power once comfort is restored and continuously adjust to stay within the TNZ in the most efficient manner. People are likely to wait before adjusting the system until it becomes uncomfortable on the other end of the TNZ. With the inclusion of comfort detection, the comfort level of the occupants and the energy use of all ICSs can be leading in controlling the ICS and the global climate system.

References

Boerstra, A. C. (2010). Personal control in future thermal comfort standards. ... *TO CHANGE: NEW THINKING ON COMFORT*, ..., (April), 9–11. Retrieved from [http://www.taskair.net/I want to know more/Personal control in future thermal comfort standards.pdf](http://www.taskair.net/I_want_to_know_more/Personal_control_in_future_thermal_comfort_standards.pdf)

Fanger, P. O. (1970). *Thermal Comfort, Analysis an Applications in Environmental Engineering*. Copenhagen, Denmark: Danish Technical Press.

Kellogg, D. (2006). In vivo mechanisms of cutaneous vasodilation and vasoconstriction in humans during thermoregulatory challenges. *Journal of Applied Physiology*, *100*(5), 1709– 1718. doi:10.1152/jappphysiol.01071.2005

Watanabe, S., Melikov, A. K., & Knudsen, G. L. (2010). Design of an individually controlled system for an optimal thermal microenvironment. *Building and Environment*, *45*(3), 549– 558. doi:10.1016/j.buildenv.2009.07.009

Cross-Correlations among daily variations of Thermal Control Use, Thermal Sensation, Clothing Insulation and Outdoor Temperature during Cooling Season in Japan

Noriko Umemiya¹ and Tomohiro Taniguchi¹

¹ Graduate School of Engineering, Division of Architecture, Osaka City University, Osaka, Japan, umemiya@arch.eng.osaka-cu.ac.jp;

Abstract

This survey was designed to investigate university student rooms to realize energy savings related to thermal control use and the relations among thermal sensation, clothing insulation, and outdoor air temperature in pre-cooling and post-cooling seasons. Results revealed the following: 1) Phase shifts to the outdoor air temperature mutually differ in pre-cooling and post-cooling seasons. 2) For neutral temperatures, although the effect of pre-cooling makes the act of opening a window less likely, that is not true in the post-cooling season. 3) For thermal sensations, the section rates of thermal control use vary in the pre-cooling season, but do not vary in the post-cooling season. 4) The clothing amount varies more during the pre-cooling season than during the post-cooling season.

1 Introduction

The saturation level of air-conditioner use for cooling reached 90.0% in households in Japan in 2012. An average 3.0 air-conditioners are used per domicile. The figures include cooler summer districts such as Hokkaido and Tohoku, which receive much snow during winter. It is not unusual that households have an air-conditioner for every room in the central area of general climate in Japan.

Sakane et al. (2012), however, reported that people do not necessarily depend on air-conditioners to cope with summer heat. The survey shows that 15.6% ‘Very frequently’, 45.1% ‘Frequently’, 26.6% ‘Occasionally’ and 10.4% ‘Rarely’ use air-conditioners for cooling in residences. 67.2% answered ‘I usually keep windows open in my house during the daytime in summer’. 41.2% responded that ‘I usually keep windows open in my house when sleeping in summer’. Furthermore, 10.0% chose ‘I can bear summer heat in my house only by natural ventilation’, whereas 65.1% chose ‘I can bear summer heat in my house using air-conditioners occasionally’. Surprisingly, only 24.9% chose ‘I cannot bear summer heat in my house without air-conditioners’ in a survey of 313 apartment residents in Osaka, Japan.

People do not necessarily want to use air-conditioners. They prefer to open windows instead of using air-conditioners, although the daily maximum air temperature sometimes exceeds 35°C in Osaka. Comparison to another survey by Rin et al. (2005) for similar districts reveals that the rate of satisfaction for air-conditioners was 66.8% in 2004. That rate in a survey conducted by Sakane et al. was 79.6% in 2011. Despite improvement according to the development of air-conditioners in terms of both electricity cost and thermal comfort, Miyata et al. (2012) found that various traditional measures such as sprinkling water in the garden, paper fans, bamboo blinds, and cool clothing or bedding are still used to bear the heat.

Umemiya et al. (2006) recorded both window opening and air conditioner use along with indoor thermal environment in apartment houses. They demonstrated the limit outdoor temperature of natural cooling by window opening and modelled a relation between the ratio of air-conditioner use and indoor and outdoor temperatures. Asawa et al. (2005) measured both window opening and air conditioning use in detached houses in summer. Their results showed that the outdoor wind environment affected window opening and predicted air conditioner use under specific air temperature conditions. This study examined daily records of both window opening and air conditioner use during pre-cooling and post-cooling seasons. Moreover, thermal sensations in indoor and outdoor and clothing were recorded. The subjects of the study were university students. The thermal environment was measured in laboratory rooms.

2 Methods

2.1 Measurements and observations

University laboratory rooms are spaces where students spend almost all of their time from early morning to late evening. Students select clothing, open windows, and change air-conditioner setting temperatures as they like without payment of an energy charge. Indoor air temperatures and humidity, and outlet air temperatures of the air conditioners were recorded in 28 laboratory rooms from the second to fifth floor in two university buildings at intervals of 30 min during May–November. Rooms with temperature control for special experiments were excluded. Only rooms occupied by students were chosen.

States of window opening were recorded by observations conducted from outside of the buildings at around 10:30 and 16:10 during Monday–Friday for all windows of the buildings. There were 352 windows on one side of the building. Three sides were examined, as Figure 1 shows. The opening ratio to the maximum opening area was recorded at five degrees. The observers were students occupying the measured rooms. The observation took about ten minutes. Observers also recorded their indoor and outdoor thermal sensation in the ASHRAE scale, thermal comfort using a four point scale, in addition to humidity sensation and clothing ensembles at the same time as the window observations. The outdoor air temperature, humidity, solar irradiance, wind velocity, and direction were measured at intervals of ten minutes on the rooftop of the neighbouring building.



● : outdoor measurement point

Windows of thick lined sides were observed.

Figure 1. Plan of the buildings and picture of the north elevation of Building-C.

2.2 Definitions of ratio of air-conditioner use and ratio of opening

Air conditioner use was judged from the difference of indoor and outlet temperatures. The ratio of air conditioner use was defined as the ratio of the number of air-conditioned rooms to all measured rooms for three records before and after the window observation time. The ratio of opening is defined as the ratio of opening area of all student room windows against the full open area.

2.3 Definitions of seasons

Figure 2 shows the daily variation of the ratio of air conditioner use averaged for morning and afternoon. The ratio begins to increase from mid-May. The period before June 2 is defined as the ‘spring natural ventilation season’ when the daily mean number of air-conditioned rooms is less than 1.5. The period between June 3 and June 22 is defined as the ‘early cooling season’ until the use ratio reaches 0.5. The period between June 23 and September 21 is defined as the ‘cooling season’ when the use ratio is higher than 0.5. The period between September 22 and October 3 is defined as the ‘late cooling season’ when the number of air-conditioner use is greater than two. The period between October 4 to November 7 is defined as the ‘autumn natural ventilation season’ because 9 of the 28 rooms began to use heaters from the week of November 7. In this study, the spring natural ventilation season and early cooling season are collectively designated as the pre-cooling season. The late cooling season and autumn natural ventilation season are collectively designated as the post-cooling season.

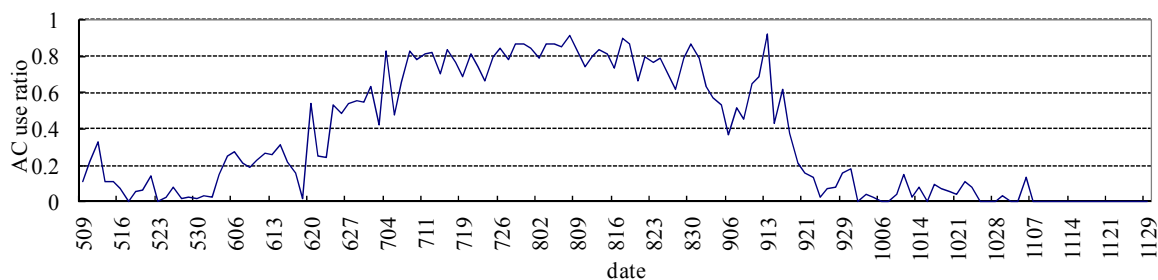

Figure 2. Daily variation of air-conditioner use ratio.

2.4 Data preparation to assess the phase difference

Raw data acquired twice a day were averaged for the day, except for failed measurements. Daily data were averaged for a week. In this study, weekly variations of thermal environment, thermal control use, thermal sensation and clothing insulation were standardized for mutual comparison. In equation form, standardized values z_n are the following.

$$z_n = \frac{(u_n - \bar{u})}{s} \quad n = 1, 2, \dots, N \quad (1)$$

In those equations, N stands for the number of data samples. u_n are the original data values. \bar{u} signifies the sample mean. s denotes the sample standard deviation. The sample mean of z_n is zero. The sample standard deviation is unity.

3 Weekly variations

3.1 Variations of outdoor thermal environments

Figure 3 shows weekly variations of outdoor thermal environments. Outdoor thermal environments were measured at intervals of 10 min and were averaged for 1 h before and after the observation. The metabolic rate for SET* is presumed as 1.5 for conditions of standing and walking slowly. The clothing insulation was estimated according to ISO9920-1995. Indoor clothing was the same as outdoor clothing in almost all cases.

The outdoor temperature increases steeply during the rainy season of May 26 – July 8. After the season it becomes stable at high values of nearly 30°C. It begins to decrease from September to the end of the survey with the decreasing gradient lower than when it increases.

The outdoor humidity ratio is higher in summer and lower in pre-cooling and post-cooling seasons. The data vary similarly to those of the outdoor temperature, although outdoor relative humidity is almost constant for the survey period.

No particular tendencies are apparent for variations of solar irradiance or wind velocity. The variation of outdoor SET* is similar to that of outdoor temperature.

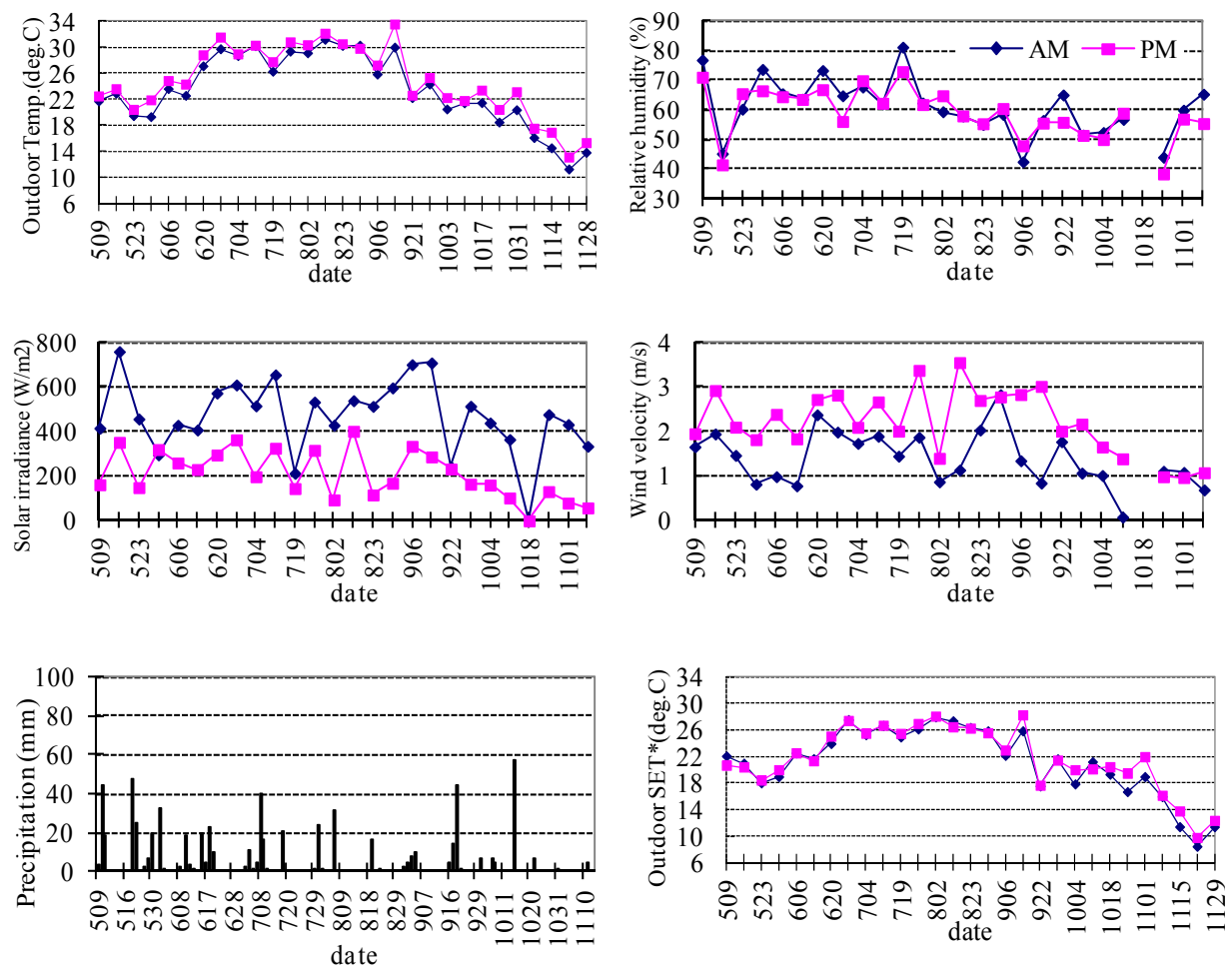

Figure 3. Weekly variations of outdoor thermal environments.

3.2 Variations of indoor thermal environments

Figure 4 shows weekly variations of indoor thermal environments. Indoor air temperature and humidity values were the averages of measurements for 28 rooms. Indoor wind velocity was not measured in this survey, but it was presumed to be 0.2 m/s for 22 rooms without electric fans and 0.8 m/s for six rooms with electric fans until the beginning of October.

The indoor air temperature was maintained at around 27°C from the beginning of July to mid-September, probably because of air conditioning. It begins to decrease since mid-September at an almost uniform gradient to the end of the survey. Both the indoor relative humidity and the humidity ratio vary similarly to the indoor temperature. The indoor relative humidity falls less than 40% from October.

Indoor SET* in rooms with an electric fan varies around 24°C. From July through September, it is about 3° cooler than in rooms without electric fans.

If indoor temperatures are compared according to the direction of the rooms' facing, either north or south, little difference is apparent until late September, but from October, temperature in rooms facing south are about 1 degree higher than in rooms facing north.

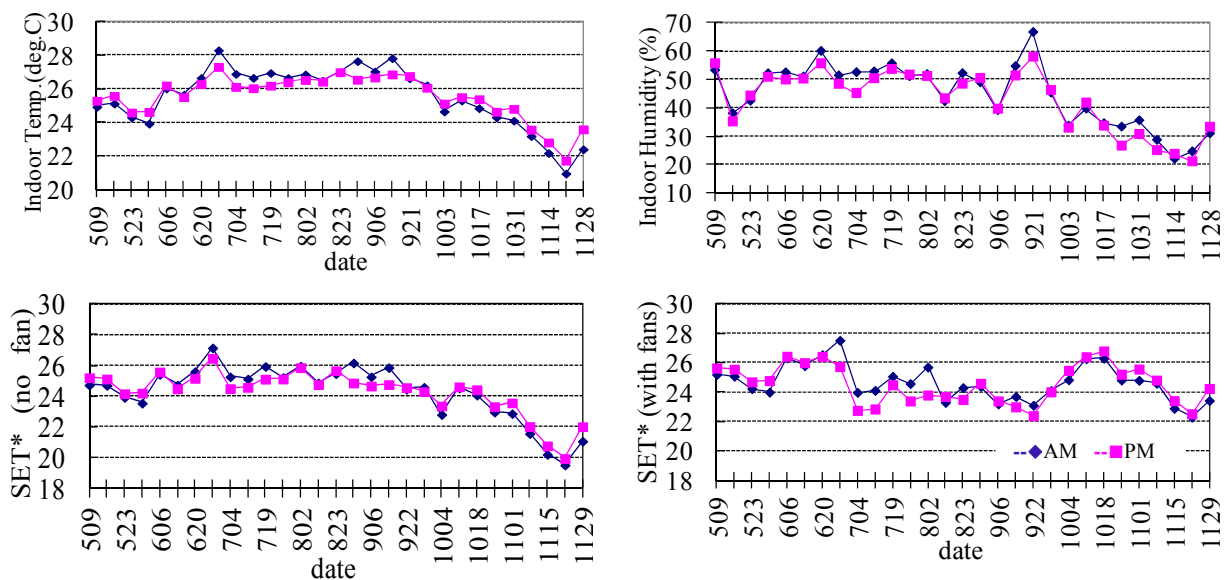

Figure 4. Weekly variations of indoor thermal environments.

3.3 Variations of thermal sensation and clothing insulation

Figure 5 shows weekly variations of outdoor and indoor thermal sensation and clothing insulation. Outdoor thermal sensation begins to increase from a neutral sensation at the end of May and reaches 7 at the end of August. Then the fluctuation decreases. It fell short of 4 at the end of September. Outdoor thermal comfort changes gradually from 'comfortable' to 'slightly uncomfortable' from May to late June. It is around 'slightly uncomfortable' from late June to the end of July. The fluctuation decreases in August and September. It is most 'comfortable' in October and increases again in November. The indoor thermal sensation is maintained at around 'neutral' until the beginning of November.

Clothing insulation begins to increase gradually at the beginning of June. It varies between 0.4 and 0.5 clo from July through September and begins to increase in late September. It increases steeply and reaches 0.6 clo in mid-October. Then it approaches 0.6 slowly.

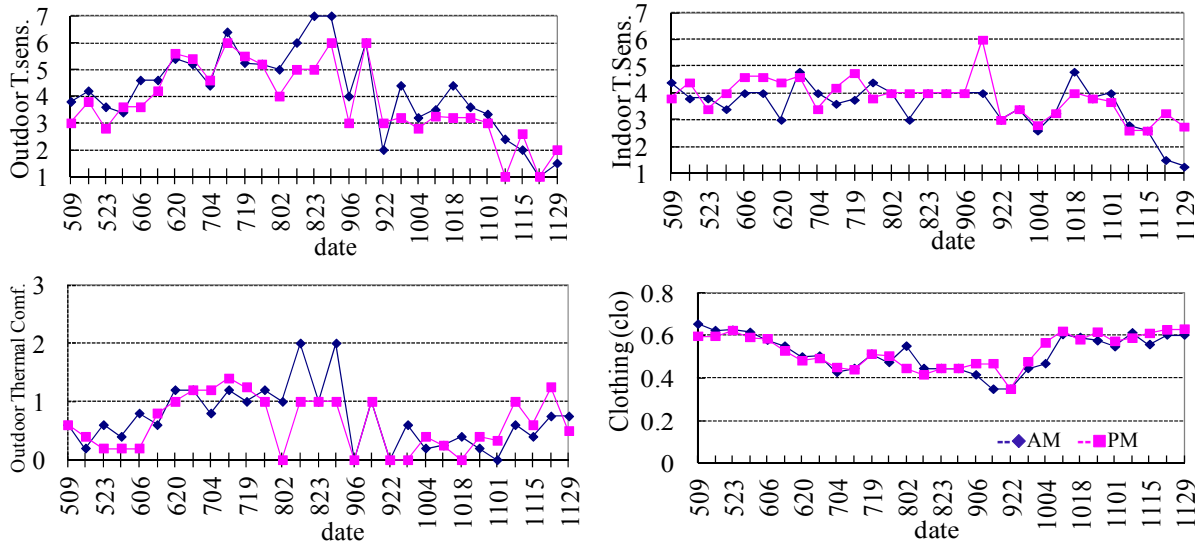

Figure 5. Weekly variations of thermal sensation and clothing insulation.

3.4 Variations of air-conditioner use ratio and window opening ratio

Figure 6 portrays weekly variations of the air-conditioner use and window opening ratios.

The ratio of air-conditioner use decreases in mid-May and increases again from June. It increases constantly and reaches a peak in mid-July. The high ratio is maintained until mid-August, when it begins to decrease, reaching zero in October. The rate of decrease is higher than the rate of increase. It increases smoothly but fluctuates more than when it is decreasing.

All windows of the buildings were observed. The opening ratio of all windows of laboratory rooms was used to define the window opening ratio.

The window opening ratio increases steeply between late May and mid-June. The peak value for the survey period comes in mid-June. After that peak, it begins to decrease steeply. The decreasing period accords to the rainy season. From mid-July, the end of the rainy season, it varies around 0.01 until early September. It becomes higher in September, although a trough is apparent in mid-September. It peaks again at mid-October and decreases slowly in November.

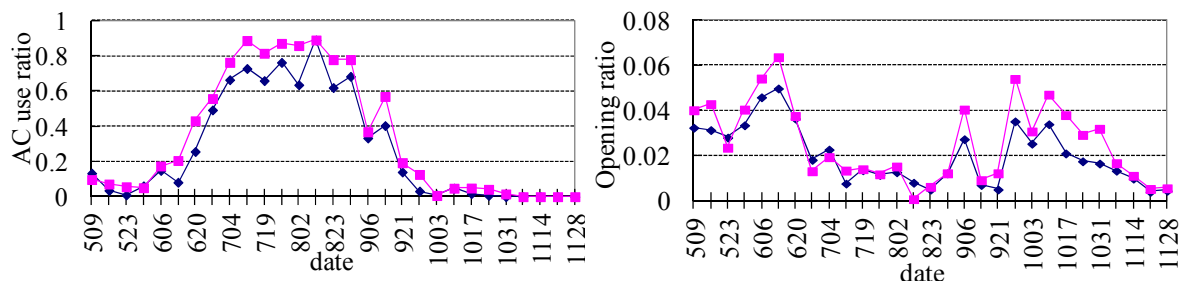

Figure 6. Weekly variations of thermal control use

4 Comparison among variations

Figure 7 portrays a comparison of variations of outdoor air temperature, outdoor thermal sensation, clothing insulation, air-conditioner use ratio, and window opening ratio. Values were standardized by the sample means and sample standard deviations, as described in 2.4.

Outdoor temperatures change from minus to plus at the end of May and change from plus to minus in mid-September. The plus duration is consistent with the total period of the early cooling season and cooling season.

Phase differences can be clarified by standardizing by each mean and each standard deviation. The variation of outdoor thermal sensation almost agrees with the variation of outdoor temperature. Air-conditioner use also changes similarly to outdoor temperature in the post-cooling season, but it is delayed about two weeks to the outdoor temperature in the pre-cooling season. Variations of air-conditioner use and window opening have just the reverse phases: they cross zero at almost identical times. Window opening changes reversely to the outdoor temperature. The zero agrees in the post-cooling season, but it is delayed about two weeks in the pre-cooling season. Clothing insulation lags the outdoor temperature by about one week in the pre-cooling season, but it lags about two weeks in the post-cooling season.

Agreement between air-conditioner use and window opening signifies that natural ventilation by window opening is used to control the indoor thermal environment as a substitute of air-conditioners. It supports the results of the former questionnaire surveys showing that occupants tend not to depend entirely on air-conditioners.

Certain time lags are apparent in adaptation to the change of outdoor temperatures in the changes of clothing and thermal control use. Occupants change their clothing in response to the outdoor temperature change, not in anticipation of it. The delay period is longer in the post-cooling season than in pre-cooling season. That fact might be associated to physiological or social aspects, or it might be associated with the difference of the effort to replace the wardrobe. Differences of clothing insulation are mainly caused by differences between short sleeve shirts and long sleeve shirts. Long sleeve shirts can be worn in all seasons, but students must prepare short sleeved shirts only for summer.

Air-conditioner use also lags the outdoor temperature. Air conditioners are used as the outdoor temperature increases, but with a time lag of about two weeks. However, air-conditioner use stops without a time lag when the temperature decreases. This is apparently related to the consciousness of air-conditioners as luxury devices. People feel hesitation to start air-conditioning in the pre-cooling season even if they feel warm. However, they feel able to stop it easily in the post-cooling season because they can stop it at the end of the day.

There is no adaptation time lag in thermal sensation to the outdoor temperature change in both pre-cooling and post-cooling seasons, different from the clothing and thermal control

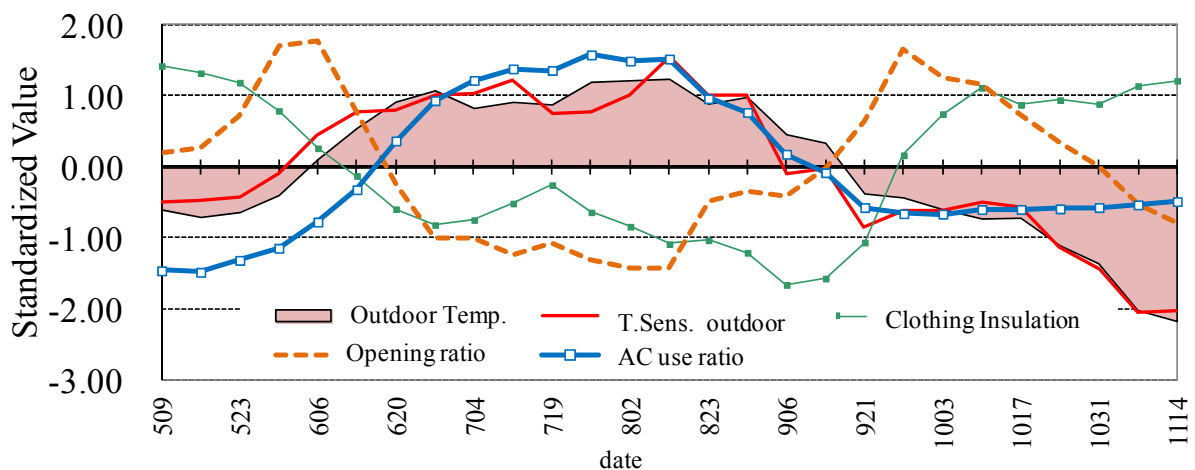

Figure 7. Comparison among weekly variations.

use. Occupants begin to feel warmer or cooler without lags according to the outdoor temperature change. Physiological abilities such as perspiration or blood flow control require a certain time to complete. However, Umemiya (2006) shows that the metabolic rate fall preceded the outdoor temperature increase in summer on the basis of identical thermal condition experiments throughout a year. Physiological items were not measured in this survey, but it is presumed that these abilities are acquired gradually in advance of the outdoor temperature change, so thermal sensation has no delay compared to the outdoor temperature change.

5 Conclusions

The indoor and outdoor thermal environment and air-conditioner use were measured in 28 rooms at 30 min intervals. In addition, the opening situations of 1056 windows were observed and indoor and outdoor thermal sensation and clothing ensembles were recorded twice a day from pre-cooling to post-cooling seasons at a university in Osaka. Results of the survey reveal the presence of a phase shift to the outdoor air temperature in thermal control use and clothing insulation, although no shift difference is found for thermal sensation. The phase shift differs between pre-cooling and post-cooling seasons. Variations of ratios of air-conditioner use and the area ratio of window opening are just in-phase in both pre-cooling and post-cooling seasons.

References

- Asawa. T et al., 2005. Analysis of the behavioural characteristics of both window opening and air conditioning use at detached houses: Relationship between outdoor microclimate and residents' living open to outdoor Part 2. *Journal of Environmental Engineering (Transactions of Architectural Institute of Japan)*, 593, pp87-94.
- ISO9920. 1995. *Ergonomics of thermal environment – Estimation of thermal insulation and evaporative resistance of a clothing ensemble*.
- Miyata,N et al., 2012. Discussion on the factors which affect the how to choose the methods of cooling themselves from the results of the questionnaire surveys in the four regions in western part of Japan. *Japanese Journal of biometeorology*, 49(1), pp 23-30.
- Rin.X et al., 2005. Survey of life style in summer for apartment house occupants in Osaka City. *Summaries of Technical Papers of Annual Meeting of Architectural Institute of Japan in 2005*, D(1), pp 859-860.
- Sakane.T et al., 2012. Changing sleep condition and energy saving action under power saving during the summer – Survey of Osaka. *Transactions of Annual meeting of Kinki Chapter of the Society of Heating, Air-Conditioning and Sanitary Engineers in Japan*, 41, pp 263-266.
- Umemiya.N., 2006. Seasonal variations of physiological characteristics and thermal sensation under the same thermal condition. *Journal of Physiological Anthropology and Applied Human Science*, 25(1), pp.29-39.
- Umemiya.N et al., 2006. Survey of control usage for apartments in Japan in summer and autumn: air conditioner and window opening. *Proceedings of the Windsor Conference for Comfort and Energy Use in Buildings*, Windsor, 6F, pp1-10.

Improvement of comfort conditions using confluent jets ventilation located near the floor level in an experimental chamber

Eusébio Z. E. Conceição ⁽¹⁾, M^a. Manuela J. R. Lúcio ⁽¹⁾ and Hazim B. Awbi ⁽²⁾

⁽¹⁾Faculty of Science and Technology - University of Algarve, Campus de Gambelas, 8005-139 Faro, Portugal

⁽²⁾School of Construction Management & Engineering, University of Reading, Reading, RG6, 6AW, United Kingdom

Abstract

In this work is analyzed the improvement of comfort conditions using confluent jets ventilation located near the floor level in front to the occupants in an experimental chamber. In this study are evaluated the thermal comfort, the local thermal discomfort and the air quality levels. The thermal comfort level is evaluated using the multi-nodal human thermal comfort numerical model, while the local thermal discomfort and the air quality levels are evaluated by the computational fluid dynamics numerical model. In the numerical simulation, made without and with occupation, are used one virtual chamber, two virtual thermal manikins, one virtual desk, two virtual seats and one virtual duct. The inlet confluent jets ventilation, built in a duct with a length of 1.3 m and a diameter of 0.125 m, has 49 holes with 5 mm diameter separated 25 mm among them. The outlet, with 0.25 m diameter, is placed near the ceiling level in the right side wall.

Keywords

Experimental chamber, Confluent jets ventilation, Computational fluid dynamics numerical model, Multi-nodal human thermal comfort numerical model, Thermal comfort, Local thermal discomfort, Air quality.

Introduction

In this work is evaluated the thermal comfort level, the local thermal discomfort level and the air quality level, that two seated occupants are subjected in an experimental chamber, using confluent jets ventilation located near the floor level. In the study, conducted in summer moderate conditions and inside an experimental chamber, is used a numerical methodology.

In the numerical methodology is used a coupling multi-nodal human thermal response (HTC) numerical model with a computational fluid dynamics (CFD) numerical model. In the turbulence model is applied the RNG turbulence model.

The coupling technique was applied in some works. Some examples can be found, as example, in Gau et al. (2006), Zhu et al. (2007) and Omni et al. (2007). Gau et al.

(2006) coupling the computational fluid dynamics and human body thermoregulation models, Zhu et al. (2007) coupling the simulation of convection, radiation, moisture transport and human thermal physiological model and Omni *et al.* (2007) coupling the simulation of convection, radiation and thermoregulation.

In the evaluation of the thermal comfort level in uniform environments is used the Predicted Mean Vote (PMV) and the Predicted Percentage of Dissatisfied people (PPD) indexes. These indexes were developed in Fanger (1970) and presented in ISO 7730 (2005) and ANSI/ASHRAE 55 (2004). These indexes are calculated by the air temperature, air velocity, air relative humidity, Mean Radiant Temperature, clothing level and activity level.

To evaluate the thermal comfort level, promoted by non-uniform environments, is used a multi-nodal human thermal comfort numerical model. This numerical model was applied, as example, in Conceição et al. (2006), Conceição et al. (2010a) and Conceição et al. (2010b).

The local thermal discomfort condition, evaluated by the Draught Risk (DR) index, was developed in Fanger et al. (1988). The Draught Risk depends on the air temperature, velocity and turbulence intensity. The Draught Risk was applied in several works, as example, in Fanger and Christensen (1986) and Melikov et al. (1990).

To evaluate the indoor air quality is used the carbon dioxide concentration released by the occupants and are used the recommendations presented in both ANSI/ASHRAE Standard 62.1 (2004) and the Portuguese normalization presented in D.-L. n° 79/2006 of April 4th. In both standards the limit carbon dioxide concentration is 1800 mg/m³.

In the confluent jets ventilation some studies were made in the last years. Some examples are presented in Karimipناه et al. (2005), Karimipناه et al. (2007) and Cho et al. (2008). In Karimipناه et al. (2005) was applied the confluent jets ventilation system in classrooms, in Karimipناه et al. (2007) were evaluated the air quality and comfort levels in classrooms, for different floor-level air supply systems, and in Cho et al. (2008) were compared the wall confluent jets ventilation and displacement ventilation.

Numerical model

In the numerical methodology is used the coupling multi-nodal human thermal comfort integral numerical model with the computational fluid dynamics numerical model, in non-uniform environment. The first numerical model evaluates the human body temperature, the clothing temperature, the water vapor fields, the thermal comfort level, while the second model evaluates the airflow around the occupants, the draught risk (based in empirical models) and the air quality level.

The computational fluid dynamics numerical model evaluates the environmental thermal variables around the occupants and these variables are used as input data in the multi-nodal human thermal comfort numerical model. The multi-nodal human thermal comfort numerical model evaluated the occupant and clothing thermal variables and these variables are used as input data in the computational fluid dynamics numerical model. In the numerical simulation these two numerical models were applied and used an iterative method.

The multi-nodal human thermal comfort numerical model was applied previously, as example, in Conceição et al. (2006), Conceição et al. (2010a) and Conceição et al.

(2010b). The multi-nodal human thermal comfort numerical model evaluates the body temperature, the clothing temperature, the skin water vapor, the clothing water vapor and the thermal comfort level. The multi-nodal human thermal comfort numerical model, based in mass and energy integral equations, works in transient conditions and simulates simultaneously a group of persons. The body is divided in 24 cylindrical and 1 spherical elements. Each element is divided in core, muscle, fat and skin layers and could be protected from external clothing layers.

The computational fluid dynamics numerical model (based in Patankar, 1980) was applied previously, as example, in Conceição et al. (2008) and Conceição et al. (2010b). The computational fluid dynamics numerical model evaluates the air temperature, air velocity and carbon dioxide concentration around the occupant. This numerical model is based in Navier-Stokes differential equations in Cartesian coordinates and works in steady-state conditions and in non-isothermal conditions. In the turbulence simulation the RNG models are applied.

The multi-nodal human thermal comfort numerical model and the computational fluid dynamics numerical model were previously validated.

More details about the multi-nodal human thermal comfort numerical model validation can be seen in Conceição et al. (2006), while more details about the computational fluid dynamics numerical model can be seen for isothermal conditions (Conceição et al., 2008), and non-isothermal conditions (Conceição et al., 2010b).

Numerical methodology

In the numerical methodology are used one virtual chamber, two virtual thermal manikins, one virtual desk, two virtual seats and one virtual duct.

In the numerical methodology, with and without occupation, the air velocity, air temperature and carbon dioxide concentration inside the chamber and around the occupants are calculated using the computational fluid dynamics numerical model, while the human body tissue temperature, the clothing temperature, the Mean Radiant Temperature and the thermal comfort level are calculated using the multi-nodal human thermal comfort numerical model.

In figures 1 and 2 are presented the geometry and the grid plans, without and with occupation. In the figure 1, the geometry is presented in figure a), the vertical and horizontal analyzed plans are presented in figure b), the confluent jets duct with grid is presented in figure c) and the confluent jets duct without grid is presented in figure d).

The calculated values are performed in a $48 \times 56 \times 48$ main grids: 5.45 cm spaced in X direction, 5.2 cm spaced in Y direction and 5.45 cm spaced in Z direction. The grids are refined near the walls and in front to the inlet and outlet.

In the numerical simulation the circular duct is approximated by a square duct. In the refined grid in the inlet duct each main grid is divided in 10 parts.

The inlet of the confluent jets ventilation, built in a duct with a length of 1.3 m and a diameter of 0.125 m, has 49 holes separated 25 mm among them with 5 mm diameter (see figures 1c and 1d). The outlet, with 0.25 m diameter, is placed near the ceiling level in the right side wall (see figure 1a).

In the philosophy considered in this confluent jets ventilation system presented in this work, the horizontal duct is placed above the floor level and in contact with a vertical

wall. The inlet air, placed along the confluent jets ventilation duct, is parallel to the floor surface. The inlet airflow, with high inertia, is developed along the floor surface in the occupied area.

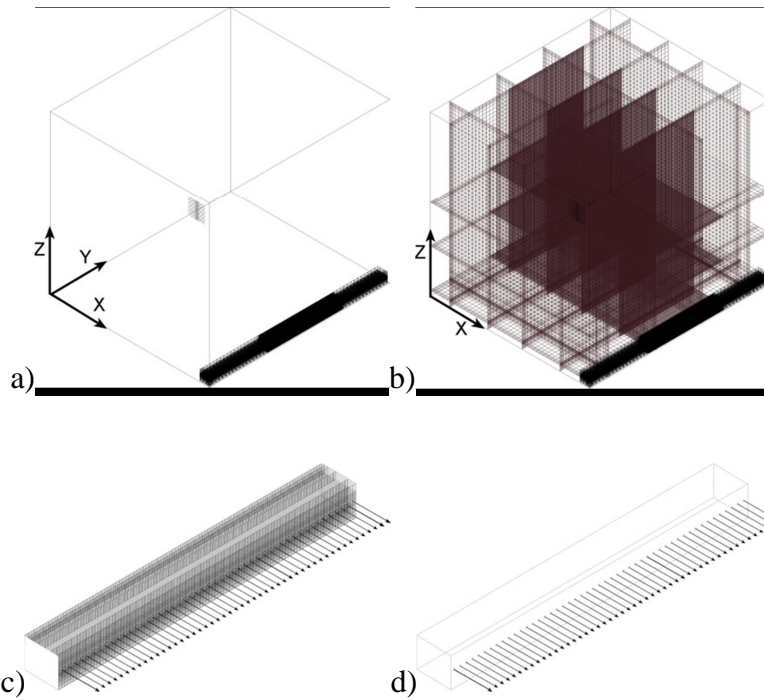

Figures 1 – Geometry of the confluent jets ventilation a), grid plans b),confluent jets duct with grid c) and confluent jets duct without grid d), without occupation.

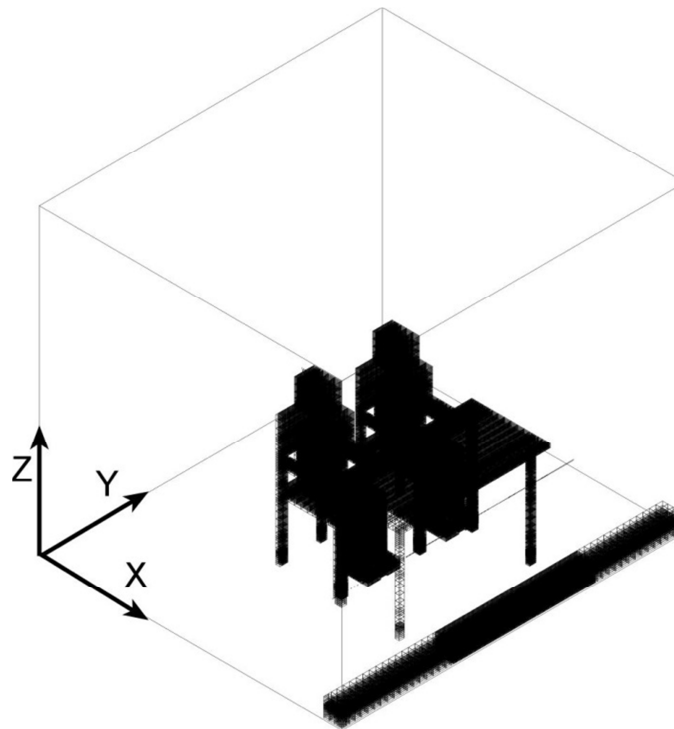

Figures 2 – Geometry of the confluent jets ventilation with occupation.

The virtual occupants had 1.70 m of height, 70 Kg of weight, 1.2 Met of activity level and 0.5 Clo of clothing level. In this numerical simulation the air temperature, air

velocity and Mean Radiant Temperature around the occupants are numerically calculated, while the considered mean air relative humidity is 50 %.

The inlet air velocity is 9.42 m/s, the inlet air temperature is 25 °C, the inlet air turbulence intensity is 11.25 % and the surrounding surface temperature is 25 °C.

Results and discussion

In this section is presented the study of the airflow inside the experimental chamber without and with occupation. The first simulation, without occupation, is made in steady-state regimen and in isothermal conditions, while the second simulation, with occupation, is made in steady-state regimen and in non-isothermal conditions.

In the first one, without occupation, after the validation tests, is evaluated the air velocity topology inside the chamber.

In the second one, with occupation, is evaluated the airflow around the occupants, the thermal comfort, the local thermal discomfort and the indoor air quality. In this last section are evaluated in detail:

- in the first part are presented the air velocity, air temperature and Mean Radiant Temperature, around the occupant, and the thermal comfort level;
- in the second part are showed the air turbulence intensity and the Draught Risk;
- in the third part is presented the carbon dioxide concentration.

Airflow inside the chamber without occupation

In this section are presented numerical results about the air velocity topology, without occupation. The numerical simulations are used to show in detail the airflow topology inside the experimental chamber.

In figure 3 is showed the air velocity fields in three XY horizontal plans located above the floor level. In figure 4 is presented the air velocity in four XZ vertical plans perpendicular to the confluent jets ventilation duct. Finally, in figure 5 is presented the air velocity in four YZ vertical plans parallel to the confluent jets ventilation duct. The results presented in this section are obtained through the computational fluid dynamics numerical model.

In accordance with the obtained results, when the inlet airflow arrives in the wall placed in front to the inlet, is promoted an airflow deflection upwards, namely to the ceiling area. This deflection is responsible for a rotational airflow inside an experimental chamber.

In this numerical simulation the highest air velocity value is showed in the floor level near the inlet area. In the occupied area the air velocity is relatively uniform and the air velocity value is around 0.2 m/s.

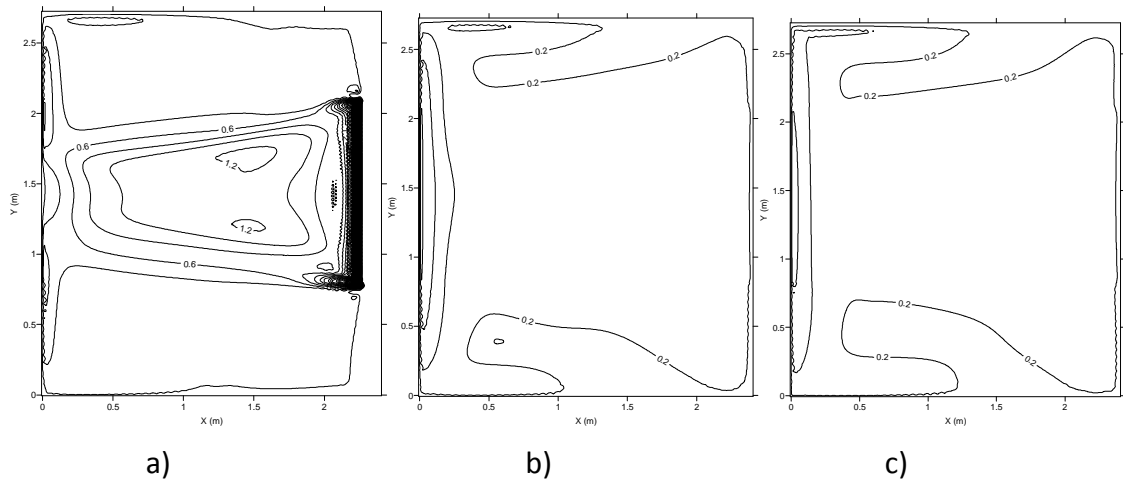

Figure 3. Air velocity fields in the XY horizontal plans located at $Z=0.07$ m a), $Z=0.63$ m b) and $Z=1.2$ m c) above the floor level.

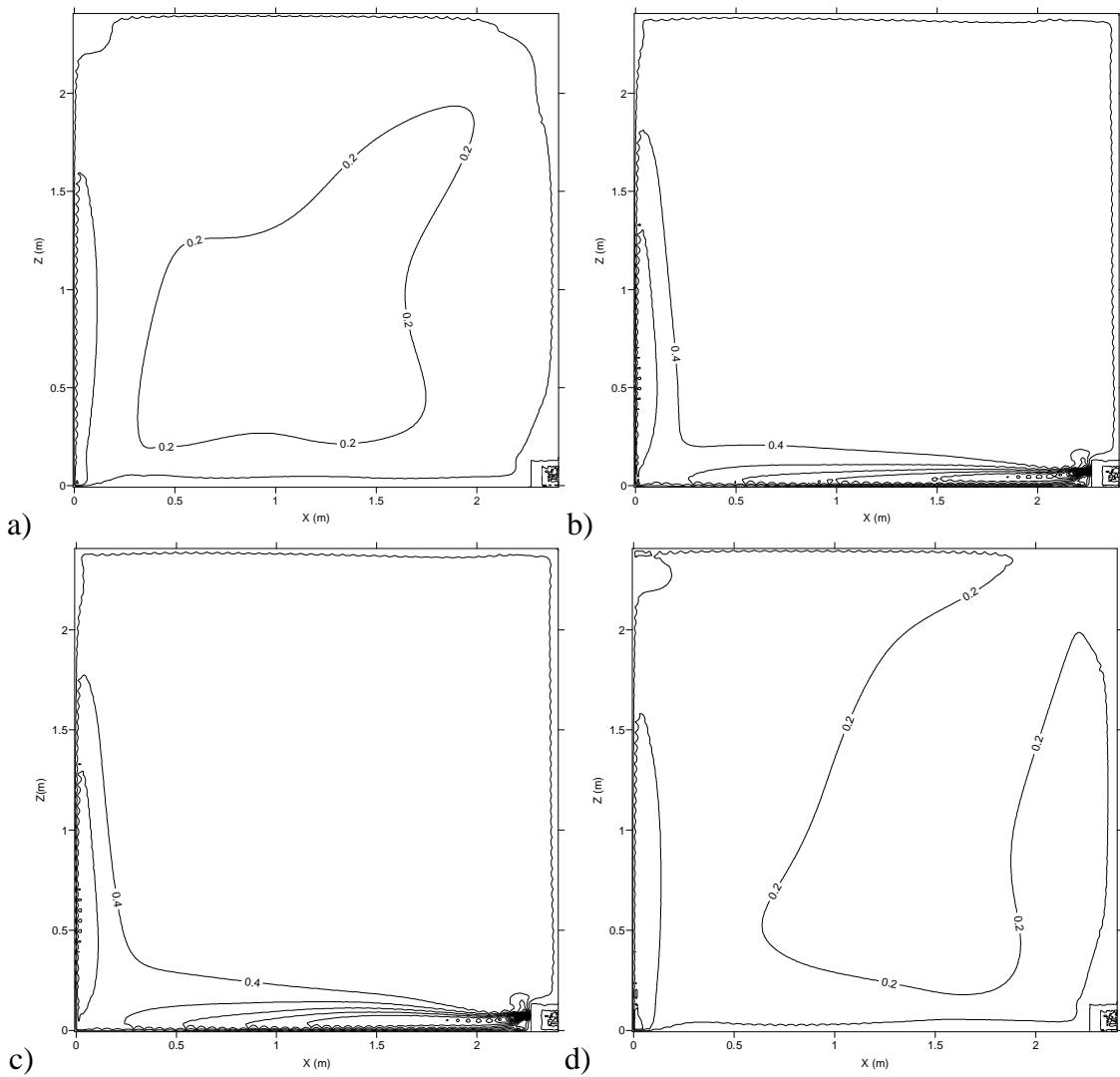

Figure 4 Air velocity fields in the XZ vertical plans located at $Y=0.3$ m a), $Y=1.0$ m b), $Y=1.7$ m c) and $Y=2.4$ m d).

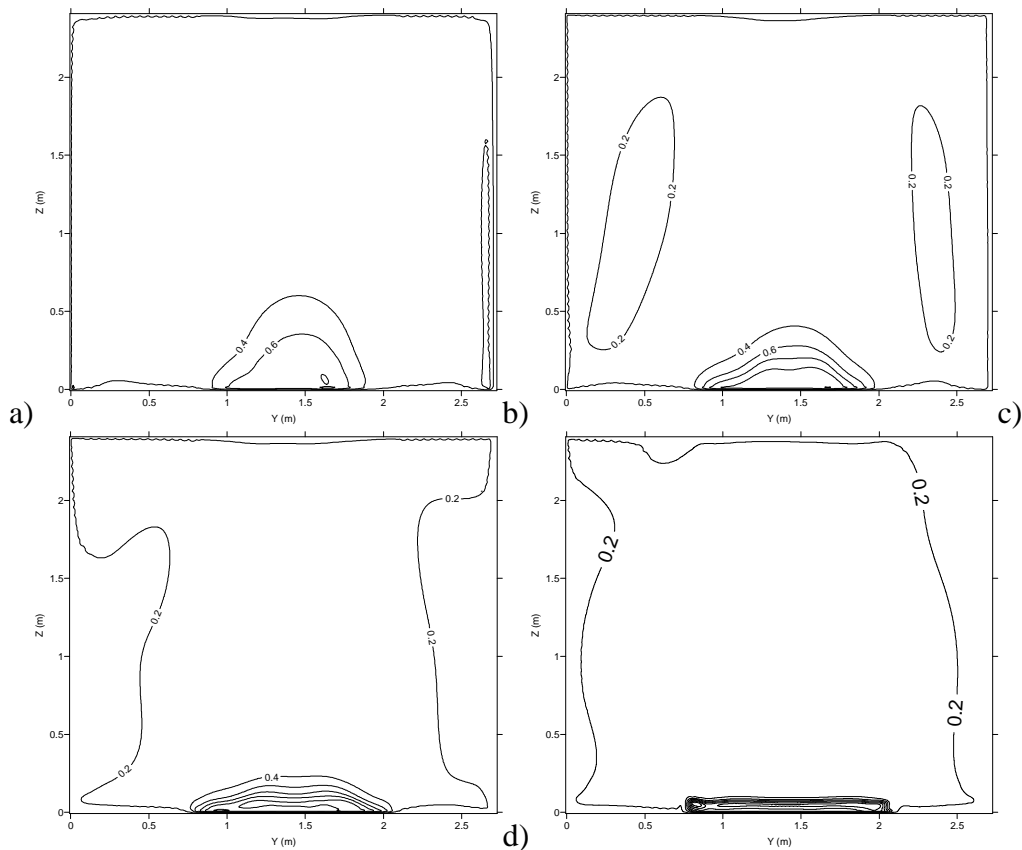

Figure 5 Air velocity fields in the YZ vertical plans located at X=0.3 m a), X=0.85 m b), X=1.4 m c) and X=1.95 m d).

Comfort inside the chamber with occupation

In this section are presented numerical results about airflow around the occupants, the thermal comfort, the local thermal discomfort and the indoor air quality. In the airflow around the occupants are presented the air velocity and air temperature around the 25 human body sections, in the thermal comfort are presented the Mean Radiant Temperature and the PMV and the PPD, in the local thermal discomfort are presented the air turbulence intensity and the Draught Risk around the 25 human body sections, while the indoor air quality are presented the carbon dioxide concentration in the breathing area.

In accordance with the obtained results part of the inlet airflow arrives near the occupants' lower members and is subjected to a deflection upwards to the occupant upper sections and other part of the inlet airflow arrives in the wall placed in front to the inlet and promotes an airflow deflection upwards to the upper area. The first part of the airflow promotes an ascendant airflow around the occupant, while the second part promotes a rotational airflow inside an experimental chamber.

As the human body surface temperature is higher than the chamber surrounding surface and the inlet air temperature, the ascendant airflow convection around the occupants is heated. Thus, the higher air temperature level is verified around the occupants.

In figure 6 are presented the air velocity calculated around the 25 human body sections of the two occupants. In figure 7 the same results are presented to the air temperature. Both results, namely the air velocity and the air temperature, are numerically calculated through the computational fluid dynamics numerical model.

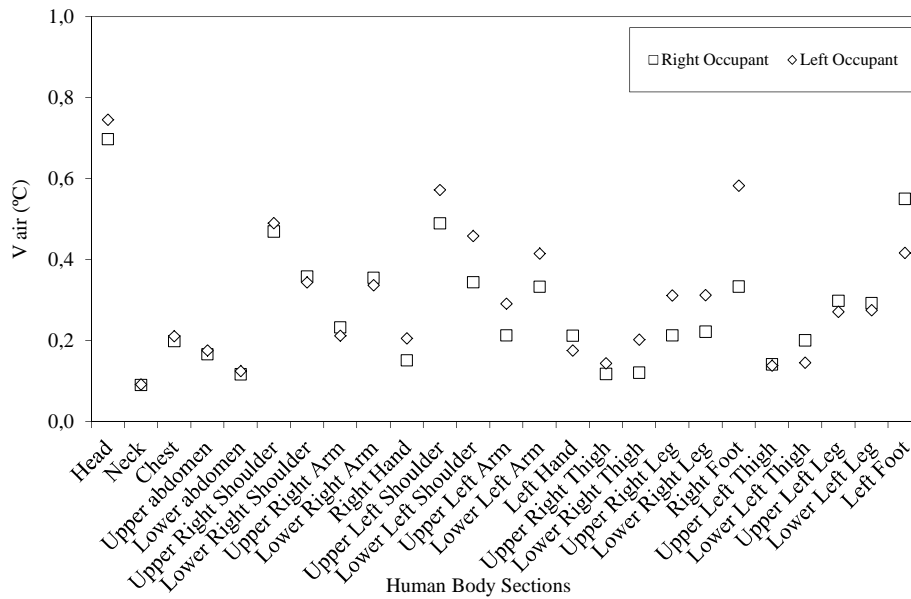

Figure 6. Air velocity, V_{air} , calculated numerically, around 25 human body sections of the two occupants.

The air velocity around the occupants is lower than the 0.8 m/s and the two occupants present similar air velocity levels. The air velocity is higher in the head, shoulders and feet. In the upper members the air velocity value slightly decreases and in the lower members the air velocity slightly increases.

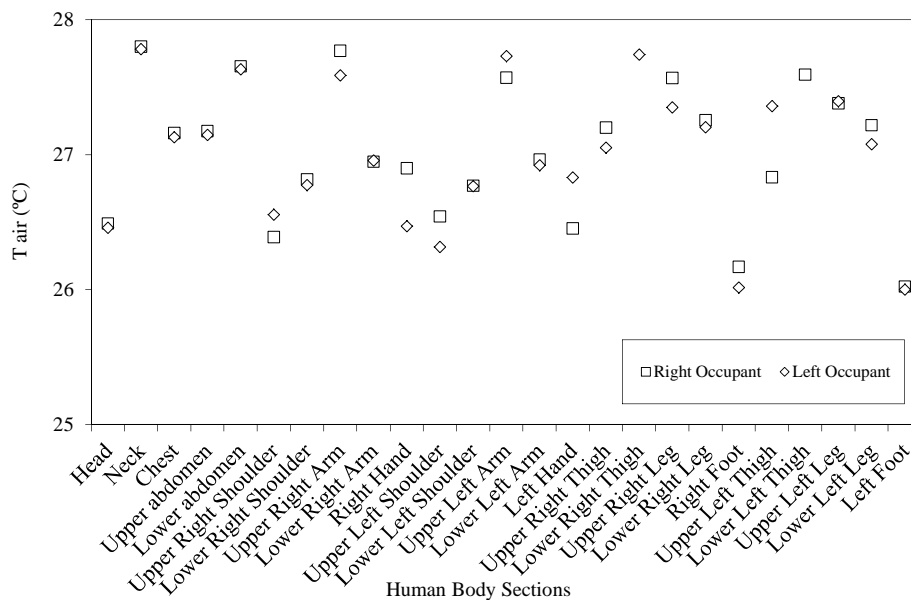

Figure 7. Air temperature, T_{air} , numerically calculated, around 25 human body sections of the two occupants.

The air temperature changes between the 26 and 28 °C and is lowest in the feet area. The two occupants present similar air temperatures levels.

The Mean Radiant Temperature (MRT), that the occupants seated in the right and left side are subjected, is presented in figure 8. The Mean Radiant Temperature is calculated numerically through the multi-nodal human thermal comfort numerical model.

The Mean Radiant Temperature changes between 25.5 and 30 °C. The Mean Radiant Temperature is highest in human body section influenced by other human body sections, subjected to radiation heat exchanges with these human body sections, and the Mean Radiant Temperature is lowest in human body sections influenced by surrounding chamber surfaces, subjected to radiation heat exchanges with these surfaces.

Figure 9 shows the skin surface temperature in 25 human body sections of the occupants seated in the right and left side. These results are calculated numerically through the multi-nodal human thermal comfort numerical model.

The skin temperature changes between the 32 and 34 and the two occupants present similar skin temperature. The skin temperature is higher in human body section protected by the clothing than the in human body section not protected by the clothing.

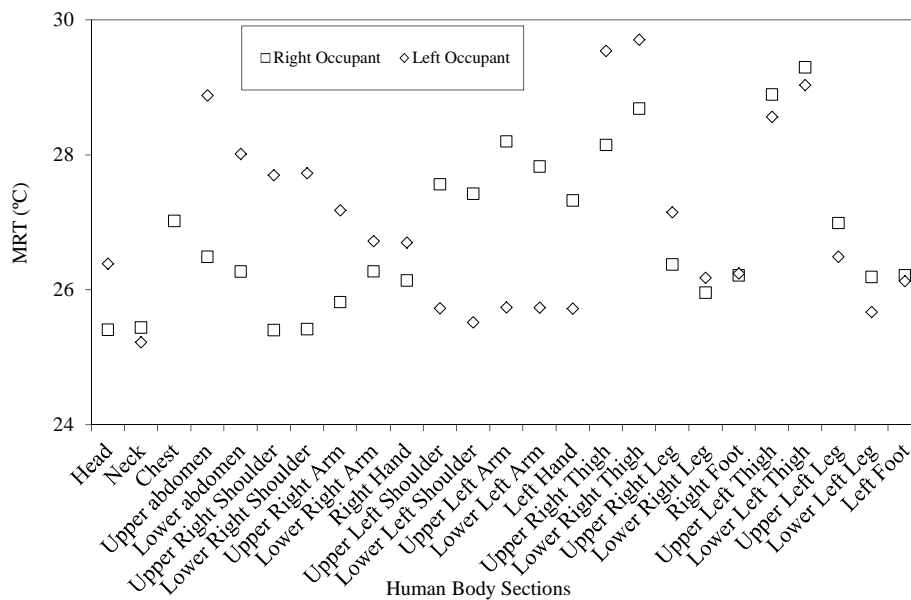

Figure 8. Mean Radiant Temperature, MRT, numerically calculated, in 25 human body sections of the two occupants.

In table 1 are presented the Predicted Mean Vote (PMV) and the Predicted Percentage of Dissatisfied people (PPD) indexes, obtained through the numerical model. Both results, namely the Mean Radiant Temperature and the Predicted Mean Vote and the Predicted Percentage of Dissatisfied people, are numerically calculated through the multi-nodal human thermal comfort numerical model.

In this study, in accordance with the ISO 7730 (2005), the category B with a maximum of 10 % of Predicted Percentage of Dissatisfied people, is used as acceptable thermal comfort conditions. In accordance with the obtained results, both occupants are thermally comfortable, in accord to the Category B, by positive PMV values, of ISO 7730 (2005).

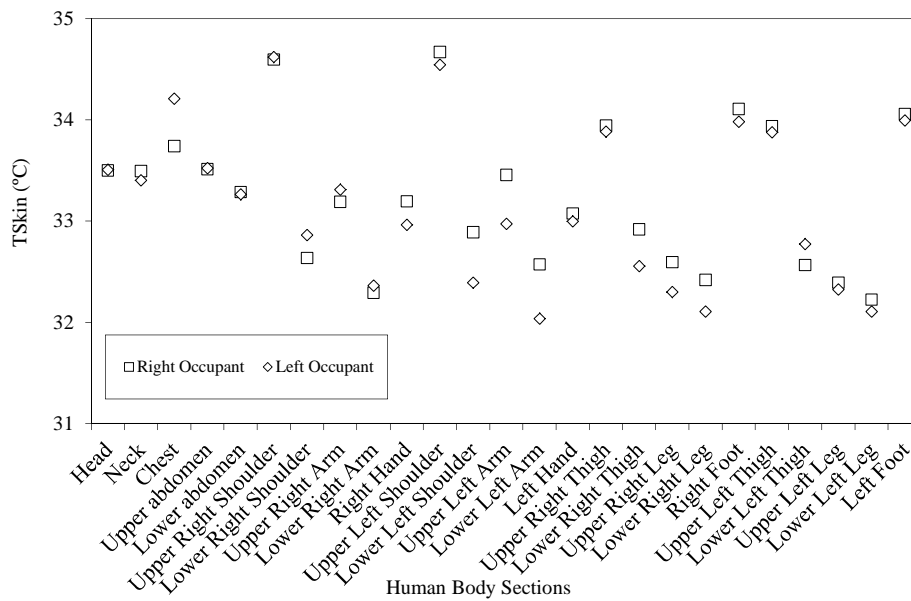

Figure 9. Skin surface temperature, T_{Skin}, numerically calculated, in 25 human body sections of the two occupants.

Table 1. PMV and PPD indexes numerically calculated.

	PMV	PPD (%)
Right side seated occupant	0.34	7.45
Left side seated occupant	0.48	9.94

In the local thermal discomfort evaluation is used the air turbulence intensity and the Draught Risk around the 25 human body sections. The air turbulence intensity values are presented for the right and left side seated occupants in figure 10, while the Draught Risk values are presented for the right and left side seated occupants, in figure 11. Both results, namely the air turbulence intensity and the Draught Risk, are numerically calculated through the computational fluid dynamics numerical model.

The air turbulence intensity around the occupants is lower than 7 % and the two occupants present similar air turbulence intensity levels. In general, the air turbulence intensity is lowest in the trunk and is higher in the head, upper members and feet. The air turbulence intensity around the two occupants decreases in the upper members and increase in the lower members.

The Draught Risk around the occupants are lower than the 30 % and and the two occupants present similar Draught Risk levels. In accordance with the ISO 7730 (2005), the category C with a maximum of 30 % of percentage of dissatisfied people is used as acceptable Draught Risk conditions. Thus, in this work the Draught Risk levels is in accordance with the category C of the ISO 7730 (2005).

The Draught Risk is highest in the head, shoulders and feet. The feet are influenced by the direct confluent jet ventilation and the head and the shoulders are influenced by the airflow recirculation. However, as the shoulders and the feet are protected by the clothing the Draught Risk is not important.

In the upper members the Draught Risk decrease and in the lower members the Draught Risk increase.

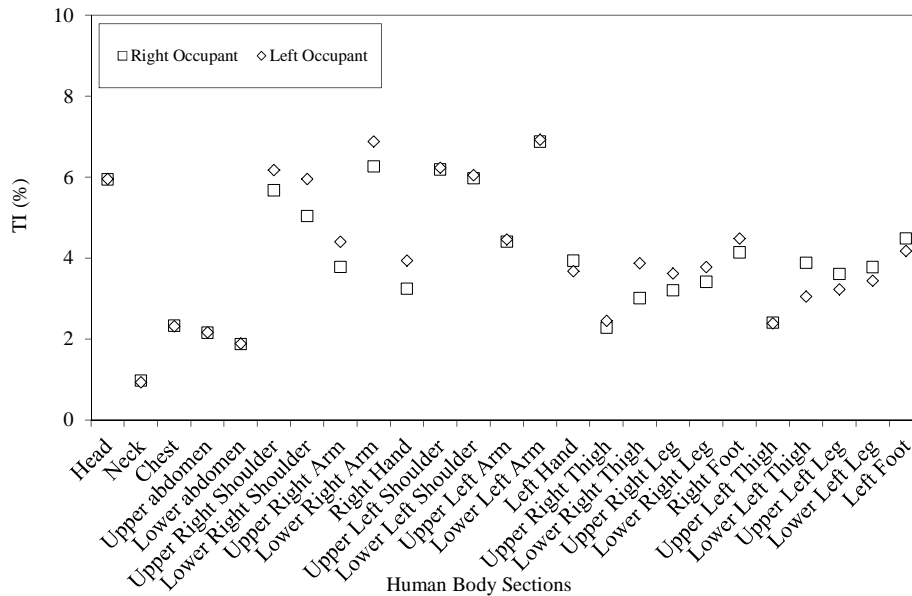

Figure 10. Air turbulence intensity, TI, numerically calculated, around 25 human body sections of the two occupants.

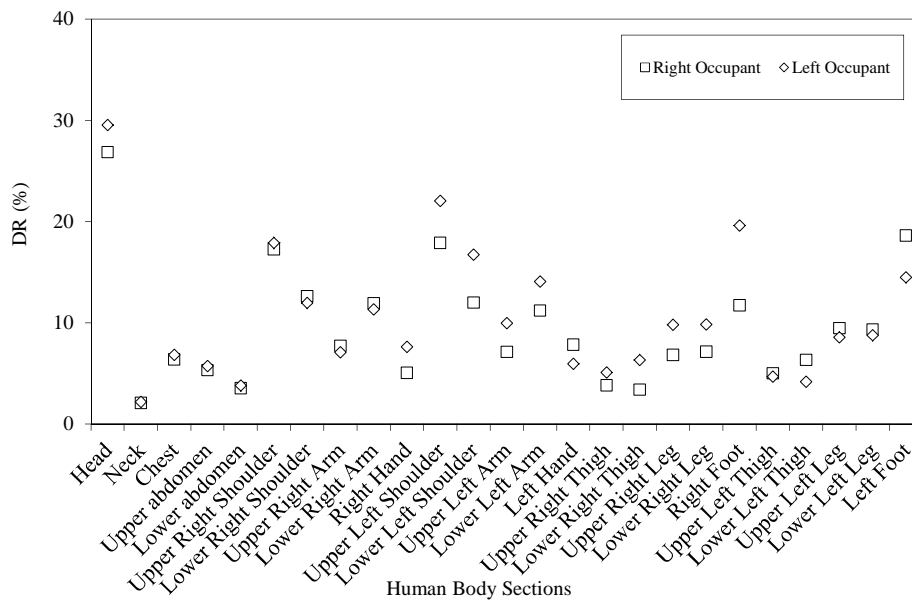

Figure 11. Draught Risk, DR, numerically calculated, around 25 human body sections of the two occupants.

In this study the carbon dioxide concentration released by the occupant is used to evaluate the internal air quality. In general, the carbon dioxide concentration inside the space is highest in the breathing area, of the two occupants, and the carbon concentration inside the space presents the same concentration that the inlet.

In Table 2 is presented the carbon dioxide concentration obtained in front to the nose area, for both occupants.

In accord to the obtained results, the carbon dioxide concentration in the breathing area is acceptable (in accord to ANSI/ASHRAE Standard 62.1 (2004) and D.-L. n° 79/2006 of April 4th) for both occupants.

Table 2. Carbon dioxide concentration numerically calculated in the breathing area.

	Carbon dioxide concentration (mg/m ³)
Right side seated occupant	1311
Left side seated occupant	1337

Conclusions

In this work the thermal comfort, the local thermal discomfort and the air quality levels are evaluated in an experimental chamber using confluent jets ventilation located near the floor level in front to the occupants. In the numerical simulation, made without and with occupation, a coupling of a multi-nodal human thermal comfort numerical model and a computational fluid dynamics numerical model is used.

In accordance with the results obtained the inlet airflow, from the duct equipped with the confluent jet ventilation, arrives at the wall placed in front to the inlet promoting airflow deflection upwards. When occupants are placed in front the duct equipped with the confluent jet ventilation, the supply airflow arrives near the occupants' lower parts and is then deflected upwards. The airflow inside the chamber is characterized through a global recirculation and, when the space is occupied at front of the duct equipped with the confluent jet ventilation, the airflow promotes an upward airflow around the occupant.

The air velocity around the occupants is lower than 0.8 m/s, the air temperature changes between the 26 and 28 °C, the Mean Radiant Temperature changes between the 25.5 and 30 °C and the skin temperature changes between the 32 and 34 °C. In general, the two occupants are exposed to similar air velocity, air temperature, Mean Radiant Temperature and skin temperature levels.

The results obtained show that the air velocity is highest near the inlet area, however, in the occupation area the airflow is uniform and lower than 0.2 m/s. When the chamber is occupied in the central region of the room, the highest air velocity is achieved directly at the feet area and indirectly (due the global recirculation) at the head and shoulders.

The correct evaluation of environmental parameters and the personalized variables are very important in order to achieve thermal comfort. The application of the integral and differential coupling models in this work is used to evaluate more exactly the air velocity and temperature field. It is suggested to evaluate the thermal influence on the surrounding occupants using, as example, the application of the Mean Radiate Temperature method. The application of the clothing level in the numerical simulation is another important step in order to improve the numerical method used in the thermal comfort evaluation.

In this study, the results obtained demonstrate that both occupants are thermally comfortable, in accord to Category B of ISO 7730 (2005) with the positive PMV values.

The local thermal discomfort level is evaluated by the Draught Risk around the occupants. In the present study, as verified by the air velocity and air turbulence intensity, the Draught Risk level is higher at the head, upper members and feet. The two occupants are exposed to similar air turbulence intensity and Draught Risk levels. In accordance with the results obtained, the Draught Risk level is within category C of the ISO 7730 (2005).

The feet are influenced by the confluent jet ventilation directly and the head and the shoulders are more influenced by the airflow recirculation. However, as the shoulders and the feet are protected by the clothing the Draught Risk is not expected to be very significant.

Finally, the results also show that the carbon dioxide concentration in the breathing area is acceptable for both occupants.

The results obtained in this experimental chamber test can be extrapolated directly for offices and small meeting rooms and can also be extrapolated, with some adaptations, for classrooms, large meeting rooms or other spaces for seated people.

In the present situation the confluent jets ventilation is located near the floor, in front to the occupants' bodies. This ventilation system promotes an airflow recirculation inside the space and the interaction between the airflow and the occupants produce acceptable thermal comfort and the air quality levels with low Draught Risk level.

In the future more validation tests will be performed using other situations which will be analyzed, numerically and experimentally. The confluent jets ventilation located in the floor level, in the ceiling level and in the corner between two lateral walls will also be analyzed.

Confluent jets air supplies using horizontal ducts located in the ceiling area in front to the occupants to produce a downward airflow, will also be carried out. Such an air supply will require higher air velocity than the confluent jets ventilation located on the floor.

The confluent jets air supply using a vertical duct that is located in the corner between two lateral walls in order to produce jet flow over the walls will also be carried out. The interaction between the airflow pattern and the occupants and its influence on the thermal comfort, air quality and Draught Risk will be analyzed.

Acknowledgment

This research activity is being developed inside a project supported by ROLEAR S.A.

The authors also grateful to the ECOFUNDING project.

References

ANSI/ASHRAE Standard 55, 2010. Thermal Environmental Conditions for Human Occupancy. American Society of Heating, Refrigerating and Air-Conditioning Engineers, Inc, 2010.

ANSI/ASHRAE Standard 62.1. 2004. ASHRAE Standard – Ventilation for acceptable indoor air quality, American Society of Heating, Refrigerating and Air-Conditioning Engineers, Inc.

Cho, Y., Awbi, H.B. and Karimipناه, T. 2008. Theoretical and experimental investigation of wall confluent jets ventilation and comparison with wall displacement ventilation. *Building and Environment*; 43 pp. 1091-1100.

Conceição E. Z. E., Lúcio M^a M. J. R., Capela T. L. and Brito A. I. P. V. 2006. Evaluation of thermal comfort in slightly warm ventilated spaces in non-uniform environments. *International Journal of Heating, Ventilating, Air-Conditioning and Refrigerating Research, ASHRAE*, Vol. 12, N. 3, pp. 451-458.

Conceição E. Z. E., Lúcio M^a M. J. R., Rosa S. P., Custódio A. L. V., Andrade R. L. and Meira M^a J. P. A. 2010b. Evaluation of comfort level in desks equipped with two personalized ventilation systems in slightly warm environments, *Building and Environment*, Volume 45, Issue 3, March 2010, pp. 601-609.

Conceição E. Z. E., Rosa S. P., Custódio A. L. V., Andrade R. L., Meira M^a J. P. A. and Lúcio M^a M. J. R. 2010a. Study of Airflow Around Occupants Seated in Desks Equipped With Upper and Lower Air Terminal Devices for Slightly Warm Environments, *International Journal on Heating Air Conditioning and Refrigerating Research, ASHRAE*, Vol. 16, N. 4, July 2010, pp. 401-412.

Conceição, E. Z. E., Vicente, V. D. S. R. and Lúcio. M^a M. J. R. 2008. Airflow inside school buildings office compartments with moderate environment. *International Journal on Heating Air Conditioning and Refrigerating Research, ASHRAE*, Vol. 14, N. 2, March 2008, pp. 195-207.

Decreto-Lei nº 79. 2006. Regulamento dos sistemas energéticos de climatização em edifícios (RSECE), *Diário da República*, I Série- A, N. 67, April 4th.

Fanger P.O. 1970. Thermal comfort. Copenhagen: Danish Technical Press.

Fanger, P. O. and Christensen, N. K. 1986. Prediction of Draught in Ventilated Spaces, *Ergonomics*, V. 29, pp. 215-235.

Fanger, P., Melikov, A. Hazawa, H. and Ring, J. 1988. Air turbulence and sensation of draught, *Energy and Buildings*, Vol.12, pp. 21-39.

Gau, N., Niu J. and Zang, H.. 2006. Coupling CFD and Human Body Thermoregulation Model for the Assessment of Personalized Ventilation. *International Journal of Heating, Ventilating, Air-Conditioning and Refrigerating Research, ASHRAE*, Vol. 12, N. 3, pp. 497-518.

ISO 7730, 2005. Ergonomics of the thermal environments – analytical determination and interpretation of thermal comfort using calculation of the PMV and PPD indices and local thermal comfort criteria. International Standard. Switzerland.

Karimipannah, T., Awbi, H.B., Blomqvist, C., and Sandberg M. 2005. “Effectiveness of confluent jets ventilation system for classrooms”.

Karimipannah, T., Awbi, H.B., Sandberg, M. and Blomqvist, C. 2007. Investigation of air quality, comfort parameters and effectiveness for two floor-level air supply systems in classrooms. *Building and Environment*; 42, pp. 647-655.

Melikov, A. K., Langkilde, G. and Derbiszewski, B. 1990. Airflow Characteristics in the Occupied Zone of Rooms with Displacement Ventilation, *ASHRAE Transactions*, V. 96, Part. 1, pp. 555-563.

Omni, O and Tenabe, S. 2007. Coupled Simulation of Convection-Radiation-Thermoregulation for Predicting Human Thermal Sensation. *RoomVent'2007*, Tenth International Conference on Air Distribution in Rooms, Helsinki, Finland, 13-15 June 2007.

Patankar, S.V. 1980. Numerical heat transfer and fluid flow. Hemisphere publishing corporation.

Zhu, S., Kato, S., Ooka, R., Sakoi, T. and Tsuzuki, K. 2007. Coupled Simulation Method of Convection, Radiation, Moisture Transport and Sakoi Human Thermal Physiological Model to Simulate Heat Exchange from a Person Seated in a uniform environment. *RoomVent'2007*, Tenth International Conference on Air Distribution in Rooms, Helsinki, Finland, 13-15 June 2007.

Proceedings of 8th Windsor Conference: *Counting the Cost of Comfort in a changing world* Cumberland Lodge, Windsor, UK, 10-13 April 2014. London: Network for Comfort and Energy Use in Buildings, <http://nceub.org.uk>

Solving the Black Box: Inverse Approach for Ideal Building Dynamic Behaviour Using Multi-Objective Optimization with Energyplus

Nelly Adriana Martinez

University College London, Bartlett School of Graduate Studies, Faculty of the Built Environment, London, UK, n.martinez.12@ucl.ac.uk

Abstract

The need for zero carbon buildings is changing the trial-and-error process that Architectural design has traditionally employed towards a system that allows wider analysis capacity at the conceptual stage. By visualizing design as a “Black Box” where the composition variable B can be cleared from knowing the stimuli S and the desired response R; optimal solutions arise to the surface. The Dutch FACET project which initiated to find the ideal dynamic properties of a building shell to get the desired indoor climate at variable outdoor conditions implemented this inverse approach and served as inspiration for this work which will build on their findings but implementing a two-step methodology. (1) Fabric properties were optimized using EnergyPlus+jEPlus+EA aiming to reduce heating & cooling energy and minimize thermal and visual discomfort. (2) Best solutions were used to create an ideal dynamic building using the best performance at each timestep and interchanging material properties accordingly. The results presented indicate that adaptive behaviour stands as a promising way to harmonize energy consumption and discomfort levels conflictive nature.

Keywords: Multi-objective optimization, Dynamic building, EnergyPlus, jEPlus+EA

1. Introduction

The ever changing conditions that a building is subject to, make reaching optimal performance along the entire time a difficult task to achieve. Weather and user patterns greatly fluctuate along time in contrast to the steady parameters that are perceived as comfortable for the people inside them. They are the bases that determine energy consumption for, whenever these are not met, artificial systems enter to recreate a benevolent atmosphere. This contradictory paradigm along with the traditional way of conceiving buildings as static elements places their design out of context; not following the logic behind a dynamic environment.

The search for a built environment that reconciles energy efficiency, comfort and health has led to strategies that follow passive and nature design concepts, artificial systems efficiency or alternative energy sources. Although these paths have for sure signified a progress; current building stock performance shows that much is still left to do. Proposing buildings with the capacity to mutate offers the possibility to combine the best of these strategies and provide optimal performance under any circumstance.

Acting as the difference between the exterior and interior; adaptations of the building fabric have the greatest potential to transform conditions into acceptable ranges by changing its properties and by hence the way energy is balanced. Advances in

technology and material science have made this a possibility already achievable; a series of “smart windows” can vary opacity or infrared transmittance according to different conditions and Nanotechnology and Micro-engineering have found in the atomic level a way to manufacture materials that respond in ways that were not possible before.

Incorporation of adaptive behaviour is changing the Architectural method from solving a space to solving a process (Loonen 2010), where successful designs are determined by the analysis capacity at the conceptual stage when the world of possibilities is large. This work will explore the implications that adaptive behaviour in buildings carry to the design conception and emerging tools identified by previous research in the field (Wang et al. 2005), (Bakker et al. 2009), such as Multi-objective Optimization (MOO) and the Inverse Approach for their potential to balance the conflict between comfort and energy savings.

2. Building Adaptive Concepts

Multiple adjectives are commonly used in an attempt to describe a building’s non-static behaviour. Such buildings are commonly referred in literature as: active, dynamic, adaptive, kinetic, responsive, living, smart, interactive, high performance or advanced, to name some (Schnadelback 2010), (Loonen et al. 2013), (Velikov & Thün 2013). Since few years ago different initiatives have tried to cluster and define under one concept these buildings that accommodate to the ever changing external and internal conditions in a search for communication, energy efficiency, health and comfort.

Environmentally Responsive

The Energy Conservation in Buildings & Community Systems (ECBCS) programme, coordinated by the International Energy Agency (IEA) In 2004, unified the concept under Responsive Building Concepts (RBC) & Responsive Building Elements (RBE) which definition and design guidelines were published in Annex 44 (Aschehoug & Perino 2009), (Heiselberg 2012). In this case responsive referred to the ability for energy capture, energy transport and/or energy storage (Heiselberg 2009). Information from existing cases was collected in an aim to maximize their potential and a design approach which articulated responsive building elements, building services and renewable energy systems through an integrated design process where the different experts are involved from the conceptual stage was proposed. Its weakness is that they relied on the same method architecture had been conceived and focused only on commercial technologies.

Adaptive Architecture

This concept stills somewhat ambiguous but seems to have begun to form about a decade ago in an effort to describe these emerging examples. Its objectives are not only environmental but also societal and communicational. Even though many authors have discussed it; perhaps the best effort to give it a framework are those by (Lelieveld et al. 2007) who as part of her Ph.D. defined it as “Architecture from which specific components can be changed in response to external stimuli” and (Schnadelback 2010) who defined its drivers, what they react to, methods, elements and effects. Although his categorization has a humanistic approach where environmental goals belong to the social motivations together with lifestyle and fashion; it allows inclusion of internal and aesthetic adaptations regardless of whether or not they have a physical effect.

Climate Adaptive Building Shells (CABS)

Initiated in The Netherlands, hub for research in the field for several years, CABS started as a research project between the Organization for Applied Scientific Research (TNO), Energy Research Centre of the Netherlands (ECN) & University of Plymouth in 2008. It was defined and contextualized by (Loonen 2010) in his MSc Thesis as:

“A climate adaptive building shell has the ability to repeatedly and reversibly change its functions, features or behaviour over time in response to changing performance requirements and variable boundary conditions. By doing this, the building shell effectively seeks to improve overall building performance in terms of primary energy consumption while maintaining acceptable thermal and visual comfort conditions.”

It is until now the best one documented with a database of around 200 built, prototype and patented cases (Loonen n.d.). His categorization was found to be the most successful as it uses simulation tools logic, layering them according to the physical domain involved and presenting them as the result of a process. It will be the one on which sections 2.1 and 2.2 develop.

2.1. Adaptation Mechanisms

Adaptation in architecture has been found to be determined by either the material's inherent ability to change (micro-scale) or a mechanism assembled to produce the transformation (macro-scale). At the micro-scale, physical properties of materials vary according to how they convert a certain energy input (potential, electrical, thermal, mechanical, chemical, nuclear and kinetic). When this energy affects the material's molecular structure the result is a change of its properties, but when it is the energy state the one affected then the result is an exchange of energy. In one, the energy is absorbed and the material undergoes a transformation while in the other the material stays the same but the energy changes (Addington & Schodek 2005). At the macro-scale properties are changed through movable parts using the effect of forces for moving objects and involving the dimension of time (Crespo 2007). They operate according to ambient, scheduled or personal preferences and changes are triggered by a sensor that registers conditions and drives the data to be interpreted by a processor which subsequently sends a signal to the corresponding actuator for an action to be executed.

Whatever the adaptive mechanism is, it requires a time lag to change from one state to another which could happen from a matter of seconds to hours, days, seasons and so on. Moreover the mechanism driving the change not always performs the same on both directions, for example reactions activated through chemical means can return to the original state thermally or materials that obscure according to temperature perform differently when heating up than when cooling down; quality known as Hysteresis.

2.2. Physical Domains

In the realm of controlling external varying conditions to keep an ideal internal environment; skin has given the example to follow being object of multiple analogies in architecture (Vassela 1983), (Drake 2007). Human skin adapts to temperature and humidity, is waterproofed but permeable to moisture, feels draft and touch and repairs itself keeping organs healthy and comfortable (Wigginton & Harris 2002). Being the limit between outdoors and indoors, just as skin, the building envelope is exposed to a diversity of forces and therefore has the ability to regulate them as required. Loonen

distinguished four physical domains with their respective interdependencies on which CABS act in order to adjust internal conditions: Thermal, Optical, Air-flow and Electrical (See Figure 1) and suggested Sound and Moisture as possibilities not included for not existing yet an example (Loonen et al. 2013).

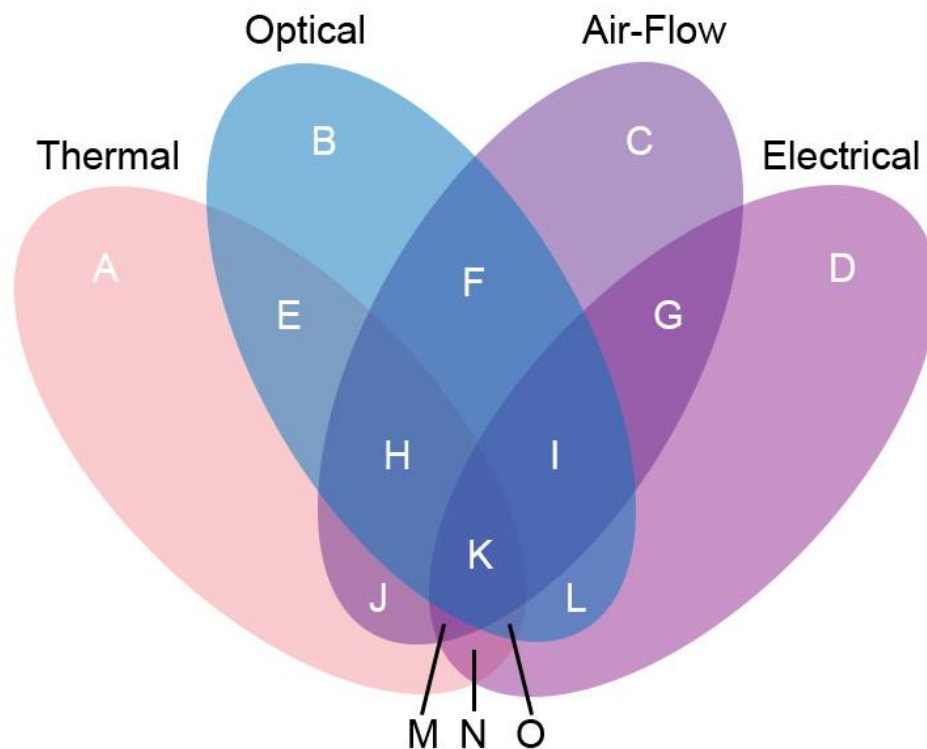

Figure 1. CABS Physical Domains

This categorization simplified the complexity embed in building adaptation but mixed an end-result with the means to achieve it. In terms of energy efficiency, Optical properties of materials can be adjusted to improve thermal comfort but adaptations that just end up in a change of visual perception are not relevant. The same case applies to the Electrical and Air-flow domains; adaptations that generate electricity are only relevant if it is actually used to improve building's performance and the Air-flow ones only if they act on indoor air quality and thermal comfort. More over the scope should allow space for all the required needs regardless of whether or not examples exist, although materials that absorb moisture (Hygroscopic) have been known for years and research shows they can moderate indoor humidity conditions (Simonson et al. 2004). Products like hydrogel are being investigated to absorb/release air water vapour to control indoor humidity (Johnson & Kulesza 2007). Researches like "Building Things that Talk II" by the Responsive Skins Initiative (Yazdani et al. 2011) shows how an acoustic stimuli could trigger an actuator which could easily be translated into buildings that can control the decibel levels admitted.

To overcome these limitations a new scheme is proposed identifying five domains that adaptations targeting to reduce energy consumption and maximize comfort pursue (See

Figure 2): Thermal, Visual, Moisture, Acoustic and Indoor Air Quality (IAQ), where each one is achievable through four different means or their interrelation: Electrical, Optical, Mechanical or by Reaction (Chemical, Radiant, Magnetic, Thermal, Fluid). Even though adaptation in buildings might have other targets such as communication or social connectivity those have not been explored in this work.

- T – Thermal
- M – Moisture
- A – Acoustic
- I – Indoor Air Quality
- V – Visual

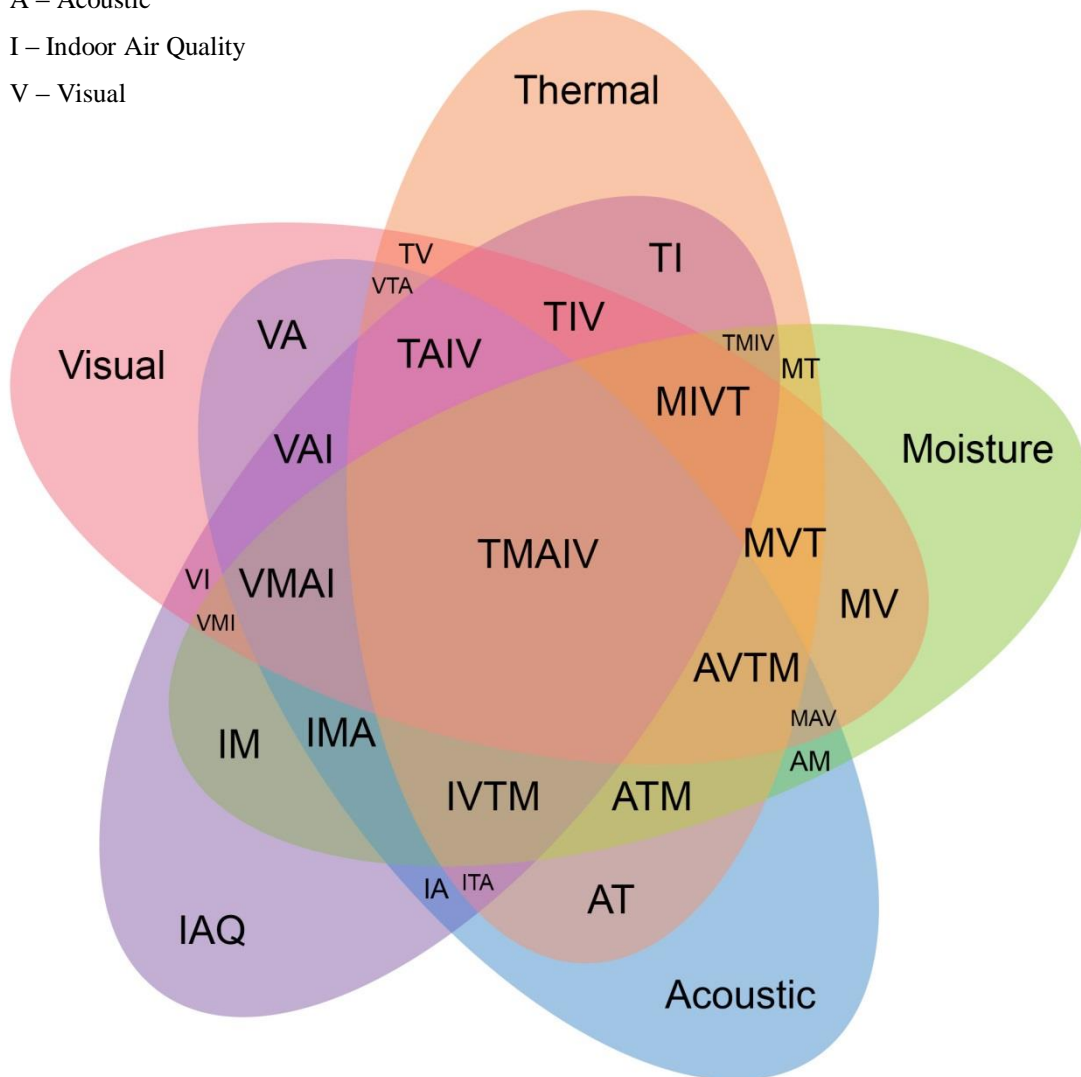

Figure 2. Adaptation Target Scheme

3. Solving the Black Box

A black box is an imaginary representation of a set of systems affected by a stimuli S and out of which reactions R emerge. The constitution and structure of the box are irrelevant and only the behaviour of the system matters. This is what one of the greatest second order cyberneticians referred to as “trivial machine”; one which couples a particular stimulus with a specific response (Foerster 2003). In his work he mentions that all machines we construct or buy are, hopefully, of this kind to perform the task they have been designed for.

Our search for buildings that do not require fossil fuels inevitably leads to the investigation of unusual devises (Glynn 2008); where cybernetics has several lessons for building designers as adaptive systems are intrinsically dynamic becoming the design of a process rather than an “artefact” (Moloney 2007).

The approximation to the black box depends on the problem one is looking to solve, for the simplest ones it is assumed that the intensity of the output R at a certain time is determined by the intensity of the input S at a prior time; from where three possible problems can be postulated (Bunge 1963):

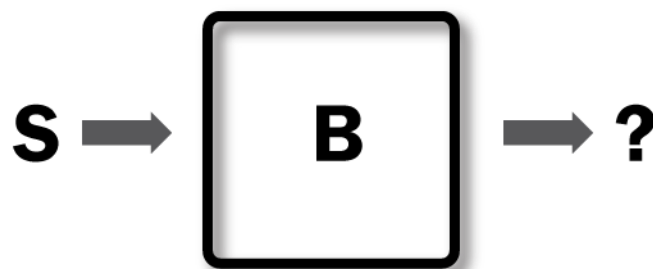

Figure 3. The Problem of Prediction

Given the kind of box and the stimulus S , find the response R .

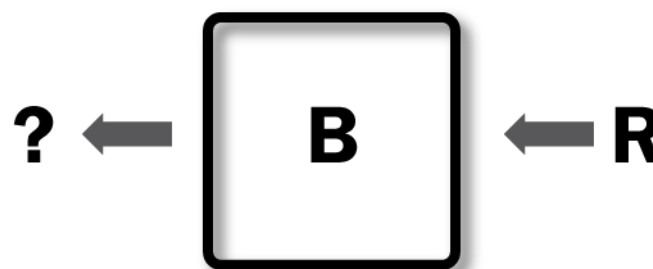

Figure 4. The Inverse Problem of Prediction

Given the kind of box and the response R , find the stimulus S responsible for the behaviour.



Figure 5. The problem of explanation

Given the behaviour R under a known stimuli S , find the kind of box that accounts for the behaviour.

In the case of buildings the problem might not be as “obscure” and could be better addressed as “Gray Box” due to the fact that they have enough internal constraints based on physical laws built into them (Reddy 1989). Architectural design has been treated as the kind of problem number 1 where once a design is proposed; its performance is calculated hoping to get the desired results. No wonder why we have failed in the design of a simple trivial machine and our buildings don’t behave the way we want.

Five years ago the Dutch FACET project was initiated with the objective to solve the question of: “What would be the ideal, dynamic properties of a building shell to get the desired indoor climate at variable outdoor climate conditions?” (de Boer n.d.); which has been the inspiration for the present work. This query specifically deals with the kind of problem number 3 and, as Bunge describes, is not well-determined and therefore does not have a unique solution.

3.1. Methodology

An ideal building would provide comfort with zero energy implications, dynamic adaptations of the fabric could absorb the ever changing external climate to keep internal conditions in the narrow comfort band with the lowest energy use. This work has focused on thermal and visual conditions as comfort indicators and cooling and heating loads as the energy ones. The desired thermal comfort will be based on ASHRAE 55-2004 humidity ratio and operative temperature parameters using a Clo level of 0.5 for summer and 1.0 for winter. While optimal visual comfort will be based on a maximum allowable discomfort glare index of 22 as recommended in (EnergyPlus 2013b) reference guide.

To find the parameters that a fabric should have in order to obtain the desired indicators a method called “System Parameter Identification” colloquially referred to as the “Inverse Approach” will be implemented. It is commonly applied to existing buildings as it is a technique where energy behaviour is identified from performance records while in actual operation (Reddy 1989). Input data typically includes static building information and dynamic (time dependent) weather and energy consumption reports (An et al. 2012). This time building information will be dynamic and energy consumption and discomfort static at zero (or to approximate zero) replacing thus metered reports and enabling the method to be used at a design phase.

The FACET project proposed the inverse approach as a feasible way to find ideal properties of adaptive shells (Boer et al. 2011), (Boer et al. 2012), (Bakker et al. 2009) but, while it was running, only got to evaluate comfort and energy independently and analysed adaptivity simply in terms of what smart façade glazing and adjustable shading options could offer disregarding opaque surfaces potential. It also proposed the implementation of multi-objective optimization (MOO) as a future step to visualize the performance benefits of CABS going beyond what static designs could offer towards a utopia point where comfort and energy don't conflict (Boer et al. 2011) (See Figure 6).

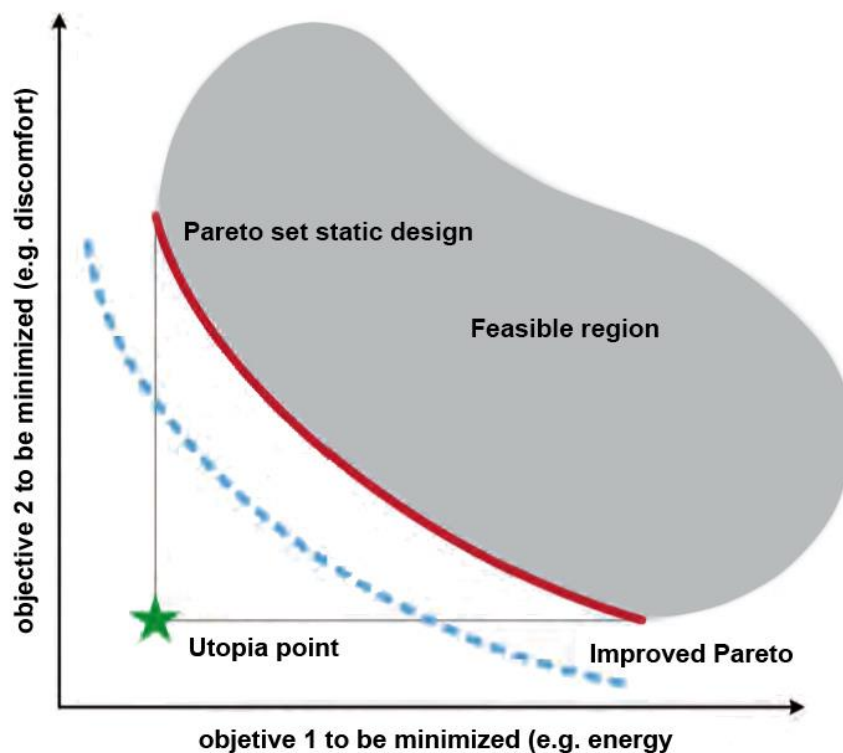

Figure 6. CABS Improved Pareto Set (Boer et al. 2011)

This paper will built on their work but simultaneously consider both; visual and thermal comfort in association with building energy consumption while MOO will be used to evaluate those fabric variables that would offer optimal results to be the base on which an ideal dynamic building will be built. Two steps have been implemented in the process; first, different material properties will be optimised with three objectives in mind: reduce heating & cooling energy and minimize thermal and visual discomfort. Second, the best solutions from optimization results will be used to create an ideal dynamic behaviour by finding the best performance at each timestep of one hour and interchanging material properties accordingly. Chapter 4 (step 1) and Chapter 5 (step 2) will describe the particular methodology used to develop each step and their findings.

3.2. Model Description

Weather: To maximize the performance potential that dynamic buildings could offer, a location with half cooling and heating degree days along the year was looked for. This would mean that most of the time conditions would be outside of the comfort zone towards both margins representing a challenge for energy savings. Latitude and height variations are main determinants for weather conditions; the farther from the equator (specially the northern hemisphere), the more heating is needed. While the closer to the equator (and at low altitudes), the more cooling is required; therefore a proper weather for this work would be in-between the limits of the tropical area and the latitude line form where only heating is required. A weather complying with these parameters was found in Madrid-Spain and the input file obtained from the DOE database.

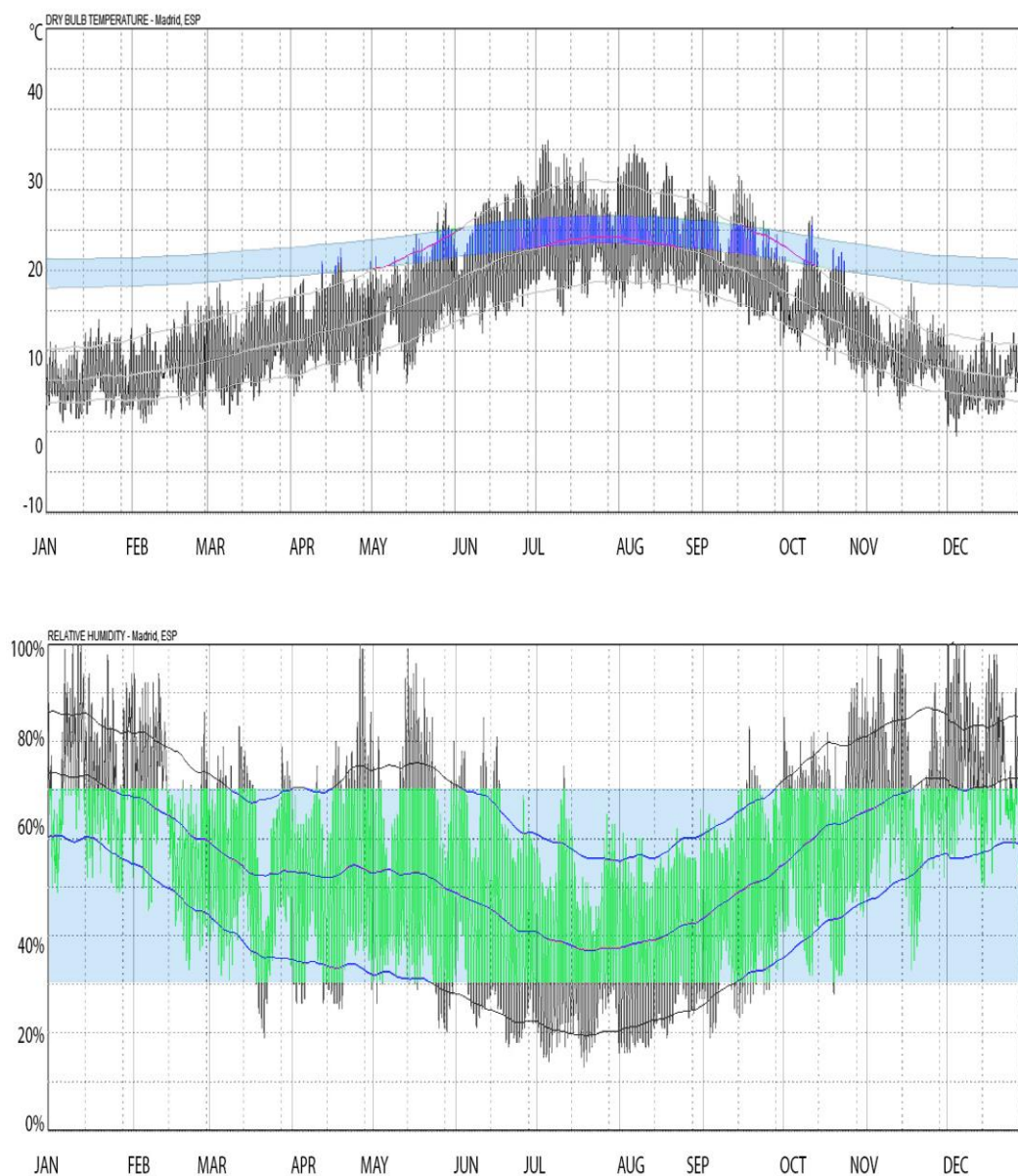

Figure 7. Madrid Dry-Bulb Temperature (°C) & Relative Humidity (%)

Geometry: A simple one zone building was built in EnergyPlus 8 m in length, 6 m wide and 2.7 m height (Area = 48 m Volume = 129.6) with walls oriented perpendicular to each cardinal direction. Due to its northern location an opening was placed at the south maximizing passive solar heat gains in winter. Glazing ratio was kept at 50% with window dimensions of 5.4 m in length and 2 m height starting at 0.35 m above floor level. It is an open plan office for two people with walls and roof exposed to the external environment and no external shading from devices, vegetation or other buildings which could benefit internal conditions for results to show the effects of the fabric itself.

Construction: Glazing and building fabric were built in one layer setting their properties as a variable which could be substituted with values from a specified range according MOO criteria. This was done using jEPlus (Zhang et al. 2011) the parametric tool for EnergyPlus designed to test different model parameters simultaneously. The tool generates commands for EnergyPlus to run and collects the results afterwards. Even though the parametric pre-processor utility has been included in EnergyPlus since recent versions, not requiring coupling it to an external tool anymore; this method was used as the MOO software applied is designed to handle the process through jEPlus.

The idea was to set the ranges by finding the lowest and highest values for each variable existing in the world and extending beyond their limits allowing space for future development in material science (See Table 1). But during the process it was found that EnergyPlus has a limit on what it considers realistic and doesn't allow very low conductivity with very high densities and specific heat capacities therefore conductivity lowest value was set at 0.65 W/m-K, not as low as many insulating materials but lower than what combined layers of an insulated wall could have while the highest boundary for density and specific heat capacity was set at 3000 kg/m³ and J/kg-K respectively. Not as high as desired for material innovation but still in the upper limit of common construction materials.

Table 1. Material Properties Boundaries

Parameter	Lowest	Name	Highest	Name	Construction Ave.*	Name
Conductivity W/m-K	0.024	Air	2,200	Diamond	0.028 - 0.04	Insulations
			2,000	Graphite	0.75 - 1.10	Brick
					100 - 400	Metals
					0.24 - 2.30	Concrete
Density kg/m ³	0.16	Graphene aerogel	22,600	Osmium	10 - 110	Insulations
	0.20	Aerographite	11,340	Lead	1,300 - 2080	Brick
	1.00	Aerogel	3,500	Diamond	2,700 - 8,600	Metals
Specific Heat Capacity J/kg-K					520 - 2,500	Concrete
	100	Wood	4,186	Water	840 - 1,700	Insulations
	440	Bone			800 - 921	Brick
					280 - 880	Metals
				840 - 1000	Concrete	

* Source: CIBSE Guide A

Thicknesses were set fixed using widths common in construction practices (Walls = 0.5, Roof = 0.25, Floor = 0.6 m) leaving the calculated U-value and energy balance to rely entirely on the inherent properties of the material, Table 2 summarizes material input values. For glazing the simplified system in EnergyPlus was used setting U-Factor range in 1 – 6.8 and the SHGC in 0.06 – 0.84.

Table 2. Material Variables Parameters

Parameter	Units	Walls	Roof	Floor
Thickness	m	0.50	0.25	0.6
Conductivity	W/m-K		0.65* - 3000	
Density	kg/m ³		0.1 - 3000*	
Specific Heat Capacity	J/kg-K		100 - 3000*	
Thermal Absorptance			0.1 - 0.9	
Solar Absorptance		0.7	0.7	0.7
Visible Absorptance		0.7	0.7	0.7

* Values not as low or high due to software limitations

Internal Conditions: The zone worked as a mixed mode system where natural ventilation is allowed through windows when indoor dry bulb temperature is above 22 °C but only if the outside temperature is at least 2 °C cooler than indoor conditions. Windows would close if wind speed is above 40 m/s when users normally would shut them to avoid papers to blow up. Mechanical cooling or heating was set to start whenever temperature falls outside 19 to 28 °C. The difference between the thermostat deadband and ASHRAE 55 parameters would be classified as thermal discomfort, even though the range would be acceptable for natural ventilation cases, the challenge is for dynamic buildings to reach the most stringent conditions.

As standard offices the building is fully occupied only on weekdays from 8:00 to 17:00 and partially occupied from 12:00 to 14:00 and one hour before and after working hours, simulating conditions were not everybody lunch at the same time and where a person arrives early or leaves late. Same wise equipment was set to work according to this schedule; the HVAC system operates only on weekdays from 5:00 to 20:00 while lighting operates 50% when there is partial occupation except for lunch time where it keeps operating at 100%. Infiltration flow rate was estimated in 0.5 ACH and internal heat gains according to Table 3.

Table 3. Internal Conditions

Building Type	Density person/m ²	Sensible W/m ²			Fraction Radiant	Latent W/m ²	
		People	Lighting	Equipment		People	Other
Offices	24	5.6	10	15	30%	43%	-

* Source: CIBSE Guide A

4. Multi-Objective Optimization

Designers often use building energy simulations on a scenario by scenario basis; first a solution is proposed, then evaluated and subsequently a new solution is created based on results. This iterative trial-and-error process is time consuming, ineffective and limited as only few scenarios are able to be explored so the best solution is hardly

accomplished. One approach that assesses multiple scenarios is parametric study where the effect of selected design variables is explored by testing some options or all possible solutions. Despite its potential it requires long computing time and high storage capacity (Naboni et al. 2013), not to mention the brute-force necessary to analyse vast amount of results. The other approach is to reduce the number of simulations by implementing the same logic nature has used to evolve species over time; known as evolutionary optimization. Inspired by the Darwinian evolution theory this approach uses evolutionary algorithms (EAs) which randomly select an initial population group, evaluate it and then apply basic genetic operators (reproduction, crossover and mutation) according to the fitness ranking of each individual towards the established objective (Naboni et al. 2013).

The selection of the appropriate optimization algorithm depends on the problem one is looking to solve. A building can be optimized for one or multiple objectives but while single-objective problems offer a unique optimal solution, multi-objective optimizations are problems with conflicting criteria suited for stochastic methods where optimization aims at finding a set of Pareto solutions instead (Wang et al. 2005). A solution is Pareto-optimal if it is dominated by no other feasible solution, meaning that there are no other solutions equal or superior with respect to the objective values (Lartigue et al. 2013). No Pareto solution is better than the other, making the selection up to the trade-off relationship between benefits and their penalties.

MOO requires two stages: optimization of specified objectives for generating one or more Pareto solutions and ranking of trade-offs for selecting the best ones. Both steps can be performed either in sequence (known as Generating techniques), together (setting up trade-off preferences from the beginning) or iteratively (articulating preferences progressively) (Sharma et al. 2012). The algorithm used was NSGA-II which improved the NSGA by introducing elitism; it is of the Generating techniques type and therefore searches Pareto-optimal solutions before ranking them. For most MOO methods it is the ranking procedure the one that encapsulates all the tricks (Zhang 2012).

4.1. EnergyPlus+jEPlus+EA

As described in section 3.2 the parametric solution space was carried out in jEPlus using 14 variables (1- Conductivity, 2- Density, 3- Specific Heat Capacity, 4- Thermal Absorptance, 5- SHGC, 6- Glazing U-Factor). Even though variables for opaque materials were the same, they were treated separately on each surface to allow walls, roof and floor having different properties from each other; turning variables 1, 2, 3 & 4 into 12 independent ones. With the ranges as presented in Table 2 the project resulted in 2.68×10^{17} design alternatives.

The files necessary to run EnergyPlus simulations are linked in jEPlus and once the variables are set, the EAs tool can be coupled with jEPlus to run the optimization. Many tools were found to use EnergyPlus with EAs but were either expensive or came in Java which is a language that architects usually don't speak. jEPlus+EA is a tool that, even though is still in its Beta version, has been designed to reduce the initial effort curve that coupling EnergyPlus with generic optimization tools so far requires (See Figure 8 for process description) .

Crossover rate was set to 1.0, mutation at 0.4 and the population size established in 10 for a maximum of 250 generations executing in total 2,500 simulations. The computing time required was 2 hours and 20 minutes in a 3rd generation dual core processor and 4.3 GB of storage capacity was required. A big improvement compared to what would have been necessary for the 2.68×10^{17} jobs.

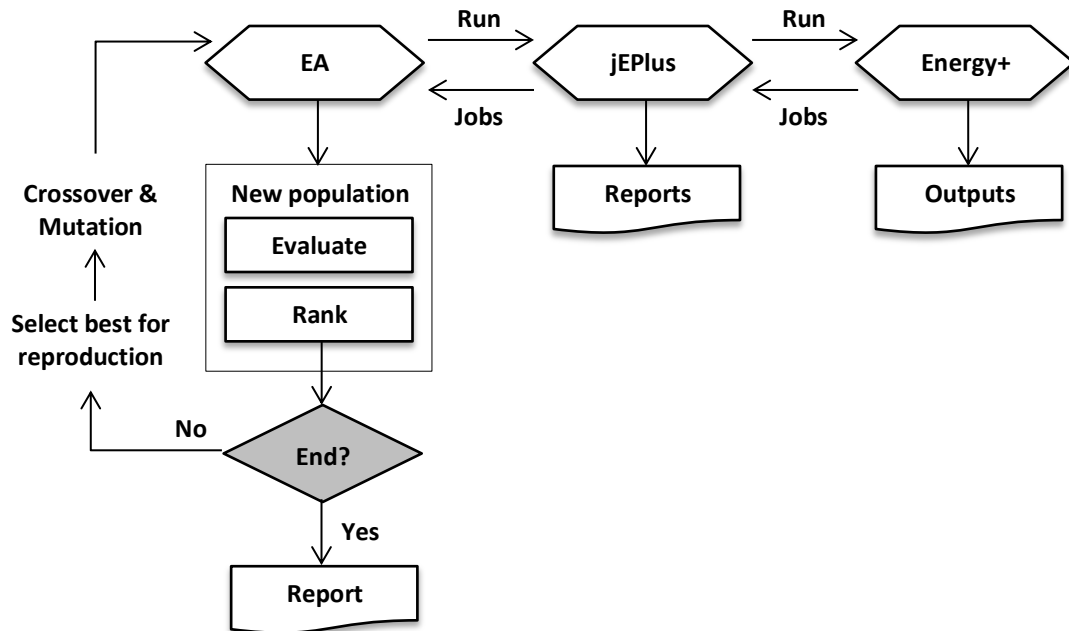

Figure 8. Coupling Flowchart Process

4.1.1. Optimization Results

The three objectives were stabilised after 130 generations showing minor improvements after generation 205 in thermal comfort and energy consumption (See Figure 9). Visual discomfort did not improve after the third generation; limiting the best performance to a minimum of 111.25 hours of glare during the year while thermal discomfort kept in a minimum of 1147.25 hours. Although none of the objectives reached zero; after splitting Total Sensible Energy into cooling and heating it was observed that cooling energy was totally eliminated thus energy's best performance of 4.23 GJ/yr represents heating only.

The multi-objective algorithm found a set of 168 non-dominated individuals in the solution space. Figure 10 shows the Pareto front as displayed between energy and thermal comfort, it exhibits a fan shape where some solutions seem to overlap with dominated individuals due that it is a three objective problem and therefore is solved in three dimensions. It clearly represents the trade-off conflict where energy consumption increases as thermal discomfort minimizes. Figure 11 displays the case between energy and visual comfort where the Pareto front exhibits a non-continuous linear behaviour explained by the fact that glare is not related to heating or cooling energy demand.

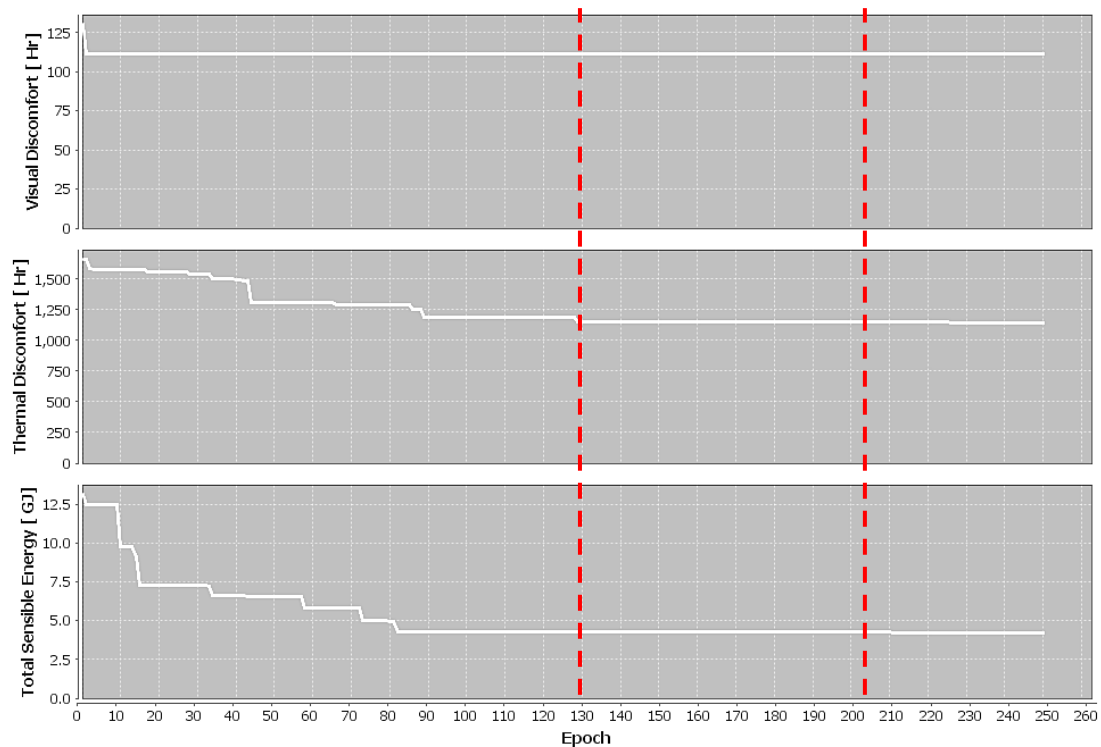

Figure 9. Progress along Generations

The situation between thermal and visual discomfort looked similar but this time a diagonal trend was observed where, even though variables seem not directly related, lower visual discomfort solutions have a higher thermal discomfort penalty (Figure 12). Discomfort glare at a reference point happens due to high luminance contrast between a window and the interior surfaces (EnergyPlus 2013a). For all Pareto cases it occurred in the afternoon from 15:00 to 17:00 on January, November and December; months where the sun has the lowest altitude showing it would be controllable by a simple vertical shading device like blinds or louvers in winter, but not explaining the relation displayed with thermal discomfort.

For a better insight into the design space, Pareto solutions were normalized and plotted in parallel coordinates where each one is represented by a line (See Figure 13). Vertical axes 1 to 14 display the design variables evaluated while axes 15 to 17 the three objectives results. At first glance it clearly shows all cases have the lowest possible U-value on walls ($1.09 \text{ W/m}^2\text{K}$) and roof ($1.75 \text{ W/m}^2\text{K}$) by focusing on the lowest conductivity option of 0.65 W/m-K . This is understandable as these are the fabric surfaces exposed to external conditions bearing the biggest responsibility on energy balance. The wide range in floor conductivity could result from the ground coupling algorithm which is challenging for simulation software (Judkoff & Neymark 1995).

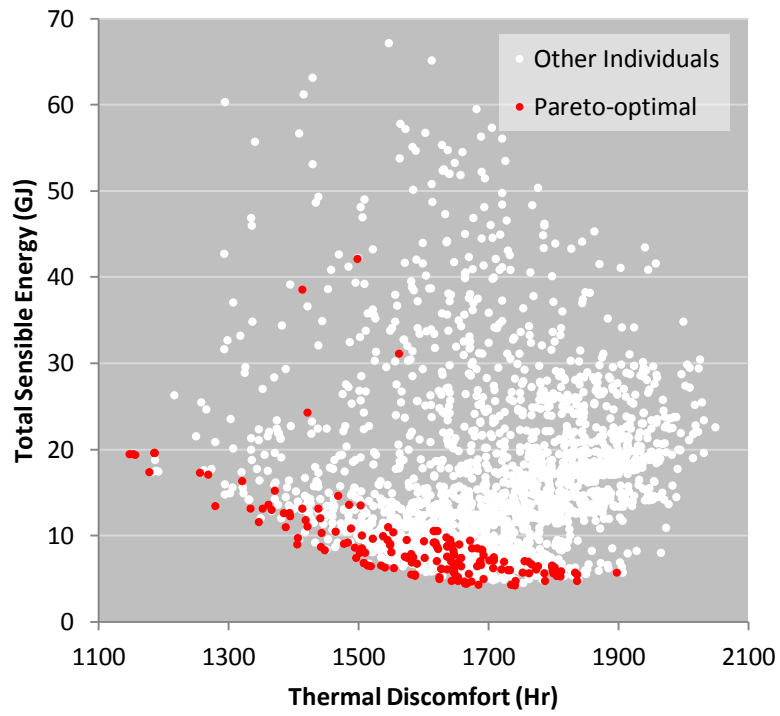

Figure 10. Objective 2 vs. Objective 3

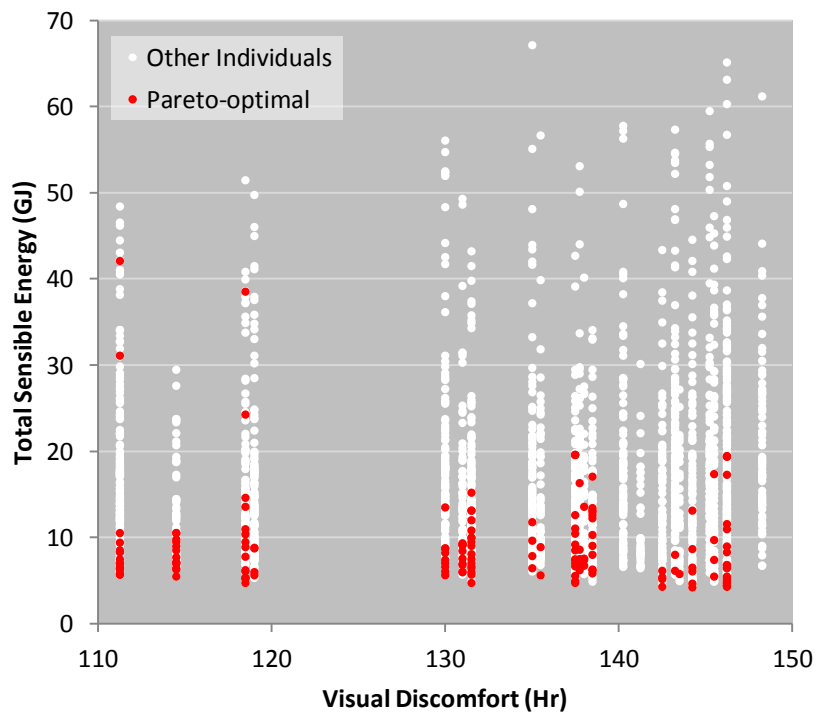

Figure 11. Objective 1 vs. Objective 3

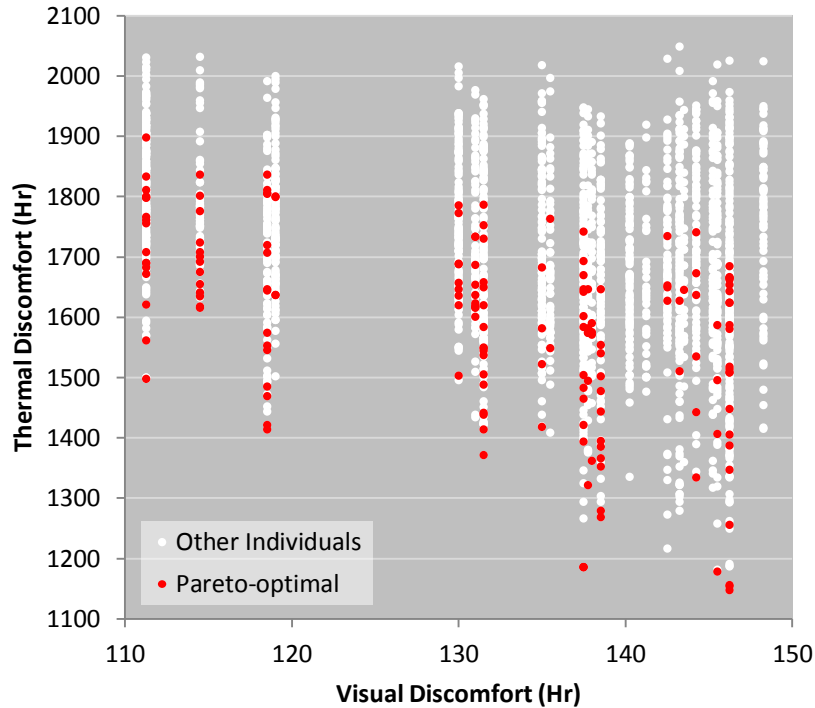

Figure 12. Objective 1 vs. Objective 2

Using the “brushing” technique (Loonen et al. 2011), results were filtered according to the best performance on each optimization objective to visualize subsections of the solution space. Cases with a conditioning energy demand lower than 5 GJ/year are shown in Figure 14 where, besides conductivity, low Glass U-Factor ($1.0 \text{ W/m}^2\text{K}$) and high thermal absorptance (0.8) now appear as determinant variables to minimize heating and cooling needs; ratifying the importance of low U-values on exposed surfaces and solar contributions in minimizing heating demands.

Solutions where thermal discomfort did not exceed 1 400 hr/year are visible in Figure 15; this time ultra-low density on external walls (0.1 kg/m^3) and high specific heat capacity ($2\,700 \text{ J/kg-K}$) on the roof were added to the low U-values. Meaning that external walls are excellent insulators while the roof which is exposed to direct solar radiation most of the time; has good thermal mass properties controlling fluctuations of internal conditions. Basically the walls are behaving close to aerogel (but lighter) while the roof could be asphalt, concrete or stone.

For visual comfort the best solutions were those that did not exceed 120 hours of glare/year (Figure 16). Once these individuals were isolated it was noticed that glazing properties such as very low SHGC (0.06) and very low U-Factor ($1.0 \text{ W/m}^2\text{K}$) were common variables, explaining the relation with thermal comfort in Figure 12 and denoting that while low Glass U-Factor is beneficial for both; low SHGC is convenient for visual but not so much for thermal comfort. Glazing with low SHGC darkens a room avoiding high surface contrast but also reduces solar energy transmittance lowering interior temperatures.

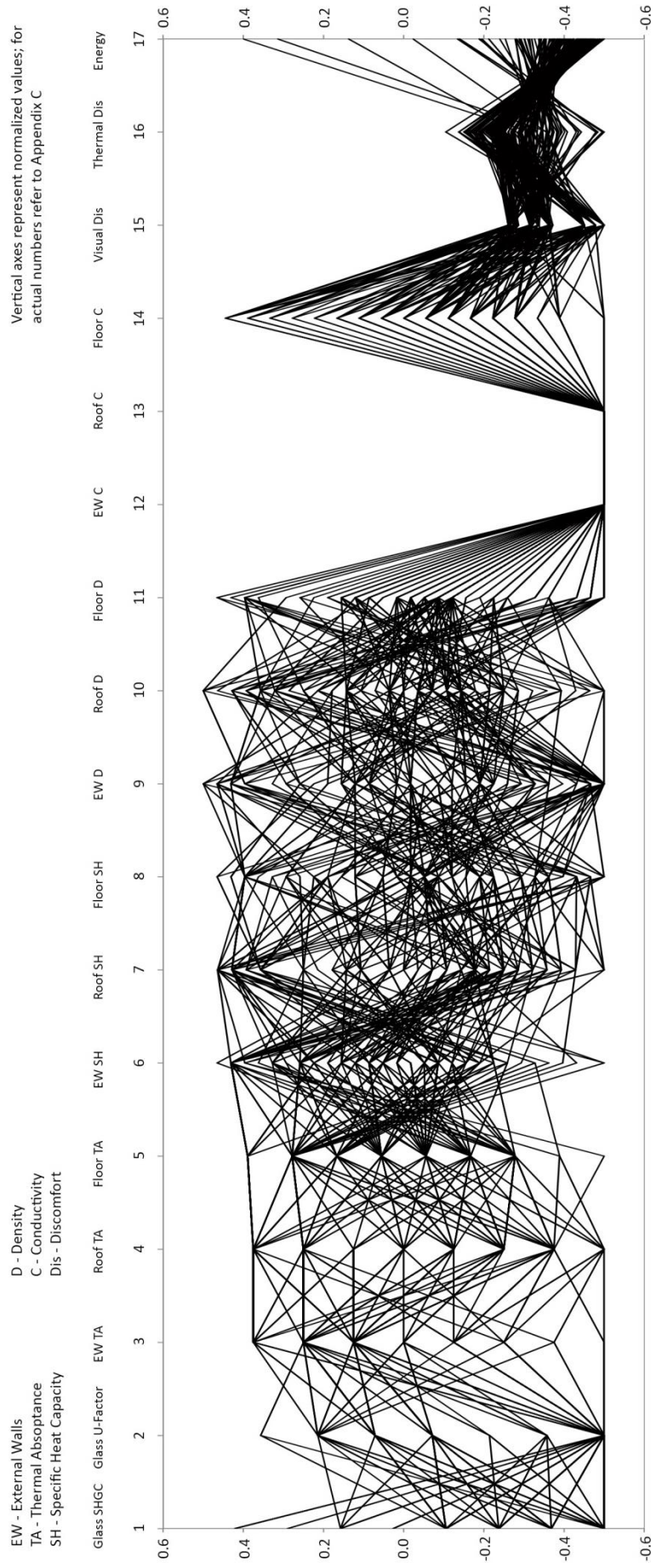

Figure 13. Parallel Coordinates – Pareto Optimal

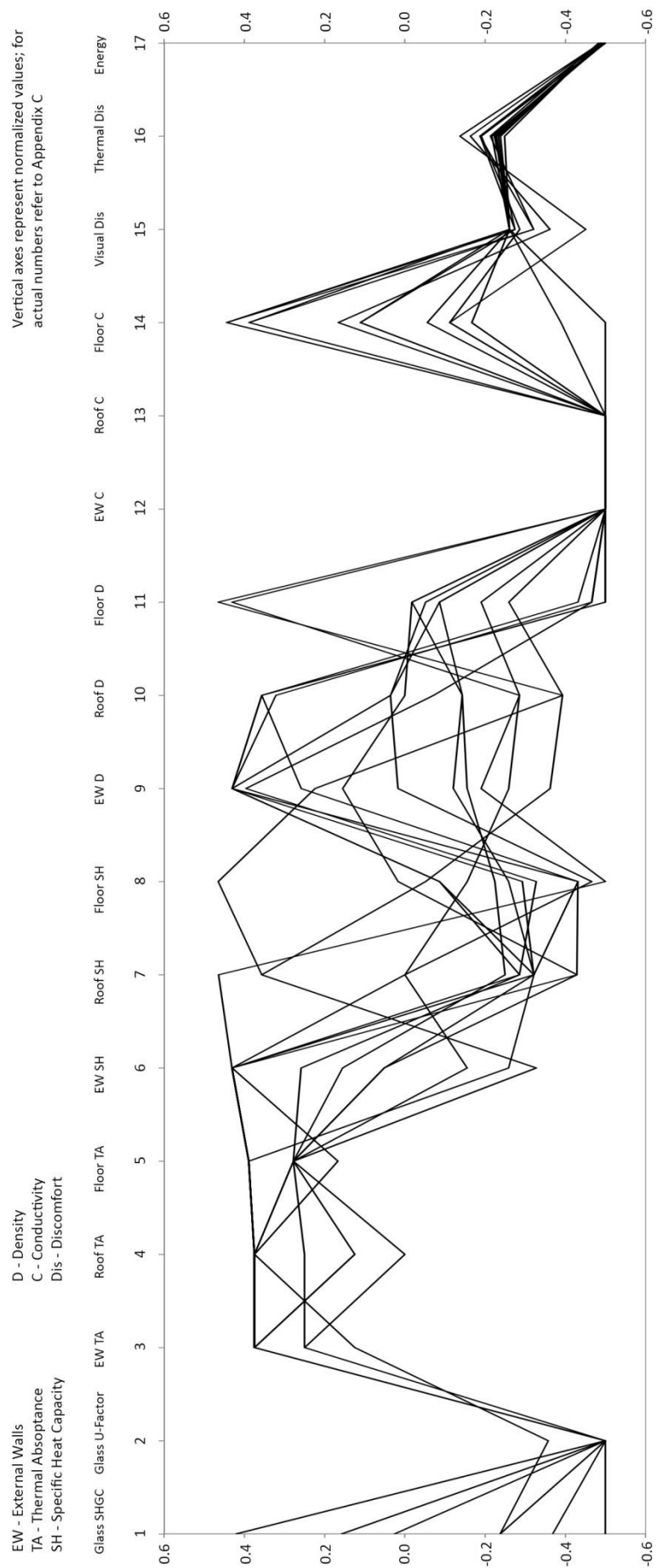

Figure 14. Parallel Coordinates – Best Energy Performance

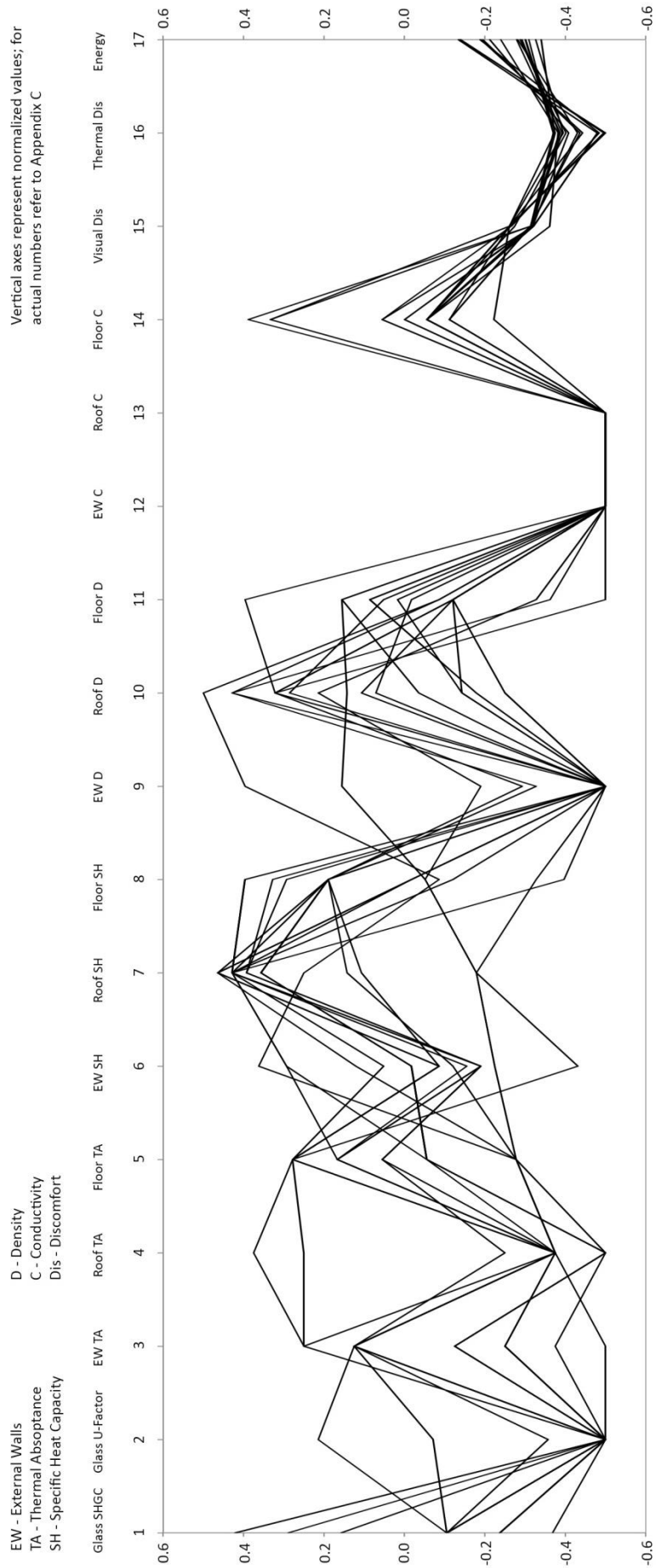

Figure 15. Parallel Coordinates – Best Thermal Performance

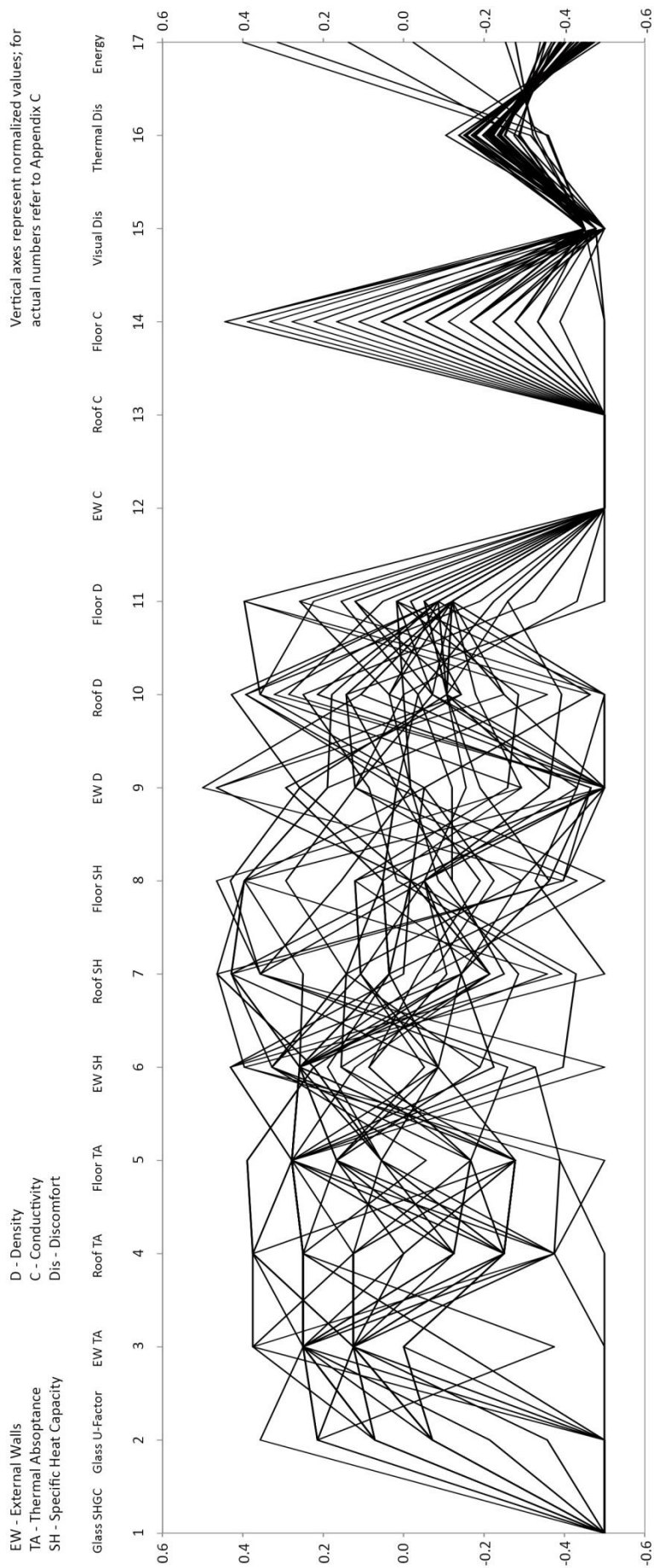

Figure 16. Parallel Coordinates – Best Visual Performance

To properly visualize results; the solution space was plotted in a tridimensional chart picturing the three optimization objectives simultaneously. Dimension Z represents energy, X visual comfort and Y thermal comfort while the gradient scheme indicates where each solution stands in respect to Z with the green colour highlighting Pareto individuals. It is noted that solutions displace parallel to the Y axis in a series of curved rows that reduce as Y values get lower and where optimal solutions lie at the bottom of each row ranging from high to low energy consumption due to the trade-off dilemma previously described.

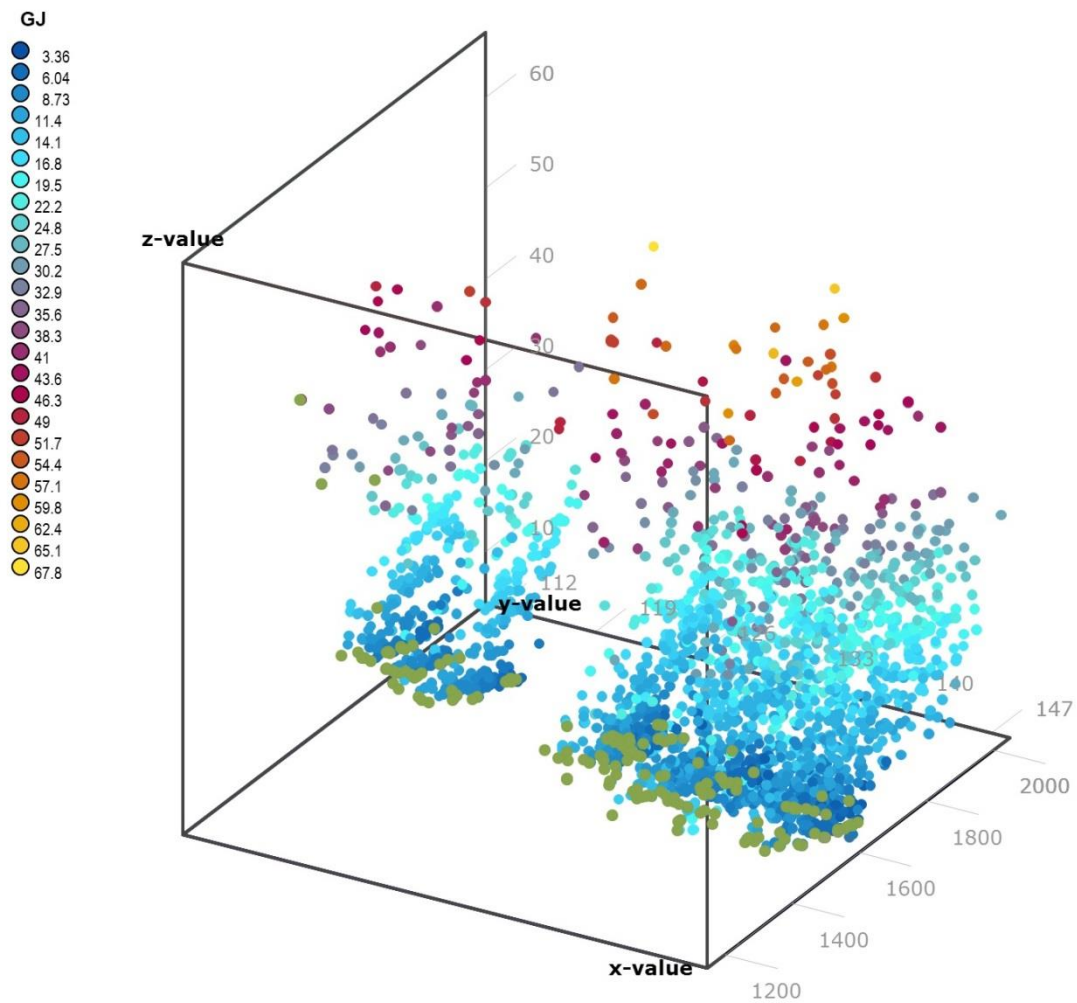

Figure 17. Tridimensional Solution Space

5. Ideal Dynamic Behaviour

In the first step using multi-objective optimization, those fabric properties offering the best performance were revealed along with the trade-off dilemma that exemplifies the inability to meet the objectives simultaneously. Results showed a set of solutions with remarkable performance representing the best that a static building could accomplish. Whereas static buildings can only offer optimal conditions for a limited amount of time; the Ideal dynamic building should be able to have the best fabric properties under any given condition thanks to its mutating ability. The objective of this second step is therefore to find the dynamic behaviour that a building with the conditions described in section 3.2 should have to improve its performance beyond the set of Pareto solutions.

5.1. Building the Fabric

Weather and internal gain inputs at a given timestep possess individual characteristics that would require different material parameters to obtain zero discomfort and energy consumption all the time; basically each timestep needs to be optimized. This could have been done using MOO but running the design space for a period of one hour instead of a year, although it would have signified running 8 760 optimization jobs each one containing 2 500 runs, resulting in 2.19×10^7 simulations and requiring a total 20 411 hours. With this limitation a simplified approach was used where timesteps of the best static buildings were combined to create a dynamic fabric capable to offer optimal performance at each hour of the year. The difficulty relied on how to choose which jobs were the best among the Pareto front as they are all best solutions and no one is better than the other.

Three ranking methods were analysed; the first weighted solutions according to a personal preference where energy consumption was considered the first priority followed by thermal comfort with visual comfort being least important as it would be manageable through blinds or louvers. Jobs where the three objectives had values below the average were filtered obtaining a new list of 17 solutions. A tabular view of the minimum, maximum and average values possible to obtain with this ranking demonstrated that the best possible value for each objective would not be achieved if these jobs were picked as parent ones and the dynamic building would not be the best it could be (See Table 4). A second option used the logic behind the performance indicators set-up, where the objective function was minimized for all three targets meaning that the closer results were to zero, the better the performance would be. Results were added and sorted in ascending order choosing the first five to represent the best solutions. A tabular evaluation showed that with this approach the minimum possible value for visual comfort and energy consumption would not be possible.

Other method used the ranking order proposed by the evolutionary algorithm taking the first five as the best solutions for; as it was mentioned in section 4, the ranking method for most MOO software encapsulates the tricks. The tabular evaluation showed that the maximum and minimum values were included in this sample and that their average was very similar to that of the whole Pareto set. This demonstrated that the combination of these five jobs would generate the best dynamic building behaviour.

Table 4. Ranking Tabular View

Ranking Method	Visual (Hr)	Thermal (Hr)	Energy (GJ)	Jobs
Pareto set	Max	146.25	1897.75	42.14
	Min	111.25	1147.25	4.23
	Average	131.39	1584.43	9.13
Above Average	Max	138.50	1584.25	9.04
	Min	131.50	1478.00	6.20
	Average	136.53	1549.87	7.78
Close to Zero	Max	146.25	1187.50	19.62
	Min	137.50	1147.25	17.37
	Average	144.35	1164.10	19.06
EAs Ranking	Max	146.25	1897.75	42.14
	Min	111.25	1147.25	4.23
	Average	131.85	1558.50	15.67

These five jobs were simulated now in timesteps of one hour, to select which properties to use for the ideal fabric behaviour the “close to zero” method was used. If the sum of the objectives equal zero then that timestep could be considered ideal, in the case more than one job presented the same ideal timestep then the priority would be according to the EAs ranking while if the sum was different than zero then the timestep with the lowest value would be chosen.

5.2. Dynamic Building Results

The percentage of the year parent jobs achieved ideal conditions ranged from 61% to 69%; by having the capacity to adapt its fabric properties the new building exhibited ideal conditions along 75% of the year (See Table 5). When comparing annual energy consumption and comfort performance (See Figure 18), the difficulty to balance conflictive criteria with a static design is noticeable; case 4 exhibits the most balanced performance but whereas thermal discomfort is the best possible value; visual discomfort is the worst case condition. With the dynamic fabric the resulting heating demand was 21.01 GJ/yr while cooling was completely eliminated for a total energy consumption of 437.81 MJ/m². Thermal discomfort was reduced to 880.75 hr/yr and visual discomfort to 111.75 hr/yr. Even thou this solution do not have the lowest energy consumption; it surely represents the best trade-off harmony and percentage of ideal conditions along the year. The Pareto front is a better way to visualize the dynamic building against the best static designs (See Figure 19), its location definitely denotes improved behaviour although it seems that reaching the utopia point described in (Boer et al. 2011) in which optimal comfort is achievable without conflicting with energy consumption remains Zeno’s dichotomy paradox.

Table 5. Static Parents vs. Dynamic Fabric

Objective	EAs Rank					Dynamic Fabric
	0	1	2	3	4	
Ideal Timesteps %	61%	71%	69%	71%	68%	75%
Visual Dis (Hr)	111.25	146.25	111.25	144.25	146.25	111.75
Thermal Dis (Hr)	1498	1508.5	1897.75	1741	1147.25	880.75
Heating GJ/yr	38.78	6.81	5.66	4.23	19.21	21.01
Cooling GJ/yr	3.37	0.00	0.02	0.00	0.28	0.00

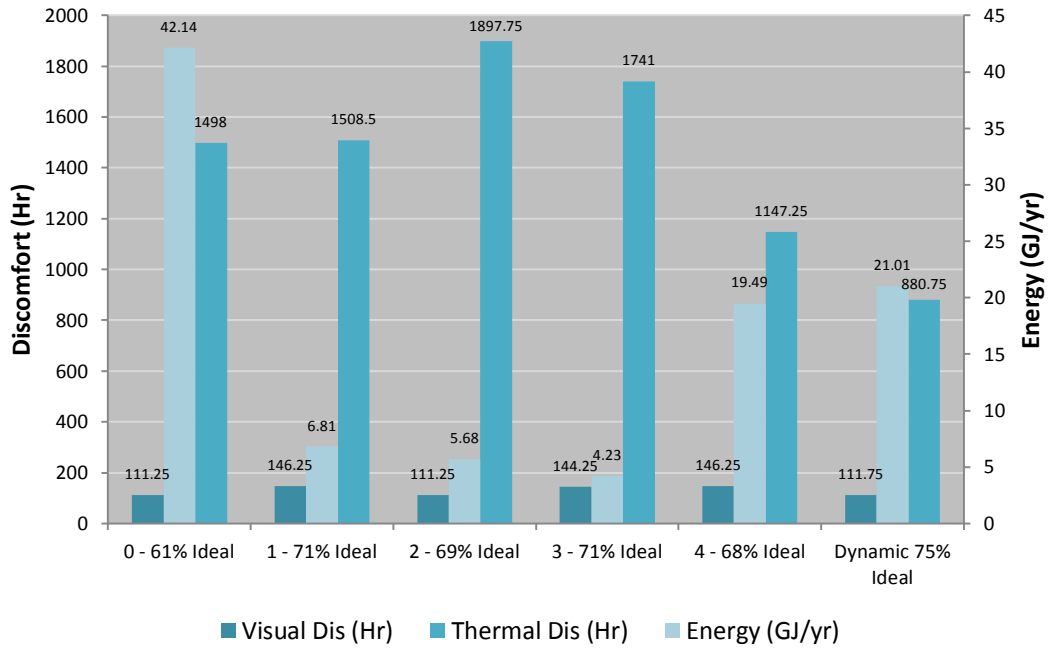

Figure 18. Static Parents & Dynamic Fabric Performance

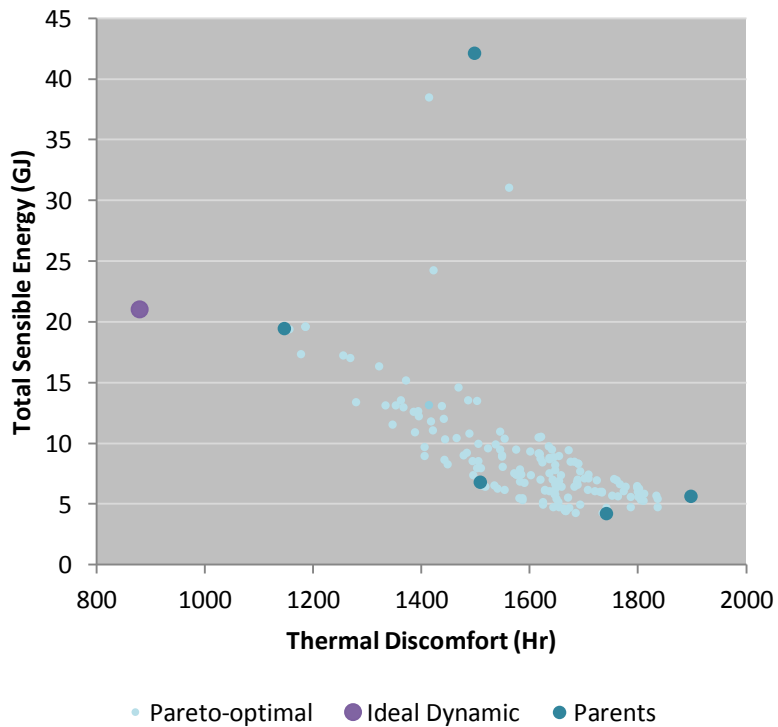

Figure 19. Ideal Dynamic Building vs. Pareto Solutions

6. Conclusions

Pursuing a sustainable built environment requires designers to be able to find an optimal design efficiently. Evolutionary optimization allows Pareto solutions to be identified in a single run whereas conventional trial-and-error methods can hardly come up with the best possible solution. Despite its potential, MOO is not being widely used from the conceptual design phase due to the lack of Architect-friendly tools. Moreover building adaptation is a field in which the boundary between professions gets blurry requiring knowledge beyond what Architecture and Engineering commonly offer with close collaboration from disciplines like Chemistry, Programming and Cybernetics amongst others.

Building performance simulation stands as an indispensable tool to evaluate adaptive behaviours but current software specialize in the analysis of a certain physical domain (Thermal, Visual, Moisture, Acoustic or Indoor Air Quality) with very few exceptions covering a wider range and usually not strong in all. The domain interaction of adaptive buildings inevitably demands performance analysis using different tools presenting simulation coupling as an inevitable step.

Whereas most tools today include dynamic controls for shading and glazing; thermal mass variability still represents the biggest challenge to simulate dynamic conditions requiring advance simulation knowledge and creativity from the person that uses it (Loonen 2010). Fortunately research in this field is starting to reflect; EnergyPlus for example now allows total custom control of the envelope through the Energy Management System (EMS) feature, representing a significant improvement though there is still work needed to overcome the limitations of what software accept as realistic.

The results presented indicate that adaptive behaviour in buildings stand as a promising way to harmonize energy consumption and discomfort levels conflictive nature. Further work would need to evaluate visual discomfort according to illuminance levels instead of the glare index and include electric lighting control into the simulation settings, dimming lights according to daylight contributions and include their electricity use into the energy objective. This way energy consumption would be affected by both comfort indicators closing the relationship between the three variables. An additional step is to translate the analysis into a design proposal and employ a dynamic simulation to compare how close it gets to the ideal behaviour and validate the black box method as an architectural design principle.

References

- Addington, M. & Schodek, D., 2005. *Smart Materials and New Technologies: For Architecture and Design Professions*, Amsterdam: Elsevier.
- An, L. et al., 2012. Estimation of Thermal Parameters of Buildings Through Inverse Modeling and Clustering for a Portfolio of Buildings. In *5th National Conference of IBPSA-USA*. Madison, Wisconsin, pp. 295–305.
- Aschehoug, Ø. & Perino, M., 2009. *Expert Guide Part 2 Responsive Building Elements*, Norway, Italy.
- Bakker, L. et al., 2009. Climate Adaptive Building Shells. *TVVL Magazine*, (3), pp.6 – 11.

- Boer, B. De et al., 2011. Climate Adaptive Building Shells for the future – Optimization with an Inverse Modelling Approach. In *European Council for an Energy Efficient Economy Summer Study*. Presqu'île de Giens, France, pp. 1413–1422.
- De Boer, B., FACET: Facade as Adaptive Comfort-enhancing and Energy-saving Future concept. Available at: <http://www.eosfacet.nl/en/> [Accessed June 27, 2013].
- Boer, B. De et al., 2012. Future Climate Adaptive Building Shells: Optimizing Energy and Comfort by Inverse Modelling. In *8th Energy Forum on Solar Building Skins*. Bressanone, Italy, pp. 15–19.
- Bunge, M., 1963. A General Black Box Theory. *Philisophy of Science*, 30(4), pp.346–358.
- Crespo, A. de A., 2007. *Conceptual Design of a Building with Movable Parts*. Massachusetts Institute of Technology.
- Drake, S., 2007. *The third skin: architecture, technology & Enviroment*, Sydney, Australia: UNSW Press.
- EnergyPlus, 2013a. EnergyPlus Engineering Reference: The Reference to EnergyPlus Calculations. , pp.i – 1348.
- EnergyPlus, 2013b. Input Output Reference The Encyclopedic Reference to EnergyPlus Input and Output. , pp.i–1968.
- Foerster, H. Von, 2003. *Understanding Understanding: Essays On Cybernetics and Cognition*, Springer.
- Glynn, R., 2008. The Wonder of Trivial Machines. *Protoarchitecture: Analogue and Digital Hybrids*, 78(4), pp.13–21.
- Heiselberg, P., 2012. *ECBCS Annex 44 Integrating Environmentally Responsive Elements in Buildings Project Summary Report*, Denmark.
- Heiselberg, P., 2009. *Expert Guide Part 1 Responsive Building Concepts*, Denmark. Available at: www.civil.aau.dk/Annex44.
- Johnson, E.A. & Kulesza, J.D., 2007. System for Allergen Reduction Through Indoor Humidity Control. , 1(12), pp.1–12.
- Judkoff, R. & Neymark, J., 1995. International Energy Agency Building Energy Simulation Test (BESTEST) and Diagnostic Method.
- Lartigue, B., Lasternas, B. & Loftness, V., 2013. Multi-objective Optimization of Building Envelope for Energy Consumption and Daylight. *Indoor and Built Environment*. Available at:

- <http://ibe.sagepub.com/cgi/doi/10.1177/1420326X13480224> [Accessed August 21, 2013].
- Loonen, R., Climate Adaptive Building Shells. Available at:
<http://pinterest.com/CABSoverview/> [Accessed June 26, 2013].
- Loonen, R. et al., 2013. Climate adaptive building shells : State-of-the-art and future challenges. , 25, pp.483–493.
- Loonen, R., 2010. *Climate Adaptive Building Shells, What can we simulate?* Technische Universiteit Eindhoven.
- Loonen, R., Trcka, M. & Hensen, J.L., 2011. Exploring the Potential of Climate Adaptive Building Shells. In *12th IBPSA Conference*. Sydney, Australia, pp. 2148–2155.
- Moloney, 2007. A Framework for the Design of Kinetic Facades. In A. Dong, A. Vande, & J. S, eds. *Computed-Aided Architectural Design Futures Conference*. Sydney, Australia: Springer.
- Naboni, E. et al., 2013. Comparison of Conventional, Parametric and Evolutionary Optimization Approaches for the Architectural Design of Nearly Zero Energy Buildings. In *13th Int. IBPSA Conference*. Chambéry, France.
- Reddy, T.A., 1989. Application of Dynamic Building Inverse Models to Three Occupied Residences Monitored Non-Intrusively. In *Thermal Performance of Exterior Envelopes of Buildings IV*. Orlando, Florida, pp. 654–669.
- Schnadelback, H., 2010. Adaptive Architecture: A Conceptual Framework. In *MediaCityMediaCity*. Weimar, Germany.
- Sharma, S., Rangaiah, G.P. & Cheah, K.S., 2012. Multi-objective Optimization Using MS Excel with an Application to Design of a Falling-film Evaporator System. *Food and Bioproducts Processing*, 90(2), pp.123–134. Available at:
<http://linkinghub.elsevier.com/retrieve/pii/S0960308511000125> [Accessed August 22, 2013].
- Simonson, C.J. et al., 2004. Potential for Hygroscopic Building Materials to Improve Indoor Comfort and Air Quality in the Canadian Climate. In *Buildings IX*. Clearwater Beach, Florida, pp. 1–15.
- Vassela, A., 1983. Third Skin: Building Biology. *International Permaculture Journal*, (14).
- Velikov, K. & Thün, G., 2013. Responsive Building Envelopes: Characteristics and Evolving Paradigms. In *Design and construction of high-performance homes: building envelopes, renewable energies and integrated practice*. Routledge.

- Wang, W., Zmeureanu, R. & Rivard, H., 2005. Applying Multi-Objective Genetic Algorithms in Green Building Design Optimization. *Building and Environment*, 40(11), pp.1512–1525. Available at: <http://linkinghub.elsevier.com/retrieve/pii/S0360132304003439> [Accessed August 7, 2013].
- Wigginton, M. & Harris, J., 2002. *Intelligent Skins*, Elsevier Architectural Press.
- Yazdani, M., Krymsky, Y. & Aweida, C., 2011. Responsive Skins. Available at: <http://yazdanistudioresearch.wordpress.com/> [Accessed August 8, 2013].
- Zhang, Y., 2012. Use jEPlus as an Efficient Building Design Optimisation Tool. In *CIBSE ASHRAE Technical Symposium*. London, UK, pp. 1–12.
- Zhang, Y., Korolija, I. & Stuart, G., 2011. jEPlus. Available at: <http://www.iesd.dmu.ac.uk/~jeplus/wiki/doku.php?id=download:start>.

Prevalence and Evaluation of Bioclimatic Design Techniques used to achieve Low Energy Comfort in Architectural Design Proposals

Adrian Pitts

Department of Architecture and 3D Design, University of Huddersfield,
Queensgate, Huddersfield HD1 3DH, UK
a.pitts@hud.ac.uk

Abstract

This paper analyses responses of ninety-nine students to a design brief for a public building in different regions of China. The research determined the level of understanding and skills development in students who will be the next generation of building designers, procurers and developers. The students were asked to design in a bioclimatic fashion and therefore to consider the building to be as free running as possible, and thus supportive of adaptive comfort principles. The designed solutions were then analysed to determine: the types of bioclimatic technique chosen to be employed; the actual prevalence of use of the techniques in each case; and the successful implementation within the schemes. The results identify barriers to application in design and define productive areas of future comfort research including analysis of interactions between techniques, and the optimisation of whole building solutions. The adoption of bioclimatic design techniques is complementary to adaptive approaches to thermal comfort and reductions in energy use in buildings.

Keywords: bioclimatic design; comfort; climate; students; China

1 Introduction

In order to make substantial reductions in energy consumption by buildings there is a need to encourage two changes to current processes and systems. Firstly, building occupants need to be provided with, and made aware of, the potential to use techniques such as adjustment of their clothing, movement of their position/location within a building space, and control of low or zero energy use systems to modify the internal environment. All these features enable occupants to make optimal use of the thermal conditions available within a building. Secondly, architects and others need to design buildings to match closely with the external climate within which they are situated, and to encompass features that allow occupants to modify the building, and also for it to be robust and adaptable to future climate change. This paper specifically addresses the knowledge needed by designers to achieve the second of these requirements. A further stage of research can also be considered in which the positive and negative interactions between different techniques and technologies in practice should be evaluated holistically in order to understand how to produce an optimised whole-system building outcome.

The method of the research was to issue postgraduate students from a variety of first degrees, but who were working together on an environmental design course, with a brief to design a bioclimatic building. The project brief required the design of a public information/resources centre set in one of ten different Chinese cities; each with a different climate and therefore

each with a different set of constraints. Each student worked collaboratively in forming ideas for solutions for a particular city but ultimately submitted an individual project. Shared precedent case studies were utilised to inform the design process. This paper describes the background to the project and process of analysis of the outcomes and resulting implications for approaches to design education.

2. Building Design and Energy Codes in China

The rapid urbanisation and associated construction development that has taken place in China in recent decades has the potential to cause large increases in building energy consumption. This can arise from three main causes:

- Expectations amongst those moving into newer properties, for higher standards of comfort which are normally associated with intensive heating, ventilating and air conditioning systems.
- A disregard for older, more traditional design techniques both linked to the past and also unable to meet modern needs.
- Building design regulations which impact on certain characteristics of design but which do not exploit the potential for more adaptive approaches and which demand an understanding of bioclimatic design.

A number of codes have been developed over the years for China (for instance Ministry of Construction, 1993), but the size of the country and the complexity of the climate zoning has given rise to difficulties. Seven main zones (or partitions) have generally been identified in the literature, and with each 'partition' having several subdivisions. These are listed below.

1. Partition I: Cold regions type 1 (4 climate divisions). January average temperature ≤ -10 °C; July average temperature ≤ 25 °C.
2. Partition II: Cold Regions type 2 (2 climate divisions). January average temperature of $-10-0$ °C; July average temperature of $18-28$ °C.
3. Partition III: Hot summer and cold winter area (3 climate divisions). January average temperature of $0-10$ °C; July average temperature of $25-30$ °C.
4. Partition IV: Sub-tropical region (2 climate divisions). January average temperature > 10 °C; July average temperature of $25-29$ °C.
5. Partition V: Temperate regions (2 climate divisions). January average temperature of $0-13$ °C; July average temperature of $18-25$ °C.
6. Partition VII: Cold regions type 1 (2 climate divisions) + Cold regions type 2 (1 climate division). January average temperature of $0 - 22$ °C; July average temperature < 18 °C.
7. Partition VII: Cold regions type 1 (3 climate divisions) + Cold regions type 2 (1 climate division). January average temperature of $-5 - 20$ °C; July average temperature ≥ 18 °C; July average relative humidity $< 50\%$.

A discussion paper by Chmutina (2010) identified improvements in codes that had taken place over a number of years but also identified some of the barriers, one of which was a more general understanding of the methods by which energy efficiency in buildings could be improved. The International Energy Agency has reported an increase in the enforcement of building energy codes in China in recent years (IEA, 2013); and a recent online report of work at the Joint Global Change Research Institute (Clickgreen, 2014) suggested substantial savings could be made in a straightforward manner from basic improvements to building regulations.

An approach based solely on upgrading and enforcement of building regulations does not however deal with an underlying problem. Often building regulations result in simplified impacts, such as increases in thermal insulation standards, or changes to the specifications of heating and cooling systems used. A greater potential is to impact on building designers in ways that do not imply technical fixes as the optimum solution, but through changes to design practices that result in better initial buildings; buildings suited to the climate. In this paper it is the last of the three bullet points identified above which is being addressed; in other words, how to improve knowledge and application of bioclimatic design.

The argument advanced in this paper therefore is that if architects and building designers can be given the skills and understanding to enact design techniques in keeping with the needs of the specified climate, the requirement for energy intensive heating and cooling systems is reduced. However in the particular situation of China there are additional complexities in terms of breadth of knowledge and experience required as well as in dealing with a variety of climate types. The research has therefore been carried out to understand better how the building designers of the future currently perceive the opportunities for climate sensitive design and how they enact it. It seeks to discover whether the designers understand climatic classifications; whether they can select appropriate techniques; whether they choose to apply those techniques; and whether the application is fully successful.

3. Bioclimatic Design Techniques

A number of authors over a period of time have both identified the key building bioclimatic design techniques, and also refined them. The Olgyay brothers, Victor and Aladar, in their seminal work 'Design with Climate' (Olgyay and Olgyay, 1963) set in motion design techniques which are still valid in modern architecture. Baruch Givoni in several works ordered the principles and developed algorithms to aid in application (Givoni, 1969, and Givoni, 1998), and Szokolay carried on with this approach to produce yet more organised calculation techniques (Szokolay, 2008).

In all of these works the key parameter was the understanding that it is the combined effect of a number of environmental parameters that affects a person's sense of comfort and that the design of the building itself can enhance or reduce (depending on need) the impact of these parameters. The implications for thermal comfort and energy use are that if more successful utilisation can be encouraged adaptation opportunities are maximised.

Some of the authors identified above have expended efforts to allow visualisation of the impacts of bioclimatic design through the medium of overlays of climate and building information onto psychrometric charts. The resulting diagrams are known as building bioclimatic charts and have both visual appeal as well as underlying analytical value for designers who think through the visual medium.

All of the techniques which follow have been identified as bioclimatic design opportunities; all have been previously well researched and documented, hence below only a brief introduction to each is provided.

3.1 Solar shading

The simplest form of bioclimatic design technique is to provide suitable shading from the excessive heat gain from the sun. In application in design this technique, although simple, must be used with care, particularly where there is a need in winter to allow clear and unobstructed admission of sunlight to counteract the cooler temperatures. In effect its use must be balanced against passive solar heat gain techniques in a calculated way. Many design

projects incorporate solar shading, however they can do so in an unsuitable way, and the onus is on the designer to show how shading systems will operate. In more modern architecture there are opportunities to incorporate such technologies as photovoltaics (PV) into shading devices. In some climates the shading devices may also be used to control wind driven airflows around a building façade.

3.2 Thermal mass

Thermal mass techniques exploit the thermo-physical properties of building materials to absorb and retain heat through the thermal capacity of the material and amount and placement of that material. The combination of capacity and physical amount gives rise to the slightly unscientific term ‘thermal mass’. Thermal mass provides inertia and impacts on energy flows through the more massive components of the building structure; time-lags for heat flows and reductions in temperature swings are typical outcomes of its use. Thermal mass techniques can also be used in conjunction with ventilation options such as night-time purging which uses cooler air overnight to pre-cool building components ready for the warmth of the following day. In the analysis presented later in the paper these two aspects have been decoupled to avoid confusion with application of ventilation techniques on their own.

3.3 Passive solar design

Passive solar design is a well-known and oft-exploited technique used in building design. Conventionally the term applies to the arrangement of windows and other solar absorbing devices such as trombe walls. The simple act of placing windows on a particular façade of a building may indicate a designer seeks the benefits of passive solar design, however for successful implementation careful calculation is also required to ensure overheating either does not occur or is mitigated. Careful use is also required to demonstrate the benefits will be felt at the appropriate time of day for the building type and occupation schedule. It is also a technique which is often incorporated almost without thinking, and which therefore needs to be specifically acknowledged by the designer.

3.4 Natural ventilation

Ventilation of buildings provides simple and effective means of transferring heat between the internal and exterior environment, or vice-versa. Although the thermal capacity of air is small, the volumes of air that can sometimes be induced to move, and the convective impacts of increased air flows (both on humans and on building surfaces), means there is great potential to affect comfort and energy use. Almost all buildings have the potential to use natural ventilation through the opening of suitably placed windows and ventilators. Fully air conditioned buildings are perhaps the only category to actively seek to exclude such ventilation for fear of undermining the operation of the heating, ventilating and air conditioning systems. Natural ventilation is also the theme of investigation in many research projects associated with applying adaptive principles in thermal comfort studies. More summative detail can be found in Nicol et al (2012). Since windows and other openings can be introduced into almost any building, it is the correct placement and functioning of such openings which must be designed with care to enhance natural ventilation potential. Many architectural projects, both by students and from professionals, include the promise of natural ventilation justified by the placement of arrows on sectional and plan drawings. These ‘hopeful arrows’ are often insufficiently supported by calculation and analysis, and therefore can disappoint clients and occupants when expected airflows fail to materialise post- construction. In summary a powerful option, but one that must be shown to operate as required.

3.5 Evaporative cooling

In climates and building situations where the humidity of the air is low but found in conjunction with high ambient temperatures, the evaporation of water into the air has the impact of lowering its temperature. This process can be used directly (where water is evaporated directly into the air entering or already inside a building); or indirectly where the evaporation takes place to cool an intermediate component (which can take a variety of forms). These are techniques which many modern day building designers have little or no direct experience of, and therefore when suggested for incorporation into design will require some preparation. Simple versions such as provision of fountains or bodies of water close to, or inside, a building, can easily be utilised but there is little to guide the designer on the final impact. The impacts of more sophisticated systems are more easily determined but there can be a reluctance to employ them due to lack of detailed understanding.

3.6 Other techniques

In addition to the five basic techniques listed above, there are many other associated options or options which extend the impact of those listed. Though adequate insulation of a building envelope should be straightforward to achieve there are examples of very high levels known as such 'superinsulation'. Another set of techniques is associated with wind protection: this can take several forms such as the partial or full burial of the building in the ground (earth berming), or the provision of external screening using natural or artificial means to achieve wind protection. There are also many varieties of glazing systems incorporating special products or techniques which give greater bioclimatic control. Finally there are numerous hybrid systems which employ both passive and active components to achieve optimum environmental control.

In the analysis which follows later in the paper, the prevalence and use of these techniques is considered.

4. Climate and Cities

China has a more complicated climatic system than many other countries both because of its size and also because of the nature of a significant central area which experiences both hot summers and cold winters. In general climatic design has to deal with more than one significant feature, making the task for architects and other building designers more difficult than in a number of other countries.

Ten cities were used in all in the project which has run so far over two years; brief details of each follow including very basic climatic information.

Beijing is the capital of China located in the northeast of the country. It has a dry, monsoon-influenced humid continental climate characterized by hot, humid summers due to the East Asian monsoon. Winters are generally cold, windy, and dry. Spring may experience sandstorms from the Mongolian steppe, accompanied by rapidly warming, but generally dry, conditions. Autumn, like spring, sees little rain, but is crisp and short. The monthly daily average temperature in January is -3.7°C ; in July it is 26.2°C . Precipitation averages 570 mm annually, 75% falling from June to August

Guangzhou is located in the southwest of the country close to Hong Kong. It is just south of the Tropic of Cancer, and experiences a humid subtropical climate influenced by the East Asian monsoon. Summers are wet with high temperatures, high humidities and a high heat stress index. Winters are mild and relatively dry. There is a long monsoon season, from April

to September. Monthly average temperatures vary from 13.6°C in January to 28.6°C in July. Annual rainfall is over 1,700 mm.

Harbin is located in the far northeast of the country. It has a monsoon-influenced, humid continental climate. The city is known for its cold weather and long winter which is dry combined with very low temperatures (average temperature in January of -18.4°C), which is accompanied by significant sunshine. Spring and autumn are transition periods. Summers can be hot, with a July mean temperature of 23°C and much rainfall with over 500 mm falling in July and August.

Kunming is located in the southwest of the country. It has an elevation 1,900 metres and experiences one of the mildest climates in China, with short, cool dry winters, and long, warm and humid summers. The city has a subtropical highland climate; average temperatures range from 8.1°C in January to 19.9°C in June. The rainy season is May to October; the rest of the year being dry. Rainfall averages 1000 mm, 60% of this falling from June to August.

Lhasa is located in the far west of the country. It has a cool semi-arid climate due to its height above sea level. It experiences cold winters and mild summers, but is somewhat protected from extremes by its valley location. It gets 3,000 hours of sunlight each year. The coldest month is January with an average temperature of -1.6°C and the warmest month is June with a daily average of 16.0°C. Rainfall averages 430 mm; most rain falls in July, August and September.

Sanya is located in the far south of the country. It lies at the southern end of Hainan Island and is the second most southerly city in China. The area has a tropical wet and dry climate with very warm weather all year. The Monsoon is strong, with long wet season but with a significant dry season. The coolest month is January, averaging 21.6°C; the hottest is June, averaging 28.8°C.

Shanghai is located towards the middle of the east coast of the country. It has a humid subtropical climate with four distinct seasons. Winters are cold and damp, with northwesterly winds from Siberia causing nighttime temperatures to drop below freezing. Summers are hot and humid, with an average of 8.7 days exceeding 35°C annually. The city may experience typhoons in summer and the beginning of autumn. The most pleasant seasons are spring (although changeable and often rainy), and autumn (which is generally sunny and dry). Temperatures average 4.2°C in January and 27.9°C in July.

Urumqi is located in the far northwest of the country. It has a semi-arid climate with large differences between summer and winter. The July average temperature is 23.7°C whilst in January the average is -12.6°C. The city is semi-arid, with its summers slightly wetter than its winters. The annual rainfall averages 290 mm.

Wuhan is located in the middle south of the country in a particularly difficult area with hot summer combined with cool winters. It experiences a humid subtropical climate with significant rainfall and four distinct seasons. The city has oppressively humid summers. Spring and autumn are generally mild, while winter is cool with occasional snow. The average temperature ranges from 3.7°C in January to 28.7°C in July. Annual rainfall averages about 1,270 mm falling mainly between May and July.

Xi'an is located in central China a little towards the north. It experiences a temperate climate influenced by the East Asian monsoon, classified on the border between a semi-arid climate and a humid subtropical climate. It has hot, humid summers, cold, dry winters, and dry springs and autumns. Most of the annual rainfall occurs between July and October. Dust storms can occur during March and April. Summer months have frequent but short

thunderstorms. The average temperature ranges from 0 °C in January to 26.6 °C in July, with an annual mean of 13.7 °C.

5. Design Brief and Project

The vehicle for research used in this investigation was to provide a group of students with basic information on climate and bioclimatic design techniques, and then to examine the results of their labours in the production of responses to a design brief. The assignment stated:

“This assignment will provide you with the opportunity to apply bioclimatic design principles to the design of a small institutional building located in a particular climatic zone of China. The goal is to produce a design report which illustrates the appropriate application of bioclimatic design principles for a particular climatic type (e.g., hot-humid, severe cold, continental, etc) and for a particular latitude (which will influence such things as sun angle)... The intention is that you explore what might be practical solutions to the provision of a good quality environment while minimising the use of heating, ventilating, and air conditioning equipment (that is otherwise both capital intensive and expensive to run). ...The brief is for a small community information resources centre (which could include some library facilities).”

Students were assigned to work on one of ten different cities (these have already been identified in section 4 above). As a result of the project ninety-nine students submitted work spread over two academic years. The breakdown of submissions was as follows: Beijing (12 proposals); Guangzhou (12 proposals); Harbin (5 proposals); Kunming (6 proposals); Lhasa (12 proposals); Sanya (12 proposals); Shanghai (12 proposals); Urumqi (6 proposals); Wuhan (11 proposals); and Xi'an (11 proposals).

In each year the design project ran over an intensive period of tuition (nine days) but with preparation time beforehand and a period of approximately four weeks afterwards during which time students refined and produced their design proposals.

Students were allowed and indeed encouraged to make use of analytical techniques some of which used computer based information to determine the optimum bioclimatic features and design principles to utilise. Some of the technology permitted analysis which should have led to direct specification of the technologies and techniques most appropriate to the site and climate. Whilst all students had some access to such information some exploited it better than others and hence a range of outcomes and degrees of success, at least in bioclimatic terms, could be identified. It should be stated that not all of the most well-designed bioclimatic buildings were as successful as architectural spaces, or in terms of aesthetics, or as complete designed solutions.

6. Analysis of Projects

Each one of the ninety-nine submissions was analysed to collect information on the use of the bioclimatic design opportunities. Success or otherwise in the use and application of any single technique on its own is no indicator for the overall success of a design scheme, and indeed some submissions that were strong in one area proved to be weaker in others. In the analysis which follows there is no attempt to grade the projects, simply to analyse use of techniques.

The following list provides the headings under which each scheme was judged.

- Successful completion of a full climate analysis.
- Successful and clear identification of the climatic classification.
- Identification separately and specifically of each of the following techniques as being suitable for use in the assigned climatic location: solar shading; thermal mass; passive solar design; natural ventilation; evaporative cooling; other non-specific techniques.
- Use of each of the specified techniques within the design proposal, either clearly identified or implicitly as a consequence of design decisions taken (that is, in some cases the students did not specifically describe incorporation of the technique, but nevertheless it was present): solar shading; thermal mass; passive solar design; natural ventilation; evaporative cooling; other non-specific techniques.
- Analysis of those techniques used in the design proposal (that is under the same headings which follow) to assess whether each was described and documented in sufficient detail to give confidence in a successful outcome: solar shading; thermal mass; passive solar design; natural ventilation; evaporative cooling; other non-specific techniques.
- Evaluation in each case where a technique had been identified from the climatic analysis as to whether it had been employed in the design.
- Evaluation in each case where a technique had been employed in the design to determine whether it had been used successfully: that is, was it described and documented in sufficient detail to give confidence in a successful outcome.

The data for each of these assessments for each scheme were then considered on a city by city basis and overall.

7. Results

The results of the accumulation of analyses can best be documented in the form of tables. Each table gives the data in summary form for each city/climatic location; and then collectively in the final row. It should be remembered that some of the cities had more submitted schemes than others.

In the first (Table 1), the data relating to the successful climate analysis and then classification of the climate (which should then have made determination of the range of bioclimatic options clearer) are shown.

Table 1: Success of climate analysis and classification

City	Proportion completing full climate analysis	Proportion correctly identifying full climate classification
Beijing	67%	58%
Guangzhou	75%	67%
Harbin	80%	60%
Kunming	83%	100%
Lhasa	67%	42%
Sanya	42%	42%
Shanghai	67%	75%
Urumqi	50%	17%
Wuhan	91%	82%
Xi'an	82%	73%
Overall average	70%	62%

It is clear that even with support not every student was able to complete a full climate analysis. In part this may have resulted from the page limit applied to the report size and in part it resulted from a lack of detail in the easily obtainable climate information: for instance for the remote city of Urumqi data were more difficult to acquire. For the determination of the climate classification, errors may omissions reflect the difficulty in some complex cases of classifying the climate exactly. One can also observe that in some cases even if the analysis was incomplete, the classification was determined correctly.

In table 2 the data show the frequencies of identification of techniques to be used directly from the climate analysis. Clearly not all techniques are applicable in all locations, but if the processes had been carried equally by all, one would expect a polarisation in results showing either acceptance or rejection for each city. This happens in some but not all cases.

Table 2: Bioclimatic design techniques identified from the climate analysis

City	Proportion of proposals selecting specified bioclimatic design technique identified for use from climate analysis performed					
	Solar shading	Thermal mass	Passive solar design	Natural ventilation	Evaporative cooling	Other techniques
Beijing	50%	33%	92%	100%	42%	50%
Guangzhou	58%	25%	17%	100%	25%	17%
Harbin	0%	40%	100%	100%	0%	60%
Kunming	17%	50%	83%	83%	0%	0%
Lhasa	33%	33%	83%	17%	17%	42%
Sanya	17%	8%	8%	92%	0%	17%
Shanghai	0%	17%	42%	92%	25%	8%
Urumqi	17%	33%	83%	33%	17%	67%
Wuhan	0%	100%	73%	100%	0%	0%
Xi'an	0%	73%	100%	91%	45%	0%
Overall average	21%	40%	64%	82%	19%	23%

In table 3 the data showing the actual use/incorporation of the technique into the design are provided. Assuming students obtained results from the climate classification correctly then this should show a direct translation into use from table 2. Though there are a number of similarities there are also clear discrepancies: in some cases techniques are used which were not selected and in others selected techniques are then ignored. This shows a degree of inconsistency and is perhaps something that is linked to how the architectural design progressed, and circumstances in which students for other reasons chose to reject a particular design option, or perhaps to include another. It may also show that some techniques are easier to incorporate, and that the students, as with other designers, chose those techniques they could understand and utilise within a restricted period of time. Note the data represent inclusion not success which is covered in the next table

In table 4 the analysis moves to identify those design techniques which could be explicitly identified as having been implemented successfully. In this case success was not judged by any architectural scale but rather by the provision of sufficient information, drawn, written and calculated, such that confidence might be placed in the design to deliver its intention. As with all such proposals, the actual outcome can only be judged when a building is completed and occupied, however the analysis here is the best proxy available. The table is a little misleading since it shows the overall percentage of successful implementations, when in some cases only a few were attempted, hence the low percentage for evaporative cooling and 'others' categories. Interestingly however, natural ventilation, whilst being both the most

frequently identified technique in tables 2 and 3, fails to deliver at the same level in terms of successful implementation.

Table 3: Bioclimatic design techniques utilised in projects in each city/climate

City	Proportion of proposals incorporating specified bioclimatic design technique into building design proposal					
	Solar shading	Thermal mass	Passive solar design	Natural ventilation	Evaporative cooling	Other techniques
Beijing	75%	17%	92%	92%	8%	50%
Guangzhou	100%	0%	0%	100%	0%	0%
Harbin	0%	80%	100%	100%	0%	60%
Kunming	50%	33%	100%	83%	0%	0%
Lhasa	58%	33%	100%	25%	0%	50%
Sanya	75%	0%	0%	100%	0%	17%
Shanghai	58%	0%	25%	100%	33%	0%
Urumqi	17%	17%	100%	0%	0%	50%
Wuhan	100%	45%	82%	45%	0%	0%
Xi'an	18%	73%	91%	55%	0%	0%
Overall average	62%	26%	63%	72%	5%	20%

Table 4: Bioclimatic design techniques successfully incorporated into designs for each city.

City	Proportion of proposals with specified bioclimatic design technique that were successfully deployed and explained within building design proposal					
	Solar shading	Thermal mass	Passive solar design	Natural ventilation	Evaporative cooling	Other techniques
Beijing	67%	8%	92%	42%	25%	8%
Guangzhou	50%	0%	0%	83%	0%	0%
Harbin	0%	80%	100%	80%	0%	60%
Kunming	50%	50%	67%	50%	0%	0%
Lhasa	50%	42%	100%	8%	0%	33%
Sanya	75%	0%	0%	67%	0%	17%
Shanghai	58%	0%	17%	100%	8%	0%
Urumqi	17%	17%	100%	0%	0%	50%
Wuhan	82%	9%	91%	36%	0%	0%
Xi'an	18%	64%	91%	45%	0%	0%
Overall average	52%	22%	61%	53%	4%	13%

In order to identify issues for discussion and potentially further research, the data for each project were further analysed to consider on a city by city basis if there were specific fault lines. Table 5 attempts to show where either techniques were not identified, but were included anyway by the students, or where identified techniques were not incorporated. The threshold levels applied were 20% of projects in each city. The increased use of solar shading can provide benefits however this seems to be happening by accident rather than choice. Missing use of evaporative cooling is perhaps to be expected as it is a technique less well known to the students and less well documented, however it perhaps also indicates a need for reinforcement in terms of understanding. The omission of thermal mass and natural ventilation in use however could lead to problems of achieving desired bioclimatic outcomes, the more so because the techniques are generally well-known and utilised.

In Table 6, the data are collated to identify cities where particular anomalies seemed to be occurring, that is when a technique was included but not successfully implemented

(according to the definition applied above). From this summary data it seems that two techniques in particular should be analysed in more detail and with follow up to examine impacts but for rather different reasons. The first is the use of solar shading and the second the use of natural ventilation.

Table 5: Evaluations of bioclimatic techniques identified but not used or used but not identified

City	Evaluation of issues: √ = techniques not identified but incorporated anyway X = technique identified but not incorporated					
	Solar shading	Thermal mass	Passive solar design	Natural ventilation	Evaporative cooling	Other techniques
Beijing	√				X	
Guangzhou	√	X				
Harbin		√				
Kunming	√	X				
Lhasa	√			√ and X		
Sanya	√					
Shanghai	√				√ and X	
Urumqi				X		
Wuhan	√	X		X		
Xi'an		√ and X		X	X	
Overall	√	X		X	X	

Table 6: Unsuccessful implementation of bioclimatic design techniques

City	Evaluation of issues: X = technique incorporated into design but not fully successful in implementation in design					
	Solar shading	Thermal mass	Passive solar design	Natural ventilation	Evaporative cooling	Other techniques
Beijing				X	X	X
Guangzhou	X			X		
Harbin						
Kunming	X		X	X		
Lhasa						
Sanya					X	
Shanghai						X
Urumqi						
Wuhan	X	X				
Xi'an						
Overall	X			X		

8. Conclusions

The information presented in this paper and therefore the conclusions which can be drawn all relate to student project work rather than professional building designs. Nevertheless such students are the practitioners of tomorrow and it is important they are able to understand climatic analysis and the appropriate choices of building bioclimatic design techniques.

The following summary conclusions may be drawn:

- Designers who have access to a wide variety of climate information need further guidance to ensure correct assessment of classification of climate and thus are enabled to make appropriate selection of bioclimatic design techniques.
- Designers should be encouraged to document choices available and reasons for selection or rejection of a technique in a particular situation.
- Accidental inclusion or exclusion of a technique needs to be explained both to avoid use of inappropriate options for design, and to ensure all the necessary techniques are included as an expectation in a design proposal.
- Bioclimatic design techniques are known by most designers but the detail of their functional operation needs to be better communicated, particularly for some of the less well known options or those where there maybe conflicts between techniques.
- Designers should be encouraged at the end of the design process to compare outcomes with expectations of use, and to justify reasons for variation.
- The particular aspects of bioclimatic design that deserve attention are as follows:
 - use of solar shading should not be a by-product but something explicitly designed;
 - thermal mass techniques are often considered but then become lost in the architecture of the design – this should be avoided;
 - natural ventilation is often assumed to be taking place but the means for it to happen need to be more calculated and determined to be classed as successful;
 - designers who specify evaporative cooling need to understand the processes more clearly.

In completing the analysis it is also clear that a further stage of research and student interaction has potential to improve outcomes – that is a reflective analysis stage on completion of the design. At this point it would be possible to engage with analysis of positive reinforcement or negative interactions occurring between the climate and the chosen techniques and between adopted techniques themselves. This could also then be used to optimise overall building performance.

The use of bioclimatic design techniques is increasing in popularity and can open up opportunities for more adaptive approaches to create thermal comfort in more naturally conditioned buildings. In order to achieve this however, designers need to be equipped with more detailed understanding and skills so as to avoid unfulfilled expectations. There is much optimism for the future given the potential displayed in the project analysed for this research, but even more effort is required to complete the task.

References

Chmutina, K. 2010. *Building Energy Consumption and its Regulations in China*, Discussion paper 67, China Policy Institute, The University of Nottingham, UK.

Clickgreen, 2014. China could cut energy use by 22% through efficient building plans. Available online at <http://www.clickgreen.org.uk/research/trends/124152-china-could-cut-energy-use-by-22-through-efficient-building.html> [accessed 30 January 2014]

Givoni, B. 1969. *Man, Climate and Architecture*, Elsevier Press.

Givoni, B. 1998. *Climate Considerations in Building and Urban Design*, John Wiley & Sons.

IEA, 2013. *Modernising Building Energy Codes*, International Energy Agency

Ministry of Construction, 1993. *National Standard: Building climate zoning standards – Standard of Climatic Regionalization for Architecture*, GB 50178-93, State Bureau of Technical Supervision/ Ministry of Construction.

Nicol, F.; Humphreys, M.; Roaf, S. 2012. *Adaptive Thermal Comfort: Principles and Practice*; Routledge: Abingdon, UK.

Olgyay, V. and Olgyay, A. 1963. *Design with Climate*, Princeton University Press. Szokolay, S. 2008. *Introduction to Architectural Science*, Routledge, 2nd Edition.

Field evaluation of the performance of a radiant heating/cooling ceiling panel system

Ryozo Ooka¹, Rongling Li², Togo Yoshidomi² and Bjarne W. Olesen³

1 Institute of Industrial Science, the University of Tokyo, 4-6-1 Komaba, Meguro-ku, Tokyo, Japan, ooka@iis.u-tokyo.ac.jp

2 Graduate School of Engineering, the University of Tokyo

3 Intl. Centre for Indoor Environment and Energy, Technical University of Denmark

Abstract

For testing different engineering solutions for energy-efficient buildings, a low-energy building was built at the University of Tokyo as a pilot project. In this building, a radiant heating/cooling ceiling panel system is used. This study aims to not only clarify the system performance but also to share our experience and results for them to serve as a reference for other similar projects. Here, the system performance in relation to its heating/cooling capacity and thermal comfort has been evaluated. The heat transfer coefficient from water to room was 3.7 W/(m²K) and 4.8 W/(m²K) for heating and cooling, respectively. The thermal comfort measurement showed that the air and operative temperature distributions in the room were highly uniform. In both heating and cooling, the PMV was higher than -0.5 and less than +0.5 and the PPD was less than 10%. A category B thermal environment was obtained using the radiant ceiling heating/cooling system.

Keywords: Radiant heating/cooling ceiling; overall heat transfer coefficient; heat use efficiency; thermal comfort; in situ

1. Basic theory

Figure 1 shows the cross section of the testing room with a suspended ceiling. In this figure, θ_s is the mean surface temperature of the radiant panels; θ_u , the mean air temperature of the plenum; θ_o , the room's operative temperature as measured in its middle at a height of 0.7 m above the floor; θ_w , the mean heating/cooling water temperature; q_w , the heating/cooling capacity of water [W/m²]; q_1 , the heat flux from the water to the room [W/m²]; and q_2 , the heat flux from the water to the plenum [W/m²].

This study aims to evaluate the in situ performance of the system, including the overall heat transfer coefficient from the water to the room U_{wo} and from the water to the plenum U_{wu} , and to analyze the heat loss. Because no standard exists for the evaluation of in situ radiant heating/cooling ceiling panel systems, we create a resistance model for the radiant ceiling according to ISO 11855-2 (2012) and EN 14240 (2004). This model is shown in Figure 2, and it is governed by the following equations:

$$\theta_w = (\theta_{w,in} + \theta_{w,out})/2 \quad (1)$$

$$U_{wo} = q_1 / (\theta_w - \theta_o) \quad (2)$$

$$U_{wu} = q_2 / (\theta_w - \theta_u) \quad (3)$$

$$q_2 = q_w - q_1 \quad (4)$$

$$q_w = \rho c m (\theta_{w,in} - \theta_{w,out}) / A_p \quad (5)$$

$$R_{wo} = 1/U_{wo} \quad (6)$$

$$R_{wu} = 1/U_{wu} \quad (7)$$

Here, $\theta_{w,in}$ and $\theta_{w,out}$ are the supply and return water temperatures, respectively [$^{\circ}\text{C}$]; m is the water flow rate [m^3/h]; ρ and c are the water density [kg/m^3] and specific heat capacity of water [$\text{kJ}/(\text{kgK})$], respectively; A_p is the area of the panels [m^2]; R_{ws} is the thermal resistance between the fluid and the radiant panel surface; R_{so} and R_{su} are the thermal resistances from the panel surface to the room and the plenum, respectively; and R_{wo} and R_{wu} are the thermal resistances between the water and the room and between the water and the plenum, respectively. The unit of thermal resistance is [$\text{m}^2\text{K}/\text{W}$].

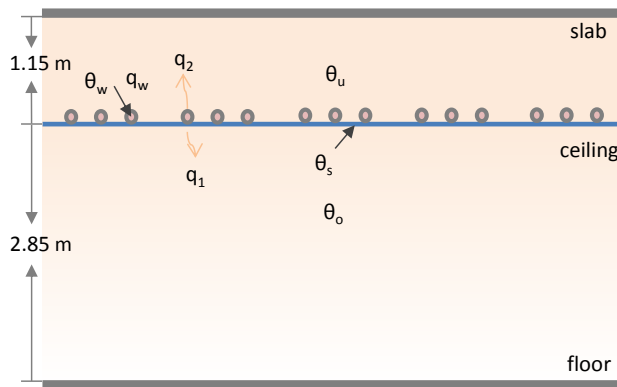

Figure 1 Cross section of testing rooms

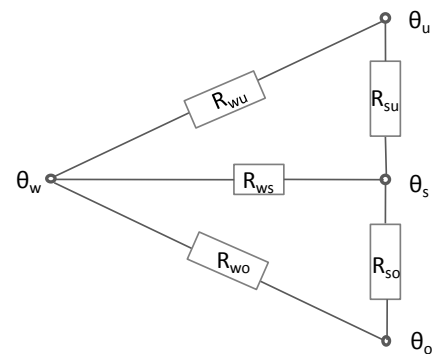

Figure 2 Resistance model for radiant panel

To verify the accuracy of the measurements, we followed ISO 11855-2. The ISO 11855 series is applicable to water-based embedded surface heating and cooling systems in residential, commercial, and industrial buildings, and it is applicable to systems integrated into the wall, floor, or ceiling construction without any open air gaps because the heat transfer coefficient between the radiant surface and the room is not related to the structure of the radiant body. The recommended heat transfer coefficient can be used as a reference value for our study. This standard recommends theoretical models for calculating the heat flux between the ceiling and the room as

$$q_1 = U_{so}(\theta_s - \theta_o) \quad (8)$$

Here, U_{so} is the heat transfer coefficient between the radiant surface and the room, which combines convection and radiation. Its value is $6 \text{ W}/(\text{m}^2\text{K})$ for ceiling heating systems. For ceiling cooling systems, it is given as follows:

$$q_1 = 8.92(\theta_s - \theta_o)^{1.1} \quad (9)$$

2. Test description

2.1 Testing system

The tested radiant cooling/heating panel ceiling system consists of aluminum panels (area: 1.26 m² (2.1 m × 0.6 m)) that are coated on the bottom surface, as shown in Figure 3. The main characteristics of the radiant panel are presented in Table 1. Although holes are present on the surface of the panel, a black painted aluminum board is placed behind the entire panel, and the areas of the holes are included in the calculation of the radiant area. Above the aluminum board, the entire suspended ceiling is covered with insulation to prevent upward heat flux entering the plenum.

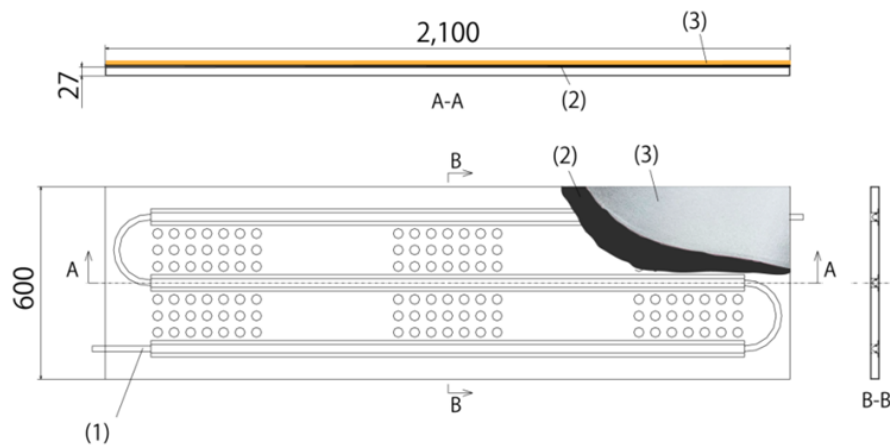

(1) Polybutene pipe (2) Aluminum board (3) Insulation board

Figure 3 Radiant panel

Table 1 Main characteristics of tested radiant panel

	characteristic
(1)	polybutene; internal diameter: 13 mm, external diameter: 18 mm
(2)	0.25 mm
(3)	10 mm glass wool

2.2 Testing room

Classrooms M and L on the 4th floor of 21KOMCEE were used as testing rooms (Ryozo et al, 2013). Figure 4 shows the position and floor plan of the testing rooms. The ceiling area of classroom M is 103.7 m², with 45% area covered by panels. The ceiling area of classroom L is 174.1 m², with 40% area covered by panels.

Each room has one hydronic system, and these two systems are connected in parallel to a water-to-water heat exchanger, where the water of the panel system exchanges heat with the hot/cold water from the energy supply. As seen in Fig. 6, the supply/return water temperatures and the water flow rate are measured at the outlet/inlet of the heat exchanger by sensors TE-1, TE-2, and FM, respectively. Because the conditions in the two rooms were identical during the measurements, their supply/return water temperatures were assumed to be identical. Here, classroom M was chosen as the main room for measurement.

Figure 5 shows the ceiling description and the panel positions in classroom M. 72 panel units (2100 × 600 mm) are installed in three parallel modules.

The dimensions of classroom M are as follows:

Length: 10.8 m (Figure 5)

Width: 9.6 m (Figure 5)
 Height: 2.85 m (below ceiling)
 Height of ceiling plenum: 1.15 m (above ceiling)

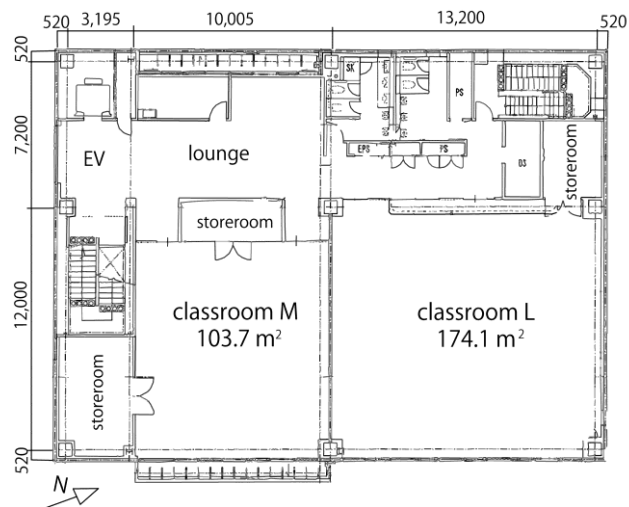

Figure 4 Testing room position and floor plan

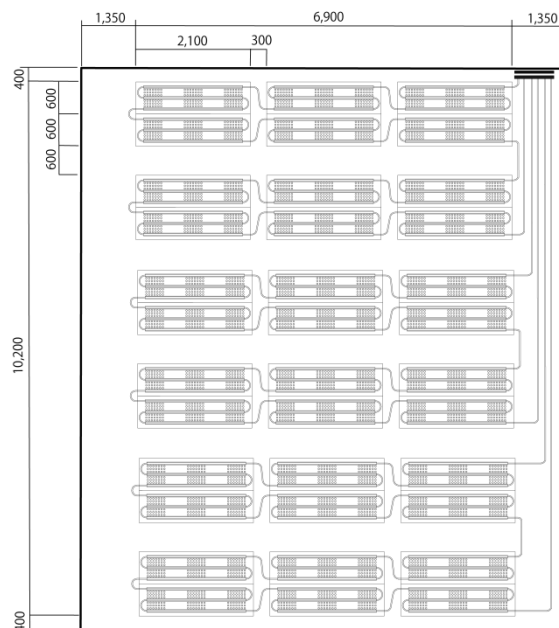

Figure 5 Ceiling description and panel positions in classroom M

The building has a well-insulated reinforced concrete structure. The external wall of room M faces east, and the wall has a double skin system with movable louvers. This system's U value has been measured to be 1.45 W/(m²K) (Shida et al, 2012).

2.3 Water circuit control

The supply water flow rate and temperature were controlled during the measurements. Figure 6 shows the water loop. The supply water flow rate and temperature were controlled by adjusting the position of valves MV-1 and MV-2, respectively. MV-2 is a volume control valve of the water loop that is connected with the heat supply equipment.

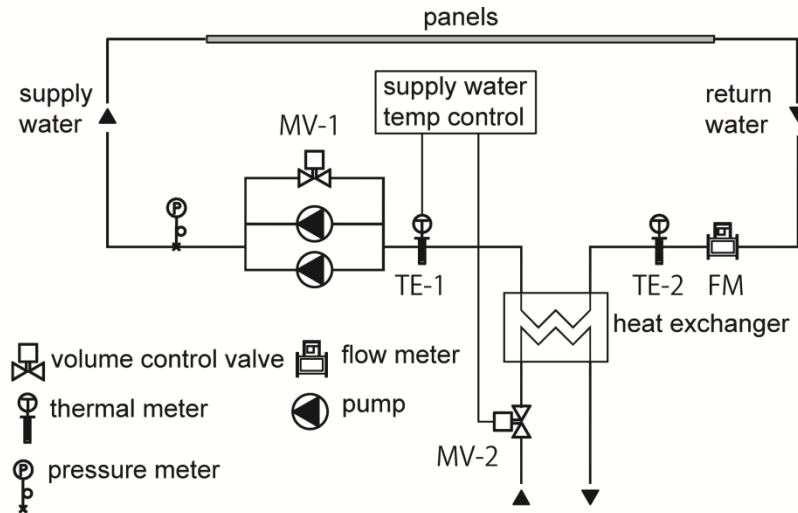
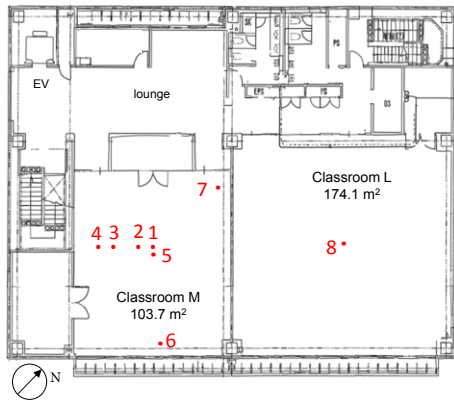

Figure 6 Water hydraulic system control

2.4 Instruments and sensors

As seen in Figure 7, sensors were placed at positions 1 to 7 in room M and a θ_o sensor was placed at position 8 in room L. Table 2 lists the instruments and sensors used in the measurements. For our measurements, we used thermography to check the surface temperature profiles of the ceiling and to find suitable locations for the thermocouple sheets (THSs) and heat flux meters (HFMs). From the thermographs of each panel, we observed that the temperature at the center of the panel was equal to the average temperature of the entire panel. Thus, we decided to place the sensors at the centers of the panels, as seen at locations 1, 2, 3, and 4 (Figure 7 (b)). HFMs were pasted on the panel surfaces to measure both the surface temperature θ_s and heat flux q_1 . To verify the accuracy of the measured values, THSs were also pasted at locations 1, 3, and 4 for data comparison. At the center of the room, location 5, we set 6 thermocouples at 0.1 m, 0.7 m, 1.1 m, and 1.7 m above floor level, 0.1 m below ceiling, and 0.1 m above ceiling to measure the vertical air temperature profile. Because a 3-to-5-cm-diameter grey globe sensor accurately presents the operative temperature θ_o , we used 4-cm grey painted ping-pong balls as operative temperature sensors (Simone, 2007; ISO 7726, 1998). To obtain the horizontal profile of θ_o , we placed the globe sensors 0.7 m above the floor level at the center of the room (location 5), on the window side (location 6), and at the corner of an interior wall (location 7).



(a) Sensor locations



(b) Radiant ceiling panel system and sensors

Figure 7 Sensors and locations

Table 2 Instruments and sensors

Instrument/sensor	Measurement	accuracy
Thermocouple sheet (THS)	Surface temperature	$\pm 0.5^{\circ}\text{C}$
Heat flux meter (HFM)	Surface temperature & heat flux	$\pm 0.01^{\circ}\text{C}$ $\pm 0.01 \text{ W/m}^2$
Thermography	Surface temperature	$\pm 2.0^{\circ}\text{C}$
Thermocouple	Vertical air temperature profile	$\pm 0.5^{\circ}\text{C}$
Globe sensor	Horizontal operative temperature profile	$\pm 0.5^{\circ}\text{C}$
Pt100	Water temperature	JIS(1997) class A $\pm (0.15 + 0.002 t)^{\circ}\text{C}$
Electromagnetic flow meter	Water flow rate	0.25–0.5% of rate

Measurements of the supply water mass flow rate, supply water temperature, return water temperature, and ambient temperature were performed using the sensors of the building management system.

2.5 Measurement protocol

The heating mode measurements were carried out during March 18–23, 2013. Because the outdoor temperature was almost 20°C during the daytime, it was too warm to operate the heating system. It was also desirable to avoid interference from solar radiation. Thus, the measurements were carried out during the night time from 19:00 to 7:00. The cooling mode measurements were carried out during September 10–13, 2013, from 8:00 to 17:00. Table 3 lists the cases and outdoor temperatures during the measurements. H1–H4 are the heating measurement cases and C1–C3 are the cooling cases.

Table 3 Cases & outdoor temperature

	H1	H2	H3	H4	C1	C2	C3
supply water temperature [$^{\circ}\text{C}$]	40	40	28	35	18	18	20
water flow rate [m^3/h]	2.0	2.0	2.0	2.0	2.0	2.0	2.0
outdoor temperature [$^{\circ}\text{C}$]	16–20	7–13	13–17	12–16	26–32	23–28	28–32

3. Results

The data collected in the steady state (EN 14240, 2004) are used for the analysis.

3.1 Heat flux and heat transfer coefficient

(1) Heat flux measurements and uncertainty analysis

The heat flux q_1 was measured using HFMs and calculated using Eq. (8) for heating mode and Eq. (9) for cooling mode, respectively. The result of this calculation was compared with the experimental data to validate the measurements. Figure 8 (a) shows the steady state (23:00 to 6:00) values for H2 and (b) shows the steady state (12:00 to 17:00) values for C3. For case H2, the mean value of the measured heat flux ($q_{1,meas}$ in the figure) is 50.8 W/m^2 , and the heat flux calculated from Eq. (8) ($q_{1,calc}$ in the figure) is 49.0 W/m^2 . In the calculation, θ_s is the mean value of the temperatures measured at locations 1–4 and θ_o is measured at location 5.

Table 4 lists the measurement results for all the cases. The differences between $q_{1,meas}$ and $q_{1,calc}$ are less than 4% for H1, H2, and H4 and $\sim 7\%$ for cases C1–C3. Good agreement was found between the theoretical heat flux and the measured data.

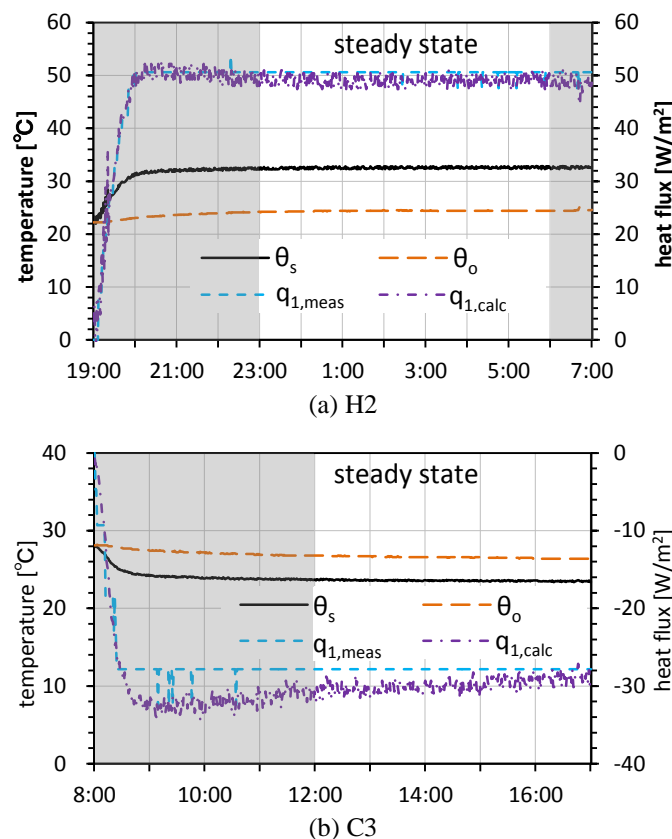

Figure 8 Measurement results and calculation results for heat flux

The deviation for H3 is significant and that for cases C1–C3 is higher than in the three heating cases. To clarify the reason for this, the measurement uncertainty is evaluated according to the JCGM 100 (2008) standard. Considering the accuracy provided by the instrument specifications is type B uncertainty and taking into account a coverage factor of 2, the combined uncertainty is calculated. For the temperature difference $\theta_s - \theta_o$, it is $\pm 0.5^\circ\text{C}$, and for the measurement heat flux $q_{1,meas}$, it is $\pm 0.02 \text{ W/m}^2$. The uncertainty of $\theta_s - \theta_o$ then translates into the uncertainty of $q_{1,calc}$, which is given

by Eqs. (8) and (9). As a result, $q_{1,calc}$ has a distribution with upper and lower bounds of $\pm 3.0 \text{ W/m}^2$ for heating cases and approximately $\pm 6.0 \text{ W/m}^2$ for cooling cases.

Table 4 Accuracy of measured heat flux

	H1	H2	H3	H4	C1	C2	C3
$\theta_s - \theta_o$ [°C]	8.2	8.2	2.5	5.9	-3.7	-3.4	-3.0
Measurement heat flux $q_{1,meas}$ [W/m ²]	49.8	50.8	18.2	35.0	-35.4	-32.0	-27.8
Calculated heat flux $q_{1,calc}$ [W/m ²]	49.0	49.0	15.0	35.3	-38.0	-34.5	-30.0
Relative deviation $ q_{1,meas} - q_{1,calc} / q_{1,calc}$	1.6%	3.6%	21.2%	0.8%	7.0%	7.2%	7.3%

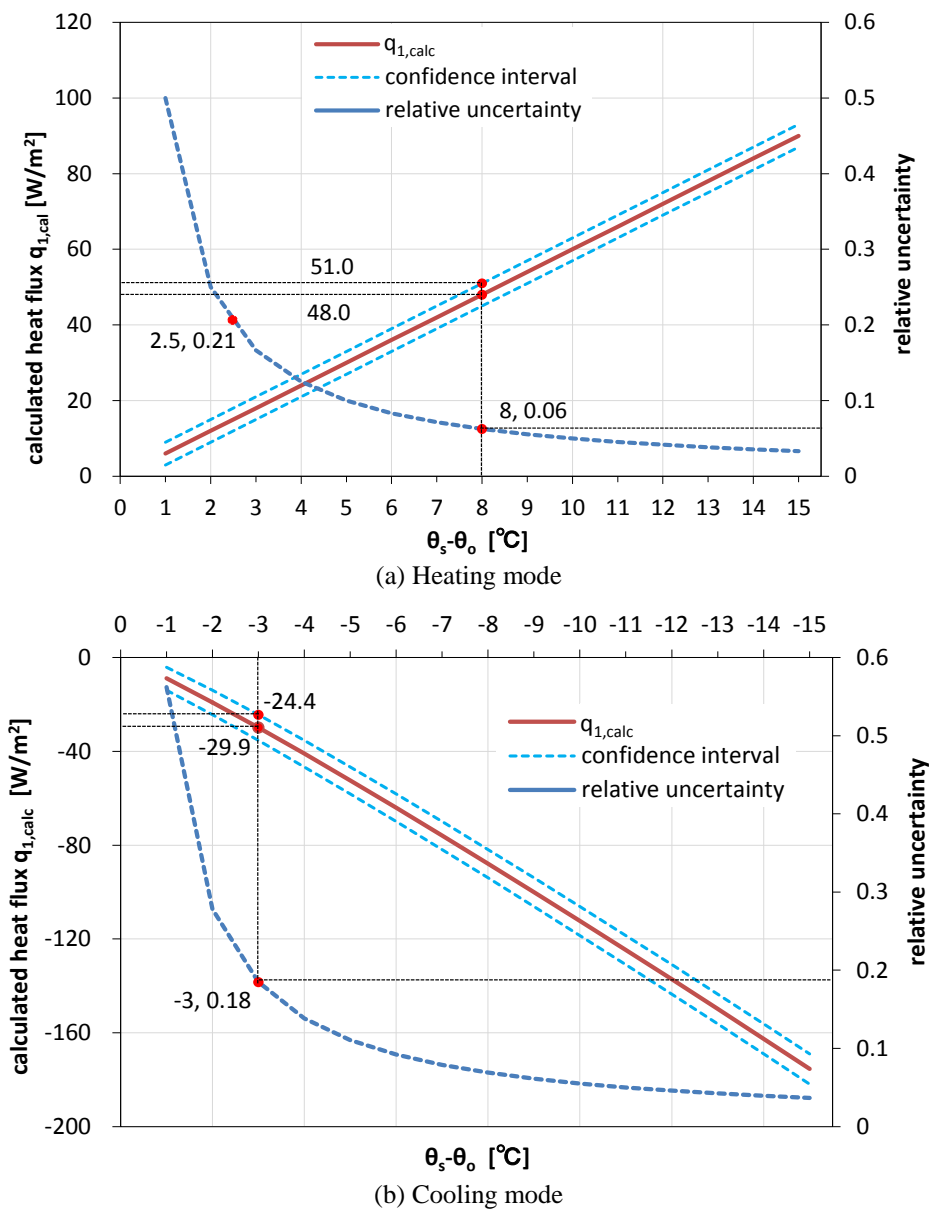

Figure 9 Relative uncertainty of calculated heat flux $q_{1,calc}$

Fig. 9 shows the relative uncertainty (ratio of uncertainty to $q_{1,calc}$) of the calculations. It is obvious that as the temperature difference $\theta_s - \theta_o$ decreases, the relative uncertainty of $q_{1,calc}$ increases. The red points in Figure 9 (a) show the relative uncertainty, where $\theta_s - \theta_o$ is 8°C and 2.5°C, respectively. The relative uncertainty at 8°C is $(51.0-48.0)/48.0 = 0.06$ and that at 2.5°C is 0.21. Figure 9 (b) shows that the relative uncertainty at -3°C for cooling cases is 0.18. Because the relative uncertainty increases when the absolute temperature difference decreases, the accuracy of $q_{1,calc}$ reduces from H1, H2, H4, C1–C3, to H3. This could explain the increase in the relative deviation.

This result indicates that ISO 11855-2 can also be applied to suspended ceiling systems; however, the accuracy is reduced when the temperature difference between the radiant surface and the room decreases. Thus, it is necessary to use very accurate sensors when the temperature difference is small.

(2) Heat flux and heat transfer coefficient

Table 5 lists the measurement results for the heat flux q_1 and overall heat transfer coefficient U_{wo} . In the testing room, the space above the ceiling is a plenum connected to an exhaust system. Therefore, the heat flux to the above space q_2 could be heat loss. The downward heat flux ratio of q_1/q_w can be considered an indicator of the heat use efficiency in the occupied room. Its value was 61–65% for H1, H2, and H4 and 65–72% for C1–C3. This result indicates that the heat flux in the upward direction is 30–40% with the exhaust system in operation; this could be considered heat loss.

For H3, with a supply water temperature of 28°C, the downward heat flux ratio increased to 83% and the upward heat flux reduced to 17%.

The overall heat transfer coefficient U_{wo} is ~ 3.7 W/(m²K) for H1, H2, and H4 and 4.2 W/(m²K) for H3. For cooling mode, U_{wo} is 4.7–4.9 W/(m²K), which is higher than in the heating cases.

Table 5 Measurement results for heat flux and heat transfer coefficient

	H1	H2	H3	H4	C1	C2	C3
$\theta_w - \theta_o$ [°C]	14.0	13.6	4.3	9.6	-7.2	-6.8	-5.7
q_w [W/m ²]	82.0	78.6	21.8	54.8	-51.0	-49.1	-38.8
q_1 [W/m ²]	49.8	50.80	18.2	35.0	-35.4	-32.0	-27.8
Downward heat flux ratio q_1/q_w	61%	65%	83%	64%	69.3%	65.2%	71.8%
U_{wo} [W/(m ² K)]	3.6	3.7	4.2	3.7	4.9	4.7	4.9

3.2 Thermal comfort

The desired thermal environment for the classroom is category B according to ISO 7730 (2005). Table 6 shows the limits of factors in category B.

Table 6 Factors of thermal environment Category B

PPD%	PMV	Vertical air temperature difference	Radiant asymmetry	PD% Caused by warm or cool floor	DR%
<10	-0.5 < PMV < +0.5	< 5	< 5	<10	< 20

(1) PD% and DR%

PD% is the percentage of people dissatisfied by the floor temperature which is estimated by a function given in ISO 7730. The floor temperature of the classroom was about 27°C and 24°C in cooling time and heating time, respectively. For these temperatures ISO 7730 gives a PD% that is less than 10%. DR% is the percentage of people predicted to be bothered by draught. An estimate relationship between air velocity and DR% is recommended in ISO 7730. Due to only radiant ceiling panel system was used during the measurements, the air velocity was weak. The indoor air velocity was less than 0.03 m/s which gives a DR% much lower than 20%.

(2) Indoor temperature distribution

Figure 10 shows the indoor temperature distributions for H2 and C3. The vertical air temperature difference between 0.1 m and 1.7 m is less than 1.5°C. The θ_o difference from the window side to the center of the room and to the internal corner is also less than 1.5°C. The air temperature and θ_o distributions in the room were highly uniform, which contributes toward a category B thermal environment.

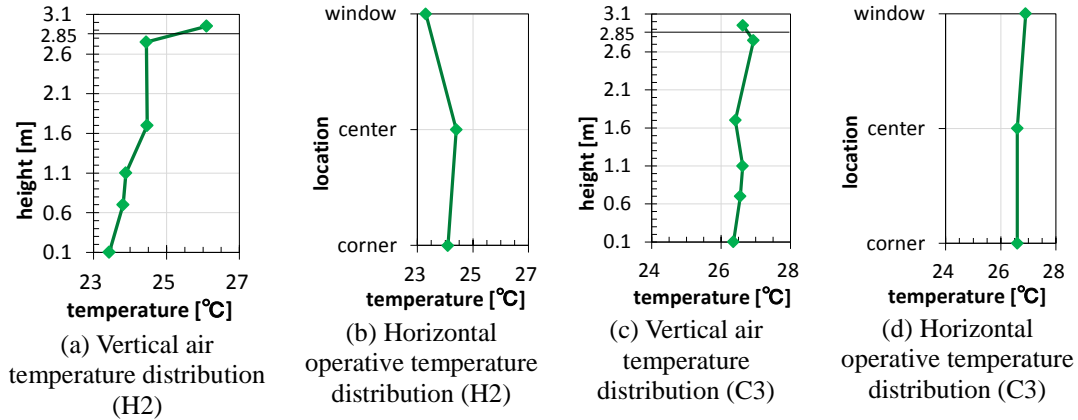

Figure 10 Indoor temperature distribution

(3) PMV and PPD

Figure 11 shows the PMV and PPD for H2 and C3. For the calculation Met was 1.1 and clo was 0.3 for summer and 1.0 for winter. In both heating and cooling, the PMV was higher than -0.5 and less than +0.5, the PPD was less than 10%.

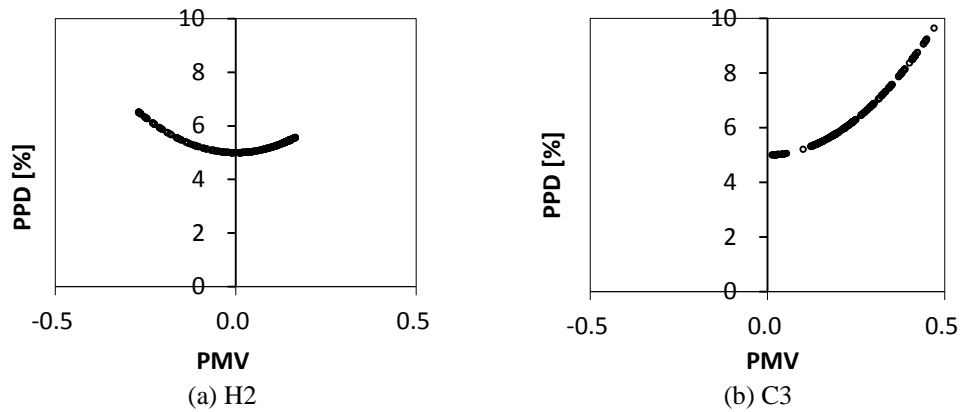

Figure 11 PMV and PPD

All the criteria are satisfied simultaneously and the category B thermal environment was obtained using the radiant ceiling heating/cooling system.

4. Discussion and conclusion

Good agreement was found between the theoretical heat flux and the measured data. The relative deviation is less than 4% for the heating mode and ~7% for the cooling mode. The deviations for the cooling cases are larger than those for the heating cases. This is because during the cooling measurements, the relative uncertainty of the measurement heat flux was much larger than in the heating mode. This indicates that ISO 11855-2 can be applied to suspended ceiling systems; however, its accuracy reduces as the temperature difference between the radiant surface and the room decreases. Thus, it is necessary to use very accurate sensors when the temperature difference is small.

The overall heat transfer coefficient U_{wo} was ~3.7 W/(m²K) and 4.8 W/(m²K) for heating mode and cooling mode, respectively. The downward heat flux ratio q_1/q_w was 61–65% for heating mode and 65–72% for cooling mode. This shows that the upward heat flux is approximately 30–40% while the exhaust system is operating; this could be considered heat loss. The upward heat flux was large, especially during heating cases. The insulation above the panels should be improved to reduce the upward heat loss. In addition, using the plenum as an air supply “duct” could also reduce the heat loss by bringing the heat into the room with the supply air.

With regard to heating cases, it was obvious that the performance of case H3 was different from that of other cases in light of the much lower water temperature (Tables 3 and 5). For H3, the upward heat flux, which is the potential heat loss, was 17%, which was half that in other cases. However, the heating capacity reduced dramatically to ~22 W/m². An optimal water temperature is assumed to exist with high heat use efficiency and sufficient heating capacity. Furthermore, because the heating loads vary with the weather, the water temperature should not be constant.

The air temperature difference between 0.1 m to 1.7 m was less than 1.5°C in both heating and cooling modes; furthermore, the θ_o distribution at 0.7 m level was no more than 1.5°C. The room temperature was highly uniform. In both heating and cooling, the PMV was higher than -0.5 and less than +0.5, the PPD was less than 10%. A category B thermal environment was obtained using the radiant ceiling heating/cooling system.

Acknowledgments

The authors would like to thank Tomonari Yashiro, Bumpei Magorio, Hiroshi Sako, et al., the collaborators of the reported experimental building. The authors acknowledge the funding agencies including NEDO for their support and contribution.

References

Kolarik J, Toftum J, Olesen BW, Jensen KL, 2011. Simulation of energy use, human thermal comfort and office work performance in buildings with moderately drifting operative temperatures. *Energy and Buildings*, 43:2988-2997.

Olesen BW, 2002. Radiant floor heating in theory and practice. *ASHRAE Journal*.

Okamoto S, Kitora H, Yamaguchi H, Oka T, 2010. A simplified calculation method for estimating heat flux from ceiling radiant panels. *Energy and Buildings*, 42:29-33.

Olesen BW, 2011. Radiant heating and cooling by embedded water-based systems. I Congreso Clima2011plus.

Ooka R, Yashiro T, et al. 2013, Zero Energy Building Project in the University of Tokyo. CLIMA 2013, Prague.

Causone F, Corngati SP, Filippi M, Olesen BW, 2009. Experimental evaluation of heat transfer coefficients between radiant ceiling and room. *Energy and Buildings*, 41:622-628.

Karadag R, 2009. The investigation of relation between radiative and convective heat transfer coefficients at the ceiling in a cooled ceiling room. *Energy Conversion and Management*, 50.

Zhang L, Liu X-H, Jiang Y, 2013. Experimental evaluation of a suspended metal ceiling radiant panel with inclined fins. *Energy and Buildings* 2013, 62:522-5299.

Jeong J-W, Mumma SA, 2003. Ceiling radiant cooling panel capacity enhanced by mixed convection in mechanically ventilated spaces. *Applied Thermal Engineering*, 23:2293-2306.

Diaz NF, Lebrun J, Andre P, 2010. Experimental study and modeling of cooling ceiling systems using steady-state analysis. *Refrigeration*, 33:793-805.

Fonseca N, 2011. Experimental study of thermal condition in a room with hydronic cooling radiant surface. *Refrigeration*, 34:686-695.

Jeong J-W, Mumma SA, 2004. Simplified cooling capacity estimation model for top insulated metal ceiling radiant cooling panels. *Applied Thermal Engineering* , 24:2055-2072.

ISO 11855-2. 2012. Building environment design — Design, dimensioning, installation and control of embedded radiant heating and cooling systems — Part 2: Determination of the design heating and cooling capacity. International Organization for Standard, Genève, Switzerland.

EN 14240. 2004. Ventilation for buildings — Chilled ceilings — Testing and rating. European Committee for Standardization, Brussels, Belgium.

ANSI/ASHRAE Standard 138-2009. 2009. Method of testing for rating ceiling panels for sensible heating and cooling. American Society of Heating, Refrigerating and Air-conditioning Engineers, Inc., Atlanta, USA

EN 14037-1. 2003. Ceiling mounted radiant panels supplied with water at temperature below 120°C. European Committee for Standardization, Brussels, Belgium.

Shida H, Ooka R, et al. 2012, ZEB-oriented Project in University Campus (part 5) Development and performance validation of simple double-skin configured by movable louver. The Summaries of Technical Papers of Annual Meeting 2012, Architectural Institute of Japan.

Simone A, Babiak J, Bullo M, Landkilde G, Olesen BW, 2007. Operative temperature control of radiant surface heating and cooling systems. Proceedings of Clima 2007 Wellbeing Indoors.

ISO 7726. 1998. Ergonomics of the thermal environment — Instruments for measuring physical quantities. International Organization for Standard, Genève, Switzerland.

JIS C1604-1997. Resistance thermometer sensors. Japanese Industrial Standards, Tokyo, Japan.

JCGM 100: 2008 GUM 1995 with minor corrections. 2008. Evaluation of measurement data — Guide to the expression of uncertainty in measurement.

ISO 7730. 2005. Ergonomics of the thermal environment — Analytical determination and interpretation of thermal comfort using calculation of the PMV and PPD indices and local thermal comfort criteria. International Organization for Standard, Genève, Switzerland.

Nomenclature

θ_s	mean surface temperature of the radiant panels [°C]
θ_u	mean temperature of the plenum space [°C]
θ_o	operative temperature measured in the middle of the room at 0.7 m above the floor [°C]
θ_w	mean heating/cooling water temperature [°C]
q_w	heating/cooling capacity of the water [W/m ²]
q_1	heat flux from the water to the room [W/m ²]
q_2	heat flux from the water to the plenum [W/m ²]
$q_{1,meas}$	measurement heat flux [W/m ²]
$q_{1,calc}$	calculated heat flux [W/m ²]
$\theta_{w,in}$	supply water temperature [°C]
$\theta_{w,out}$	return water temperature [°C]
m	water flow rate [m ³ /h]
ρ	water density [kg/m ³]
c	specific heat capacity of the water [kJ/(kgK)]
R_{ws}	thermal resistance between the fluid and the panel surface [m ² K/W]
R_{so}	thermal resistance from the panel surface to the room [m ² K/W]
R_{su}	thermal resistance from the panel surface to the plenum [m ² K/W]
R_{wo}	thermal resistance between the water and the room [m ² K/W]
R_{wu}	thermal resistances between the water and the plenum [m ² K/W]
U_{wo}	overall heat transfer coefficient from the water to the room [W/(m ² K)]
U_{wu}	overall heat transfer coefficient from the water to the plenum [W/(m ² K)]
U_{so}	heat transfer coefficient between the radiant surface and the room [W/(m ² K)]

The gap between what is said and what is done: a method for distinguishing reported and observed responses to cold thermal discomfort

Stephanie Gauthier¹ and David Shipworth¹

1 UCL Energy Institute, Central House, 14 Upper Woburn Place, London, UK.

Abstract

The need to identify occupants' behaviour-responses to thermal discomfort during the heating season has become one of the priorities in the quest to reduce energy demand. The current models have long been associated with people's behaviour by predicting their state of thermal comfort or rather discomfort. These assumed that occupants would act upon their level of discomfort through two-types of response set as involuntary mechanisms of thermoregulation, and behaviour-responses. Surprisingly, little research has focused on the behavioural aspect, and one of the key challenges is to gather accurate measurements while using 'discreet', sensor based, observatory methods in order to have minimum impact on people's behaviour. To address these issues, this paper introduces a mixed-methods approach that enabled the establishment of a three-tiered framework mapping behaviour-responses to cold sensations, consisting of (1) increasing clothing insulation level (I_{cl}), (2) increasing operative temperature by turning the heating system on/up, and (3) increasing the frequency, duration and/or amplitude of localised behaviour responses, including for example warm food or drink intake, changing position, changing location within the same room or changing room. Drawing from this framework, this paper introduces an extended model of thermal discomfort response that incorporates a wider range of observed behaviours.

Keywords: Occupant behaviour; thermal comfort; mixed-methods; ubiquitous sensor technologies.

1 Introduction

During the heating season, indoor temperature is one of the strongest determinants of energy used in buildings. As of 2011, the domestic sector was responsible for a large share of the total energy consumption in the UK, approximately 28% (DECC, 2012). Space heating alone accounted for 63% of the UK's household energy consumption in 2009 (DECC, 2013). Therefore strategies aiming to reduce domestic heating consumption can make a significant contribution towards the UK's national CO₂ emissions reduction commitments (CCC 2008). As a result, thermal comfort acceptability and practices play a key role in the quest to reduce energy use.

Using a mixed-method framework, this paper seeks to investigate the variability of reported and observed behaviour-responses in residential buildings during the heating season. A number of case study participants were chosen as the focus of the study; however it is believed that the methods could be transferable to all types of buildings.

Drawn from the current methods used to assess occupant's thermal comfort acceptability and from psychological research, this paper introduces a three-tiered methodological framework to identify occupants' responses to cold thermal discomfort. Results of semi-structured interviews revealed three broad categories of occupant behavioural response to cold thermal discomfort:

1. Increasing clothing insulation level.
2. Increasing operative temperature by turning the heating system on/up.
3. Increasing the frequency, duration and/or amplitude of localised behaviour responses, including:
 - a. Consuming warm food and/or liquid.
 - b. Changing body position, location within the same room, or room within the dwelling.
 - c. Opening and closing of curtains and/or windows.
 - d. Using a local device: hot-water bottle, having a warm bath, etc.

These categories are then used as an analytical frame for the analysis of automated visual diaries. Surprisingly, the results from the analysis of the semi-structured interviews, and the automated visual diaries, revealed major differences between what occupants self-reported, and what occupants were observed to do, in response to cold thermal discomfort. To complement this finding, clothing thermal insulation levels were monitored using wearable sensors, and compared to living room temperature levels. The mixed methods employed, and the findings of this study, enable the introduction an extended model of thermal discomfort responses that incorporates a wider range of observed behaviours.

2 Methods

Current thermal comfort field studies often involve modelling and analysis at the household level (Oseland, 1994, Crosbie 2006, Hong et al. 2009). Usually, these studies are using mixed methods approaches, which include standard comfort questionnaires, and monitoring of environmental parameters. Their focus is to investigate the relationships between social or technical factors, and participants' thermal comfort level or dwellings' indoor temperatures. Surprisingly, occupant's actual responses to thermal discomfort are not reviewed. Moreover cross-sectional studies and 'static' heat balance models are used to report on a dynamic system. To address these two issues, the research presented in this paper draws methods from psychological and physiological research to monitor people and their environment through continuous periods of time.

The sampling frame was defined by the 3-physiological attributes prescribed by ISO 8996: 2004 Annex C, as gender, age and weight. The sample frame was populated across combinations of categories using a mixture of convenience and snowball sampling with, 20 participants living in 19-different dwellings. The study was carried out in the South-East of England, during the winters of 2012 and 2013, monitored external temperatures were below the degree-day threshold of 15.5°C for 99.8% of the recording period, and low enough to require space heating (CIBSE, TM41, 2006). Each participant was monitored over a period of 10-consecutive days; concurrently environmental variables were recorded, and semi-structured interviews conducted at the end of each monitoring period; see Figure 1.

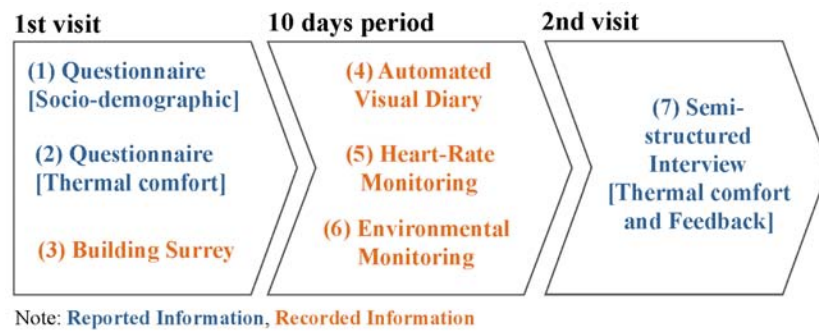

Figure 1. Individual case study data collection sequencing.

Environmental monitoring took place throughout the 10-days. Three sets of 4-dataloggers were placed in the home in living rooms and in bedrooms to record ambient air temperature (T_a) and relative humidity (RH). These devices were programmed to start 30-minutes before the first interview, and recorded a reading every 5-minutes. The 4-dataloggers were fastened to wooden-pole and positioned at 0.1m, 0.6m, 1.1m and 1.7m from the ground to comply with the requirements set by ISO 7726:2001.

Concurrently, an automated visual diary was recorded using a SenseCam (Vicon Motion Systems, Microsoft, UK). This wearable recording device took photographs manually when triggered by the user, and automatically when triggered by a timer or by changes in sensors' readings. It incorporates a temperature sensor, a light intensity and light-colour sensor, a passive infrared detector, a tri-axis accelerometer, and a magnetometer (Gauthier and Shipworth, 2013). In total 146,284 images were generated for the 20-participants, which represents an average of 7,314 pictures for each participants. These pictures enabled participants' whereabouts to be mapped, and in particular their food and drink intake, their activity, and thermal insulation levels to be identified. In addition to the SenseCam, a chest strap and logger was handed out. This compact device recorded heart rate, which was used to evaluate the participants' activity level.

Ten days after the first visit, the researcher returned to the dwelling to collect the equipment, and to conduct a semi-structured interview with the participant. The aim of this interview was to gather feedback on the monitoring methods employed, and reported information on thermal discomfort responses. Open-ended questions addressing typical responses to thermal discomfort, associated thresholds, and influencing factors, enabling insight to be gained into the participant's relationship with their home's thermal comfort system. Content analysis was used to analyse interview transcripts in order to gain an understanding of the participants' responses to thermal discomfort and associated influencing factors.

In summary, this mixed-method framework was established in order to map a rich picture over a continuous timeframe of people's variability in daily activity in order to capture and categorise participants' behaviour-responses to thermal discomfort.

3 Results

The results of the semi-structured interviews, the visual diary, and of the monitoring were analysed separately, and then compared and contrasted. Surprisingly there is large variation between what occupants say and what occupants do with respect to their thermal discomfort responses.

3.1 Reported responses to thermal discomfort

Using content analysis, the semi-structured interviews were partially transcribed focusing on the three discussions guide themes: ‘typical responses’, ‘thresholds’ and ‘influencing factors’ to thermal discomfort. The results of this analysis summarised in Figure 2 reveal that the most frequently reported responses to thermal discomfort for the sample group were:

- Layering through putting on clothes and increasing their thermal insulation (47%).
- Interacting with the home heating system, using TRVs, room thermostat, or programmers (24%).

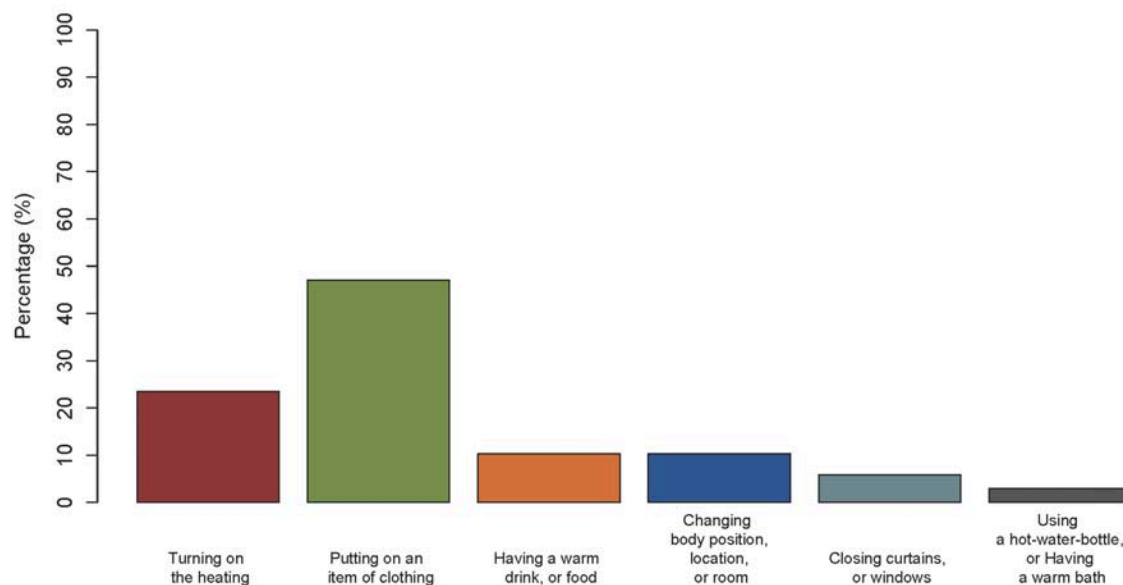

Figure 2. Semi-structured interview results - Reported responses to thermal discomfort.

Interestingly, the influencing factors to thermal discomfort are varied and responses suggest that a dwelling comfort system may not be restricted to the mechanical system but include ‘friend and family’, ‘neighbours’ and ‘household characteristics’.

3.2 Observed responses to thermal discomfort

Through the diary collection, the SenseCam device captured automatically up to 24,306 images, and an average 7,314 images per participant over a monitoring period of 10-days or more. This yields to a very large collection of images. To process this information, automatic segmentation was used in a 5-steps sequence:

- Formatting - After uploading the SenseCam data, the images and the output from the temperature sensor were extracted from the diary-log. This temperature entry gives an estimation of the temperature at the surface of the clothing on the participants' chests, and is refer to as T_{clo} expressed in degree Celsius ($^{\circ}C$).

- Formatting - T_{clo} readings were then averaged over the chosen time-unit of analysis set as a 1-minute epoch.
- Normalising – While reviewing T_{clo} time-series profiles, temperature rises were observed each time a participant put-on the SenseCam. These artefacts are unwanted information contained within T_{clo} reading profiles. Prior to carrying-out the analysis, the profiles were reviewed, and these artefacts discounted; this process is called normalising. The method consists in identifying the temperature rise-time due to the resistance of the device and/or to changes in the environment. To do so, a software filter was written which identify the lagged differences between consecutive readings. The filter boundary condition was set to T_{clo} being stable during a 5-minutes period.
- Structured-query - Consecutive normalised T_{clo} readings were compared, and if those increased or decreased by 1°C or more, associated images were identified.

This structured data-query process enabled filtering of the images to those in close proximity to observed changes in T_{clo} making manual inspection of the remaining images possible. Inspection of the images then allowed for identification of the reasons for changes in T_{clo} .

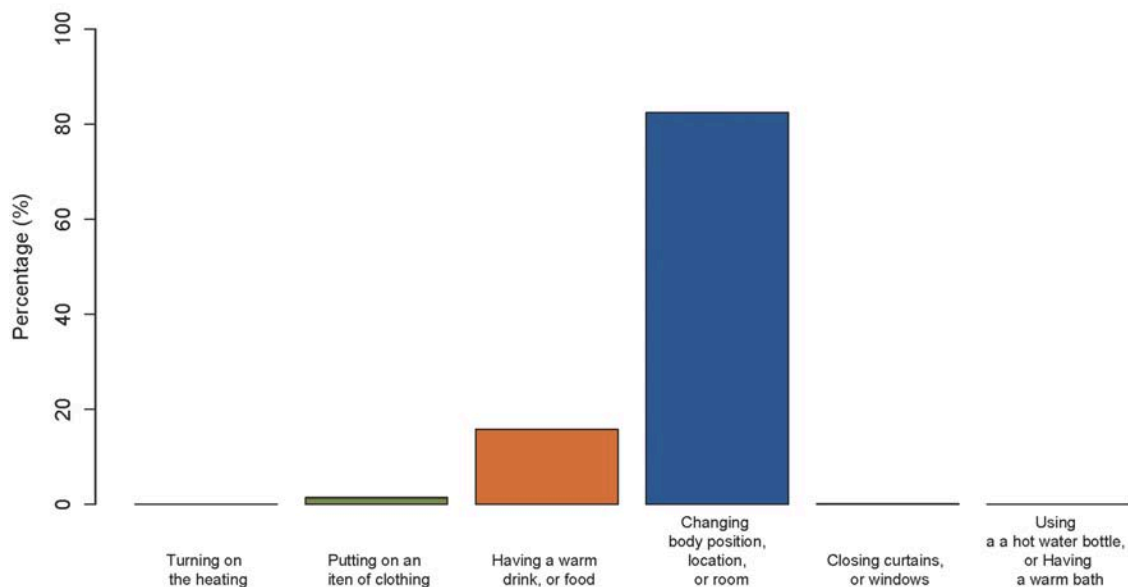

Figure 3. Automated diary results - Observed responses to thermal discomfort.

Through this approach participants responses to changes in T_{clo} were identified, and the results are summarised in Figure 3. Interestingly, the frequencies of observed responses differ greatly to the reported responses. It is important to note that the localised behaviour responses observed in the SenseCam images are not necessarily thermal discomfort responses; they may arise for a range of other reasons. To explore this issue, regression analysis between indoor monitored temperature (T_a) and the most frequently reported response (clothing insulation levels) and the most frequently observed response (motion), are carried out in the next section.

3.3 Predicted responses to thermal discomfort

Predicted responses are drawn from the framework of the predictive indices. Developed from laboratory experiments in climate chambers, this framework combines knowledge of the

human body physiology and of the heat-transfer theories in which 6-variables are accounted for (ISO 7730:2005), including:

- 4-environmental variables: ambient air temperature (T_a), mean radiant temperature (T_r), relative humidity (RH) and air velocity (v_a).
- 2-personal variables: thermal insulation of clothing (I_{cl}) and metabolic rate (M).

Focusing on thermal insulation of clothing (I_{cl}), this personal variable was estimated as continuous, objective and quantitative using ASHRAE 55:2013, Appendix B, ‘First guess for surface temperature of clothing’, where:

$$T_{cloa} = T_{aa} + [(35.5 + T_a) \div (3.5 \times (6.45 \times I_{cl} + 0.1))] \quad (1)$$

$$I_{cl} = [((35.5 - T_a) \div (T_{cloa} - T_{aa})) \div 3.5 - 0.1] \div 6.45 \quad (2)$$

where T_{cloa} is the surface temperature of clothing in Kelvin, T_{aa} is ambient air temperature in Kelvin, T_a is ambient air temperature in Celsius, and I_{cl} is thermal insulation of clothing in m^2K/W .

To resolve this equation, T_a and T_{clo} are estimated as follow. Ambient air temperature (T_a) was measured using HOBO U12-012 dataloggers. Three set of 4-dataloggers were placed in living-rooms and in bedrooms, fastened to wooden-poles and positioned at $0.1m$, $0.6m$, $1.1m$ and $1.7m$ from the ground to comply with the requirements set by ISO 7726:2001. For the purpose of the analysis, T_a accounts for the temperature monitored in living room while standing or the mean temperature over 3-heights - $0.1m$, $0.6m$ and $1.7m$. As the monitoring frequency was set at 5-minutes, a step-function was applied to generate a 1-minute sampling rate.

Relative air velocity (v_a) was measured during the first visit. For all participants, the results were equal to or below $0.1m/s$. Therefore a relative air velocity of $0.1m/s$ was assumed for all cases on a basis that in winter openings tend to stay close (Hong et al., 2009). As relative air velocity was equal to or below $0.1m/s$, the surface temperature of clothing (T_{clo}) may be estimated using the SenseCam temperature recordings. The data processing was similar to the observed-responses segmentation method. First, readings were averaged over the chosen time-unit of analysis set as 1-minute. Then a normalising process was carried out to identify and discount four artefacts, including:

- Temperature rise-time as a function of the observed resistance temperature of the SenseCam when switched-on and worn.
- Participants in motion.
- SenseCam been taken-off but left switched on.
- SenseCam been worn under an item of clothing.

As the monitoring was carried-out on the chest, only the upper-body thermal insulation level was estimated; therefore a constant value of $0.3 clo$ or $0.0465 m^2K/W$, as the aggregation of lower-body garments, including underwear, trouser or skirt and socks, was added to the final I_{cl} value (ISO 9920: 2007). The final sample size amounts to 18,559 data-points. The estimated range of 0.43 to $1.99 clo$ is within the expected standard values as described in ISO 9920: 2007. However the estimated mean value of $0.82 clo$ is lower than the usually assumed winter value of $1 clo$ given as constant in building energy simulation (Schiavon and Lee, 2013).

Having estimated thermal insulation of clothing (I_{cl}) as a quantitative, objective, and continuous variable, its relationship with ambient temperature (T_a) may be evaluated using regression analysis. If participants were to always adjust their thermal insulation level by adding more clothing items as a response to colder temperatures, then the correlation coefficient should be close to -1 . However the results show a very weak relationship between measured indoor air temperature and estimated clothing insulation ($R=0.0134$), which is in agreement with the observed response to thermal discomfort described in section 3.2. However this result might be due to the analysis design as all participants were grouped in one sample. Further analysis of the data on a participant-by-participant basis revealed within-subject variations. Figure 4 shows that one half of the participants slightly increases clothing level as indoor air temperature decreases; however the other half of the participants decrease their clothing level as indoor air temperature decreases.

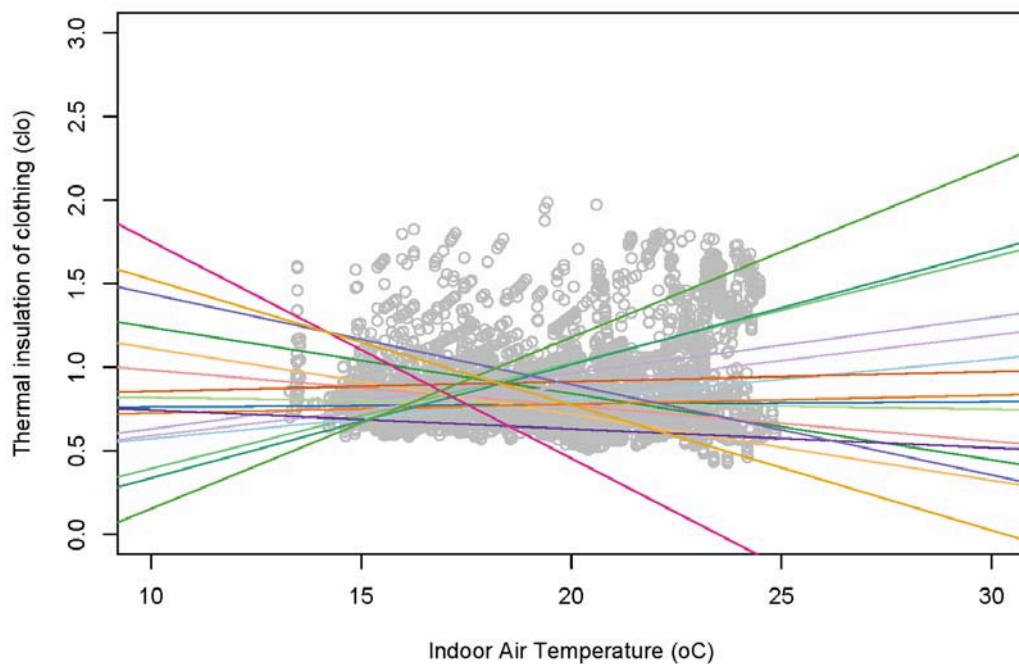

Figure 4. Monitored results – Regression analysis between monitored ambient air temperature and estimated thermal insulation of clothing for all participants with the fitted linear regression lines for each participants.

These findings establish that there is a gap between participants self-reported and sensor-observed use of clothing as a response to cold thermal discomfort. While participants reported putting on clothes when they were cold – this was not observed for half of the participants. Therefore this suggests that other behaviour-responses may be being employed, such as turning-on/up the heating or localised behaviour responses.

Following this analysis, the most frequently observed response - participants' activity level (motion) was estimate from the output of the SenseCam tri-axis piezoresistive accelerometer. Participants' total acceleration (TA) was calculated as the normalized magnitude of the acceleration vector including the earth's gravity (Shala and Rodriguez, 2011):

$$TA = \sqrt{(x^2 + y^2 + z^2)} = \text{Linear Acceleration} + g \quad (3)$$

where TA is the total acceleration in m/s^2 , x is acceleration in the x-axis in m/s^2 , y is acceleration in the y-axis in m/s^2 , z is acceleration in the z-axis in m/s^2 , and g is the earth's gravity of $9.81 m/s^2$.

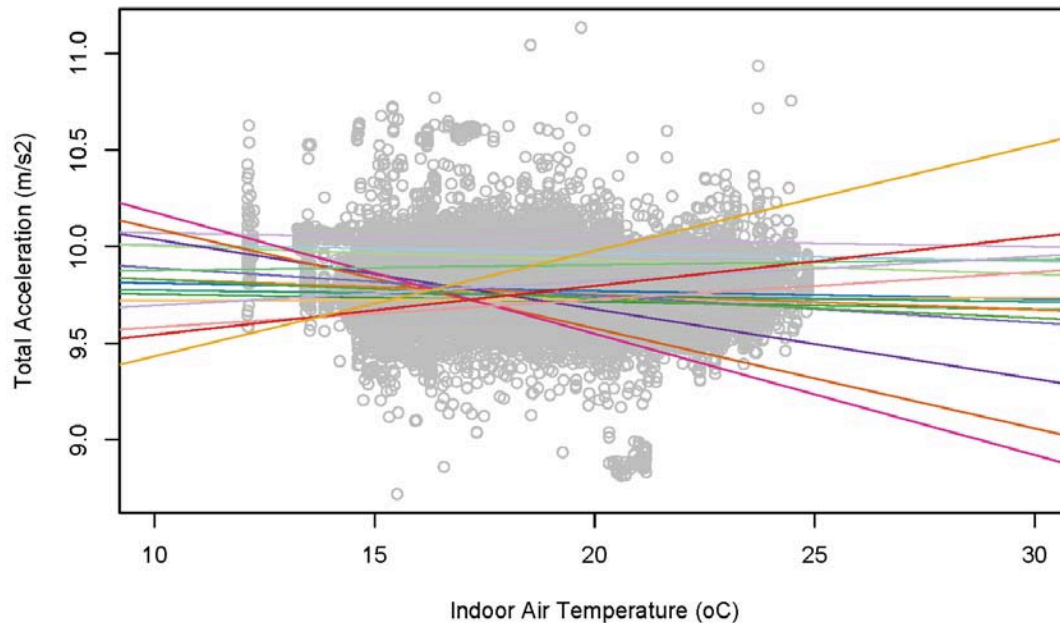

Figure 5. Monitored results – Regression analysis between monitored ambient air temperature and estimated total acceleration for all participants with the fitted linear regression lines for each participants.

The estimated total acceleration (LA) was then compared to the measured ambient air temperature (T_a) for each participant, see Figure 5. The overall sample size amounts to 31,540 data-points. The results show that most participants tend to be slightly more active as ambient temperature gets colder. Only 4-participants were less active in colder temperature; this is may be due to the fact that these 4-participants lived in relatively warmer environments and did not experience temperature below 19°C. These findings establish that there is some agreement between participant diary-observed and sensor-observed motion level as a response to cold thermal discomfort. As participants feel colder, they may chose to adjust their position, their location within the room, or to change room; this form part of the localised behaviour responses.

4 Thermal response model

This paper compares and contrasts occupant-self-reported and observed responses to thermal discomfort and finds a marked difference between them. Most participants reported that if feeling cold they would put on an item of clothing. In contrast, observed responses identified through the automated visual diary are very different, as participant increased clothing only in 1.4% of the observations made. This observed result is confirmed by the very weak relationship between measured air temperature (T_a) and estimated clothing insulation (I_{cl}), which was estimated from measured temperature at the surface of the clothing on participants' chests (T_{clo}) and measured air temperature (T_a). These findings establish that there is a gap between [reported] and [observed & monitored] responses in the use of clothing as a response to cold thermal discomfort. This suggests that other behaviour-responses may be employed by the occupants, including turning-on/up the heating and localised behaviour responses.

From this interpretation, one might consider the heat flow around the body as a simple one-dimensional system (see Figure 6); where the temperature at the surface of the clothing is function of skin temperature (T_{sk}), ambient temperature (T_a), temperature derived from localised behaviour (T_{bev}) and the resistances in between.

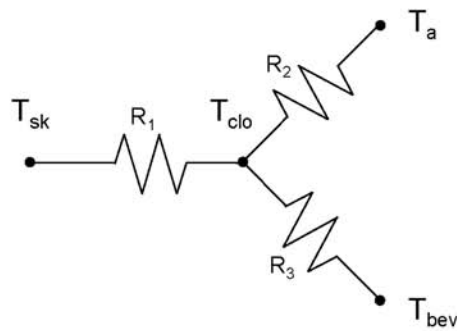

Figure 6. Diagram of heat flow around a human body – *Thermal Response Model (TRM)*.

The reduction of the inputs and associated resistances to a single node may be represented as an application of the Millman's Theorem, where:

$$T_{clo} = \frac{\frac{T_{sk} + T_a + T_{bev}}{\frac{1}{R_1} + \frac{1}{R_2} + \frac{1}{R_3}}}{\frac{1}{R_1} + \frac{1}{R_2} + \frac{1}{R_3}} \quad (4)$$

Findings from this study suggest that all three resistances in the model, including R_1 , the resistance of clothing, remain largely constant. This leaves variation of T_a (through controlling heating systems) and variation of T_{bev} (through a range of local behavioural responses) as the observed mechanisms for cold thermal discomfort alleviation.

In practice, further studies could explore different practical scenarios, including:

- Localised action – if all input variables stay constant but T_a decreases, one response could be to ‘have a warm drink’ then T_{bev} increases and T_{clo} increases as a proportion of T_{bev} and R_3 .
- Heating – if all input variables stay constant but T_a decreases, one response could be to ‘put the heating on’ then T_a increases and T_{clo} increases as a proportion of T_a and R_2 .
- Changing room – if all input variables stay constant but T_a decreases, one response could be to ‘move to a warmer room’ then T_a increases and T_{clo} increases as a proportion of T_a and R_2 .

5 Conclusions

This paper compares and contrasts occupant-self-reported and observed responses to thermal discomfort and finds a marked difference between them. This led to the development of a *thermal response model* as a simple one-dimensional system in which the skin surface temperature is assumed to be constant. Future work should include heat flow within the human body.

Theoretically, this paper introduces an extended model of discomfort response that incorporates a wider range of observed behaviours. Methodologically, this paper demonstrates the efficacy of multi-method observational approaches for understanding discomfort responses. Substantively, this paper highlights the need for researchers working in this field not to fall into the gap between what occupants say and what occupants do.

Acknowledgement

The authors would like to thank the reviewers and to acknowledge UK EPSRC support for the London-Loughborough Centre for Doctoral Research in Energy Demand, grant number EP/H009612/1.

References

- ASHRAE. 2013. Standard 55-2013 - Thermal Environmental Conditions for Human Occupancy (ANSI approved), American Society of Heating, Refrigerating and Air Conditioning Engineers, Atlanta, GA.
- The Chartered Institute of Building Services Engineers (CIBSE), 2006. Degree days: theory and application, TM41, London, UK.
- Climate Change Act 2008 (c.27), London, UK.
- Crosbie, T., 2006. Household energy studies: The gap between theory and method. *Energy and Environment* 17(5): 735-753.
- DECC, 2012. Digest of United Kingdom energy statistics, Energy consumption by final user - energy supplied basis, 1970 to 2011 (DUKES 1.1.5). Technical report, Department of Energy and Climate Change. UK.
- DECC, 2013. Housing Energy Fact File 2012, energy use in homes. Technical report, Department of Energy and Climate Change. UK.
- Gauthier, S., and Shipworth, D. 2013. Review of Methods to Map People's Daily Activity – Application for Smart Homes. In A. Hakansson et al., eds. *Sustainability in Energy and Buildings SE* - 38. Springer Berlin Heidelberg, pp. 401-411.
- Hong, S. H., Gilbertson, J., Oreszczyn, T., Green, G. & Ridley, I., 2009. A field study of thermal comfort in low-income dwellings in England before and after energy efficient refurbishment. *Building and Environment*, 44, 1228-1236.
- ISO 2001. Ergonomics of the thermal environment - Instruments for measuring physical quantities. BS EN ISO 7726:2001.
- ISO 2005. Ergonomics of the thermal environment - Analytical determination and interpretation of thermal comfort using calculation of the PMV and PPD indices and local thermal comfort criteria. BS EN ISO 7730:2005.
- ISO 2004. Ergonomics of the thermal environment - Determination of metabolic rate. BS EN ISO 8996:2004.
- ISO 2009. Ergonomics of the thermal environment - Estimation of thermal insulation and water vapour resistance of a clothing ensemble (ISO 9920: 2007, Corrected version 2008-11-01). BS EN ISO 9920:2009.
- Oseland, N., 1994. A comparison of the predicted and reported thermal sensation vote in homes during winter and summer. *Energy and Buildings*, 21, 45-54.

Shala, U., and Rodriguez, A. 2011. Indoor positioning using sensor-fusion in Android devices (Student paper). School of Health and Society, Department Computer Science, Kristianstad University. Kristianstad, Sweden.

Schiavon, S., and Lee, K.H. 2013. Influence Of Three Dynamic Predictive Clothing Insulation Models On Building Energy Use, HVAC Sizing And Thermal Comfort. UC Berkeley: Center for the Built Environment.

Proceedings of 8th Windsor Conference: *Counting the Cost of Comfort in a changing world* Cumberland Lodge, Windsor, UK, 10-13 April 2014. London: Network for Comfort and Energy Use in Buildings, <http://nceub.org.uk>

Using building performance simulation to save residential space heating energy: A pilot testing

Shen Wei¹, Xiaoxin Wang², Rory Jones¹ and Pieter de Wilde¹

1 Building Performance Analysis Group, Plymouth University, Plymouth, UK, shen.wei@plymouth.ac.uk.

2 DesignBuilder Software Limited, Stroud, Gloucestershire, UK.

Abstract

This paper describes a pilot study testing the applicability of using building performance simulation (BPS) to quantify the impact of 28 energy saving behaviour changes on the residential space heating demand, based on a mid-terraced house located in the southwest of England.

The 28 behaviour change options were collected based on a combination of literature review and expert knowledge. DesignBuilder V3.2, whose thermal dynamic simulation engine is Energyplus 7.2, was used to predict the impact of each behaviour change option on the space heating demand of the case study house. The study shows that the predicted energy saving potentials of all 28 options are consistent with general expectations, and so BPS can be used to quantify the impact of energy saving behaviour changes. However, using this methodology in real applications to help occupants save energy still needs more efforts.

Keywords: Building performance simulation, Occupant behaviour, Residential building, Behaviour change, Energy saving

1 Introduction

In the UK, residential buildings are responsible for a significant part of the nation's greenhouse gas emissions (DEFRA, 2006). Therefore, reducing their energy consumption is essential for achieving the UK government's 2050 target for CO₂ emission reduction. In residential buildings, occupants can have a significant influence on the actual building energy consumption, caused by their operation of the building or the building systems (Morley and Hazas, 2011, Guerra-Santin and Itard, 2010, Haas et al., 1998).

In the past several decades, better understanding occupant behaviour in buildings has been the aim of numerous researchers (Wei et al., 2014, Fabi et al., 2012, Roetzel et al., 2010). To enhance building energy efficiency, building performance simulation (BPS) has been adopted as a useful tool in some studies to predict the impact of changing behaviour on building energy consumption (de Wilde et al., 2013, Kim and Altan, 2013, Love, 2012, Shorrock and Dunster, 1997), by comparing the energy consumption before and after the behaviour change. In these studies, however, researchers typically only explore a limited set of behaviour change options: de Wilde et al.(2013) carried out an initial study exploring the impact of changing door and curtain operations; Kim and Altan (2013) focused on the change of heating operation,

heating system and building external insulation; Love (2012) was interested in heating operation and building efficiency; Shorrock and Dunster (1997) used a physically-based model, BREHOMES, to predict the energy saving potential by improving the building construction and systems. However, occupants' behaviours that will affect building energy consumption have a much wider range than the ones that have been studied thus far (Gunay et al., 2013). Therefore, this paper first establishes a comprehensive classification of possible behaviour change options that can be applied in a UK residential building to reduce the building space heating demand, based on a combination of literature review and expert knowledge. Then the applicability of using building performance simulation to quantify the impact of these options on residential space heating consumption is examined. Some challenges of using building performance simulation to help real building occupants make behaviour change decisions are discussed in the paper as well.

The study introduced in this paper was carried out in the context of a currently running UK research project, eViz (Energy Visualisation for Carbon Reduction), which aims to change occupant behaviour in buildings through visualisations. In eViz, the usefulness of using BPS as a tool to help occupants reduce their energy demand is being explored, and this paper introduces some preliminary results of it.

2 Classification of behaviour change options

In general occupant behaviour relating to save building energy consumption can be classified into two classes, either curtailment or investment behaviour (Gardner and Stern, 2002). The curtailment behaviours refer to “using equipment or systems less frequently or intensively” (Gardner and Stern, 2008), so it is related to changing occupants' operation or control of the building or the building systems. The investment behaviours include “adopting more energy-efficient equipment or installing or maintaining efficiency-boosting modifications to existing energy equipment” (Gardner and Stern, 2008), and so it is about upgrading/retrofitting the building construction or the building systems. For both change classes, there would be a number of behaviour change options that can help to reduce residential space heating demand.

To provide a comprehensive list of behaviour change options, the method used here is based on a combination of literature review and expert knowledge. The reviewed papers were collected from (1) SCI impact journals, such as *Energy and Buildings*, *Building and Environment*, (2) key conferences, such as the IBPSA building simulation conference, and (3) government's official reports, using key words such as ‘energy efficient’, ‘behaviour change’, ‘intervention’ and ‘building retrofit’. The expert knowledge gathering was carried out among built environment professionals in the environmental building group of Plymouth University. From the literature review and the expert knowledge, available behaviour change options within a UK house are collect and listed in Tables 1 and 2, for investment and curtailment behaviours respectively.

Table 1. Options of investment behaviour.

Behaviour items	Options of investment behaviour
Upgrading façade insulation	(1) Adding external wall insulation; (2) Adding ground floor insulation; (3) Adding ceiling insulation; (4) Adding roof insulation.
Improving building air tightness	(1) Adding membranes; (2) Adding weather-stripe/draft excluders for windows/doors.
Upgrading external windows	(1) Adding window layers; (2) Changing filling materials.
Upgrading external doors	(1) Adding door layers; (2) Improving door insulation.
Upgrading the heating system	(1) Installing energy-efficient heating systems; (2) Installing smart control strategies for the heating system.
Upgrading curtains/blinds	(1) Fitting heavier blinds/curtains.

Table 2. Options of curtailment behaviour.

Behaviour items	Options of curtailment behaviour
Window operation behaviour	(1) Reducing window opening time when at home but not sleeping; (2) Closing all windows when leaving home; (3) Closing all windows before sleeping at night; (4) Closing all windows in unused rooms.
Door operation behaviour	(1) Reducing back door opening time when at home but not sleeping; (2) Closing the back door when the adjacent room is not used.
Blind/curtain operation behaviour	(1) Shutting off all blinds/curtains during night-time; (2) Opening the south-facing blinds/curtains when it is sunny outside.
Thermostat operation behaviour	(1) Lowering the thermostat settings; (2) Turning down thermostat settings when leaving home; (3) Turning down thermostat settings before sleeping at night.
TRV operation	(1) Setting different temperatures for different rooms; (2) Lowering the TRV settings; (3) Turning down the TRV settings when leaving homes; (4) Turning down the TRV settings before sleeping at night.
Boiler operation	(1) Turn off boiler when leaving homes.

3 Methodology

The building simulation model was developed in DesignBuilder V3.2, by which dynamic thermal simulations were performed hourly to predict the building energy performance during the winter period. DesignBuilder is the first comprehensive user interface of EnergyPlus (DesignBuilder, 2014), and DesignBuilder V3.2 adopts EnergyPlus 7.2 as the engine for dynamic thermal simulations. The energy saving potential of each behaviour change option was calculated as the difference between the energy consumption before the behaviour change and that after the change. The model was established according to a typical UK mid-terraced house located in an urban area in the Southwest of England (Figure 1a). The house is over 100 years old so its energy condition needs to be improved (the current Energy Efficiency Rating (EER) is D). The house has two floors and the front faces north. On the ground floor, there is a living room and kitchen, and on the first floor there are two bedrooms and a bathroom. There is a back door in the kitchen, linking the house and the garden. Figure 1b shows the simulation model of the case study house. For each casement window in the house, there is an outward opening top light, and the remaining part is fixed. The approximate opening area of the window is about 10% of the total area of the window.



(a) Case study home

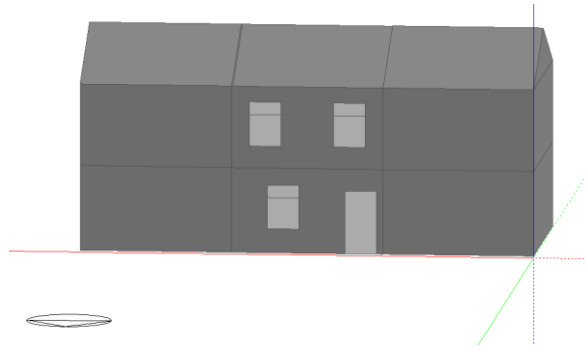

(b) Simulation model

Figure 1. Case study house.

The weather data used in the simulation was collected in 2002, from the main campus of Plymouth University, which is about 1 mile away from the case study house. The simulation period was from 1st October to 31st March. Simulation scenarios, before (base case scenario) and after behaviour change, are concluded in Tables 3 and 4, for investment and curtailment behaviours respectively, according to the behaviour change options defined in Tables 1 and 2.

Table 3. Simulation scenarios for investment behaviour.

Behaviour items	Base case scenario		Behaviour change option	After change scenario
Upgrading façade insulation	U-value = 2.071 (no insulation)	1	Adding external wall insulation	U-value = 0.260
	U-value = 1.463 (no insulation)	2	Adding ground floor insulation	U-value = 0.220
	U-value = 0.388 (75mm insulation)	3	Adding ceiling insulation	U-value = 0.250
	U-value = 2.930 (no insulation)	4	Adding roof insulation	U-value = 0.187
Improving building air tightness	Poor air tightness defined in DesignBuilder ¹	5	Adding membranes or Adding weather-stripe/draft excluder for windows/doors	Good air tightness defined in DesignBuilder
Upgrading external windows	Double clear glazing (3mm) filled with air (6mm)	6	Adding window layers	Triple clear glazing (3mm) filled with air (6mm)
		7	Changing filling materials	Double clear glazing (3mm) filled with argon (6mm)
Upgrading external doors	U-value = 2.251	8	Adding door layers	Adding an unheated porch at the entrance of the house
		9	Improving door insulation	U-value = 0.755
Upgrading the heating system	Efficiency = 60%	10	Installing energy-efficient heating systems	Efficiency = 80%
		11	Installing smart control strategies for the heating system	Lowering thermostat setting automatically to 18°C when the house is unoccupied.
Upgrading curtains/blinds	Drapes open wave (light)	12	Fitting heavier blinds/curtains	Drapes open wave (Medium)

¹ In DesignBuilder, the air tightness level is defined as five levels: excellent, good, medium, poor and very poor. Each air tightness level is defined by a combination of air leakage from Openings (windows, doors, vents), Walls, Floors/ceilings and Roofs.

Table 4. Simulation scenarios for curtailment behaviour.

Behaviour items	Base case scenario		Behaviour change option	After change
Window operation behaviour	All windows are open from 00:00 to 24:00	1	Reducing window opening time when at home but not sleeping	Closed when the house is occupied but not sleeping
		2	Closing all windows when leaving homes	Weekdays: closed between 08:00 and 18:00 Weekends: no change
		3	Closing all windows before sleeping at night	Mon to Thur: closed between 23:00 and 07:00+1 Fri and Sat: closed between 23:00 and 08:00+1
		4	Closing all windows in unused rooms	Only leave windows open when the room is occupied
Door operation behaviour	The back door is open when the house is occupied but not sleeping time	5	Reducing back door opening time when at home but not sleeping	Closed when the house is occupied but not sleeping
		6	Closing the back door when the adjacent room (kitchen) is not used	Only open when the kitchen is occupied
Blind/curtain operation behaviour	For weekdays: shut off between 07:00 and 18:00 & open for the rest	7	Shutting off all blinds/curtains during the night-time	Shut off always
	For weekends: shut off between 08:00 and 18:00 & open for the rest	8	Opening the south-facing blinds/curtains during the daytime to gain more solar energy	South-facing blinds/curtains always open
Thermostat operation behaviour	22°C always	9	Lowering the thermostat settings	20°C always
		10	Turning down thermostat settings when leaving homes	18°C when the house is not occupied
		11	Turning down thermostat settings before sleeping at night	Sleeping time: 18°C Unsleeping time: 22°C
TRV operation	all rooms set at 22°C always	12	Setting different temperatures for different rooms	Living room: 22°C Bedroom: 18°C Kitchen: 18°C Bathroom: 21°C Corridor: 18°C
		13	Lowering the TRV settings	all rooms set at 20°C always
		14	Turning down the TRV settings when leaving homes	Occupied time: 22°C Unoccupied time: 18°C
		15	Turning down the TRV settings before sleeping at night	Sleeping time: 18°C Unsleeping time: 22°C
Boiler operation	boiler always on	16	Turning off the boiler when leaving homes	Weekdays: Boiler off between 08:00 and 18:00 Weekends: No change

The base case scenario for the building construction and systems was defined according to the real condition of the building. Due to the lack of data about occupants' real use of the building, the base case scenarios for occupant building operation used the worst case behavioural condition, which is when all behaviour change options are not applied. Although this may not reflect the real operational condition of the case study house, these assumptions are acceptable in this paper as the main purpose here is to test whether BPS can provide consistent predictions of energy saving potential of all behaviour change options listed in Table 1 and 2, when compared with general expectations, not to provide accurate predictions for the case study house. The lack of occupants' real use of the building is an important challenge of using BPS in real applications and this will be discussed in the later discussion section. The occupancy and activities of the house occupant are defined in Table 5 for the simulation work.

Table 5. Definition of occupancy condition and activities.

Weekdays	00:00 – 07:00 Sleeping (Bedroom 1)	07:00 – 08:00 Breakfast (Kitchen)	08:00 – 18:00 Working (Unoccupied)	18:00 – 19:00 Dinner (Kitchen)	19:00 – 23:00 Relaxing (Living room)	23:00 – 24:00 Sleeping (Bedroom 1)
Weekends	00:00 – 08:00 Sleeping (Bedroom 1)	08:00 – 09:00 Breakfast (Kitchen)	09:00 – 18:00 Relaxing (Living room)	18:00 – 19:00 Dinner (Kitchen)	19:00 – 23:00 Relaxing (Living room)	23:00 – 24:00 Sleeping (Bedroom 1)

4 Results

The prediction of the energy saving potential of each behaviour change option was carried out by undertaking dynamic thermal simulations for the base case scenario and for the scenario applying that behaviour change option, and then comparing the energy used for heating the house.

4.1 Model validation

The case study house has an EPC rating of D in 2010, which is an average rating of UK homes. According to the Ofgem (2011), the average UK home consumes about 20,500 kWh per year for space heating. For the case study house, the simulated annual heating energy consumption is 22,562 kWh, about 10% more than the average level. This is reasonable as the occupant's operation of the building was defined using the worst case condition in the simulation, which will result in additional energy consumption. Based on these results, the model developed was considered to be suitable to carry out further simulations.

4.2 Prediction of energy saving potential

Figure 2 shows the prediction results for the 12 investment behaviour options, represented as a percentage of the base case energy consumption. The predictions show the positive impact of all investment behaviour change options on reducing the energy consumption for heating the house, but with varying magnitudes. For the case study house, adding external insulation (Option 1), improving the house air tightness (Option 5), installing energy-efficient heating systems (Option 10) and installing

smart heating controls (Option 11) show significant contributions on improving the building energy efficiency. Adding an unheated porch at the entrance of the house (Option 8), separating the indoor environment with the outdoor environment, can also contribute to reducing space heating demand by about 6%. Upgrading the insulation levels of the ceiling and the roof does not play well for the case study house, due to the existing insulation layer of the ceiling, which has separated the ceiling and roof with the indoor environment.

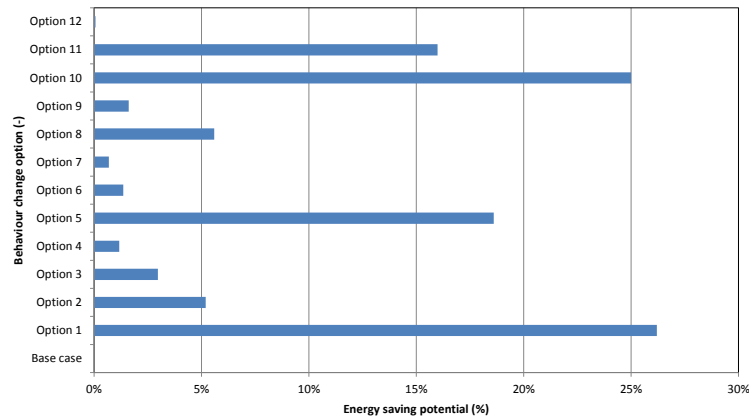

Figure 2. Prediction results for all change options of the investment behaviour.

Figure 3 shows the prediction results for the 16 curtailment behaviour options. The results reflect that improving building operation can also contribute to reducing house space heating demand, consistent with general expectations. According to the predictions, changing heating operation (Options 9 to 16) generally has a bigger impact than changing other behaviours, i.e. window operation, door operation and blind/curtain operation. Additionally, keeping the back door open also has a great impact on the house heating energy consumption, as reflected by the predictions for Options 5 and 6, due to the large opening area of the door. In a similar way, because the opening area of the window is small, the contribution of changing window operation (Options 1-4) on reducing the house space heating demand is moderate for the case study house. According to the predictions for Options 7 and 8, it seems that changing blind/curtain operation has little influence on the space heating demand of the case study house.

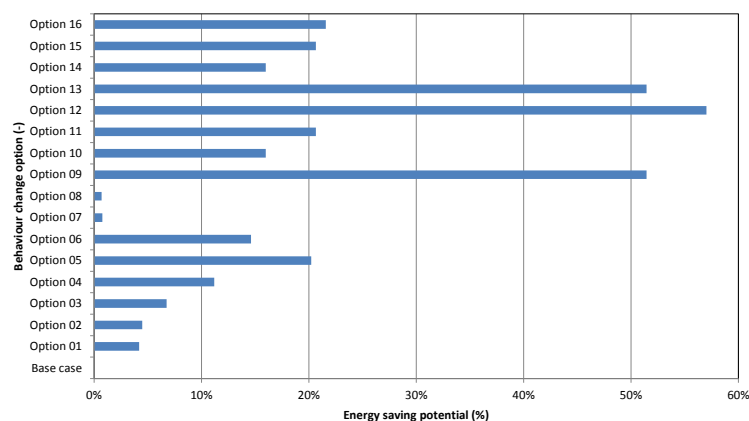

Figure 3. Prediction results for all change options of the curtailment behaviour.

5 Discussions

Reducing residential energy consumption is an important task for the UK government in the next 40 years, to achieve its own 2050 target for CO₂ emission reduction. This can be achieved by both changing occupants' use of the building/building systems and upgrading the building construction/systems. This study has tested the use of building performance simulation to predict the energy saving potential of a number of behaviour change options for a UK residential building. Although the prediction results are consistent with general expectations, meaning that BPS is capable of predicting the impact of changing behaviour on building energy demand, before being used to help real occupants make decisions on saving energy, the methodology still needs to be further improved in future studies, due to several challenges:

1. **Making building occupants enact the results from BPS.** Currently, BPS is mainly used by building designers and researchers to compare building performance between various systems. In real buildings, however, most building users/occupants are not experts in building science and technology, and have little knowledge about BPS. Thus, how to introduce BPS to the general public needs further exploration;
2. **Further capturing occupants' real behaviour on operating the building, so the base case simulation model can be developed as close as possible to real situations.** Due to the stochastic nature of occupants' real use of the building (Nicol and Humphreys, 2004), it is hard to accurately represent it in the building simulation process. Additionally, accurately monitoring occupants' building use is also a complex and expensive task. These issues have been officially raised in the new approved IEA ANNEX 66 project (IEA, 2014) and need to be solved in future studies; and,
3. **Realistically quantifying the behaviour change options.** Real applications are complex and technologies are improving. Therefore, how to provide a quantified and comprehensive list of behaviour change options based on real situations is also important, as this list will be the basis of defining simulation scenarios after behaviour change.
4. **Suitably limiting the behaviour change options.** For the curtailment behaviour, some behaviour change options will influence the indoor thermal environment greatly, such as Options 9-15. Therefore, when performing these options, a balance between building energy consumption and indoor thermal environment should be carefully considered, so as to not sacrifice comfort for saving energy. For the investment behaviour, as most behaviour change options can require significant financial investments, a balance between cost and energy savings becomes important to achieve.

An initial exploration on solving the above challenges is currently on-going by the authors of this paper.

6 Conclusions

Residential buildings contribute significantly to the UK's greenhouse gas emissions. Therefore, reducing residential energy consumption is an important task for the UK

government in the next decades. With respect to space heating energy consumption in winter, generally, there are two ways to save energy, either by performing curtailment behaviour or by applying thermal investment updates (investment behaviour). The curtailment behaviour is about changing occupants' use of the building or the building systems, whilst the investment behaviour relates to upgrading/retrofitting the building construction or the building systems. This paper has provided a comprehensive classification of behaviour change options for both curtailment and investment behaviours, and has tested the use of BPS to predict the potential impact of each behaviour change option on the space heating demand of a UK mid-terraced house.

The prediction results have revealed that building performance simulation has a potential of being used to predict the impact of all behaviour change options presented in this paper, as the prediction results are consistent with general expectations, hence could be used to help building occupants make decisions on changing behaviour to save residential energy. However, there are also several challenges for using this methodology in real applications and these challenges need to be sorted out in future studies.

Acknowledgement

The work reported in this paper is funded by the Engineering and Physical Sciences Research Council (EPSRC) under the Transforming Energy Demand in Buildings through Digital Innovation (TEDDI) eViz project (grant reference EP/K002465/1).

References

- DE WILDE, P., PAHL, S., HAMZA, N., WEI, S., JONES, R. & ABOHELA, I. 2013. Using building simulation to drive changes in occupant behaviour: A pilot study. *Building Simulation 2013 Conference*. Chambery, France.
- DEFRA 2006. Climate Change - The UK Programme 2006. London: Department for Environment, Food and Rural Affairs.
- DESIGNBUILDER. 2014. *DesignBuilder website* [Online]. Available: <http://www.designbuilder.co.uk/>.
- FABI, V., ANDERSEN, R. V., CORGNATI, S. & OLESEN, B. W. 2012. Occupants' window opening behaviour: A literature review of factors influencing occupant behaviour and models. *Building and Environment*, 58, 188-198.
- GARDNER, G. & STERN, P. 2002. *Environmental problems and human behaviour*, Boston, MA, Pearson Custom Publishing.
- GARDNER, G. T. & STERN, P. C. 2008. The Short List: The Most Effective Actions U.S. Households Can Take to Curb Climate Change. *Environment: Science and Policy for Sustainable Development*, 50, 12-25.
- GUERRA-SANTIN, O. & ITARD, L. 2010. Occupants' behaviour: determinants and effects on residential heating consumption. *Building Research & Information*, 38, 318-338.
- GUNAY, H. B., O'BRIEN, W. & BEAUSOLEIL-MORRISON, I. 2013. A critical review of observation studies, modeling, and simulation of adaptive occupant behaviors in offices. *Building and Environment*, 70, 31-47.

HAAS, R., AUER, H. & BIERMAYR, P. 1998. The impact of consumer behavior on residential energy demand for space heating. *Energy and Buildings*, 27, 195-205.

IEA. 2014. *IEA ANNEX 66* [Online]. Available: <http://www.annex66.org/>.

KIM, Y. K. & ALTAN, H. 2013. Using dynamic simulation for demonstrating the impact of energy consumption by retrofit and behavioural change *Building Simulation 2013 Conference*. Chambéry, France.

LOVE, J. 2012. Mapping the impact of changes in occupant heating behaviour on space heating energy use as a result of UK domestic retrofit. *Retrofit 2012*. Manchester, UK, 22-26 January.

MORLEY, J. & HAZAS, M. 2011. The significance of difference: Understanding variation in household energy consumption. *ECEEE 2011 Summer Study*. . Belambra Presqu'île de Giens, France, 6-11 June.

NICOL, F. J. & HUMPHREYS, M. A. 2004. A stochastic approach to thermal comfort - Occupant behaviour and energy use in buildings. *ASHRAE Transactions*, 110 (Part I), 554-568.

OFGEM 2011. Typical domestic energy consumption figures.

ROETZEL, A., TSANGRASSOULIS, A., DIETRICH, U. & BUSCHING, S. 2010. A review of occupant control on natural ventilation. *Renewable and Sustainable Energy Reviews*, 14, 1001-1013.

SHORROCK, L. D. & DUNSTER, J. E. 1997. The physically-based model BREHOMES and its use in deriving scenarios for the energy use and carbon dioxide emissions of the UK housing stock. *Energy Policy*, 25, 1027-1037.

WEI, S., JONES, R. & DE WILDE, P. 2014. Driving factors for occupant-controlled space heating in residential buildings. *Energy and Buildings*, 70, 36-44.

WINDSOR CONFERENCE 2014

COUNTING THE COST OF COMFORT

SESSION 8

The interaction between people and buildings

Invited Chairs: Pierre Lombard and Michael Adebamowo

Proceedings of 8th Windsor Conference: *Counting the Cost of Comfort in a changing world* Cumberland Lodge, Windsor, UK, 10-13 April 2014. London: Network for Comfort and Energy Use in Buildings, <http://nceub.org.uk>

Environmental Comfort in the Living Heritage of the Chilean Araucanía: The Ruka Lafkenche and the Fogón Pehuenche.

Christopher J. Whitman¹ and Neil Turnbull²

1 Laboratorio de Bioclimática, Facultad de Arquitectura, Urbanismo y Paisaje, Universidad Central de Chile. Santiago de Chile, cwhitman@uccentral.cl ;

2 Facultad de Arquitectura y Urbanismo, Universidad de Chile, Santiago de Chile, neil_jon_turnbull@hotmail.com

Abstract

Indigenous architecture's adaption to its climate and its use of local materials has attracted interest in the search for a sustainable built environment. In Chile surviving examples include the iconic *Ruka Lafkenche* and the little known *Fogón Pehuenche*. United by the world outlook of the Mapuche people, these two examples are located in different climates and as a result different construction systems have developed. This paper presents the results of a government funded research project, which studies their construction materials and techniques, and presents an evaluation of the previously unstudied internal environmental comfort. The results show that materials used are low carbon and locally resourced; open hearths achieve a comfortable globe temperature for those gathered around them; however they have little effect on the dry-bulb temperature and produce large quantities of ultrafine particulate matter. This poor indoor air quality presents a challenge for achieving internal environmental comfort. However the approach to the use of low impact, local, biodegradable materials is exemplary and provides valuable indications of how a sustainable and appropriate architecture might be developed for the Chilean Araucanía region.

Keywords: Indigenous architecture, environmental comfort, air quality, sustainable materials, Chile

1 Introduction

In today's globalized world, expressions of locality are becoming increasingly valued. According to official statistics, 40% of the 3,070,000 foreign tourists arriving in Chile in 2011 cited culture and heritage as their principal motivation for visiting (Bertin, 2012). Statistics for Chile's Araucanía region show that in the same year more than 80% of foreign tourists and 40% of national tourists requested information on activities specifically related to the region's indigenous Mapuche people (Sernatur 2012). In this context the Mapuche dwelling or *ruka* has become the icon for the international promotion of the region (Sernatur 2012). For centuries the *ruka* has formed an important part of Mapuche cultural identity; a symbol and tradition that exists until today. However within Chile the architecture of its original inhabitants receives little recognition. Wainsberg (1978) in his book "*En torno a la historia de la arquitectura Chilena*" begins the history of Chilean architecture with the colonial architecture of the Spanish conquistadores, whilst Gross (1978) in "*Arquitectura en Chile*" dedicates only 3 pages to the Mapuche *ruka* illustrating only the most well known typology, that of the *Lafkenche* coastal tribes. These omissions have been to some extent rectified with the publication of the Ministry of Public Works Mapuche

design guide for public buildings and spaces (MOP 2003). The guide sets out the world view of the Mapuche and specifies the distinct styles, forms and spatial planning of their constructions with the aim to integrate this information in the design of public infrastructure intended for their use. The guide however focuses on formal aspects, thereby leaving an important characteristic of Mapuche architecture unexplored, namely its adaptation to climatic and geographic conditions in order to provide comfort and habitability which has been developed over centuries.

1.1 The Study of Vernacular and Indigenous Architecture: A Global Perspective

In the 19th century the study of vernacular and indigenous architecture in Europe focused on the search for a national style and identity, whilst the study of oriental indigenous architecture and that of the southern hemisphere was purely anthropological (Arboleda 2006). In the 20th Century, architects such as Adolf Loos, Le Corbusier and Frank Lloyd Wright referred to vernacular architecture in their theories on form and composition, whilst the exhibition “*Architecture without Architects*” at the Museum of Modern Art in New York and the accompanying book (Rudofsky, B. 1968), highlighted the aesthetic qualities of the vernacular. Towards the end of the 1960s research and publications such as “*Shelter and Society*” (Oliver 1969) and “*House Form and Culture*” (Rapoport 1969) began to focus on the cultural and social aspects of vernacular and indigenous architecture. Since the 1990s academics (Ubbelohde 1991, Cook 1996, Zhai & Previtali 2009, Huang & Lui 2010, Foruzanmehr & Vellinga 2011) have studied the performance of vernacular and indigenous architecture within the context of sustainability and the search for a low energy architecture with less environmental impacts. Vernacular architecture is now appreciated for its environmental principals and bioclimatic concepts. In this way its study is useful for those engaged in the design of the built environment (Rapoport 2006). However the sustainability of vernacular and indigenous architecture has been idealized (Arboleda 2006) and it is therefore necessary to obtain empirical measurements of its performance in use to allow the application of its advantages and the avoidance of its drawbacks.

1.2 The Mapuche *rukas*

Table 1. Characteristics of the *rukas* of the different branches of the Mapuche people.

	Plan form	Roof material	Wall material	Door location	Windows
Picunches People of the North	Rectangular or oval	Thatch	Wattle and daub (<i>quincha</i>) or vertical boards	One facing east	No
Lafkenche People of the sea	Oval or circular	Thatch	Straw or reeds	One facing east	No
Nagche People of the plains	Oval	Thatch	Vertical boards or posts	One facing east	No
Pehuenche People of the Pehuen (fruit of the Araucaria tree)	Rectangular or circular	Hollowed tree trunks	Hollowed tree trunks	One facing east	No
Williche People of the south	Rectangular	Thatch	Horizontal boards	Two one facing east the other west	Yes

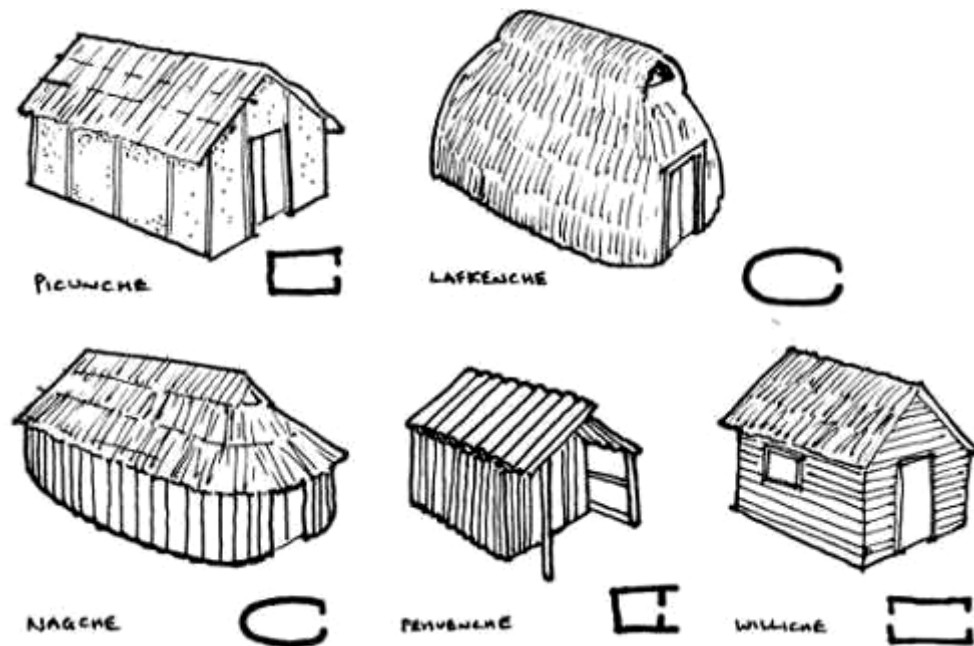

Figure 1: The *rukas* of the different branches of the Mapuche people. *Source*: Diagram by C. Whitman

The *ruka* of the Mapuche (People of the Earth *mapu*-earth, *che*-people) is the most representative architectural element of the Mapuche world. It symbolizes the *nag mapu*, the domestication of the natural environment, the most important space for the meeting and participation of the community (MOP 2003). A fundamental Mapuche concept is the temporality of their constructions; they are ephemeral, made of only natural biodegradable materials with little elaboration. The form and materials of the *rukas* of the different branches of the Mapuche people (Table 1 & fig.1) depends on the climate and the materials locally available. This paper presents a study of the *rukas* of just two branches, the Lafkenche and the Pehuenche.

1.2.1 The Lafkenche *ruka*

The *rukas* of the Lafkenche or People of the Sea are built on the tops of the low coastal hills. These raised locations provide good visibility to avoid surprises from enemies and protection from flooding (Otero 2006). The construction of a *ruka* is a communal task or *mingaco*. Following the completion of the main structure the owner offers the workers a meal with meat, bread and *mudai* or *chicha*, alcoholic drinks made from fermented wheat, corn, apples or pine nuts. Another meal is offered following the completion of the thatching. It is said that between the completion of the structure and thatching sufficient time is always left in order to prepare sufficient meat and *chicha* [Coña 2002]. The *ruka encolihuada* predates the contemporary *ruka*. This consisted of a conical structure constructed around a central vertical pole (Coña 2002). Today the *rukas* are oval in plan with a primary structure of tree trunks. Forked trunks or *taras* form vertical posts supporting horizontal beams culminating in the ridge beam or *kuikuipani* (Coña 2002) (fig.2). This primary structure supports a secondary structure of thinner trunks and branches which is in turn thatched with ratonera grass (*Hierochloe utriculata*), sedge (*Schoenoplectus californicus*) or tree suckers. The thatch is placed starting at the bottom, working upwards so that the second row overlaps and covers most of the first. “Immediately below each end of the ridge beam they leave corresponding openings, these holes of the house allow the smoke to escape and provide roosts for the chickens” (Coña 2002). There is one doorway which is orientated towards the East, towards the rising sun. The prevailing winds are from

the South and from the North in winter. The orientation of the openings and doors provide protection from these winds. Coña claims that historically there was no need to close this opening as robberies were unheard of and that closing doors were only introduced with the arrival of the Spanish to prevent theft.

Traditionally there were no subdivisions within the *ruka*, the space being organized around the open hearth. In contemporary constructions a low division made of local bamboo has been introduced to divide the sleeping and living areas. The smoke and soot from the open fire plays a fundamental role in the preservation of the construction materials, impregnating both the timber and the thatch.

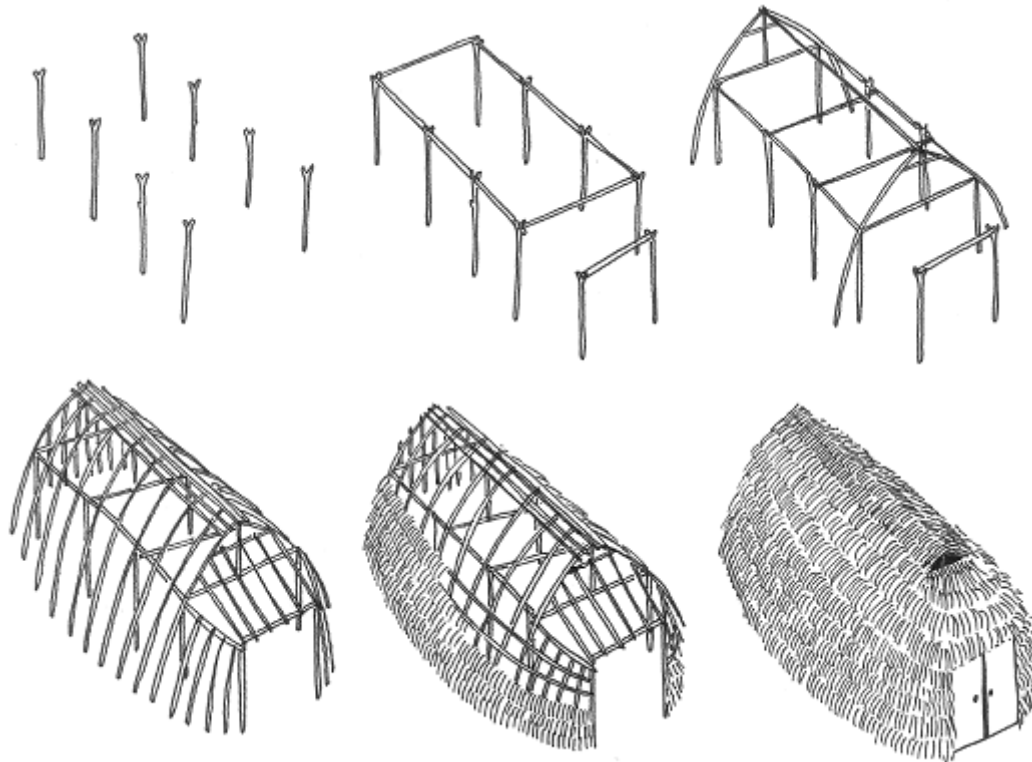

Figure 2: Construction sequence of a Lafkenche *ruka*. Source: Diagram by C. Whitman

1.2.2 The *rukas* and *fogones* of the Pehuenche

The *rukas* and *fogones* of the Pehuenche are very different from those of the other Mapuche people and little written information exists about them. They are constructed from straight hollowed half tree trunks in the form of canoes. These canoes or *wampos* are placed like clay roof tiles to form walls and roofs. Those used for the roof have brackets carved at their bases so that they rest on the horizontal beam of the post and beam structure (Fig.3). When well constructed the placement of the *wampos* avoid gaps between one element and the other. In the case that gaps occur these are infilled with smaller timbers. Traditionally the logs were split along the grain using wedges of the hardwoods *meli* (*Amomyrtus meli*) or *luma* (*Amomyrtus luma*) and mallets of the same timbers (Otero 2006).



Figure 3. Detail of construction of Pehuenche *fogón*.

1.3 Objectives

This paper presents the results of the government funded project Fondart N° 1685 “*Confort ambiental en el patrimonio vivo de la Araucanía: La ruka Lafkenche y el fogón Pehuenche*” (Environmental comfort in the living heritage of the Araucanía: The Lafkenche Ruka and the Pehuenche Fogón) which studied the construction techniques, materials, use and environmental comfort of the *rukas* Lafkenche and Pehuenche located in Llaguepulli and Quinquén respectively, both in the Araucanía Region of Southern Chile.

2 Methodology

A bibliographic study was made of Mapuche architecture prior to study trips to the Lafkenche community Llaguepulli by the coast and the Pehuenche community of Quinquén in the Andes. The first study trip was undertaken 20th-25th July 2013 during the Chilean winter. The second study trip took place 2nd-7th January 2014 during the Chilean summer. Measurements were made of dry-bulb air temperature, relative humidity and concentrations of CO₂ with a combined digital hygrothermometer/CO₂ meter Extech CO200; black globe temperature with a digital black globe thermometer Sper Scientific 800037; radiant surface temperature with an infrared thermometer Raytek MinitempMT6; thermal imaging with a thermal imaging camera Fluke TiR; natural daylighting with a digital light meter Hibok 35; and air quality in the form of concentrations of ultra-fine particulate matter with a P-Trak 8525. The results of these measurements are presented below.

In addition to specific in situ measurements, wireless hygrothermic data loggers iButton DS1923-Hygrochron were used to take continual measurements of dry-bulb air temperature and relative humidity. In Llaguepulli, to determine differences in air temperature according to distance from the open fire, data loggers were hung 1.7m above finished floor level, one 1m in plan from the fire and another at the furthest point from the fire. An additional data logger was installed externally, protected from direct sunlight, wind and rain. Concurrent continual measurements of black globe

temperature were also taken for a period of 24 hours with readings at hourly intervals (Fig 7).

Following these measurements, further measurements were undertaken to determine if the interior spaces can be defined as homogeneous or heterogeneous with regards to the horizontal stratification of temperatures as defined by the International Standard ISO 7726:1998 Ergonomics of the thermal environment - Instruments for measuring physical quantities (CEN 2002). Following the Standard, data loggers were installed at 0.1m, 1.1m and 1.7m above finished floor level, 2m in plan from the open fire. Measurements were taken for a period of 24 hours at 5 minute intervals (Fig 8).

For the long term continuous measurements data loggers were installed 2m in plan from the open fire at three heights, 0.1m, 1.1m and 1.7m. In addition sensors were installed externally, in a second *ruka* and an adjacent timber cabin at a height of 1.1m. The sensors were left for a period of 3 months, 22nd July- 1st October 2013. The results (figures 12-15) are presented in the form of psychrometric charts (GIVONI 1998).

In January 2014 summer conditions were monitored with the sensors reinstalled in the same positions. Measurements were recorded for a period of 48 hours at an interval of 5 minutes (figure 9). The sensors were then reinstalled for hourly measurements 4th January- 26th February 2014 (Figs 16-19).

In Quinquén continuous measurements were undertaken of dry-bulb temperature and relative humidity with sensors installed 2m in plan from the open fire at a height of 0.1m, 1.1m and 1.7m. The first measurements were for a period of 22 hours at 5 minutes intervals (Fig. 25). These were followed by hourly measurements 25th July - 30th September 2013 (Figs. 30&31) and 1st November 2013- 6th January 2014 (figures 26&27).

2.1 Interviews with owners

Interviews were conducted with each of the owners regarding construction, use and their perceptions of environmental comfort within the *rukas*. It is important to stress that these perceptions are based primarily on their memories of a time when they lived in *rukas*. Continual occupation of the *rukas* in this region ended during the 1990s when government subsidies were made available for the construction of social housing. Today most people do not live in their *rukas*, reserving them for special events, meetings and celebrations or for visitors.

3 Data and Analyses

3.1 Data and Analyses of *rukas* Lafkenche

3.1.1 Climatic Conditions, Llaguepulli, Lago Budi 38° 56'S, longitude 73° 16'W

According to the Chilean Standard NCh1079. Of 2008 (INN 2008) the climate of coastal Araucanía Region is classified as “Southern Coastal” a “zone of maritime climate, rainy. Long winters. Ground and environment saline and humid. Strong winds mainly westerly. Robust vegetation. Temperature temperate to cold.” The average temperatures are presented in Table 2.

Table 2: Temperatures of Coastal Araucanía Region [Uribe et al. 2012]

	Jan	Feb	Mar	Apr	May	Jun	Jul	Aug	Sep	Nov	Oct	Dec
T (°C)	16	15,5	14	12	10	8,5	7,9	8,3	11,8	9,8	13,8	15,4
Tmax (°C)	21,9	21,3	19,4	16,8	14	11,9	11,1	11,8	13,7	16,4	19,1	21,1
Tmin (°C)	10,2	9,7	8,7	6	7,3	5	4,6	4,9	5,8	7,1	8,5	9,6

3.1.2 Rukas Lafkenche, Ina Lewfu (Lake Shore)

Sr. Ramón 2° Lefio Maripan and his wife Sra. Selma Caniuñir own two *rukas*, *ruka grande* (figs. 4&5) and *ruka chica* built 6 and 3 years ago respectively, in which they offer tourist accommodation. Don Ramón was born and raised in a *ruka* with his 12 brothers and sisters. There existed no internal divisions except for two compartments constructed on either side of the door, one for wheat and the other for potatoes. He remembers the *ruka* as warm and cosy in winter and neither cold nor hot in summer. When his mother first received government funding for a zinc clad house the family continued to live in the *ruka* using the zinc house only for sleeping. In summer they would go to *ruka* to escape the heat of the zinc house. Don Ramón did however comment that the zinc house changed their way of life, there was no smoke, but the *ruka* was always warm.



Figure 4: Author and Sra. Selma Caniuñir outside the *ruka grande*. Figure 5. Interior of the *ruka grande*.

3.1.2.1 Specific in situ measurements: Ina Lewfu

Table 3: Specific measurements Ina Lewfu 20, 21 and 23 July 2013. (f) Fire lit, (u) Fire unlit.

Date 2013	Hour	Location	Dry-bulb temperature (°C)	Black Globe Temperature (°C)	Radiant surface temperature (°C)						Relative humidity (%)	CO ₂ (ppm)	Ultra fine particulate material (particles/cm ³)
					North	East	South	West	Ceiling	Floor			
20/07	15:50	Exterior	8.3	7.7	-	-	-	-	-	-	55.0	493	-
		Ruka chica (f)	11.2	19.8	10.4	10.0	9.6	11.2	16.6	9.8	54.3	570	360,000
	17:00	Exterior	8	-	-	-	-	-	-	-	55.0	494	7000
		Ruka chica (f)	13.5	24.1	10.2	12.4	10.0	11.2	15.2	10.0	46.5	714	>500,000
	18:50	Exterior	5.5	-	-	-	-	-	-	-	65.3	495	-
		Ruka chica (f)	12.5	25.0	12.0	14.0	13.0	12.6	19.2	12.2	53.2	704	>500,000
21/07	07:50	Exterior	1.1	-	-	-	-	-	-	-	85.0	505	3550
		Ruka chica (u)	2.6	2.2	2.4	1.4	2.4	2.4	2.2	4.8	75.0	508	3400
	12:40	Exterior	6.6	-	-	-	-	-	-	-	58.6	-	-
		Ruka chica (f)	11.5	20.6	9.0	10.6	10.8	9.8	15.0	8.8	56.3	626	>500,000
	13:20	Exterior	7.4	-	-	-	-	-	-	-	50.0	505	7420
		Ruka grande (f)	11.2	18.5	5.8	8.2	8.4	4.8	23.6	8.4	50.6	678	358,860
	16:20	Exterior	7.2	-	-	-	-	-	-	-	46.4	491	-
		Ruka grande (f)	10.4	17.8	10.0	11.0	13.4	7.6	20.0	10.4	53.2	557	-
23/07	10:15	Exterior	7.0	-	-	-	-	-	-	80.2	524	-	
		Cabin (f)	11.0	12.6	8.8	10.6	10.4	10.2	11.8	10.4	67.5	926	18,100

The winter results (Table 3) show that the internal dry-bulb temperatures are on average 4°C higher than the external temperature. Even in the morning prior to lighting the fire the temperature was 1.5°C higher. Whilst dry-bulb temperatures are well below the comfort zone (Givoni 1998), the black globe temperatures fall consistently within the zone when the open hearth is lit. Wall radiant surface temperatures are close to the dry-bulb temperatures as would be expected from a low thermal mass structure, whilst that of the mass of the earthen floor is higher and that of the ceiling shows a horizontal stratification of the heat. Concentrations of CO₂ show there is sufficient ventilation, however concentrations of ultra-fine particles are extremely high.

Table 4: Specific measurements Ina Lewfu 2, 3 and 4 January 2014. (f) Fire lit, (u) Fire unlit.

Date 2014	Hour	Location	Dry-bulb temperature (°C)	Black Globe Temperature (°C)	Radiant surface temperature (°C)						Relative humidity (%)	CO ₂ (ppm)	Ultra fine particulate material (particles/cm ³)
					North	East	South	West	Ceiling	Floor			
02/01	17:35	Exterior	14.4	14.9	-	-	-	-	-	-	55.8	487	440
		Ruka chica (u)	16.1	15.9	-	-	-	-	-	-	51.7	491	995
03/01	10:40	Exterior	14.4	-	-	-	-	-	-	-	51.7	472	4470
		Ruka chica (u)	14.8	14.8	12.9	13.9	11.2	12.0	13.3	10.8	54.0	485	3450
	12:20	Exterior	14.8	29.2	-	-	-	-	-	-	47.9	486	4300
		Ruka chica (u)	15.9	15.5	13.2	14.0	11.9	12.3	13.9	12.3	48.6	500	5170
	15:30	Exterior	15.7	-	-	-	-	-	-	-	49.1	484	2140
		Ruka chica (u)	16.2	15.8	14.3	14.4	13.4	16.4	14.3	11.7	51.4	502	1620
		Ruka grande (u)	16.0	-	13.0	13.7	12.8	12.8	13.9	11.6	50.7	499	1040
		Cabin (u)	18.8	-	15.7	17.8	16.9	20.5	21.2	16.3	50.4	520	2900
04/01	10:10	Exterior	20.0	-	-	-	-	-	-	-	60.8	495	500
		Ruka chica (u)	18.2	17.1	14.1	15.3	14.3	14.2	17.8	12.7	62.8	516	375
		Ruka grande (u)	17.1	-	13.5	15.0	13.6	14.0	16.7	12.0	66.0	511	2010
		Cabin (u)	19.0	-	16.1	14.9	15.5	14.6	22.3	14.1	48.7	517	1030
	12:40	Exterior	20.9	-	-	-	-	-	-	-	68.2	478	6480
		Ruka chica (u)	20.5	18.4	16.7	17.0	16.5	18.0	17.0	15.2	65.3	492	4890
		Ruka grande (u)	18.7	-	15.3	17.0	15.8	16.0	19.8	13.1	68.6	497	5420
		Cabin (u)	21.5	-	19.9	20.3	20.0	19.7	24.8	19.0	60.0	496	6300
	15:30	Exterior	20.8	-	-	-	-	-	-	-	64.7	496	359
		Ruka chica (u)	19.9	19.4	18.2	18.0	17.8	20.8	17.3	15.7	67.9	502	337
		Ruka grande (u)	19.5	-	17.0	17.6	17.0	17.0	18.9	14.4	69.1	499	1310
		Cabin (u)	22.7	-	22.9	22.4	22.0	26.0	28.0	22.0	60.3	496	6510

The summer results (Table 4) show internal dry-bulb temperatures of the *rukas* equal or inferior to external temperatures, whilst those of the timber cabin are superior but do not indicate a problem with overheating. Only the radiant surface temperature of the ceiling of the cabin on the 4th of January hints at the potential for overheating. Thermal imaging of the ceiling showed irregular surface temperatures suggesting non-continuous insulation. Internal concentrations of ultra-fine particles are similar to external levels when the open hearths are unlit confirming that these are the primary source of this contamination.

		0,3%	0,2%	0,2%	0,2%	0,1%	0,1%										
		0,3%	0,3%	0,2%	0,2%	0,2%	0,4%	0,5%									
	0,2%	0,3%	0,3%	0,3%	0,3%	0,3%	0,6%	1,0%	1,9%	2,9%	2,3%	1,7%					
0,1%	0,2%	0,3%	0,3%	0,3%	0,3%	0,3%	1,5%	2,6%	3,7%	4,7%	5,1%	5,6%	8,3%	11,9%			
0,3%	0,3%	0,3%	0,3%	0,3%	0,3%	0,3%	2,3%	4,3%	5,4%	6,6%	8,0%	9,4%	16,6%	23,7%			
0,3%	0,3%	0,3%	0,3%	0,3%	0,3%	0,3%	2,7%	5,0%	7,0%	9,0%	10,4%	11,9%	19,9%	28,0%			
0,3%	0,3%	0,3%	0,3%	0,3%	0,3%	0,4%	3,0%	5,7%	8,6%	11,4%	12,9%	14,3%	23,3%	32,3%			
0,2%	0,3%	0,3%	0,3%	0,3%	0,4%	0,5%	2,5%	4,5%	6,7%	9,0%	10,6%	12,1%	21,3%	30,4%			
0,2%	0,3%	0,4%	0,3%	0,3%	0,5%	0,7%	1,9%	3,2%	4,9%	6,6%	8,3%	10,0%	19,3%	28,6%			
0,1%	0,2%	0,3%	0,3%	0,3%	0,4%	0,5%	1,3%	2,0%	2,9%	3,8%	4,5%	5,2%	9,6%	14,3%			
	0,1%	0,3%	0,3%	0,3%	0,3%	0,4%	0,6%	0,9%	0,9%	1,0%	0,7%	0,3%					
		0,3%	0,3%	0,3%	0,3%	0,3%	0,4%	0,4%									
		0,3%	0,3%	0,3%	0,2%	0,2%	0,1%										

Figure 6: Distribution of daylight factor within the *ruka chica* 21 July 2014

Natural daylight (Fig.6) is concentrated around the open door which corresponds to the area around the open hearth. The contribution of the roof openings is negligible.

3.1.2.2 Continual Measurements: Ina Lewfu

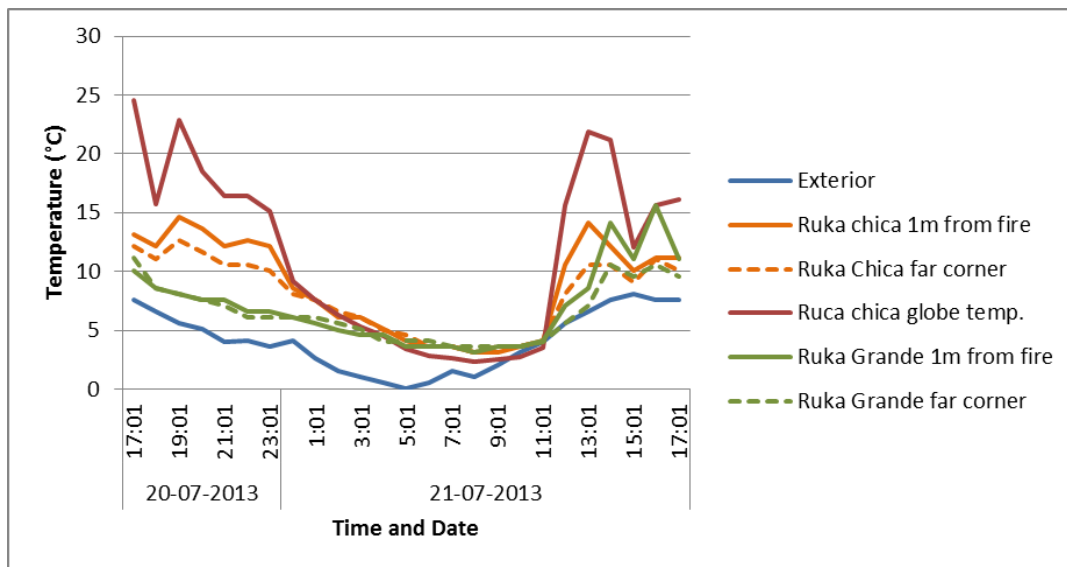

Figure 7: Simultaneous measurements of dry-bulb temperature and globe temperature at different points in plan. Ina Lewfu 20th-21st July 2013 (Austral Winter)

When the open hearth is lit in the *ruka chica* its radiant heat is clearly recorded by the black globe temperature (Fig. 7), the difference in dry-bulb temperature according to distance from the hearth reaches a maximum of 0.5°C and the difference with the external dry-bulb temperature a maximum of 7°C. Only the globe temperature achieves comfort levels.

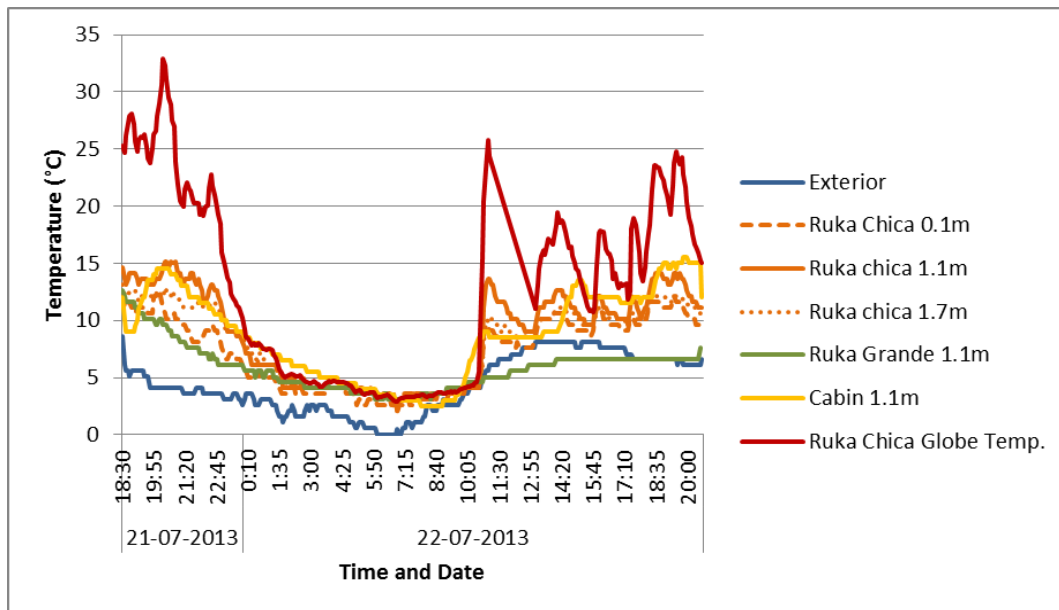

Figure 8: Simultaneous measurements of dry-bulb temperature and globe temperature. Ina Lewfu 21st-22nd July 2013 (Austral Winter)

Again the radiant heat of the hearth is clearly illustrated by the globe temperature (Fig.8) which at one point even exceeded the comfort zone. The dry-bulb temperature is highest at 1.1m above floor level reaching 15.1°C, 4.5°C higher than the dry-bulb temperature at 0.1m, 2.5°C higher than that at 1.7m and 11°C higher than the outdoor temperature. This indicates horizontal thermal stratification and that the space should be considered as heterogeneous for thermal measurements according to ISO 7726:1998 (CEN 2002). The indoor temperature of the cabin is similar to that of the *ruka chica*. The open hearth in the *ruka grande* was not lit on the 22nd resulting in temperatures lower than the exterior.

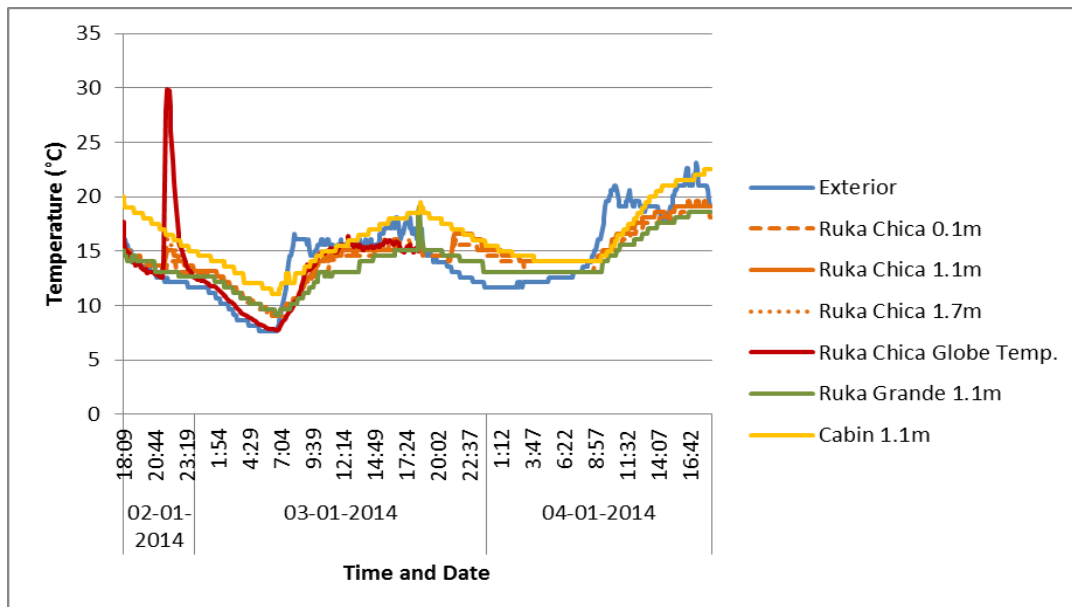

Figure 9: Simultaneous measurements of dry-bulb temperature and globe temperature. Ina Lewfu 2nd-4th January 2014 (Summer)

In summer the results (Fig. 9) show little horizontal stratification with the dry-bulb temperatures at 1.1m and 1.7m identical, between 1°C and 0.5°C higher than that at

0.1m. Only when the open hearth is lit do the temperatures at 1.1m and 1.7m diverge achieving a 1°C difference between the two, whilst the globe temperature rises to almost 30°C. Internal temperatures in the rukas are more stable than both the external and the interior temperature of the timber cabin.

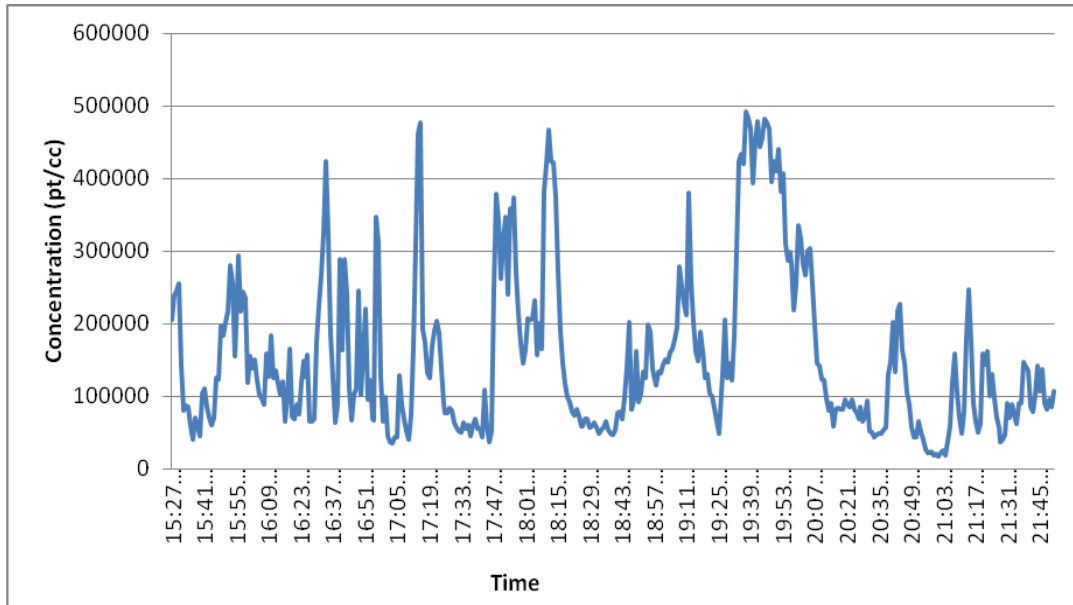

Figure 10: Measurements of concentration of ultra fine particulate matter in the ruka chica, Ina Lewfu 22nd July 2013 (Austral Winter) with open hearth lit.

The results (Fig.10) show high concentrations of ultra-fine particulate matter with peaks of almost 500,000 particles per cubic metre (pt/cc) and an average of 154,000 pt/cc over the 6 hour period. The levels decrease after 20:00 when the occupants go to bed and no further firewood is added.

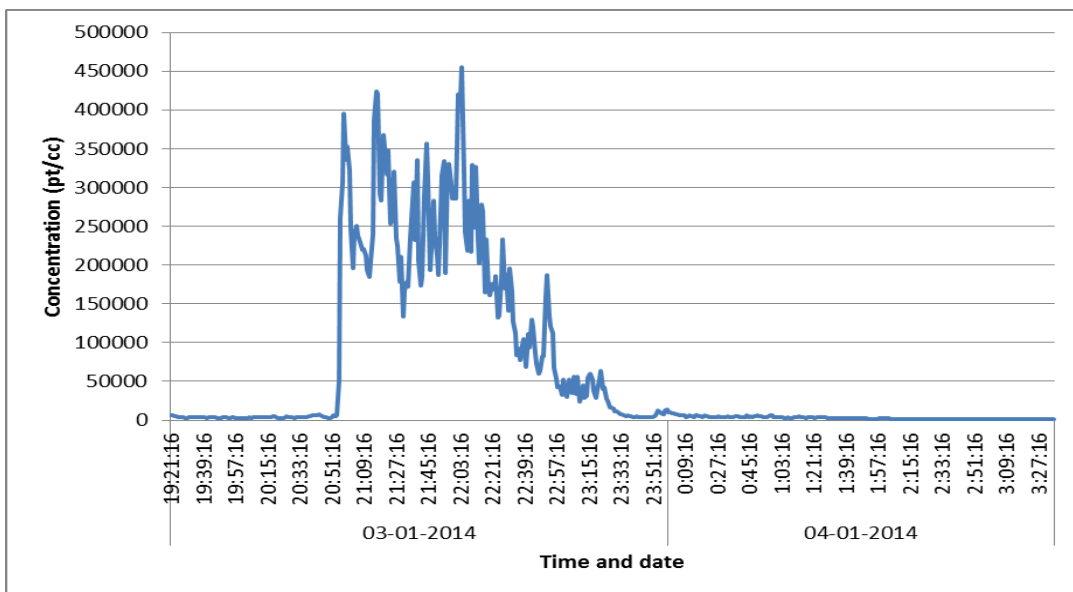

Figure 11: Measurements of concentration of ultra fine particulate matter in the ruka chica, Ina Lewfu 3rd-4th January (Austral Summer).

This graph (Fig. 11) graphically illustrates the impact of igniting the open hearth on the concentration of ultra-fine particulate mater, with concentrations rising to 100 times the background level in only three minutes.

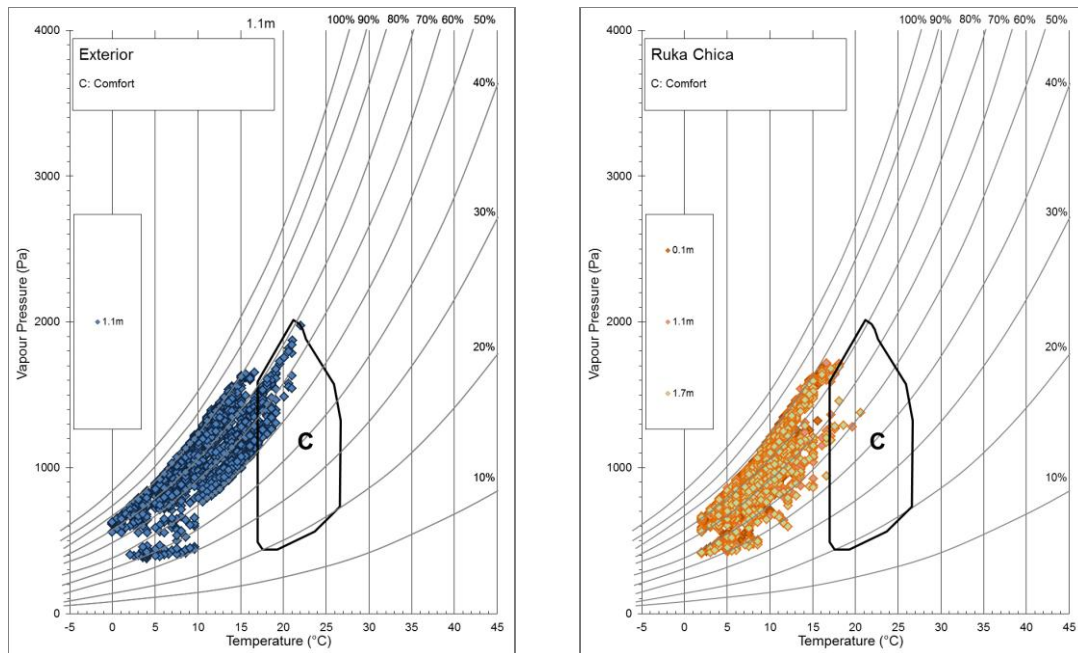

Figure 12 & Figure 13: Psychrometric charts showing temperature and relative humidity of the air externally and in the *ruka chica* from July to September 2013

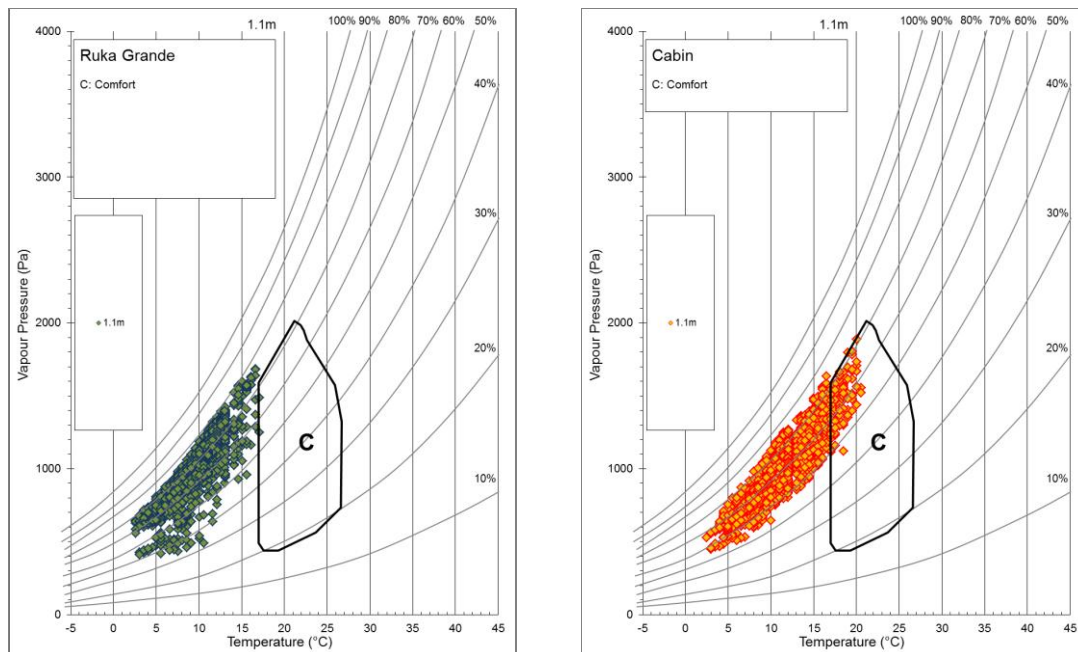

Figure 14 & Figure 15: Psychrometric charts showing temperature and relative humidity of the air in the *ruka grande* and timber cabin from July - September 2013.

The results (Figs. 12-15) show that in winter neither *ruka* achieves hygrothermal comfort (Givoni 1998) except on 12 isolated occasions. For 6% of the time external conditions are more favourable than interior. The *rukas* do however provide

protection from the lowest temperatures maintaining 2.5°C, the same as the timber cabin whilst external temperatures drop to 0°C.

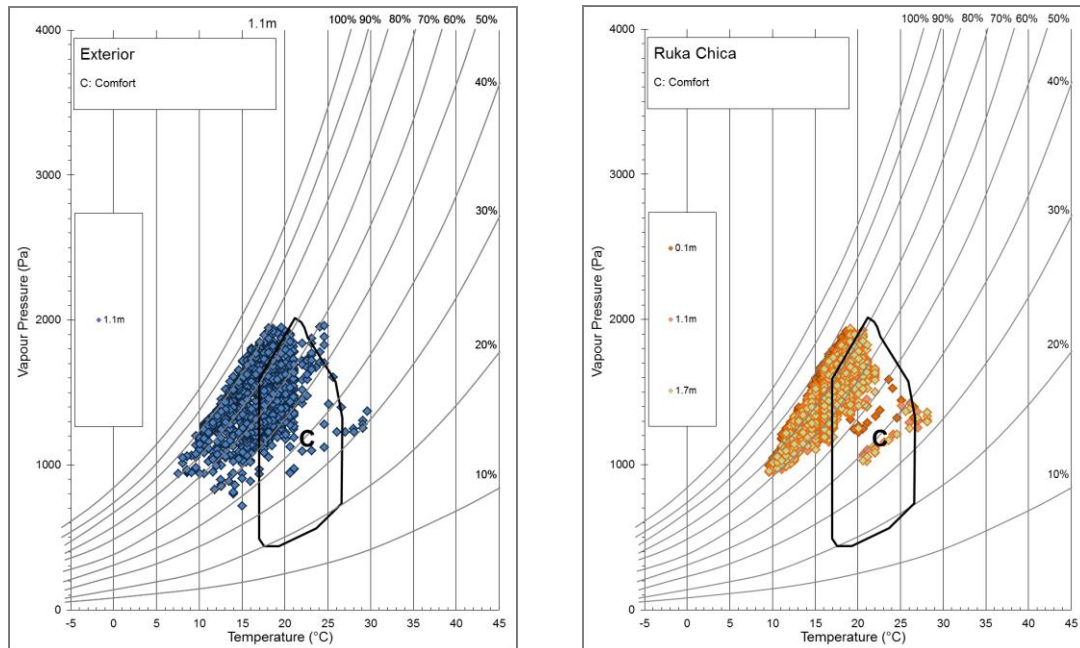

Figure 16 & Figure 17: Psychrometric charts showing temperature and relative humidity of the air externally and in the *ruka chica* from 4th January to 26th February 2014 (Austral Summer).

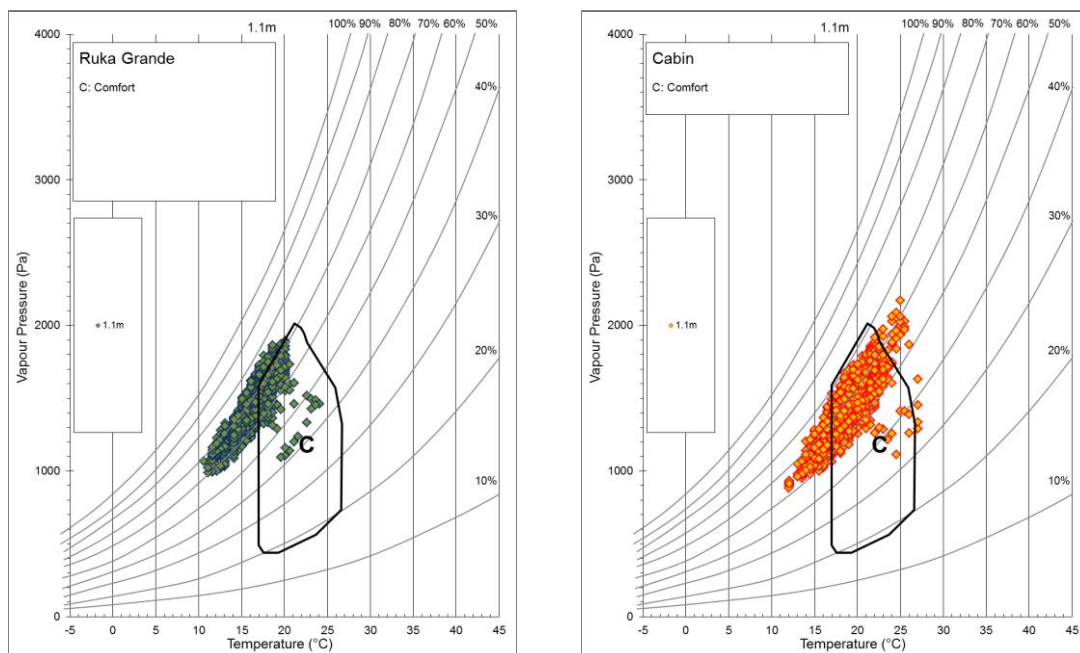

Figure 18 & Figure 19: Psychrometric charts showing temperature and relative humidity of the air in the *ruka grande* and timber cabin from 4th January to 26th February 2014 (Austral Summer)

The hourly summer measurements (Figs 16-19) show that temperatures in both *rukas* are similar to those externally, except for the extremes, where internal temperatures remain 2°C higher at the lower extreme and in general 3.5°C lower at the higher. Overheating in the *ruka Chica* is only experienced on one day when external temperatures reach 30°, whereas some overheating is experienced in the timber cabin. This corroborates the interviewee's opinion that the *rukas* are cooler in the summer than the new timber, zinc roofed houses. In general the relative humidity is high both internally and externally.

3.1.3 *Ruka Lafkenche, Ad Lewfu (Lake View)*

The family Paineofil own 3 *rukas* (Figs 20&21), offering tourist accomodation, meetings spaces and craftwork. The daughter of the family Srta. Nadia Paineofil was interviewed. Up until the early 1990s Nadia lived in a *ruka* until the age of 5 with her parents and 3 siblings. According to Nadia the *ruka* was comfortable both in winter and summer. She noted however that “the body becomes acustomed to the cold” and that in winter the family would always gather around the fire drinking maté. This time spent together around the fire is something that is missing today with the modern houses, in addition in summer the modern houses can overheat but the *rukas* don’t.

Specific in situ measurements in winter showed internal dry-bulb temperatures equal to external temperatures when the hearth was unlit.



Figure 20: Srta. Nadia Paineofil outside the *ruka* Ad Lewfu. Figure 21. Sr. Pablo Pablo Calfuqueo Lefio outside the *ruka* of Ad Mapulawen.

3.1.4 *Ruka Lafkenche Mapulawen (Medicinal Garden)*

The Calfuqueo family owns two *rukas* that they use for meetings and for receiving visitors to their medicinal herb garden. The son Sr. Pablo Calfuqueo Lefio was interviewed; he has been an important force behind the development of tourism as an alternative economic generator for the community. Pablo was born and grew up in a *ruka* until the age of 12. There were no divisions in the *ruka* except for pens for small fowl on either side of the door. The thermal sensation was one of comfort both in summer and in winter. Pablo noted that the *rukas* of his childhood were better insulated and that the thick layer of soot that built up helped seal the walls and further insulate. The lack of artificial lighting was not a problem as work activities were governed by the sunlight. The evenings were spent gathered around the open fire. Prior to 2000 all the *rukas* had disappeared from the community. The first new *rukas* were built at first to attract tourists, however in the last few years families have started to build their own new *rukas* for their own use for special occasions and family gatherings.

Specific in situ measurements in winter showed an internal dry-bulb temperature of 12.1°C with the hearth lit, 4.3°C higher than the external temperature.

3.2 Data and Analyses of *rukas* Pehuenche

3.2.1 Climatic Conditions Quinquén, Lago Galletue, alt. 1151m above sea level, 38° 40'S, 71° 17'W

According to the Chilean Standard NCh 1079. Of 2008, the climate of the Andean zone of the Araucanía Region is classified as “Andean”, a zone made up of many subzones currently little studied given the low population density. In general the zone has a dry atmosphere with large diurnal temperature oscillations. Blizzards and snow in winter. High altitude vegetation. High percentage of ultraviolet in the solar radiation. In general the conditions are severe (INN 2008). The temperatures for the border crossing located 20km from Quinquén are presented in Table 5.

Table 5: Average, Maximum and Minimum Temperatures Liucura [Dirección de Aguas 2012]

VARIABLE	Jan	Feb	Mar	Apr	May	Jun	Jul	Aug	Sep	Nov	Oct	Dec
T (°C)	26,1	24,3	23,3	18,6	14,0	9,1	8,1	8,8	13,7	16,7	18,9	23,9
Tmax (°C)	15,4	14,6	13,2	9,7	6,5	3,1	1,1	1,9	6,4	8,7	9,9	13,7
Tmin (°C)	4,7	5,0	3,0	0,8	-1,0	-3,0	-6,1	-5,1	-0,9	0,8	0,9	3,6

3.2.2 Fogón of Sr. Crescencio Meliñir

Sr. Crescencio Meliñir (Figs.22-23) is 68 years old. He was born and lived in a *ruka* until the 1990s when subsidies were provided for rural social housing by the government following the return of democracy to Chile. The current small *ruka* or *fogón* (hearth) was built three years ago by his son Alex Meliñir who has been influential in the development of eco/ethno tourism in the community. The new *fogón* which is approximately 4m square reused many timbers from a pre-existing barn. Currently Don Crescencio and his wife use the *fogón* for cooking and spend most of the evenings there by the fireside drinking mate. According to Don Crescencio traditional Pehuenche *rukas* and *fogones* were often lined with *quila*, a local bamboo, to provide additional insulation, although this increased the risk of house fires. When well-constructed, the *rukas* maintained the heat well. The current *fogón* is built with more ventilation principally for summer use. Don Crescencio claims that the smoke was never a problem, although recently an eye injury has been irritated by the smoke.



Figure 22: Author and Sr. Crescencio Meliñir outside his *fogón*. Figure 23: Don Crescencio inside *fogón*.

3.2.2.1 Specific in situ measurements: Fogón of Don Crescencio

Table 6: Specific in situ measurements Fogón de Don Crescencio, 24 July 2013

Date 2013	Hour	Location	Dry-bulb temperature (°C)	Black Globe Temperature (°C)	Radiant surface temperature (°C)						Relative humidity (%)	CO ₂ (ppm)	Ultra fine particulate material (particles/cm ³)
					North	East	South	West	Ceiling	Floor			
24/07	12:00	Exterior	6,4	-	-	-	-	-	-	-	35,4	406	1654
		Fogón (f)	10,2	23,8	14,0	10,8	10,4	28,6	20,0	3,2	41,2	442	360,000

(f)- Fire lit

With the open hearth lit the indoor dry-bulb temperature is 4°C higher than the external temperature (Table 6) but is not in the comfort zone, unlike the black globe temperature which is. The radiant surface temperatures are close to the dry-bulb temperature except for the west wall which is close to the open fire and the ceiling. Concentration of ultra-fine particulate matter is high.

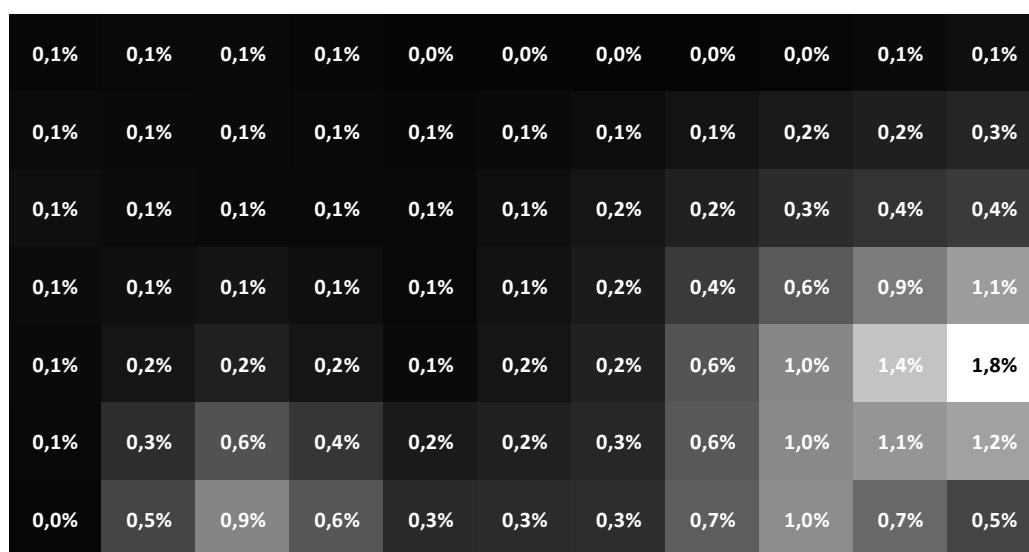

Figure 24: Distribution of daylight factor within the fogón of Don Crescencio 25 July 2014

The natural daylight (Fig.24) is principally concentrated around the doorway which in the case of this *fogón* does not correspond with the area of principal occupation around the open hearth.

3.2.2.2 Continual Measurements: *Fogón* of Don Crescencio

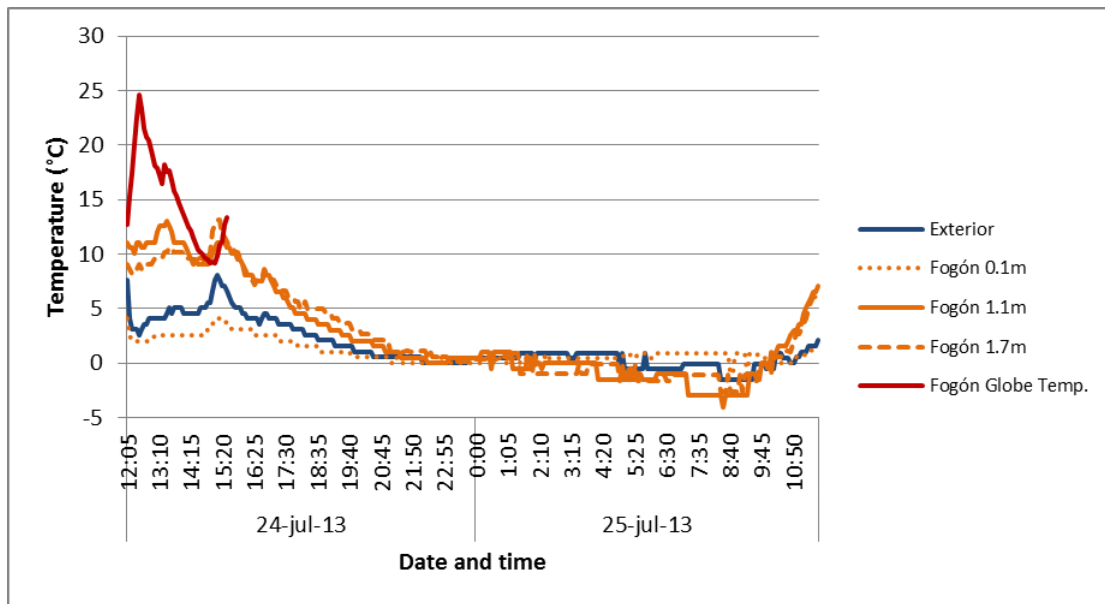

Figure 25: Simultaneous measurements of dry-bulb temperature and globe temperature at different heights. *Fogón* of Don Crescencio 24th-25st July 2013 (Winter)

As with the *rukas* Lafkenche the measurements (Fig.25) show a comfortable globe temperature whilst the hearth is lit, however the dry-bulb temperatures are low and the temperature at 0.1m above floor level is lower than external temperature during the day due to the influence of the high thermal mass of the earthen floor. This thermal mass has a positive influence in the early morning when the temperature at 0.1m remains above 0°C; however the influence is limited and the temperature at 1.1m drops to -4°C, even lower than the external temperature.

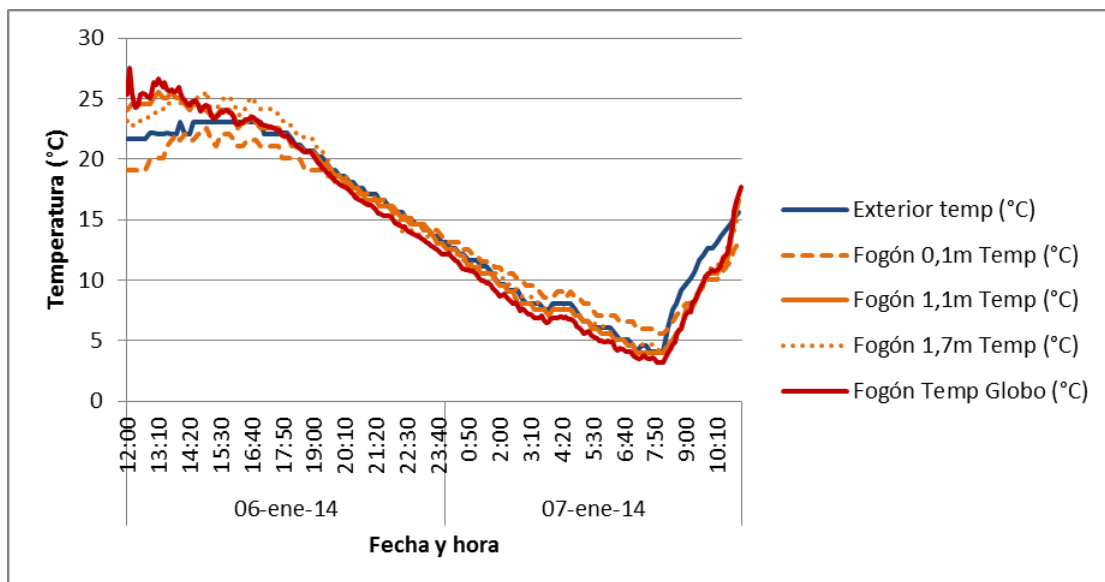

Figure 26: Simultaneous measurements of dry-bulb temperature and globe temperature at different heights. *Fogón* of Don Crescencio 6th-7st January 2014 (Austral Summer)

The influence of the thermal mass of the earthen floor can also be seen in the summer measurements (Fig.26) where the dry-bulb temperature at 0.1m above floor level is lower during the day and higher during the early morning before dawn. Unlike the winter temperatures, the globe temperature is comparable with the dry-bulb temperature even when the open hearth is lit.

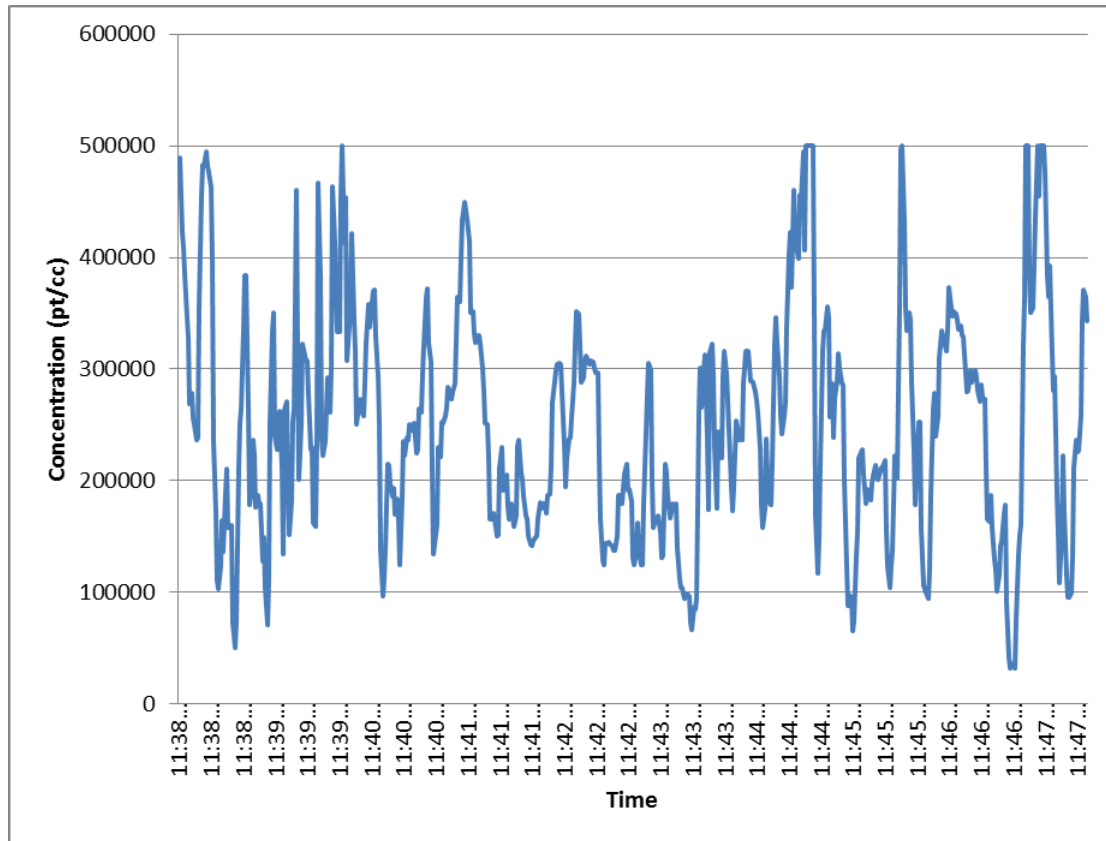

Figure 27: Measurements of concentration of ultra fine particulate matter in the *fogón* of Don Crescencio 25th July 2013 (Austral Winter) with open hearth lit.

As with the Lafkenche *rukás* the concentrations of ultrafine particulate matter is high (fig.27), in some cases exceeding the limit of the measurement instrument (500.000pt/cc.).

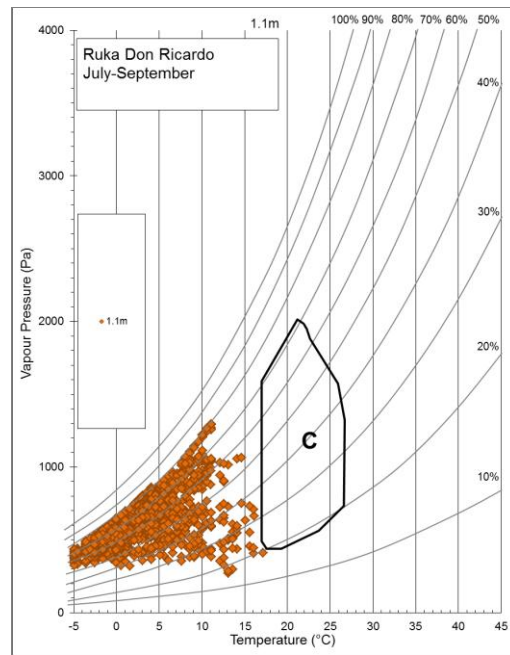
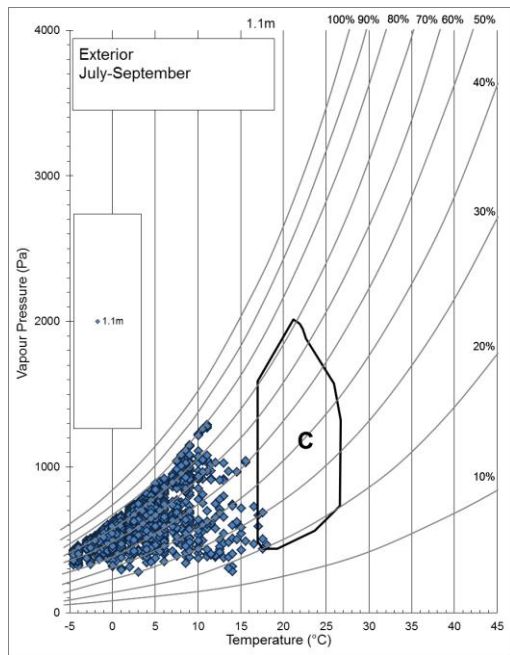

Figure 28 & Figure 29: Psychrometric charts showing temperature and relative humidity of the air externally and in the *fogón* of Don Crescencio from July - September 2013

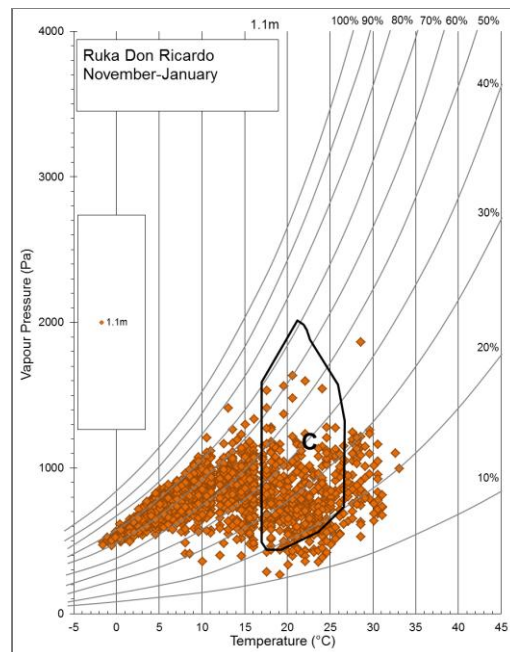
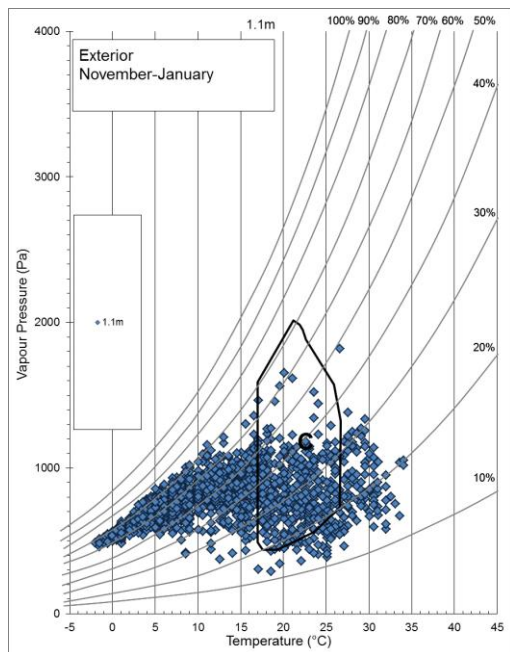

Figure 30 & Figure 31: Psychrometric charts showing temperature and Relative humidity of the air externally and in the *fogón* of Don Crescencio from November 2013 - January 2014

During winter month the results show (Figs. 28&29) that the *fogón* rarely achieves hygrothermic comfort (Givoni 1998) neither does the *fogón* provide the protection against the lowest temperatures provided by the Lafkenche *rukas*. It should however be noted that the external temperatures are more extreme than those of the coast dropping to -7.5°C . The interior temperatures are however more favourable than external conditions with twice as much of the time registering temperatures greater than 10°C . During autumn and early summer (Figs. 30&31) 25% of the measurements both external and internal fall within the higrathermal comfort zone. There is the

occasional occurrence of overheating in the *fogón* with 4% of measurements marking more than 27°C; only 2% of external measurements exceed this temperature.

Results: *Ruka* of Sr. Ricardo Meliñir

Don Ricardo is around 60 years old. The *ruka* that he owns (Figs. 32&33) was constructed 7 or 8 years ago to receive visitors. The construction used no power tools using only axes and *corvinas*, two handled saws. The main roof beams are made from fallen araucaria (*Araucaria araucana*) whilst the cladding is of lenga beech (*Nothofagus pumilio*). Don Ricardo confirmed that with a lot of firewood burning it is cosy, although currently they only use the *ruka* when groups of visitors come to Quinquén. The *ruka* is approximately three times the size of the *fogón* of Don Crescencio and unlike the *fogón* has two windows with timber shutters to close them.

Specific in situ measurements in winter showed internal temperatures fractionally below external conditions.



Figure 32: Author and Sr. Ricardo Meliñir outside the *ruka*. Figure 33: Detail of window and roof.

4 Conclusion

The study of the architecture and construction techniques of the Lafkenche and Pehuenche peoples clearly demonstrates differences due to the materials locally available and adaptation to climatic conditions, however both share elements and concepts united by the world outlook of the Mapuche. For example, both have the same orientation with their main entrance facing east, towards the sunrise, to receive the first energy of the day. Both have the open fire as the focal point of daily life and social contact. Also although they use different materials, in both cases they are natural, local and biodegradable, returning in time to the earth. This ephemeral aspect of Mapuche architecture can be considered highly sustainable and low carbon.

The results of the in situ specific and continual measurements show that, when lit, the open hearths achieve a comfortable globe temperature for those close to the fire; however they have little effect on the dry-bulb temperature. It is therefore necessary for the inhabitants to draw close to the hearth to appreciate its warmth. This necessity is prized by the inhabitants, seen as a positive aspect that unites the family and strengthens the bonds and relationship between them. The natural daylighting in the Lafkenche *ruka* is also focused on the area around the hearth, close to the door, reinforcing the importance of this space for daily activities. The interviews corroborate that shown by the results of the globe temperature measurements, that around the fire thermal comfort is achieved in winter. The interviews indicated that in

summer the internal temperatures of the *rukas* are more comfortable than the modern houses; however this perception was not conclusively confirmed by the in situ specific measurements of dry-bulb temperature and superficial radiant temperature but continual summer measurements did identify some overheating of the timber cabin. It is important to note that more than one of the interviewees commented that the modern *rukas* are not as well insulated as those built previously. This obviously has an impact on the measurements.

It is however the concentration of ultra-fine particles arising from the open hearth that poses the greatest challenge of achieving environmental comfort in this indigenous architecture. The open, flueless hearth is an important source of heat and communion, yet its negative impact on air quality is notable.

The lessons we can learn from the architecture Lafkenche and Pehuenche do not lead to a simple affirmation that they are examples of sustainable architecture. Their deficits in environmental comfort signify that a direct application of the traditional technologies is not appropriate for modern habitation. However their use of local, low energy, natural materials is highly commendable and it is this aspect which presents an opportunity which could be developed in the search for a new sustainable architecture appropriate to the Araucania Region.

References

Arboleda, G., 2006. *What is Vernacular Architecture? Ethno Architecture* [online] PhD Program in Architecture, College of Environmental Design, University of California at Berkley. Available from: <http://www.vernaculararchitecture.com/> [2 October 2012]

Bertin, X., 2012. 'Turismo patrimonial atrae al 40% de visitantes extranjeros', *La Tercera*, 3 October 2012, pp 10.

CEN (Comité Europeo de Normalización) 2002. *Ergonomics of the thermal environment - Instruments for measuring physical quantities*. ISO 7726:1998, Madrid: AENOR.

Coña, P., 2002. *Lonco Pascual Coña ñi tuculpazugun/ Testimonio de un cacique mapuche*. 7th ed, Santiago: Pehuén. pp. 185-198 (chapter X) (First published as de Moesbach, E. W., 1930, *Vida y costumbres de los indígenas araucanos en la segunda mitad del siglo XIX*, Santiago: Imprenta Cervantes, pp. 170-183)

Cook, J., 1996. Architecture Indigenous to Extreme Climates. *Energy and Buildings*. 23 pp 277-291.

Dirección de Aguas 2012, *Meteorological Data Liucura*, Santiago de Chile: Ministerio de Obras.

Foruzanmehr, A. & Vellinga, M., 2011. Vernacular Architecture: Questions of Comfort and Practicability. *Building Research & Information*, 39(3), pp 274-285.

Gross, P., 1978. *Arquitectura en Chile*, Santiago de Chile: Ministerio de Educación.

Givoni, B., 1998), *Climate Considerations in Building and Urban Design*, New York: Van Nostrand Reinhold.

Huang, L & Lui, F (2010) Thermal Analysis of Tibetan Vernacular Building- Case of Lhasa. *World Academy of Science, Engineering and Technology*. 68 pp 1458-1462.

INN (Instituto Nacional de Normalización) 2008. *NCh 1079. Of 2008 Zonificación climática habitacional para Chile y recomendaciones para el diseño arquitectónico*. Santiago de Chile: INN.

MOP (Ministerio de Obras Públicas) 2003. *Guía de Diseño Arquitectónico Mapuche para edificios y espacios públicos*, Santiago de Chile.

Oliver, P., 1969. *Shelter and Society*, New York: F. A. Praeger.

Otero, L., 2006. *La huella del fuego: historia de los bosques nativos. Poblamiento y cambio en el paisaje del sur de Chile*. Santiago de Chile: Pehuén. pp 40.

Rapoport, A., 1969 *House Form and Culture*. NJ, USA: Prentice Hall Inc.

Rapoport, A., 2006. *Vernacular Design as a Model System in Vernacular Architecture in the Twenty-First Century: Theory Education and Practice*, eds Asquith L. and Vellinga M. London: Taylor & Francis.

Rudofsky, B., 1968. *Architecture without Architects: A Short Introduction to Non-Pedigreed Architecture*. New York: MOMA.

Sernatur 2012. *La Ruca mapuche, ícono de promoción internacional de La Araucanía, Pymesur* [Online], Available: <http://www.pymesur.cl/araucania/la-ruca-mapuche-icono-de-promocion-internacional-de-la-araucania.html> [6 October 2012]

Ubbelohde, S., 1991. The Myth of the Ecological Vernacular. *Design Book Review*. 20, pp 27-29.

Uribe J.M., Cabrera R., de la Fuente, A., & Paneque, M., 2012. *Atlas Bioclimático de Chile*. Santiago de Chile: Universidad de Chile.

Wainsberg I.M., 1978. *En Torno a la Historia de la Arquitecura Chilena*, Santiago de Chile: publicación DAU, serie estudios N°2.

Zhai, Z., & Previtali, J., 2009. Ancient Vernacular Architecture: Characteristics Categorization and Energy Performance Evaluation. *Energy and Buildings*, 42, pp.357-365 .

Simulating the human-building interaction: Development and validation of an agent-based model of office occupant behaviours.

Jared Langevin¹, Jin Wen¹, and Patrick L. Gurian¹

¹ Department of Civil, Architectural, and Environmental Engineering, Drexel University, Philadelphia, PA, USA, jared.langevin@gmail.com;

Abstract

This paper develops and validates an agent-based model (ABM) of occupant behaviour using data from a one-year field study in a mid-sized, air-conditioned office building. The full ABM is presented in detail using a standard protocol for describing this type of model. Validation of the ABM assigns simulated occupant “agents” the personal characteristics and environmental context of real office occupants in the field study; executes the model; and compares the model’s ability to predict observed fan, heater, and window use to the predictive abilities of several other behaviour modelling options. The predictive performance of the full ABM compares favourably to that of the other modelling options on both the individual and aggregate outcome levels. The full ABM also appears capable of reproducing more familiar regression relationships between behaviour and the local thermal environment.

Keywords: Occupant behaviour simulation; agent-based modelling; thermal comfort; thermal acceptability

1 Introduction

Long-term field observations of building occupants broadly support Humphrey’s hypothesis that *“If a change in the thermal environment occurs, such as to produce discomfort, people react in ways which tend to restore their comfort”* (Humphreys, 1997). Indeed, occupant adaptations are seen to contribute to both thermal comfort and energy use outcomes, whether measured or simulated (Stemers et al, 2009; Hong, 2013).

To account for occupants’ adaptive behaviours as part of the building design and operation processes, several behaviour models have been developed over the last decade for integration with whole building energy simulations. The most prominent of these models are of the statistical type, describing the group-level probability of a given behaviour in terms of thermal stimuli like indoor and outdoor temperature (Nicol, 2001). The models are commonly calibrated to data from cellular offices in naturally ventilated buildings in Europe, and focus most often on window opening behaviour.

Examples of existing statistical models are found in the study of Nicol (2001), which introduces the concept of simulating multiple behaviours stochastically using generalized linear models; the study of Rijal et al (2007a), which calculates the probability of a window opening in terms of operative indoor and outdoor air temperatures after a +/-2K deadband around “comfort temperature” has been breached (the “Humphreys algorithm”), and which also suggests the incorporation of “active” and “passive” window users; the study of Yun and Stemers (2008), which fits sub-models of window opening probability for occupant arrival,

intermediate, and departure periods, with indoor temperature and previous window state as predictor variables; and the studies of Haldi and Robinson (2008, 2009), in which the authors find occupant behaviour to be better described by internal than external temperature, and develop sub-models for window opening probability for arrival, intermediate, and departure times using Markov chains coupled with survival analysis.

In general, the above models have the advantage of being simple to communicate and implement as part of building simulation routines. However, some issues arise with their use:

- The models only roughly account for inter-individual variability in behaviour through the definition of “active” and “passive” occupant groups.
- The models do not simulate multiple behaviours together or addresses behavioural sequencing.
- The models do not account for social influences/other constraints on behaviour in non-private offices.
- Few models address the most immediate adaptive opportunities (clothing, personal fans/heaters) despite the substantial use of these behaviours when available (IFMA, 2009).
- The extensibility of these models to air-conditioned buildings in climates with greater seasonal variability is not well established.

It has recently been suggested that some of the above points could be addressed by the development of Agent-Based Models (ABMs) of occupant behaviour (Robinson et al, 2011). ABMs represent individuals as autonomous “agents” with personal attributes and behavioural possibilities, as well as rules for interacting with other agents and their surrounding environment (Macal and North, 2010); group-level behaviours then emerge from the adaptive behaviours of individual agents. In the context of building occupant behaviour, ABMs continue a conceptual progression of existing modelling approaches as shown in Figure 1.

Only a few existing studies have yet attempted to develop ABMs of building occupants’ behavioural adaptations. This includes the study of Andrews et al (2011), which couples an ABM of daily occupant lighting use with the RADIANCE software, and the study of Azar and Menassa (2010), which models interactions between occupant agents of different energy consumption habits as they relate to whole building energy use. These studies suggest that individual-level behaviour routines can be successfully incorporated into whole building energy simulation; however, they reveal two significant shortcomings:

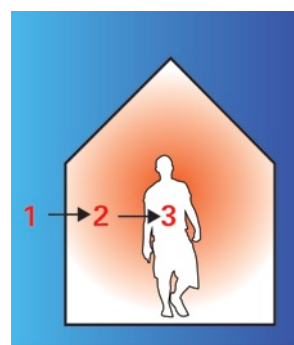

- 1 Climate - Level**
Nicol (2001)
Behaviour driven by outdoor temperature.
- 2 Building - Level**
Rijal et al (2007), Yun and Steemers (2008),
Haldi and Robinson (2009)
Behaviour driven by indoor & outdoor temperature.
- 3 Occupant - Level**
Agent-Based Model (current paper)
Behaviour driven by personal thermal comfort.

Figure 1 Conceptual progression in behaviour modelling approaches.

1. ABM descriptions are not presented in a standard manner that is clear and complete. Key details about the modelling assumptions, source of agent behaviour rules, etc. are often missing, making it difficult for other researchers to interpret, reproduce, and build upon the given model.

2. A general approach to ABM validation is not provided; the studies do not validate developed models against long-term field data on behaviour.

With these shortcomings in mind, this paper seeks to report the development and validation of a novel, agent-based model of thermally adaptive office occupant behaviour in a way that is legible to other researchers and useful to future behaviour model-building efforts. In support of this goal, the developed ABM is described using a standard protocol. The model addresses personal factors towards behavioural outcomes; considers a full range of behavioural opportunities and their sequencing; and simulates behaviour in both private and non-private offices. Simulated agent behaviours are validated against behaviour data from a one-year field study, and the predictive performance of the full ABM is compared to that of multiple other behaviour modelling approaches.

2 Methods

2.1 Field Study

Data used to develop and validate the full ABM of this paper were collected between July 2012 and July 2013 in the Friends Center, a medium-sized office building in downtown Philadelphia, USA. Key aspects of the Friends Center study are outlined as follows¹:

- **Subject Sample.** From an initial sample of 45 occupants who completed a background survey link, a final sample of 24 occupants was selected for participation in the full study. The final sample includes occupants of all office types (private/semi-private/open), from all floors of the building, with varying control opportunities that include the use of windows (N=10) and personal heaters/fans (N=4 and N=5, respectively).
- **Daily Surveys.** For two weeks in each season, the occupant sample completed an online survey three times daily (shortly after arrival; late morning; late afternoon). The survey included questions about recent occupancy; work flow/productivity; thermal comfort; thermal sensation, acceptability, and preference; and recent behavioural opportunities and actions. At the end of two weeks, a final retrospective survey asked about occupancy, thermal comfort, and behaviour over the past two weeks of surveying.
- **Environmental Measurements.** Across the full year of the study, dataloggers measured the local thermal environment continuously. Local ambient temperature was logged for all occupants, either through HOBO loggers at their desks (5 min. interval) or through nearby thermostat readings (15 min. interval). Relative humidity was measured at the desks of half the occupant sample (5 min.); globe temperature was measured at one perimeter and core desk on each floor (5 min.); and air velocity was measured at one desk on each floor (5 min.).
- **Behaviour Measurements.** Personal fan and heater use were logged at 15-minute intervals using WattsUp? power meters. Window use was monitored using HOBO state loggers.

2.2 Modelling Approach

¹ The reader is referred to Langevin et al (2013a) for more details about the longitudinal study methods.

This study approaches the behaviours of occupant agents through the theoretical lens of Perceptual Control Theory (PCT)², which states “behaviour is the control of perception” (Powers, 1973). Under PCT, behaviour is not regarded as the response to a catalysing stimulus, but as the by-product of a negative feedback loop in which an organism acts to bring some perceived state of the world into line with a reference perception, despite environmental disturbances.

Figure 2 presents the general PCT schematic and suggests how each of its items can be translated to an agent-based simulation of building occupant behaviour. Here, thermal

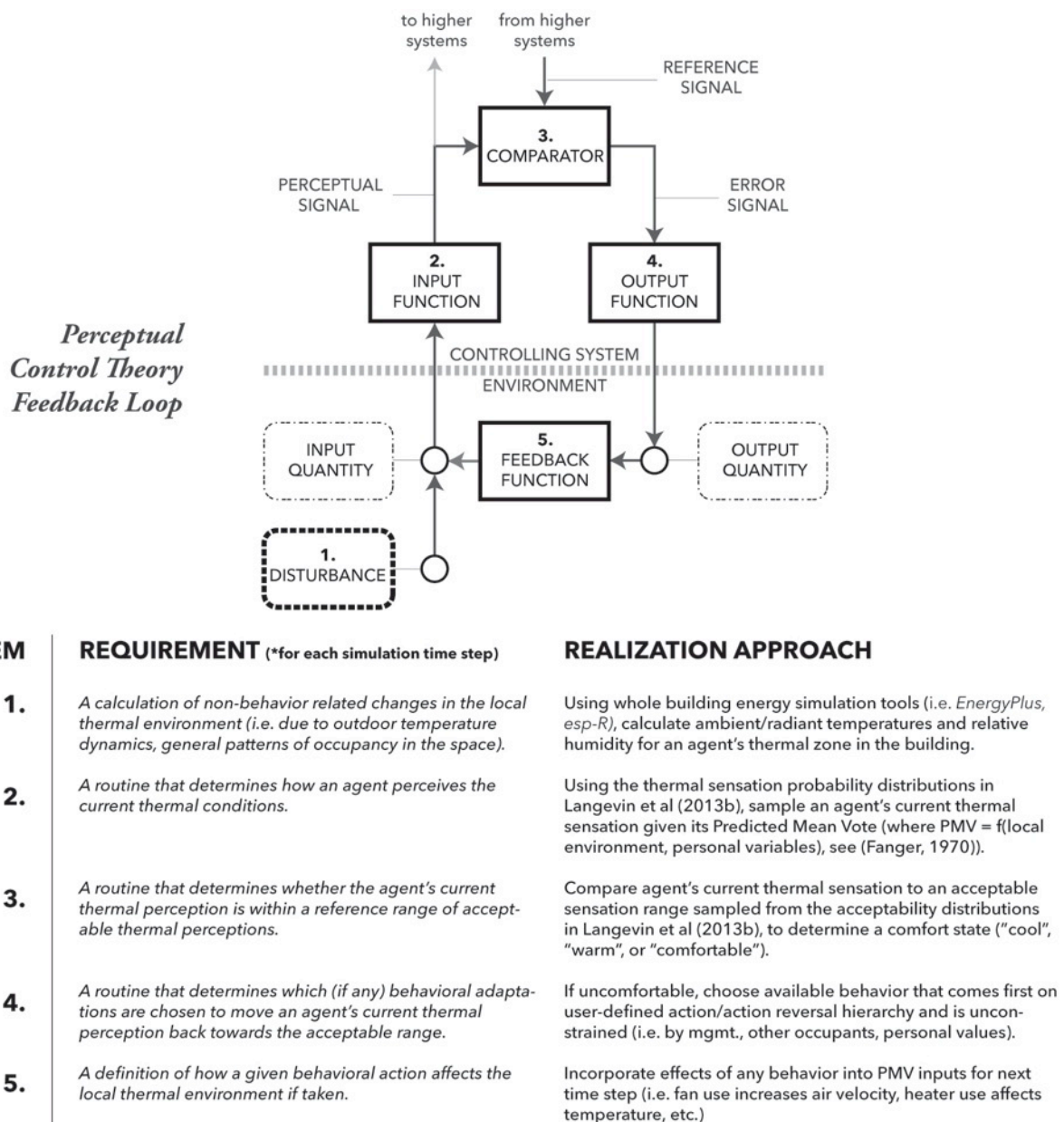

Figure 2 Perceptual Control Theory schematic as it relates to simulation of the thermally adaptive behaviours of building occupants.

² Perceptual Control Theory is also referenced in Schweiker et al (2009) as a potential theoretical basis for occupant behaviour models, and is implicit in the Humphrey's algorithm (Rijal et al, 2007a).

sensation is treated as the perception under control in the PCT framework; behaviour is then required when one's thermal perception is outside of a reference thermal acceptability range, with "warm" behaviour required when the occupant's current sensation is above his or her *maximum* acceptable sensation, and "cold" behaviour required when a current sensation is below the occupant's *minimum* acceptable sensation. The behavioural option chosen to manage these cases of discomfort is conceived of as that which is most immediately accessible and unconstrained (i.e. by management, others in the space, personal values).

To facilitate interpretation of this general approach to behaviour modelling, a detailed description of the full ABM it anchors is provided in the Results section using the ODD protocol (Overview, Design concepts, and Details), devised by Grimm et al (2010) to standardize published descriptions of ABMs.

2.3 Model Validation Procedure

Validation of the full ABM involves assigning simulated agents the personal and environmental characteristics of real occupants in the Friends Center field study; executing the ABM; and comparing simulated agent behaviours against measured behaviours for the field occupant during the simulated time period. The validation procedure focuses on personal fan, heater, and window use because high-resolution measurements are available for these behaviours across the longitudinal study period. For each season of the study, at least one week of these measurements was selected for validation purposes, during times when corresponding occupancy information was available from daily survey responses. In total, a single simulation run encompasses four and a half work weeks:

- August 6th – August 10th, 2012
- October 31st – November 9th, 2012
- February 4th – February 8th, 2013
- April 15th – April 19th, 2013

Because the full ABM includes stochastic elements, its predictive performance is evaluated after 20 repeated simulations of the above time periods. Drawing from the validation approach of Haldi and Robinson (2009), predictive performance is assessed on the level of both individual and aggregate outcomes. At the individual outcome level, each simulated outcome is classified as either: a truly positive outcome (TP); a falsely positive outcome (FP); a truly negative outcome (TN); or a falsely negative outcome (FN). From these classifications, the following metrics are calculated:

- **True Positive Rate (TPR)** = $TP / (TP + FN)$;
- **False Positive Rate (FPR)** = $FP / (FP + TN)$;
- **Specificity (SPC)** = $1 - FPR$
- **Balanced Accuracy (BA)** = $(TPR + SPC) / 2$

The model's True Positive Rate can be plotted against its False Positive Rate in the Receiver-Operating Characteristic (ROC) space (Metz, 1978) to yield a graphical assessment of how well it predicts individual outcomes compared to an ideal model (TPR = 1; FPR = 0).

On the level of aggregate behaviour outcomes, simulated and observed daily trends in group-level behaviour frequencies are plotted by season and compared qualitatively.³ Quantitative assessment of aggregate predictive performance then calculates the coefficient of

³ Mean daily behaviour frequencies are calculated for each season by averaging the total number of occupants using a given behaviour at each time step across all the time steps simulated for that season.

determination (R^2) and Root Mean Square Error (RMSE) between simulated and observed aggregate behaviour outcomes at each time step (see Montgomery et al, 2008).

A final, qualitative measure of the full ABM's predictive performance examines its ability to reproduce *stylized facts*, described by Rand (2011) as “general concepts of a complex system derived from the knowledge of subject matter experts”. Stylized facts for the three behaviours examined can be stated as follows:

- **Personal fan** and **window** use probability *increases* as indoor temperature *increases*.
- **Personal heater** use probability *decreases* as indoor temperature *increases*.

These baseline trends can be verified with the Friends Center validation data by regressing observed behaviour states on corresponding measurements of indoor operative temperature.

To place validation of the full ABM into context, the predictive performances of several alternative behaviour modelling approaches are also evaluated as above and compared to that of the full ABM approach. The full set of modelling options follows:

1. **Random Guess.** Agent behaviour is determined by a coin toss.
2. **Logistic Regression (Aggregate).** Agent behaviour is determined by a logistic regression model, fit to *group-level behaviour data* collected in the Friends Center during the periods of daily surveying.
3. **Logistic Regression (Individual).** Same as # 2, but with logistic regressions fit to behaviour data for *each individual occupant separately*.
4. **Humphreys Algorithm.** Agent behaviour is determined using the group-level regression fit in #2 in the Humphreys behaviour algorithm (Rijal 2007).⁴
5. **Haldi Regressions.** Agent behaviour is determined by group-level logistic regressions fit in Haldi et al (2008) for naturally ventilated buildings (only fans and windows).
6. **ABM (Standard Acceptability).** Agent behaviour is determined as in Figure 2, but agents are all assigned the standard thermal acceptability range (-1 (“Slightly Cool”) to +1 (“Slightly Warm”)).
7. **ABM (Standard Clo/Met).** Agent behaviour is determined as in Figure 2, but agents cannot modify clothing from seasonal standards (0.5 Clo spring/summer; 1.0 Clo fall/winter), and have constant standard Met of 1.1 (i.e., based on ASHRAE Std. 55 Clo/Met assumptions (ASHRAE, 2010)).
8. **ABM (Full).** Agent behaviour is determined as in Figure 2, agents freely adjust clothing, and Met levels change based on daily occupancy dynamics.

Each of the modelling options is simulated in Matlab, with individual agents and agent groupings implemented using Structure Arrays.

3 Results

3.1 Key Field Observations

⁴ The algorithm checks whether current operative temperature is within 2K of the comfort temperature (see CEN (2007)); if outside this 2K deadband, warm/cool behaviour is predicted probabilistically using a logistic regression equation with operative indoor temperature and outdoor temperature as predictors.

Development of the full ABM described in section 3.2 below is based on the results of the Friends Center field study as well as relevant findings from the existing behaviour literature. Field observations with the greatest significance to model construction are summarized as follows:

- ***Thermal acceptability and comfort:*** Normalizing an occupant's thermal sensation to his or her personal range of acceptable sensations may effectively account for inter-individual variations in thermal comfort and associated adaptive behaviours. In the Friends Center study, there is a significant negative correlation between thermal comfort votes and the degree to which occupants' sensations fall outside their reported acceptable ranges ($\rho=-0.66$ vs. $\rho=-0.44$ if a standard acceptable range ("Sl. Cool" to "Sl. Warm") is assumed, p value of difference < 0.001).⁵ Occupants' thermal acceptability ranges change most significantly on a seasonal basis - particularly at the cold extreme.
- ***Behavioural preference and sequencing:*** Friends Center occupants tend to exercise the most immediate thermal adaptations with some regularity when available (clothing; fans; heaters), and less immediate adaptations infrequently (thermostats; windows; blinds).⁶ Datalogger information shows that personal heaters tend to be turned on first in late morning (around 10:30 AM), in contrast to first use of fans and windows, which peaks in the early morning (8:30 – 9:30 AM). Window use rarely occurs before a fan adjustment for the limited number of Friends Center occupants with both these control options (5% of the time).⁷
- ***Behavioural constraints:*** Occupants generally do not wear clothing less than 0.3 Clo or greater than 1.3 Clo. For window use, a small peak is seen at an outdoor temperature around 24°C, suggesting that occupants constrain window opening when warmer outdoor air is anticipated to make discomfort worse.⁸ In the Friends Center background survey, several occupants indicate certain available controls are not allowed, or that use of some controls must be checked with others; these responses suggest contextual constraints on behaviour.
- ***The role of clothing and activity level:*** Clothing change is significant for Friends Center occupants both within and between days, but is more prevalent for the latter (about 50% of the time between days vs. about 20% within a day).⁹ Activity levels are significantly higher on occupants' morning surveys due to each occupant's preceding morning commute. This condition possibly explains the peak in first fan and window usage upon arrival (the occupant is warm), as well as the lag in first heater usage (the occupant cools off by late morning).

The following section details the agent-based occupant behaviour model that was developed from the above observations.

⁵ Humphreys et al (2007) similarly suggest the possibility of normalizing thermal sensations to personal preferences in the description of thermal comfort.

⁶ Consistent with findings for air-conditioned buildings in (IFMA, 2009). Doors and drinks are both used significantly, but occupants frequently indicate non-thermal reasons for these behaviours.

⁷ This suggests a different control sequencing in air-conditioned vs. naturally ventilated buildings, where window use has been suggested to occur before the use of fans (Rijal et al, 2008; Haldi et al, 2009)

⁸ As suggested in previous naturally ventilated building studies (i.e. Rijal et al (2008); Haldi et al (2008)).

⁹ Consistent with previous findings in Haldi et al (2008b).

3.2 ODD Outline of Full Agent-Based Model

1) **Purpose:** The model is used to predict the thermal comfort and related adaptive behaviours of individual office building occupants over time, from which zone-level behaviour trends can be constructed for use in whole building energy simulation. The current model implementation considers the following thermally adaptive behaviours:

- a) Clothing adjustment
- b) Personal fans on/off
- c) Personal heaters on/off
- d) Thermostat up/middle/down
- e) Windows open/closed

Note: occupant use of warm/cool drinks, doors, lights and blinds are not currently implemented under the assumption that these behaviours are not primarily thermally driven.

2) **Entities, state variables, and scale:** See Figure 3 for an outline of entities and state variables. The scale of the model is a single office building, with no further spatial resolution. One time step in the model currently represents fifteen minutes; it is generally expected that users would simulate a full period of one year or less.



<i>Entity</i>	<i>State Variables</i>	
 Occupant Agents	Number ID, office type & location Occupancy (Baseline arrival/lunch/departure times; probability of leaving for lunch; probability of hourly walkabout) Commuting method (Bike; Walk; Bus; Car) Personal traits (Listens to management; Considers others' comfort; Prioritizes work flow over comfort; Doesn't understand controls; Cares about personal energy use) Shared behavioural control IDs Thermal acceptability range (ASHRAE Sensation Scale) Morning clothing level (Clo upon first sitting down) Current clothing level (Clo) Current activity level (Met) Current behavioural opportunities Current behavioural states	} Constant } Changes Seasonally } Changes Daily } Changes @ Timestep
 Local thermal environment	Outdoor Running Mean Temp (°C) Ambient Indoor/Outdoor Temperature (°C) Indoor & Outdoor Relative Humidity (%) Air Velocity (m/s) Mean Radiant Temperature (°C)	} Changes Daily } Changes @ Timestep
 Agent Collectives	Collective # 1 Office Types Number ID Max # occupants per office Office-level behavioural constraints <hr/> Collective # 2 Thermal Zones Number ID # each office type in zone Zone-level behavioural constraints	} Constant

Figure 3 Outline of entities and state variables in the full ABM.

3) **Process overview and scheduling:** see Figure 4.

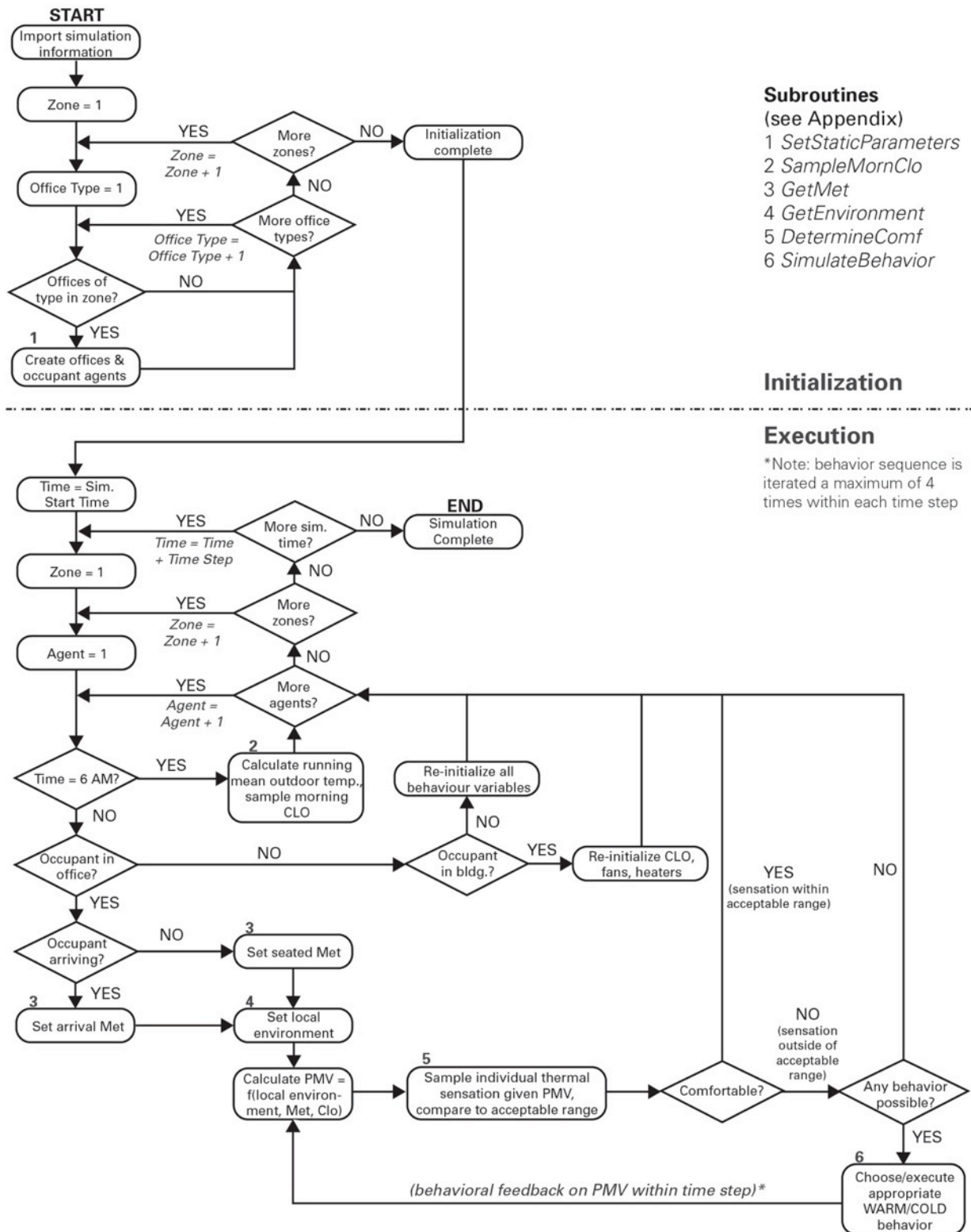

Figure 4 Simulation process flow chart. Sub-routines of various process elements are numbered on the chart, with their names given at top right - each sub-routine is further detailed in the Appendix.

4) Design Elements

- a. **Basic Principles:** Agent behaviour in the model is founded on Perceptual Control Theory (PCT), with thermal sensation as the perception under control in the PCT framework, as described in the Methods.
- b. **Emergence:** Both the thermal comfort and behaviour of agents in the model constitute emergent outcomes, varying in complex ways according to the dynamics of one's local thermal environment, occupancy patterns, and the acceptability of various thermal sensations in each season.
- c. **Adaptation:** Agents adapt aspects of their thermal environment and clothing in order to maintain a thermal sensation that is within a reference acceptable range. For each time step that the agent's sensation is outside of this reference range (representing discomfort), the agent chooses and executes an adaptive action, monitors the feedback of the action on its comfort level, and acts again if still uncomfortable. Currently, this process is iterated up to four times per time step.
- d. **Objectives:** The agents' primary objective is to keep its thermal sensation within a personally acceptable range of sensations. In choosing behavioural actions to meet this objective, the agent adheres to a user-defined hierarchy of adaptive possibilities and constraints. In the current modelling setup, the agent checks to see if previous adaptations can be reversed; if not, the agent chooses the most immediate and unconstrained adaptations first (clothing, then fans/heaters) and moves on to less immediate options if still uncomfortable (thermostats, windows). Current constraints on behaviour come from its state (i.e. reasonable clothing limits) as well as its context (i.e. management, social influences).
- e. **Learning:** Agents in the model do not currently change adaptive traits over time through learning.
- f. **Prediction:** Agents do not open windows when the action is predicted to make warm discomfort worse (in the simulation, when the daily outdoor running mean temperature (CIBSE, 2006) is greater than the indoor operative temperature).
- g. **Sensing:** Agents translate information about their local thermal environment and personal characteristics into a thermal sensation using the Predicted Mean Vote (PMV) model (Fanger, 1970), which calculates a group-level thermal sensation as a function of *ambient air temperature, relative humidity, air velocity, mean radiant temperature, clothing level, and metabolic rate*. Here, the group-level PMV outcome is translated to an individual thermal sensation using the sensation distributions developed in Langevin et al (2013b). The agent's individual sensation is then compared to its acceptable sensation range to determine behavioural outcomes, as described above.
- h. **Interaction:** Agents in shared private offices and in open offices may have user-defined social constraints on certain behaviours. When considering a socially constrained behaviour, the agent checks whether use of the given control leads to discomfort for greater than 50% of the other agents sharing it (control sharing is set at the beginning of the simulation). If so, the behaviour is removed as an option for that time step.
- i. **Stochasticity:** During model initialization, an agent's commuting type, personal traits, occupancy, thermal acceptability ranges (warm/cool seasons), and initial morning clothing level are modelled stochastically, as indicated in Table 1 below. During the simulation run period, an agent's thermal sensations are modelled stochastically. The reader is referred to the Appendix for details about relevant simulation subroutines.

- j. **Collectives:** Collectives include agent office types and thermal zones, as was outlined earlier in section 3.2.2. An agent’s behavioural opportunities and associated contextual constraints are initialized based on the type of office and zone it occupies.
- k. **Observation:** For model verification, individual agents and their state variables were tracked at each time step to ensure that the variables were changing in an expected way, and that the processes determining agent comfort and behaviour were running as intended. For model validation, at each time step: simulated and observed individual behaviour states were tracked for use in calculating model predictive metrics (accuracy, true positives, etc.); group-level behaviour statistics were calculated for use in time series plots; and simulated and observed individual behaviour outcomes were tracked alongside corresponding indoor and outdoor temperatures, for use in stylized facts plots.

5) **Initialization:** Users define the number of occupants per each of nine office types and the number of each office type per zone. The user can also impose any office or zone-level behavioural constraints (default values are otherwise provided). Together, this information guides the agent initialization process, as diagrammed earlier in Figure 4. In Table 1, details are provided about the initialization of an agent’s state variables.

Table 1 Initialization of agent state variables

State Variable	Initial Value*
Number ID	Assigned as agent is created
Office type	""
Office location	""
Typical occupancy information	Sampled from user-defined occupancy schedules/parameters
Commuting method	Sampled from on user-defined commuter distribution
Personal traits	Sampled from user-defined personal traits distribution
Thermal acceptability ranges	Two ranges sampled (warm/cool seasons) from thermal acceptability probability distributions in Langevin et al (2013b)
Morning clothing level	Sampled from user-defined morning clothing lognormal distribution for starting season of simulation (constrained to $0.3 \leq Clo \leq 1.3$)
Current clothing level	Set to morning clothing level
Current activity level	Set based on commute method, using ASH Std. 55 (2010) Met values
Current behaviour opportunities	Set based on office type & zone restrictions
Current behaviour states	All set to zero (off/closed)

*Default values are provided for user-defined distributions; initial values could also be based upon field survey data for a given building being simulated, if available.

- 6) **External input data:** The model does not require an external input dataset to represent changes in the local thermal environment over time; these changes would be calculated via a coupled whole building energy simulation routine (see Discussion).
- 7) **Subroutines:** see Appendix.

3.3 Model Validation

To validate the above ABM as described in the Methods, an agent’s variables were set to corresponding field measurements for a Friends Center occupant; the model was executed; and the model’s resulting predictive performance was compared to that of several other behaviour modelling options. Agent variables were set to an occupant’s field data as follows:

- **Control availabilities/constraints** were set based on the occupant’s indication of control possibilities on the background survey.
- **Thermal acceptability ranges** were set seasonally based on the acceptability limits most frequently reported by the occupant across the two-week daily surveying run for each season.
- **Daily occupancy** was set based on the arrival/lunch/departure times reported by the occupant, as well as his/her reported periods of significant absence.
- **Morning metabolic rates** were set based on the commute method typically reported by the occupant, with reference to ASHRAE Std. 55 (2010).
- **Morning clothing levels** were set based on the clothing reported by the occupant on the morning survey for each simulated day, (ASHRAE, 2010).
- **Local thermal environment** was updated with the datalogger and/or thermostat measurements for the occupant at every simulation time step.

Table 2 summarizes quantitative validation results for the full ABM and all other modelling options tested; these results are discussed further in the following sub-sections.

Table 2 Summary of individual-level and aggregate-level prediction metrics for all modelling options.

Model	Fans					Heaters					Windows				
	Individual Predictions			Aggregate Predictions		Individual Predictions			Aggregate Predictions		Individual Predictions			Aggregate Predictions	
	TPR	SPC	BA	R ²	RMSE	TPR	SPC	BA	R ²	RMSE	TPR	SPC	BA	R ²	RMSE
Random Guess	0.50	0.50	0.50	0.22	1.01	0.49	0.50	0.50	0.11	0.96	0.51	0.50	0.51	0.04	2.81
Log. Reg. (Agg.)	0.41	0.74	0.57	0.53	0.64	0.27	0.82	0.54	0.20	0.54	0.03	0.98	0.50	0.01	0.62
Log. Reg. (Indiv.)	0.58	0.82	0.70	0.61	0.58	0.46	0.89	0.67	0.38	0.47	0.06	0.98	0.52	0.06	0.60
Humphreys	0.11	0.99	0.55	0.35	1.08	0.38	0.84	0.61	0.08	0.78	0.05	1.00	0.52	0.20	0.59
Haldi	0.09	0.95	0.52	0.16	1.03	--	--	--	--	--	0.40	0.66	0.53	0.01	1.94
ABM (Std. Prefs.)	0.13	0.96	0.54	0.52	0.98	0.09	0.97	0.53	0.36	0.63	0.07	0.93	0.50	0.00	0.73
ABM (Std. Clo/Met)	0.60	0.71	0.65	0.46	0.74	0.67	0.62	0.64	0.26	0.81	0.27	0.77	0.52	0.01	1.57
ABM (Full)	0.57	0.82	0.69	0.61	0.60	0.48	0.85	0.67	0.42	0.46	0.32	0.93	0.62	0.26	0.54

* TPR = True Pos. Rate; SPC = Specificity (1 - False Pos. Rate); BA = Balanced Accuracy ((TPR + SPC)/2); RMSE = Root Mean Sq. Error

3.2.1 Quality of Individual Predictions

Figure 5 plots the outcome of each tested model in the Received Operating Characteristic (ROC) space. From this and the associated “Individual Predictions” statistics in Table 2, it is clear that the full ABM performs favourably relative to the other models tested for all three behaviours considered. For fan use, the full ABM achieves a balanced accuracy close to that for the logistic regression model fit to each individual occupant (69% vs. 70%); for heater and window use, the balanced accuracy of the full ABM is equal to or higher than that of the individually fit logistic regressions (67% vs. 67% and 62% vs. 52%, respectively). The full ABM also performs substantially better than the group-level logistic regression model in all cases.

In the version of the ABM where clothing and metabolic rate are fixed, high true positive rates are achieved for fan and heater prediction, but at the expense of higher false positive rates, indicating that failure to consider realistic occupant clothing and metabolic rate dynamics leads to over-prediction of behavioural interactions. When agents are assigned standard acceptability ranges, the model tends to under-predict behaviour; this is evidenced by the low true and false positive rates yielded by this model.

It is noted that the logistic regression models based on the summer naturally ventilated data of Haldi et al (2008) tend to over-predict window use (high false positive rate), and under-

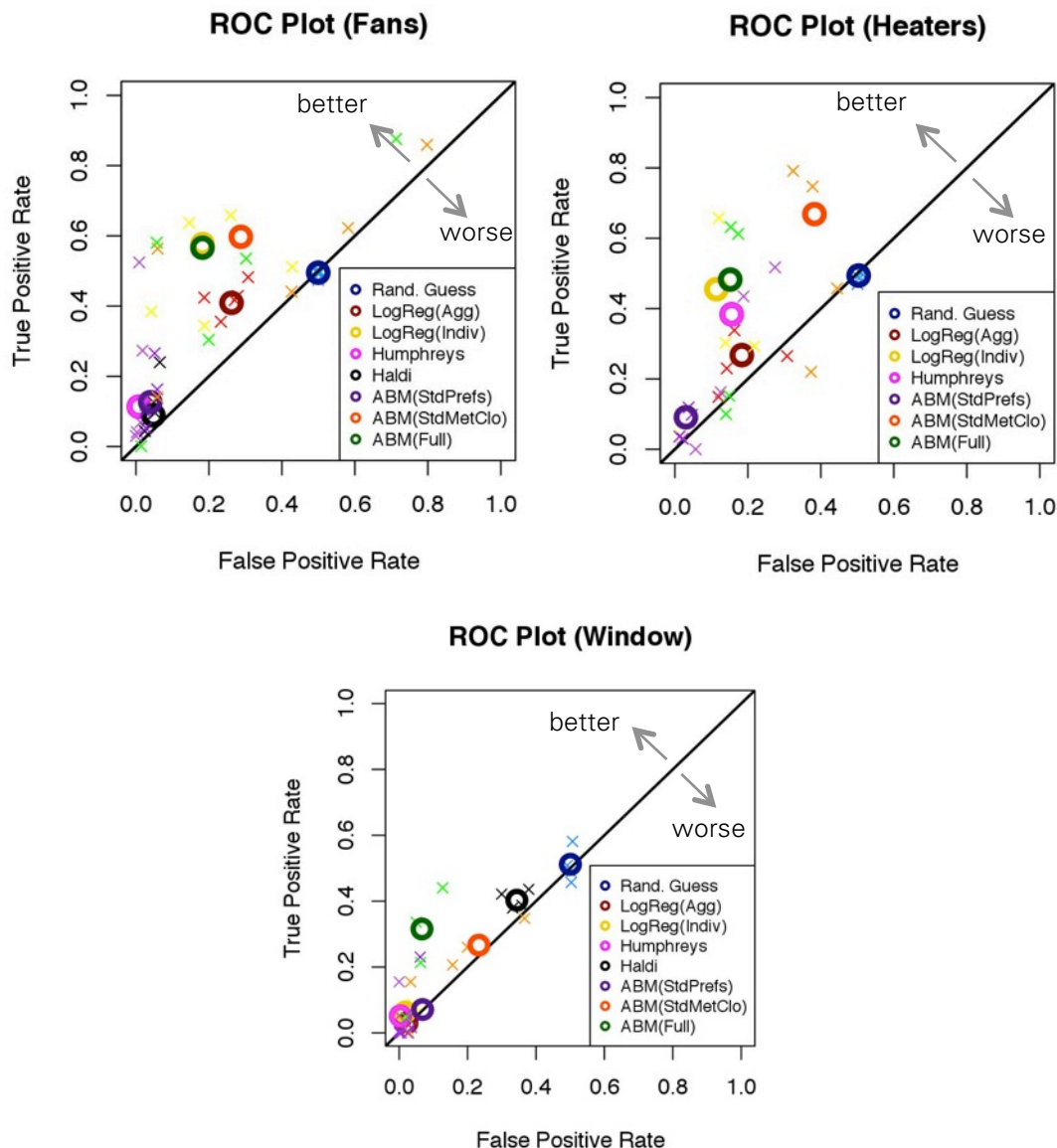

Figure 5 Individual-level prediction metrics in the receiver-Operating Characteristic (ROC) space, where the diagonal represents a Random Guess model. Note: large circles are overall result for given model, while smaller X's are result for each individual field occupant simulated.

predict fan use (low true and false positive rates). This result suggests that the apparent preference for window opening over fans in the naturally ventilated offices of the Haldi study does not apply to the air-conditioned context and sub-tropical climate of the Friends Center validation data.

3.2.2 Quality of Aggregate Predictions

Figure 6 shows that the full ABM effectively reproduces qualitative trends in aggregate behaviour across the seasons. Note that the Figure only shows results for simulated seasons where the given behaviour is expected to have the greatest intensity; aggregate prediction statistics for all four simulated seasons are indicated in Table 2. Examining the R^2 and RMSE values in the Table, it is evident that on the aggregate level, the predictive performance of the full ABM is comparable to that of the individually-fit logistic regression models, and better than that of all other modelling options.

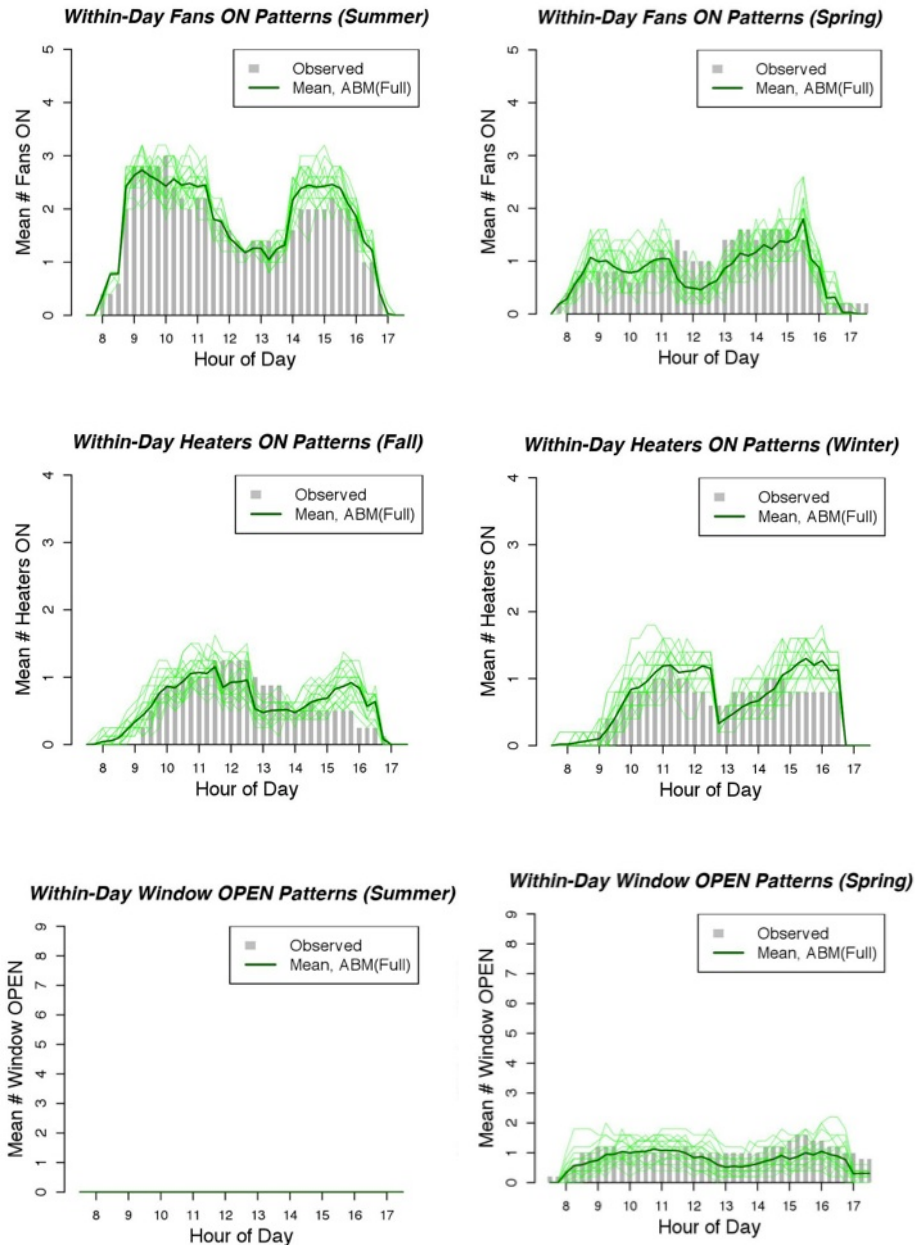

Figure 6 Comparison of observed and simulated average daily trends in aggregate behaviour for each season, using the full ABM. Note: Window opening is not observed or predicted in summer; lighter lines represent individual simulation runs for the full ABM.

On the aggregate level of prediction, the modified ABM options show the same tendencies to over and under-predict behaviour as they did on the individual level, yielding lower R^2 values and higher RMSE values than for the full ABM. While the R^2 values for the model with standard agent acceptability ranges suggest that it captures the shape of changes in aggregate fan and heater behaviour (but not the magnitude), the model with standard agent clothing and metabolic rates fails to capture the lag in first daily use of heaters, thus yielding a lower R^2 value for this behaviour.

Of the logistic regression models, the individually fit regressions are best able to reproduce aggregate dynamics in fan and heater use. It is notable, however, that this type of model under-predicts aggregate use of windows, given the general rarity of this behaviour in the field data used to calibrate the logistic regression parameters.

3.2.3 Reproduction of Stylized Facts

The final validation exercise examined how well each of the three ABM options was able to reconstruct the commonly reported logistic regression relationships between behaviour probabilities and indoor operative temperature, where the baseline regression relationships are derived from the Friends Center field data for the simulation run period.

Results are shown in the regression plots of Figure 7. From the Figure, it appears that regressions fit to outputs of the full ABM closely track the baseline curves; regressions fit to the other two versions of the ABM deviate significantly from these baselines. In particular, the ABM with standard agent clothing and metabolic rates tends to over-predict the probability of each behaviour, while the ABM with standard agent acceptability ranges under-predicts behaviour probabilities – consistent with the findings for these models in the previous two sub-sections. Similar results are observed when behaviour probability is related to outdoor temperature (plots not shown).

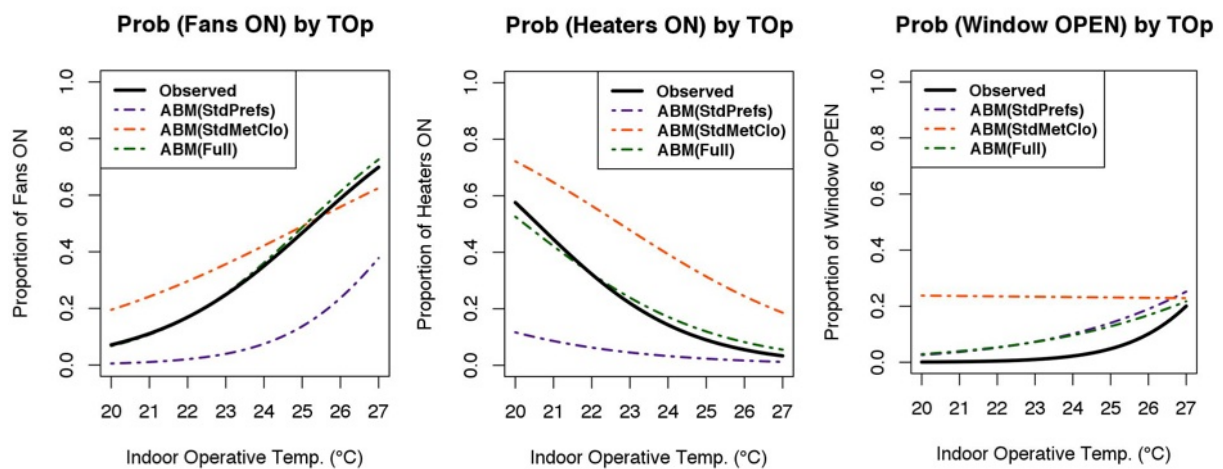

Figure 7 Friends Center derived logistic regression trends in behaviour probability vs. regression trends fit to simulated behaviour data generated with three ABM options.

4 Discussion

4.1 General Comments

By adopting the individual occupant as the basic unit of behaviour simulation in buildings, the developed ABM attempts to directly consider the real mechanisms behind behavioural actions at the individual level, placing thermal perception, comfort, and behavioural action under one simulation umbrella. Under this approach, key determinants of individual-level behaviour differences (and associated zone and building-level differences) are accounted for explicitly in the model construction and execution, improving the model's generality. Here, it is noted that the ABM does not use field-calibrated relationships between behaviour outcomes and environmental stimuli to generate its predictions, as is commonly done in the existing behaviour modelling literature. Instead, the model's predictive performance depends on the realism with which its agents' attributes are specified (i.e. morning clothing, metabolic rate values); the accuracy with which agent comfort levels can be determined from general comfort probability distributions (see Langevin et al (2013b)); and the strength of the theoretical foundation on which its agents' rules are based.

In model validation results, the full ABM yields favourable predictive performance when compared to regression-based behaviour modelling approaches. For both individual and

aggregated behaviour outcomes, the full ABM performs as good as or better than a logistic regression model of behaviour separately calibrated for each occupant in the Friends Center field study; and significantly better than a logistic regression model of behaviour calibrated to grouped occupant data from the Friends Center. In the case of the former regression approach, the incorporation of individual behaviour differences clearly improves the quality of predictions over the group-level regression; yet, it is impractical to fit separate regression curves for all the individuals or individual types in a building in order to predict the building's behaviour outcomes. Moreover, such curves do not accommodate the consideration of situational factors not present in their calibration (i.e. introduction of alternative behavioural options, new behaviour constraints, etc.). In offering predictive capabilities comparable to those of the individually fit regressions without relying on curve fitting, the full ABM presents a viable platform for considering important inter-individual differences in behaviour while also remaining flexible to the introduction of behaviourally significant changes in the building context.

4.2 Relation to Whole Building Energy Simulation

The full ABM is structured for integration with whole building energy simulation programs. The exchange requires reading in zone-level environmental information from the energy simulation at each time step; determining aggregated behaviour outcomes via the behaviour model; and using these outcomes to modify relevant input schedules in the energy simulation for the next time step. Currently, this exchange has been implemented in a Human And Building Interaction Toolkit (HABIT) that couples the full ABM in Matlab with EnergyPlus via the Building Controls Virtual Test Bed (BCVTB); this toolkit is the subject of a future paper.

4.3 Model Limitations

Development and validation of the full ABM relies on field data from a mid-sized, air-conditioned building; accordingly, the applicability of the model is currently limited to this type of field setting. In particular, while it is believed that the basic rules for agent behaviour could be successfully extended to other building types, it is not known whether certain assumptions of the current model setup, such as that regarding the sequencing of actions, could be successfully applied across different built contexts. In naturally ventilated buildings, for example, the increased propensity to open windows may suggest that this behaviour is generally taken before the use of fans, perhaps because window use is more acceptable and viable in these buildings, which tend to be situated in more moderate climates. Future work should thus attempt to repeat the validation procedure reported in this paper on similar field data collected from other office types, and in particular from naturally ventilated offices.

Another possible limitation of the full ABM is its basic handling of behavioural constraints, which may require further development with supporting field data. Personal constraints relating to one's values and/or controls knowledge, for example, are not yet applied in the execution of the full ABM, as it is not clear from the field data whether or how these constraints actually operate on behaviour, despite their suggested importance in previous ABM studies (Andrews et al, 2011); indeed, such constraints may already be built into occupants' reported thermal acceptability ranges. Future work should more closely examine the significance and operation of plausible constraints on behavioural action to determine whether adding complexity to the full ABM in this area is warranted.

Finally, the full ABM does not consider behavioural adaptations that previous research and the authors' field study suggest do not originate for primarily thermal reasons, including: consumption of warm/cold drinks; opening/closing doors/blinds; and turning on/off lights. While the validation results above indicate the current ABM yields acceptable predictive performance without considering non-thermal behaviours, such behaviours may nevertheless influence thermal comfort outcomes, and some are also significant in their own right from an energy use perspective (i.e. lighting behaviour).

Accordingly, future work should seek to incorporate non-thermally driven behaviours into the current ABM when such behaviours are determined to have important effects on comfort and/or energy use. It is envisioned, for example, that lighting and blind use could be folded into the PCT-based agent behaviour algorithm by replacing thermal sensation with visual sensation as the perception of focus. This sensation could be represented by an appropriate physical variable like lumen level, which would then be compared to an individual's acceptable range of lumen levels to determine the need for lighting/blind adaptations. Alternatively, zone-level changes in lighting/blind state could be accounted for alongside individual thermal adaptations by sampling from aggregate light/blind use probability distributions available in the existing literature (i.e. Haldi and Robinson (2010)), Reinhart (2004), Hunt (1980)).

5 Conclusion

This paper has used thermal comfort and behaviour data from a one-year field study in a mid-sized office building to develop and validate an agent-based model (ABM) of building occupants' thermally adaptive behaviours. The full ABM was described using a standard protocol. Validation of the full ABM assigned simulated agents the personal characteristics and environmental context of real office occupants in the case study; executed the model; and compared model's resulting predictive performance to that of several other behaviour modelling options. The predictive performance of the full ABM compares favourably to that of the other modelling options tested, on both the individual and aggregate levels. It is hoped that future studies can build from the reported ABM and its underlying field data in advancing more comprehensive and flexible simulations of the adaptive interactions between human occupants and their surrounding built environments.

Acknowledgements

This work was supported by a U.S. National Science Foundation Graduate Research Fellowship. We thank Friends Center Executive Director Patricia McBee, Friends Center Building Manager Wil Mason, and all the Friends Center occupants for their gracious support of our field study.

References

- Andrews, C.J., Yi D., Krogmann U., Senick J.A., Wener R.E., 2011. Designing Buildings for Real Occupants: An Agent-Based Approach. *IEEE Transactions on Systems, Man, and Cybernetics – Part A: Systems and Humans*, 41 (6), pp 1077-1091.
- ASHRAE, 2010. Standard 55-2010-Thermal Environmental Conditions for Human Occupancy. Atlanta, GA: ASHRAE.
- Azar E and Menassa C., 2012. Agent-Based Modeling of Occupants and Their Impact on Energy Use in Commercial Buildings. *Journal of Computing in Civil Engineering*, 26(4), pp 506-518.

- CEN, 2007. Indoor environmental input parameters for design and assessment of energy performance in buildings: addressing indoor air quality, thermal environment, lighting and acoustics, EN15251. Brussels: CEN.
- Fanger, P.O., 1970. *Thermal Comfort*. Copenhagen: Danish Technical Press.
- Goto, T., Toftum, J., de Dear, R., Fanger, P.O., 2006. Thermal sensation and thermophysiological responses to metabolic step-changes. *International Journal of Biometeorology*, 50 (5), pp 323-332.
- Grimm V., Berger U., DeAngelis, D.L., Polhill, G.J., Giske, J., Railsback S.F., 2010. The ODD protocol: A review and first update. *Ecological Modelling*, 221 (23), pp 2760-2768.
- Haldi, F. and Robinson, D., 2008. On the behaviour and adaptation of office occupants. *Building and Environment*, 43(12), pp 2163-2177.
- Haldi, F. and Robinson, D., 2009. Interactions with window openings by office occupants. *Building and Environment*, 44 (12), pp 2378-2395.
- Haldi, F. and Robinson, D., 2010. Adaptive actions on shading devices in response to local visual stimuli. *Journal of Building Performance Simulation*, 3, pp 135-153.
- Hong, T., 2013. *Occupant Behavior: Impact on Energy Use of Private Offices*. Berkeley: Lawrence Berkeley National Laboratory.
- Humphreys, M.A., 1997. An Adaptive Approach to Thermal Comfort. In: Clements-Croome, D.J., ed. *Naturally Ventilated Buildings: Buildings for the Senses, Economy and Society*. London: E & FN Spon.
- Humphreys, M.A. and Nicol, J.F. Do people like to feel 'neutral'? Exploring the variation of the desired thermal sensation on the ASHRAE scale. *Energy and Buildings*, 39 (7), 867-874.
- Hunt, D.R.G., 1979. Predicting artificial lighting use - a method based upon observed patterns of behavior. *Lighting Research & Technology*, 12(1), pp 7-14.
- IFMA, 2009. *Temperature Wars: Savings vs. Comfort*. Houston: IFMA.
- Langevin J., Wen, J., and Gurian, P.L., 2013a. Tracking Long-Term Occupant IEQ Outcomes: A Longitudinal Survey Tool. *IAQ 2013*, October 15-18, Vancouver, CAN.
- Langevin, J., Wen J., and Gurian, P.L., 2013b. Modeling thermal comfort holistically: Bayesian estimation of thermal sensation, acceptability, and preference distributions for office building occupants. *Building and Environment*, 69, 2013, pp 206-226.
- Macal, C.M. and North, M.J., 2010. Tutorial on agent-based modelling and simulation. *Journal of Simulation*, 4, pp 151-162.
- Metz, C.E., 1978. Basic principles of ROC analysis. *Seminars in Nuclear Medicine*.
- Montgomery D.C., Jennings C.L., Kulahci, M., 2008. *Introduction to Time Series Analysis and Forecasting*. Hoboken, NJ: Wiley.
- Nicol, J. F., 2001. Characterising occupant behaviour in buildings: Towards a stochastic model of occupant use of windows, heaters and fans. *Seventh International IBPSA Conference*. Rio de Janeiro, Brazil, August 13-15, 2001.
- Powers, W.T., 1973. *Behavior: The Control Of Perception*. New Canaan, CT: Benchmark.
- Rand, W.M. and Rust, R.T., 2011. Agent-Based Modeling in Marketing: Guidelines for Rigor. *International Journal of Research in Marketing*, 28 (3), pp 181-193.
- Reinhart, C., 2004. Lightswitch-2002: a model for manual and automated control of electric lighting and blinds. *Solar Energy*, 77, pp. 121-126.
- Rijal, H. B., Tuohy, P., Humphreys, M. A., Nicol, J.F., Samuel, A., Raja, I. A., Clarke, J., 2008a. Development of adaptive algorithms for the operation of windows, fans and doors to predict thermal comfort and energy use in Pakistani buildings. *ASHRAE Transactions*, 114 (2). pp 555-573.
- Rijal, H. B., Tuohy, P., Humphreys, M. A., Nicol, J.F., Samuel, A., Raja, I. A., Clarke, J.,

- 2008b. Using results from field surveys to predict the effect of open windows on thermal comfort and energy use in buildings. *Energy and Buildings*, 39 (7), pp 823-836.
- Rijal, H.B., Tuohy, P.G., Humphreys, M.A., Nicol, F., Samuel, A.A., 2011. An algorithm to represent occupant use of windows and fans including situation-specific motivations and constraints. *Building Simulation*, 4 (2), pp 117-134.
- Robinson, D., Wilke U. and Haldi, F., 2011. Multi agent simulation of occupant's presence and behaviour. *12th Conference of International Building Performance Association*. Sydney, Australia, November 14-16, 2011.
- Schweiker, M. and Shukuya, M., 2009. Comparison of theoretical and statistical models of air-conditioning-unit usage behaviour in a residential setting under Japanese climatic conditions. *Building and Environment*, 44 (10), pp 2137-2149.
- Stemers, K., 2009. Yun G. Household energy consumption: a study of the role of occupants. *Building Research & Information*, 37(5-6), pp 625-637.
- Yun, G.Y. and Stemers, K., 2008. Time-dependent occupant behaviour models of window control in summer. *Building and Environment*, 43 (9), pp 1471-1482.

Appendix

A.1 ODD Point 7: Description of subroutines used in the full ABM.

- a. **SetStaticParameters:** This subroutine initializes an agent's state variables. Of particular interest is the approach used to sample agent's thermal acceptability ranges for warm and cool seasons on the seven point ASHRAE scale. This thermal acceptability sampling scheme draws from the acceptability distributions reported in Langevin et al (2013b); it is diagrammed in Figure A.1.
- b. **SampleMornClo:** This subroutine predicts an agent's clothing level at the beginning of each simulated day (when they first sit down at their desk to begin work). Subsequent clothing adjustments for the day move up/down from this morning reference value. In the routine, an agent's morning clothing is predicted using the following regression (fit to Friends Center data with 602 usable morning clothing observations):

$$\log(\text{MornClo}(d)) = \beta_0 + \beta_1 T_{out,6am} + \beta_2 Wpref + \beta_3 \text{MornClo}(d-1) + \varepsilon \quad (1)$$

where

$\text{MornClo}(d)$ = The agent's morning clothing on the current day d

$\text{MornClo}(d-1)$ = The agent's morning clothing on the previous day

$T_{out,6am}$ = Outdoor air temperature (°C) on the current day at 6 AM

$Wpref$ = A dummy variable indicating whether the median of the occupant's thermal acceptability range is warmer than "Neutral".

$$[\beta_{0...3}(\sigma_{0...3})] = [-0.94(0.042) \quad -0.01(0.001) \quad 0.18(0.025) \quad 0.73(0.057)]$$

ε = Error term, $\sim N(0, \text{RMSE}_{\text{model}})$

- c. **GetMet:** This subroutine determines the agent's current metabolic rate based on its activity in the previous time step. Table A.1 details the various activity scenarios and the metabolic rates they yield in this subroutine.

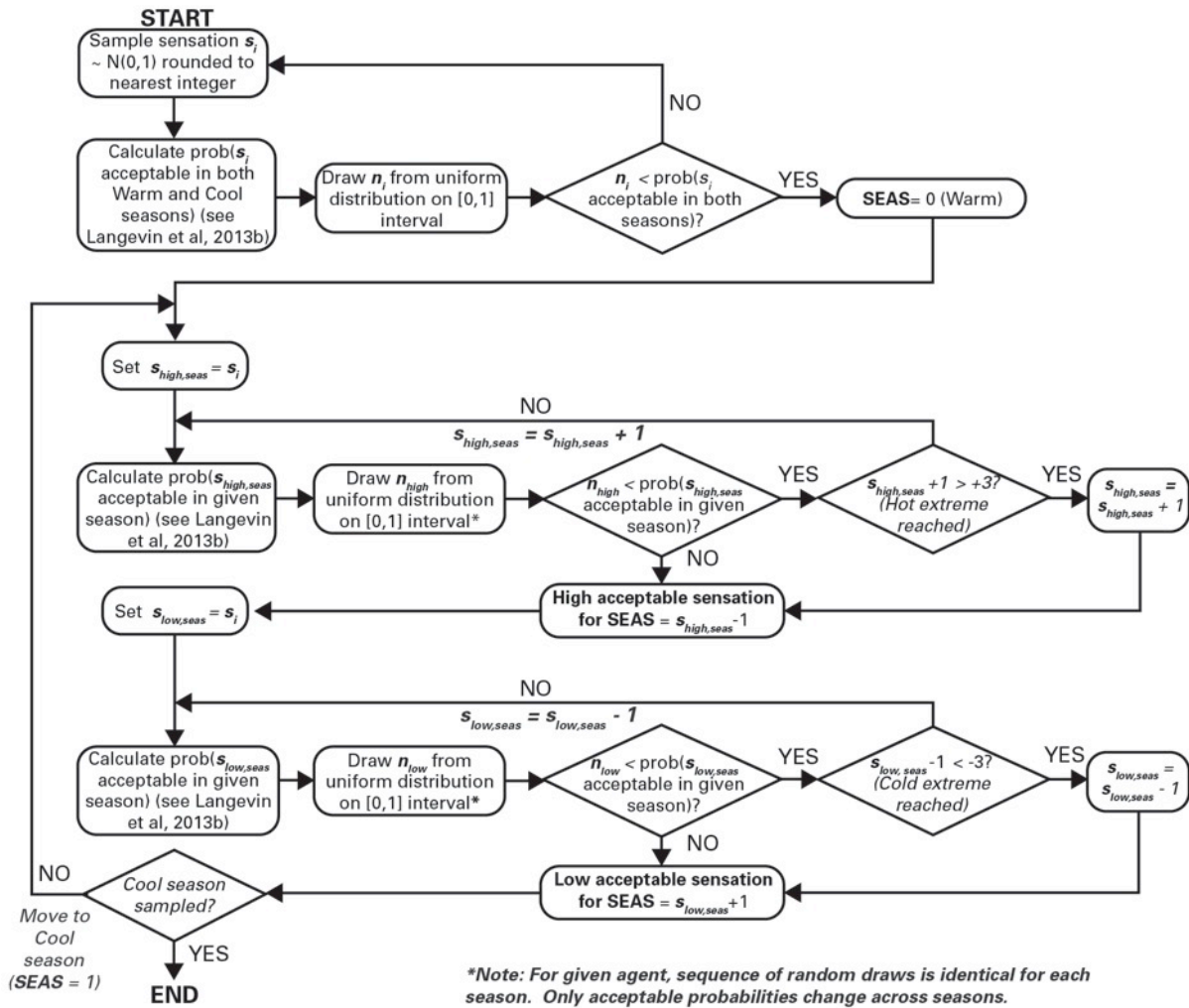

Figure A.1 Flow diagram of acceptability sampling scheme in the SETSTATICPARAMETERS subroutine.

Table A.1 Activity scenarios and associated MET values

Scenario	MET value
Agent arrived from outside bldg. (commute)	Based on commute method
Agent arrived from outside bldg. (lunch break)	1.7 (leisurely walk)
Agent arrived from other part of bldg.	1.7 (leisurely walk)
Agent has been working at desk	1.1 (seated, typing) + lagged MET ¹

¹ After an arrival, the occupant's MET value decays exponentially, with a halflife of 8 minutes (in line with Goto et al (2006)); this means an arrival MET continues to influence MET values for ~ 30 mins.

- d. **GetEnvironment:** This subroutine updates the four environmental parameters needed to calculate an agent's PMV. In doing so, it incorporates any baseline changes in the environment with environmental feedback from behaviour in the previous time step (see Table A.2). Baseline environmental information would be provided at each time step via a coupled whole building energy simulation routine.
- e. **DetermineComf:** This subroutine determines the agent's general thermal comfort using the algorithm diagrammed in Figure A.2, which draws upon the thermal sensation distributions reported in Langevin et al (2013b).

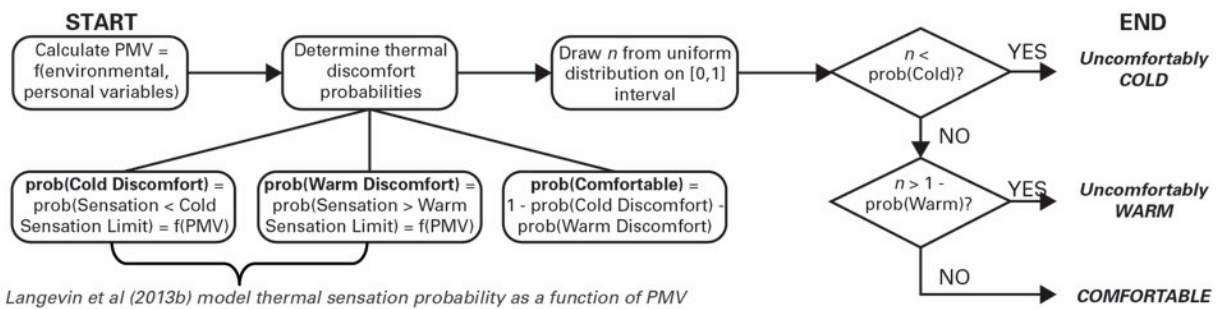

Figure A.2 Flow diagram of *GETCOMF* subroutine for determining an agent's thermal comfort level.

f. **SimulateBehaviour:** If the agent is determined to be uncomfortable, this subroutine establishes the behavioural action taken to regain comfort (if any). The process unfolds as diagrammed in Figure A.3. Note in the figure that the user defines both "action" and "action reversal" hierarchies, which determine the order in which available behaviours are taken and/or reversed. Note as well that when a given behavioural action is needed and physically possible in the office context, its ultimate availability depends on whether it passes a series of constraint checks.

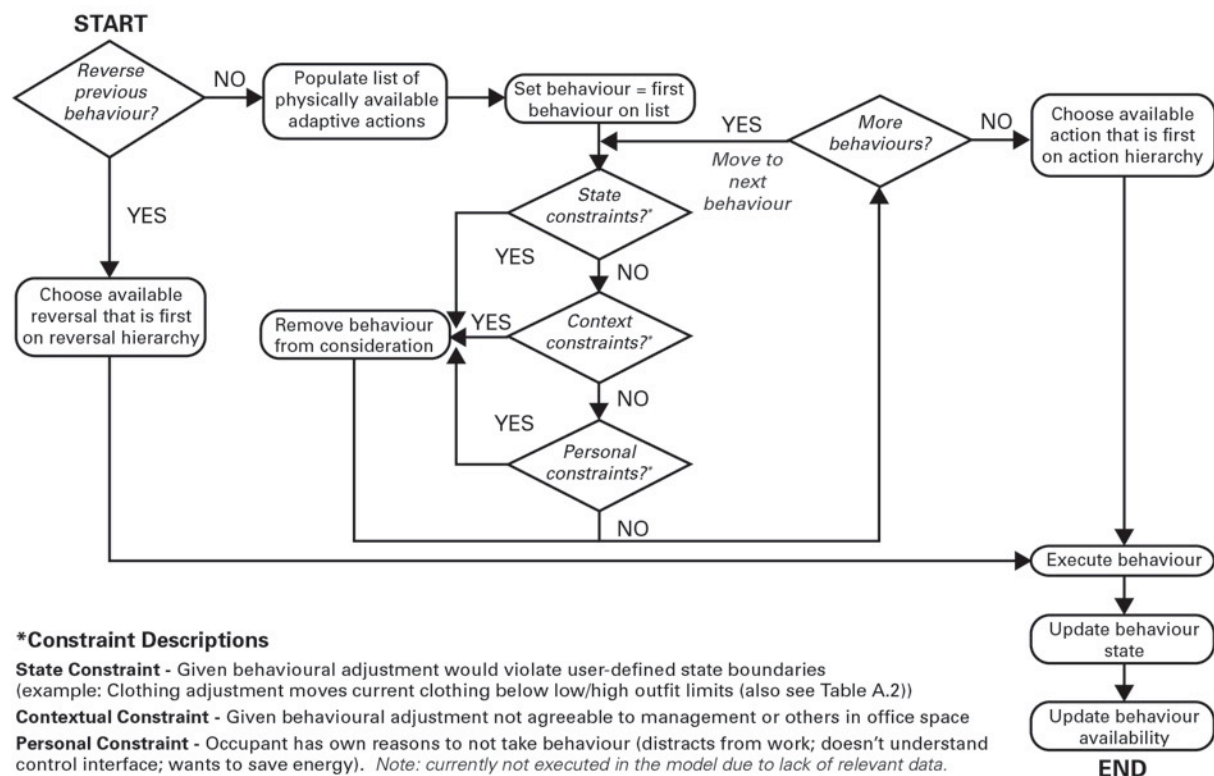

Figure A.3 Flow diagram of *SIMULATEBEHAVIOUR* subroutine for determining an agent's behavioural action.

Table A.2 presents all the behavioural possibilities implemented in the full ABM, their hierarchy, potential constraints, and the way in which their feedback on the environment and personal characteristics is accounted for.

Table A.2 Adaptive behaviours, their hierarchy, potential constraints, and feedback in the full ABM.

BEHAVIOUR	COOLS ?	WARMS ?	ORDER ¹ (Act; Reverse)	CONSTRAINTS (S= State; C=Context; P= Personal)			ESTIMATED FEEDBACK		
				S ²	C	P ³	DESCRIPTION	Δ	UNITS
Minor clothing adjustment (roll sleeves up)	◆		1; 3	◆	◆		Changes Clo	- 0.08	Clo
Major clothing adjustment (add/remove sweater)	◆	◆	2;2	◆	◆		Changes Clo	+/- 0.3	Clo
Turn on heater		◆	3;1		◆	◆	Changes air temp.	+ 1200 ⁴	Watts
Turn on fan	◆		3;1		◆	◆	Changes air velocity	+ 0.75	(m/s)
Thermostat up/mid/down	◆	◆	4;4		◆	◆	Changes air temp.	+/- 1.00	(°C)
Open window	◆		4;4	◆	◆	◆	Changes air velocity	+ 0.25	(m/s)

1 The sequencing of thermostat vs. window actions (both 4th in the above ordering) is determined by a coin toss.

2 Clothing adjustment may not take current Clo value below 0.4 (lowest typical trousers ensemble # 1 in ASH Std. 55 (2010) assuming light pants, shoes and socks) or above 1.3 (highest typical trousers ensemble in ASH. Std. 55 (2010)).

3 Personal constraints are not currently executed in agent-based model. Note it is assumed simple clothing adjustments would not engage any potential personal concerns (work disruption; control complexity; high energy use)

4 Watts can be converted to convective/radiant heat gain in zone via whole building energy simulation; for model validation work, local air temp. was simply assumed to increase by 2 °C when heater is on, with radiant temp. = air temp.

Post-occupancy and indoor monitoring surveys to investigate the potential of summertime overheating in UK prefabricated timber houses

T. Adekunle* and M. Nikolopoulou

Centre for Architecture and Sustainable Environment (CASE), Kent School of Architecture, University of Kent, CT2 7NR, *Corresponding author: toa20@kent.ac.uk

Abstract

A post-occupancy evaluation was carried out in three prefabricated timber housing developments in the UK to identify the potential of summertime overheating. All the case studies selected are recipients of various low-energy or sustainability awards built within the last eight years. Two of the case studies are modern multi-storey apartments blocks (Bridport and Stadthaus) and the third one (Oxley Woods) a housing development with ten different prototypes. A paper-based questionnaire to assess how the indoor occupants perceive and rate the overall thermal environment and use control was administered. In order to evaluate the actual performance of the case studies, indoor measurements of environmental parameters and thermal comfort surveys were conducted in Bridport and Oxley Woods during summer 2012 and in Oxley Woods only during winter 2013. A total of 65 questionnaires were collected during the post-occupancy survey, while 141 and 161 questionnaires were collected during the summer and the winter indoor monitoring surveys respectively. The paper focuses on the findings of post-occupancy and indoor measurement surveys. The post-occupancy survey suggests that there is a potential of summertime overheating in prefabricated timber houses, as more than 70% of the respondents feel 'warm' and 'hot' in the summer. Comparing these with the monitoring, it appears that the indoor temperatures tend to rise above comfort range when external temperature is above 19°C, when only 10% prefer not to be 'cooler' in summer. Occupants are subjected to temperatures above 28°C in living areas for more than 1% of total hours occupied between 08.00-22.00, while they experienced temperatures above 25°C in living areas for more than 5% between 22.00-08.00.

Keywords: Overheating, post occupancy, indoor monitoring, prefabricated timber, thermal comfort

1.0 Introduction

There has been a growing concern regarding the increase in summer period temperatures in UK dwellings, even as the climate is considered to be moderately warm, which is expected to occur regularly as global temperatures increase. Recent research has highlighted the problem with increasing summertime temperatures on the occupants' comfort in the UK, as dwellings are built to meet improved regulations. As a result, they tend to be more likely to overheat and are more sensitive to potential summertime overheating than older houses (Gupta & Gregg, 2012). Similar issues have been identified in highly insulated passive houses in Europe, where occupants are likely to experience high temperatures when such buildings are located in a climatic region with hot summers. (Mlakar & Strancar, 2010). Various researchers have addressed the issue of overheating in dwellings in the UK (Orme, *et al.*, 2003; Wright, *et al.*, 2005; Firth & Wright, 2008; Rijal & Stevenson, 2010; Jowett, 2011; Lomas & Kane, 2012, 2013; Beizaee *et al.*, 2013). Thermal mass is considered an important

parameter to improve summertime thermal comfort (Holmes & Hacker, 2008), so there are increased concerns about lightweight buildings, which potentially cannot cope with increased summertime temperatures and can lead to overheating. This paper focuses on the latter, being the first study to focus solely on prefabricated timber houses with low thermal mass.

2.0 Overheating and thermal comfort criteria

Thermal comfort is very important as it affects the perception as well as occupants' health and well-being. According to CIBSE (2010) 'overheating within a dwelling occurs when the actual indoor temperature for any given day is hot enough to make the majority of people feel uncomfortable'. This can also be experienced when the indoor temperature is exceeded long enough to make occupants feel unacceptably uncomfortable, linking overheating to one of the major reasons causing occupants' discomfort and dissatisfaction in the thermal environment.

Various indicators have been used for assessing overheating in dwellings. According to CIBSE (2006), for overheating not to occur within a dwelling, the temperature threshold (25°C/28°C) should not be exceeded for more than a reasonable duration of hours (5%/1%) throughout the year. Furthermore, indoor temperature ranges 25°C-28°C during the summer can result in an increasing number of occupants feeling hot and uncomfortable, while the majority of the occupants will feel increasingly dissatisfied when the indoor temperatures stay at or above 25°C for long duration of hours in a day. Hence, the duration of hours at which the temperatures stay at or above 25°C should not be exceeded for more than 5% of the total occupied hours per year (usually 125 hours). For bedrooms, lower temperatures are considered, as thermal comfort and quality of sleep decrease with temperatures increasing over 24°C, or exceed 26°C with ceiling fans (CIBSE, 2006). These static criteria have been used extensively to evaluate overheating risk in dwellings (Eppel & Lomas, 1992; Cohen *et al.*, 1993; Wright *et al.*, 2005; Firth & Wright, 2008; Peacock *et al.*, 2010; Lomas & Kane, 2012; Beizaee *et al.*, 2013).

As people can adapt to changing temperatures (Nicol *et al.*, 2009), the adaptive comfort criteria is used for free-running buildings (BSEN15251). In the UK, the majority of the dwellings are considered free-running in the summer, i.e. not mechanically heated or cooled. In that case, thermal comfort is considered to drift with the outdoor temperature, rising at about 0.33K per K rate as the moving average of the outdoor temperature (T_{m}) rises within the limit $10 < T_{m} < 30^{\circ}\text{C}$ (BSI, 2008). The standard also specifies different categories of comfort envelopes, depending on the temperature limits defining thermal comfort.

The current study uses both the static and dynamic criteria for evaluating overheating. The former use the number of occupied hours, 5%/25°C and 1%/28°C as indicators of moderately warm and extremely hot overheating risk for living areas, with 5%/24 and 1%/26°C, used for bedrooms.

According to BSEN15251 (BSI, 2008), the Category I provides comfort for '*high level of expectation and is applicable for spaces occupied by very sensitive and fragile persons with special requirements*' such as elderly occupants, disabled, sick and has a temperature range of 4K. The Category II provides comfort for '*normal level of expectation*'. The Category III provides comfort for '*an acceptable, moderate level of expectation and may be considered for existing buildings*'. Cat. III provides a broader temperature range of 8K. The last category (Category IV) is not often used, which provides comfort for '*values outside the criteria for the above categories and should only be accepted for a limited part of the year*'.

For the dynamic criteria, the Category II is employed, which provides comfort for ‘normal level of expectation and it is recommended to be used for new buildings and renovations’ with no more than 10% responses indicating dissatisfaction. According to the standard, the Category II applies for evaluating thermal comfort in non-residential and residential buildings and other similar buildings where rigorous tasks are not expected to be carried out and people are allowed to open or close windows and likely to adjust clothing insulation to meet the thermal conditions of their environment. The Category II applies to buildings that are not only naturally ventilated but also mechanically ventilated with no cooling done mechanically, and in summer, the buildings are likely to use unconditioned air with provision for individual means of regulating the indoor climate with use of night-time ventilation strategy, cooling fans and others that consume low-energy and a major way of adjusting indoor thermal conditions will be through windows (opening and closing). The standards suggested that Cat. II applies to all spaces in free-running dwellings that are not occupied by the vulnerable people. Cat. II provides a temperature range of 6K. The BSEN15251 provides no restriction on the acceptable limits of the category markers and 5% of hours over (warm discomfort) or lower (cold discomfort) the category limit will be considered as an indicator in this study.

3.0 Case study description

The three case studies (Bridport House, Oxley Woods and Stadthaus) were identified in order to investigate the potential of summer overheating in low-carbon prefabricated timber houses, with the material of construction being the main criterion. The case studies were also selected based on their sustainability credentials, all being recipients of various awards for sustainable or low energy design, or highly rated in terms of UK building sustainability rating tool and similar thermal performance (table 1). All the case studies are located in the South-East of England, which is prone to overheating and at higher risk, under the various climate change scenarios (Orme, et al., 2003; Porritt, *et al.*, 2012; Rijal & Stevenson, 2010).

Table 1: U-values (W/m^2K) for the three case studies

Case study	U-values for the different components (W/m^2K)		
	Walls	Windows	Roof
Bridport House	0.14	1.37	0.12
Oxley Woods	0.12	1.7	0.17
Stadthaus	0.16	1.98	0.20

Bridport House (51°53'50N 0°08'61W), designed by Karakusevic Carson Architects and owned by the London Borough of Hackney, is a prefabricated timber block of flats built with cross-laminated timber (CLT). Completed in 2011, the total floor area of the building is 4,220m². It comprises of 41 flats built over two joint blocks, one 8-storey high with stair to access and the other 8-storey with separate stairs and lifts for the users to access the building. The floor to ceiling height is 2.65metres; the U-values are presented in table 1.

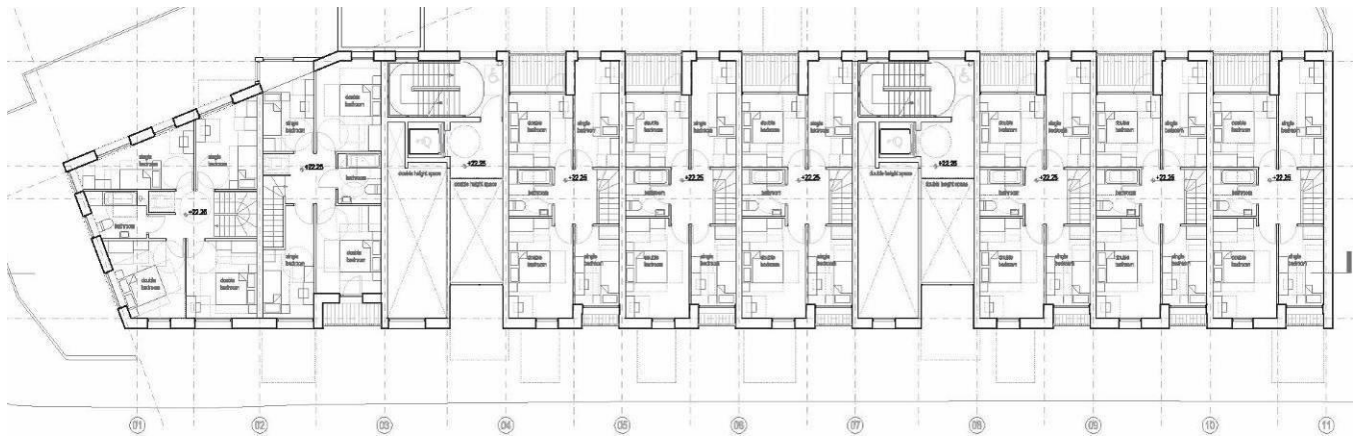

Figure 1: Typical Upper Floor Plan (Karakusevic Architects)



Figure 2: South facing elevation of Bridport House in Hackney showing eight-storey and five-story block of apartments

Oxley Woods, designed by Rogers Stirk Harbour & Partners is located in Milton Keynes (52°0'36N 0°48'5W). It is a prefabricated timber housing development built with Structural Insulated Panel (SIP). The construction of the development started in 2005 and is still ongoing. Oxley Woods has 10 different prototypes in a 145-unit development with an average density of 40 dwellings per hectare (dph). At the time of the surveys, 116 houses had been completed and 29 houses were yet to be built. The internal spaces of the houses have floor to ceiling height of 2.35m.

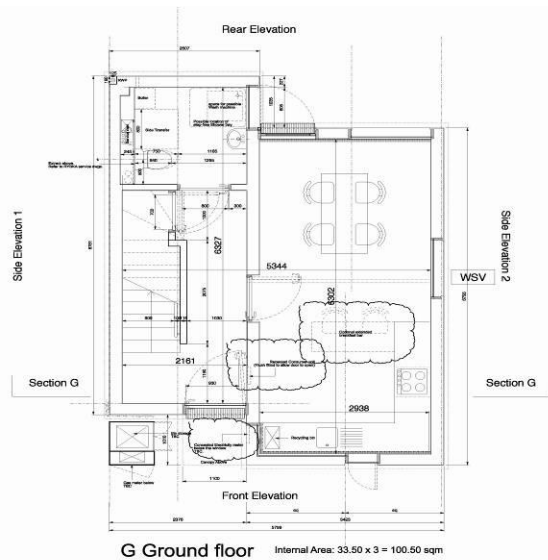

Figure 3: Ground floor plan of one of ten prototypes and a view showing arrangement of blocks at Oxley Woods Housing Development

Stadthaus, designed by Waugh Thistleton Architects, is located in Murray Grove (51°53'50N 0°05'32W), in East London. It was completed in 2009. Stadthaus is a 9-storey building built with prefabricated Cross-Laminated Timber (CLT) and is regarded as the tallest residential timber building in the world. Stadthaus has 29 flats positioned at corners around a dual core, with different stairs and lifts to access privately rented flats and socially rented flats. Nine out of 29 flats are socially rented while the remaining 20 flats are privately rented or owned.

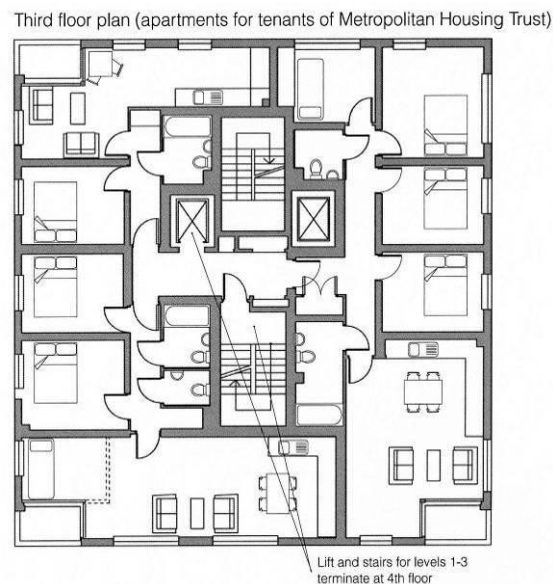

Figure 4: Typical Upper Floor Plan and Stadthaus Housing at Murray Grove in East London

4.0 Methodology

The methodology included post-occupancy surveys, monitoring of the internal environment and comfort surveys.

4.1 Post-occupancy surveys

Post-occupancy surveys are critical to appreciating the thermal environment in buildings, while it helps to understand and compare the nature and frequency of occupants' complaints of feeling warm or hot that cannot be obtained during surveys (Nicol & Roaf, 2005). Each questionnaire had 20 questions, requiring 7-10 minutes to complete. The respondents were asked to evaluate their overall thermal comfort and thermal satisfaction in different seasons, along with different aspects of control of the thermal environment. Additionally, basic information about age, gender, occupancy status and duration of occupancy were collected. In all, 131 questionnaires were distributed to all the residents of the three case studies and 65 completed questionnaires were returned.

4.2 Environmental Monitoring

The indoor monitoring during the summer surveys was carried out at Bridport from 29/6/12 to 12/7/12 and at Oxley Woods from 20/7/12 to 31/7/12. The winter survey was carried out at Oxley Woods between 28/1/13 and 8/2/13. No access was allowed at Stadthaus to conduct indoor monitoring and comfort surveys. Air temperature and relative humidity were recorded using HOBO and Tinytag sensors installed on the internal walls at the height of 1.1m above floor level. Four flats were monitored at Bridport and 5 houses at Oxley Woods. In total, 17 spaces comprising of living areas and bedrooms were monitored at the case studies.

The households monitored at Bridport were selected from three flats on the ground floor with different orientations (FL1GFL- South facing, FL1GFLK- East facing, FL8GFL- North facing), three on the first floor (FL1FFB- Southwest facing, FL7FFB- East facing, FL8FFSB- Northeast facing) and one at the second floor (FL35SFL- West facing). The houses monitored at Oxley Woods were also chosen from different orientations (A38ML- South facing, A6ML- South facing, A1WL- East facing, A142HA- West facing and A162HA- North facing).

The outdoor weather data was collected from nearby meteorological stations to the case studies, from London City Airport and from Luton Airport weather stations for Bridport and Oxley Woods respectively.

4.3 Comfort Surveys

The occupants of the houses and the flats monitored were asked to complete subjective questionnaires three times per day enquiring their thermal comfort state (using the seven-point ASHRAE thermal sensation scale (where 1 is cold and 7 is hot) and a five-point preference scale (1 is much cooler, 2 is cooler, 3 is no change, 4 is warmer, 5 is much warmer). Additional information on clothing insulation and activity in the last 15 minutes was also collected. Overall, 141 questionnaires were collected during the summer surveys and 106 during winter. The completed questionnaire information from the surveys and related environmental data was entered on the statistical programme SPSS for further analysis.

5.0 Data Analysis and Results

5.1 Analysis of post-occupancy surveys

A further breakdown of questionnaires administered showed that 26 questionnaires were returned from Bridport House, 26 from Oxley Woods and 13 from Stadthaus. There were 25 male (38.5%) and 40 female (61.5%) responses.

Across all the case studies, there is an overwhelming response for the warm part of the scale for the summer period, with 81% of the occupants feeling ‘warm’ or ‘hot’ at Bridport and Oxley and 70% at Stadthaus (Figure 5). On the contrary, in winter, there is a noticeable shift of thermal sensation with more than half of the responses at either ‘neutral’ or ‘slightly warm’ part of the scale (Figure 6), with the mean thermal sensation focusing around neutrality (Table 2).

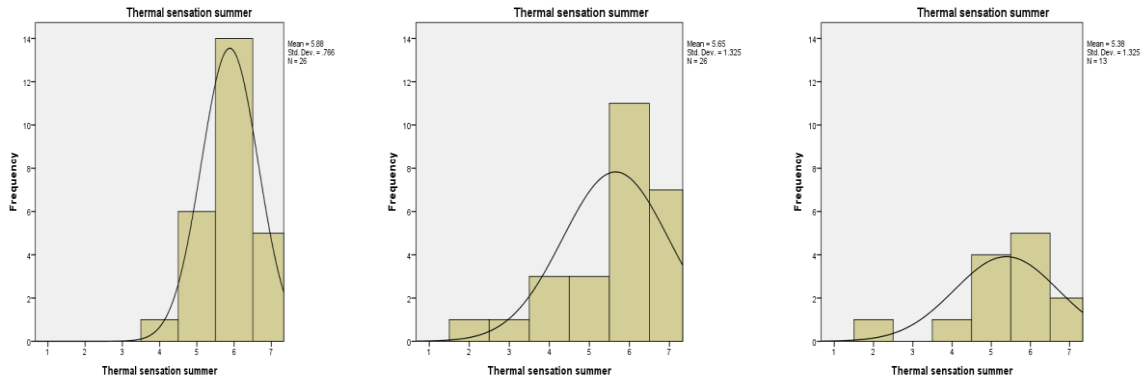

Figure 5: Distribution of thermal sensation during the summer at Bridport House (left), Oxley Park (middle) and Stadthaus (right)

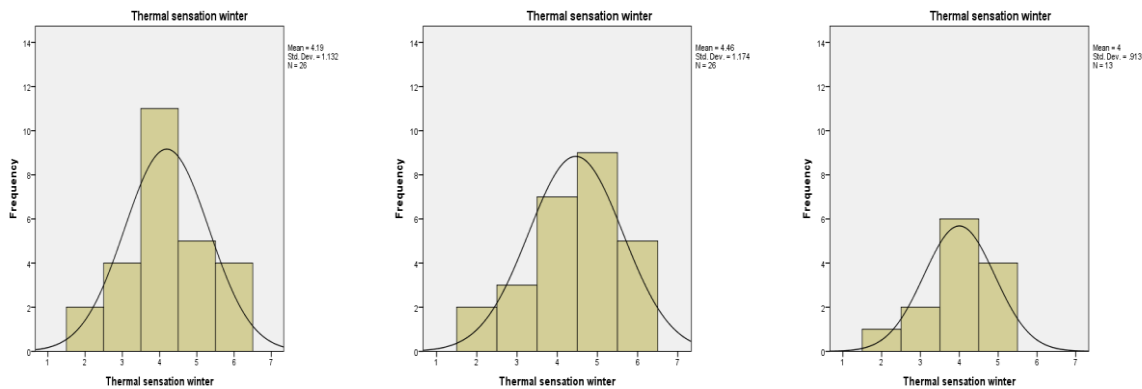

Figure 6: Distribution of thermal sensation during the winter at Bridport House (left), Oxley Park (middle) and Stadthaus (right) (where 1= cold, and 7 = hot)

Table 2: Mean responses for thermal sensations and overall thermal comfort in the summer and the winter from the post-occupancy surveys

	Thermal sensation		Overall thermal comfort	
	summer	Winter	Summer	winter
Bridport House	5.58	4.19	3.35	6.04
Oxley Woods	5.65	4.46	3.85	4.58
Stadthaus	5.38	4.00	4.54	5.69

A 7-point scale (from 1 very dissatisfied to 7 very satisfied) was also used for thermal satisfaction. Overall, occupants are satisfied with their thermal environment during the

summer, with the lowest levels of satisfaction at Bridport (Fig. 7). Bridport, similarly, has the lowest evaluation for thermal comfort (Fig. 8).

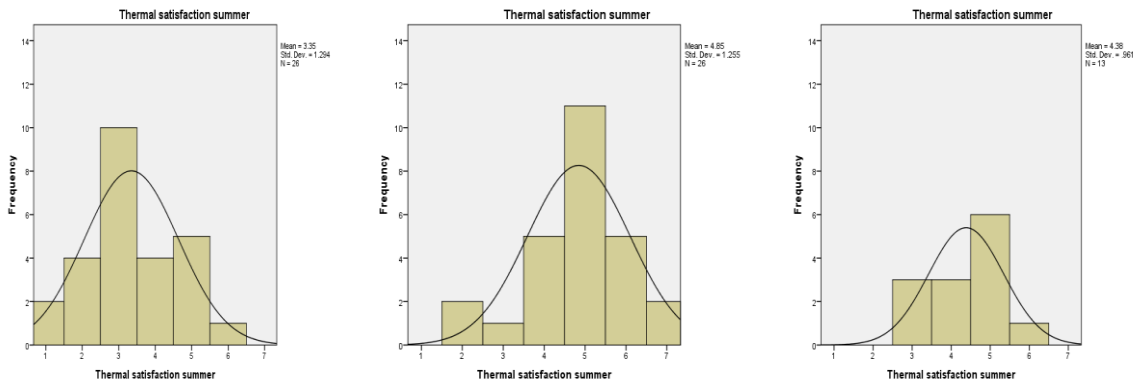

Figure 7: Distribution of thermal satisfaction during summer at Bridport House (left), Oxley Park (middle) and Stadthaus (right) (from 1=very dissatisfied to 7=very satisfied)

On the contrary, in winter, there is a noticeable shift in overall thermal comfort vote, with more than half of the responses at either 'comfortable' or 'very comfortable', and 65% of the occupants satisfied with the overall thermal comfort (Figure 9).

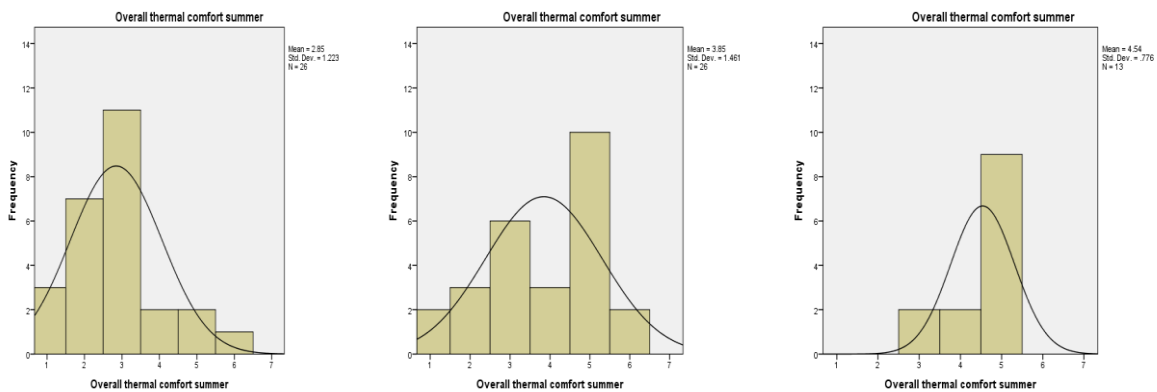

Figure 8: Distribution of overall thermal comfort during summer at Bridport House (left), Oxley Park (middle) and Stadthaus (right) (Scale: 1=very uncomfortable, 7=very comfortable)

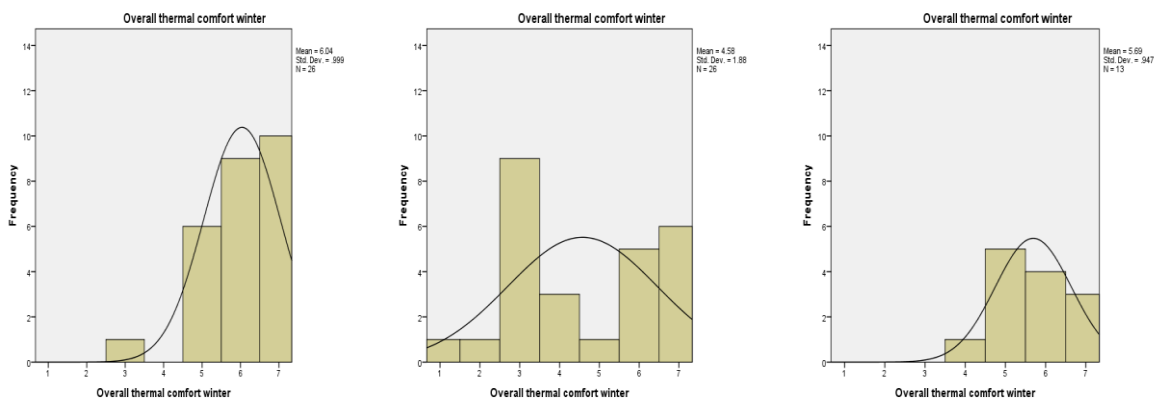

Figure 9: Distribution of overall thermal comfort during winter at Bridport House (left), Oxley Park (middle) and Stadthaus (right) (Scale: 1=very uncomfortable, 7=very comfortable)

5.2 Analysis of environmental monitoring surveys

Throughout the monitoring period, the external temperature at Bridport varied from 11°C on 12/7 to a peak of 23.5°C on 5/7 (Figure 10); while the external temperature at Oxley Woods varied from 8°C on 30/7 to a peak of 27.5°C on 24/7 (Figure 11). The beginning of monitoring period at the case studies (Bridport and Oxley Woods) was considered to be wet and mild. Starting from 4/7, the average daily temperature rose above 19.2°C for two consecutive days at Bridport while beginning from 23/7, the average daily temperature exceeded 19.2°C for four successive days reaching 21.2°C on 25/7 at Oxley Woods but reducing back to 18.3°C on 27/7. This is considered along with the findings from epidemiology, with the external temperature rising above 19°C providing a critical threshold, for increase mortality (Hajat *et al.*, 2002). The average daily temperature for the remaining days during the monitoring period was below 19°C at both locations of the case studies. The external temperature during the two days at Bridport did not rise above 25°C; while the external temperature during the four successive days at Oxley Woods rose above 25°C for 25 hours, with 24/7 and 25/7 having 8 hours each over 25°C and the hottest days (24/7 and 25/7) having 13 hours each above 19°C.

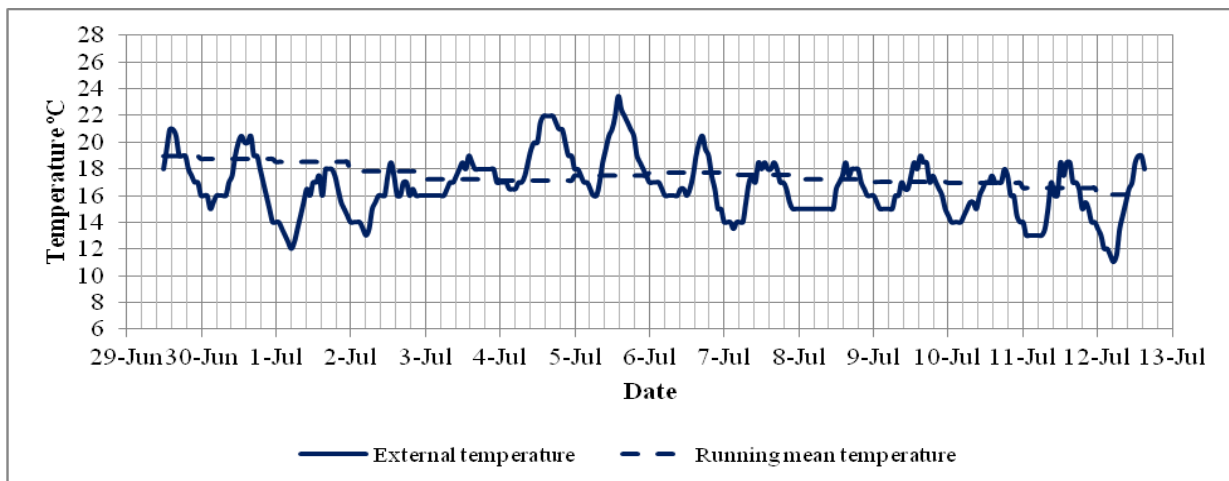

Figure 10: External temperature and running mean of daily average temperature during the monitoring period at Bridport House

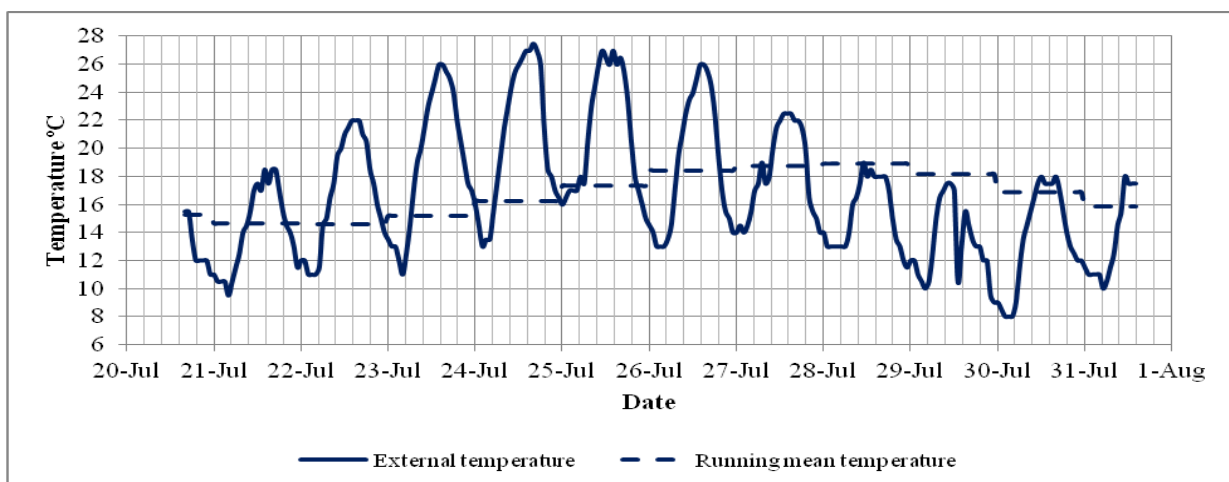

Figure 11: External temperature and running mean of daily average temperature during the monitoring period at Oxley Woods

The running mean temperature of the measured external temperature, T_{rm} , (Figures 10-11) as defined in BSEN15251 (BSI, 2008) reached 19°C on 29/6 at Bridport and 19°C on 28/7 at Oxley Woods. The average running mean temperatures during the monitoring period were 17.5°C at Bridport and 16.8 at Oxley Woods. The results suggest that the overall monitored period was greatly cooler than normal for the time of the year when compared to the hottest month (August) with the average monthly temperatures of 23°C and 22.5°C recorded in London and Luton respectively. The running mean temperatures, T_{rm} , throughout the monitoring period rose above 16°C for 100% of the time and 18°C for 19% of the time at Bridport compared with the T_{rm} value at Oxley Woods which exceeded 16°C for 64% and 18°C for 37% respectively.

In all the living areas monitored at Bridport, the average temperature between 08:00 - 22:00 was 22°C, with the hottest living room having a mean of 23.8°C and a maximum of 25.4°C (Figure 12). At Oxley Woods, the average temperature between 08:00 - 22:00 in all the living areas monitored was 23.3°C, with a mean temperature of 24.2°C recorded at the hottest living room and a maximum of 30°C (Figure 13).

The indoor relative humidity was within the comfort range of 40% - 60%.

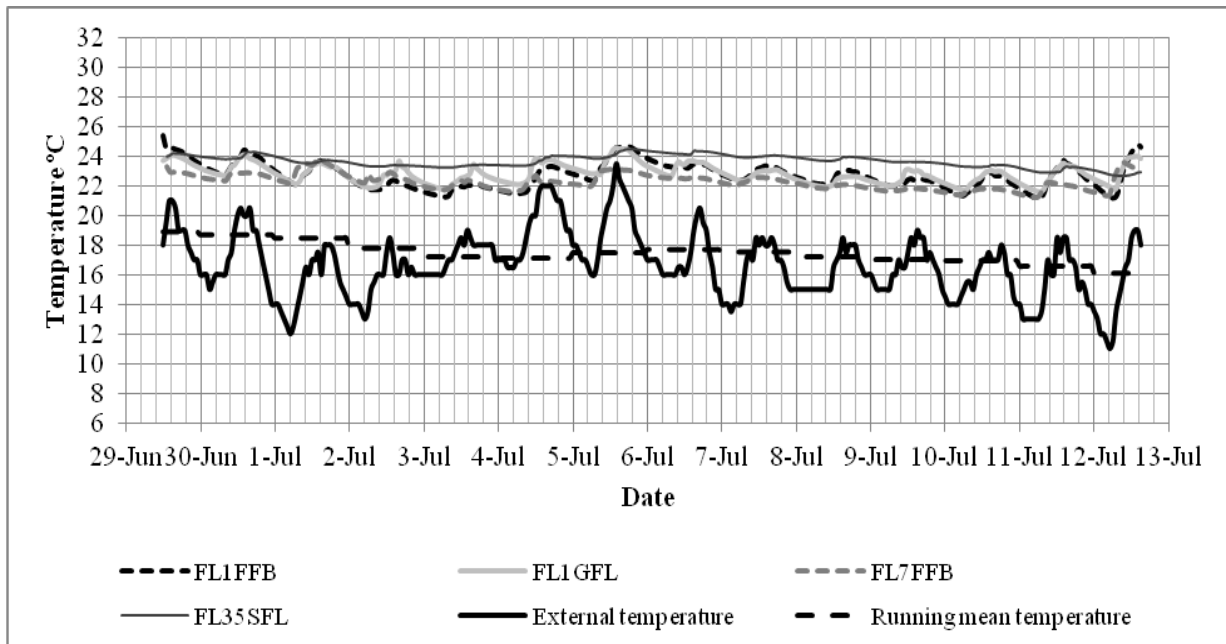

Figure 12: Living rooms and bedrooms monitored in different flats at Bridport

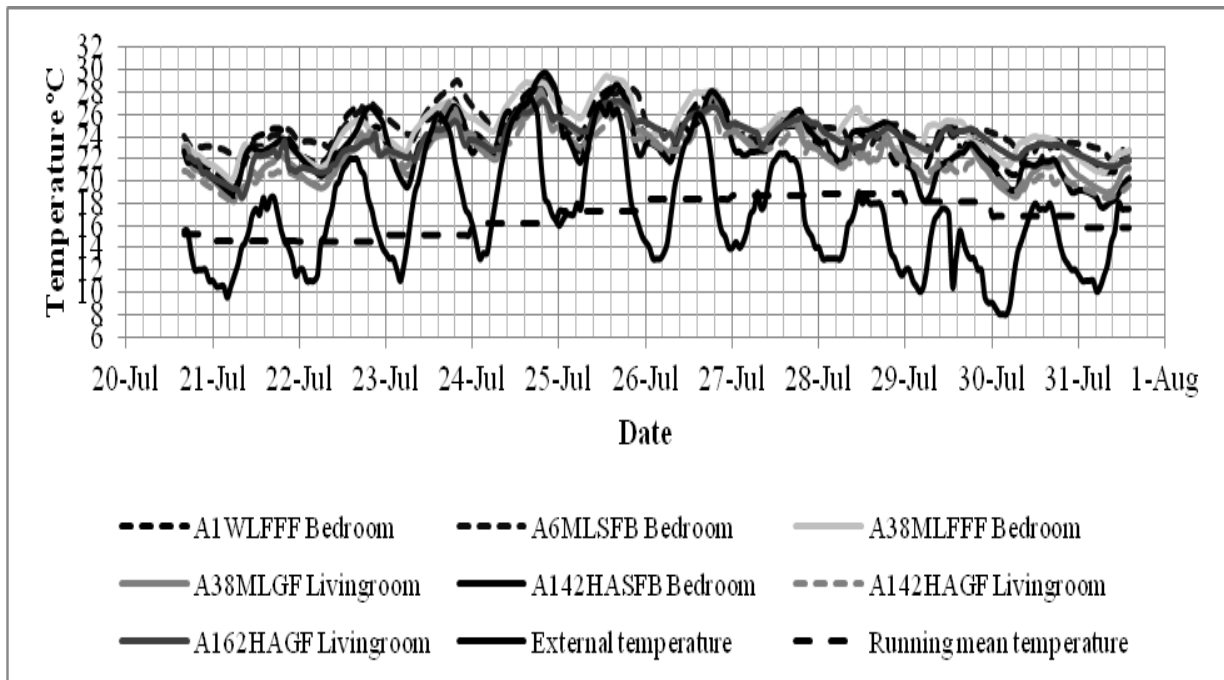

Figure 13: Living rooms and bedrooms monitored in 5 different houses at Oxley Woods

5.3 Analysis of comfort surveys

Subjective questionnaires were also administered throughout the monitoring period to the occupants that participated in the indoor monitoring survey. In all, 93 male (66%) and 48 female (34%) responses were received in the summer; while in the winter there were 58 male (55%) and 48 female (45%) responses.

The analysis of the comfort surveys (Figures 14-17) show a distribution clustered around the central categories with more than half of the responses feeling ‘comfortably warm’ with a moderately even distribution of votes varying between ‘neither cool or warm’ and ‘slightly warm’ in summer. The results suggest that only 38% feel ‘warm’ at Oxley Woods while 75% feel ‘warm’ at Bridport during summer (Figure 14), despite the fact that the external temperatures were higher during the surveys in Oxley Woods.

Further analysis highlighted that the majority of occupants at Oxley Woods had lived in the houses between 19 and 36 months, over 90% of the residents owned the properties and majority of the residents spent more hours in the house per day. This suggests they have a better understanding of how to adapt to their indoor environment when compared to the majority of occupants at Bridport House, who had been living in the building for less than six months at the time of survey.

In all spaces monitored at the case studies, more than 50% of the spaces recorded temperatures that were above the comfort range. The period of monitoring at Bridport was wet and mild so the number of hours at which external temperature rose above 19°C was very small.

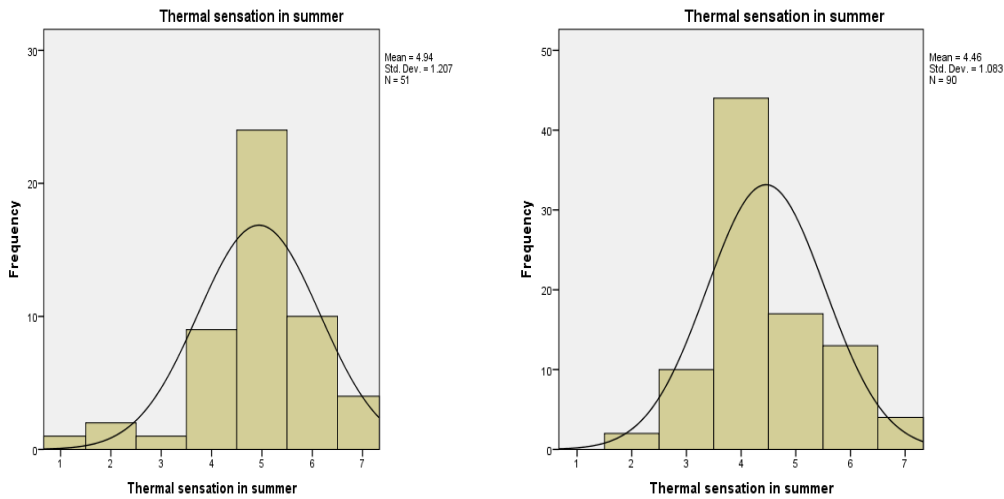

Figure 14: Distribution of thermal sensation votes at Bridport (left) and Oxley Park (right) in the summer (1= cold, to 7= hot)

The mean distribution of thermal sensation votes in the winter showed a drift towards ‘neutral’ with more than 87% responses indicating ‘slightly cool’, ‘neutral’ and ‘slightly warm’. Linking the results with those of the post occupancy surveys suggested that 75% of the occupants at Oxley Woods are also generally satisfied with how they feel in the winter (Figure 15).

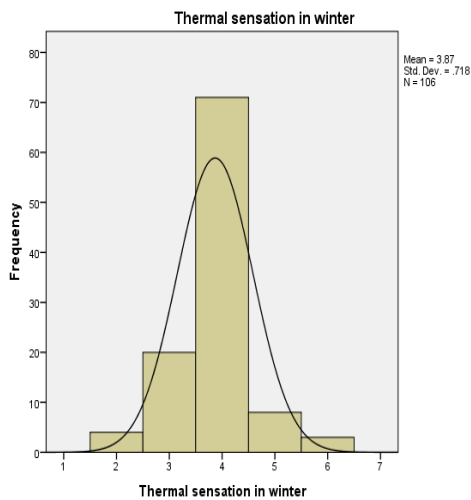

Figure 15: Distribution of thermal sensation votes at Oxley Woods in the winter (1= cold, to 7= hot)

Table 3: Mean responses for thermal sensation (from 1= cold, to 7= hot) and thermal preference in the summer and the winter (from 1=much cooler to 5=much warmer) from the comfort surveys

	Thermal sensation		Thermal preference	
	summer	winter	summer	Winter
Bridport	4.94	-	2.41	-
Oxley Woods	4.46	3.87	2.87	3.14

The responses from the summer surveys show that the occupants usually preferred to be ‘cooler’. The mean distribution of votes indicate that more than half of the responses at the case studies preferred to be ‘cooler’ with a drift towards ‘no change’ at Oxley Woods (Figure 16). In the winter, the results were rather different at Oxley Woods with well over 84% preferring no change to the thermal environment (Figure 17). The results indicate that there is an agreement with the feelings of comfort experienced by the occupants and the preference for temperature in the summer and winter (table 3).

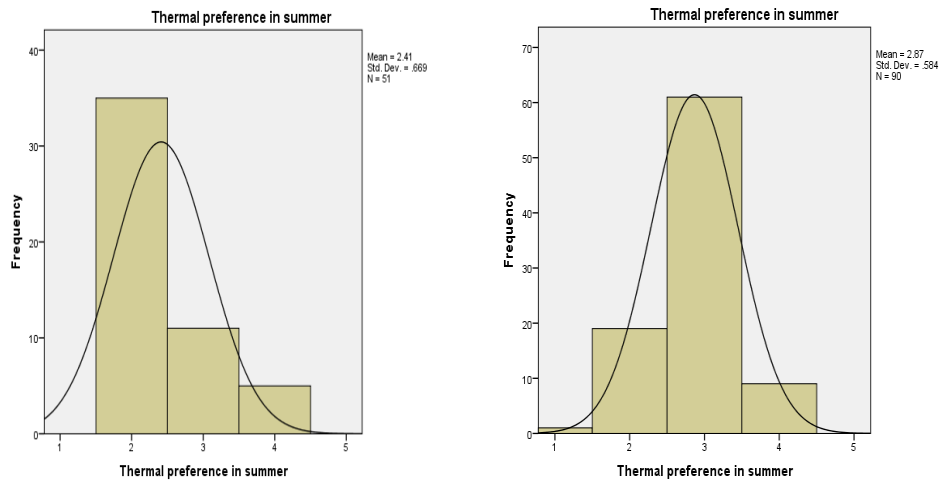

Figure 16: Distribution of thermal preference votes at Bridport (left) and Oxley Woods (right) in the summer (from 1- much cooler to 5- much warmer)

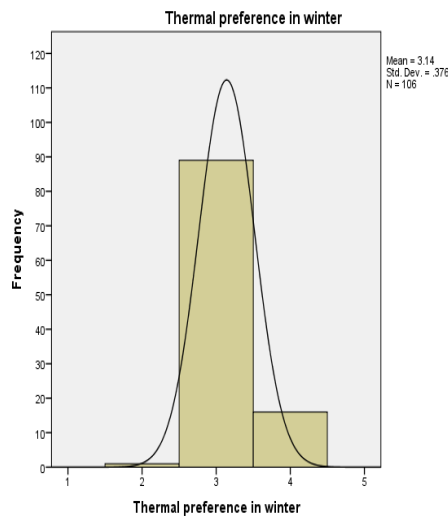

Figure 17: Distribution of thermal preference votes at Oxley Woods in the winter

6.0 Overheating analysis

6.1 Analysis of the overheating at Oxley Woods, using the static CIBSE criteria

Figure 18 illustrates the high percentage of hours that exceeded 25°C and 28°C for all the living areas and figure 19 shows the percentage of hours above 24°C and 26°C for all the bedrooms. The analysis suggested that 100% of the living areas monitored were above 25°C more than 10% of the time, 50% of the living areas exceeded 25°C more than 20% of the time and 25% of the living areas exceeded 25°C for more than 30% of the time. The analysis also suggests that 80% of the bedrooms exceeded 24°C more than 10% of the time. The results

indicate that many of the monitored spaces recorded temperatures that exceed the thresholds of moderately warm overheating risk.

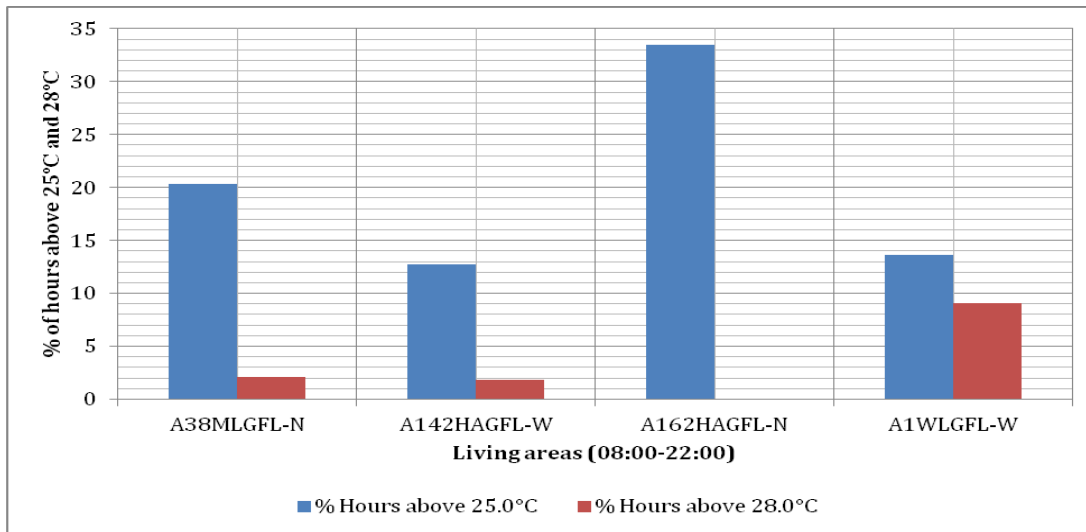

Figure 18: Monitored temperatures and overheating risk criteria, free-running living areas at Oxley Woods

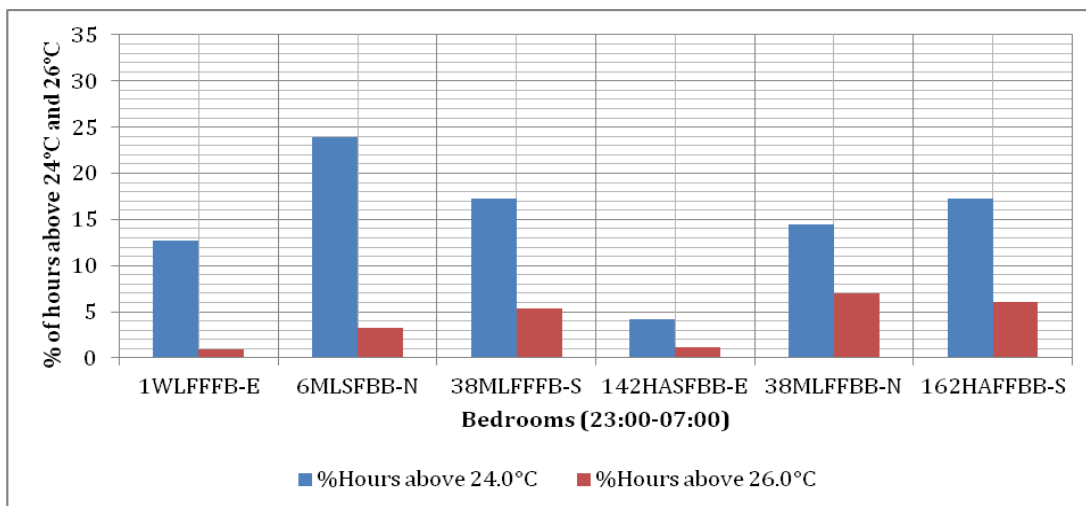

Figure 19: Monitored temperatures and overheating risk criteria, free-running bedrooms at Oxley Woods

Considering all the eight living rooms monitored at the case studies from 08:00-22:00, four living rooms (that is, 50%) are above the 5%/25°C mark of moderately warm overheating and well above 70% when taking into consideration the evening time from 18:00-22:00 as the occupants are expected to occupy the house at the evening period generating more internal heat. Looking at the 1%/28°C indicator of extremely hot summertime, three of the houses (that is, 43%) were above the mark most of the time. Taking into consideration the eight bedrooms monitored at the case studies at the evening time from 23:00 to 07:00, 56% above the 5%/24°C and 67% above the 1%/26°C indicator. The results indicated that bedrooms in the houses at Oxley Woods are warmer than the bedrooms at Bridport, which is a block of flats.

The results indicated that the temperature in the living rooms at Oxley Woods rose above 25°C for 20% and 28°C for 3.3% of the monitoring period (Figure 18). At Bridport, the temperature exceeded 25°C for 1% and none recorded above 28°C as the weather conditions during the time of the surveys were wet and mild.

The results also suggest slight differences in the design can also influence the resulting overheating. E.g. floor to ceiling heights at Bridport are 300mm higher than at Oxley Woods and with bigger openings. However, further investigation will be required to evaluate the effect of these differences in influencing the potential of summertime overheating in dwellings.

6.2 Analysis of the overheating at Bridport and Oxley Woods, using the dynamic adaptive comfort criteria

Overheating was also examined using the adaptive criteria, Cat. II ‘normal level of expectation’. Comparing the monitored hourly temperatures with the running mean of the daily mean outdoor temperature (T_{rm}) suggested an anticipated drift towards much warmer internal temperatures as T_{rm} increased (Figures 20 and 21). The variations in indoor temperatures for a certain T_{rm} value differ from one household to another. During the monitoring period in the summer, some monitored spaces (A1WLFFFB, A6MLSFBB, A38MLFFFB, A142HASFBB, A1WLGFL, A38MLFFBB, A162HAFFBB) were above the Cat. III ‘acceptable, moderate level of expectation’ ($T_{rm} > 18^{\circ}\text{C}$) mark which indicated extreme cases of high temperatures above the recommended Cat. II mark (Figure 20). Other houses monitored were observed to be cooler with minimum difference in the everyday temperatures. Some houses were observed to be regularly lower than the Cat. II indicator, in mild weather (Figure 21). At Bridport, the adaptive comfort criteria suggested that some of the monitored flats were within the Cat. II indicator (Figure 22).

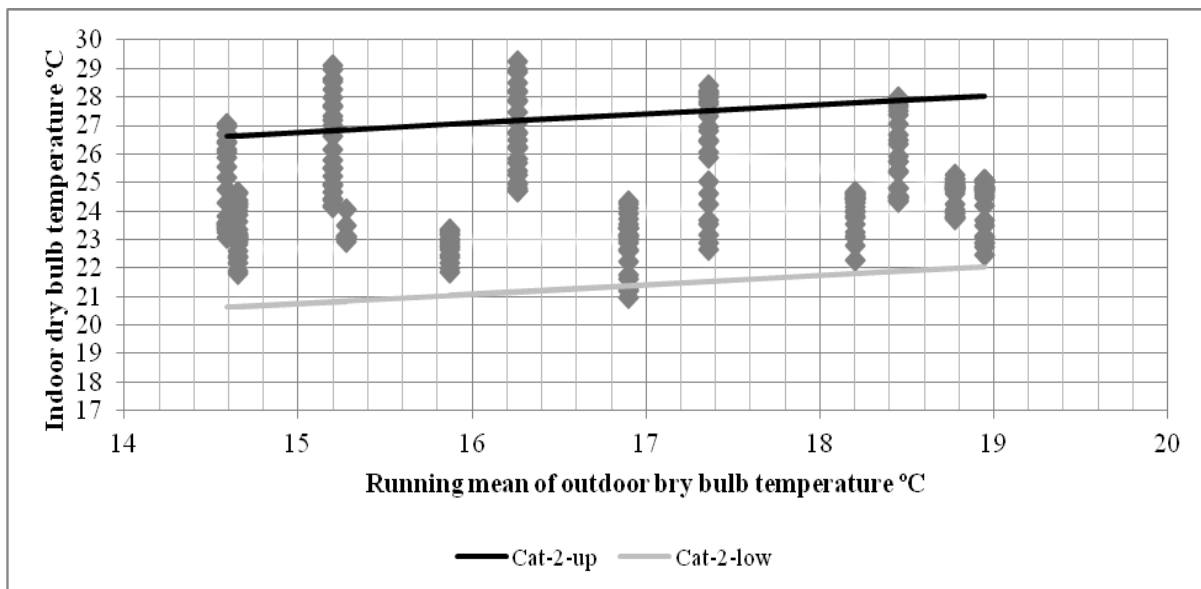

Figure 20: Temperatures recorded in A6MLSFBB suggesting warm discomfort, compared to the BSEN15251 thresholds

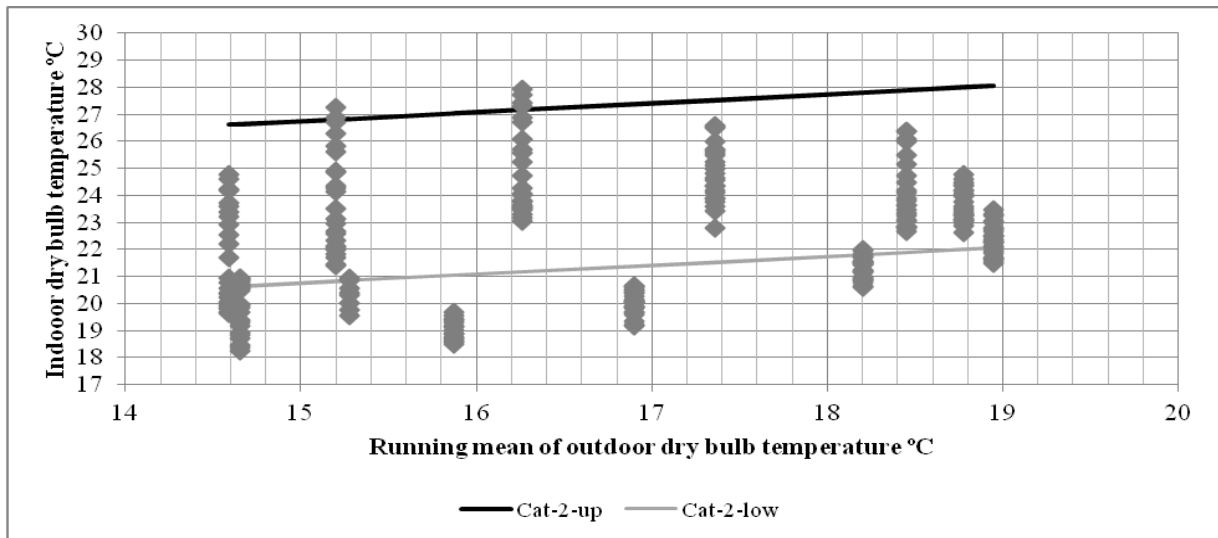

Figure 21: Temperatures recorded in A142HAGFL suggesting cold discomfort, compared to the BSEN15251 thresholds

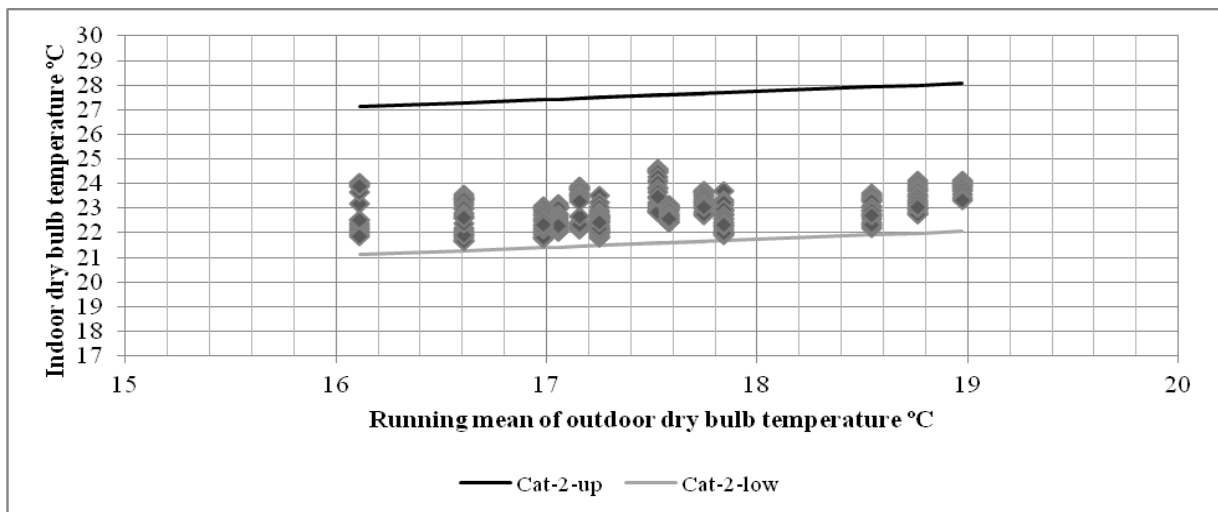

Figure 22: Temperatures recorded in FL1GFL suggesting no discomfort, compared to the BSEN15251 thresholds

Taking into consideration Cat. II threshold 'normal level of expectation', there was one living area and six bedrooms (42%) that exceeded 5% of hours above the Cat. II upper threshold, but six living rooms (35%) and four bedrooms (24%) exceeded 5% of hours below the Cat. II lower marker (Figures 23 and 24). The analysis suggests that there is significant overheating potential in prefabricated timber houses.

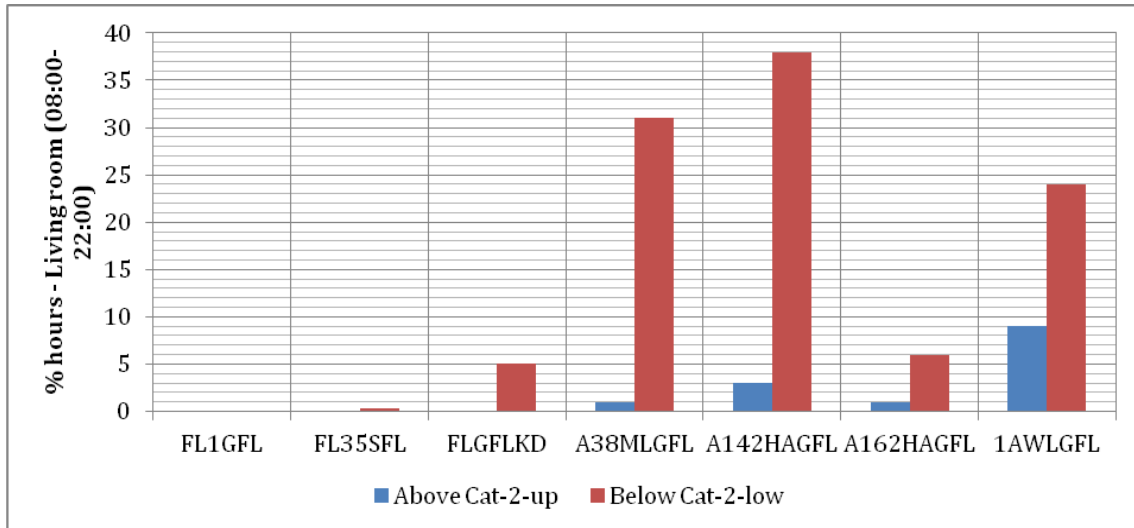

Figure 23: Percentage of hours of living room temperatures in BSEN15251 Cat. II thermal comfort category

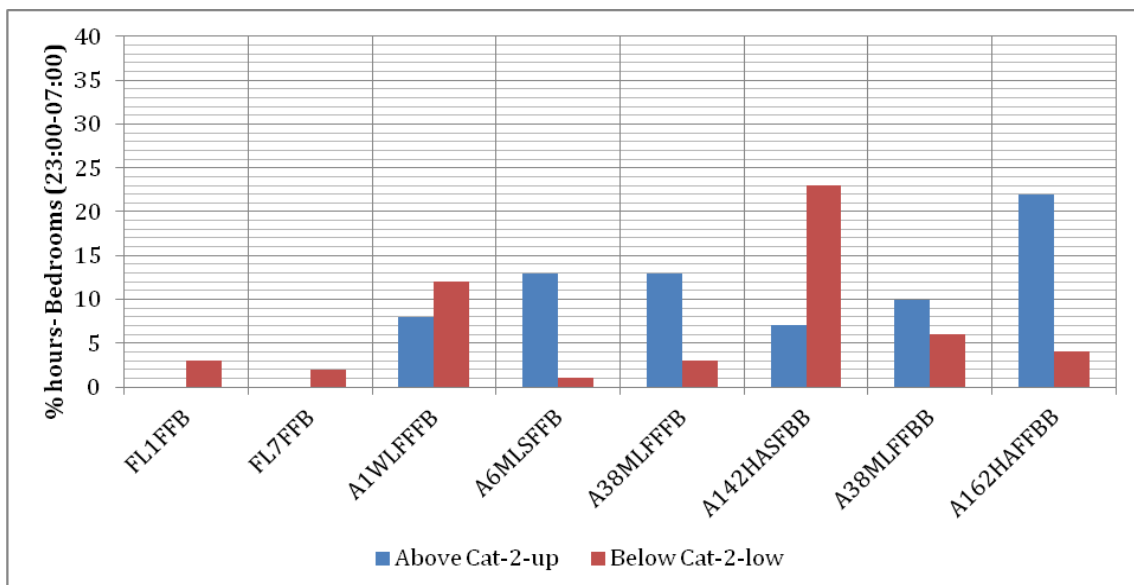

Figure 24: Percentage of hours of bedroom temperatures in BSEN15251 Cat. II thermal comfort category

7.0 Conclusions

The paper presented the results from post occupancy evaluations, indoor monitoring and thermal comfort surveys from different prefabricated timber houses with low thermal mass, in the south-east of the UK.

The post-occupancy evaluations indicate that over 70% of the occupants report on the warm and hot part of the scale with most of them generally 'not satisfied' with the thermal conditions of their indoor environment, which suggests that overheating occurs.

The comfort surveys provided a different picture, as 75% and 38% responses feel 'warm' at Bridport and Oxley Woods respectively in the summer. Further analysis shows that over 90% of Oxley residents owned the house and have been living in the house for more than two years which could suggest they have a better understanding of controlling and adjusting the internal environment of the house, increasing their adaptive capacity.

Taking into consideration the static CIBSE criteria, overheating appears to be more prominent at Oxley Wood rather than Bridport. Summer temperatures in the living rooms rose above 25°C for 20% and 28°C for 3.3% at Oxley Woods, while at Bridport exceeded 25°C for 1% and none above 28°C. It is possible that such differences are attributed to design related parameters, such as higher floor-to-ceiling heights, wider openings, etc., but such comparison could not be made directly, due to the lower external temperatures during the monitoring of the Bridport.

Evaluated against the adaptive thermal comfort criteria, of the eight living areas monitored, well over 50% indicated moderately warm overheating risk for the Cat. II upper threshold as shown by the 5%/25°C and 1%/28°C mark applied over the period of monitoring. Applying 1%/26°C indicator in the night period from 23:00-07:00 to the eight bedrooms monitored, the results suggest that well over 67% were at extreme overheating risk.

The results consistently suggest that overheating occurs in UK timber houses, which appears to be attributed to the high levels of insulation and lack of thermal mass. This suggests that excess heat gains cannot be easily dissipated and contribute to the increase of the internal temperatures and consequently overheating in the space.

Acknowledgements

This study has been funded by a Research Scholarship from the University of Kent. We are grateful to the residents of the case studies, particularly those who allowed us access for the monitoring and for their cooperation throughout the period of the surveys. We also appreciate the assistance from the London Metropolitan Housing Trust, Rogers Stirk Harbour Architects and the London Borough of Hackney for their support. The authors are also grateful to Professor Gerry Adler for the insightful discussions on housing.

References

- Beizaee, A., Lomas, K. J. & Firth, S. K. (2013), 'National survey of summertime temperatures and overheating risk in English homes'. *Building and Environment*, 65, pp 1-17
- British Standards Institute (BSI, 2008), 'Indoor environmental input parameters for design and assessment of energy performance of building addressing indoor air quality, thermal environment, lighting and acoustics', British Standard BSEN15251, London
- CIBSE (2006), 'Guide A, Environmental Design', 7th Edition, Chartered Institution of Building Services Engineers, London, UK
- CIBSE (2010), 'How to manage overheating in buildings: a practical guide to improving summertime comfort in buildings'. CIBSE Knowledge Series, The Chartered Institution of Building Service Engineers, London
- Cohen, R. R., Munro, D. K. & Ruyssvelt, P. (1993), 'Overheating criteria for non-air conditioned buildings'. In *Proceedings of the CIBSE National Conference*, UK
- Eppel H. & Lomas, K. J. (1992), 'Comparison of alternative criteria for assessing overheating in buildings'. BRE Support Contract Report 12, Leicester Polytechnic (DeMontfort University), School of the Built Environment, Leicester, UK

- Firth, S. K. & Wright, A. J. (2008), 'Investigating the thermal characteristics of English dwellings: Summer temperatures'. In Proceedings of Windsor Conference, UK, 27-29 July. London: Network for Comfort and Energy Use in Buildings
- Gupta, R. & Gregg, M. (2012), 'Adapting UK suburban homes for a warming climate'. In Proceedings of 7th Windsor Conference, UK, 12-15 April. London: Network for Comfort and Energy Use in Buildings
- Holmes, M. & Hacker, J. (2008), 'The problem of the summertime overheating prediction'. In Proceedings of Conference on Air Conditioning and the Low Carbon Cooling Challenge, Cumberland Lodge, Windsor, UK, 27-29 July. London: NCEUB
- Hajat, S., Kotvas, R. S., Atkinson, R. W. & Haines, A. (2002), 'Impact of hot temperatures on death in London: a time series approach'. *Journal of Epidemiology and Community Health*, 56(5), pp 367-372
- Jowett, O. (2011), 'The thermal behaviour of cross-laminated timber (CLT) construction and its resilience to summertime overheating'. In Proceedings of the 27th International Conference on Passive and Low Energy Architecture (PLEA) in Louvain-la-Neure, Belgium, 13-15 July
- Lomas, K. J. & Kane, T. (2012), 'Summertime temperatures in 282 UK homes: thermal comfort and overheating risk'. In Proceedings of 7th Windsor Conference, UK 12-15 April, London: Network for Comfort and Energy Use in Buildings
- Lomas, K. J. & Kane, T. (2013), 'Summertime temperatures and thermal comfort in UK homes'. *Building Research & Information*, 41(3), pp 259-280
- Mlakar, J. & Strancar, J. (2011), 'Overheating in residential passive house'. *Energy and Buildings*, 43(6), pp 1443-1451
- Nicol, J. F., Hacker, J., Spires, B. & Davies, H. (2009), 'Suggestion for new approach to overheating diagnostic'. *Building Research & Information*, 37(4), pp 348-357
- Nicol, J. F. & Roaf, S. (2005), 'Post-occupancy evaluation and field studies of thermal comfort'. *Building Research & Information* 33(4), pp 338-346
- Orme, M., Palmer, J. & Irving, S. (2003), 'Control of overheating in well-insulated housing'. CIBSE/ASHRAE Conference - Building Sustainability, 24-26 Sept
- Peacock, A. D., Jenkins, D. P. & Kane, D. (2010), 'Investigating the potential of overheating in UK dwellings as a consequence of extant climate change'. *Energy Policy*, 38(7), pp 3277-3288
- Porritt, S. M., Cropper, P. C., Shao, L. & Goodier, C. I. (2012), 'Ranking of interventions to reduce dwelling overheating during heat waves'. *Energy and Buildings*, 55, pp 16-27
- Rijal, H. B. & Stevenson, F. (2010), 'Thermal comfort in UK housing to avoid overheating: lessons from a 'Zero Carbon' case study'. In Proceedings of Windsor Conference, UK, 9-11 April, London: Network for Comfort and Energy Use in Buildings
- Wright, A. J., Young, A. N. & Natarajan, S. (2005), 'Dwelling temperatures and comfort during the August 2003 heat wave'. *Building Services Engineering Research & Technology*, 26(4), pp 285-300

Triumph in the Tropics? Surveying the thermal environment of the Queensland house 1905-1926

Daniel J. Ryan

The University of Sydney, Australia daniel.ryan@sydney.edu.au;

Abstract

While the desire for thermal control in our homes may today appear natural, its provision in the domestic sphere of early twentieth-century Australia was shaped by debates about regional development, household reform and racial acclimatisation. Contemporary publications by experts in tropical medicine highlight how thermal comfort research in Australia was intimately connected to the political objectives of white settlement in the tropical North. While outdoor work was seen to be safe for European men, the domestic thermal environment was considered a key impediment to the health and wellbeing of white Australian women. This paper critically examines three of the earliest surveys of the indoor thermal environment in Australia to establish how tropical medicine sought to understand domestic conditions of European settlers. It offers an insight into the early methods of thermal researchers and how the changing understanding of heat stress was politicised to promote reform of vernacular methods of construction.

Keywords: Environmental Possibilism, History of thermal comfort, Domestic thermal comfort, Tropical development, Settler Colonialism

1 Introduction

Thermal surveys of buildings are never simply about temperature or occupant satisfaction. Behind them lurk many assumptions about buildings and economic development, technology, nationalism and the agency of occupants. While today, vernacular buildings are commonly studied for their thermal performance, they are frequently justified as simply a means to validate traditional building techniques so that their principles may be applied to contemporary practice (Dili et al., 2010, Singh. et al., 2010, Cantin et al., 2010). Though many of these investigations can trace their origins back to the work of Otto Koenigsberger and his colleagues (Koenigsberger et al., 1974), traditional forms of construction have not always been held in such high regard.

Systematic study in Australia of the indoor thermal environment emerged in Queensland in 1913 with the recognition of the welfare of the servantless European housewife as a key obstacle to White settlement of Tropical Australia. While many of the commonly-accepted arguments against White Australian men working in the tropics had been successfully refuted, the welfare of women in the tropics became a source of national anxiety and the focus of expert scrutiny (Henningham 2011). Women were seen to be affected by tropical conditions more than men due to poor housing and the effects of being confined indoors without any possibility of domestic help (Anon., 1912, Anon., 1919). In many cases, the poor

construction of the house was highlighted, with corrugated iron held up as a symbol of all that was wrong with vernacular construction at the time (Anon., 1913d).

Although these early studies were premised on the improvement of women's welfare, they ended up being promoted by experts like Sir Raphael Cilento, the director of the Australian Institute of Tropical Medicine in Townsville, as both a covert means to promote lifestyle reform in rural areas and to refute international claims by environmental determinists that the tropical climate was causing the long-term degeneration of Europeans. These studies occurred at a time where the discourse of tropical architecture in the British Empire was most concerned with sanitary and housing reform to improve the level of economic production in the Tropics by minimising worker's illnesses (Chang and King, 2011 pp.295-296). Within much of the tropical world this entailed a metropolitan interest in the housing conditions of indigenous labourers. However, the promotion of sanitary and housing reform in Queensland provides a contrasting case study as there was little interest shown in the welfare of the Aboriginal population. The enforcement of the White Australia policy from 1901 saw the promotion of the tropical part of the state as a racial experiment in agricultural production by a White-only population. However the popular consensus among older experts still held that Europeans were out of place in the tropics as the climate impeded long term settlement (Anderson, 2002 pp85-86). Reformers therefore sought to examine the conditions in Northern Australia in which the average settler lived.

This paper examines three surveys conducted between 1913 and 1924 to show how the discourse on thermal comfort during this time produced a new subject, the servantless European housewife. It highlights how the studies sought to provide credible evidence of the effects of particular construction methods on internal temperatures and expanded in scope to survey the technology and layout of rural kitchens against the Australian Institute of Tropical Medicine's hygienic ideal. The last study was published as one of the principle sections of Raphael Cilento's government publication, 'The White Man in the Tropics' and was his main source of evidence that white men and women could live in the tropics and expect the same if not better health outcomes than those in more temperate lands (Cilento, 1925). Yet it also highlighted that many families lived in conditions that were far from ideal, serving as a precursor for Cilento and others to argue for housing reform in the state.

While 'whiteness' may today wield its power through its "unmarked, unnamed status" (Frankenburg, 1993 p.6), in Australia, as Alison Bashford has pointed out, it was explicitly studied, monitored and written about in the early decades of the twentieth century (Bashford, 2000). As both Anderson and Bashford have outlined, tropical medicine was instrumental in the governance of whiteness (Bashford, 2000, Anderson, 2002). Although previously white bodies were seen to be out of place and unfit for warm climates, by the early twentieth century, Australian experts in the new field of tropical medicine dismissed such a position, blaming disease not climate for all tropical ills (Anderson, 2002). Indeed the close connection between ideals of racial and medical purity were reflected in the many references made between the Immigration Restriction Act of 1901 (the 'White Australia Policy') and the Quarantine Act that followed it in 1908 (Bashford, 1998). Australian doctors were convinced that Europeans could survive in the tropics only by avoiding contact with disease. Increasingly they portrayed non-white labourers as disease carriers and argued for the preservation of white immunity through the deportation of Pacific Islanders and immigration restrictions on Chinese labourers (Anderson, 2002 p.111).

This attempt to keep Australia 'pure', justified on medical grounds, only exacerbated the decline in the availability of servants in the country. Along with the impact of the White Australia policy, Higman argues that the decline in migrants as a source of domestic labour was due to competition for servants between Britain and Australia along with increased rigour in the selection process for servants. The lack of servants, particularly in the tropics, was seen as one of the byproducts of the White Australia policy, and even despite continuing demand for them, into the 1920's the government remained unmoved to repeal legislation to widen the labour force to include Chinese or Indian migrants (Douglas, 1977 p.91). Nor were Aboriginal women encouraged as a source of labour. The secretary of the Department of External Affairs, Atlee Hunt, considered their employment contrary to the ethos of the White Australia policy:

If, however, existing systems are to continue and be extended—if the natives are to be gradually drawn from their distant fastnesses and encouraged to work as servants of the whites—then are we not encouraging a state of things that it is one of the objects of the white Australia policy to prevent? (Hunt, 1915 p.50)

Therefore unlike the families of colonial officials in Singapore or Sri Lanka at this time, white women in Tropical Australia were unlikely to have assistance with housework.

2 First Investigations 1913

During the 1910's a perception grew that white women suffered from the tropical climate more than men on account of the poor construction of dwellings, their confinement indoors and the long hours of labour they were expected to perform without assistance. The Commonwealth meteorologist, H.A.Hunt, painted a dramatic picture of typical conditions. "These unfortunate souls, cramped up in little iron boxes over a hot stove", Hunt claimed, "are rarely healthy looking. They suffer from anaemia and lassitude....There is very little doubt that the anemic look is caused by the conditions in which they live and work" (Anon., 1913a). Yet such pronouncements were not backed up by any scientific study.

Hunt and medical academics such as James Barrett and W.A. Osborne at the University of Melbourne were interested in the effect of humidity on the health of Europeans in the tropics. They were familiar with the work of J.S. Haldane, through their colleague Dr. Harvey Sutton who had worked under Haldane at Oxford (Osborne, 1909). A decade earlier, J.S. Haldane had proposed that the wet-bulb temperature was a better indicator of heat stress than air temperature alone. Haldane's classic experiments on himself in mines and climate chambers had shown that high wet bulb temperatures had a bearing on productivity and he recommended an upper limit of 78°F or 25.5°C for people engaged in continuous hard work and 88°F or 31°C as the maximum safe temperature for people at rest (Haldane, 1905). He recognized that similar conditions to the tropics could be found in man-made environments as he noted that there were "many industrial occupations in which men or women have to work daily in very warm air"(Haldane, 1905 p.494). The tropics had come home to roost in England.

Yet if even tropical conditions could be found in industrial England, then how safe were working conditions in ordinary homes in Queensland? Haldane's pronouncements on the upper limits of temperature for work greatly concerned Walter Osborne and James Barrett who feared that parts of the tropics might prove unsafe for work (Barrett, 1910). However they could not be sure which parts of the tropics were safe as no maps existed showing wet-

bulb isotherms for Australia (Barrett, 1910). Osborne and Barrett were searching for Australia's thermal frontier.

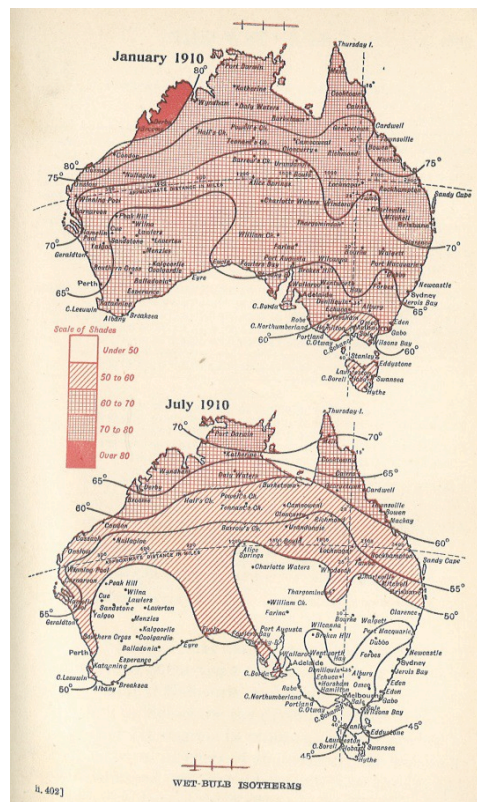

Figure 1. Wet Bulb Isotherms (Barrett, 1918 p.402)

The Commonwealth meteorologist H.A. Hunt responded to Osborne and Barrett's pleas, producing a map with wet bulb isotherms in 1910 (Figure 1). It indicated that Australia's tropical climate was safer than thought, with no parts of the country where the wet bulb temperature was in Haldane's danger area of 88°F or 31°C (Dew, 1913). While Barrett was happy about this, like Hunt, he believed that the poor appearance of many tropical women had an environmental cause. He blamed this on the neglect of climatic 'precautions' in many residences in Queensland, lambasting the inappropriate adoption of Melbourne housing models which he believed explained why women rather than men suffered more in the tropics. Though doctors sought to preserve the biological heritage of Europeans in the tropics, to Barrett and others their cultural heritage was an impediment to mass settlement. "In the tropics", Barrett lamented, "the white man clings tenaciously to his customs. His houses, his dress, his habits and even his food are to a great extent, constructed and arranged on the European model" (Barrett, 1910).

Of particular concern was the use of galvanised iron, a material that had been popularised, according to the historian Miles Lewis, in the late nineteenth century in rural Australia on account of its economy, weather-tightness and the purity of the water that could be obtained from it (Lewis, n.d.). However, Osborne and Barrett were less enthusiastic about the material.

Following on from mapping Australian wet-bulb isotherms, they urged the Commonwealth Meteorologist H.A. Hunt to “investigate the conditions under which women labor in the Northern Territory and Northern Queensland while performing their duties”(Anon., 1913b).

The design of the experiment was straightforward with wet-bulb thermometer readings to be taken twice a day, inside and outside houses in Darwin, Thursday Island and Townsville for a twelve month period. An article in *the Northern Miner* newspaper summarised the methodology and results:

The readings were taken twice daily in the open air and in the kitchen of a well-constructed house at Port Darwin. During the month of July the mean outside wet-bulb temperatures at 9 o'clock in the morning and at 3 o'clock in the afternoon were respectively 62.6 degrees and 68.8 degrees Fahrenheit. Inside the house, at the same hours, the thermometer registered 72.4 degrees and 90.2 degrees respectively (Anon., 1913b).

Hunt's results were significant. Not only had he clearly demonstrated that houses were warmer inside compared to outside conditions but more importantly that kitchens were dangerously hot. At three o'clock the wet-bulb temperature in the kitchen was over 2°F (1.2°C) greater than Haldane's recommended maximum safe temperature for people at rest. It didn't matter that only three houses were tested. Experts now had the evidence to condemn tropical housing as dangerous to women's health.

Although James Barrett presented his findings to politicians at the State Parliament house in late 1913, little appears to have been done about this (Anon., 1913c). For one settler it was clear from the findings that Europeans should not work in the tropics at all, while for Barrett, the problem was that few researchers sought practical solutions to their findings (Anon., 1914a, Barrett, 1914). Barrett and Hunt themselves argued that the Japanese house, with thin walls, open to the breeze was a much better solution for European housing in the tropics. However few people wanted to radically change their habits. As a contemporaneous article in *Punch* magazine noted: “not even an architect can force upon the public a style of house it does not want, and the Australian public has not hitherto wanted anything but the conventional and humdrum” (Anon., 1914b).

3 Matching Climate with Construction Methods

It was only with the formation of the Queensland Country Women's Association (QCWA) in 1922 that there was renewed interest in the rural housing conditions of European women. The association acted as a lobby group looking to improve the welfare of rural women and initially was an active promoter of research on domestic living conditions. There was a whole session devoted to “The Housing Problem” at their inaugural conference in Brisbane in July 1922. Among the speakers was the land surveyor Walter Wynne Williams who lectured about housing conditions in Tropical North Australia (MacFarlane, 1922, Anon., 1922b).

Williams sought to undertake a thermal survey of housing in Northern Queensland (Williams, 1922a). The objective was not simply to record the temperature of the houses but to be able “to illustrate to the public the considerable differences there must be between some of these houses”(Williams, 1922a). He was interested in finding out the effect that building construction had on the thermal range in houses in summertime in tropical Queensland. Williams had been spurred on to pursue the study after his lecture to the QCWA who

endorsed his proposal with a resolution to help him obtain the necessary equipment to carry out the study (Anon., 1922a, Williams, 1922a).

He suggested a survey of a range of buildings of different materials in both the town of Cloncurry and in 'distance stations' – large farmholdings in the interior where houses were made of stone and pisé construction. Cloncurry is located in the arid interior of North West Queensland and noted for its extreme climate. However it was not the external climate but the high temperatures of houses and the variation within buildings that most concerned Walter Wynne Williams. In the homesteads in the hinterland around Cloncurry such as at Devoncourt Station, Williams noted that there were marked variations in temperature between the ground floor of the house and the external upper floor balcony: "The reading in the lower part of the house was 95 degrees and under the naked iron the shaded , verandah upstairs the reading was 110 degrees"(Williams, 1922b p.1). Other homesteads he'd visited such as at Lake Nash registered temperatures of 117°F (47.2°C) on the verandah.

Although limiting the survey to recording just twelve buildings over a week in summer, Williams considered this adequate to obtain sufficient data that could "disclose some very startling comparisons"(Williams, 1922a p.1). Part of Williams' argument for the necessity of the survey was to make a case against the use of galvanised steel construction. Though he acknowledged that poorly designed ventilation was a greater problem than the steel itself, this did not stop him from laying most blame on the effects of specific construction materials rather than particular design strategies. Like Hunt ten years earlier, his mind was made up, the vernacular needed reform and only temperature measurements would mobilise change.

For Williams, the construction and ventilation of the verandah, the default solution for European housing in the tropics, had not been considered enough. As most verandahs he encountered were of galvanised iron and without a ceiling, temperatures were "10 to 15 degrees above the shade air temperature"(Williams, 1922b p.1). Williams took issue with the standard forms of roof ventilators and ceiling vents which he considered a 'farce'. His statements challenge the then- prevalent view that verandahs and ventilators were sufficient to provide relief in a hot climate. Instead, he cited a "weird looking little residence" built by a tinsmith as the only house in Cloncurry that stayed cool in summer. It challenged the popular thinking about building in the tropics as it was made of galvanised iron and had no verandah on its western façade. Its secret, according to Williams, was the system of ventilation.

Though Williams could see the limitations of accepted construction methods, he felt that "without some scientific data it is impossible to lay a case before the public or before any Society"(Williams, 1922b p.3). Williams did not believe that he could make any credible statements to either the public or learned societies, without recourse to temperature measurements. He aimed to "be able to produce some undisputed data illustrating the danger of our unventilated iron shacks for the public to think about"(Williams, 1922b p.4).

For that he sought the Chief Quarantine Officer General, J.S.C. Elkington's expertise and equipment. Elkington viewed Williams proposal as an opportunity to provide assistance to the new director of the Australian Institute of Tropical Medicine, Raphael Cilento and requested Cilento to review the proposal with him (Elkington, 1922b) . Three months later, having commenced his new position in Townsville, Cilento followed up with Wynne Williams, asking about his ideas on housing in the tropics (Cilento, 1922). Wynne Williams' letters to Cilento are important as they reveal the faith placed in science by both professionals and landowners to make life bearable in a climate many thought was unnatural for Europeans. They also highlight how the thermal conditions of the domestic interior, and more specifically the 'plight of the housewife' became a cause for housing reform.

Williams wanted to survey both urban and rural buildings of different construction methods. Ideally he wished to carry out the survey between September and December when "the heat is great and constant" and before the onset of storms. He outlined his methodology as follows:

What I intended to do was to experiment with a few thermometers, wet and dry bulb, in my own house to arrive at the variations in the various parts of the building, and from this data be guided as to suitable places to suspend the thermometers in the various buildings. I would then choose a few buildings, good bad and indifferent, and for the course of a week or so keep the maximum and minimum charts. These temperatures could then be compared with the wet and dry bulb readings of the thermometers in the Post Office louvred box. After collecting sufficient evidence in Cloncurry I would take the thermometers to some of the outback stations where there are stone and pise' houses, place one in a louvred box and the others in the different station buildings (Williams, 1922b).

Just who could be trusted to undertake thermal surveys of buildings at this time is of interest. The Chief Quarantine Officer, JSC Elkington, saw in Williams' proposal, the potential to get a wider range of climate data for the institute(Elkington, 1922a). He initially requested the names of potential volunteers to help with such work. Williams however dismissed his request for as impractical, reasoning that those in poorer dwellings would not be interested and were unreliable(Williams, 1922a). Though Williams himself later admitted that he did not "profess to be a scientist", he looked to Cilento for direction and felt that "my early scientific training will probably assist me in understanding and carrying out your instructions"(Williams, 1922b p.4). Williams and his staff could carry out the survey of urban residences while the managers and bookkeepers on the rural stations could be relied on to chart the temperatures of the pise and stone buildings. They may not have been trained in science but they were reliable and respected.

Cilento offered minimal advice to Williams as to how best to actually carry out the surveys, using the letters more to disseminate the latest thinking within tropical medicine on housing design. He corrected Williams' reliance on air temperature and humidity data as evidence of discomfort by claiming that 'heat stagnation' was the primary cause of discomfort. By way of illustration Cilento noted that "if you put a man in a closed respiration chamber where the air is absolutely still, it becomes unbearable between 80°F and 90°F.If, in the same temperature, a fan is turned on in the small chamber, it is fairly cool and not very uncomfortable"(Cilento, 1922). Though Cilento claimed to have made some inquiries about how best to carry out the study, he never followed up on this advice with Williams.

In the end Williams was left to purchase the thermometers for himself, by which time he had moved to the outback town of Longreach in Central West Queensland. He wrote to Cilento a year later in November 1923 informing him of his plans and that he was about to carry out the survey (Williams, 1923). Williams' proposed method was largely the same as he had elaborated the previous year, only now he had narrowed taking measurements to just the kitchen and living room, at a point in the centre of the room, six feet from the ground. The central positioning of instruments was to minimise the influence of draughts, he claimed, while the high location of the thermometers may have been influenced by Cilento's previous observation that "the chief cause of discomfort in either a ceilinged or unceilinged room is a dead cushion of hot air that starts about six feet up and reaches to the to the roof" (Cilento, 1922). Cilento himself approved of Williams' methodology and requested he send on the results.

Unfortunately no documentation exists of Williams' findings and it would not be another twenty five years before another attempt was made at observing internal temperatures for various construction methods in a range of climate zones in Australia (Drysdale, 1947). Instead it was the presence or absence of certain features that Raphael Cilento and his colleagues used to indicate the level of climatic adaptation of a building. Just as Williams was refining his methods, Cilento was contacted by the newly formed Queensland Country Women's Association (Q.C.W.A.) to produce pamphlets on family health. However he sought to undertake a 'sociological survey' of Northern Queensland and use the branches of the QCWA to facilitate the inquiry by both spreading propaganda for the institute and offsetting travel costs by hosting a researcher for lectures.

4 Surveying the Servantless House

The QCWA acted as the catalyst for both Williams and the Australian Institute of Tropical Medicine's studies on housing conditions. It was after speaking at their first conference in 1922 that Williams decided to undertake a thermal survey of different domestic construction methods and it was the QCWA who gave Raphael Cilento the impetus to start a 'sociological unit' in 1923. Cilento turned their initial request into a much wider survey of living conditions in Northern Queensland. Strategically, he viewed the emergence of the QCWA as an opportunity to set an agenda for the QCWA and spread the influence of work of the Australian Institute of Tropical Medicine (AITM) to a much wider audience. As he noted in a private memo to the Directors of the Division of Tropical Hygiene in Brisbane:

It appears to me that this would be a magnificent opportunity to take advantage of a popular movement during the stages of its early and rapid spread, and to impose upon it a programme which might orientate the party towards the Institute and the Division, without identifying us in any sense with the Association other than as a benevolent mentor for this or any similar activity. (Cilento, 1923b)

It was Raphael Cilento's wife Phyllis who formed the bridge between the interests of the AITM and that of the QCWA. She was also a doctor and a keen advocate of improving the medical welfare of women. Though she was not attached directly to the AITM, she shared many of her husband's concerns about the reform of tropical lifestyles, lecturing to the Women's Club in Townsville on dress reform in March 1923 and at the QCWA's 1923 Northern conference in Charters Towers on 'Women in the Tropics' (Cilento, 1923a).

It was after her lecture that she obtained the support of the second conference of the QCWA, to approach the AITM to appoint:

a capable travelling female officer

1. To investigate and report on conditions affecting the well being of women resident in remote areas or living under unfavourable conditions.
2. To lecture and give demonstrations to these women on problems of tropical life.

(Anon., 1923)

While the QCWA had backed the proposed 'sociological survey' of rural women as a means to gain information on rural women's living conditions, the AITM used it as a pretext to survey the physical development of rural women and children. At the time, geographers such as Ellsworth Huntington, propagated the belief that the climatic environment affected the mental and physical development of races (Huntington, 1915). The long-term presence of Europeans in the tropics, it was feared would lead to their degeneration. The settlement of tropical Queensland to climatic determinists like Huntington and F. Griffith Taylor was a risky experiment, whose apparent success could only be explained by the 'fact' that it had a selected population. Even open air crusaders like Leonard Hill, the inventor of the katathermometer, were concerned: "the evidence seems to show that...in Queensland...the women leading an indoor life fade and become sterile" (Hill, 1921).

Though climate determined which towns were chosen to partake in the survey, the survey of houses themselves was limited to questions of sanitation and kitchen design. The kitchen layout itself was measured against the standard for residences in Quarantine stations set by the public works department and department of tropical hygiene, all of which were located along Queensland's coastal fringe. The female participants were not themselves systematically questioned about their own opinion of their housing conditions and nor did the survey instrument check for any design features that might be specific to the climate.

The survey had not set out to find examples of ideal conditions, but rather to study women living in the most difficult of circumstances. While the QCWA may have wished to use this to find out how bad conditions were to enable reform, in the end the survey gave another reason in favour of Europeans settling the tropics. Instead of arguing for housing reform, the AITM's physical measurements were used to show conclusively that Europeans could maintain their health in the tropics despite their environment.

Yet this is not to suggest that the thermal conditions of buildings were of little interest to the director of the Australian Institute of Tropical Medicine, Raphael Cilento. In fact, Cilento's advice to Williams formed the basis for his chapter on housing in the tropics in his seminal publication 'the White Man in the Tropics' (Cilento, 1925). In it he distinguished between two approaches to housing in the tropics, the bungalow for the 'wet tropics' and the Spanish courtyard house for the 'arid tropics'. Such binary distinctions would continue well into the 1970's with the Public Works Department continuing to label house types in tropical Australia based on only two types of climate – 'arid' or 'tropical'. It also demonstrates the engrained belief that housing in the tropics was principally a technical question of climatic design, not a socio-cultural one of lifestyle.

5 Conclusion

Systematic reform of thermal conditions of housing did not happen in Australia until well into the 1940's with the establishment of the Experimental Building Station and their program of model test huts in different parts of Australia. Cilento's repeated statement that the European population of Queensland were healthy despite the conditions gave little medical reasons to aim to improve the design of housing. A number of attempts at organising competitions for an 'ideal tropical house' failed and it was largely the post-war masterplanning of Darwin and the wish to redevelop war manufacturing to deploy lightweight, cheap, mass housing throughout Australia that gave renewed impetus to the systematic study of the thermal design of housing.

Reports on the sociological investigations of Queensland homes highlighted the perception among the wealthy that the thermal reform of the house was a matter for the poor, while also claiming that the poor themselves were not interested in attending her lectures (Gorman, 1925 p.18). In addition any change to the standard design of a house was perceived to be more expensive, something that neither landlords nor homeowners were willing to pay for.

Williams' methodology is not hugely different to today's residential thermal surveys with temperature and humidity readings taken roughly in the centre of a room and compared to local weather readings (De Dear et al., 2010). The difference is that temperature and humidity alone were used to indicate comfort, with no occupant surveys. In addition we can see that where today the objectives of thermal surveys are to reduce energy expenditure or carbon emissions, in 1923 the survey was designed with the objective of improving the wellbeing of women. Such an intention was not wholly benign, for at its core was the belief by Europeans that they had the right to settle anywhere in the world. The tropics were merely a thermal frontier that could be tamed with the correct technology.

References

- Anderson, W. 2002. *The Cultivation of Whiteness: Science, Health and Racial Destiny in Australia*, Melbourne, Melbourne University Press.
- Anon. 1912. Peopling the North - The Great Problem - Work for Scientists. *Sydney Morning Herald*, 21 December, p.19.
- Anon. 1913a. Anemic Women. Investigations in Northern Australia. *The Register*, 8 April, p.8.
- Anon. 1913b. North Queensland Tests - Readings in Houses. *The Northern Miner*, 26 November, p.5.
- Anon. 1913c. North Queensland Tests - Readings in Houses. *The Argus*, 19 November, p.15.
- Anon. 1913d. Women in the Tropics - Their Sad Lot - As described by one of them. *The Catholic Press*, 17 July, p.25.
- Anon. 1914a. Australia's Greatest Asset - The Northern Territory - An Outspoken settler. *Northern Territory Times and Gazette*, 22 January. Anon. 1914b. Rational Acclimatisation. *Punch*, p.12 March. Anon. 1919. White Slaves. *Cairns Post*, 19 July, p.4.
- Anon. 1922a. Best type of house for Northern Queensland - Women want to know. *The Sydney Stock and Station Journal*, 18 August, p.2.
- Anon. 1922b. Country Women's Conference *Brisbane Courier*, 8 August, p.19.

- Anon. 1923. Country Women - Northern Conference - Important Resolutions. *Morning Bulletin* 18 July, p.8.
- Barrett, J. W. 1910. White Men for the North - Problem of Colonisation - Plea for Research Work. *Cairns Post*, 04 October, p.7.
- Barrett, J. W. 1914. Application of Knowledge - the responsibility of students. *The Argus*, p.12.
- Barrett, J. W. 1918. *The Twin Ideals - An Educated Commonwealth*, London, H.K. Lewis & Co. Ltd.
- Bashford, A. 1998. Quarantine and the imagining of the Australian Nation. *Health*, 2, 387-402.
- Bashford, A. 2000. 'Is White Australia possible?' Race, colonialism and tropical medicine. *Ethnic and Racial Studies*, 23, 248-271.
- Cantin, R., Burgholzer, J., Guarracino, G., Moujalled, B., Tamelikecht, S. & Royet, B. G. 2010. Field assessment of thermal behaviour of historical dwellings in France. *Building and Environment*, 45, 473-484.
- Chang, J.-H. & King, A. D. 2011. Towards a genealogy of tropical architecture: Historical fragments of power-knowledge, built environment and climate in the British colonial territories. *Singapore Journal of Tropical Geography*, 32, 283-300.
- Cilento, P. 1923a. Women in the Tropics: Dr. Cilento's paper. *The Northern Miner*, 01 August p.3.
- Cilento, R. W. 1922. Letter to W. Wynne Williams, 4 December. *Australian Institute of Tropical Medicine papers*. Sydney: National Archives of Australia.
- Cilento, R. W. 1923b. Letter to the Directors, Division of Tropical Hygiene, Brisbane, 28 June. *Australian Institute of Tropical Medicine papers*. Sydney: National Archives of Australia.
- Cilento, R. W. 1925. The White Man in the Tropics with Especial Reference to Australia and its Dependencies. *Service Publication* Melbourne: Division of Tropical Hygiene.
- De Dear, R., Candido, C. & Parkinson, T. 2010. ARC Discovery Project –DP110105596 Field Survey of Residential Air Conditioning and Comfort in Australia. ARC.
- Dew, T. K. 1913. Australia's Northern Territory. *The North Western Courier*, 02 April.
- Dili, A. S., Naseer, M. A. & Zacharia Varghese, T. 2010. Validation of climate responsiveness of NE Indian Vernacular architecture. *Building and Environment*, 45, 2218-2230.
- Douglas, R. A. 1977. Dr Anton Breinl and the Australian Institute of Tropical Medicine Part 3. *Medical Journal of Australia*, 784-790.
- Drysdale, J. W. 1947. Climate and House Design: Summary of Investigations, 1945-1947. Sydney: Commonwealth Experimental Building Station.
- Elkington, J. S. C. 1922a. Letter to W. Wynne Williams, 25th August. *Australian Institute of Tropical Medicine papers*. Sydney: National Archives of Australia.
- Elkington, J. S. C. 1922b. Memo from Elkington to Raphael Cilento, 25 August *Australian Institute of Tropical Medicine papers*. Sydney: National Archives of Australia.
- Frankenburg, R. 1993. *White Women, Race Matters: The Social Construction of Whiteness*, Minneapolis, University of Minnesota Press.
- Gorman, A. 1925. Report on House to House Visitation Sociological Unit. Townsville: Australian Institute of Tropical Medicine.
- Haldane, J. S. 1905. The Influence of High Temperatures. No.1. *The Journal of Hygiene*, 5, 494-513.
- Hill, L. 1921. Notes on Tropical Climate and Health. In: Balfour, A. (ed.) *Notes on Housing and Health in the Tropics*. Port Moresby: Edward George Baker Government Printer.

- Hunt, A. 1915. The Northern Territory of Australia / memorandum by the Secretary, Department of External Affairs. In: Affairs, D. O. E. (ed.). Melbourne: Government Printer.
- Huntington, E. 1915. *Civilization & Climate*, New Haven, Yale University Press.
- Koenigsberger, O. H., Ingersol, T. G., Mayhew, A. & Szokolay, S. V. 1974. *Manual of Tropical Housing and Building: Volume 1. Climatic Design*, London, Longman.
- Lewis, M. n.d. Corrugated Iron. *Australian Building: A Cultural Investigation*. Melbourne: University of Melbourne.
- Macfarlane, C. A. May 20 1922. Letter to W.Wynne Williams, Lands Dept. Brisbane re: Country Women's Conference, May 20. *Correspondence re: the First Meeting of the QCWA*. Brisbane: Archives of the Queensland Country Women's Association.
- Osborne, W. A. 1909. Heat and Health. *The Argus*, 09 January, p.6.
- Singh., M. K., Sadhan Mahapatra & Atreya., S. K. 2010. Thermal performance study and evaluation of comfort temperatures in vernacular buildings of North-East India. *Building and Environment*, 45, 320-329.
- Williams, W. W. 1922a. Letter to J.S.C. Elkington, August 30. *Australian Institute of Tropical Medicine papers*. Sydney: National Archives of Australia.
- Williams, W. W. 1922b. Letter to Raphael Cilento, 6 December. *Australian Institute of Tropical Medicine papers*. Sydney: National Archives of Australia.
- Williams, W. W. 1923. Letter to Raphael Cilento, 30 November. *Australian Institute of Tropical Medicine papers*. Sydney: National Archives of Australia.

A Study of Thermal Mavericks in Australia

Lyrian Daniel¹, Terence Williamson¹, Veronica Soebarto¹, Dong Chen²

1 School of Architecture and Built Environment, the University of Adelaide, Australia,

2 CSIRO Ecosystem Sciences, Australia

Abstract

The research presented in this paper was conducted in order to test whether the thermal preferences of occupants in *low energy* houses are influenced by their environmental values. This was done through a thermal comfort study and Environmental Attitudes Inventory (EAI) of 40 *low energy* households located within two very different climates, cold temperate and hot humid, in Australia. The results show that the occupants of these dwellings considered conditions comfortable outside of the accepted adaptive thermal comfort limits and suggest that the conditions people find acceptable may be a function of their underlying environmental values. These results suggest that greater acknowledgement of atypical preferences in the mandatory assessment of building thermal performance is needed. The preliminary analysis presented in this paper is of the first six months of data collected in two cohorts of these ‘thermal maverick’ households (full data collection will cover approximately 12 months).

Keywords: thermal preference, adaptive model, environmental concern, residential buildings

1. Introduction

The field of thermal comfort research is in a transition period with many experts questioning the relationship between socio-cultural influences, and response to thermal environments (Nicol et al, 2012; Roaf et al, 2010; Chappells & Shove, 2005). This is particularly relevant in residential buildings where there is a more direct relationship between the occupants’ perception of their thermal environment and their opportunity for adaption. In an observation on the state of thermal comfort research, Hitchings (2009) suggests that studying the ‘*thermal mavericks ... could help make the strongest case against the further spread of ambient standards*’ (pg 92). The hypothesis underlying the research presented in this paper is that occupants of houses traditionally perceived to be *low energy*, are one such group of ‘thermal mavericks’, demonstrated by their expression of comfort at more extreme temperatures than predicted as acceptable by the widely used ASHRAE adaptive model of thermal comfort (ASHRAE, 2013). Furthermore, the paper presents the argument that this may be explained by the occupants’ level of environmental concern.

Despite interest in the literature for exploring the relationship between environmental attitudes and thermal preference (de Dear, 2004), no known studies have investigated this issue using both a psychological measure and comfort votes surveys. Australian studies that touch on parts of this topic include a qualitative investigation into the socio-cultural context of thermal comfort in a work place (Healey & Webster-Mannison, 2012); a quantitative comparison of the environmental attitudes and utility

use between eco-village and standard developments (O'Callaghan et al, 2012) and a post occupancy study of two office buildings supplemented with an environmental attitudes measure based on the New Environmental Paradigm (NEP) (Deuble & de Dear, 2012). The findings of all three of these studies support the continued investigation of this relationship; Healey & Webster-Mannison reporting on the importance of cultural and contextual factors on comfort-related adaptations; O'Callaghan et al (2012) demonstrating a correlation between pro-environmental attitudes and lower energy use; and Deuble & de Dear (2012) establishing a link between pro-environmental attitudes and the 'forgiveness factor'.

Building or buying a *low energy* home could be considered conspicuous 'environmental' consumption, where some aspect of the occupant's value system is displayed through the choices they make about built form, design and construction (Mazar & Zhong, 2010). A well-established example of this is dwellings incorporating earth construction walls (pise, adobe and compressed earth blocks). Occupants of this type of dwelling have previously been linked to higher levels of eco-centric attitudes and energy saving behaviours (Casey & Scott 2006; Daniel & Williamson, 2011); as well as considerable anecdotal evidence that occupants of earth buildings value a low-impact lifestyle (Rael, 2009; Easton, 1996; Dethier, 1981). A second, but almost more intrinsic, example is dwellings that are designed to be naturally ventilated, particularly in hot humid climates. While not as easy to define as earth buildings, these dwellings offer a similar expression of an individual's choice to 'experience the climate' not to rely on artificial cooling for comfort. The capacity for reduced energy consumption of this type of household is intuitive but also firmly supported by the literature (Kordjamshidi, 2011; Candido et al, 2010; Gill et al, 2010).

This research investigates these two distinct forms of housing in two very different climates; dwellings incorporating earth construction elements in a cold temperate climate (Melbourne, Australia), and naturally ventilated houses in a hot humid climate (Darwin, Australia). These perceived *low energy* dwellings represent a definable cohort for investigation, as it is likely that the occupants of these houses have higher levels of environmental concern than the general population; embodied in their very decision to live in these types of housing.

In Australia, the assessment of houses to demonstrate compliance with building code energy efficiency requirements relies on a computer simulation program which determines a "star rating". While the comfort range settings in this software, *AccuRate*, are not the same as suggested by the ASHRAE adaptive model, they are based on an understanding that acceptable conditions vary with the climate zone. These comfort settings determine heating and cooling energy loads which are the basis for the star rating and, ultimately, whether or not the design obtains building approval.

It is noted that the current ASHRAE adaptive model is based on data from non-residential buildings and its application in residential buildings requires further testing; nonetheless, a recent project uses this model to analyse the data from 60 houses in Sydney, Adelaide and Brisbane (Saman et al, 2013). The authors found that acceptable indoor temperatures in the study houses in summer fit within the acceptable limits as predicted by the adaptive model. Peeters et al (2009) also argues that an adaptive model of thermal comfort is likely the most appropriate approach for residential buildings. However, it is hypothesised in this research that current comfort ranges, either in *AccuRate* or based on the current adaptive model, do not necessarily

account for the thermal preferences of occupants in *low energy* dwellings. Few known thermal comfort studies have been conducted in residential buildings in Australia, let alone in *low energy* dwellings, resulting in the potential for inappropriate application of thermal comfort standards.

2. Methods

Forty households were recruited in late 2012, early 2013. The households were required to either be living in a dwelling incorporating earth construction walls (mud brick, rammed earth) in a cold temperate climate or operating their home as partially or wholly naturally ventilated in a hot humid climate. It was expected that the thermal conditions and thermal preferences of the occupants within these buildings would represent two extremes when compared to 'typical' conditions (e.g. those described by the ASHRAE adaptive model). All households were 'self-selecting'; responding to advertisements in a local paper or through material (websites, newsletters) circulated by interest groups (*Earth Building Association Australia*, *Nillumbik Mudbrick Association* and *CoolMob*). For statistical consistency the earth building households selected were all located in Nillumbik Shire, Victoria, Australia; while the naturally ventilated households were all located within Darwin, Northern Territory, Australia.

2.1. Meteorological and indoor environment data and equipment

The Nillumbik Shire is located north-east of Melbourne, Victoria and has the Köppen climate classification 'Csb'; Mediterranean climate, dry warm summer, mild winter. The climate has four distinct seasons. Average annual rainfall recorded at the closest Bureau of Meteorology (BOM) weather station, Viewbank (Station number 086068, latitude 37.74 °S, longitude 145.10 °E), is 680.3mm. The rainfall is fairly evenly distributed throughout the year with the wettest months being November and December and the driest January and March. Mean daily maximum temperatures range from 13.9 °C in July (winter) to 27.7 °C in January (summer), while mean daily minimum temperatures range from 5.8 °C in July to 14.6 °C in February. Humidity remains moderate throughout the year ranging from a mean 9am relative humidity of 86% in winter to a mean 3pm relative humidity of 43% in summer (BOM, 2013).

Darwin is located in the Northern Territory and has the Köppen climate classification 'BSh'; hot sub-tropical steppe. The climate has three main seasons; the build-up, the wet (monsoon) and the dry. Average annual rainfall recorded at the closest BOM weather station, Darwin Airport (Station number 014015, 12.42 °S, longitude 130.89 °E), is 1726.5mm. The majority of rainfall is received in the monsoon period through January, February and March. The driest period is through June, July and August where very low amounts of rainfall are recorded (1.9mm, 1.2mm and 5.0mm respectively). Mean daily maximum temperatures have a narrow range from 30.5 °C in July (the dry) to 33.3 °C in November (the build-up/the wet), while mean daily minimum temperatures have a similarly narrow range from 19.3 °C in July to 25.3 °C in November and December. Humidity is highest in the wet season with a mean 9am relative humidity of 83% (February) and lowest in the dry season with a mean 3pm relative humidity of 37% (July) (BOM, 2013).

For this research weather data (precipitation, air temperature, dew point, relative humidity, wind speed, direction and gust, and barometric pressure) were sourced from the closest BOM weather stations to the respective case study areas (Viewbank and Darwin Airport) for the monitoring period.

In general, data collection meets the requirements of a Class-II field study and the requirements of ASHRAE 55-2013 (ASHRAE, 2013) for data collection. Two HOBO U12-013 Data Loggers were installed in each house to measure and record air temperature, globe temperature and relative humidity. In addition, an anemometer sensor was included in the Darwin equipment to monitor indoor air movement. One logger was located in the household's primary living area and a second logger was placed either in a subsequent living area or the main bedroom. The loggers were located away from heat sources, out of direct sunlight and, where possible, in a central location within the room at approximately 1.1-1.7m above floor level.

2.2. Comfort vote survey

A paper based comfort vote survey in booklet form was distributed to all households, Figure 1; residents above the age of 18 years old were invited to fill them out on a daily basis. Three widely used subjective measures of thermal comfort were included; sensation 1=Cold to 7=Hot (ASHRAE, 2013); preference 1=Cooler, 2=No change, 3=Warmer (McIntyre, 1982) and; comfort 1=Very uncomfortable to 6=Very comfortable (Brager et al, 1993). The survey also asked the respondents to report their clothing level, activity, and window, fan and artificial heating/cooling operation. A final question asked respondents to identify any source of discomfort not directly related to temperature (i.e. draft, stuffy, dry, humid sensation). The respondents were instructed to complete the survey within the rooms that the loggers were situated. The surveys were collected after six months and manually entered into *Excel* spreadsheets with the time of filling out the survey form matching the corresponding time in the monitored data.

Occupant Identification: A B C D

1. How do you feel?
 Cold Cool Slightly cool Neutral Slightly warm Warm Hot

2. How would you like to feel?
 Cooler No Change Warmer

3. Are you ...
 Very Un-comfortable Un-comfortable Slightly Un-comfortable Slightly Comfortable Comfortable Very Comfortable

4. What best describes the level of clothing you are currently wearing?

5. What best describes the activity you have been doing in the last 15 minutes?

6. Do you have any windows or doors open for ventilation?
 Yes No

7. Do you have a portable or fixed fans operating?
 Yes No

8. Do you have artificial cooling appliances operating?
 Yes No

9. If you reported to be uncomfortable, how would you best describe the source of this discomfort?
 Too Drafty Too Stuffy Too Dry Too Humid

Other please explain _____

Date: / / Time: : am/pm Room:

Figure 1 Comfort vote survey

2.3. Environmental Attitude Inventory (EAI) survey

An EAI tool developed by Milfont & Duckitt (2007; 2010) was used to gauge the occupants' level of environmental concern based on 12 attitudinal scales, Table 1. The EAI asks respondents to indicate their extent of agreement or disagreement with 24

statements on a 7-point Likert scale. The scores given define two higher-order factors of environmental attitude; ‘preservation’ and ‘utilisation’ (Milfont & Duckitt, 2007). Seven of the 12 scales contribute to an overall preservation score, while five contribute to an utilisation score. The preservation dimension broadly reflects biocentric (ecocentric) concern (conservation and protection), while the utilisation dimension reflects anthropocentric concern (utilisation of natural resources) (Milfont & Duckitt, 2010).

Surveys were manually coded and entered into an *Excel* spreadsheet. Mean preservation and utilisation scores were calculated for each case study cohort. Two control samples (for the corresponding locations; north-eastern suburbs of Melbourne and Darwin) were sourced using a panel provider; *Online Research Unit*. The survey was administered online and, except for subsequent demographic questions, was identical to that conducted with the case study households.

Table 1 Twelve attitudinal scales for use in EAI survey (Milfont & Duckitt, 2007)

Scale label	Preservation	Utilisation
01 Enjoyment of nature	*	
02 Support for interventionist conservation policy	*	
03 Environmental movement activism	*	
04 Conservation motivated by anthropocentric concern		*
05 Confidence in science and technology		*
06 Environmental threat	*	
07 Altering nature		*
08 Personal conservation behaviour	*	
09 Human dominance over nature		*
10 Human utilisation of nature		*
11 Ecocentric concern	*	
12 Support for population growth	*	

3. Results

3.1. Indoor thermal conditions

Internal prevailing conditions when votes were recorded during the monitoring period are presented in Figure 2 and Figure 3 for the Melbourne and Darwin households. Accepted comfort zones for the relevant periods are also shown (ASHRAE, 2013, Appendix B). In the Melbourne dwellings, conditions were largely cooler than the comfort zone, while in Darwin, the conditions were largely warmer. The average air speed measured at the time of voting in the Darwin households was 0.21m/s.

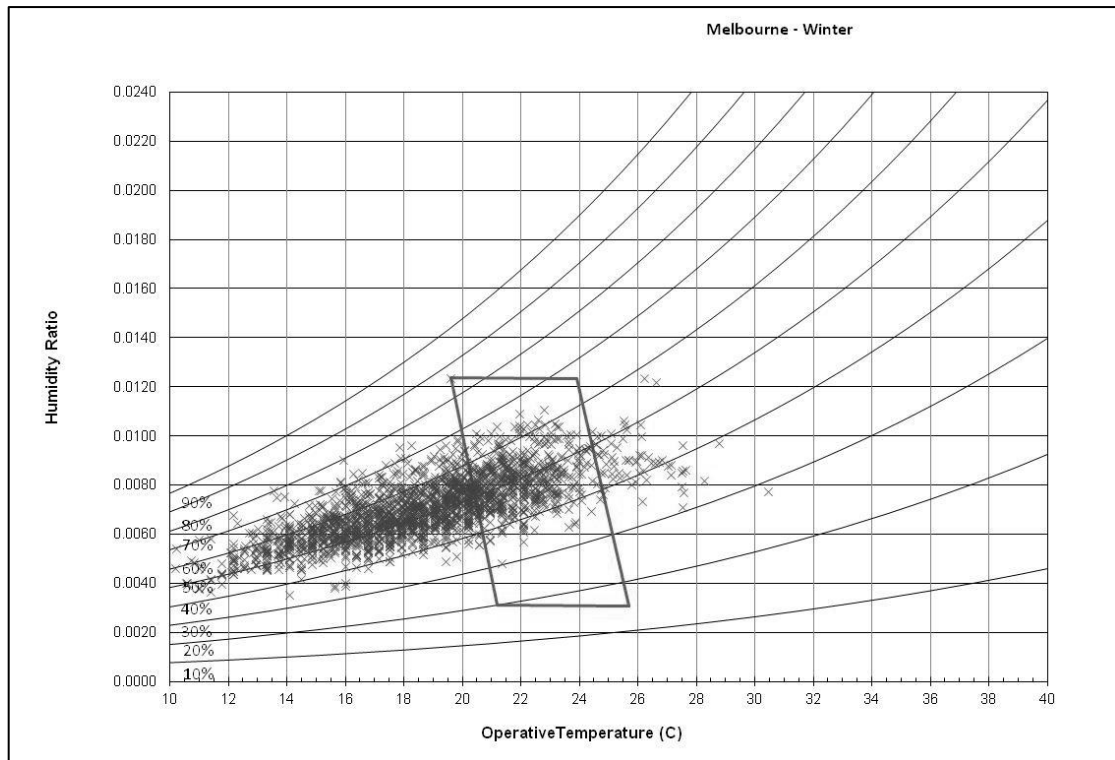

Figure 2 Comparison of the accepted winter comfort zone and the indoor operative temperature and humidity at the times comfort votes were recorded for Melbourne on the psychrometric chart

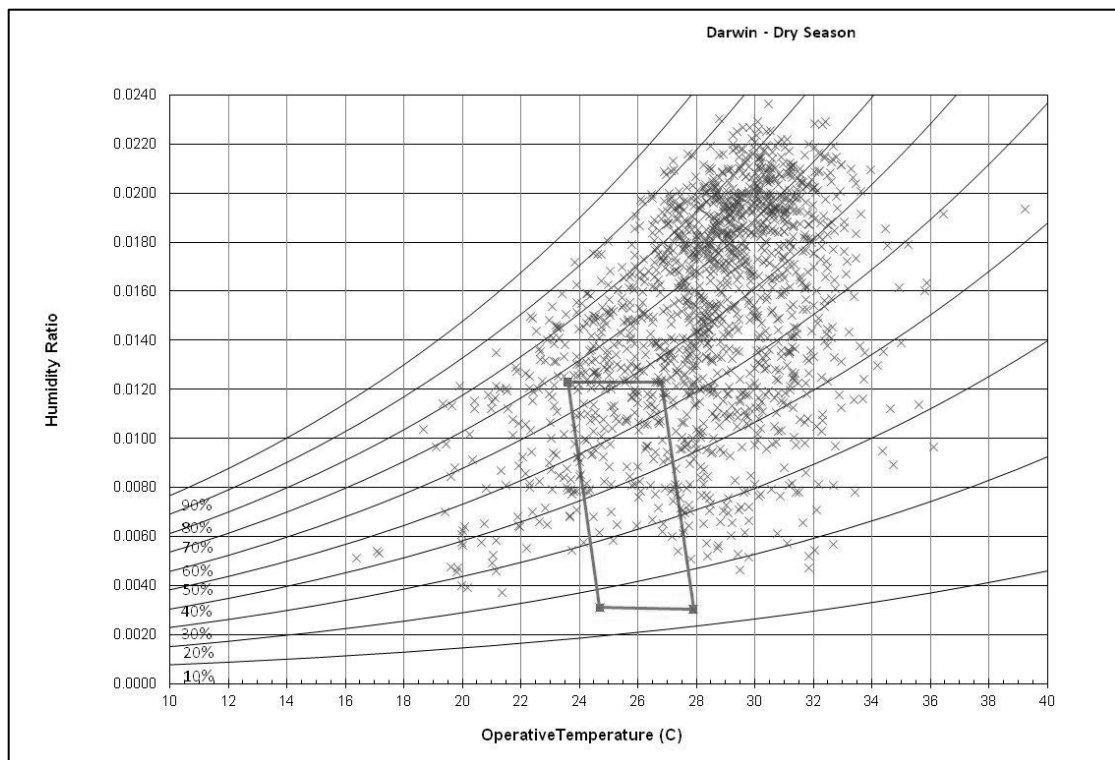

Figure 3 Comparison of the accepted dry season comfort zone and the indoor operative temperature and humidity at the times comfort votes were recorded for Darwin on the psychrometric chart

3.2. Thermal comfort survey

Two-thousand thermal comfort survey responses were collected from the Melbourne households between March and August 2013, representing the autumn and winter season; while fifteen-hundred responses were collected from the Darwin households between June and December 2013, representing the dry season and monsoon build up.

Cross-tabulation of the sensation and preference votes of the Melbourne cohort show that the most common vote was 'neutral' with a preference for 'no change (32.8%), Figure 5. Interestingly the subsequent highest percentages of votes recorded by the Melbourne cohort were for 'slightly warm' (14.8%), 'warm' (14.5%) and 'no change' indicating a preference for warmer sensation. A proportionally high percentage of votes at 'slightly cool' and 'warmer' (13.8%) similarly support the preference for 'neutral' or warmer sensation.

The cross-tabulation of the sensation and preference votes from Darwin reveal that 'neutral' and 'no change' was the most regularly recorded vote (41.8%), with high percentages also recorded at 'slight cool' (11.9%) and 'slightly warm' (18.4%) and 'no change'. Noticeable is the percentage of votes recorded at 'slightly warm' with a preference to be 'cooler' (7.8%) when observed in conjunction with the percentage of votes recorded at 'slightly warm' and 'no change'; the distribution of votes signifying the limit of preferred conditions.

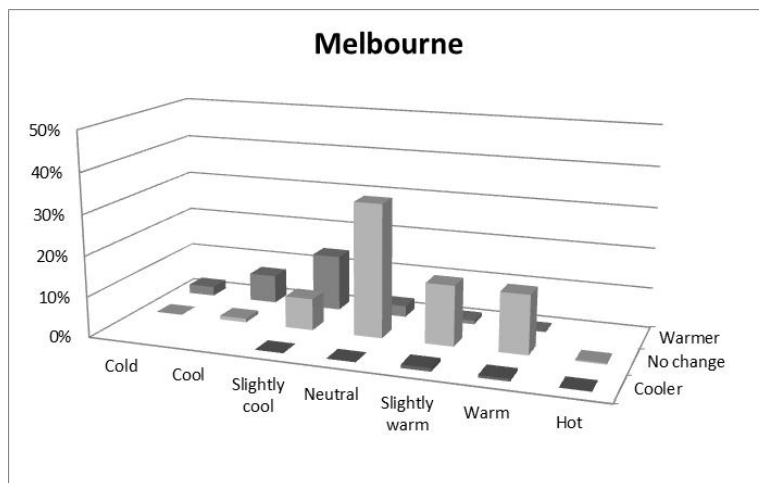

Figure 4 Sensation vs preference votes for the Melbourne cohort for the period of March - August 2013

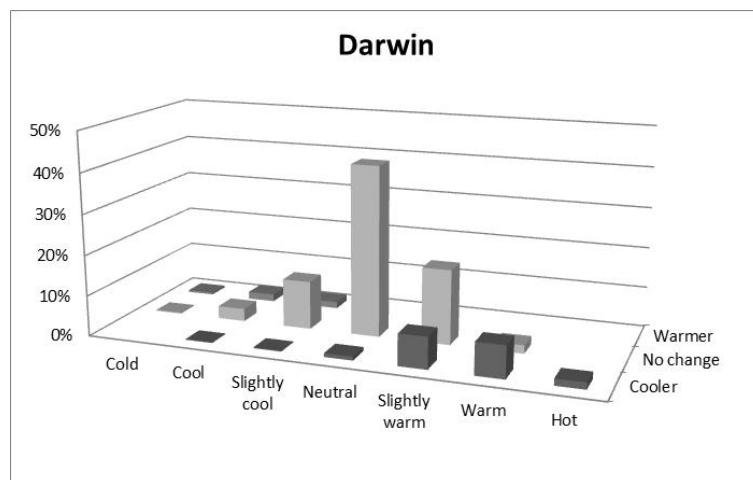

Figure 5 Sensation vs preference votes for the Darwin cohort for the period of June - December 2013

The cross-tabulation of the sensation and comfort votes, Figure 6, from the Melbourne cohort indicate that the highest percentages of 'comfortable' votes are recorded at 'neutral' (26.9%), 'slightly warm' (12.6%) and 'warm' (10.3%), again supporting the occupants' preference for warmer than neutral sensation; similarly echoed by the percentage of 'slightly cool' (9.1%) votes eliciting a 'slightly uncomfortable' response.

The sensation and comfort votes recorded by the Darwin cohort were predominantly at 'slightly cool' (7.6%), 'neutral' (30.2%), 'slightly warm' (11.5%) and 'comfortable', Figure 7. The votes show that the occupants rarely report to being uncomfortable when 'slightly cool' (1.0%), 'cool' (1.14%) and 'cold' (0.47%), rather, discomfort is recorded at 'slightly warm' (7.1%), 'warm' (6.89%) and 'hot' (1.54%), likely also due to relative humidity levels.

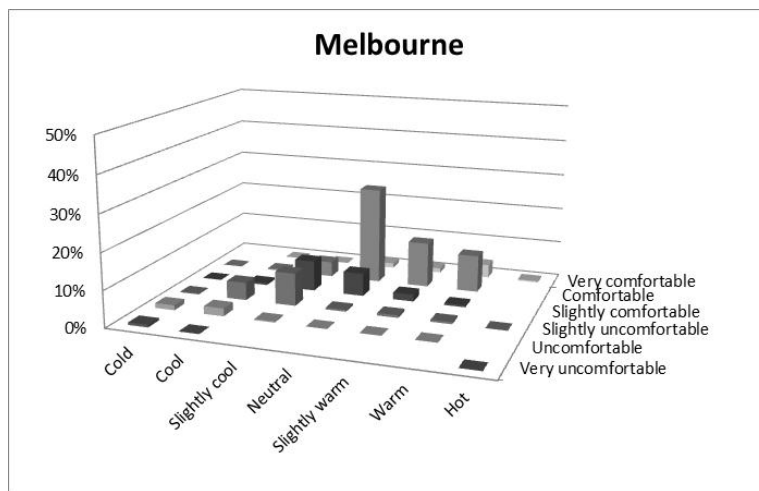

Figure 6 Sensation vs comfort votes for the Melbourne cohort for the period of March - August 2013

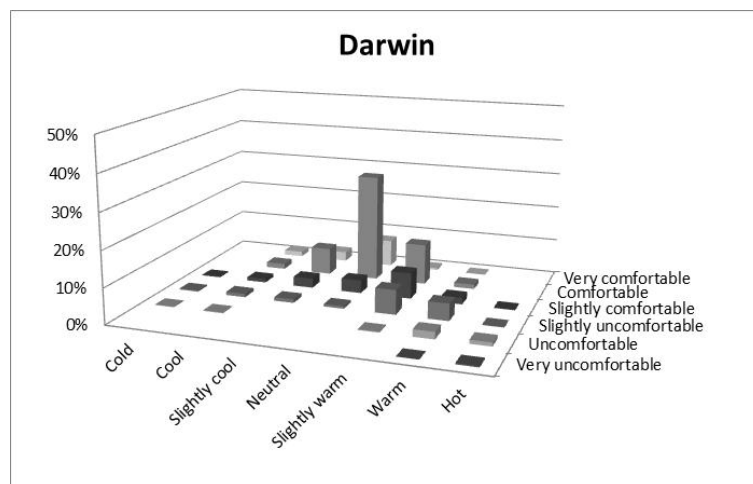

Figure 7 Sensation vs comfort votes for the Darwin cohort for the period of June - December 2013

Cross-tabulation of the Melbourne comfort and preference votes show that approximately half on the votes recorded were for 'no change' and 'comfortable' (52.0%). Notably, however, the second largest proportion of votes was reported when preference was to be 'warmer' at 'slightly uncomfortable' (13.2%), suggesting that cooler conditions were the primary source of discomfort.

The Darwin comfort and preference cross-tabulation indicates that generally occupants voted ‘no change’ at ‘slightly comfortable (12.8%), comfortable (49.2%) and very comfortable (12.3%), however it is interesting to note that some of the votes at slightly uncomfortable (3.1%) still had no preference to change. The highest percentage of votes recorded at slightly uncomfortable (10.0%) had a preference to be cooler, again indicating that warmth was the source of discomfort.

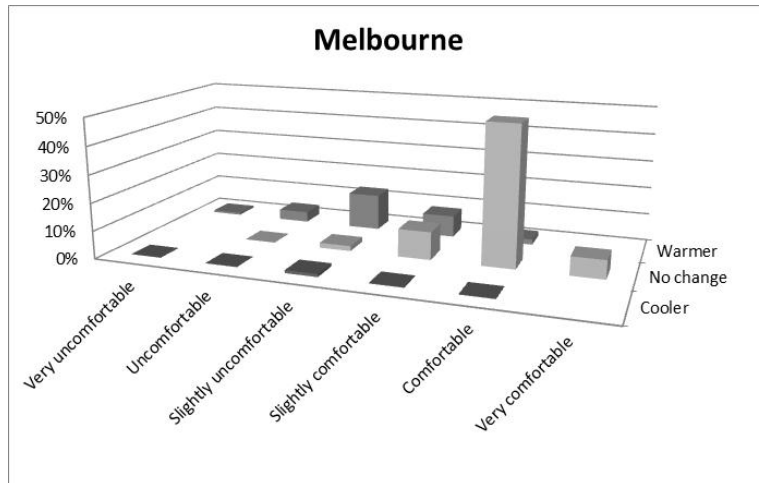

Figure 8 Comfort vs preference votes for the Melbourne cohort for the period of March - August 2013

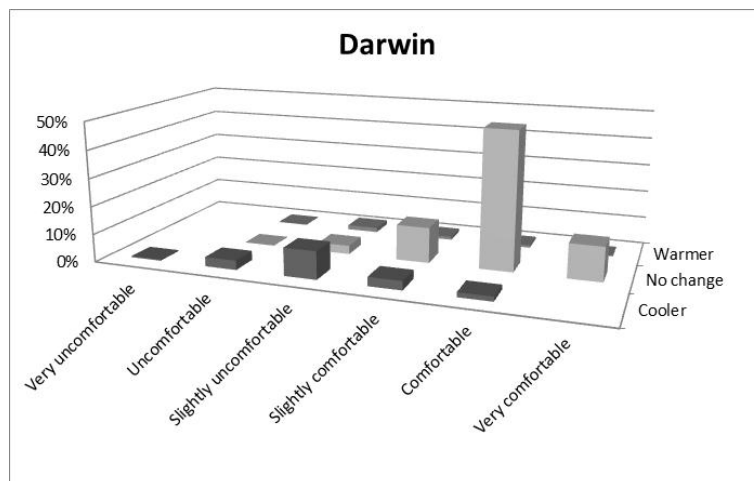

Figure 9 Comfort vs preference votes for the Darwin cohort for the period of June - December 2013

3.3. Comparison with the ASHRAE adaptive model

In order to compare the thermal comfort votes of the case study households to that of a *typical* population, instances where the respondents voted 'slightly cool', 'neutral', 'slightly warm' and 'no change' (SENS345/PREF2) were plotted against the ASHRAE 55 (2013) adaptive 80% and 90% upper and lower comfort limits, see Figure 10. These votes are taken to represent comfort temperatures of the two cohorts.

In general, the Melbourne cohort reported to be comfortable at lower temperatures than the ASHRAE adaptive model predicts as acceptable, while the Darwin cohort report to be comfortable at higher temperatures. The aggregate slope of the case study data trend line (0.63) is steeper than the trend line of the adaptive comfort model (0.31), demonstrating considerable difference between the thermal preference of the cohort studied and the adaptive neutral temperatures. This finding is comparable to

results presented in Williamson et al (1995), where the trend line slope of comfort data from Australian households was 0.58, suggesting that these finding may be more representative for residential buildings.

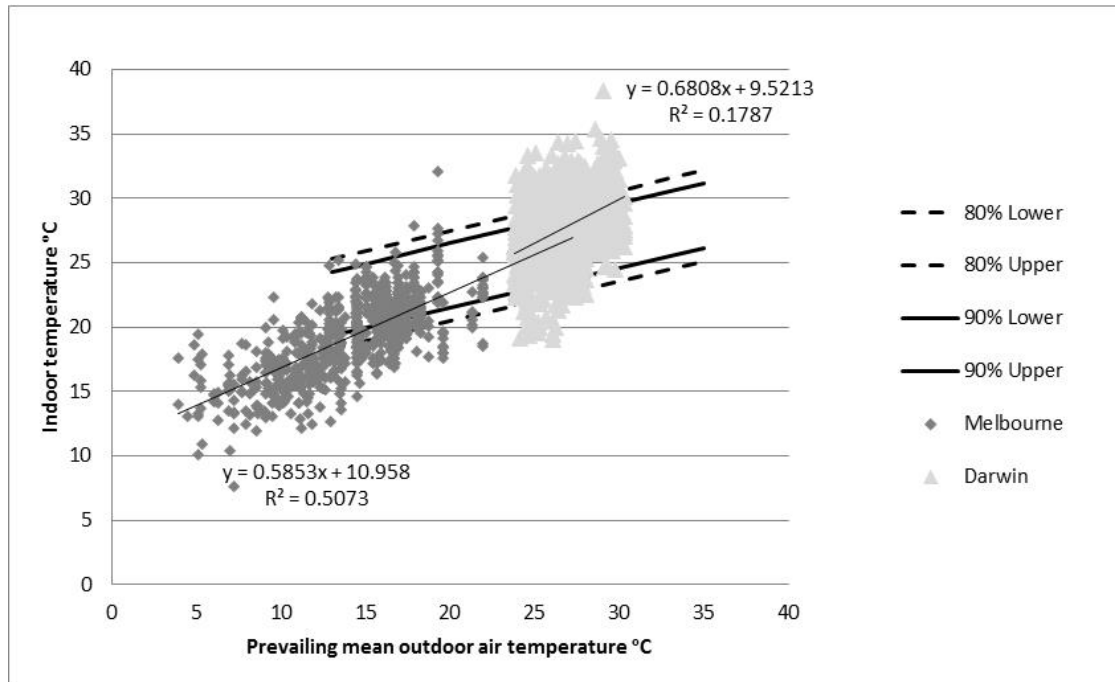

Figure 10 Votes when occupants report to be SENS345/PREF2, where prevailing mean outdoor air temperature is based on a 7-day running weighted mean of daily temperatures

The percentages of the SENS345/PREF2 votes that are outside of the ASHRAE upper and lower 80% and 90% limits are given in Table 2, the 80% and 90% adaptive limits are assumed to continue below 13 °C (Van der Linden et al, 2006). A substantial proportion of the SENS345/PREF2 votes are outside of the adaptive 80% and 90%; indicating a preference for a wider range of thermal conditions than the ASHRAE adaptive model describes as comfortable.

Table 2 Percentage of votes where occupants report to be 'slightly cool', 'neutral', 'slightly warm' and want 'no change' outside of the ASHRAE Adaptive 80% and 90% upper and lower limits

Cohort	Percentage outside 80% limits	Percentage outside 90% limits
Melbourne	41.18%	54.94%
Darwin	26.57%	46.96%

The cooler *comfort* temperature of the Melbourne cohort and the warmer *comfort* temperature of the Darwin cohort are apparent when the monthly $T_{SENS345/PREF2}$ for each location is calculated based on the corresponding regression equation shown in Figure 10, where x is the monthly mean outdoor air temperature, and plotted on a Nicol graph (Nicol & Humphreys, 2002) using the ASHRAE adaptive formula to obtain T_{conf} , equation (1), see Figure 11 and Figure 12.

$$T_{conf} = 0.31 \bar{T}_o + 17.8 \quad (1)$$

where \bar{T}_o is the monthly mean outdoor air temperature.

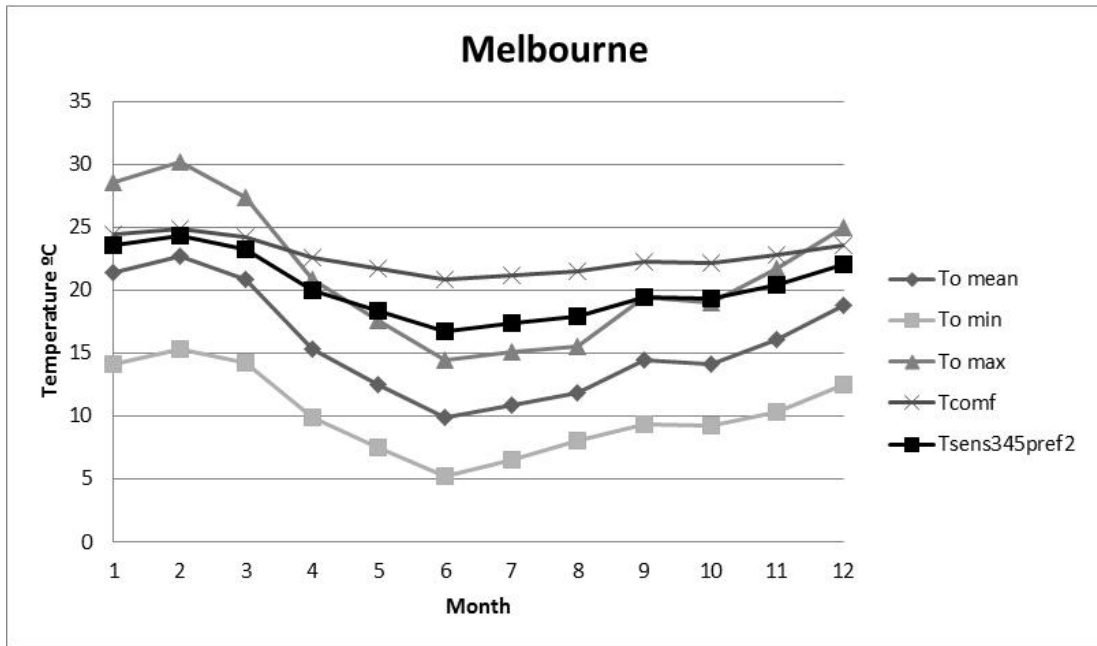

Figure 11 Comparing T_{comf} with $T_{comf,sens}$ for Melbourne using 2013 meteorological data

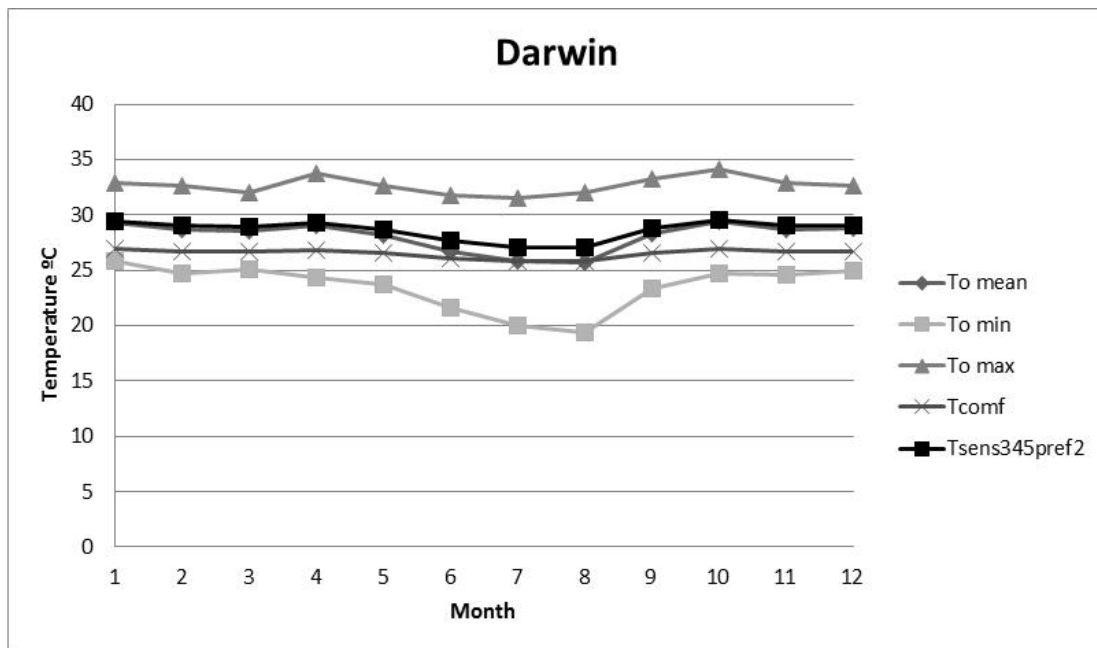

Figure 12 Comparing T_{comf} with $T_{comf,sens}$ for Darwin using 2013 meteorological data

3.4. Environmental Attitudes Inventory (EAI) survey

All adult occupants in the case study households were invited to complete the EAI survey; the Melbourne case study group returned 33 completed surveys, while the Darwin case study group returned 27, Table 3. At least one occupant completed the survey in each household. The commercial online panel provider obtained 113 control sample responses from the North-eastern suburbs of Melbourne and 36 from Darwin. The control samples correspond to population size.

Table 3 EAI mean preservation and utilisation scores for case study cohort and control groups

Cohort	Sample	Mean preservation score (standard deviation)	Mean utilisation score (standard deviation)
Melbourne case study cohort	33	5.55 (0.893)	2.99 (0.846)
Melbourne control	113	4.0 (0.460)	4.1 (0.471)
Darwin case study cohort	27	5.90 (0.633)	2.53 (0.749)
Darwin control	36	4.5 (0.900)	3.5 (0.850)

Paired-samples t-tests were conducted in order to compare the mean preservation and utilisation scores of the case study and control groups. The mean preservation scores for both the Melbourne and Darwin case study groups were higher than those of the control samples, indicating a greater level of biocentric concern relating to conservation and protection of the environment. On the other hand, the mean utilisation scores of the two case study groups were lower than the mean utilisation scores of the control sample, demonstrating a lower level of anthropocentric concern relating to the utilisation of natural resources. There was a significant difference in the mean preservation scores for the Melbourne case study sample (M=5.55, SD=0.893) and the Melbourne control sample (M=4.0, SD=0.460); $t(37.09)=9.6057$, $p<0.0001$. The utilisation scores for the Melbourne case study group (M=2.99, SD=0.846) when compared to the Melbourne control sample (M=4.1, SD=0.471) were also significantly different; $t(37.97)=-7.2176$, $p<0.0001$. Similarly, there was a significant difference in the mean preservation scores for the Darwin case study sample (M=5.9, SD=0.633) and the Darwin control sample (M=4.5, SD=0.900); $t(60.79)=7.2450$, $p<0.0001$. The utilisation scores for the Darwin case study group (M=2.53, SD=0.749) when compared to the Darwin control sample (M=3.5, SD=0.850) were again significantly different; $t(59.35)=-4.7994$, $p<0.0001$. These results suggest that both the Melbourne and Darwin case study groups have higher levels of environmental concern based on its intrinsic value rather than its anthropogenic utility when compared to the general population as represented by the control samples.

It is worth noting that the results presented in this paper align with those reported by O'Callaghan et al (2012); where the preservation (M=5.88, SD=0.59) and utilisation (M=2.65, SD=0.59) scores for the *Ecovillage* study group (n=39) were higher and lower, respectively, than the preservation (M=4.92, SD=0.62) and utilisation (M=3.35, SD=0.61) scores for the *Observatory* control group (n=36). So while this is not a commonly used tool in building science or thermal comfort research we can have some level of confidence in its consistency.

3.5. Household energy use

Whilst not a primary focus of this paper, the long-term energy use of the case study households was investigated in order to confirm that they can be considered as 'low energy dwellings' when compared to typical households in the same location. The average daily electricity consumption per household for the Melbourne cohort was

17.1 kWh, lower than the Nillumbik Shire average; 24.2 kWh (State Government of Victoria, 2013). Similarly, the average daily electricity consumption per household for the Darwin cohort was 14.6 kWh, again lower than the average for the Northern Territory; 24.4 kWh (Power and Water Corporation, 2011). This basic comparison corroborates the anecdotal evidence presented in the literature that these forms of dwellings can be considered as *low energy* forms of housing.

4. Discussion

During the course of analysis it became evident that development of upper and lower limits of comfort is particularly important for the practical application of any thermal comfort research. This prompted an investigation into the formation of the 80% and 90% upper and lower limits of the adaptive comfort model based on Fanger's (1970) PPD index (de Dear & Brager, 1998). Previous studies (Langevin et al, 2013; von Grabe & Winter, 2008) have sought to consolidate the relationship between preference and sensation votes in order to create a stronger model of discomfort.

In order to achieve this using data from the two case study cohorts, the comfort votes were binned by the running weighted daily mean temperature and filtered to exclude votes not at 3 =slightly cool, 4 =neutral or 5 =slightly warm on the ASHRAE sensation scale. Outliers were deleted based on the interquartile range test of the indoor temperatures and the data sets tested for normal distribution using the Shapiro-Wilk test. An *Excel* function was used to return the inverse of the normal cumulative distributions 0.1, 0.2, 0.8 and 0.9 based on the mean and standard deviation of the binned temperatures. Figure 13 and Figure 14 show the results for the Melbourne and Darwin data sets.

It is important to note that these boundaries do not represent the same thing as those presented in the ASHRAE adaptive comfort model; but rather, the upper and lower 80 and 90 percentiles of the two cohorts' votes that express satisfaction with the thermal environment. This has been taken to indicate a comfort range. This preliminary description of the thermal preference of the two case study cohorts clearly demonstrates the capacity of occupants to consider a wider range of thermal conditions comfortable with a tentative explanation attributed higher levels of pro-environmental attitudes.

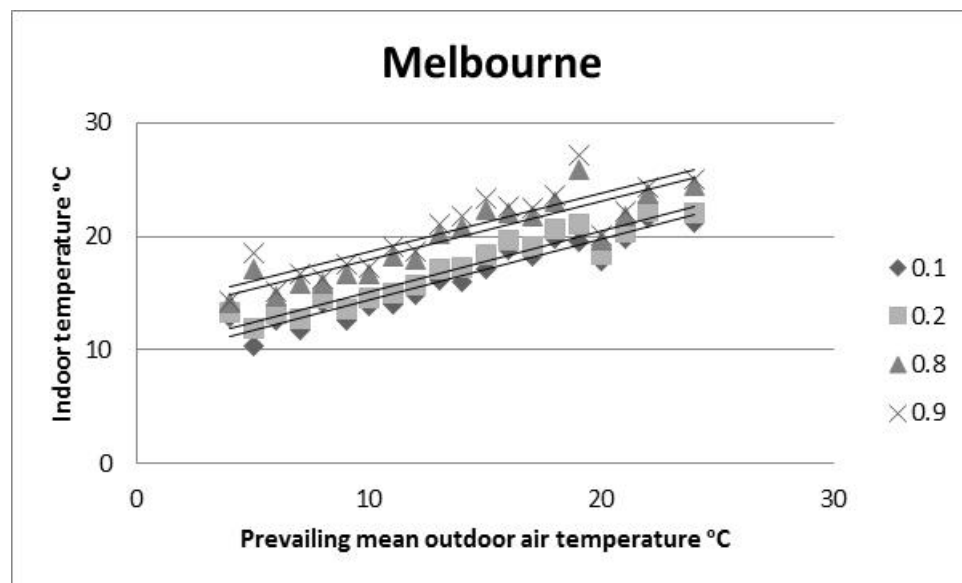

Figure 13 Upper and lower comfort limits based on collected data for Melbourne

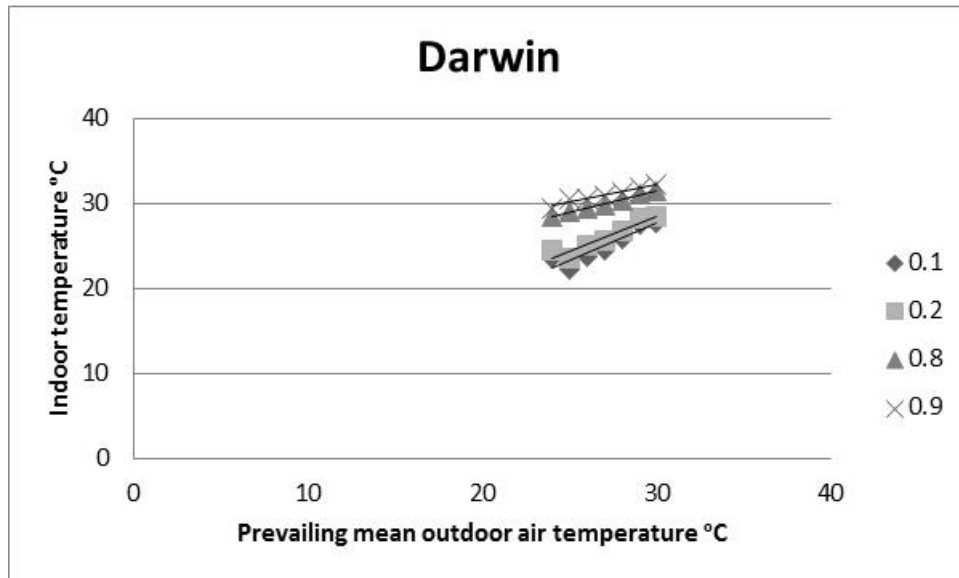

Figure 14 Upper and lower comfort limits based on collected data for Darwin

5. Conclusion

The analysis of preliminary data presented in this paper supports an association between atypical thermal preferences and higher levels of environmental concern in *low energy* houses and demonstrates the value of investigating ‘thermal maverick’ cases. Both of the cohorts studied, dwellings incorporating earth construction elements in a cold temperate climate and naturally ventilated houses in a hot humid climate, reported to be comfortable at temperatures outside of the ASHRAE adaptive comfort limits and demonstrated higher levels of environmental concern than the control samples. The data collected in this study contributes to a growing understanding of thermal comfort and preference in residential buildings. In addition, the results presented offer an extended way of thinking about adaptive thermal comfort, particularly in a time where boundaries in the provision of thermally comfortable spaces are being reassessed. While principally investigating a potential causal relationship between occupant thermal perception and preference in residential buildings, this basic relationship is also likely to be relevant for a wider range of buildings. It suggests that rather than simplification and standardisation, a wider diversity of comfort conditions should be considered.

Acknowledgements

We wish to thank the case study households for their cooperation. Funding was provided by the University of Adelaide through a DVC-R equipment grant and by CSIRO for the Darwin component of the study through a Studentship Agreement.

References

- ASHRAE., 2013. Thermal environmental conditions for human occupancy, *ASHRAE Standard 55-2013*, Atlanta, Georgia: American Society of Heating, Refrigerating and Air-Conditioning Engineers.
- Brager, G.; Fountain, M.; Benton, C.; Arens, E A.; & Bauman, F., 1993. A comparison of methods for assessing thermal sensation and acceptability in the field. In. *Thermal Comfort; Past, Present and Future*, Watford, July 1993, United Kingdom: British Research Establishment.

Casey, P., & Scott, K., 2006. Environmental concern and behaviour in an Australian sample within an ecocentric-anthropocentric framework, *Australian Journal of Psychology* 58(2), 57-67.

Candido, C., de Dear, R J., Lamberts, R., & Bittencourt, L., 2010. Cooling exposure in hot humid climates: are occupants 'addicted'?, *Architectural Science Review* 53(1), 59-64.

Chappells, H. & Shove, E., 2005. Debating the future of comfort: environmental sustainability, energy consumption and the indoor environment, *Building Research and Information* 33(1), 32-40.

Daniel, L., & Williamson, T., 2011. A study of the user behaviours in dwellings of earth construction. In: Hyde, R., Shahriar, A., Hayman, S., & Cabrera, D. (Eds.), *45th Annual Conference of the Australian and New Zealand Architectural Science Association: From principles to practice in architectural science*, (CD-ROM), 16th-18th November 2011, Sydney: Faculty of Architecture and Planning.

de Dear, R J., 2004. Thermal comfort in practice, *Indoor Air* 14(7), 32-39.

de Dear, R J., & Brager, G., 1998. Developing an adaptive model of thermal comfort and preference, *ASHRAE Transactions* 104(1), 145-167.

Dethier, J., 1981. *Down to Earth, Mud Architecture: an old idea, a new future*. Spain: Thames and Hudson.

Deuble, M P., & de Dear, R J., 2012. Green occupants for green buildings: The missing link?, *Building and Environment* 56, 21-27.

Easton, D., 1996. *The Rammed Earth House*. Vermont: Chelsea Green Publishing Company.

Fanger, P O., 1970. *Thermal comfort: Analysis and Applications in Environmental Engineering*, United States: McGraw-Hill Book Company.

Gill, Z. M., Tierney, M J., Pegg, I M., & Allen, M., (2010). Low-energy dwellings: the contribution of behaviours to actual performance, *Building Research and Information* 38(5), 491-508.

Healey, K., & Webster-Mannison, M., 2012. Exploring the influence of qualitative factors on the thermal comfort of office occupants, *Architectural Science Review* 55(3), 169-175.

Hitchings, R., 2009. Studying thermal comfort in context, *Building Research and Information* 37(1), 89-94.

Kordjamshidi, M., 2011. *House Rating Schemes: From Energy to Comfort Base*. New York: Springer.

Langevin, J., Wen, J., & Gurian, P L., 2013. Modeling thermal comfort holistically: Bayesian estimation of thermal sensation, acceptability, and preference distributions for office building occupants, *Building and Environment* 69, 206-226.

Mazar, N., & Zhong, C B., 2010. Do Green Products Makes Us Better People?, *Psychological Science* 21(4), 494-498.

McIntyre, D A., 1982. Chamber studies - Reductio ad Absurdum?, *Energy and Buildings* 5, 89-96.

Milfont, T L., & Duckitt, J., 2006. Preservation and Utilization: Understanding the Structure of Environmental Attitudes, *Medio Ambiente y Comportamiento Humano* 7(1), 29-50.

Milfont, T L., & Duckitt, J., 2010. The environmental attitudes inventory: A valid and reliable measure to assess the structure of environmental attitudes, *Journal of Environmental Psychology* 30, 80-94.

Nicol, F., Humphreys, M A., & Roaf, S., 2012. *Adaptive Thermal Comfort: Principles and Practice*. Oxon: Routledge.

Nicol, J F., & Humphreys, M A., 2002. Adaptive thermal comfort and sustainable thermal standards for buildings, *Energy and Buildings* 34, 563-572.

O'Callaghan, B., Green, H J., Hyde, R A., Wadley, D., & Upadhyay, A., 2012. Exploring the influence of housing design and occupant environmental attitudes on energy and water usage, *Architectural Science Review* 55(3), 176-185.

Peeters, L., de Dear, R J., Hansen, J., & D'haeseleer., 2009. Thermal comfort in residential buildings: Comfort values and scales for building energy simulation, *Applied Energy* 86, 772-780.

Power and Water Corporation., 2011. *Going solar – Frequently asked questions*, accessed 8 December 2013, <http://www.powerwater.com.au/customers/save/photovoltaic_pv_solar_systems/going_solar_faqs>.

Rael, R., 2009. *Earth Architecture*. New York: Princeton Architectural Press.

Roaf, S., Nicol, F., Humphreys, M., Tuohy, P., & Boerstra., 2010. Twentieth century standards for thermal comfort: promoting high energy buildings, *Architectural Science Review* 53(1), 65-77.

Saman, W., Boland, J., Pullen, S., de Dear, R., Soebarto, V., Miller, W., Pocock, B., Belusko, M., Bruno, F., Whaley, D., Pockett, J., Bennetts, H., Ridley, B., Palmer, J., Zuo, J., Ma, T., Chileshe, N., Skinner, N., Chapman, J., Vujinovic, N., Walsh, M., Candido, C., & Deuble, M., 2013. *A framework for adaptation of Australian households to heat waves*, Gold Coast: National Climate Change Adaptation Research Facility, 242 pp.

State Government of Victoria., 2013. *Residential energy use*, accessed 8 December 2013, <<http://www.climatechange.vic.gov.au/greenhouse-gas-emissions/residential-energy-use#heading-73546>>.

van der Linden, A C., Boerstra, A C., Raue, A K., Kurvers, S R., & de Dear, R J., 2006. Adaptive temperature limits: A new guideline in The Netherlands. A new approach for the assessment of building performance with respect to thermal indoor climate, *Energy and Buildings* 38, 8-17.

von Grabe, J., & Winter, S., 2008. The correlation between PMV and dissatisfaction on the basis of the ASHRAE and the McIntyre scale - Towards an improved concept of dissatisfaction, *Indoor and Built Environment* 17, 103-121.

Williamson, T J., Coldicutt, S., & Riordan, P., 1995. Comfort, preferences or design data?, In. *Standards for Thermal Comfort: Indoor Temperature Standards for the 21st Century*. Nicol, F., Humphreys, M., Sykes, O., & Roaf, S. (Eds), London: E & FN Spon, 50-58.

Proceedings of 8th Windsor Conference: *Counting the Cost of Comfort in a changing world*
Cumberland Lodge, Windsor, UK, 10-13 April. London: Network for Comfort and
Energy use in Buildings, <http://nceub.org.uk>

The Effect of Climate and Culture on Housing among Low Income Groups in Lagos, Nigeria

Akinwolemiwa feyikemi and Gwilliam Julie

Welsh School of Architecture, Cardiff University

Keywords: V.G.S Vertical Greening Systems, L.I.G: Low Income Groups, Housing, Climate change, Culture

Abstract

The Low Income Group (L.I.G) in Lagos, Nigeria represents about 70% of the 18million population of the state. They are an important part of the economic activities in the state, with the bulk of public transportation and informal trading being undertaken by these groups.

Housing, as the second most important human need after food has a profound influence on the health, efficiency, social behaviour, satisfaction and general welfare of the community. Thus, the provision of comfortable housing for the L.I.G has the potential to result in a significant benefit to the whole society as well as having a direct impact on the L.I.G. psyche.

This paper seeks to present a review of the current housing conditions of the L.I.G based on previous studies of the largest slum areas within the city. In particular the implication of having extended family members cohoused, a fundamental cultural phenomenon that typically leads to widespread overcrowding, is discussed. Further, a study of the potential effect of global warming on comfort conditions within the houses is discussed, also drawing from past studies.

Finally, the potential that Vertical Greening Systems might have in helping to upgrade present living conditions, especially in improving thermal comfort are analysed.

Considering the concept of sustainability, the built environment is responsible for almost 40% of the global emissions. What can be defined as sustainable or eco-architecture represents an attempt to respond to global environmental problems and to reduce environmental impacts due to building and housing industry which includes the exclusion of natural resources, the emission of CO2 and other greenhouse gases', (Perini, 2011).

INTRODUCTION

Low income groups in Lagos, Nigeria (See Plate 2) represent about 70% of the total population in the city (Akinmoladun, 2004). UNDP (2008) estimates that 51% of men and 54% of women resident in Lagos survive on less than US\$1 a day, with their average income being approximately N15, 000 a month (£55) (Aluko, 2004). These groups, also referred to as the 'urban poor', are further described by Olotuah, 2005 '*These are the urban poor who are subjected to a life characterized by precarious conditions of lack of nutrition and health, little or no material possessions, substandard housing and a generally degraded environment. Their housing does not ensure dry shelter, safe water supply, drainage, sewerage and refuse disposal, as well as access roads. The houses constitute a health risk to its occupants*'.



Plate 1: Typical low income residence in Lagos, Nigeria: Accessed May, 2013: Source: Lawanson et al

LOCATION OF LOW INCOME GROUPS IN LAGOS



Plate 2: Nigeria, West Africa: Source; Google image: Accessed; Nov; 2012.

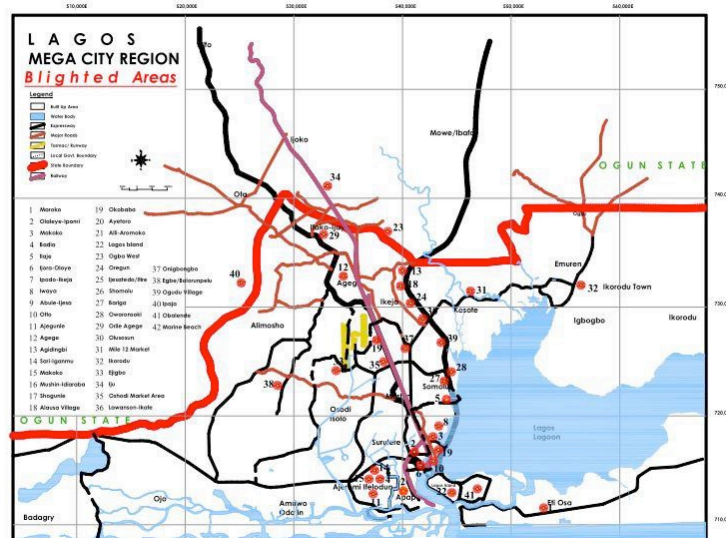

Plate 3: Location of Low income groups in Lagos Nigeria, Source: Lagos State Official Website; Accessed Feb 2013.

The typical occupation and economic importance of LIG in Lagos will now be discussed in order to place this paper in an appropriate context.



Plate 4: Home based enterprise in low income houses, Lagos, Nigeria, Source: Lawanson et al, 2012: Accessed Jan 2013

The Low income groups also known as the ‘Urban Poor’ largely secure their income through “informal sector employment”, especially in Home Based Enterprises, also known as Household enterprises or unincorporated enterprises. These enterprises are owned by households and can be distinguished from corporations and quasi-corporations on the basis of their legal status and the type of accounts they hold. They are usually run from their homes or within the vicinity, reducing associated costs such as transportation, rents (Lawanson, et al, 2012). Lagos State Government (2004) estimates that 50% - 75% of the population are employed within the informal sector. Only about 20% of them are employed in the formal sector, frequently this is due to lack of educational qualifications

(HBEs) are important in times when formal wages diminish or cease and enterprises are started in the only place available (the home). According to Lawanson et al (2013). The advantages of HBEs for the low income groups include;

The ability to maintain an enterprise at little overhead cost

- 1. To make use of household resources, especially space and utility connections. Indeed, the home provides the ultimate environment for trading off resources between domestic and productive activities;*
- 2. To make effective use of time and money particularly by avoiding travel to work;*
- 3. To make effective use of social and human resources, particularly relatives and friends in the enterprises in exchange for small sums of money or benefits in kind; and to enable women to have productive work even in societies where their movement and social interaction are restricted”.*

The interest in financial savings is increased among these groups due to the limited finances generated with these economic activities.

Informal sector employment is a necessity survival strategy especially in many countries that lack social safety nets such as unemployment insurance and effective pension schemes (Yasmeen, 2001). Commercial activities are very strong in the city and are carried out at both formal and informal levels (Abiodun, 1993). Typical informal sector employment is found in Lagos for the LIG with examples illustrated in Plate 5 & 6 below. Such work is irregular, in micro-enterprises and is typically low paid. Through such enterprises, the Lagos

LIG, organize savings and loans group so as to gather investments in housing and business and produce and sell goods and services to each other and the bulk of the population within the city. It can be seen therefore that the LIG supports the city as a whole, through activities including: hawking, selling of cooked food, raw farm produce and other minor household items.



Plate 5: informal sector employment i.e. hawking Source: Lawanson et al, 2012: Accessed May 2013



Plate 6; informal sector employment i.e. fish mongers Source: Lawanson et al, 2012: Accessed May 2013

In the study carried out by Lawanson and Olanrewaju in 2012, among 31 selected neighbourhoods with 394 respondents in 16 local government areas that make up the Lagos Metropolis, The survey intended to critically examine the phenomenon of Home based enterprise in selected low income enterprise The results revealed a number of trends common with most low income neighbourhoods . Data was obtained by the administration of structured questionnaires and analysis was done by both parametric and non-parametric methods.

Random sampling of 394 home based enterprises was carried out; the results have been broken down into subtopics to give an overall view of these neighbourhoods. The study took a total of 3 months, and it cut across a number of Low income group areas. Thus, a wide range of responses was gotten, and an opportunity for comparison was available.

Variable		N=394	%
Gender	Male	213	53.78
	Female	183	46.22
Age	≥15	8	2.02
	16-30	165	41.66
	31-45	162	40.91
	46-60	50	12.63
	≤ 61	11	2.78
Highest level of education attained	No Formal Education	30	7.58
	Primary Education	77	19.44
	Secondary Education	162	40.91
	Tertiary Education	127	32.07
Household size	1-3	94	23.74
	4-6	225	56.81
	7-9	63	15.91
	≤ 10	14	3.54
Housing Tenureship	Owner occupied	59	14.87
	Inherited/ family owned	47	11.84
	Tenant	275	69.30
	Squatter	15	3.78
No of rooms for exclusive household use	1	81	20.41
	2	142	35.78
	3	123	30.99
	<4	50	12.60
No of households in the buildings	1	24	3.05
	2-4	96	24.19
	5-8	202	60.90

Figure 1: Summary of result of the study of Low income groups in Lagos by Lawanson et al, 2012, accessed January 2014

Households of approximately 7-9 made up about 15.91% of respondents. The highest number of occupants was 4-6 people. Larger households of more than 10 people comprised of 3.78% of all the respondents and were particularly evident in neighbourhoods like Ajegunle (the largest slum area in Lagos) and Mushin. This result is evident in most low income households within the state, overcrowding in houses are very common.

Variable		N=394	%
Monthly income from home enterprise	≤ N7,500	97	24.64
	N7,500 - N15,000	115	29.21
	N15,000 - N30,000	94	23.59
	N30,000 – N60,000	61	15.49
	≥ N60,000	27	6.86
Monthly income from other sources	None	201	51.05
	≤ N7,500	51	12.95
	N7,500 - N15,000	60	15.24
	N15,000 - N30,000	51	12.95
	N30,000 – N60,000	21	5.334
Other Income Source	≥ N60,000	10	2.54
	Office Job	82	20.83
	Inheritance	38	9.65
	Rent	17	4.32
	Income from Abroad	65	16.51
Other family income earner	Cooperatives/ Thrift	98	24.89
	Spouse	272	69.08
	Children	69	17.53
Possession of assets	Relatives	53	13.46
	Land	213	53.79
	House	210	53.03
	Car	119	30.05
Possession of household items	motorcycle	41	10.35
	Generator	257	64.89
	Air conditioner	14	3.53
	Electric Cooker	123	31.06
	Deep Freezer	182	45.96
	DVD Player	335	84.60

Figure 2: Summary of result of the financial study of Low income groups in Lagos by Lawanson et al, 2012, accessed January 2014

From the table above, the major variables tested here are possession of basic assets i.e. car, motorcycle, ownership of land or house. Data was also gathered on the number of additional income earners in the family as well as number of streams of income. Incomes from home enterprise and other sources are also gathered. It is revealed that about 49% of the respondents rely solely on their home enterprises. The modal monthly income from home enterprises is N7, 500 – N15, 000 (£29-£48). This accounts for about 29.21% of respondents. With 53.85% of respondents earn less than N15, 000 (£48) monthly from their home enterprise, while 24.64% earn below the national minimum wage of N7, 500 (£29), this category of people automatically fall under the ‘absolute poor’ category. In Lagos, the average earning for a single adult is 48 pounds per month (N15, 000). (Lawanson et al.2012).

It can be seen that the principal needs for the LIG in Lagos therefore survival, from day to day, The L.I.G are limited in their financial capabilities and , therefore any opportunity for improved environment must be designed to have low initial costs as well as a clear or even obvious pay back in both financial and environmental performance terms.

Current Climate Comfort and Culture:Effect on Low income Groups in Lagos, Nigeria)

Further challenges associated with the housing environment for LIG in Lagos is provided by the tropical climate, the housing morphology and cultural considerations. These will now be discussed in turn.

Climatic Considerations:

The climate is. Characterized by high ambient temperatures and solar radiation, a combination of these and other factors often cause thermal discomfort in buildings. (Ojebode and Gidado, 2012). Ojo et al (2000) also emphasized that Lagos State, which consists of large areas of lowlands is very vulnerable to the impacts of climate change and sea level rise. This is due to the State characterized by low lying areas, most of which are below 41m

In the context of climate change, defined by the IPCC (2007) as a change in the state of the climate that can be identified (e.g., by using statistical tests) by changes in the mean and /or the variability of its properties, and that persists for an extended period typically decades or longer, such challenges as are presented by the climate are set to increase. Studies have shown that climate change will be global, likewise its impacts, but the biting effects will be felt more by the developing countries, especially those in Africa, due to their low level of coping capabilities (Nwafor 2007; Jagtap 2007 cited in Odjugo, 2010). Nigeria is one of such developing countries.

For Lagos the climate challenges are further exacerbated by the existing, and likely worsening urban heat island effect. UHI phenomenon can cause air temperature in the cities to be 2-5C higher than those in the surrounding rural areas mainly caused by the amount of artificial surfaces (high albedo) compared with natural land cover (Taha, 1997 cited in Perini, 2011). Lagos lies on the gulf of Guinea, along the Bight of Benin Lagos state has a land area of about 356,861 Hectares (3568.6km²) representing only 0.4% of Nigeria's land area, (Lagos State Government Official Website) 17% of the total land area consists of lagoons, creeks and waterways (Balogun, Odumosi and Ojo 1999), cited in Ilesanmi (2010, p.10). Thus, the effect of UHI is enormously felt with overheating due to overpopulation on a small area of land.

Housing morphology among low income groups

Housing reflects the cultural, social and economic stance of any given society (Olukayode, 2003 et al cited in Gambo, 2012) the quote by Mandelker cited in Akinmoladun, 2004 explains housing as, *“being more than physical structures: housing has become a subject of highly charged emotional content: a matter of strong feeling. It is the symbol of status, of achievement, of social acceptance. It seems to control, in large measure the way in which the individual, the family perceives him/itself and is perceived by others”*. It encompasses the totality of the environment and infrastructure which provide human comfort, enhance people's health and productivity as well as enable them to sustain their psycho-social or psycho-pathological balance in the environment where they find themselves (Afolayan, 2007). Quality housing is one of the litmus test of a developed society. This is because a house goes beyond provision of mere shelter; it is a place where people recuperate, rest and bond with family.

Despite the acknowledged importance of housing to man, there are several housing problems throughout the world, and particularly in developing nations. These problems are both qualitative and quantitative in nature, manifesting in different shades of societal ills and decadence (Dogan, 2009 cited in Aduwo, 2011).

The most popular form of Urban Housing for the LIG in Lagos is the double banked Apartment block with rooms or flats on two sides opening to a common corridor leading to a stairwell. The corridor is generally narrow with poor lighting and ventilation. Cross ventilation is difficult to achieve within the flat because the door to the corridor is always

locked for reason of security and windows do not open, also for security reasons. (Olusanya, 2012). This is also called ‘Brazilian style housing’ or the more informal term called ‘face me I face you’. It is not unusual to find an average of 6 people in an 18m^2 space. This is partly due to profit maximization by the Landlords or accommodating friends and relatives, thus leading to overcrowding in these houses.

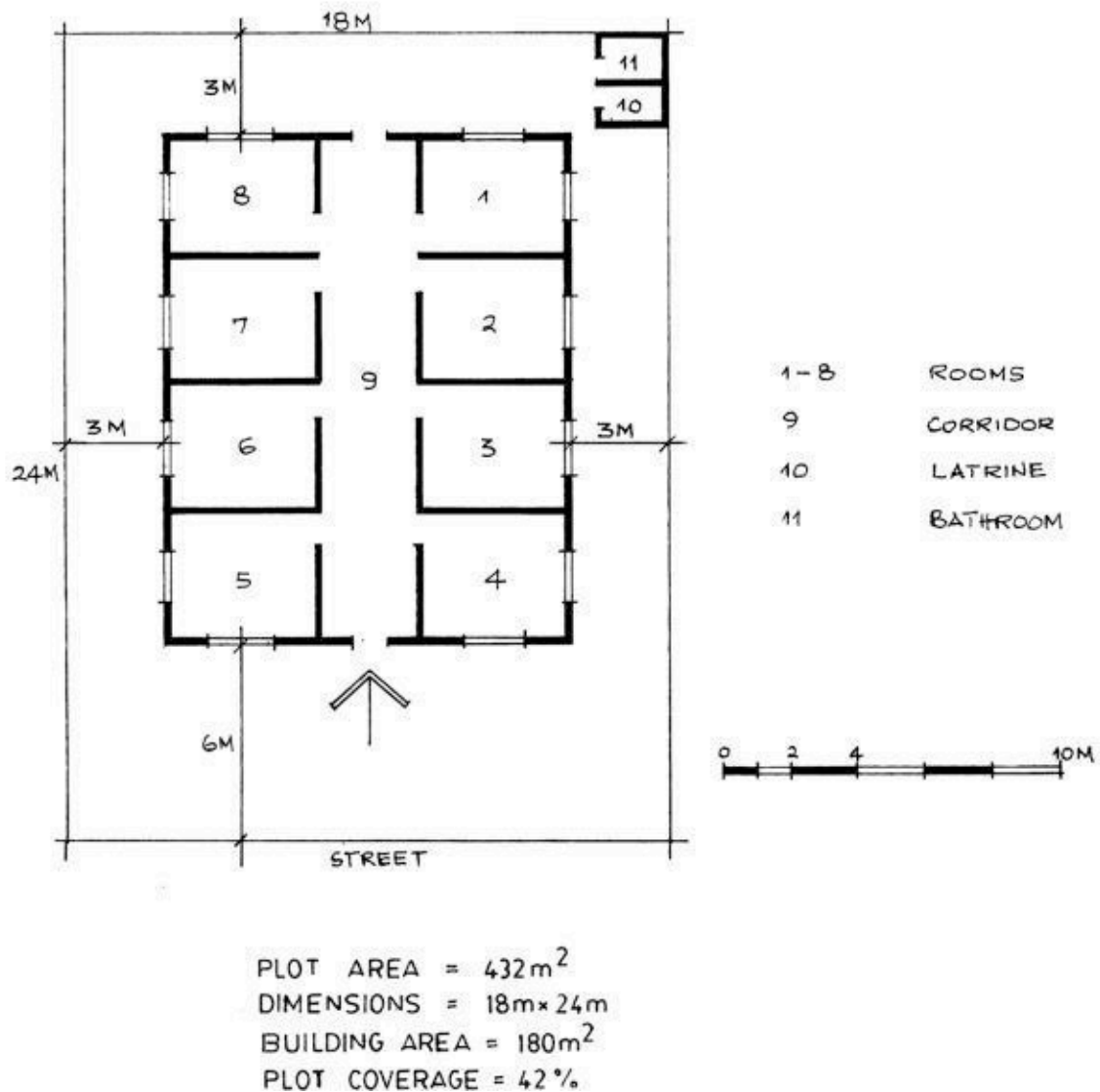

Figure 3: Morphology of low income housing in Lagos by olusanya, 2012, accessed January 2014

The floor plan above shows the typical Layout of Low income houses on a standard Plot of Land ($18\text{m} \times 24\text{m}$). The long narrow corridor is usually poorly lighted; the bathroom and Pit Latrine can be shared by almost 50 people in extreme cases. Absence of cross ventilation causes overheating and great discomfort, while, mechanical cooling devices are usually inefficient due to poor electricity supply .The corrugated roofing sheets are cheap to install, , but also contribute directly to overheating in the interior spaces, as heat gain is directly and efficiently conducted to the interior space. The buildings are usually built with concrete block work or wood for the extremely poor. The concrete block walls absorb heat during the day, leading to overheating in interior spaces through the latter part of the day and

through the night. With increase in temperature due to global warming, the existing discomfort in interior spaces will only worsen.

Thus, any means of achieving thermal comfort that are both environmentally friendly and financially saving will be of immense help to these groups. VGS has the potential to relieve the financial stress of attaining thermal comfort among these groups. This is due to non-demand for electricity by this system it is ideal to ensure that the dwellings they can afford are as comfortable as possible without stress on their meagre finance. By comfort, it means upgrading the slums to provide an environment where recuperation is efficient.

Cultural considerations

Cultural considerations in housing is a broad topic, however, two aspects of culture affect housing that are discussed in this paper are:

1. Communal living which often includes extended family members and friends. This is often due to the culture of a sense of community and belonging often associated with the average Nigerian.
2. Deliberate overcrowding by landlords to maximize profit for rents.

As analysed by Ahianba and Dimuna, 2008, the implications of overcrowding, coupled with the global warming effects are discussed below:

This arises from over population and insufficient accommodation. In Lagos, it is not unusual for a household to consist of external family members. This is due to the close family unit that characterizes a typical Nigerian. Thus, houses designed to accommodate 4 people may in actuality accommodate up to 10 people in certain cases leading to overcrowding. Overcrowding is a problem that has social and health effects.

Asbell observed in 1975 that '*Crowding is a specific happening, clinically observable and definable. In simplified terms crowding occurs when organisms are brought together in such a manner and numbers as to produce physical reactions of stress. Important among these reactions is steeped up activity of the adrenal glands. When these reactions too stress are wide spread and sustained, they are followed by physical weakening, sometimes rage and violence of extreme passivity, a rise in sexual aberrations and a breakdown of orderly group behaviour. What may follow is a tidal wave of deaths, ending when the population is no longer crowded*'. Overcrowding is a norm in low income housing.

Furthermore, the wider implications of overcrowding are numerous, ranging from non-compliance, with building laws to substandard housing conditions. Below are a summary of the implications of overcrowding on a low income residence.

1. Noncompliance with building Bye-Laws and Regulations

The Consequences of non-compliance with building bye-laws and regulations are already manifesting and are being felt in our urban centres.

The town planning requirements for 3m setback in between houses and 6-9m setback from roads have been grossly flaunted. The danger in violation of setback standards is that in the case of fire outbreak, it is difficult for fire vehicles and men to gain easy access to the building. This could result in deaths and loss of valued properties. Another related problem is the issue of density. The acceptable site coverage is 50% for residential buildings in high

density area and 33% for low density areas, but these are not complied with especially in high density areas where greedy developers built as much 70% of the site. The consequences are overcrowding and inadequate parking spaces (Ahianba and Dimuna, 2008)

Urban poverty finds expression in an environment characterized by high densities of buildings, the crowding of large numbers of people into those buildings, lack of space for open air living between houses, poor health, substandard housing, and acute environmental and sanitary problems (Olotuah, 2009). Asojo, 2010 stated that Squatting is a major problem in most African Urban Centres where the rate of migration far exceeds states resources for public housing construction.

2. Poor ventilation

Izomoh and Olomu in 2005 noted that most residential buildings have been planned, designed and constructed with little or no consideration for the following:

- Thermal comfort through the process of cross ventilation
- Reduction of the entry of rain and moisture into the buildings which results in breeding of various kinds of fungi that contaminates food items and cause breathing problems
- Outdoor living possibility within the compounds in the urban area.

As a result of poor ventilation in most buildings, people sleep outside with their mats for fresh air especially when the weather is extremely hot. The reason for this is because their houses are either not cross ventilated or are blocked by another house or fence due to improper planning of the environment. (Ahianba and Dimuna, 2008)

Thermal Comfort Considerations

The overcrowding, non compliance with building codes and poor ventilation conspire in the LIG housing to produce intense overheating, . This in turn results in widespread thermal discomfort: resulting in the following implications for LIG occupants:

- **Physiological Impacts of Overheating**
 - Excessive sweating, dizziness, Breathing difficulties, Stroke are just some of the physical manifestations of overcrowding and overheating of interior spaces. According to Ahianba (2008), the lifespan of anyone exposed to excessive heat for too long is shortened. It also has adverse effect on the skin, internal organs and physical well-being which may include their fertility. Resorting to the use of mechanical cooling devices to achieve comfortable interiors has resulted into huge amount of money being spent on the erratic power supply that is a norm in Lagos state. Acquiring Generators as an alternative has now resorted to being a necessity. Thus, their meagre income is further depleted by powering the generator and also contributing to global warming.

- **Psychological impacts**

Poor Concentration, irritability, Aggressiveness are some of the psychological manifestations of overcrowding. The Norm is to have an average of 4 -6 occupants in a 12sqm room. This results in a feeling of helplessness, lack of privacy and general discomfort. Indoor air quality is severely compromised. (Ahianba and Dimuna, 2008)

- **Mental impact**

Sleeplessness is a challenge among the low income group, due to a combination of overheating, overcrowding and general discomfort. This affects mental productivity especially among school children. The bulk of this group operate public transportation systems in which alertness is a key requirement for a safe operation, however, accidents are not uncommon due to the appalling conditions majority of the public transportation workers live in.

It is therefore argued here that one of the major challenges of low income housing is overheating (implication of climate change and global warming) and overcrowding. Currently, the challenge afforded by the former, is frequently addressed through the use of mechanical cooling and ventilation, although this is significantly limited due to financial affordability as well as occupants sleeping outdoors, where their personal security is at risk. It is argued here that Vertical Greening Systems, present a potential opportunity, providing passive cooling that might be embraced among these groups if this potential benefits can be evaluated and well presented. This is due to the numerous benefits associated with it ranging from vertical farming, aesthetics, enhancing thermal comfort etc. The VGS system can be seen as an aspect of urban renewal for existing houses. VGS is also known for its ability to enhance thermal comfort interior spaces. This is due to the transpiration of plants used in these systems.

Future Climate Comfort and Culture

Climate change is a continuous phenomenon. Countries like the UK are beginning to ensure strict protocols in the built environment so ensure reduction in carbon emissions. Kyoto agreement was signed in parts of Asia to ensure reduction in the contribution of global warming; however, decisive actions like these haven't been recorded in Nigeria. Therefore, urban heat island effect is becoming more prominent in commercial centres like Lagos; the implication is overheating in interior spaces leading to discomfort. The rural-urban migration which sees extended family members of Low income groups relocating to the city for perceived greener pastures does not seem to be abating. It is estimated that an average of 606 people enters Lagos per minute (Akinmoladun, 2004).

The challenge of coping with climate change is to develop sustainable means of responding to it. It is suggested that Vertical Greening systems, may present one such solution. Through the provision of passive thermal comfort improvement, they reduce reliance on energy and economically intensive mechanical cooling; which in the context of developing countries, including Nigeria, where the electricity supply in the country is insufficient and the use of generators is widespread; this would not only contribute to climate change mitigation, but also reduce localised airborne pollution and related health and comfort impacts.

Vertical Greening Systems



Plate 7: Vertical Greening Systems, Source: kirhammond.wordpress.com Accessed: Jan 2014.

Vertical Greening Systems (VGS) are also referred to as Living Wall systems, Green walls and vertical gardens are external or internal vertical greening elements that support a cover of vegetation which is rooted either in stacked pots or growing mats. (Dunnet and Kingsbury, 2004, cited in Perini, 2011). They could either be in the interior or exterior facades of buildings. Vertical green is the result of greening vertical surfaces with plants that may be rooted: into the ground; in the wall material itself; or in modular panels attached to the façade (Perini, 2011). Vegetation can be seen as an additive (construction) material to increase the multi functionality of facades of buildings. Vertical green, also commonly referred to as vertical garden is a descriptive term that is used to refer to all forms of vegetated wall surfaces (Ottele et al, 2011).

Conclusion/ future research.

Low income groups in Lagos survive on less than a dollar a day, (United Nations, 2010). Their average income is about N15, 000 a month (£58) (Aluko, 2004). Therefore the potential of VGS systems to offer financial savings from electricity bills will be of particular interest to this group.

The effect of climate change is continually being felt in the world. The means of coping with it is a challenge. Europe has adopted retrofit means of insulating houses thus reducing their energy loads for heating and cooling. , Kyoto protocols are being signed. However, in Nigeria, they has been no recorded action to protect houses from rising temperatures. This is mostly felt by low income groups who don't have the luxury of affording mechanical cooling devices. Electricity supply is also unstable, leading to general discomfort in houses. VGS has the potential to reduce indoor temperatures however; there is a dearth of research on VGS in tropical Africa. The potentials these systems offer in reducing indoor and surrounding environmental temperatures in Lagos will be the subject of further work for the author over the next 2 years. .This future study will also consider the financial impact of VGS on thermal comfort and slum upgrading. This will be evaluated through field work including measurement and user acceptability evaluation of the L.I.G groups towards these systems.

References

1. Abiodun, J.A (1997), Urban Growth Problems of Metropolitan Lagos in Time and Space. The urban challenge in Africa; growth and management in its large cities.pp 192-222.
2. Aduwo, E.B (2011), Housing Transformation and its Impact on Neighbourhoods in Selected Low Income Public Estates in Lagos, Nigeria. Ph D thesis, department of architecture, covenant university Ota.
3. Afolayan, S.A (2007), Private Sector Driven Housing Delivery: Issues, Challenges and Prospect. Department of Estate Management, University of Lagos, Nigeria.
4. Ahianba, J.E et al (2008), Built Environment Decay and Urban Health in Nigeria. Journal of Human Ecology. Vol. 23 No 3, pp 259-265.
5. Akinmoladun, O.I and Oluwoye, J.O (2007), An Assessment of Why Problems of Housing Shortages Persist in Developing Countries: A Case Study of Lagos Metropolis, Nigeria. Pakistan journal of social sciences, Vol.4, No.4, pp 589-598.
6. Aluko, (2012), Impact of Poverty on Housing Condition in Nigeria: A Case Study of Mushin Local Government Area of Lagos State. African studies and development, Vol.4, No.3, pp 81-89UN Habitat, (2012), National Trends in Housing Production Practices. United Nations centre for human settlements, Vol. Nigeria, pp 1-112.
7. Asbel, B (1975), the danger signals of crowding. Think magazine.pp 30-33.
8. Gambo, Y.L et al (2012), Impact of Poor Housing Condition on the Economy of the Urban Poor: Makoko, Lagos State in View. Emerging Trends in Economics and Management Sciences, Vol 3, No 5, pp 302-307.
9. Ilesanmi, A.O (2010), The Legacy and Challenge of Public Housing Provision in Lagos, Nigeria
10. Lawanson et al, (2012), The Home as a Workplace: Investigating Home Based Enterprises in Low Income Settlements of the Lagos Metropolis, ISOCARP congress, pp 1-12.
11. Lagos State Diary (1997), Lagos State of Nigeria: 1997 Office.
12. Odjugo, P (2010), General Overview of Climate Change Impacts in Nigeria. Journal of Human Ecology, Vol.29 No 1, pp 47-55.
13. Ojebode J and Gidado, K (2012), Potential of Using EAHX for Low Energy Cooling in Nigeria. Proceedings of EPPM2012, University of Brighton, UK, 10-11 September 2012.
14. Ojo, A.O (1998), Urbanization and Thermal Problems in Tropical Cities: The Lagos Experience. Evans (Nigeria) Limited. Ibadan, Nigeria.
15. Olotuah, (2005), Urbanization, Urban Poverty and Housing Inadequacy. African Union of Architect's congress.pp 185-199.
16. Olusanya, O (2012), Appropriate High Density Urban Housing Prototype for the Lagos Mega City: The Garden Atrium Apartment. Department of Architecture, University of Lagos.pp 7-12.
17. Ottelle, M et al (2011), Comparative Life Cycle Analysis for Green Facades and Living Wall Systems. Energy and Buildings. Vol. 43 No 12.pp 3419-3429

18. Perini, K at al (2011), Greening the building envelope, facade greening and living wall systems. Open journal of Ecology. Vol.1 No 1,pp 1-8
19. Yasmeen, G (2001), stockbrokers turned Sandwich Vendors: The Economic Crisis an Small Scale Food Retailing in South East Asia, Geoforum,Vol 32, No.1,pp 91-102.

WINDSOR CONFERENCE 2014

COUNTING THE COST OF COMFORT

CLOSING SESSION

WINDSOR CONFERENCE 2014

Invited Chair: Fergus Nicol

WINDSOR CONFERENCE 2014

COUNTING THE COST OF COMFORT

EXTRA PAPERS

PAPERS by authors unable to present

Exploring the Dynamic Aspect of Natural Air flow on Occupants Thermal Perception and Comfort

Harimi Djamila¹, Chi Chu Ming¹, Sivakumar Kumaresan¹

1 Universiti Malaysia Sabah, School of Engineering and Information Technology
harimi1@yahoo.fr, Fax: +6088320348

Abstract

The main purpose of this paper is to review the effect of the dynamic aspect of natural air movement on occupants' thermal comfort. Recent advanced investigations addressed the dynamic aspect of air movement in terms of turbulence intensity, probability distribution and power spectrum. This paper is not only about providing a thorough description and discussion on the underlying physical mechanisms of these factors, it is also about reviewing the effect of these parameters on occupants' thermal sensation, perception and comfort under different thermal conditions. Understanding the theoretical aspect of the fluctuating air movement and how it affects occupant thermal comfort specifically under hot-humid climatic conditions may yield to potential long-term savings and may reduce our demands for fossil fuels.

Keywords: Review, thermal comfort, fluctuating air movement, turbulence intensity

Several researches have been carried out on reducing energy consumption in air-conditioned spaces, but most of the investigations did not bring practical sustainable solutions. Additionally, many negative effects were reported when using air-conditioning such as "Non-adaptability of air conditioning", "Sick building syndrome" (Zhaoa et al., 2004). It has also been reported that the lack of stimulation due to a constant air flow such in air-conditioned spaces may induce the workers to become mentally disorientated and thereby decreasing their performance. Can some negative effects be avoided? This question has been raised by some investigators in building sector. Hara *et al.* (1997) stated that occupants do not usually feel well as they feel when exposed to natural breeze. This is because the sudden enhancement of heat flux movement from the human body causes a state of over-sense in thermal sensation and relaxes the discomfort (EL-Bezri, 2011). Kang *et al.* (2013) elaborates on this, fluctuating airflow brings more cooling effect to the human bodies, especially the fluctuating airflow with a frequency similar to that of natural wind. This will definitively helps in reducing energy consumption in air-conditioned buildings. In short, this also should lead to better adaptability toward air-conditioning. This is crucial in the humid tropics and in any location subjected to higher indoor air temperatures. This is even more important when we just consider the effect of the fluctuating air movement for passive cooling.

Several parameters were suggested and used to characterize natural and mechanical air flow. The parameters that are widely recognised include the turbulence intensity, probability distribution of air flow, in addition to spectral characteristics (Fanger *et al.*, 1998, Zhaoa *et al.*, 2004; Hara *et al.*, 1997; Arens *et al.* 1998; Kang *et al.*, 2013) and many others. However, little is known about how natural air movement affects

occupants' thermal perception. Till today we still do not know the true nature of natural air movement, and this precisely why several investigations over the world were conducted in the first place and still carried out today. What are the most crucial parameters that affect human desirability toward a specific natural air movement compared to another natural air movement when most of the parameters hold constants?

1 The Nature of the wind

In a macro-scale level, wind is the flow of a large body of air masses from the higher to the lower pressure area due to a difference in atmospheric pressure. It is mainly originated by temperature differences. The atmosphere has two distinct states of motion: laminar (Flow in a parallel direction) and turbulent (No specific dominant direction). Mixing occurs only in turbulent flow by dynamic mixing called turbulent eddies. Figure 1 shows a drawing of turbulence flow by Leonardo da Vinci. Note that part of the drawing has been removed for clarity.



Figure 1. Turbulent flow by Leonardo da Vinci (Storm)

On the surface of the Earth, the bulk movement of the air generates various winds speeds which change frequently in direction (Youm et al., 2005). It can be spatially and temporally described. Temporally, wind is characterized by long term and short term fluctuations. Long term fluctuations include hourly, daily, seasonal, annual and diurnal records. This will be discussed in section 4. Spatially, it is characterized by a three dimensional vectors (Gavriluta et al., 2012). Two-dimensional vectors are for describing the surface horizontal wind (i.e., East, West, North and South) and the vertical component for a complete three dimensional perspective. Figure 2 shows wind azimuth and elevation records on 6 April 2012. The raw data used for this analysis are available for download from Google. The files may be obtained by visiting: <http://code.google.com/p/google-rec-csp/downloads/list>. The data are freely provided by Google to anyone who may be interested. Approximately one sample was recorded every 0.13 seconds. The instrument used for data collection is RM Young 81000V, 3-axis ultrasonic anemometers. Figure 2 illustrates the variation of wind speed, azimuth and wind direction. It must be emphasised that the observed variation may not always occur in similar manner.

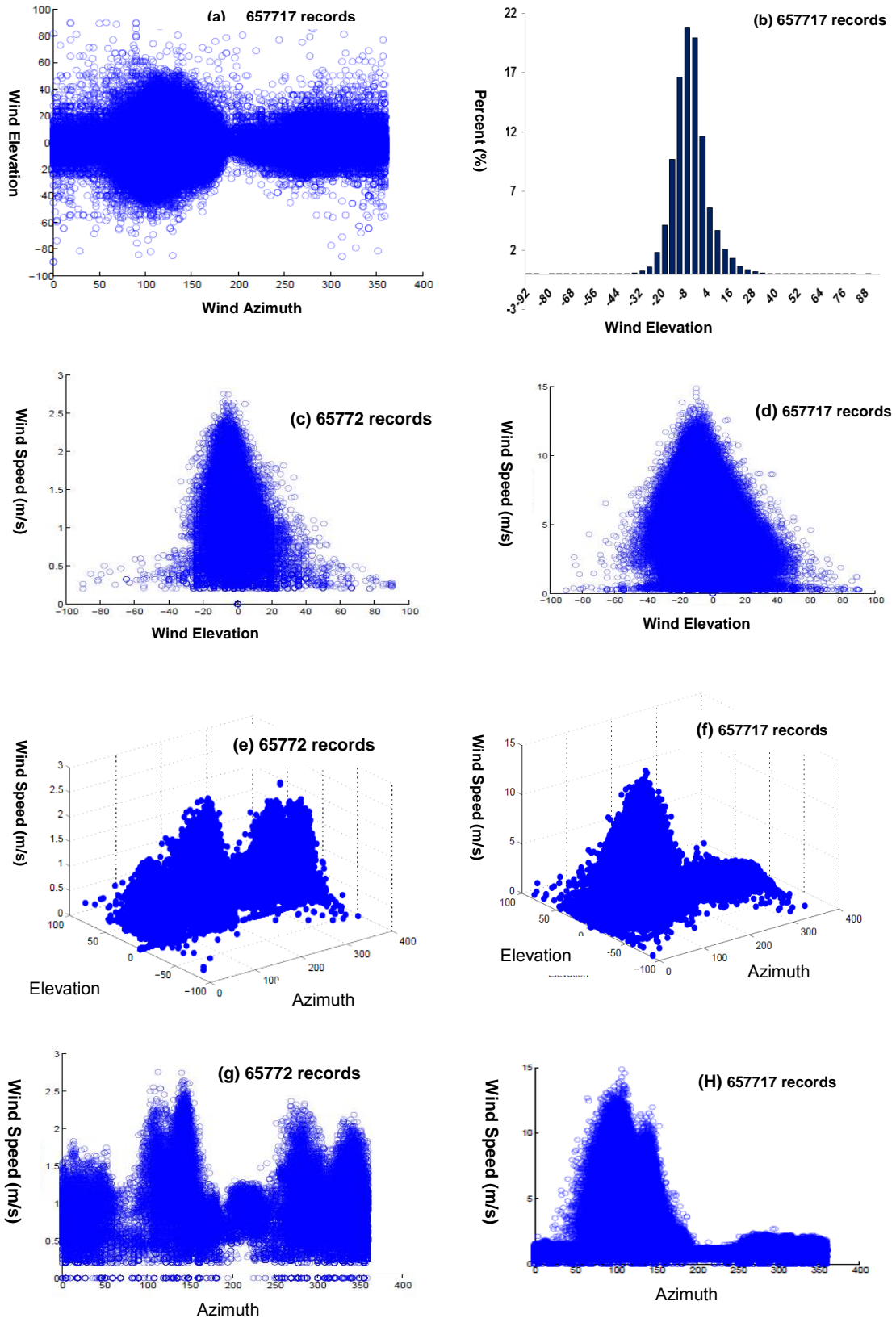

Figure 2. Variation of wind speed, azimuth and elevation
 Sampling Interval is about 0.13s.

The most striking feature of the observed variation in Figure 2 is the emerged patterns. A close look at Figure 2(a) reveals a specific symmetrical shape. Figure 2(b) provides further insight about the wind elevation. The variation of wind elevation was within a narrow range. The highest probability record was observed for the wind elevation of -12 degree. Data analysis revealed that the wind elevation was not normally distributed. About 439 low and 2095 high outliers were found. This might be occurred due to the presence of temporary objects which could distribute the wind pattern or for other factors. When the wind elevation was plotted versus wind speed in Figures (2c) and (2d), the obvious similarities between the two triangular shapes related to the first 10 minutes and the 60 minutes records were observed. This occurred despite the considerable differences in wind speed. For instance, the wind speed records in the first ten minutes were far below 3m/s, whereas for the 60 minutes records, the wind speed reached above 14m/s. Differences were also observed for the wind elevation. The higher is the wind speed, the more is close to the horizontal direction.

Fractals and chaos might provide a better interpretation of the results. Figure 2 (e) reveals the similarities of the 3D scatter plot between azimuth, elevation and wind speed. It is apparent that there are two grouped data which might exhibit similar patterns. This was noted for the short record of the first 10 minutes, whereas the situation is not the same for the one hour records. The same holds for Figures 2 (g) and (h).

The effect of the wind speed; direction and elevation on humans' thermal comfort may need further investigations for better understanding of the effect of the dynamic aspect of natural air movement on thermal comfort. This might be supported by Fanger et al. (1988) statement:

“As in the studies by Fanger and Christensen a **flow direction** from behind the subject was provided. This **seems** to be the direction at which **humans are most sensitive...**”

This also means that air movement may be perceived differently according to the wind direction. Earlier, Fanger et al. (1974) found no influence of the direction of air flow on creating thermal comfort. However, they found that the heat loss measured by the thermal manikin was higher when the air motion was from front (Simone and Olesen, 2013). One should be very careful for the conclusions made from experiments carried out in a controlled environment. This is because; it might not be similar to the field observation. In a nutshell external validation from field investigation is required.

Air movement as shown in Figure 2, can have several directions. It can be horizontal or from bottom to top, or top to bottom. According to a literature related to leave response to air movement in a controlled environment, it has been found that top to bottom air in controlled-environment rooms will more closely mimic humidity and temperature profiles found under field conditions (Robert et al., 1997).

It seems to be more interesting in thermal comfort research studies to mimic all the known climatic parameters that may provide pleasant thermal sensation in a controlled environment. This is because human being did not perceive air movement separate from other climatic parameters. For instance wind might be perceived draught in a cold environment but pleasant under hot environment. Figure 3 shows the fast variation of wind direction for the selected short record.

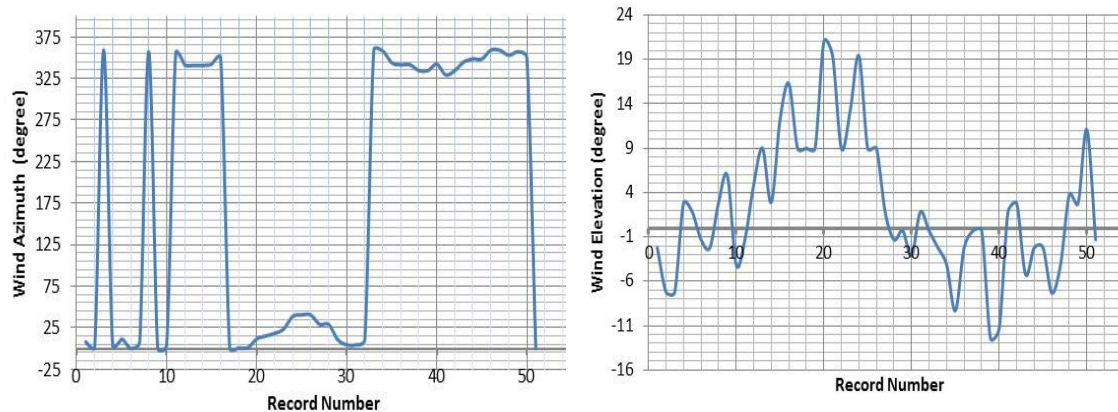

Figure 3. Variation of wind direction (Wind azimuth and elevation)
Air temperature was constant of about 58.4F (14.67C) (Sampling Interval is about 0.13 s)

2 The Characteristics of natural wind

Air flow is usually assessed in two ways, either as a time domain analysis or in the frequency domain as a power spectral density analysis. Time domain measures are the simplest to calculate. The main advantages of power spectral density analysis over the time domain measures is that it provides information on how the power (The variance) is distributed as a function of the frequency.

Since 1997 or even earlier, the Japanese investigators observed that natural wind has the feature of $1/f$ fluctuations (Hara et al., 1997). This is currently quite commonly known fact. $1/f$ fluctuations have also been found in biological systems. This type of fluctuation plays an essential role in preserving life in biological body (Musha and Yamamoto, 1997). The following is an interesting statement quoted from the same reference:

*“ ...It seems that the biological rhythm is basically subjected to $1/f$ fluctuations from cellular to behavioural levels....As regards biological phenomena, we often ask “How?” and “Why?”. The question of “why?” is still unsolved. “ $1/f$ fluctuations” was first found in **electric devices**, and now it is ubiquitous in nature. The physical “Why?” is still unsolved, but this phenomenon is **very basic in physics as well as in biology**”*

The acceptability of human to wind is connected closely to the stimulus of airflow on the surface of skin (Quyng et al., 2006). The human sensation toward air temperature and air movement may be explained by that, the hypothalamus receives information about skin temperature coded as **frequency** of nerve action. Huang et al. (2012) reviewed the effect of the frequency on human perception in more detail. They found that the airflows of 0.2 - 1.00 Hz had the stronger cooling effect on subjects (Huang et al., 2012). It must be emphasised that most of the investigations about the effect of frequency on thermal comfort were carried out in a controlled indoor climate for a limited indoor climatic range. Turning to thermal sensation, humans may sense air temperature and air movement according to their thermal and mechanical sensibility. For the thermal sensibility, the cold environment seems to be perceived stronger and faster than the hot environment. This is because there are more sensitive points at the skin level to cold than to hot (de Dear, 2010). The distribution density of cold sensors as reported by (Zhoo et al., 2004) is of 6-10 times than warm sensors and it is

unevenly distributed throughout the skin (Schacher et al., 2011). According to Schacher et al. (2011), mechanical sensibility depends on numerous parameters such as shape, surface, duration and intensity of the stimulus. Mechanical sensibility toward air movement might correspond to the human response to pressure (Wind speed), touch (might be related to our perception toward the fluctuating air movement) and as well as to vibration solicitations (might be connected to frequency).

Natural phenomena as described by Francesc (2010) usually have variability that is frequency dependent. The analysis of spectrum provides insight about the physical mechanisms that are behind (Francesc, 2010). Power spectral analysis is widely used in understanding the dynamic characteristics of airflow (Hara et al., 1997). It is inversely proportional to the frequency. In fact, Kang et al. (2013) added further insight about the term “1/f fluctuation”. It seems that (1/f) is also widely used to describe the mechanical air flow. They explained that

“Within the scientific literature, the term “1/f fluctuation” is sometimes used more loosely to refer to any fluctuation with a power spectral density of the form $E(f) \propto 1/f^\beta$, where f is the frequency and $0 < \beta < 2$, with β usually close to one”

Wind spectrum breaks sample variance of time series up into pieces, each of which is associated with a particular frequency. The function that describes turbulence as a function of frequency is known as a “spectral density function”. It is defined as the Fourier Transform of the autocorrelation sequence of the time series (Latawa, 2010). Fast Fourier Transform is quite known method but might not be necessary the most accurate (Latawa, 2010). Figure 4 exhibits a typical graph of the power spectral density of the wind speed. Usually the slope of the power spectral density of the wind speed is the most widely used to characterize natural wind from mechanical Wind. Fast Fourier Transform was used for the prediction.

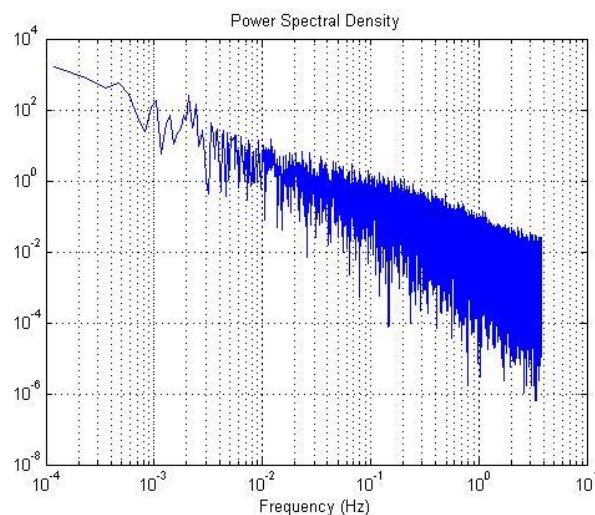

Figure 4. Power Spectral Density (Wind Speed, azimuth and elevation)
Sampling Interval is about 0.13 s.

It must be emphasised that several approaches have been developed to estimate the spectrum from an observed time series, Periodogram, Burg, Covariance, Modified Covariance, Thomson Multitaper method, Welch, Blackman-Tukey and many other methods (Latawa, 2010; Apt, 2007; Chatfield, 2004; Bloomfield, 1976). However, little is known about the spectral analysis algorithms used by many investigators in

characterising air movement. Therefore, it is hoped that this observation will be considered so that comparison among studies will be meaningful. A clear systematic accurate approach will certainly help to concentrate in solving other issues and therefore advancing faster and better in thermal comfort science.

Returning back to the discussion about the differences and similarities between natural and mechanical wind in built environment; Quayang et al. (2006) found that the slope of the curves for natural wind was steeper than that of mechanical wind. Further, Kang et al. (2013) also observed from their field investigation in a mountain subjected to a hot and humid environment that comfortable wind has a steeper slope compared to uncomfortable natural wind or mechanical wind ($\beta_{\text{comfortable}} > \beta_{\text{uncomfortable}}$). Thus we may assume that under hot humid conditions, the steeper is the slope of the curve of the logarithmic power spectrum of the wind, the more is desirable. It is necessary to highlight that the present assumption should not be generalised for lack of validation. Quayang et al. (2006) observed that the slope of the power spectral density (beta value) of the wind speed increased with the elevation of the mean velocity. This is for the seashore case study only, but the two parameters were not correlated for the following cases: outdoor open area, on the roof of the building, around the building and indoors. The reasons of discrepancies were not reported and seem to be unknown. Additionally, wind speed records for the investigation carried out by Kang et al. (2013) were not normally distributed. Here, we may raise an interesting question: How far such deviation from normality might affect the estimated mean and therefore the conclusions made by the investigators?

Before passing to the next section, it must be emphasised that fractals, wavelet transformations, phase reconstruction map and other complex methods for the characterisation of the wind speed have been used by some investigators (Dear et al. 2013). However, due to the limitation of the space and the availability of the time such complex methods will be reviewed in the future mostly from the available English publications.

3 Mean Wind Speed versus Fluctuating Wind Speed

The wind speed at a fixed point can be divided in two components: the mean speed and the fluctuating wind speed. The mean velocity is insufficient to describe accurately humans' thermal perceptions, specifically when subjected to a fluctuating air movement. Earlier in 1973, Fanger stated the following:

“The mean air velocity and the air temperature are, of course, of importance for convective heat transfer and they should be balanced according to the comfort equation. But the mean velocity is not sufficient to explain the draught phenomenon. Man can be comfortable at quite substantial air velocities (i.e., 1m/s) provided that the ambient temperature is adjusted to a suitable level.... Other aerodynamic magnitudes might be important....”

We may add the mean velocity is not also sufficient to explain the desirability toward fluctuating air movement. Figure 5(a) shows the high variation of the mean wind speed records for the selected sampling interval of one second. The selected duration is one minute. Figure 5(b) depicts the smooth variation of the mean wind speed for the selected sampling interval of ten minutes. The graph portrays the wind variation during one hour.

The variation of the wind when considering the extreme lowest and highest values (The height of the wave) reached up to 0.5 m/s within an interval of 40 seconds. This

was only one single observation and therefore it might be even higher in other cases. This reflects the complexity in predicting the effect of air movement on human thermal comfort. But what are the consequences of this observation? The answer seems to be difficult. In fact there are others questions need to be addressed. For instance, does the effect of air movement perceived by the subject prior filling in the questionnaire affects subject decision? Taking as an example the situation faced by the psychologist related to human perceptions and adaptations, we found the following (Zimbardo et al., 2003)

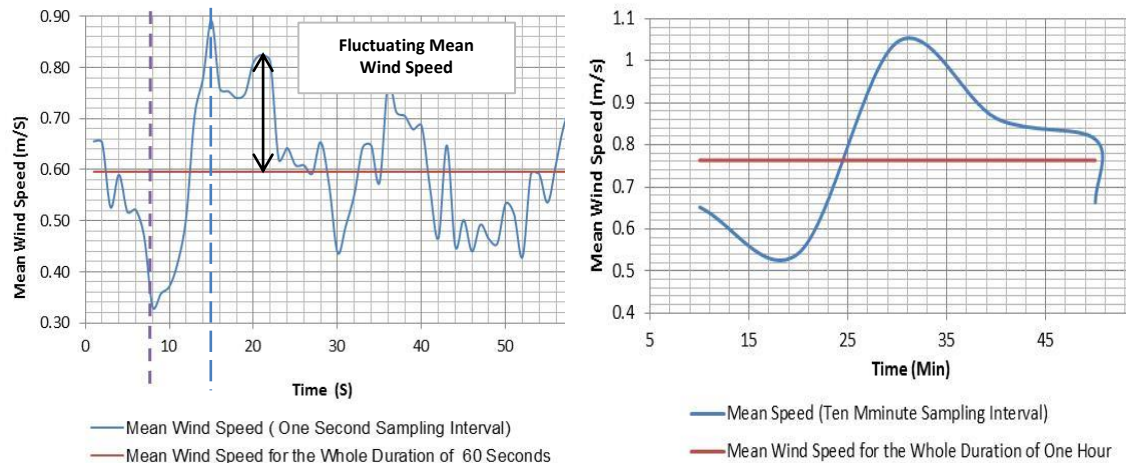

Figure 5. Variation of wind speed over time

*“Signal theory recognizes that the **observer, whose physical and mental status is always in flux, must compare a sensory experience with ever-changing expectations and biological conditions.** This contradicts the classical psychophysics which states that if the signal were intense enough to exceed one’s absolute threshold, it would be sensed; if below threshold, it would be missed...Sensation is not a simple present/absent, “yes/no” experience”*

Human adaptation seems to be a continuous dynamic process and our perceptions toward thermal environment parameters will be always based on what we experienced in the past. This means that humans might not have similar desirability toward natural air movement all the time. This adds more complexity to the raised issue. It must be emphasised that no thermal comfort data have been presented to provide evidence related to this assumption. However, it might be possible with the current available technology to address the issue in a systematic simple way. In our opinion for more accurate prediction, an online questionnaire may provide the precise time records of subject’s response during a conducted survey. The subjects should be informed to provide an instantaneous answer. The automatic records have a double advantage in reducing other possible errors that may be induced due to the manual records. Additionally, 3D ultrasonic anemometer or other accurate instruments which records wind speed, direction and elevation with high accuracy and fast response may provide better measurements and further insight. According to Schacher et al., (2011), the human sensory response is generated after 0.1 to 0.2 second after the simulation. The response to a sensory stimulation could be physiological, behavioural, verbal, or psychological. Therefore, continuous records of air movement for about 15 to 30 minute prior and during the time of filling in the questionnaire by the subject is necessary for an accurate interpretation of the results.

Many anemometers are also available for instantaneous air movement measurements. However the main limitation of **most** of them is that they do not necessary records air movement accurately from all directions. The measurement error can reach up to **50% according to the orientation of the hot-wire** (Robert et al.,1997). The instrument may interface with air movement which will affect the records.

Several crucial recommendations were provided in the reference by Robert et al., (1997) for the selection of the anemometers and therefore we will not repeat most of the recommendations here. However, the calibration when using wind tunnels must be addressed. It is widely accepted in thermal comfort investigations that wind tunnel provide better calibration. Unfortunately, this is not always true. According to the same reference, **most** wind tunnels operate poorly below 1 ms^{-1} . The reader may refer to the authors' publication (Open Access) for further insight about the why and also for the selection of the most appropriate method for the calibration. A laser Doppler anemometer can also be used to measure the velocity at a point in a flow using light beams which does not disturb the flow being measured. This instrument provides accurate measurements. Ultrasonic anemometer is also widely used device to evaluate turbulent parameters such as mean air velocity, turbulence intensity and integral length scale (López et al., 2011). The advantage of using an ultrasonic anemometer is that, it can also test both the mean wind speed and the fluctuating component (Yin et al., 2013). It allows also the measurement of very low air velocities as well.

3.1 Mean wind speed

The arithmetic mean value of wind speed has been widely used for investigating the effect of air movement on occupants' thermal comfort. In fact turbulence intensity requires knowledge of the mean value for the selected period. However, a mean value may not be the prevalent air movement. In addition, air movement in many cases is not normally distributed. It is mostly skewed and therefore the predominant wind speed might be lower than the mean value. The median estimate is preferred for non-symmetrical distributions. However, transformation of the data might help in correcting the degree of skewers prior estimation of the mean. The Weibull distribution is well accepted and widely used for wind data analysis. Robin Roche (2013) developed a Matlab script to compute the Weibull distribution parameters from a wind speed time series. Some important recommendations and references can also be found in the script. Therefore a preliminary data analysis might help to get better information about the collected data prior analysis. Figure 6 illustrates the probability density and the linearized curve and fitted comparison of the wind speed for the first 65772 records using Robin Roche (2013) script. The histogram shown in the same figure was generated using Matlab. From the figure, it is apparent that the wind is skewed to the right.

Other distributions may provide even better predictions for the description of the collected data. The reader may refer to the Easy-fit 5.5 professional software (free trial) or any other reliable references. It must be emphasised that the final selection of the wind distribution should be based on the goodness of fit tests. This can also be found in the software. Unfortunately, the analysis for the free trial is limited to 500 records only. Therefore, the software was not used for illustration. Among the available tests provided in the software are; Kolmogorov-Smimov, Anderson-Darling and Chi-Squared Tests. These can be used to test how well a theoretical probability distribution fits the collected data. It is necessary to mention that it has been reported that Weibull distribution did not take into consideration the dependence structure of wind observations. The weibull distribution assumes the randomness of the data.

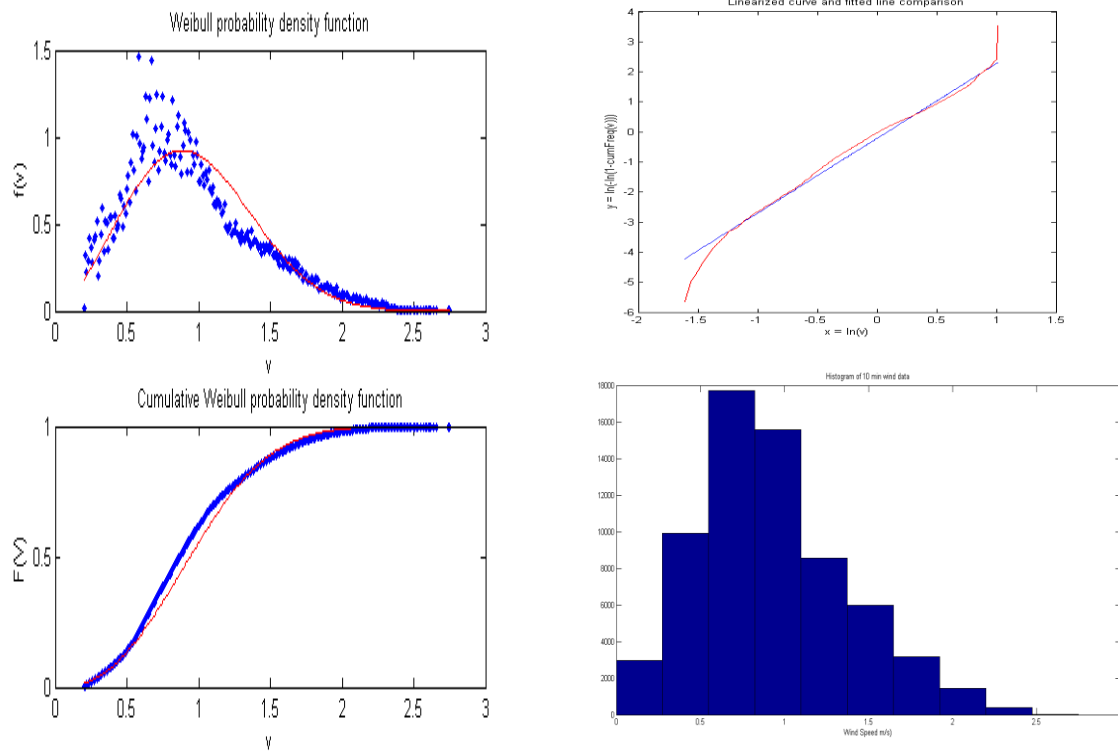

Figure 6 Probability density and Histogram of Wind Speed.
About 65772 records were considered for this plot

Hara et al. (1997) in their interesting investigation reported that the fluctuation of natural wind has some chaotic properties. According to Fei et al. (2013):

Natural wind is random and irregular macroscopically while it contains different scales swirls with self-similar structure microscopically, reflecting Chaos feature of turbulence....it means that a seemingly chaotic and disorganised graph has a fine structure, which is called the self-similar structure, mainly expressing an intrinsic geometric regularity, that is, the self-similarity of proportion”

To sum up, a careful analysis of the prevailing wind speed is necessary prior investigating the effect of the wind speed on occupants’ thermal perception and comfort.

Finally, comparison of one hour wind speed averages (black) with data samples for wind speed at 7.6 Hz (green) is illustrated in Figure 7. This figure provides evidence of the importance for tracking actual wind speed data instead of relying on averages as exactly stated in reference (<https://code.google.com/p/google-rec-csp/downloads/list>). It is apparent from the figure that the instantaneous wind speeds have a clear band around the means. This may help in investigating subjects’ perception toward air movement according to the band (range) as well. The wind pattern inside a room may not be similar to the outdoor environment. However, this observation is useful when mimicking the natural air movement in a controlled environment or for outdoor thermal comfort investigations.

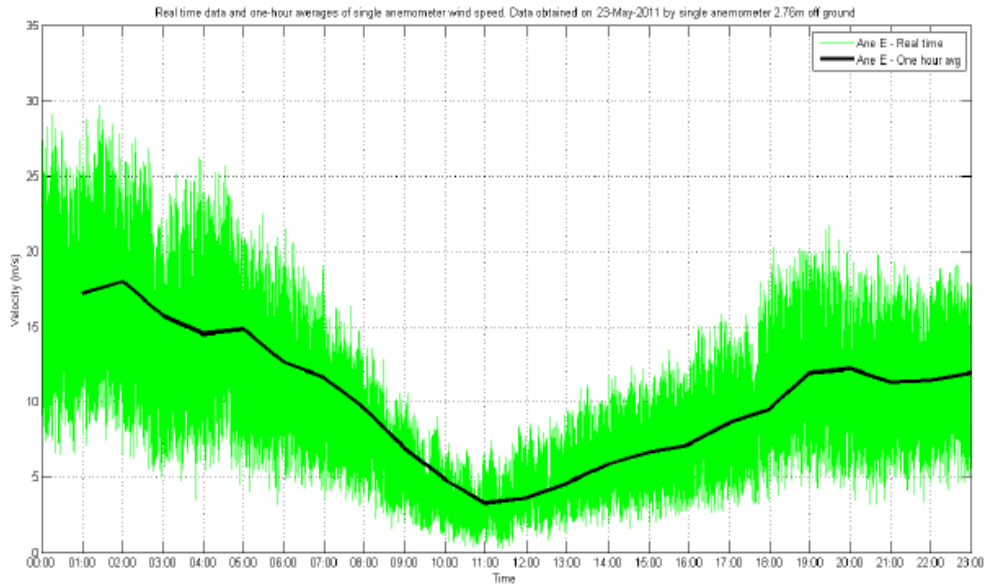

Figure 7 Sampled wind data at 7.6 hz (Green) vs 1-hour averages
 (Source of this plot: <https://code.google.com/p/google-rec-csp/downloads/list>)

3.2 Turbulence intensity

Mean speed is often referred to as quasi-steady mean speed. Short term fluctuation is mostly used for the description of the turbulence and wind gust over a short period of time. It is typically less than 10 minutes (Francesc, 2010). Gust factor is referred to a rapid increase in the strength of the wind relative to the mean strength at the time. It is defined as the ratio between a peak wind gust and mean wind speed over a period of time (Paulsen and Schroeder, 2005) which depends on gust duration. The longer is the duration, the smaller will be the gust coefficient (Yin et al., 2013). It has been reported that greater turbulence intensity is associated with the larger gust factor. It is considered an important factor in addition to other statistical wind parameters to describe the structure of the wind. Gust is highly reliant on the terrain characteristics (Paulsen, Schroeder, 2005). However, it is the least considered in describing the dynamic aspect of air flow in thermal comfort studies. The gust speed and direction are defined by the maximum three second average wind speed occurring in any period (NMLA, 2013). It is sampled at high frequency (0.25sec) to catch the intensity of gusts which are described as short-lived peaks in speed. These cause greatest damage in storm. Wind direction, speed and gustiness are generally determined instrumentally. According to U.S. weather observing practice, gusts are reported when the peak wind speed reaches at least 16 knots (8.2 m/s) and the variation in wind speed between the peaks and lulls (lulls means calm: a period without waves or wind) is at least 9 knots (4.6 m/s). The duration of a gust is usually less than 20 seconds according to the same source. However, such wind intensity is of no interest in thermal comfort field investigations.

A turbulence flow is mostly defined as a continuous three dimensional flow of many dynamic moving eddies (vortices) of different sizes and strengths reflecting chaos feature of turbulence (Yin et al., 2013). Turbulence occurs due to wind shear which arises in the boundary between air volumes with different velocity. Turbulence may also occur due to mechanical forces between the moving air and an obstacle (i.e. friction with the ground surface, barrier such building and forest, topography of the

site, water). This results in deflection of the flow of the air (Nicole, 2011). Convection affects the turbulence of air flow (Hoven, 1957) due to the thermal effects that causes air to move vertically. The fluctuations occur in all the three directions (Francesc, 2010).

Turbulence intensity is also defined as the ratio of the standard deviation of velocity to the mean velocity for a given time history of air velocity (Aynsley 2008). It is often multiplied by 100 to give a percentage expression (Marcel, 1998). An idealized flow of air with absolutely no fluctuations in air speed or direction would have a Turbulence Intensity value of 0%. Because the turbulent motions associated with eddies are approximately random, we can characterize them using statistical concepts. Statistically, the turbulence intensity is defined as the standard deviation by the mean velocity (Fanger et al., 1988)

$$x = \frac{\sqrt{v'^2}}{\bar{v}} = \frac{\sigma}{\bar{v}} \quad (1)$$

Where

σ is the standard deviation.
 v' is the instantaneous air velocity
 \bar{v} is the mean wind speed

Looking at this equation, it can be seen that the larger the mean air movement is, the larger the denominator will be and therefore the turbulence intensity will be smaller. So what sample size would be recommended in thermal comfort field investigations? So, it depends on the effect that is being investigated, however ten minutes are widely used in estimating turbulence intensity. Hara et al. (1997) made an important conclusion from their research investigation which was that the rapid increasing wind velocity was found to be more comfortable than slowly increasing one. Of course, this seems to be in agreement with common sense as well. One may need just to drive a car in a windy hot day to understand how rapid increase in air movement provides a desirable sensation. The sudden or rapid variation in air movement (from extreme minimum to extreme maximum in a very short period of time) probably might not be well described by turbulence intensity. This is because the standard deviation provides an average fluctuation above or below the mean. Further investigation in that direction is worth pursuing in a more focussed study

4. Conclusions

Many observational studies have been conducted for exploring the characteristics of air flow based on short and long term observations. Exploring the characteristics of air flow on human thermal perception is of interest of thermal comfort field investigations and was the main objective of this review. The following are the main conclusions:

- (1) The mean velocity is not sufficient to explain the desirability of subjects' thermal perceptions toward natural air movement.
- (2) The arithmetic mean value of wind speed has been widely in thermal comfort studies. Air movement might not be normally distributed. The knowledge of the distribution of the data is important before data analysis.
- (3) Wind direction and elevation were very seldom considered in thermal comfort field investigations. Those parameters require further investigation.

- (4) Turbulence intensity may not describe fully the sudden increase of the fluctuating air movement on humans' thermal perceptions. Further investigation in that direction is worth pursuing in a more focussed study.

Acknowledgements

The authors wish to thank google.org for making the wind speed records available from which Figures 2 to 6 were made.

The work of this paper is financially supported by the Universiti Malaysia Sabah (SBK0083-TK-2013)

References

- Arens, E., Xu, T., Miura, K., Hui Z., Fountain, M. and Bauman, F., 1998. A Study of Occupant Cooling by Personally Controlled Air Movement. *Energy and Buildings*, 27, pp 45-59.
- Aynsley, R. 2008. Air Movement for Energy-Efficient Summer Comfort: GreenCE, Inc.
- Apt, J., 2007. The Spectrum of Power from Wind Turbines. *Journal of Power Sources*, 169, pp 369-374.
- Bloomfield., 1976. *Fourier Analysis of Time Series*. Canada: John Wiley & Sons.
- Chatfield, C., 2004. *The Analysis of Time Series*, sixth edition: New York, Chapman & Hall/CRC.
- Chiang, H.C, Pan, C. S., Wu, H.S. and Yang, B.C., 2007. Measurement of Flow Characteristics of a ceiling Fan with Varying Rotational Speed. *Proceedings of Clima 2007 WellBeing Indoor*, Helsinki, Finland.
- de Dear, R. 2010. Thermal Comfort in Natural Ventilation - A Neurophysiological Hypothesis. *Windsor Conference: Adapting to Change: New Thinking on Comfort*. London, Cumberland Lodge, Windsor, UK, 9-11 April 2010, *Network for Comfort and Energy Use in Buildings*..
- EL-Bezri, M. O., 2011. *The influence of Wind on Outdoor Thermal Comfort in the City of Beirut: A theoretical and Field Study*. Msc. American University of Beirut.
- Fanger, P.O., 1973. Assessment of Man's Thermal Comfort in Practice. *British Journal of Industrial Medecine*, 30, pp 313-324.
- Fanger, P.O., Ostergaard, J., Olesen, S., Lund Madsen, T.H., 1974. The effect on Man's Comfort of a Uniform Air Flow from Different Directions. *ASHRAE Transaction*, 2, pp142-157
- Fanger, P.O, Melikov, A.K., Hanzawa, H. and Ring, J., 1988. Air Turbulence and Sensation of Draught. *Energy and Building*, PP 21-39.
- Francesc, A. J., 2010. *Wind Power Emulator for Energy Storage*. Master Thesis Report, Aalborg Universitet, Denmark.
- Gavrilita, S., Spataru, I., Mosincat, C., Citro, I., Candela, P., Rodriguez, 2012. Complete Methodology on Generating Realistic Wind Speed Profiles Based on Measurements. *International Conference on Renewable Energies and Power Quality*, Santiago de Compostela, Spain, 28-30 March, 2012. European Association for the Development of Renewable Energies, Environment and Power Quality

Hara, T., Shimizu, M., Iguchi, K. and Odagiri, G., 1997. Chaotic Fluctuation in Natural Wind and its Application to Thermal Amenity. *Nonlinear Analysis, Theory, Methods and Applications*, 30, pp 2803-2813

Hoven, I.V.D., 1957. Power Spectrum of Horizontal Wind Speed in the Frequency Range from 0.0007 to 900 Cycles per Hour. *Journal of Meteorology*, 14, pp 160-164

Huang, L., Quyang, Q. and Zhu, Y., 2012. Perceptible Airflow Fluctuation Frequency and Human Thermal Response. *Building and Environment*, 54, pp, 14-19

Kang, K., Song, D. and Shiavon, S. 2013. Correlations in Thermal Comfort and Natural Wind. *Journal of Thermal Biology*, 38, pp 419-426

Latawa Anchali, 2010. *Estimation of Power Spectral Density in Different Frequency Bands*. MSc, THAPAR University.

López A., Valera D. L., and Molina-Aiz F., 2011. Sonic Anemometry to Measure Natural Ventilation in Greenhouses. *Sensors*, 11, 9820-9838

Marcel L. 1998. *The Measurement and Simulation of Indoor Air Flow*. PhD Thesis. Eindhoven University of Technology.

Musha, T., and Yamamoto, M., 1997. 1/f Fluctuations in Biological Systems. *Proceedings – 9th International Conference –IEEE/EMBS*. Chicago, 30 Oct-2 Nov 1997. Engineering in Medicine and Biology Society.

Nicole C., 2011. *Turbulence Intensity in Complex Environments and its Influence on Small and Wind Turbines*. Sweden: Nicole Carpman and the Department of Earth Sciences, Uppsala University.

NMLA (The National Meteorological Library and Archive). *Weather Observations over Land* (Version 01). WWW.Metoffice.gov.uk/learning/library. Retrieved from Internet Dec 2013.

Paulsen, B. M., Schroeder, 2005. An Examination of Tropical and Extra-tropical Gust Factors and the Associated Wind Speed Histograms. *J. Appl. Meteor.*, 44, pp 270–280.

Quyang, Q., Dai, W., Li, H. and Zhu, Y. 2006. Study on Dynamic Characteristics of Natural and Mechanical Wind in Built Environment using Spectral Analysis. *Building and Environment*, 41, PP 418-426

Robert, J.D., and Donald, T.K. 1997. *Air Movement*, In: Plant Growth Chamber Handbook, Langhans and Tibbitts (Ed.), IOWA State University of Science and Technology.

Robin Roche., 2013. *Computing Weibull Distribution Parameters from a Wind Speed Time series*: Matlab Central, http://www.mathworks.com/matlabcentral/fileexchange/41996-computing-weibull-distribution-parameters-from-a-wind-speed-time-series/content/weibull_distrib.m

Schacher, L., Bensaid, S., Jeguirim, S.E., Adophe, D., 2011. Sensory and Physiological Issues, *Advances in Modern Woven Fabrics Technology*, Dr. Savvas Vassliadis (Ed.), In Tech.

Simone and Olesen, 2013. Preferred Air Velocity on Local Cooling Effect of desk Fans in Warm environment. *Proceedings of 3th AIVC- 4th TightVent- 2nd venticool Joint Conference*, Athens, 25-26 September.

Yin, F., Zhou, J., S., Zhang, G., 2013. Study on Unsteady Characteristics and Field Measurement of Natural Wind. *APEC Conference on Low-carbon Towns and Physical Energy Storage* Changsha, China, 25-26 May 2013. ACLE

Youm, J., Sarr, M., Sall, A., Ndiaye and Kane, 2005. Analyses of Wind Energy along the Northern Coast of Senegal. *Rev.Energ. Ren*, 8 pp 95-108.

Zhaoa, R., Sunb, S., Dingc, R., 2004. Conditioning Strategies of Indoor Thermal Environment in Warm Climates. *Energy and Buildings*, 36, pp 1281–1286.

Zimbardo, P.G., Weber, A.L. and Johnson, R.L., 2003. *Psychology Core Concepts*. Boston: Philip Zimbardo.

Mobile Meteorological Survey Station: Applying Measurement Tools on a bike to create the Meteobike

Patricia R C Drach^{1,3} and Henrique Drach²

1 Sustainable Urban Environments, School of Engineering and Built Environment
Glasgow Caledonian University, Glasgow, United Kingdom, patricia.drach@gmail.com;
2 Fluminense Federal University – UFF, Niterói, Brazil; henriquecello@hotmail.com;
3 CNPq Researcher, Science without Borders, Brazil

Abstract

This paper presents a logistic proposal for the research project related to thermal comfort in Rio de Janeiro's open spaces. Part of the investigation consists of collecting weather data and applying a thermal sensation survey to pedestrians in Rio de Janeiro city's centre. The weather station used is a Davis-Pro2, composed by a cylindrical module body moulded on plastic and sustained by a central tube attached to a tripod, both in galvanized iron. The fieldwork dynamics requires data collection in different points, therefore, involving the constant transportation of the equipment throughout the city. Carrying the equipment in a big town generally implies travelling long distances with a heavy and bulky cargo by using public transport or a car, creating pollution, facing traffic problems and dealing with lack of adequate parking spaces. The idea of attaching the station to a bicycle came naturally to the two researchers. The system, as idealized, has proven to be efficient, providing practicality, lightness and mobility in data collection, coupled with the advantage of being a non-polluting transportation. The bike name 'Meteobike' was suggested by many respondents.

Keywords: Meteorological Station, Urban Microclimate, Meteobike, Measurements Facilities

1 Introduction

The growing concern about the environmental phenomena has promoted an increase of studies related to the urban heat island (UHI) formation in several research areas that correlate the human being with the climate. These heat islands can be defined as urban areas with higher temperatures than in neighboring regions and their formation is a result of the interaction of various factors, and for its study it becomes important to have a broader view of the problem. There are many variables involved in the UHI generation process and it is important to take into account the largest possible number of them.

Large concentrations of buildings in cities mean a very large amount of solar radiation absorbing surfaces, facilitating the emergence of (along with pollution) heat islands, particularly noticeable at night, when the material of the buildings dissipates the heat stored during the day.

UHI has negative effects ranging from environmental discomfort until the energy consumption increase, which represents a high financial and environmental cost. This increase is due to the need of use of refrigeration and air conditioning equipment, to provide users of the built environment in these regions the proper comfort level. Thermal energy poured into the outer space by apparatus feeds back the phenomenon, producing in turn a higher consumption of electricity.

The theoretical and practical interest in this subject comes from the need to establish the best relation between ventilation intensity and solar radiation for a specific region, according to the climate conditions, not inducing urban heat islands formation. When determining the parameters such as wind velocity and air temperature to define these areas it is possible to use some simulation tools seeking at least some degree of prediction of trends for each study area. Initial studies from Drach et al. and Carneiro et al. (Drach et al, 2013; Carneiro et al, 2012) indicate the ability to interfere with air circulation, for example, by changing the location or shape of obstacles, the urban cover materials and introducing greenery.

Thus, through simple changes in some cases it may be possible to mitigate the effects of UHI. For example, the introduction of green areas, both for production and for aesthetic uses, can also improve and minimize the negative effects of heat islands, and contribute positively to the urban landscape. The effectiveness of any recommendations to minimize or sometimes resolve the problem seems to be proportional to the support found in society, administration and local governments.

Experimental and computational studies to evaluate alterations in ventilation from changes in urban morphology were developed in Wind Tunnel at the Faculty of Architecture and Urbanism of the Federal University of Rio de Janeiro (Drach et al, 2013; Carneiro et al, 2012) and also using the software ENVI-Met (Bruse, 2009), software developed for climate simulations in urban areas (Barbosa et al, 2010a; Barbosa et al, 2010b), respectively. These studies showed the ability to increase ventilation and reduce the temperature from the introduction of greenery and changes in urban morphology. This work, however, focuses mainly on studies of thermal comfort in open spaces in the city of Rio de Janeiro and complements the computational and experimental studies, previously developed. It also presents the possibility of making systematic data collection through the use of weather station and survey about thermal sensation applied to users of open spaces. The production of this database will allow the analysis of data collected for the city of Rio de Janeiro, also allowing further comparisons with the responses previously obtained using the same methodology, to the cities of Curitiba and Glasgow (Krüger et al, 2012a; Krüger et al, 2012b; Krüger et al, 2011), both with climate, in terms of urban areas, and quite distinct local population.

Currently fieldwork campaigns are being implemented for collecting meteorological data and information about thermal sensation. The research is being conducted in pedestrian streets in the city centre area of Rio de Janeiro. Seven stop points were defined according to the differences observed in urban form, for example, height and proximity of buildings, presence of vegetation, squares etc. Here these differences are represented by the sky view factor - FVC. For the determination of the SVF, fisheye images at each monitoring point were taken using a fisheye lens Sigma 4.5mm f 2.8 EX. From the fisheye images, the SVF and 'solar path' were calculated using the computational tool, Rayman-pro (Matzarakis, 2013). The relationship between the sky view factor in urban canyons and the air temperature was noted in previous studies (Taha, 1988).

This paper presents a logistic proposal for the research project related to thermal comfort in Rio de Janeiro's open spaces. Part of the investigation consists of collecting weather data and applying a thermal sensation survey to pedestrians in Rio de Janeiro city's centre. The weather station used is a Davis Pro2, equipped with temperature and humidity sensors, cup anemometer with wind vane, silicon pyranometer and globe thermometer. This station is composed by a cylindrical module body moulded on plastic and sustained by a central tube attached to a tripod, both in galvanized iron.

The fieldwork dynamics comprises data collection in different stop points of the city centre, therefore, involving the constant transportation of the equipment throughout the city. Carrying the equipment in a big town generally implies travelling long distances with a heavy and bulky cargo by using public transport or a car, creating pollution, facing traffic problems and dealing with lack of adequate parking spaces. Being cyclists, the idea of attaching the station to a bicycle came naturally to the two researchers. The bicycle used is a Tandem Recumbent Zöhrer model, previously owned.

From observations of the behaviour of thermal sensation survey associated to microclimatic conditions it could be possible to devise strategies such as, shading, proper use of vegetation or other urban elements, in order to improve the qualities of the pathways studied as a way to try to minimize the external discomfort. So, the main objective of this proposal is to study the general human response of local people to climate particularities of Rio de Janeiro City and determine some intervention strategies in urban morphology that could lead to improvement of environmental comfort.

2 'Meteobike'

The system, as idealized, has proven to be efficient, providing practicality, lightness and mobility in data collection, coupled with the advantage of being a non-polluting transportation. The bike name was suggested by many respondents that referred to a 'meteorological bike', which was shortened to 'Meteobike' (Figure 1).



Figure 1. The 'Meteobike' in Copacabana Beach, Rio de Janeiro, Brazil.

When biking to the collection point, the station can be positioned at the lower end of the tube, leaning over the trunk and wrapped in absorbent material to avoid impacts. As a precaution against possible accidents, currently a Styrofoam kit is used, but it is planned to build one in fiberglass. Thus, it was possible to improve the system, giving lightness (to get rid of heavy galvanized iron tripod) and mobility at the same time.

The problem of providing stability to the weather station set over the bike, once parked at the collection point, was solved by the making of a 'centre stand' in aluminium (not to add more weight to the set, since the models found in bike stores are usually made of cast iron) similar to those used in motorcycles. Thus, in Figure 2 it can be seen the 'centre stand' on aluminium, designed and built by the researchers. Part of the twisting force on the bike frame is relieved by supporting the rear wheel on the centre stand (Figure 2a). There were still the two tasks, namely, to deal with the usual possibility of uneven floors and to give lateral stability to the whole set. The first was solved by a system allowing the adjustment and longitudinal

displacement of the rack to which the tube (shaft station) is set, as well as the transverse displacement of the same tube. Thus the station can be positioned plumb, which is its ideal working position. The second was solved by setting up across a long aluminium tube at the centre stand.



(a) support for station (b) aluminium designed and built by the researchers.

The 'Meteobike' has been tested during the 16 campaigns in Rio de Janeiro city, Brazil, and along the 39 campaigns in Glasgow city, UK. In all of these campaigns the 'aluminium stand centre', similar to those used in motorcycles, proved to be able to withstand the cycling set and the weather station giving firmness and stability to the assembly. When standing at a stop point, the 'Meteobike' performs as the tripod supporting the meteorological station and its correct position is adjusted using a spirit level.

3 Area of Study

The region of the city of Rio de Janeiro is located in the administrative center of Region 2 and belongs to City Centre Council covering the districts of Catumbi, Cidade Nova, Estácio, Gamboa, Glória, Praça da Bandeira, Santo Cristo, Saúde. The occupation of this region occurred with the beginning of the city of Rio de Janeiro and, despite the constant changes imposed on the area, it still has an important historical and cultural heritage of the city.

All selected points for measurements and surveys are located in the pedestrian streets in the city centre of Rio de Janeiro. The streets have vehicle access allowed only for services (deliveries and withdrawals of goods and other related maintenance activities of trade, offices, businesses, etc.), thus not having a steady stream of cars or traffic. In Table 1, the population numbers of the study area are presented according to the IBGE Census 2010, and these values are interesting for understanding the population dynamics of the region.

Table 1. Population - City and central area of Rio de Janeiro.

	Total
Rio de Janeiro city	6.323.037
Central area	41.142

IBGE censo 2010 - http://www.ibge.gov.br/home/estatistica/populacao/censo2010/tabelas_pdf/total_populacao_rio_de_janeiro.pdf

From these data it can be seen that this is a region with a very low local population, and the flux of people during the day is related to a mass of floating population.

The evaluation of comfort in public open spaces is a complex issue, since many factors interfere with pedestrian feel. Their perception includes answers to a range of stimuli to which they are exposed, not only physiological and physical, but also social and psychological. The points are located mostly close to the emblematic areas of Rio de Janeiro Centre, which have historical or cultural attributes. They also have a nice landscape around and the regions have not been shown a visual pre-disposition to discomfort. In this subject they have some similarities.

External activities in the region can be classified as predominantly ‘necessary’ (Gehl, 2001), since they do not depend on the conditions of the environment, being related to daily life. These spaces are used as binding path for the development of numerous activities, including work, school, trade, among other interrelated and providing support to the activities developed.

As mentioned earlier the determination of measuring points was to evaluate differences in spaces with urban morphology. At first the points were selected on a map, and prioritized being a point of pedestrians. Following, these points were visited and pictures of the surroundings, using the Fisheye lens, were taken. With these photos the sky view factor (SVF) and ‘solar path’ were calculated using the computational tool, Rayman-pro (Matzarakis, 2013). From the analysis of this documentation and impressions about the place visited, the seven points evaluated in this study were selected, taking into account the variations in height and proximity of buildings, existing vegetation, squares and confined spaces. The idea is to make possible the representation of the area using different configurations of urban morphology.















4 Development of the research

4.1 Defining the stop point locations

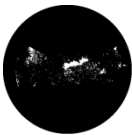
For identification around each measurement point, pictures were taken in the North, East, South and West views - identified with the use of a compass. Exhibitions geared toward heaven were also made for the determination of sky view factor (SVF). For each point, three images (bracketing) were taken to obtain an optimal point of exposure - thus allowing the subsequent selection of the most suitable for calculating the sky view factor image. Beyond the compass, a measuring tape and a spirit level were used for precise adjustment of the equipment.

From images on Table 2 is possible to observe the seven stop points determined for Rio de Janeiro city centre. The images and the SVF values allow noticing the variation in urban morphology with the representation of a greenery area, an open square, a narrow canyon etc.

Table 2: Seven stop points defined for Rio de Janeiro city centre.

Stop point	1	2	3	4	5	6	7
Fisheye image							
Black / White Image							
SVF	0.272	0.030	0.269	0.454	0.111	0.252	0.038

4.2 Campaigns and equipment

The campaigns take five hours and begin at 9 a.m. and finish at 3 p.m. As told previously, a Davis Vantage Pro2 weather station was used for measurements, as it can be seen in Figure 1. The weather station comprises an air temperature and humidity sensors at 1.1 m above ground, a three cup anemometer (at approximately 1.5 m above ground) and a silicon pyranometer at 1.4 m. In addition, as in Krüger et al (Krüger et al, 2012a-b), a globe thermometer was organized for evaluating the Mean Radiant Temperature (T_{mrt}), which consisted of a gray sphere with an enclosed temperature data logger (Tinytag:TGP-4500), attached to the tripod at 1.1 m above ground.

Data from all sensors were registered by a logger and recorded every five seconds, and averaged over one minute. T_{mrt} was calculated according to (ISO 7726, 1998) for forced convection from the measured globe temperature (T_g), wind speed (V_a), air temperature (T_a), and globe's emissivity (ϵ_g) and diameter (D) as in Krüger et al (Krüger et al, 2012a-b).

4.3 The survey

As in Krüger et al (Krüger et al, 2012a-b), a comfort questionnaire was personalised according to the recommendations of ISO 10551, 1995. The first trial had two pages and questions related to the wind, shade and other specific preferences, but it did not work because it was big enough to make people not agree to answer so many questions.

So the survey consists of items related to: gender; age; height; weight; clothing insulation adopting a look-up table with typical clothing garments (ISO 9920, 2007); time of residency in Rio de Janeiro or surroundings (to take into account the acclimatisation factor) and time spent outdoors before completing the survey. The second part of the questionnaire consisted of two symmetrical 7-point two-pole scales ranging from -3='cold' over 0='neutral' to +3='hot', used for assessing the respondent's thermal perception and preference. The time of residency and time spent outdoors were adopted as exclusion criterion of the answer, when less than 6 months and/or less than 15 minutes outdoors, respectively (Krüger et al, 2012a-b).

4.4 Temperature field simulations

The first computational simulations were done by using the ENVI-Met software, developed for climate simulations in urban areas (Bruse, 2009). This research is trying to find some answers for questions such as: how can we minimize the creation and the effects of heat islands? So, urban morphology and greenery could be helpful. An example using vegetation was done for the area close to Points 1 and 2.

The first image (Figure 3a) presents the current situation, in other words, with some greenery and the proposed change, without vegetation, is shown in Figure 3b. Even being the first tests using computational simulation, the results are able to show a qualitative response, similar to that was observed in loco. The presence of the greenery represents an increase in comfort quality.

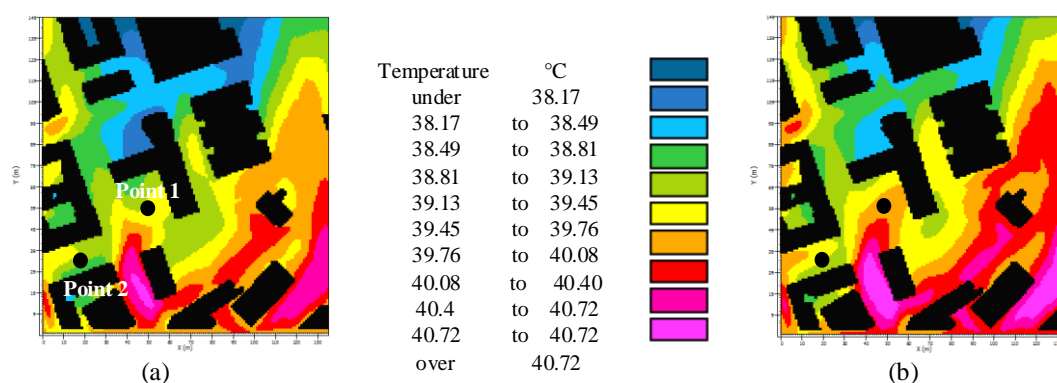

Figure 3. Area close to Points 1 and 2: (a) current scenario and (b) an imposed scenario, without vegetation.

An observer was located in a specific point (Figure 4) inside the model area, where processes in the atmosphere and the soil can be monitored in detail. It was chosen to allow comparative analysis.

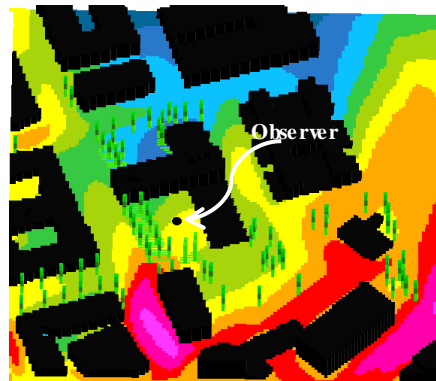

Figure 4. Observer point inside model area.

The graphical results in Figure 5 were read from the viewpoint of this observer. It is possible to notice an increase in temperature when looking the scenario without vegetation (Figure 5a) and also to observe that the difference increases in warmest time (Figure 5b).

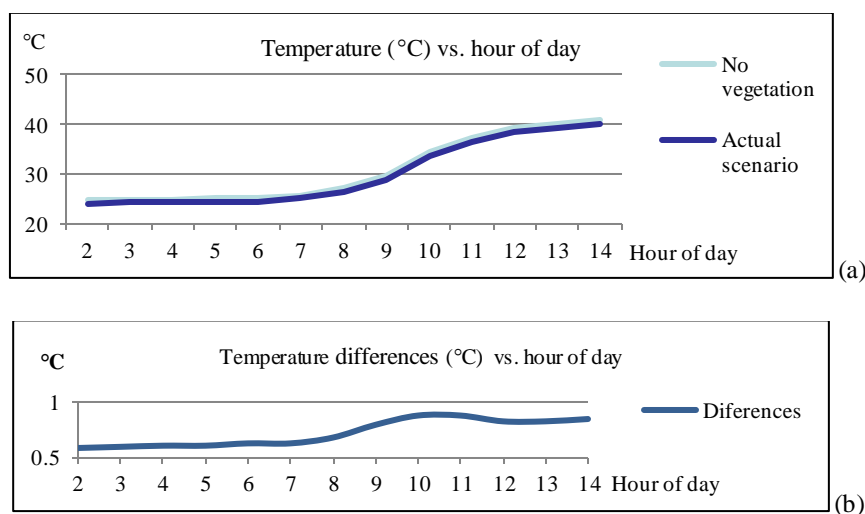

Figure 5. Graphical results: (a) both scenarios, with and without vegetation and (b) differences between temperatures during the day.

5 First Results and Discussions

The use of the 'Meteobike' does not interfere on the methodology of data collection itself. All the procedure continues to be held by the weather station sensors and processed by several computational methods. The bike only gives more speed and efficiency, in a non-polluting way, for the collection of such data. The convenience and practicality of fieldwork with the support of the 'Meteobike' was tested in several campaigns and represented a major gain since it carries the weather station (which weighs around 5.5 kg), all supporting material (questionnaires, compass, measuring tape and spirit level) and two researchers. Moreover, as previously mentioned, this allows us to leave out the heavy tripod (5.90 kg). If all these materials had to be carried by the researchers, it would mean that they would have to carry

nearly 12 kg in each measurement campaign. Apart from that, it is necessary to say that the use of this bike solves the very common problem of parking in urban centres.

On the first summer 328 surveys were according to the exclusion criterion. The first results seem to indicate, as expected, that greenery represents an important ally to improve environmental quality in open areas. Streets, as Pedro Lessa in the city centre, presented, even in warm day, better thermal sensation if compared with other areas without vegetation.

The utilization of the green areas and their cooling effect on urban climate has been explored all over the world in the last years, and indeed the UHI effect is intensified due to the lack of green areas in the urban environment (Wong & Yu, 2005). The use of greenery can be also considered as one of the most important methods to mitigate the UHI effect (Lu et al, 2012; Chen & Wong, 2006; Argiro & Marialena, 2003).

If thinking in the future, researches have pointed that the growth of vegetated areas in urban areas can represent an important way to mitigate and adapt to the negative climatic effects of climate changes expected in the near future (Shimoda, 2003; Oliveira et al, 2011).

In his book Emmanuel (Emmanuel, 2005) indicates some strategies for the tropics, among them the need to act in small spaces aiming to improve the comfort conditions in each block. He proposes the use of natural elements (vegetation and water) as tempering agents and indicates, from studies, the effectiveness of an action on micro scale, i.e., a larger number of small parks influence the microclimate of a larger area to their immediate surroundings. He argued that the major elements of the climate modifiers have little influence if not treated in micro scale.

Emmanuel (Emmanuel, 2005), Oliveira et al (Oliveira et al, 2011) state that even small green areas can contribute to the mitigation of the UHI and global warming effects on the cities, but they alert to the detail that thermal performance of a green area and its influence in the surrounding environment depend on the urban and climatic features of the city. Therefore, Oliveira et al (Oliveira et al, 2011) also admit that

6 Conclusions

Similar researches have even now been done mostly in temperate climates but further studies are needed in order to provide more and more detailed information about this subject taking into consideration the specific features of each city.

In the case of Rio de Janeiro city, which has been suffering a constant enlargement, it is important to evaluate the high-use areas, such as the city centre as it can be observed, where small alterations in the public space sometimes are able to represent substantial gains in quality of space. The intense afforestation, present at Rua Pedro Lessa, allows its users to enjoy a more pleasant environment.

There are many variables and possibilities for urban form and any proposition should consider solutions guided by beliefs or generalizations. In any project or proposal, the study of models for simulation can assist in decision making of architects and planners.

To deal with the differences related to tropical climates, plus the consequences of global warming, it is really necessary more research and persuasion to find ways to convince the community and private institutions to contribute to apply strategies, some of them really simple to put in practice, but efficient to improve life quality.

Acknowledgements

Patricia R. C. Drach thanks the support of the Conselho Nacional de Desenvolvimento Científico e Tecnológico - CNPq (National Council for Scientific and Technological Development) - Program Brazil Science without Borders – 246551/2012-7.

References

- Argiro, D.; Marialena, N. 2003. Vegetation in the urban environment: microclimate analysis and benefits. *Energ Build.* v1, pp. 69-76.
- Barbosa, G. S.; Drach, P. R. C.; Corbella, O. D., 2010a. A Comparative Study of Sprawling and Compact Areas in Hot and Cold Regions: Way to Sustainable Development of Cities In: World Renewable Energy Congress 2010 - WREC XI, *Towards a Sustainable Environment: Green Building and Renewable Energy Options*. Abu Dhabi, 2010, Abu Dhabi: Environment Agency – Abu Dhabi (EAD) and World Renewable Energy Council WREC/UK.
- Barbosa, G. S.; Drach, P. R. C.; Corbella, O. D., 2010b. Um Estudo Comparativo de Regiões Espalhadas e Compactas: Caminho para o Desenvolvimento de Cidades Sustentáveis. In: Congresso Internacional Sustentabilidade e Habitação de Interesse Social, *Anais do CHIS*. Porto Alegre, 2010, Porto Alegre: EDIPUCRS.
- Bruse, M. *ENVI-met. Version 3.1 BETA IV*. On-line Manual. In: <http://www.envi-met.com>. Latest Build: 14-Dec-09, 2009.
- Carneiro, M. S. C.; Bastos, L. D.; Castro, M. S.; Drach, P. R. C.; Corbella, O. D., 2012. Estudo experimental comparativo da ventilação na região portuária do Rio de Janeiro. In: PLURIS 2012, *Anais do Congresso Luso Brasileiro para o Planejamento Urbano, Regional, Integrado e Sustentável - PLURIS 2012*. Brasília, 2012, Brasília: UnB.
- Chen, Y.; Wong, N.H. 2006. Thermal benefits of city parks. *Energ. Build.* v38, pp. 105-120.
- Drach, P. R. C.; Corbella, O. D.; Barbosa, G. S.; Shin, D. B.; Carneiro, M. S. C.; Bastos, L. D., 2013. Ventilation and urban morphology relation: Two neighbourhoods in Rio de Janeiro city, Brazil. In: 29th Conference, Sustainable Architecture for a Renewable Future - PLEA 2013, *PLEA 2013 - Sustainable Architecture for a Renewable Future*. Munique, 2013, Munique: Technische Universität München.
- Emmanuel, M. R., 2005. *An Urban Approach to Climate-Sensitive Design. Strategies for the tropics*. New York: Spon Press.
- Gehl, J., 2001. *Life between buildings*. 4th edition. Copenhagen: Danish Architectural Press.
- Krüger, E. L.; Drach, P. R. C.; Emmanuel, R.; Corbella, O. D., 2012a. Urban heat island and differences in outdoor comfort levels in Glasgow, UK. *Theoretical and Applied Climatology*, v. 112, p. 127-141.
- ISO 10551, 1995. *Ergonomics of the thermal environment – Assessment of the influence of the thermal environment using subjective judgement scales*. Geneva.
- ISO 7726, 1998. *Ergonomics of the thermal environment – Instruments for measuring physical quantities*. Geneva.
- ISO 9920, 2007. *Ergonomics of the thermal environment – estimation of the thermal insulation and evaporativeresistance of a clothing ensemble*. Geneva.
- Krüger, E. L.; Drach, P. R. C.; Emmanuel, R.; Corbella, O. D., 2012b. Assessment of daytime outdoor comfort levels in and outside the urban area of Glasgow, UK. *International Journal of Biometeorology*, v. 57, p. 521-533.
- Krüger E. L.; Minella, F. O.; Rasia, F., 2011. Impact of urban geometry on outdoor thermal comfort and air quality from field measurements in Curitiba, Brazil. *Build Environment*, v. 46, n. 3, p. 621-634.

Lu, J.; Li, C.; Yu, C.; Jin, M.; Dong, S. 2012. Regression analysis of the relationship between urban heat Island effect and urban canopy characteristics in a mountainous city. *Chonging. Indoor and Built Environ.* v21(6), pp.821-836.

Matzarakis, A. 2013 - *Rayman Pro software*, developed by Andreas Matzarakis. Available at: <http://www.mif.uni-freiburg.de/RayMan/>, 2013.

Oliveira, S.; Andrade, H.; Vaz, T. 2011. The cooling effect of green spaces as a contribution to the mitigation of urban heat: a case study in Lisbon. *Building and Environment.* v46, pp. 2186-2194.

Shimoda, Y. 2003. Adaptation measures for climate change and the urban heat island in Japan's built environment. *Building Research and Information.* v31(3-4), pp. 222-30.

Taha, H., 1988. *Night Time Air Temperature and the Sky-View Factor: a Case Study in San Francisco, California.* Berkeley: Lawrence Berkeley Laboratory.

Wong, Hien N.; Yu, Chen. 2005. Study of green areas and urban heat island in a tropical city. *Habitat International.* v29, pp. 547-558.

Daylight quality in healthcare architecture - Developing a framework

Alaa Sarhan¹, Bakr Gomaa², Mohamed Elcharkawi³

1 Architectural Engineering and Environmental Design Department, Arab Academy for Science and Technology, Alexandria, Egypt;

2 Architectural Engineering and Environmental Design Department, Arab Academy for Science and Technology, Alexandria, Egypt, gomaa.architect@yahoo.co.uk;

3 Architectural Engineering and Environmental Design Department, Arab Academy for Science and Technology, Alexandria Egypt, mhcharkawi@hotmail.com.

Abstract

Through history; a large body of research has found a relationship between the IEQ and the recovery of patients in healthcare facilities. IEQ factors include natural ventilation, daylighting, acoustics, materials off gassing, etc... This research is to identify the guidelines to healthy daylighting in hospital buildings. Research methods include grounded theory finding through intensive literature review and analysis of successful international examples. Following comes the theory testing to assess daylight quality in a regionally acclaimed self funded "The Children Oncology Hospital" - locally known as 57357 - the study is expected to shed the light on the architectural design principles for daylighting as well as the thorough investigation of the case study building.

Keywords: Healing environment; Indoor environmental quality; Daylight quality; Energy saving; Design guidelines.

1 Introduction

One of the most famous quotes in architecture is "*Form follows function*", once said by the American architect Louis Sullivan in his article "The tall office building artistically considered", (Verderber, 2010) in his book "Innovation in hospital architecture"; wrote that "*The very first requirement of a hospital is that it shall cause neither human nor ecological harm*", a multi dimensional concept, he thought that the function of the hospital is to enhance the healing process of patients, not harming them, also it should have the role of the environmental stewardship in its urban context, promoting the concept of ecological health and human wellness, and architects should help this concept by enhancing the design of physical environment of the hospital, and so, the form of the healthcare building and its indoor built environment follows its intended function. There are a number of scientific evidence proving that a poor design works against the wellness of patients and gives negative psychological indicators (Marberry, 1995), and in the 1990s there were some innovations in the design of the hospital's built environment based on some of these "Evidence based medicine" published research, and these solutions were defined as "Evidence based design" EBD. (Huisman, 2012).

"An optimal healing environment is one where the social, psychological, physical, spiritual, and behavioral components of healthcare support and stimulate the body's innate capacity to heal itself" (Ananth, 2011). In the "Journal of science and healing" since August 2008, Sita Ananth began to discuss and develop what she called "Optimal healing environment" OHE, she set a number of settings to create it: Internal, interpersonal, behavioural and external, this paper is considered with the factors of the "external criteria"; which is divided into two

topics: building healing spaces and ecological sustainability. The building healing space factors are four sensory; colour and light, aroma and air, music and sound, and art.

(Ulrich and Zimmiring, 2004) investigate the role of the physical environment in the hospital by over viewing a large number of “evidence based medicine” research, and they concluded that seven points contribute to IEQ including constrains on noise level, access to daylight, and ventilation improvement. Also in 2010, Stephen Verderber in his book “Innovation in hospitals architecture” stated that there are six patterns or healing agents that links built environment to human health, and sustainability; two of which are natural ventilation and natural daylight.

This paper is concerned only with the objective of design criteria for optimal daylight quality as an important contributor to an important aim of better human health and experience in the healthcare facility.

2 Built environment and human health check points in history

The importance of this study is evident through the history of healthcare architecture; it is one of the criteria of creating or restoring the relationship between human health and the built environment (H.H and BE); in ancient Greece, after the Hellenistic period, they believed in the presence of gods skilled in the art of healing, and they formed a number a healing cults for each god, the most famous cult was that of Asclepius son of Apollo. The Asclepieions, the name of the temples referring to the cult of Asclepius, were considered the hospitals of this ancient era, the strategy of positive distraction and supportive design was present using the performing arts that had good effects on patients (Kjisik, 2009). The natural environment was considered an important aspect of the care strategy, the interaction with nature, vegetation and patients’ exposure to sunlight became with high priority (Verderber, 2010). The patient care setting in the Asclepieion of Epidauras in Athens was in stoa form where the patients’ beds lays in the entire length of the hall, so they could experience natural ventilation and daylight through the portico, the hall had three enclosed sides and the fourth opened side through the row of columns was exposed to the south allowing the maximum amount of daylight to penetrate into the interior, and to allow visual interaction to the outside natural environment (Verderber, 2010). Later in the Greek era, it was the rise of curative strategies based on rational medicine (Longrigg, 1998). Hippocrates, father of medicine, was the first to define medicine as an individual rational science apart from philosophy, he believed that the site orientation strategy for cities and the environmental factors had an impact on human health (Chadwick, Mann, 1983).

In Europe, during the middle ages, the dominating beliefs were again that illness is caused by super natural forces and it can only be cured by religious actions (Kjisik, 2009), “*with the decline of secular city-states the catholic church emerged to fill the void in healthcare across Europe*” (Verderber, 2010). During this era, as the Christian religious orders are in charge, the belief in nature and landscape as aspects of treatment diminished and the treatment process was held in a network of cross-ward monastic hospitals where natural daylight and ventilation were of minimal importance (Verderber, 2010).

In the Muslim near east the conditions was totally different. “*Yet the Middle Eastern hospital was one of the most developed institutions of medieval Islam, and represented, both architecturally and medically*” (Montague, 1984). There are different examples for the hospitals in this Islamic era, Nuri hospital and Argham hospital in Syria, Ibn Tulun hospital and Mansuri hospital in Egypt, Kulliyesi hospital in turkey. Montague states that in the this era in the middle east, the medical institution was the beacon for all the upcoming eras of

healthcare, as for the architectural concern, according to Monague's descriptions, there was a high regard for the IEQ of the hospitals; day lighting quality, shading and ventilation offered by the shape and orientation of the hospital's mass' and the thermal comfort which was demonstrated with the difference between two courtyards one in hot climate of Baghdad with no ceiling and one in the cold climate of Anatolia covered with a vaulted masonry ceiling. It was also demonstrated through the use of water streams freely falling -that has an echo in the Arab mentality- to offer security and comfort that there was a high regard for the concept of the supportive design to reduce the patients' stress.

"Florence Nightingale, the founder of the modern nursing, who was an outspoken advocate for the use of the environment for therapeutic purpose." (Marberry, 1995). Florence Nightingale, began a healthcare architectural trend that dominated a period of 85 years since 1860 to the world war two 1945, after she was back from the war in turkey in 1855 to reform soldiers' barracks hospital she was praised for her remarkable achievements, then she wrote two influential books; notes on nursing in 1858 and notes on hospitals in 1895. In these books she assured the importance of what we call now the indoor environmental quality in the patients' wards (Verderber, 2010). *"She stated five essential point in securing a sustainable, health promoting environment: pure air, pure water, efficient drainage, cleanness and natural daylight"* (Verderber, 2010). In her book notes on hospitals she stated in the introduction a number of defects causing hospitals to offer disease more than being a curative environment, in between these defects there was two of them related to the environmental quality: deficiency of ventilation and deficiency of light, she offered states and discussions about how these two factors affect the recovery of the patients physically or by supporting those morally (Nightingale, 1863). In another chapter of her book, (principles of hospital construction), she offered criteria of 18 points leading to her functional and environmental vision for a hospital, there was a number of points about ventilation and day lighting of wards, and even the points stating a functional requirements were reasoned with an environmental purpose concerning lighting and ventilation quality (Nightingale, 1863). *"Florence Nightingale main functional objection to what she had seen was lack of direct visual supervision of patients, while her clinical objections centered on the lack of fresh air and daylight."* (Kjisk, 2009).

In eras mentioned before there were no scientific proofs on the impact of the built environment on the human health and healing process. As later in the 1980s evidence based medicine research will begin. (Guenther and Vittori, 2008).

3 Evidence based medicine and supportive design strategy

When comes in mind the design of healthcare facilities, architects always think about fulfilling the functional requirements, such as providing efficient space for operation rooms and wards or the width of doors to allow stretchers movement, *"This emphasis has often produced facilities that are functionally effective but psychologically hard"* (Ulrich, 1991). *"People in the hospital world may claim the physical side can be dealt with successfully by simply adhering to healing environment principles"* (Kjisk, 2009), the healing environment is a concept that lately investigated with a number of evidence-based researches, proving that the physical environment of the healthcare facility affects the healing process (Kjisk, 2009). *"By the 1980s, a body of research emerged indicating that a connection to nature positively influences medical outcomes and staff performance"* (Guenther and Vittori, 2008). Until 2012; 65 scientific article emerged that fit a criteria Huisman has put in his review to fulfil the concept of the Evidence Based medicine. (Huisman, 2012).

In 1984, Roger Ulrich published one of the first and most famous scientific papers about how the built environment has an impact on recovery “View Through a Window May Influence Recovery From Surgery”; in which an experiment was conducted; all physical characteristics of two rooms were made identical, except for one of the rooms had brick wall, while the other had a window to overlook a small stand of trees. Two different patients who have identical status were asked to stay into the rooms for a certain period of time; it was found that the patients in rooms with window to the view had shorter postoperative hospital stay rather than those who overlooked a brick building wall (Ulrich, 1984). Also, Roger Ulrich stated from another study that visual exposure to everyday nature has produce “significant recovery from stress within only five minutes or less, as indicated by positive changes in physiological measures such as blood pressure and muscle tension” (Marberry, 1995), the findings are presented in (Fig.1).

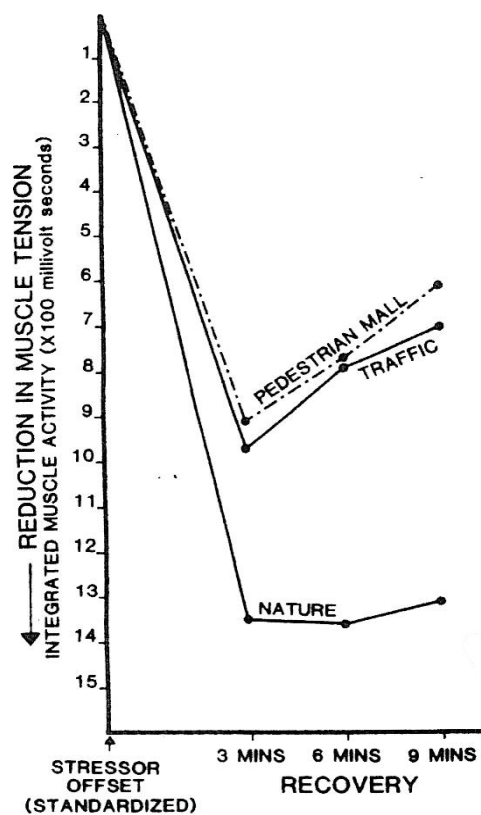

Figure 1 Ulrich's experiment findings (Marberry,

Architectural design should do more than produce health facilities that are efficient only in term of functional requirements, design should create physical environment that is “psychologically supportive” (Ruga, 1989), “the effect of this supportive design are complementary to the healing effects of drugs and other medical technology and foster the process recovery” (Marberry, 1995). The supportive design strategy is important to help patient deal with the stress parallel to his illness (Ulrich, 1991). “The effects of supportive design are complementary to the healing effects of drugs and other medical technology, and foster the process of recovery. By comparison, hard settings raise obstacles to coping with stress, contain features that are in themselves stressors, and accordingly ass to the total burden of illness.” (Ulrich, 1991). The stress can be manifested psychologically by the sense of depression and helplessness, but to understand more its impact on the recovery process;

the physiological impact must be manifested: *“Physiologically, stress involves changes in bodily systems, such as increased blood pressure, higher muscle tension, and high level of circulating stress hormones. A considerable body of research has shown that stress response can have suppressive effects on immune system functioning. Reduced immune functioning can increase susceptibility to disease and work against recovery.”* (Marberry, 1995).

4 The impact of daylight quality on healing and recovery process

Daylight as a single factor within the settings of the healing environment and the supportive design has its own specified scientifically proved impact on the healing process. After a successful treatment for patients with seasonal affective disorder and Alzheimer disease with exposure to artificial high-intensity light (bright light therapy), a belief has grown that the exposure to natural daylight may also influence health outcomes (Van den Berg, 2005). Marberry in her book *“Improving Healthcare with Better Building Design”* states after a number of studies that *“higher level of light exposure, compared to lower levels, are effective in reducing depression”* (Marberry, 2005), she stated also that (Lewy et al., 1998) proved that the morning light is twice effective than the afternoon light in improving patients’ conditions.

Choi, Beltran and Kim in 2011 made a study on the impacts of indoor daylight environment on patients “average length of stay” ALOS in a general hospital in Incheon in Korea, they concluded that although the several critical factors that affects patients recovery which makes it difficult to identify a single role for the daylight in the healing process, that *“A significant relationship appears to exist between indoor daylight environment and patients length of stay (ALOS).”* (Choi, Beltran, Kim, 2011).

“A recent prospective study of pain medication use among 89 patients undergoing spinal surgery showed that patients staying on the bright side of the hospital (with an average higher intensity sunlight) experienced less perceived stress, marginally less pain, and took 22% less analgesic medication per hour than patients on the dim side of the hospital” (Van den Berg, 2005) after Walch et al. study in 2005.

5 Generating criteria from daylight science

5.1 Daylight and Sunlight

The “daylight” differs from the “sunlight”, as according to (IESNA, 2000) the daylight is where the sky acts as a light source. (CIBSE LG10, 1999) expressed that the skylight is *“light which has been scattered by molecules of air, aerosols and particles such as water droplets in clouds in the atmosphere; excludes direct beam”*, and the sunlight is *“the visible direct beam solar radiation”*.

Although the scope of this research is the daylight calculation methods and metrics; in hot arid zones where clear sky is dominant all over the year, sunlight, sun movement and directions must be taken in consideration to avoid discomfort from heat gain and glare (Kensek, Suk, 2011).

5.2 Daylight source

“As sunlight passes through the atmosphere, a portion is scattered by dust, water vapor, and other suspended particles. This scattering, acting with clouds, produces sky luminance.” (IESNA, 2000).

“The (no-sky line) gives an indication of the area beyond which daylight may not contribute to general room lighting” (CIBSE, 2002).

The sky dome is the source of daylight, and skies are divided into three categories: Clear sky; Overcast sky; and Intermediate sky (partly cloudy in other references) (Muneer, 1997). These three categories are standard and developed by the Commission Internationale d'Eclairage CIE (International commission on illuminance); a worldwide commission concerned with the matters of lighting (CIBSE LG10, 1999).

5.2.1 Clear sky

The clear sky is where the cloud cover is less than 30% (IESNA, 2000) or no clouds at all, *"The sky is brighter towards the location of the sun, and the sun is visible."* (Kensek, Suk, 2011). This model must be used in predominant sunny climate area as it is useful when visual glare and thermal discomfort studies are made which is out of the research scope. *"Incoming sunlight can give warmth and brightness but it can also cause glare and thermal discomfort"*. (The desktop guide to daylighting, 1998).

5.2.3 Overcast sky

It is the sky 100% covered with clouds, and mainly adapted and used in simulation programs to calculate the worst case scenario for daylight quality (Kensek, Suk, 2011). *"An overcast sky acts as a relatively bright, diffuse light source. This diffuse light is ideal for daylighting design. Since it is not as bright as direct sunlight, diffuse light is an easier source control."* (Daylighting guide for Canadian buildings, 2002).

5.2.4 Intermediate sky

It is when the sky is not completely overcast. As the sun is alternately sometimes revealed and other times obscured during the day; the luminance of the sky dome varies and change rapidly by large amount (IESNA, 2000).

5.3 Daylight factor DF

"The daylight factor is the percentage for daylight available inside the room, relative to daylight available outside the room measured on an overcast day." (Kristensen, 2010). It is the Illuminance received at a point in the indoor expressed as a percentage to the diffuse illuminance outdoors on a horizontal plane under an overcast sky (CIBSE LG10, 1999). according to the (Daylighting rule of thumb, 2009) and is defined by the upcoming equation:

$$DF = [E_{in} / E_{ext}] \times 100 \quad (1)$$

Where; DF is the daylight factor in percent, E_{in} is Interior illuminance at a fixed point on the work plane, and E_{ext} is exterior illuminance under an overcast sky.

5.4 Average Daylight Factor ADF

The difference between the Daylight factor DF and the Average daylight factor ADF is that the former is the value at a specified point on a work plan as stated previously, while the latter is the average of a number of values at a number of points on a work plane (IESNA, 2000). The ADF is identified by the (CIBSE LG10, 1999) as *"The average indoor illuminance on a reference plane or planes (Usually the working plane) as a percentage of the simultaneous outdoor illuminance from the unobstructed sky."*

The Average Daylight factor ADF according to the (CIBSE Code for lighting, 2002) is presented mathematically using the equation (2):

$$ADF = [A_g \times \theta \times \tau] / [A \times (1-R)] \quad (2)$$

Where; ADF is average daylight factor in percent, τ is the decimal transmittance of the glazing, A_g the net glazing area, A is the total interior surface area including windows, R is the area average reflectance of all interior room surfaces including windows, and θ is the angle in degrees in the vertical plane of visible sky from the centre of the window.

Same reference as all codes and guidelines mentioned before in this section specified values of Average daylight factor and its influence on a daylight appearance in a room. (Table 1)

Table 1: Average daylight factors and daylight quality in space

Average daylight factor	Daylight quality in space
5% or more	The space has a bright daylight, daytime electric lighting is unnecessary, but heat control is needed.
2-5%	The space has a predominantly daylight appearance, but electric lighting is needed in rooms background.
Below 2%	Electric lighting is necessary and dominant, windows gives only exterior view.

5.5 Useful daylight illuminance UDI

The useful daylight illuminance UDI is a new scheme developed in 2005; used to assess the daylight quality in a room as a replacement for the ADF scheme. UDI are defined as the value of illuminance in between 100 Lux to 2000 Lux. This range is based on the review of updated data from field studies concerned with human behavior under daylight conditions (Nabil and Mardaljevic, 2006). The UDI index is as follow in (table 2) findings are quoted from (Nabil and Mardaljevic, 2006):

Table 2 Useful daylight Illuminances UDI index

Illuminances	Scheme	Findings
Less than 100 Lux	Fall short of the useful range	<i>"Generally considered insufficient either to be the sole source of illumination or to contribute significantly to artificial lighting."</i>
From 100 to 500 Lux	Useful range	<i>"Considered effective either as the sole source of illumination or in conjunction with artificial lighting."</i>
From 500 to 2000 Lux		<i>"Are Often perceived either as desirable or at least tolerable."</i>
Higher than 2000 Lux	Exceed the useful range	<i>"Are likely to produce visual or thermal discomfort, or both."</i>

5.6 ADF and UDI use in the research

As stated previously, the values of the ADF are to predict the daylight quality under overcast sky, and as the UDI is based on the variable amount of light all over the year (Nabil and Mardaljevic, 2006); the UDI would be more suitable for a dominant clear sky as in Egypt. So in the Case study the Illuminance values will be compared to the UDI Index to judge the daylight quality in spaces.

The purpose of introducing the ADF method in this research is that after the review of a number of published research and papers including the publications of the CIBSE and the IESNA concerning daylight design; the component of the equation (2) to calculate the ADF presents the architectural factors that affects the daylight quality in a room. The equation (2)

will be used to generate the design criteria for daylighting; by transforming its components into categories presenting the factors of the built environment
Equation 2 comprises four different factors; and Each of the factors is impacted by a number of sub-factors as indicated in (Table 3).

Table 3: Factors and sub-factors of equation (2)

Orientation and surrounding context			Means of daylight penetration		Space geometry		Finishing materials	
Orientation	Shading strategy	Visible sky and obstruction level	Main opening technology	Glazing type	Glazing area	Room depth	Color of surfaces	Reflectance of surfaces
θ			T		Ag and A		R	

6 Theories and previous research

The next section assesses through theory overview and other researches' findings the best and preferred specifications for each category to refine the criteria to be specified healthcare facilities.

6.1 Orientation and surrounding context

6.1.1 Visible sky and obstruction level:

"If the sky is not directly visible from a point in an interior, the level of daylight at that point will be small." (CIBSE Code for lighting, 2002). The sky visible from a window is constrained by the surrounding context, and so, the site choice is a major decision regarding the daylight quality in subject building (Daylight in buildings, 2000). If the window will be used as a main source of light; the surrounding obstruction facing it should not be higher than 25 degree above the horizon (The desktop guide to daylighting, 1998). The vertical angle of sky is measured from the center of window, it varies between 0 and 90 degree. The vertical angle is 90 if no obstruction is present (O'connor).

6.1.2 Orientation:

Each orientation in the four orientations can provide daylight but each orientation must be treated adequately for best results. The (table4) is the visualization for the impact and handling of each orientation by (O'connor):

Table 4: orientations and impact on daylight quality

Orientation	Daylight quality	Heat gain and loss	Shading
North	high quality consistent daylight	minimal heat gains, but thermal loss during heating conditions	possibly needed only for early morning and late afternoon
South	Good access to strong illumination (the original source), although varies through the day	High heat gain special during winter as sun is in lower position than summer	Shading is easy; horizontal shading
East	Annoying Sun during early morning	High heat gain; especially in early morning and late afternoon	Shading is difficult and critical for comfort
West	Annoying sun during late afternoon		

As a conclusion; (O’connor) states that *“Windows facing generally north and south create the fewest problems.”*

The research made by (Choi, Beltran and Kim, 2011) indicated that ALOS in rooms located in South East was shorter than that in the North west area. Marberry also stated after a study by (Beuchemin and Hays, 2005) that patients having higher daylight and sun exposure show better medical outcomes than those who are in rooms facing the shaded north (Marberry, 2005). Thus the range of the south orientations is preferred for inpatient rooms.

6.1.3 Shading strategy

The sun path and movement mustn’t be neglected, as it may cause visual and thermal discomfort due to solar gain as stated before. Decisions on shading devices especially the fixed ones should be made carefully to avoid reducing daylight which could lead using electric light (CIBSE LG10, 1999); as it could lead to more obstruct the visible sky form window and so the angle of visible sky can be reduced. After (CIBSE LG10, 1999) and (O’connor); shading strategies can be divided into a) Exterior devices; b) interior devices, in (table 5) some common devices same references mentioned and described:

Table 5 strategies of shading

	Strategy	Favorable orientation	Impact on light diffused to interior	View to exterior
Exterior	Solid horizontal projection	South	More projection may obstructed viewed sky	No restriction
	Solid horizontal projections distributed vertically	South	Less projection from building; more viewed sky	Restrict view
	Canopy of horizontal louvers	South	More diffused light than previous strategies as less sky obstructed	No restriction
	Fixed vertical Louvers facing of the building	East and west	depending and the angle and position of louvers	Can restrict view depending and the angle and position of louvers
	Mesh form copper wire facing of the building	Deals with high or low angle sun	Reduce permanently diffused skylight	Permits filtered view
	External projecting awnings	South	Choice of material from near opaque to translucent affects the diffused light	No restriction
Interior	Retractable Venetian blind with fully control on slats angle	Good shielding against sun beam	Obstruct sky when fully drawn	Depends on the angle of slats
	Fabric roller blind	Wide range to restrict penetrating sun beam	Obstruct sky when fully drawn	Obstruct view when fully drawn

“An efficient shading device that can remove lighting stressors, while still maintaining a proper level of illuminance is critical to a patient’s comfort and increases his/her level of satisfaction” (Choi, Beltran and Kim, 2011). This statement is fitting to one of the settings of the supportive design strategy to cope with stress developed by Ulrich, which is “sense of control” (Ulrich, 1991). So, operable blinds and curtains are important for the patient to control his environment.

6.2 Means of daylight penetration

6.2.1 Main opening technology

There are various technologies to let penetrate directly the daylight into the building, and each technology has a number of application. The most important technologies can be distributed into two categories: a) Side lighting; b) Roof lighting; and c) Supporting techniques. These three categories are inspired and set after the combination between the writings of (CIBSE LG10, 1999); (IESNA, 2000); (Kristensen, 2010); and (Daylight in buildings, 2000) and for further description of application these references can be reviewed.

From the concept of “supportive design” access to nature is required (Ulrich, 1991). And for this, side openings can be used to have views on nature, and this cannot be done through roof openings. The experiment made by Ulrich proving the effect of views from patients’ rooms on the recovery process was explained in a previous section.

6.2.2 Glazing type

Form the glazing transmittance calculator, there are two types of glazing, single or double and each layer can be tinted green, blue, bronze or grey, and layers can be filled in between with argon gas, and each type has a different transmittance. There is no mentioning for a specified type preferred for healthcare facilities serving the concept of healing environment, the choice will depend on the region and orientation of the building to cope with the heat transfer, as for sure form a best daylighting point of view, a higher transmittance type is preferred.

6.3 Space geometry

Concerning glazing area, according to the (Desktop guide for daylighting, 1998); a room can have a day-lit appearance if the area of glazing is at least 1/25 (or 0.04) of the total room area, and there are no specified specification for an inpatient room. Also (Daylighting rule of thumb, 2009), identifies that the room limiting depth is decided by two factors Window head height WHH and the presence of horizontal shading device. (Table 6)

Table 6: Impact on horizontal shading on rooms' depth

Horizontal shading device present	depth less than (2 * Window head height)
No horizontal shading device	depth less than (2.5 * window heat height)

6.4 Finishing materials

No intensive information could be found regarding the adequate colors in healthcare facilities to serve the concept of healing environment. Although form daylight quality perspective; bright colors have higher reflectance than dark colors.

Indoor environmental quality design criteria is more interest in the materials choice in which the priority is given to anti-bacterial materials. Comes second; high reflectance materials which are beneficial to increase the daylight quality. There is a growing body of research proving that hard and glossy materials such as vinyl have more advantages for patients than other flooring material like carpets, and this fact is by regard to infection rates and bacteria growing in mediums like carpets textiles (Ulrich, 2004), and so, also on the other side concerned with daylight quality; a glossy material has higher reflectance than carpet’s textile.

7 Daylight criteria for healthcare architecture

Table 7 sums up the findings from all the previous sections and offering a final checklist for the adequate daylight criteria for inpatient rooms in hospitals. The highlighted grey factors are the best specification for the daylight quality in an inpatient room.

Table 7: Daylighting design criteria checklist

Orientation and surrounding context	Window Orientation	North				
		South				
		East				
		West				
		North east				
		North west				
		South east				
		South west				
	Shading device	None				
		Exterior	Horizontal			
Vertical						
Mesh						
Interior		Venetian blind				
	Fabric roller blind					
Angle of obstruction from the horizon	25 degree		Above			
			Under			
Means of daylight penetration	Main opening technology	Side opening				
		Roof opening				
	Glazing type	Single glazing	Clear float (0.82)			
			Tinted green (0.66)			
			Tinted bronze (0.46)			
			Tinted blue (0.50)			
			Tinted grey (0.39)			
		Double glazing	Clear float + clear float (0.70)			
			Clear float + low E glass (0.69)			
			Low E glass + Low E glass (0.65)			
			Clear float + Low E glass + Argon (0.69)			
			Low E glass + low E glass + Argon (0.65)			
	Space geometry	Glazing to room area ratio	1/25		Above	
					Under	
Room limiting depth		Horizontal shading device available	2 * Window head height		Above	
					Under	
		No Horizontal shading device	2.5 * window head height		Above	
					Under	
Finishing Materials	colors	Dominant bright and light colors		Yes		
				No		
	Materials	Dominant glossy materials		Yes		
				No		

8 Case study – Children Cancer Hospital (CCH) 57357

A hospital belonging to the nongovernmental organisation of 57357, situated in Al-Sayeda Zaynab in Cairo, Egypt. The idea of the inauguration of the hospital was because of the high level of cancer infection between children all over Egypt. The impatient tower is in a form of three circles attached into a central node. A Copper screen filtering the view is projecting in some parts in front of the tower. (fig. 2).



Figure 2 Children Cancer Hospital

8.1 Case study methodology

To investigate orientation impact; two rooms with different directions without screen were chosen; R1 South West and R3 East. And to investigate the screen impact; two rooms with same orientation were chosen, one with screen (R2) and the other without (R1).

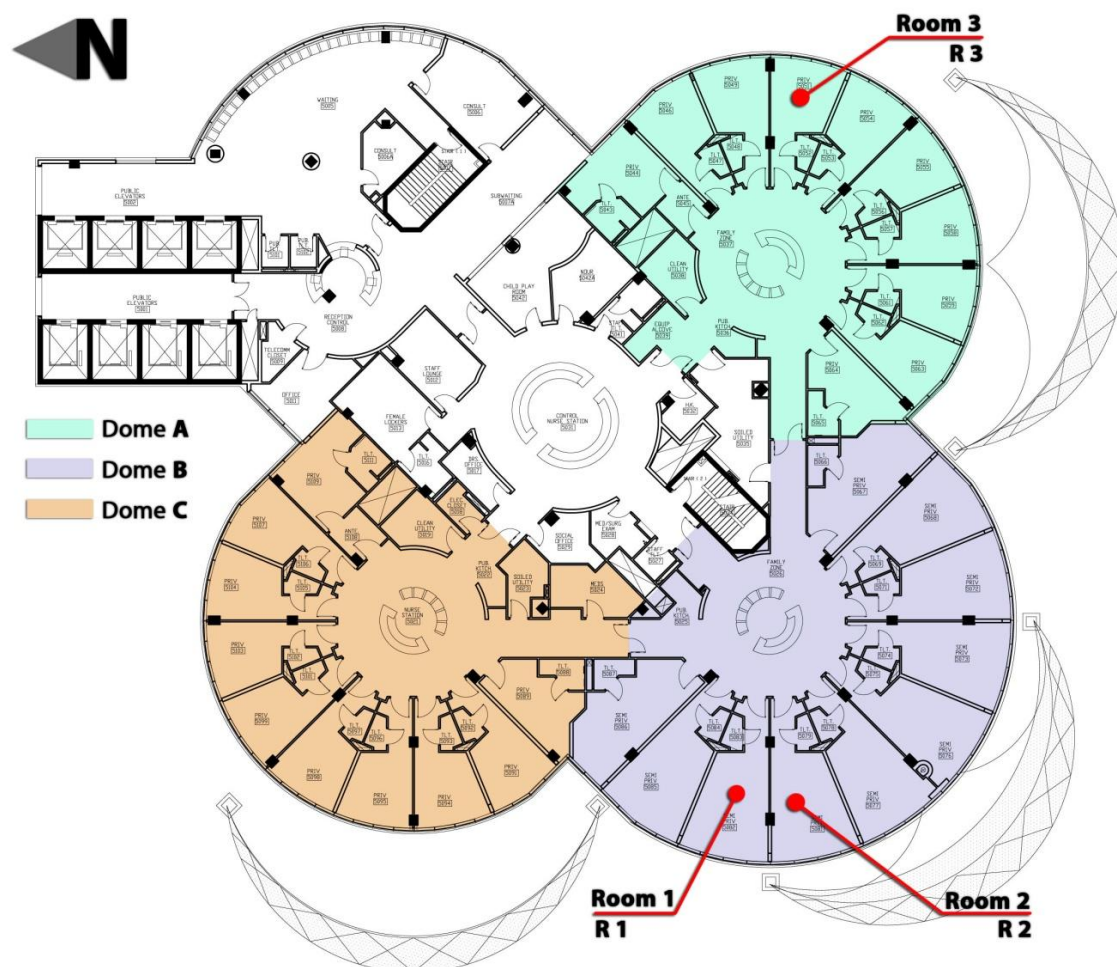

Figure 2 Children Cancer Hospital (57357 Cancer hospital engineering department)

8.2 Assessing rooms to criteria

Assessing the 3 rooms to the criteria checklist developed in the previous section (Table 8).

Table 8: Assessment of daylight design performance criteria

					R1	R2	R3	
Orientation and surrounding context	Window Orientation	North						
		South						
		East				•		
		West		•	•			
		North east						
		North west						
		South east						
		South west						
	Shading device	None		•		•		
		Exterior	Horizontal					
			Vertical					
			Mesh			•		
		Interior	Venetian blind					
Fabric roller blind			•	•	•			
Angle of obstruction from the horizon	25 degree	Above		•	•	•		
		Under						
Means of daylight penetration	Main opening technology	Side opening			•	•	•	
		Roof opening						
	Glazing type	Single glazing	Clear float (0.82)					
			Tinted green (0.66)					
			Tinted bronze (0.46)					
			Tinted blue (0.50)					
			Tinted grey (0.39)					
		Double glazing	Clear float + clear float (0.70)					
			Clear float + low E glass (0.69)					
			Low E glass + Low E glass (0.65)					
			Clear float + Low E glass + Argon (0.69)					
			Low E glass + low E glass + Argon (0.65)		•	•	•	
	Space geometry	Glazing to room area ratio	1/25	Above		•	•	•
Under								
Room limiting depth		Horizontal shading device available	2 * Window head height	Above				
				Under				
		No Horizontal shading device	2.5 * window head height	Above		•	•	•
				Under				
Finishing Materials	colors	Dominant bright and light colors		Yes	•	•	•	
				No				
	Materials	Dominant glossy materials		Yes	•	•	•	
				No				

8.3 Measuring illuminance

The Illuminance measurements were taken using a (V&A) LUX meter model (MMS6610). Measurements were taken in a clear sky condition. The measurements in each room were taken in different times as in (table 9); in order to exclude the sun beam from measurement in respect to the orientation of each room and the sun path.

Table 9: times of taken measurements in rooms

Room	Orientation	Time of measurement	Shading screen
R1	South west	9:00	With screen
R2	South west	9:00	No screen
R3	East	14:30	No screen

The rooms are identical in shape and dimensions, so three contours (A; B; and C) were drawn in different depths; each contour consist of 3 points, an additional point (Ent.) was set at the narrow entrance corridor. At each point a measurement was taken. As also a measurement was taken in the exterior in front of the windows (Out.) to measure the illuminance outside (fig 3).

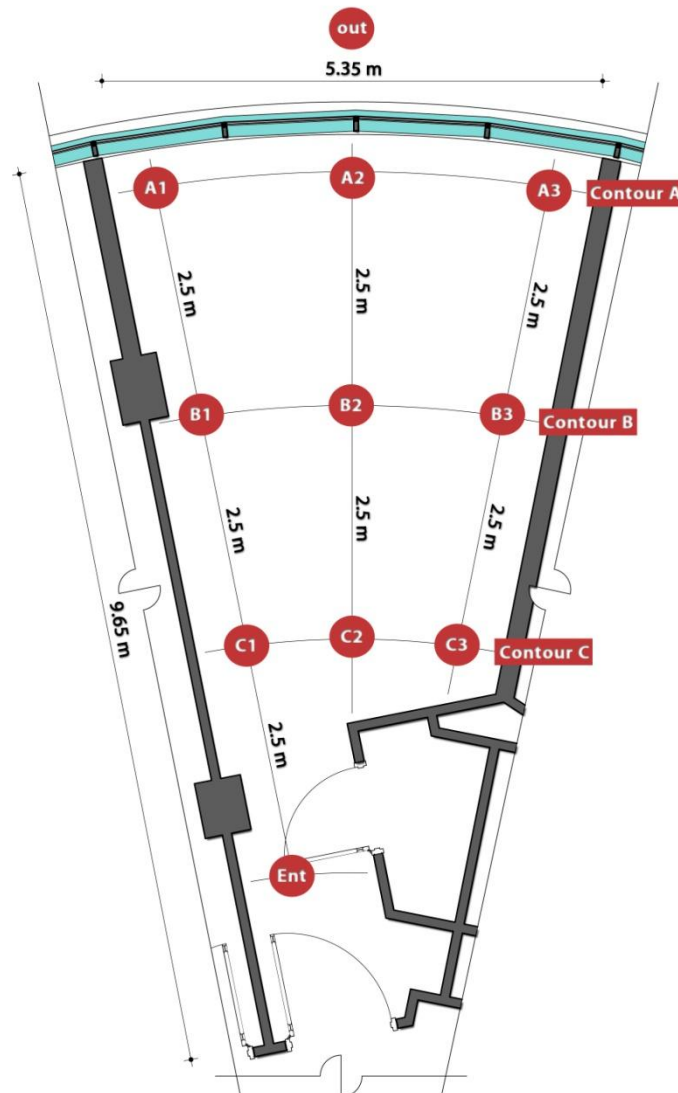

Figure 3 Contours of measurements

Measurements in the three rooms are presented in (table 10) as also the average (Av.) of the three points of each contour.

Table 10: Results of measurements in room

Room	Out.	Contour A				Contour B				Contour C				Ent.
		A1	A2	A3	Av.A	B1	B2	B3	Av.B	C1	C2	C3	Av.C	
R1	11000	1900	2000	1900	1966	700	700	700	700	350	360	350	350	60
R2	7000	1160	1200	1170	1175	180	160	175	171	60	60	60	60	10
R3	10500	1900	1950	1900	1916	600	650	600	615	300	300	300	300	60

9 Discussion

When analyzing the results of the criteria; the three rooms fulfilled the criteria in the majority of factors, as they did not fit in some. The three rooms exceeded the limiting depth; $2.7 \times 2 = 5.4$ meters, and the rooms depths are 9.65 meters. R2 was the only room with a shading device installed in front; a cooper mesh that as mentioned before decrease the diffuse light permanently. R1 and R2 had a south west orientation fulfilling the criteria as R3 did not by having an east orientation.

When analyzing the measurements results; R2 had lower value at point (Out.) than the approximately similar values of R1 and R3. And by comparing the factors of the identical rooms in direction R1 and R2; the cooper mesh in front of R2 is the only difference, and it is believed it is the reason of the low value of point (Out.); as the cooper mesh decrease the diffused light before it reach the window. And as additional result; the values of illuminance in R2 are lower than the close values of R1 and R3, the average of every contour in three rooms is presented in Fig. (4).

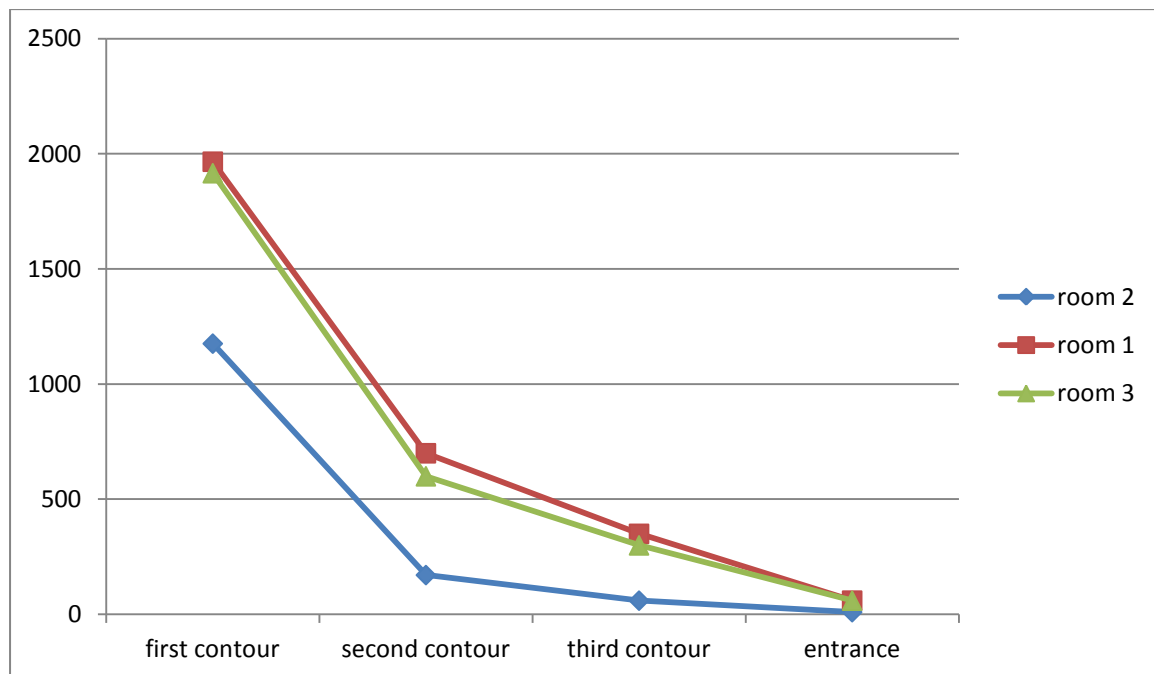

Figure 4 Average of contours in rooms

In fig. (5); illuminance values of points of each contour are compared to the UDI index mentioned before in previous section. Contour A containing point (A1, A2, A3) in the three rooms was in the “useful range”, and as being between 500 Lux to 2000 Lux range so they

are “acceptable” for the users. Contour B containing (B1, B2, B3) in the R1 and R3 are also in the “useful range” above 500, as in the R2 the contour B is also in the “useful range” but under 500 Lux so they are “considered effective as the sole source of daylight”. Contour C containing (C1, C2, C3) in R1 and R3 are in “useful range” but under 500 Lux, as in R2 it was in the “fall short” range (under 100 Lux) and considered “insufficient to be the sole source of daylight”. The point (Ent.) in the three rooms is in the “fall short” range.

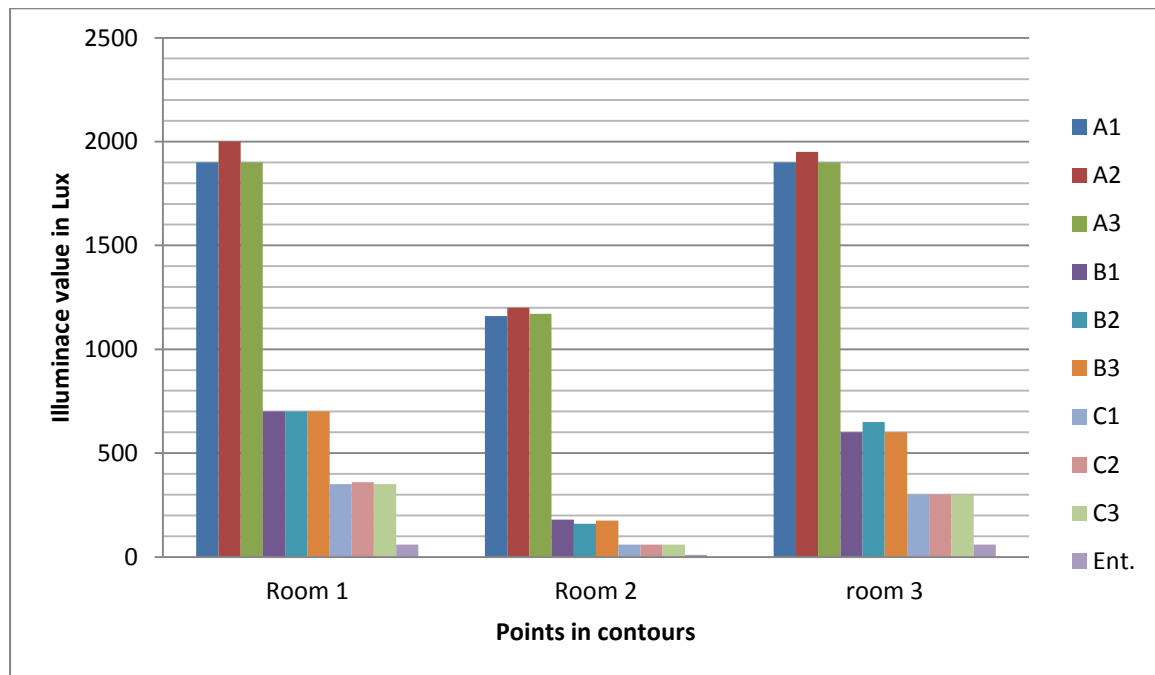

Figure 5 Points of contours compared to UDI index

10 Conclusion

The Cooper mesh in front of R2 affected the Illuminance values if compared to R1; both are identical in factors as shown in the criteria table and measurements were taken at the same time. Further future research may find a coefficient for the presence of cooper mesh affecting daylight quality. When excluding the sun beam; the rooms R1 and R3 had approximately identical values even the different orientation, and as conclusion the diffuse skylight does not depend on the orientation factor, but the sun movement and presence will give more variable and higher values of illuminance.

The depth of the three rooms exceeding the limiting depth affected the illuminance values at the entrance corridor of the rooms. But the Illuminance values compared to the UDI index in R1 and R3 were in the useful range, as also in R2, except Contour C as believed due to the mesh.

It is believed that the presence of the mesh in R2 will control the solar heat and visual discomfort when the sun is available as also in the illuminance values will be higher than the measured in this research. As also, the Values in R1 and R3 will exceed the useful range at contour A when the sun is available especially with the absence of any shading strategy.

Acknowledgments

The Egypt’s children cancer hospital (57357) for it great moral, spiritual as well as medical efforts with children struggling with devastating illness. All appreciation and thanks to the hospital’s research and engineering department for their outstanding support.

References

- Ananth, S., 2011, *Hospitals creating optimal healing environments*, Samueli Institute.
- Azza, Mardaljevic, 2006, Useful daylight illuminances: A replacement for daylight factors. *Energy and Building*, 38, pp 905-913.
- Chadwick, M., 1984, *Hippocratic writings*. London: Penguin group.
- Choi, Beltran, Kim, 2011, Impacts of indoor daylight environments on patient average length of stay (ALOS) in a healthcare facility. *Building and environment*, 50, pp 65-75.
- CIBSE, 2002, *Code for lighting*. Oxford: Butterworth-Heinemann.
- CIBSE, 1999, *Daylighting and window design, Lighting Guide LG: 1999*. Drochester: The Fairy Press.
- Daylighting guide for Canadian buildings, 2002, public works and government services, Canada.
- Daylight in buildings: A source book on daylighting systems and components, 2000, Berkeley: Lawrence Berkeley National Laboratory.
- Huisman, Morales, Kort, 2012, Healing environment: a review of the impact of physical environmental factors on users, *Build and environment*, 58, pp 70-80.
- IESNA, 2000, *The IESNA Lighting handbook: ninth edition*. New York: IESNA Publications Department.
- Kjisik, H., 2009, *The power of architecture towards better hospital buildings*. PhD. Helsinki university of technology.
- Kristensen, P., 2010, Daylighting technologies in non-domestic buildings. *Intrnational journal of solar energy*, 15: 1-4, pp 55-67.
- Longrigg, J., 1998, *Greek medicine from the heroic to the Hellenistic age*. New York: Routledge.
- Marberry, S., 1995, *Innovation in healthcare design*. New York: Van Nostrand Reinhold.
- Marberry, S., 2005, *Improving healthcare with better building design*. New York: Library of congress.
- Montague, J., 1984, Hospitals in the Muslim Near East: a historical overview. *Architecture in development*, pp 52-69.
- Nightingale, F., 1863, *Notes on hospitals*. Third edition, London: Savill and Edwards.

- Otis, Reinhart, 2009, Daylighting rules of thumb, Harvard university graduate school.
- O'Connor, J., *Tips for daylighting*. Berkeley: Lawrence Berkeley National laboratory.
- Ruga, W., 1989, Designing for the six senses. *Journal of healthcare interior design*, 1, pp 29-34.
- Trezenga, P., 1998, *Desktop guide to daylighting for architects*, New and renewable energy programme.
- Ulrich, R., 2004, Effects of healthcare architecture on medical outcomes, Designing the 21 century hospital, Washington DC, June 3.
- Ulrich, R., 1984, View through a window may influence recovery from surgery. *science*, 224, pp 420-421
- Ulrich, R., 1986, Human responses to vegetation and landscapes. *landscape and urban planning*, 13, pp 29-44.
- Van den Berg, A., 2005, *Health impacts of healing environments*, Foundation 200 years university hospital Groningen.
- Verderber, S., 2010, *Innovation in hospital architecture*. Oxon: Routledge.
- Vittori, Guenther, 2008, *Sustainable healthcare architecture*. New Jerse: Wiley.

Thermal comfort study of university students in Jakarta, Indonesia

Tri Harso Karyono¹⁾, **Sani Heryanto**²⁾, **Ida Faridah**³⁾

¹⁾ School of Architecture, Tanri Abeng University (TAU), Indonesia;
E-mail: tkaryono15@gmail.com; t_karyono@tauniversity.ac.id

²⁾ School of Architecture, Tarumanagara University (Untar), Indonesia;
E-mail: sanikuo@yahoo.com

³⁾ School of Architecture, Mercu Buana University (UMB), Indonesia;
E-mail: idafaridah91@yahoo.com

Abstract

Thermal comfort study has been conducted in two Jakarta's private universities, namely Tarumanagara University (Untar) and Mercu Buana University (UMB). Ninety architecture students involved in this study, collecting 900 thermal votes from various indoor temperature conditions. Comparing to the previous study done in Jakarta in 1993 the result of this study was quite different, subjects were comfortable in much lower temperature. Even when compared with the previous study in Bandung with a lower outdoor temperature, subjects' comfort temperature in this study was about similar.. Since the study has also collected information about the use of AC by the subjects in their accommodations, this study revealed that nearly 100% subjects of Untar students had been using AC in their accommodations, while for the UMB students less than 50% subjects had been living in AC accommodations. This paper discusses the whole study and draws some conclusions from it.

Keywords: air conditioning (AC), undergraduate students, Indonesia, thermal comfort

1. Introduction

Jakarta is the capital of Indonesia located at 6° South Latitude which is close to the Equator. It has two seasons throughout the year: dry and rainy seasons. Since this city is in the warm, humid tropical climate, the diurnal and annual climatic variations are very small. In the rainy season the daily outdoor temperature is between 22 and 32°C while in the dry season is about 24 to 34°C. The temperature variations between the two seasons is very little. The monthly average outdoor temperature is then about the same throughout the year, although in the rainy season the outdoor temperature is slightly a bit lower than in the dry season. This kind of condition also happens in other cities throughout the country. Based on this condition, using the monthly average outdoor temperature as a factor to measure the degree of thermal adaptation can be fairly acceptable in this study.

Like in other developing countries, the economic development of Indonesia raises some concerned about the uncontrolled use of energy. In the past, most of the low income people in this country were unable to use some of the modern technology like AC. Today, people are becoming richer and are easily getting the access to cool their houses and buildings by installing AC. Even in a number of low income houses, AC is something that commonly used today.

Within the past 20 years, the use of AC in the houses and buildings has been escalated dramatically in this country. Even there are no available data to support this

statement, it would be uneasy to find a non AC building in the Indonesian towns today. Children from the haves born in this period of time have certainly experienced their whole life in the AC rooms, either in their houses or in the buildings, where they commonly used everyday like classrooms, library, shops, and other public buildings.

The phenomena of the changes of the immediate environment like building, from naturally ventilated (NV) to air conditioned, would be predictable changing the comfort temperatures required by the people. The changes of the indoor air temperatures, from high or medium levels in the NV building to become a low level in the AC building would be predictably reduce the comfort temperature required by the people. This study is an attempt to see these phenomena, whether a lower indoor temperature in the building due to the use of AC would affect to the decrease of people comfort temperature.

In order to do that, thermal comfort study was conducted in two Jakarta's private Universities namely Tarumanagara University (Untar) and Mercu Buana University (UMB). These two universities are different mainly on the students' economical background. With about twice as expensive as its tuition fees, Untar students, mostly come from the haves families, while UMB students mostly come from the middle income families.

2. Methodology

Comfort measurements in Untar were carried out on 29 April 2013 (the beginning of the dry season) and 11 September 2013 (the beginning of the rainy season), while the measurements in UMB took place on 22 May 2013 (about in the dry season). Both Untar and UMB campuses are located in Jakarta and they are separated each other by about 10km.

The measurements both in Untar and in UMB were carried out in the lecture rooms which were modified slightly to resemble a 'thermal chamber'. The rooms were blocked from any air infiltration from the outside. To have such indoor climatic variations, the rooms were firstly cooled by split-AC machines before use for the measurements. Students were asked to enter the classrooms and sit inside about 10 minutes after the AC had been turned off, aiming to provide a homogeneous indoor temperature.

There were 54 architecture students consisted of 30 males and 24 females involved in the Untar study and collecting 468 comfort votes. Students were entering the room about 10 minutes after the AC machines were turned off. The students took their seats and engaging in light activities like reading and chatting. In UMB, there were 36 students of 20 males and 16 females involved in the study, collecting 432 comfort votes. Like in Untar, students were entering the room about 10 minutes after the AC machines in the room were turned off. The students took their seats and engaging in light activities like reading and chatting. In total both studies have involved 90 subjects of Architecture students, collecting 900 thermal votes from various indoor temperature conditions.

All the measurements in Untar and UMB were using exactly the same instruments: alcohol thermometers measures air temperature, a 15cm-diameter globe thermometer painted black using alcohol thermometer to measure radiant temperature (globe temperature), a digital thermo-hygrometer to measure air relative humidity and a digital indoor anemometer to measure air velocity. In every measurement all the instruments were placed on the wood chair at about 80 cm from the floor and located about in the middle of the room.

In Untar study, 17 different indoor climatic parameters (air temperature, globe temperature, relative humidity and air movement) were measured using instruments described above. Along with the measurements of indoor climatic parameter, subjects' thermal sensations were measured at the same time by using a seven-scale thermal sensation vote: Cold (-3), Cool (-2), Slightly cool (-1), Neutral (0), Slightly warm (+1), Warm (+2) and Hot (+3). There were 54 subjects involved in the Untar study, collecting 468 thermal votes.



Figure 1. Measurements in Untar

In UMB study, measurements were conducted similarly to that of Untar in which 12 different indoor climatic parameters (air temperature, globe temperature, relative humidity and air movement) were measured using the same instruments as Untar. Along with the indoor climatic parameter measurements, subjects' thermal sensations were measured at the same time by using a seven-scale thermal sensation vote: Cold (-3), Cool (-2), Slightly cool (-1), Neutral (0), Slightly warm (+1), Warm (+2) and Hot (+3). There were 36 subjects involved in the UMB study, collecting 432 thermal votes.



Figure 2. Measurements in UMB

A number of ways to calculate subjects' neutral (comfort) temperature are available. ISO 7730-2005 (ISO 7730, 2005) defines these terms into three categories A, B and C in which A category is defined as $PPD < 6\%$ and $PMV > +0.2$, the B category is defined as $PPD < 10\%$ and $PMV > +0.5$ and the C category is defined as $PPD < 15\%$ and $PMV > +0.7$.

However, this paper would not use this way to classify comfort conditions, rather it will be applying a rather simple way to define subjects comfort temperature and comfort range. In this study, neutral or comfort temperature (T_n) is defined as AMV (actual mean vote) equals to zero or 95% of subjects would be felt neutral, while the comfort range would be defined in two categories A and B. The A category of comfort range T_{cr} (A) is defined as AMV is between -0.5 and +0.5 or about 90% of subjects felt neutral, while the B category of comfort range T_{cr} (B) is defined as AMV is between -1 and +1 or about 75% of subjects felt neutral. The correlation between

the AMV values and the percentage of the number of subjects would be felt comfortable is based on ISO 7730-2005 (ISO 7730, 2005).

3. Data and Analyses

3.1. Data of subjects

Subject of Untar study consists of 30 males and 24 females, made up the total of 54. Table 1 shows the statistical data of Untar subjects. From Table 1 it can be seen that Untar subjects were between 19 and 24 year of age with an average of 20.7 years and standard deviation (SD) of 0.98 years. In terms of height, the shortest subject was 152 cm and the tallest was 185cm with an average of 167.4cm and SD of 7.12 cm. Subjects' weights were between 44 and 105kg with an average of 63.1kg and SD of 12.7kg. The DuBois area or the body surface area (BSA) of the subjects formulated as $BSA = (W^{0.425} \times H^{0.725}) \times 0.007184$ is calculated by using BSA calculator of Cornell University School of Medicine (Cornell University, website, 2014) were found to be between 1.38 and 2.1 m² with the average of 1.71 m² and SD of 0.18m².

Table 1. Data of Untar subjects

	Age (yr)	Height (cm)	Weight (Kg)	DuBois area (m ²)
N	54	54	54	54
Min	19	152	44	1.38
Max	24	185	105	2.1
Mean	20.7	167.4	63.1	1.71
Standard Deviation (SD)	0.98	7.12	12.7	0.18

In the UMB study, there were 36 students involved in this study, consisting of 20 males and 16 females. Table 2 shows data on UMB subjects. It can be seen from Table 2 that subjects were between 18 and 25 year of age with an average of 20.4 years and SD of 1.69 years. In terms of height, the shortest subject was 148 cm and the tallest was 180cm with an average of 165.6 cm and SD of 6.13 cm. Subjects' weights were between 40 and 80kg with an average of 54.4kg and SD of 8.44kg. The DuBois area of the subjects was between 1.29 m² and 1.93 m² with an average of 1.59 m² and SD of 0.17m².

Table 2. Data of UMB subjects

	Age (yr)	Height (cm)	Weight (Kg)	DuBois area (m ²)
N	36	36	36	36
Min	18	148	40	1.29
Max	25	180	80	1.93
Mean	20.4	165.6	54.4	1.59
Standard Deviation (SD)	1.69	6.13	8.44	0.17

3.2. Data of indoor climatic parameters

Table 3 shows the indoor climatic data of Untar study. The indoor air temperatures were between 22 and 30°C with an average of 26.2°C and SD of 2.67°C, while the globe temperatures were between 19 and 29°C with an average of 24.5°C and SD of 3°C. The indoor RH ranged between 60 and 70% with an average of 66.9% and SD of 4.1%. Measured by an anemometer, it was also noticed that the indoor air was still during the measurement.

Table 3. Data of indoor climatic parameters of Untar study

	Air temperature T_a (°C)	Globe temperature T_g (°C)	Relative humidity RH %	Air Velocity (m/s)
N	17	17	17	17
Min	22	19	60	Negligible (Still)
Max	30	29	70	
Mean	26.2	24.5	66.9	
Standard Deviation (SD)	2.67	3	4.1	

Table 4 shows the indoor climatic measurement in UMB. The indoor air temperatures were between 23 and 30°C with an average of 27.3°C, while the globe temperatures were between 21 and 29.5°C with an average of 24.5°C. The indoor RH ranged between 67 and 80.8% with an average of 71.7%. As in Untar, it was noticed that the indoor air was still during the measurement.

Table 4. Data of indoor climatic parameters of UMB study

	Air temperature T_a (°C)	Globe temperature T_g (°C)	Relative humidity RH %	Air Velocity (m/s)
N	12	12	12	12
Min	23	21	67	Negligible (Still)
Max	30	29.5	80.8	
Mean	27.3	24.5	71.7	
Standard Deviation (SD)	2.03	2.64	4.4	

3.3. Distribution of subjects' thermal sensation

Table 5. Distribution of subjects' thermal votes of Untar study

Meas- urem- ent	Temperature		Thermal vote								No of subject
	Air Temp (°C)	Globe Temp (°C)	-3 Cold	-2 Cool	-1 Slightly cool	0 Neutral/ comfort	+1 Slightly warm	+2 Warm	+3 Hot	Mean vote	
1	22	19	0	1	12	15	2	0	0	-0,4	30
2	24	21	0	0	1	20	7	2	0	0,3	30
3	25,5	22	0	0	1	17	10	2	0	0,4	30
4	26	24	0	0	1	10	13	6	0	0,8	30
5	26,5	25	0	0	0	6	12	12	0	1,2	30
6	27,5	26,5	0	0	0	4	12	13	1	1,4	30
7	28	28	0	0	0	4	10	15	1	1,4	30
8	29	28	0	0	0	1	10	14	5	1,8	30
9	29,5	28,5	0	0	0	1	5	18	6	2	30
10	30	29	0	0	0	1	6	16	7	2	30
11	22	22	2	6	7	8	1	0	0	-1	24
12	24,5	23	0	1	6	13	4	0	0	-0,2	24
13	26	25	0	0	3	11	10	0	0	0,3	24
14	27	26	0	0	0	13	10	1	0	0,5	24
15	27,5	26,5	0	0	0	11	11	2	0	0,6	24
16	28	27	0	0	0	11	9	4	0	0,8	24
17	28,5	27,5	0	0	0	7	11	6	0	0,9	24
Total			2	8	31	153	143	111	20		468
Percentage			0.4%	1.7%	6.6%	32.7%	30.6	23.7	4.3%		100%

Table 5 shows the distribution of subjects' thermal votes of Untar study. Within the air temperature of between 22°C T_a and 30°C T_a and globe temperature of between

19°C T_g and 29°C T_g subjects' thermal votes were distributed in such a way in which out of 468 votes, 153 (32.7%) were neutral, nearly 60% of thermal votes were in the warm and hot sides and only less than 10% were in the cool sides. This means that the subjects were likely to be comfortable within the temperature, which is closer to 22°C T_a (or 19°C T_g) than to 30°C T_a (or 29°C T_g).

Table 6 shows the distribution of subjects' thermal votes of UMB study. Within the range of air temperature of 23°C T_a and 30°C T_a and globe temperature of between 21°C T_g and 29.5°C T_g subjects' thermal votes were distributed in such a way in which out of 432 votes, 114 (26.4%) were neutral, about 67% of thermal votes were in the warm and hot sides and only about 7% were in the cool sides. This means that the subjects were likely to be comfortable within the temperature, which is closer to 23°C T_a (or 21°C T_g) than to 30°C T_a (or 29.5°C T_g).

Table 6 Distribution of subjects' thermal votes of UMB study

Measurement	Temperature		Thermal vote								No of respondent
	Air Temp (°C)	Globe Temp (°C)	-3 Cold	-2 Cool	-1 Slightly cool	0 Neutral/comfort	+1 Slightly warm	+2 Warm	+3 Hot	Mean vote	
1	23	21	2	4	11	16	3	0	0	-0.6	36
2	25	23	0	2	2	25	7	0	0	0	36
3	26	24	0	0	4	19	12	1	0	0.3	36
4	26.5	25	0	0	3	11	19	3	0	0.6	36
5	26.5	26	0	0	1	12	19	4	0	0.7	36
6	27	26.5	0	0	0	9	22	5	0	0.9	36
7	27.5	27	0	0	0	5	24	6	1	1.1	36
8	28	27.5	0	0	0	7	21	7	1	1.1	36
9	28.5	28	0	0	0	5	16	15	0	1.3	36
10	29.5	29	0	0	0	4	8	24	0	1.6	36
11	29.5	29.2	0	0	0	1	3	24	8	2.1	36
12	30	29.5	0	0	0	0	2	19	15	2.4	36
Total			2	6	21	114	156	108	25		432
Percentage			0.5%	1.4%	4.9%	26.4%	36.1%	25%	5.8%		100%

3.4. Neutral temperature and comfort range

3.4.1. Neutral temperature and comfort range of Untar study

Fig 3 shows the regression line of comfort votes against air temperature (T_a). This regression produces an equation of $AMV = 0.316T_a - 7.628$, with a coefficient of determination (R²) of 0.457. The correlation between AMV and T_a is significant at 0.01 level (2-tailed).

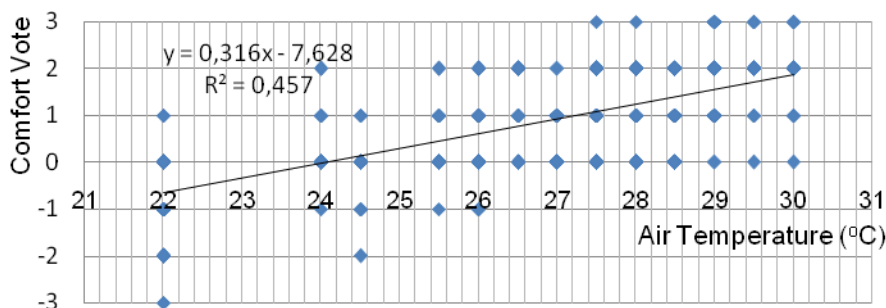

Fig 3 Regression line of thermal vote on air temperature

Figure 4 shows the regression line of comfort votes against globe temperature (T_g). This regression produces an equation of $AMV = 0.231T_g - 5.019$, with a coefficient of

determination (R^2) of 0.376. The correlation between AMV and T_g is significant at 0.01 level (2-tailed).

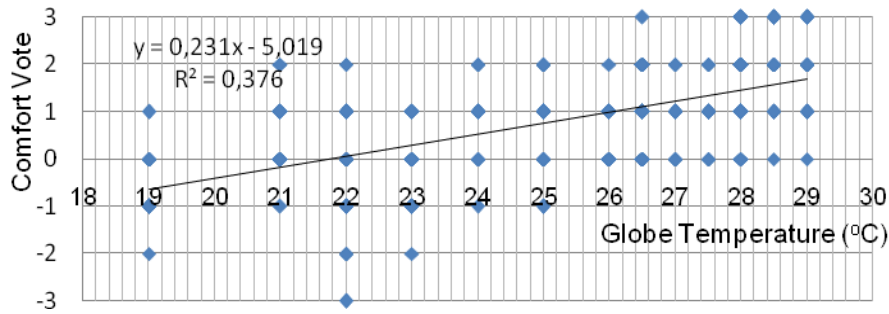

Fig 4 Regression line of thermal vote on globe temperature

Table 7 shows the neutral (comfort) temperature and comfort range of the Untar subjects. From this table it can be seen that in terms of air temperature, subjects neutral temperature of Untar study is 24.1°C T_a , while T_{cr} (A) is 22.6 - 25.7°C T_a and T_{cr} (B) is between 21 - 27.3 °C T_a . While in terms of globe temperature, subjects neutral temperature of Untar study is 21.7°C T_g , while T_{cr} (A) is 19.6 to 23.9°C T_g and T_{cr} (B) is between 17.4 - 26.1 °C T_g

Table 7. Neutral temperature (T_n) and comfort range (T_{cr}) in terms of air and globe temperature of Untar study

	T_a (°C)	T_g (°C)
Neutral temperature (T_n , ± 95% comfortable)	24.1	21.7
Comfort range A (T_{cr} , ± 90% comfortable)	22.6 - 25.7	19.6 - 23.9
Comfort range B (T_{cr} , ± 75% comfortable)	21 - 27,3	17,4 - 26,1
Regression equation	$Y = 0,316X - 7,628$	$Y = 0,231X - 5,019$
Coefficient determination (r^2)	0,457	0,376

3.4.2. Neutral temperature and comfort range of UMB study

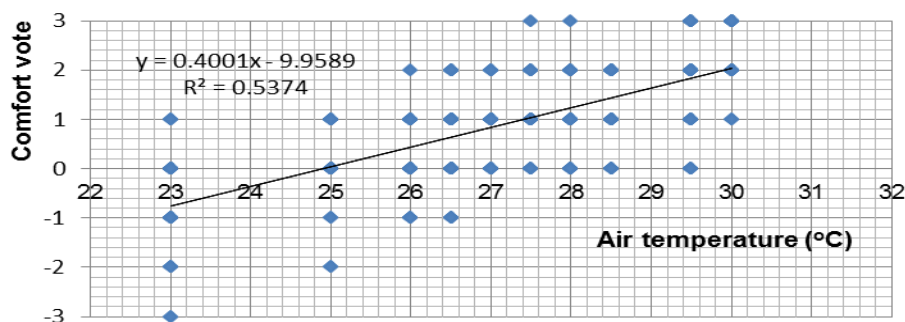

Fig 5 Regression line of thermal vote on air temperature

Fig 5 shows the regression line of comfort votes against air temperature (T_a). This regression produces an equation of $AMV = 0.4001T_a - 9.9589$, with a coefficient of determination (R^2) of 0.537. The correlation between AMV and T_a is significant at 0.01 level (2-tailed).

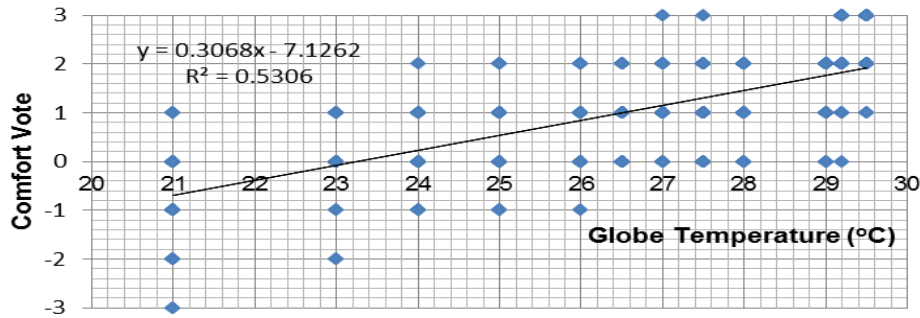

Fig 6. Regression line of thermal vote on globe temperature

Fig 6 shows the regression line of comfort votes against globe temperature (T_g). This regression produces an equation of $AMV = 0.3068T_g - 7.1262$, with a coefficient of determination (R^2) of 0.531. The correlation between AMV and T_g is significant at 0.01 level (2-tailed).

Neutral (comfort) temperature and comfort range of the UMB subjects are calculated from the regression equations in Fig 5 and 6 and they are presented in Table 8. It can be seen from the table that in terms of air temperature, subjects neutral temperature of UMB study is $24.9^\circ\text{C } T_a$, while T_{cr} (A) is 23.6 to $26.1^\circ\text{C } T_a$ and T_{cr} (B) is 22.4 to $27.4^\circ\text{C } T_a$. While in terms of globe temperature, subjects neutral temperature of UMB study is $23.3^\circ\text{C } T_g$, while T_{cr} (A) is 21.7 to $24.9^\circ\text{C } T_g$ and T_{cr} (B) is 20 to $26.6^\circ\text{C } T_g$.

Table 8. Neutral temperature (T_n) and comfort range (T_{cr}) in terms of air and globe temperatures of UMB study

	T_a ($^\circ\text{C}$)	T_g ($^\circ\text{C}$)
Neutral temperature (T_n , $\pm 95\%$ comfortable)	24.9	23.3
Comfort range A (T_{cr} , $\pm 90\%$ comfortable)	23.6 – 26.1	21.7 - 24.9
Comfort range B (T_{cr} , $\pm 75\%$ comfortable)	22.4 – 27.4	20 - 26.6
Regression equation	$Y = 0.400 - 9.958$	$Y = 0.306 - 7.126$
Coefficient determination (r^2)	0.537	0.53

4. Discussions

Looking through Tables 7 and 8 we can see that subjects' comfort temperature of Untar study was $24.1^\circ\text{C } T_a$ ($21.7^\circ\text{C } T_g$) while the UMB study was $24.9^\circ\text{C } T_a$ ($23.3^\circ\text{C } T_g$). The results of this study were quite surprising. Although the study was conducted in Jakarta with the mean monthly outdoor temperature of about 28°C , subjects' comfort temperature was found to be much lower than that of the comfort study done in Jakarta in 1993 (Karyono, 2000). To be compared with a previous comfort study in Bandung in 2006 (Karyono, 2008) with a lower monthly outdoor temperature of $24^\circ\text{C } T_a$, subjects' comfort temperatures of Untar and UMB were about similar to that of Bandung study.

Since the recent Jakarta study collected also the information about whether subjects were using AC in their accommodations, this study revealed that nearly 100% subjects of Untar students using AC in their accommodations, while for the

UMB students less than 50% subjects having AC in their accommodations. All the classrooms, both in Untar and UMB were air conditioned.

It can be seen in Table 5 and 6 that the classrooms' temperatures in both Untar and UMB were usually being set at about 22 and 23°C (at the beginning of the measurements, after the AC were just about to be turned off). Since the subjects were having such daily experiences in a quite low classroom temperature, it is predicted that subjects would be comfortable in a low temperature, which is close to 22 and 23°C as in the classroom's temperatures they usually experienced.

In the case of Untar, where nearly 100% of the subjects live in the AC accommodations, it can be predicted that the subjects would have experienced in the similar situation as in the classrooms. While for the UMB subjects, there would be only some of them would have a similar thermal condition as in the classroom as only some of them living in the AC accommodations. Therefore, it was found in this study that the UMB subjects were comfortable, or achieving neutral temperature, in the slightly higher temperature than the Untar subjects.

Comfort study done in Jakarta by the author in 1993 (Karyono, 2000) showed that comfort temperature of subjects, who were about the same age as the students in this study, was 26.4°C T_a and this is about 1.5 degrees higher than this studies in the two Jakarta's universities. The college-age subjects in the 1993 Jakarta study were low-rank workers in their offices and came from low-medium income families which, predictably had no AC in their accommodations. While, a previous comfort study in 2006 in Bandung (Karyono, 2008) with an average monthly outdoor temperature around 23°C showed that subjects' comfort temperature was 24.7°C. Since Bandung average daily and monthly temperature were quite low, not many people would have AC in their accommodation. The indoor temperature in Bandung would be similar or slightly higher than the outdoor, resulting in the low subjects' comfort temperature in that study.

Some thermal comfort studies show that comfort temperature is affected by the average running temperature that a person experiences (Nicol, 1993). Into some extent, the higher the average running temperature experienced by a person, the higher the comfort temperature would be for this person (Nicol, et al, 2012). People live in the tropical environment tend to have a higher comfort temperature than those live in the temperate climate. Assessing some studies conducted by a number of researchers in some South East Asia countries, Karyono (Karyono, 1996) found that the comfort range was between 20 and 31°C, higher than the average comfort range in the temperate region. In 2010 Humphreys et al comparing data from comfort studies done after 1978 and the Humphreys' graph of 1978 (Nicol, et all, 2012). It was found that the mean comfort temperature for any given outdoor temperature has risen by about 2K. Whatever the reason, this was predicted that there was a changing in the indoor temperature that people experienced which leads to the changes of their comfort temperature.

At the moment result of this study looks in line with the Adaptive rule that physically people tend to adjust to their thermal environment where they have been exposed for a long time.

5. Conclusions

It was found from the study that comfort temperature of Untar subjects in this study was 24.1°C T_a (21.7°C T_g) while the UMB subjects was 24.9°C T_a (23.3°C T_g). These figures are lower than the previous comfort study done in Jakarta in 1993. Furthermore, these comfort temperatures are also found to be similar to the comfort

temperature of Bandung students lived in a lower monthly average outdoor temperature.

This study has shown that there is a decreased by about 1.5K on the college-age students' comfort temperature within the last two decades. Although this is still a matter of speculation, a decrease of about 1.5 degrees could have been caused by the changes of the indoor thermal environment that the subjects have experienced from warm to cool due to the use of massive air conditioners in the buildings within the last 20 years.

If this is the case, the massive use of AC in the buildings within the last two decades seems likely has decreased the comfort temperature requirements of people live in the big city like Jakarta. It could be possible that people tend to be more comfortable at a lower temperature than before as they have been exposed to the lower temperature environment. The improvement of the peoples' economy gives more people the chance to have more access to the use of modern technology like AC, lowering the indoor temperature and reducing people thermal comfort requirements. This could cause to the escalation of building energy consumption in the developing countries like Indonesia.

Acknowledgements

The authors wish to thank all students who participated in this study. Since part of this work is financed by the Tarumanagara University, the authors, therefore, wish to thank them for providing the funding.

References

- Cornell University School of Medicine, Body Surface Area (BSA) calculator viewed at <http://www-users.med.cornell.edu/~spon/picu/calc/bsacalc.htm> on 16 January 2014
- International Standard, ISO 7730, Third edition 15 November 2005
- Karyono, T.H. (1996), Thermal Comfort in the Tropical South East Asia Region, *Architectural Science Review*, vol. 39, no. 3, September, pp. 135-139, Australia.
- Karyono T.H. (2000), Report on Thermal Comfort and Building Energy Studies in Jakarta, *Journal of Building and Environment*, vol. 35, pp 77-90, Elsevier Science Ltd., UK.
- Karyono, T.H. (2008), Bandung Thermal Comfort Study: Assessing the Applicability of an Adaptive Model in Indonesia, *Architectural Science Review*, vol. 51.1, March, pp. 59-64, Australia.
- Nicol, F.J. (1993). *Thermal Comfort: A Handbook for Field Studies toward an Adaptive Model*. London: University of East London.
- Nicol, F, Roaf, S, Humphreys, M (2012), *Adaptive Thermal Comfort: Principles and Practice*

African Green Design Solutions as Vernacular Bioclimatic Architecture

Tokie Laotan-Brown

PhD Scholar in Economics and Techniques for the Conservation of the Architectural and Environmental Heritage at the University of Nova Gorica and Università Iuav di Venezia, Italy.

Abstract: This lifelong interaction between the cognitive and physical realms has existed overtime. During the evolution of design solutions inhabitants adapted form and materials to the conditions of nature; working with natural forms and climatic cycles rather than considering forces as obstacles to overcome has hermeneutic and practical values; used by intentional makers. The cultural identity in the inhabitant made the home, and then the process of home-making ‘made’ the inhabitant; a common reward. This will include their connection to the culture, region and environment while proposing a design solution. The future of African design solutions, need to take lessons from the past into the future through present resolutions.

Keywords: Bioclimatic, Design Solutions, Vernacular

Introduction

The divorce from nature by humans has been on the increase in the last hundred years and this has been evident even in the African built environment. This paper will look at how past African design solutions can be viewed as modern bioclimatic architecture. Historically, Africans have built shelters with materials that can be sourced locally and while being adapted to building technologies, as well as to the natural cycles of the environment. Cook, et al. (2011) describes this construction of building as a response to local climate and inherently linking the people to the local ecosystem. The introduction of environmental design that embraces restorative ideologies can impact on landscapes and the built environment while improving the impacts made on the natural environment. In Millen, K. (2013), she discusses how occupants residing in an ecological and culturally sustainable environment can also benefit from the natural elements associated with wellbeing. This shift in ideology to embrace the outside within the inside is apparent in Kellert, (2004) which sees this paradigm as a requirement of a new bioclimatic ethic towards the natural world.

This paper argues that planning is culturally and contextually defined, and the specificities of a place are critical in planning. Developing strategies based on indigenous vernacular forms that embody local peoples' cultures, aspirations, experiences, and values is consistent with the concept of vernacular African design solutions, which is the central theme of this paper. This paper also contributes to the green design solutions debate by emphasizing and bringing into the debate and discussion the African perspective, which is missing in green design solutions dialogue. Although the problems confronting contemporary African cities are much greater than what existed in pre-colonial African cities, it is imperative to examine the town and city structures, forms, ideas, and concepts of pre-colonial times and places, because an understanding of indigenous vernacular architecture can contribute to bioclimatic design solutions.

Our current understanding that bioclimatic architecture was an indigenous and recurrent phenomenon in West African Savannah and the Sahel dates largely to the postcolonial period. In the colonial imagination, Africa was predominantly rural in character, composed of small, undifferentiated villages of mud and thatch huts. The walled cities and towns of the Sahel (Kano province alone had 170 in 1900) were, consequently, a colossal surprise to Europeans. Frederick Lugard commented in 1902 before his assault on Kano that "I have never seen, nor even imagined, anything like it in Africa" (quoted in Connah 2000, 43). Colonial era historians and archaeologists accommodated this urban anomaly by "medievalizing" the Sahel and conceptualizing it as an economic and cultural dependent of the Islamic world. Cultural and political achievements in the Sahel were attributed to influences from the north. This diffusionist paradigm formalized the belief that bioclimatic architecture was not native to Africa.

Farther south, European administrators and anthropologists did not recognize the large, densely populated, nucleated Yoruba settlements as bioclimatic in character. Why was this? One of the main obstacles to the recognition of pre-colonial African vernacular bioclimatic architecture was that all the conceptual tools available for investigating this topic had been developed with reference to Western sequences of historical development. The bulk of the ideas on what cities are and how they have changed through time dealt with European design solution transformations from classical antiquity through the Middle Ages and the Industrial Revolution. Thus, many nineteenth – and early-twentieth-century attempts to define the term bioclimatic proceeded by constructing ideal types that identified essential features differentiating Western design solutions from pre – or non design solutions.

The archaeologist V. G. Childe constructed a list of essential features of urban civilization, including writing and monumental architecture, thereby excluding much of black Africa from consideration. The West has long thought of cities as centres of despotic power, with impressive architecture reflecting that power. It is now recognized that monumentality, while a common strategy employed by rulers of early city-states in Mesoamerica and Mesopotamia (among others), was not an inevitable accompaniment of early design solutions. The Bronze Age cities of China, for example, had no monumental architecture. Among the reasons for the lack of investment in monuments in much of Sub-Saharan Africa are lack of suitable building

materials (such as stone) in some areas and the prevalence of extensive, slash-and-burn agricultural systems that required settlement relocation after several decades, thus working against permanent installation of populations at one location for long periods. In many areas, the location of the capital landscape city shifted with every accession of a new ruler. Ecological constraints linked to a value system that conceived of space as social (rooted in kin groups and genealogical proximity), rather than as a particular physical place, produced African urban landscape configurations that looked quite different than the cities of the West.

All of this helps explain why European observers failed to recognize African towns and cities: because they did not conform to concepts of green design solutions derived from Western bioclimatic sequences. The postcolonial period has seen a reorientation of research that has exposed the ethnographic assumptions and ideological underpinnings of many of the earlier theories of urban – ism. Emphasis has shifted from what a city is (widely agreed to be a futile pursuit in view of the tremendous range of urban forms) to what a city does. We owe to geographers the important realization that urban landscapes never exist in isolation; they are always articulated with a regional hinterland. Whatever else a city may be, it is a unit of settlement that performs specialized functions in relation to a broader hinterland. The specialized functions may be of an economic nature, such as production and export of goods and services, or they have a more social aspect, such as the elaboration of power and new social institutions or the exchange of information. Urbanism thus represents a novel kind of relationship among sites in a region involving the emergence of specialization and functional interdependence. The symbiosis characteristic of the urban landscape system emerges out of the circulation of commodities essential to subsistence (food, iron used to produce food) within it. Urban landscape systems are predicated upon the exchange of agricultural surplus. Their characteristic spatial signature is a hierarchy of higher and lower order settlements in which higher order sites are larger and more populous and fill a wider range of specialized functions than lower order settlements.

In the light of the above, this paper examines the role African vernacular architecture can play in addressing green design solutions. In addition, this paper addresses the following questions. Could the incorporation of indigenous African vernacular forms, ideas, and concepts into the contemporary city-building process in Africa contribute to bioclimatic architecture? Thus, taking into consideration the urbanization challenges and problems of cities in Africa? Why have native architecture and vernacular forms been rejected and replaced with Western urban designs and architecture, and how do we promote the incorporation of indigenous local forms, ideas, and concepts into the urban development process in Africa? This paper relies on secondary sources of data for review and analysis of the characteristics of indigenous African vernacular forms; sustainable green solutions; and characteristics, conditions, problems, and challenges of contemporary African cities addressing bioclimatic architecture.

Addressing African Vernacular Instincts in the Green Built Environment

This paper fits alongside existing works on the understanding and merits of vernacular architecture so it is important to understand the work already done in the field. It has been recognised by many that indigenous populations find often ingenious designs for buildings to tailor them to the local climatic conditions Stevenson. (2000). Thus, design solutions have to be low energy or zero energy by the very nature of the economics of the locale. It therefore stands to reason that such techniques must also have been prevalent in African countries, and that these techniques have been long lost and forgotten. If the ideas could be rediscovered then it may be possible to incorporate such design features into contemporary structures to increase comfort levels whilst reducing energy needs.

Vernacular knowledge, to coin a phrase, extends beyond the simple building blocks of the construction to incorporate such aspects of the build as siting and orientation of the structure to work with the environment rather than against it Oliver, P.(2006). This should also be considered when looking at how the structures themselves work, and what we can learn from them. The vast majority of the work already done in this area has focussed on Western solutions for African architecture, rather than thinking about techniques that may facilitate energy reduction in the African built environment through environmentally sympathetic building design. Despite this geographical focus, pre-existing work from other parts of the world is important in understanding mechanisms for coping with climatic challenges as the world wakes up to the reality of climate change.

There is a wider question of what climate we should now be designing for in this changing environment, perhaps it would be prudent to adopt ideas from the African vernacular for modern bioclimatic design (Roaf et al, 2005)? Could this be a better methodology than relying on often power hungry technology to enhance our built environment to mitigate a changing external climate? According to Heerwagen, J. (2008) the characteristics of the natural environments that are present, ensures that human beings tend to feel calmer, more comfortable and less stressed and thereby improving their sense of wellbeing. Heerwagen, J. (2008), in her book, Psychological Value of Space- Whole Building Design Guide (WBDG), states that the work environment has been designed to separate occupants from nature, which is the modern office building where people work. The daily lives of residing in an urbanized city has ensured that working in offices with no windows at eye level, underground subway, spending evenings indoors watching tv has further estranged humans from natural regions, where villages are increasingly extended and the countryside loses its lure to residential urbanized areas (Joye, Y. 2007, Millen, K. 2013).

Africa is perceived as a paradise rich in plant and animal life; however, despite the abundance of life these areas require distinct architectural solutions to facilitate a degree of comfort to the living conditions. The climate of African countries is defined by both warmth and extremely high humidity levels. Temperatures tend to average at 24 degrees C or more under the canopy, and annual rainfall ranges from between 1.5m and 3m (WWF, 2006). Historically, the local inhabitants of African regions have had to devise structures that work in these conditions, and as a result have come up with solutions to meet their needs which are very different from the buildings of Europe. In order to facilitate passive cooling, the building has to not only be designed in a way that encourages the purging of hot air from the building during the cooler periods but also orientated in such a way as to promote heat loss Chiras, D. (2002). In structural terms, Chiras points out that the building must incorporate features to minimise both internal and external heat gain through the use of features such as light

coloured external walls, overhangs, insulation and radiant barriers. Whilst not all of these features may have been historically available to the inhabitants of Africa a surprising number of these ideas can be seen amongst examples of African vernacular housing.

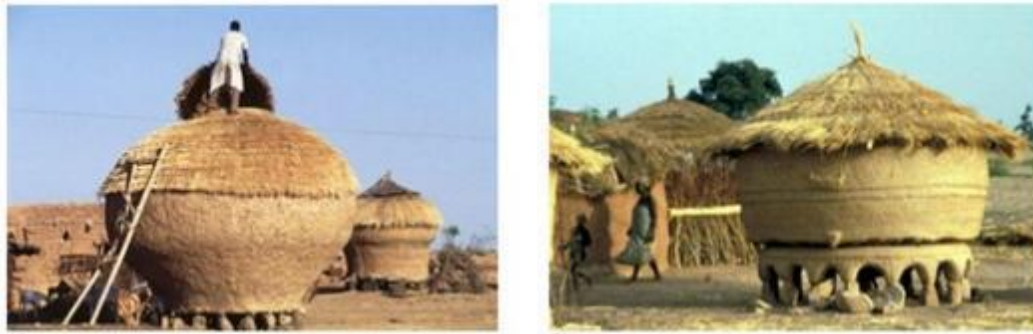

Granary-near Kankeya, Nigeria

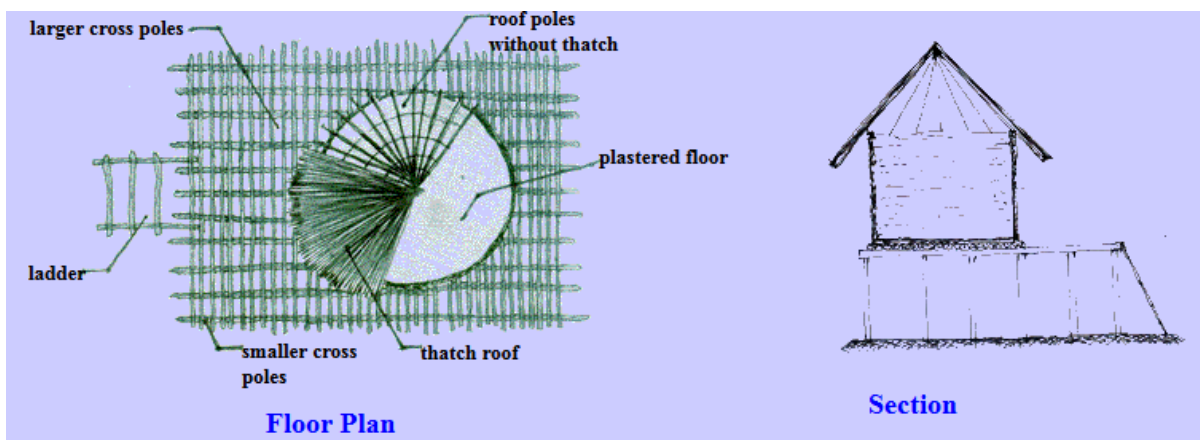

Culled from notes Laotan-Brown, T. (2013)

One of the key figures in the study of African vernacular architecture is Paul Oliver who spent time in the mid 1960s teaching at the Kumasi University of Science and Technology in Ghana. Kumasi is situated in the depths of Ghanaian Rainforest and offered Oliver the ideal opportunity to study the local architectural solutions to this hot, humid climate. What Oliver (2006) discovered was that the Asante people of the region had a sophisticated understanding of their environment illustrated by their use of giant Cottonwood trees to shade the ground below from the fierce heat of the sun, enabling cultivation below the canopy. Without the use of such cover the sun would bake the earth's surface into a concrete hard substance. This kind of cultural knowledge was something Oliver recognised not only through agriculture, but also in the dwellings both here and across different cultural groups. An example he gives of the use of this type of environmental knowledge in dwelling design and construction comes from the tropical east coast of Africa where the Swahili people build a mangrove timber framed structure and pack between the poles with mud. The gable ends of the roof space, however, are left open to promote ventilation of the structure to promote a comfortable internal environment.

Archaeology has long held the Africa as the cradle of civilisation, a place where people first made the shift from a nomadic hunter-gatherer existence of our African ancestors to a static agrarian culture Greene, K. (1994). There is a wealth of archaeological material showing this shift, and an architectural tradition stretching back from the present day into an ancient world long forgotten Hodder, (1996). Earth building has a long tradition throughout North Africa

and the Middle-East. In North Africa desertic soils consisting of a mix of broken rock and sand are just such a material Oliver, P. (2003). Not only are these materials readily available to the local inhabitants, but in performance terms they are also ideal for the harsh climate of the region, with the thick earthen walls lending the structure considerable thermal mass Biondi et al, (2006). Other materials also available locally are often incorporated into such buildings, as Biondi (2006) discovered in the Drâa Valley of Morocco.

In this area the villagers have to be prepared for flooding during the rainy season when the river bursts its banks, Biondi noticed that they incorporated a stone built lower section to the buildings to protect against both the water action during such events, as well as provide some resistance to the humidity levels that are associated with flood periods in the region. The earth is then built up onto one of these walls either as pisè or adobe bricks, with locally available palm wood used for internal floors and joists. Examples of this type of architecture exist back into antiquity within these generally arid regions, with the Arg-e Bam site in Iran dating back around 2000 years and still standing within the landscape Langenbach, (2004) illustrating the longevity of both the structures constructed in this way, but also in the architectural concept of the buildings which perform well within this climatic situation. Indeed Greene (1994) describes earth as being one of the most important ancient building materials due to both its availability and its climatic performance.

The move to building with earth, whilst being very ancient in origin, was made possible only by the shift from a nomadic hunter-gatherer society to a more sedentary agrarian based economy (Greene, 1994) with the earliest examples coming from western Asia where sun-dried bricks make their first appearance in Jericho in around 8000BC. This places the structures firmly at the early part of a period often referred to by archaeologists as the Neolithic, a time defined by the domestication of animals and the development of purposely planted crops (Hodder, 1996). The longevity of this technology by the people of these arid regions is testament to the performance of the material in providing a stable and comfortable internal climate to the dwellings Oliver, P. (2006). The materials used in these structures are not the only mechanism employed to foster a more comfortable existence for the occupants.

Green design solutions were an important architectural feature of indigenous African cities and the protection of fragile environments were critical elements underlying indigenous planning and design principles. The rural character of towns in pre-colonial Africa was the result of such practices. Gutkind (1963) revealed that the Yao tribe of east central Africa came to terms with urbanism by cultivating every plot of open and unused land within their settlements. This gave a serene impression of rural spaciousness, while at the same time providing easily accessible and fresh food to city residents. Hull (1976) revealed that, as a conservation measure, the well-spaced houses in eighteenth-century Mbanza Kongo developed by the *Bashilele* were built around existing trees to minimize the disruption of the ecological balance. And because it was a criminal offense to cut down a raphia or oil palm, builders had to accommodate themselves to the natural order of things (Hull 1976). They designed and built with nature, as McHarg (1969) terms it. Elsewhere, the Bangala towns in the present-day Democratic Republic of the Congo were bordered by rectangular patches of banana plants and double rows of palm trees laid out in straight lines (Hull 1976). In western and central Sudan, residential quarters within the oval-shaped towns were separated by green belts. These corridors of green belts were not purely for aesthetic purposes: they controlled urban spatial growth, and the farms and orchards that flourished on them supported the towns' inhabitants in times of war and famine. The Yoruba people of southern Nigeria attached great importance to gardening in cities; hence, Yoruba urban and house designs had

gardens as essential components, and this is reflected in Yoruba kings having elaborate and extensive gardens surrounding their royal palaces, referred to by Ojo (1966) as —forests enclosed within walls.

These techniques are employed to reduce the area of the building exposed to direct sunlight, and hence reduce the solar gain on the structure. However, it is noted by Asquith et al (2006) that these narrow shaded lanes have a minimal Sky View Factor, hence there is a poor exchange of heat between the space inside the lanes, and the sky. This reduces the night cooling effect on these spaces which could lead to heat build up from the day not escaping during the often cool nights experienced in these regions. In the past this was recognised and Asquith et al noticed that many traditional settlements were aligned such that prevailing winds were channelled up the streets and alleys to flush the heat from them, and provide additional cooling through convection and evaporation.

The cooling effect of evaporation was also recognised by the people living within the hot, arid regions in Africa. Dwellings in these regions are often built around a central courtyard in which a pool or fountain can be placed which has the effect of both cooling and humidifying the air as it passes over Oliver, P. (2006). Another technique often employed is to hang moistened mats over windows so the air passing through the material is again cooled and humidified by the water. Oliver notes that courtyard dwellings featuring such evaporative cooling methods have been excavated in Kahun, Egypt, and dated to around 5,000BC illustrating the antiquity of such techniques and their role in vernacular tradition. The action of air movement in providing a cooling influence on internal climate in arid regions is not the sole preserve of courtyards and alleyway, however, the wind catcher is such a development which works by capturing the cooler, faster moving air from above the settlement and transferring it into the living quarters below Asquith et al, (2006). Once again we find that the development of these devices can be traced a long way back into history, with papyrus drawings discovered in Egyptian tombs illustrating similar structures from 3,500 years ago Oliver, P. (2006), albeit in the more basic form of a wind-scoop which may be as simple as a layer of stretched fabric over a frame mounted above a building to deflect the wind down into the structure itself via a ventilation shaft. Oliver believes that the more elaborate examples of wind-catchers seem to have developed in the Gulf States of Iran and Iraq sometime around the fourteenth century.

African green design involves applying the forms and patterns of natural living systems to the creation of built environments and consumer products so that human activity sustains without harm and even regenerates the living systems of which humans are a part of (Mehaffy, M., & Salingaros, N. A. 2011, Hosey, L. 2012). Bioclimatic design include: day lighting and natural ventilation; organic forms and natural materials; visual diversity and views to nature; and access to plants, both inside and out (Kellert et al. 2011). These features are closely tied to familiar ideas of energy conservation and renewable materials. A vegetated roof, for example, which limits ambient heat build-up and reduces storm-water runoff, can also provide an urban garden and views of nature (Hosey, L. 2012). Natural ventilation can reduce cooling loads and air-moving equipment (Campbell, L. K., & Wiesen, A. 2011), while also providing fresh air. Carefully shaded glazing provides heat and light, without overheating or glare, while bestowing on interior spaces the subtle diurnal changes in the colour and quality of light (Heerwagen, J. 2008). Thermally massive walls combined with glazing that selectively filters heat and light for passive solar design as one of the principles of bioclimatic philosophy of "prospect and refuge" (Novitsky, B.J. 2009 and Timberlake, K. 2011). This directs back to early humans on the African savannah who felt sheltered at the forest's edge, while seeing prey in the distance (Kellert, S. R. 2003). What was once a matter of survival,

prospect and refuge now produces a sensation of comfort and safety? The absence of this sensation, as in buildings without views of nature, could result in anxiety and depression (Novitski, B. J. 2009).

African Vernacular Design Solution: Case study Venda Methodology- Congo to Zimbabwe.

It is believed that the Venda originally came from the Congo, and settled in Zimbabwe. The traditional Venda homestead was mainly created by the influence of the climate, topography, availability of material and the technical ability of the dwellers. According to Rapoport (1969), the house form is simply not the result of physical or any single factors but the consequence of socio-cultural factors. An example of this form seen around Africa as well is the tapered roof associated with agriculture in the region. This form is also different from the dome shaped roofs associated with nomadic livestock herdsman. This case study will acknowledge the socio-cultural factors but mainly focus on the rationale behind the factors



Venda Hut

in Mbilwe, Photo by A.M Dungan-Cronin (2005).

The huts are relatively small with simple structures. One of the reasons for this is that a large part of life is spent outdoors. The materials used for building these structures; timber, soil and grass. The natural environment is an integral part of the technical creation of the structure.



zones of the Kraal (1974)



Living terraces and Living

A *Kraal* was normally fenced with planted thorn bushes. The entrance to the compound, usually at the lowest point, is directly connected with the living areas without an internal courtyard. The living hut *Nndu* and the cooking hut, *tshitanga* are placed opposite each other with the cooking hut normally at the lower level than the living hut. In front of every hut is a partitioned off area used as a yard. The head of the *Kraal* lives on the highest point of the site with his wives on the lower areas. When a very steep site is chosen for the *Kraal*, terraces are used for the siting and orientation of each hut. The terraces are supported by low stone walls.

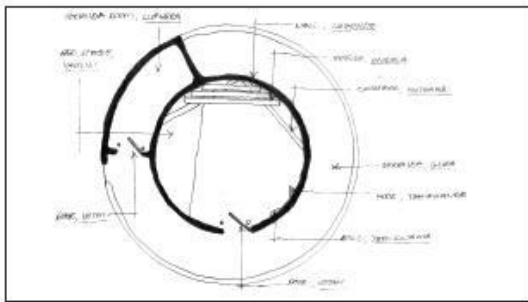

Example of a Living Hut

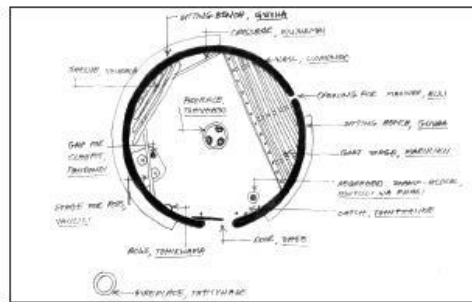

Example of a Cooking Hut

Low dividing walls between structures are either built of raw bricks or built-up with soil to a height of 1200mm and are roughly 200mm thick. These walls are similar to the veranda walls with a sitting bench, *gurha*, against the hut wall. 2 meters high timber poles planted in the soil are also used as dividing screens. The screens were called *mup funda*. The dividing walls between huts are never enclosed. There is always an opening of roughly 800mm and similar connecting openings to adjacent households. These low walls are built around sleeping-and cooking huts and stretch from hut to hut or at rights-angles to a terrace wall or dividing screens. The floor of the yard that is formed between these walls is sometimes finished with pot fragments. These were done for strengthening of the floor and decoration.

The architecture of the Venda is unique in the sense that no other tribe in the southern part of Africa uses a —front and back hierarchical demarcation of distinction. Due to the topography of the areas where Venda normally orientate their structures, the terms —front and back are synonymous to —downhill and uphill. This demarcation can be seen in the domestic unit, where the units associated with the wife or wives will be positioned downhill from those used by the father of the family. The same arrangements are observed between father and sons. The head of the family in the Venda, will have his own courtyard, kitchen and granary. Western influences in the Venda, saw the rectangular plan being adopted because of new materials and construction techniques. The Venda did not copy everything from Western culture, because they build to generate space and give them protection against the climate. The first of the structures to become westernized were the buildings of the head chief, this saw the introduction of rectangular plans and corrugated roof sheets. The Venda homestead uses a lot of timber to build. The strains that were put on the environment to keep supplying the building materials made the Venda realise the need to look for alternative building constructions. Western influences began to take a hold and eventually there was shift towards rectangular plans and building blocks.

African Indigenous green architecture can play a role in designing and achieving as bioclimatic solutions. Preference for traditional house forms, especially courtyard design (compound) architecture, which has been the predominant form of residential accommodation for both rural and urban residents in most African countries, has changed to Western villa housing designs, which now dominate large areas of African cities and towns.

The traditional multi-habited courtyard house as Andersen et al. (2006) put it is an anachronism – it is often regarded as outdated and unsuited to modern African urban life. The shift away from courtyard to villa housing in Africa is motivated by the notion of what is modern. Underlying this change is a shift in ideals, from the extended family to the nuclear family, which permeates high- and middle-income groups. This is reinforced by the standard land subdivisions and planning regulations, which favour expensive villa-style housing, and discourage the construction of indigenous compound grids with paths and lanes between houses. Indigenous compound houses, on the other hand, are relatively inexpensive to build and maintain and are affordable. Tipple (1987) revealed that one room in a compound house costs approximately one third of a room in a typical villa.

The low construction cost is due in part to the use of local building materials and simple and cheap construction techniques that are easily understood by local artisans. Courtyard houses provide safe environments for residents because the single entrance provides security by controlling who comes in and goes out. Rooms facing the courtyard provide an environment for mutual assistance and reciprocal duties of watchfulness and care in and around the courtyard and create an affirming, supportive, and safe environment. Sharing of services, which is customary and typical of courtyard houses, reduces the cost of services, making these services affordable.

Compound housing promotes high residential densities due to the large number of rooms that can be accommodated in a courtyard house. The indigenous African courtyard house is designed to make use of the elements air, light, and rain. Like the Venda, Benin's oto-eghodo and the Akan efihyia (compound houses), made extensive use of the natural elements by harnessing light, air, and water. The courtyard or the closed space in the middle of the house allowed air and light into the house, creating a humane living environment. A portion of this space is used to store harvested rainwater for use by members of the extended family. These green African designs typified McHarg's (1969) concept of —designing with nature – they were designed with nature in mind and made use of nature. The prevailing villa houses, because of their design, minimize the use of the elements to create and ensure liveable environments, but rather rely on expensive energy-consuming devices such as air conditioners, which are not affordable to a majority of urban residents in African landscape cities.

Alternative Architecture using Indigenous Green African Design Principles

This part of the paper will explore possible designs using vernacular materials. These designs "push the envelope" of what is considered standard. In these designs, vernacular materials are predominately used with some "modern materials" used in moderation for more support.

Vernacular materials which will create a unique style that is African in nature. The important point is that these materials are both green and bioclimatic in principle as well as in nature.

□ Traditional materials such as burnt brick and thatch are durable materials if used properly. Sustainable materials are used as the primary materials and modern materials are used solely as support and to enhance strength. The following design issues will then be developed.

□ Thus, the main focus is to construct houses that are beautiful and structurally correct.

Modern materials can be used to increase spans and support. The focus will be on vernacular materials and modern ones will be used modestly.

- The larger the structure, the larger the span needs to be. Increased loads are also a factor. The increased loads can be supported by modern materials.
- The detailing of these structures can be quite spectacular. Especially with connections, unique details could emerge.
- Due to increased loads and spans, the sizes of rooms can also increase, instead of having small spaces; some rooms can be quite comfortable.
- African architecture has strong ties to the land. Round structures and curvy lines have always existed because they create a sense of communal unity. Instead of a concrete block, which the trend is heading, the goal should be back to nature.

Conclusion

This paper addresses the underestimated radical but unnoticed societal shift, from experiencing the environment closely yet intuitively, to requiring a constant conscious effort to steering it while keeping a rational and physical distance. This shows a cost to the quality of life. Almost everything that has been built and used in traditional societies historically seems to have lost its lure (Heerwagen, J. 2008). Nature almost never repeats identical components that have a motorized geometry (Salingaros, N. A. 2010). Although monotonous repetition is a basic typology of post colonial design (Mehaffy, M., & Salingaros, N. A. 2011), it is not bioclimatic. This instantly shows this feature as an unnatural, hence anti-bioclimatic architecture. Is that why it is used so extensively? More recently, African architects have sought to integrate bioclimatic character into urban design again. But are the new designs truly seamless integrations of the most instinctive human geometries with natural ones? Or is this one more attempt at a kind of —green cloaking over the same failed western models of the modernist era or just another —branding by artists, of another dubious vision of the sustainable future?

Adopting and adapting African vernacular design solutions and architecture holds promise for achieving sustainable places in Africa. This paper concludes that indigenous African green design and associated architecture are sustainable in that they were compact— these cities emphasized dense, mixed, and multiple-use development. The use of walls, moats, and green buffers to control urban growth ensured continuous and orderly development, avoiding the scattered and leapfrog development found in contemporary African cities today. The courtyard architecture, which maximized urban space through mixed and multiple uses, promoted dense and compact urban forms. Farming within and around cities and the preservation of green spaces within indigenous African cities provided these cities with an aesthetically pleasing landscape, fresh food, clean air and jobs for city residents.

The mixing of uses and activities created vibrant, lively, and safe urban places. The active participation of the grass-roots (clan members, clan heads, family and chiefs) in planning and managing these cities helped in the maintenance of law and order and in the sustainability of African communities. This paper has demonstrated that there exist clear elements of socially, politically, economically, culturally, and environmentally sound and responsive planning principles to be derived from African design solutions and Bioclimatic architecture which can inform current urban planning practice and management in the contemporary urban development process in Africa today.

References

- Aluko, O. (2011). Sustainable Housing Development and Functionality of Planning Laws in Nigeria: the Case of Cosmopolitan Lagos. *Sustainable Development* 4(5), 64-74.
- Agbaje-Williams, Babatunde. "Oyo Ruins of NW Yorubaland, Nigeria." *Journal of Field Archaeology* 17, no. 3 (1990): 367-373.
- Aribigbola, A. (2008). Improving Urban Land-Use Planning and Management in Nigeria: the Case of Akure. *Theoretical and Empirical Researches in Urban Management*, 3(9), 1-14.
- Bolduc, M. (2008). *Integrated Education: A Content Analysis of State Environmental Education Plans and the EIC Model (TM)*. ProQuest.
- Brown, Z.A. (2009). Occupant comfort and engagement in green buildings: examining the effect of knowledge, feedback and workplace culture, Faculty of Graduate Studies, University of British Columbia, Vancouver, pp.1,6.
- Campbell, L. K., & Wiesen, A. (2011). *Restorative commons: creating health and well-being through urban landscapes* (Vol. 39). Government Printing Office.
- Charest, S. (2009). Ecosystem-based design: addressing the loss of biodiversity and nature experience through architecture and ecology. https://circle.ubc.ca/bitstream/handle/2429/4653/ubc_2009_spring_charest_suzanne.pdf?sequence=1 (Accessed 02-04-2013)
- Chiras, D. (2002) *The Solar House: Passive Heating and Cooling*. Chelsea Green Publishing, Vermont.
- Connah, Graham. "African City Walls: A Neglected Source?" In *Africa's Urban Past*, edited by David A. Anderson and Richard Rathbone. Oxford: James Currey, 2000.
- Cook, R., Kallianpurkar, N., Garvin, C. and Browning, B (2011). Integrating biophilic design into the built environment, Swiss Re – Centre for Global dialogue, p 2.
- Coquery-Vidrovitch, Catherine. "The Process of Urbanization in Africa (From the Origins to the Beginning of Independence)." *African Studies Review* 34, no. 1 (1991): 1-98.
- Daramola, A., & Ibem, E. O. (2010). Urban Environmental Problems in Nigeria: Implications for Sustainable Development. *Sustainable Development in Africa* 12(1), 125-145.
- Davidson, Basil. *The Lost Cities of Africa*. Little, Brown, 1959.
- Greene, Kevin (1994), *Archaeology: An Introduction*. Batsford Ltd, London
- Heerwagen, J.H. (2011). Psychosocial value of space, *Whole Building Design Guide* (WBDG), National Institute of Building Sciences, Washington DC, p. 1.
- Hosey, L. (2012). *The Shape of Green: Aesthetics, Ecology, and Design*. Island Press.
- Hull, Richard. *African Cities and Towns before the European Conquest*. New York: W. W. Norton, 1976.
- Joye, Y. (2011). A review of the presence and use of fractal geometry in architectural design. *Environment and Planning-Part B*, 38(5), 814
- Kellert, S. R. (2003). *Kinship to mastery: Biophilia in human evolution and development*. Island Press.
- Kellert, S.R. (2004). Beyond LEED: From Low Environmental Impact to Restorative Environmental Design, Keynote Address, Greening Rooftops for Sustainable Communities Conference, Sponsored by Green Roofs for Healthy Cities, Toronto, CA, and City of Portland, Portland, OR, June 4, 2004.
- Kibert, C. J. (2012). *Sustainable construction: green building design and delivery*. Wiley. http://books.google.ie/books?hl=en&lr=&id=njneo3rwzjIC&oi=fnd&pg=PR3&dq=green+roofs+that+provides+positive+biophilic+nourishment&ots=sN1cXAb-YK&sig=2nLIAjgb6aNXSD2TD3aK5KzPIA8&redir_esc=y#v=onepage&q&f=false (Accessed 03-04-2013)

- Mabogunje, A. L. *Urbanization in Nigeria*. London: University of London Press, 1968.
- Mehaffy, M., & Salingeros, N. A. (2011). Architectural myopia: designing for industry, not people. <http://www.resilience.org/stories/2011-10-09/architectural-myopia-designing-industry-not-people> (Accessed 04-04-2013)
- Millen, K. (2013). *EcoPsychology. Lecture 11 Notes*. CEM 162, MSc Architecture: Advanced Environmental and Energy Studies. *Graduate School of the Environment, Centre for Alternative Technology, Wales*.
- Miller, J. R. (2005). Biodiversity conservation and the extinction of experience. *Trends in Ecology & Evolution*, 20(8), 430-434. <http://www.sciencedirect.com/science/article/pii/S0169534705001643> (Accessed 09-04-2013)
- Nikolopoulou, M., & Steemers, K. (2003). Thermal comfort and psychological adaptation as a guide for designing urban spaces. *Energy and Buildings*, 35(1), 95-101. <http://www.sciencedirect.com/science/article/pii/S0378778802000841> (Accessed 10-04-2013)
- Oliver, Paul (2006) *Built to Meet Needs: Cultural Issues in Vernacular Architecture*, Architectural Press, Oxford.
- Salingeros, N. A. (2010). Life and the Geometry of the Environment. *Athens Dialogues E-Journal, Harvard University's Center for Hellenic Studies*. <http://permaculture.org.au/2010/10/14/life-and-the-geometry-of-the-environment/> (Accessed 02-04-2013)
- Steemers, K. (2003). Energy and the city: density, buildings and transport. *Energy and buildings*, 35(1), 3-14.
- Wald, D. M., & Hostetler, M. E. (2010). Conservation Value of Residential Open Space: Designation and Management Language of Florida's Land Development Regulations Sustainability, 2(1536-1552).
- Winters, C. (1983). "The Classification of Traditional African Cities." *Journal of Urban History* 10, no. 1: 331. Wilson, E.
- WWF.(2006).*Amazon:AbouttheRegion*. <http://www.worldwildlife.org/wildplaces/amazon/about.cfm> (Accessed 11-04-2013)

Effects of vegetation on thermal comfort in Shanghai high-density residential developments

Haiping Liu¹ and Dexuan Song²

1 Tongji University, China, liuhp523@126.com;

2 College of Architecture and Urban Planning, Tongji University, Shanghai, China, dxsong@tongji.edu.cn

Abstract

For high-density urban living environment, vegetation is a potential strategy in improving the thermal comfort of surroundings. This study chose two typical high-density residential developments in Shanghai, and conducted field experiments in different areas of two communities to evaluate the cooling effect of vegetation in different seasons during 2012-2013. In order to demonstrate the capability to cool outdoor spaces, an improved empirical model for the effect of vegetation is mainly categorized and analysed according to different variables, including presence or absence of vegetation, vegetation types and covers, seasons and times. Finally, Data results revealed that green areas are cooler, and its cooling effect is better when ambient temperature is higher, average 2-3K cooling at peak summer clear sky days. It also shows that shading is an important design factor in urban environments, since trees with high-wide crown are found more efficient than open lawns in low-shade condition.

Keywords: Cooling effect; On-site variables; Outdoor thermal comfort; vegetation design

1 Introduction

Hot weather in cities has been extensively documented (Tsiros, 2010), as research has shown the heat island effect results in warmer air, summer temperatures in urban areas makes a significant difference up to 10K between cities and suburbs (Robitu et al, 2006). It also increases energy use in summer (Yao et al, 2011), influencing outdoor space comfort and its uses. With the sustained attention, microclimate therefore becomes increasingly important for local environment. Among many variables in city microclimate, vegetation, a changeable variable, is different from other materials in humidity, aerodynamics, and thermal property (Shashua-Bar et al, 2010). As a well-known cooling strategy, vegetation is considered as the compensation of environment damage, and its influence to microclimate consequently becomes an important subject.

However, in the progress of present architectural practices, vegetation is usually treated as an element of urban design, while its ecological function is ignored (Wania et al, 2012). So the research question we concern is the influence of vegetation on the microclimate, especially thermal environment in the summertime. The aim of this work is to get powerful evidence of vegetation influence to city microclimate in Shanghai, during an extremely hot weather period in 2013, summarize potential climatic benefits, and give suggestions to future research.

Former studies provided an insight into this field. We found the climatic background of research areas relates to how important they regard vegetation is. Studies seem to concentrate

under the tropical, desert or Mediterranean climate, such as Israel, Egypt, Greece and India. Under these climates, the presence of vegetation becomes more important. In order to improve microclimate of the site, for instance, studies on Cairo (Fahmy et al, 2010) focused on how to plant trees to get the widest shade during the hot of the day.

A few studies have proved vegetation cooling effect through field measurements, and the effect may be influenced by green coverage, vegetation species, and climatic factors. R. Giridharan et al (2008) have proved when green coverage increases from 25% to 40%, air temperature would fall by 0.5K. A few studies found lawn area alone only could result in a smaller reduction in air temperature (Shashua-Bar 2009), and grass would consume amounts of irrigation. Measurements taken by Yang F et al. (2010) showed that open lawns without any shade performed even worse than pavement. After adjusting tree location, the thermal and wind environment can be improved a lot. Otherwise, conclusions of these studies are different under different climates. For example, a study of Japan found green areas only had small temperature difference with surroundings, but the cooling effect could extend several hundred meters, and more obvious during the day (De la Flor et al, 2004).

2 Methodology

2.1 Study area

Shanghai has a humid subtropical climate, hot in summer and cold in winter. The wind blows from south-east in summer and from north-west in winter. Most skies are partly cloudy. The study areas are located in the Yang pu district, a dense built-up area in Shanghai. The study chose two typical communities, Tongji new village (TNV) and Tongji green court (TGC) community, respectively multi-storey and high-rise. These two sites are located close to eliminate possible influences due to the general background conditions. Fig. 1 and Table. 1 show the measurement sites and dates.

The two communities were all built 10 years ago, and the green areas are rather dense now.

Hwang et al (2011) indicates it's not likely to represent annual thermal conditions through a particular day. Therefore, our measurements continue during the whole year of 2013, across four seasons and different weather conditions, especially focusing on summer. According to the Central Meteorological Bureau, cloud weathers accounted for majority of time, 409 days from 2011.1.1 to 2013.8.1, yet clear days only accounted for 9% of all. In the summertime of 2013, hot weathers reached the highest record in meteorology history, including 13 days over 38K in July. Given all that, except clear days with light wind less than 1.0m/s, our measurement also includes cloudy days. The values of air temperature (T_a) and relative humidity (RH), wind speed (v) were recorded in two sites.

2.2 Data measurement and observations

For the measurements, in order to increase the knowledge on the air flow and temperature characteristics of urban communities, T_a was recorded every 3 hours during the day 6:00 - 21:00. The accuracy of the thermometers is 0.1K (max) under normal meteorological conditions. Due to limited instruments and researchers, this study was based on itinerant measurements of weather parameters. For temperature measurements, each point takes nearly 1.5 minutes, and records the instrument when its digital reading becomes stable. Then, it'll take 15 minutes to record a round data every 3 hours (three workers). For a particular season and climate situation, average values of itinerant recordings would be used for analyse. Otherwise, considering wind speed is changeable, we take it as only a reference.

Many studies have proved that data from metrological station cannot actually reflect the actual microclimate condition in the city, since metrological bureaus are usually located in airports, far away from city center. Considered above, the paper uses method of L. Shashua-Bar et al. Each site chose a reference point (R), and the cooling effect due to the presence of vegetation will be evaluated by the T_a differences between R and other points. The detailed demand for R point has been stated by Shashua-Bar and M.E.H (2000). The measurement routes and points are illustrated in Fig. 2. All the values were measured at the walking level, 1.5m. The brand of thermographs is TES1361, and the brand of the wind speed anemometers is TESTO- 405-V1 (Fig. 1). The equipment was calibrated before the measurements took place.

The temperature difference will be calculated in all the occasions when at the same street and the same day. It must be pointed out that considering the complicated situation of outdoor measurements, the outdoor environment is uncontrollable, including various variables, so outdoor measurement has itself limit.



Figure 1. Plan view and pictures of measurement sites; detailed pictures of instruments

Table 1. Detailed information of measurement sites

measurment Sites	Site size	Numbers of measurement points	Numbers of measurements	Date
Road A, TNV	413*49 1m	14	700	(2012):6.25,9.30,10.1,10.2; (2013):1.1,1.10,4.3,4.10,7.10,7.24
Road B, TNV	413*49 1m	14	490	(2012):9.8,10.1,10.2; (2013):1.1,4.10,7.10,7.23
TGC	178*18 8m	7	140	(2012):12.2;(2013):1.1,7.10,7.11



Figure 2. Measurement routes and points, (a) Road A, TNV. (b) Road B, TNV. (c) TGC. (d) Central green space, TNV.

3 Discussions

Vegetation performance depends on a wide variety of greening factors, including presence or absence of vegetation, vegetation types and covers, seasons and times. In this study, several variables will be investigated. To keep reliability of results, these factors will be compared under basically consistency.

3.1 Presence or absence of vegetation

Measurement data shows street Ta decreased due to the presence of tree shade in summer. Fig. 3 analyses Road A of TNV community, lists the Ta difference between measurement points with R point. All measurement points will be divided into shade, unshaded points, and points at crossroads. Result shows shade points were cooler. The average Ta reduction of shade points was 2.7K at 15:00. For trees, leaves and branches can allow less sunlight to pass through, which can reduce Ta indirectly. In addition, results reflect no matter shadow of trees or buildings, both can cool the street. Building shade would change largely with time (Fig. 4), and since points at the crossroads (Fig.3) mainly influenced by building shadow, especially at afternoon, which may prove its influence.

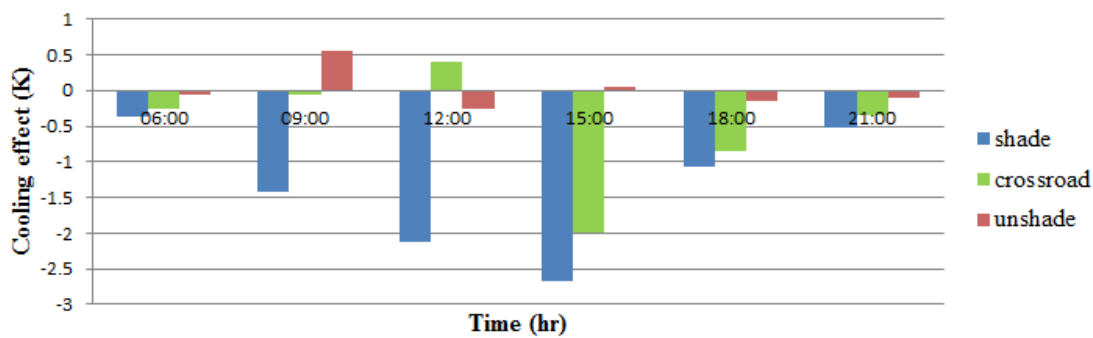

Figure 3. The cooling effect of vegetation in summer, road A, TNV (K) (Average value).

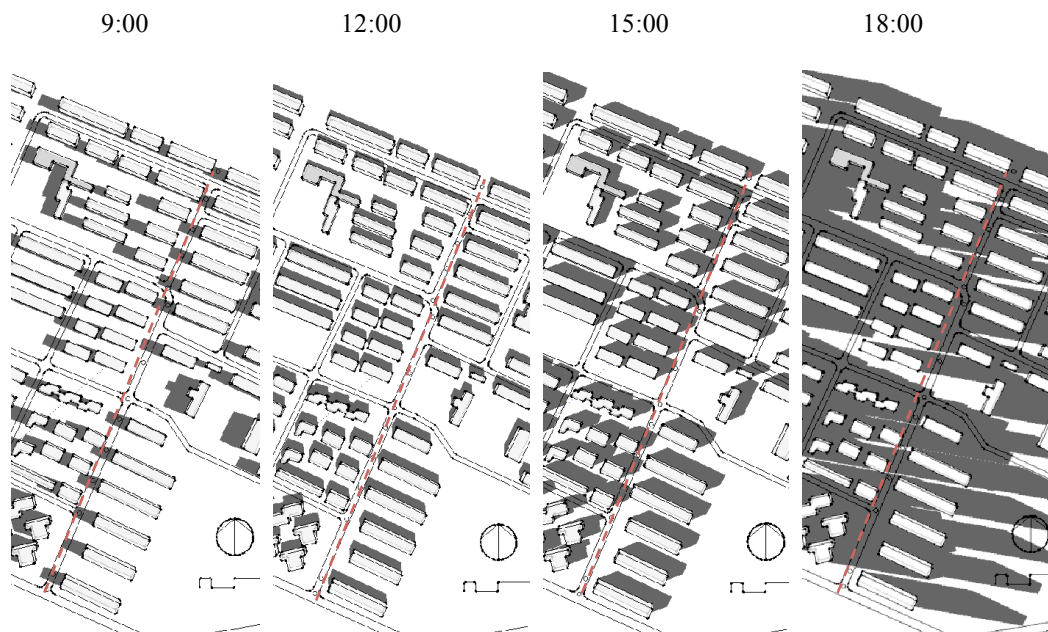

Figure 4. Building shade changing with time (Sketchup model)

3.2 Vegetation species

Compared to hard pavements, vegetation differs greatly in many properties, such as shape, albedo, evaporate and so on, so it's understandable that vegetation has a powerful influence on microclimate. In the summer measurements of the central green area (C for short), TNV, Fig. 5 shows that tree point (C5) at street level was the coolest, pavement with the highest value of 41K (C4) at 14:00, and the gap between each point and R point narrowed down after 15:00. The same changing trend of temperature showed in the high-rise community (Fig. 6), but the range of cooling effect was smaller than multi-story one, which was possibly caused by different building forms, community size, green coverage and other factors.

While the cooling effect of large un-shaded lawn is small, it should be avoided if the outdoor space is mainly used for stay or rest. Shade areas under trees with high and wide crown were cooler than open areas, but more effectively when wind can go by. C3, C5 are all points under trees, but C3 is on the wind channel with larger wind speed, 0.8K cooler than C5 (max value). So it is verified that wind is a significant factor in the reduction of T_a , because wind can quickly remove the moisture produced through vegetation evaporation, which is benefit for decreasing T_a .

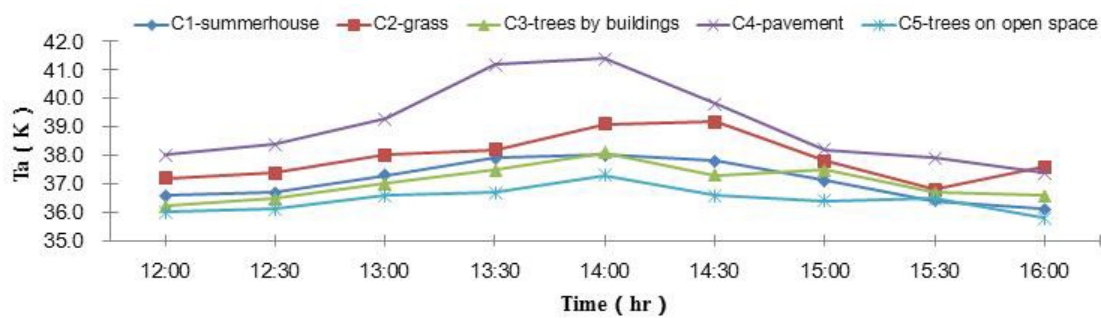

Figure 5. T_a of central green areas around time of max T_a in summer, TNV. (2013.7.10).

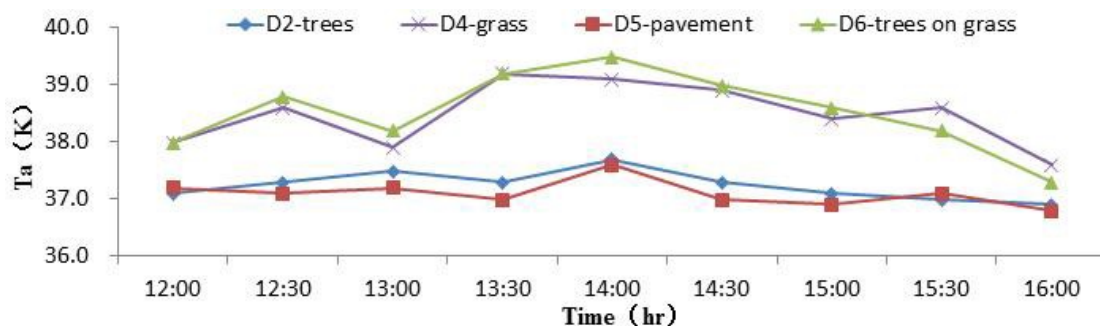

Figure 6. T_a around time of max T_a in summer, TGC. (2013.7.11).

3.3 Influence of day/season

Fig. 7 shows that the cooling effect of vegetation is most obvious at afternoon when the sun radiation is most intense, getting small at morning and late afternoon, but having no obvious influence when without solar radiation. The background temperature effects greening cooling.

Trees at the streets of TNV are deciduous. In the wintertime, trees losing their leaves allow more solar radiation, but the average cooling were still up to 1.3K (Fig. 8). However, it needs more efforts to explore if it's the contribution of vegetation only. But data at noon didn't act as expect, maybe mainly due to the strong radiation at noon and light wind. Fig. 9 shows the proportional relationship between Ta and RH. Contrary to Ta, RH reached the maximum value at early morning and then dropped down at noon.

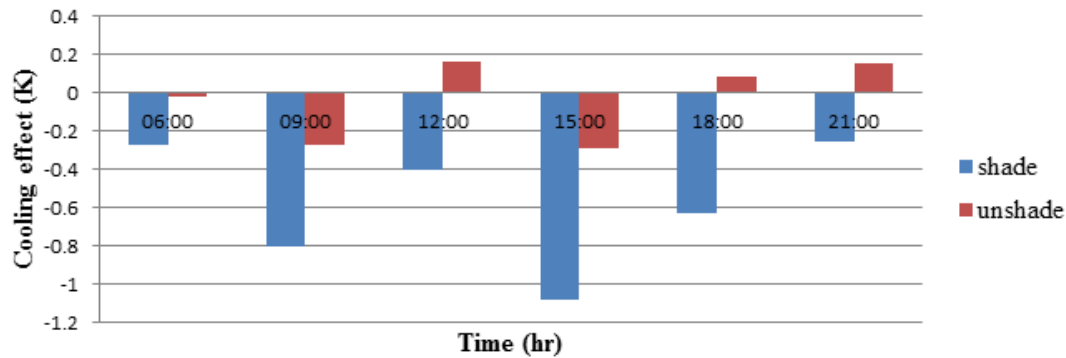

Figure 7. The cooling effect of vegetation in summer, TGC (K) (Average value).

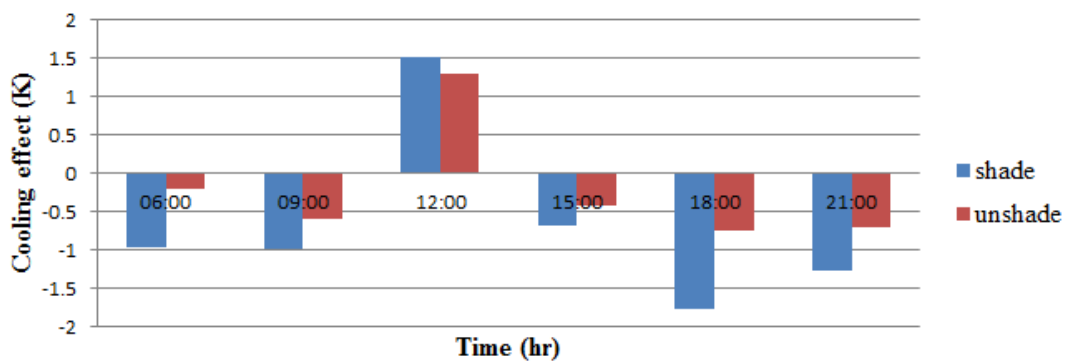

Figure 8. The cooling effect of vegetation in winter, TNV (K), 2013.1.1.

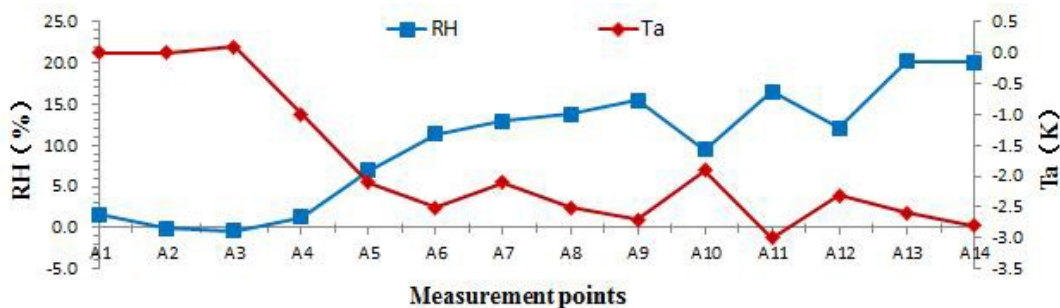

Figure 9. The relationship between Ta and RH in summer, TNV (K) (average value).

3.4 Weather condition

It was found that, with clear and calm weather, the thermal differences between shade and unshade points were higher, and the maximum and minimum T_a were 38.7K and 35.5K respectively (2013.07.24). Compared data of clear days and cloud days, it shows vegetation still had cooling effect in cloud days, with average 0.72K cooler in the day, though smaller than clear days (Fig. 10). Since direct solar radiation is less in cloudy weather, effect from tree shade turns unobvious, reduce the T_a difference between shade and un-shade areas. Unshade points A7, A10 at the crossroads were 1- 1.5K lower than ones in clear days. This conclusion agrees with Giridharan (2008)

and Shashua-Bar et al (2000), and the latter also found 80% of cooling effect of trees was contributed by its shade.

The predominant wind direction in summer is from east-south, so as the main street of the community, summer wind in this street blows to A14 from A1. From all figures of road A, TNV, we can see points located at the leeward side were cooler, such as A11 to 14, than other points at windward area, even if at cloudy weather.

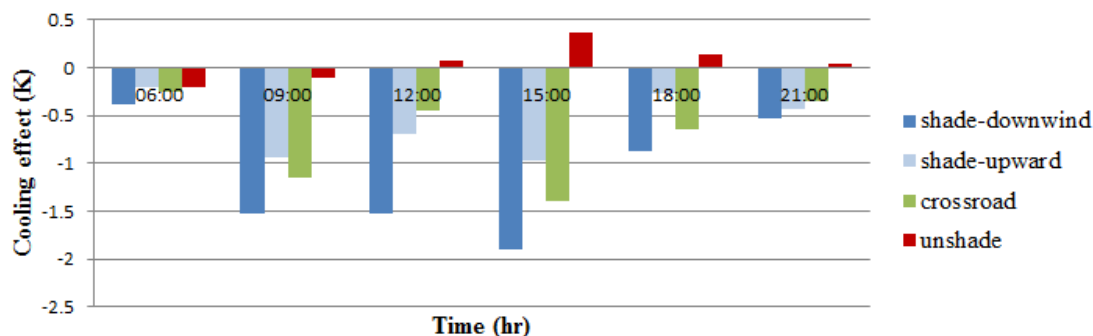

Figure 10. The cooling effect of vegetation under cloudy weather in summer, TNV (K) (2013.7.10).

4 Conclusions

In this study, we measured two typical high-density communities, including thermal environment of streets, central green areas at the walking level, and verified the cooling effect of vegetation by data comparisons and analyses. The influence of green areas is related to greening characteristics, the surrounding environment, weather conditions, and other variables. The following conclusions are obtained:

- Data shows that green areas is cooler, and its cooling effect is better when the ambient temperature is higher, average 2-3K cooling at peak summer clear sky days. The max value of cooling effect usually appeared at 15:00, when the sun radiation was strongest.
- It also shows shading is an important design factor in urban environments, since trees with high-wide crown are found more efficient than open lawns in low-shade condition.
- Trees are proved to be the most potential cooling strategy, compared to pavement, and grass.
- Vegetation also has cooling effect at winter or cloudy days, although smaller than that of summertime.
- In addition, wind is a significant element to thermal environment, and cannot be ignored when design for outdoor activities,

For the same site, the thermal environment maybe is comfortable in summer but cold in winter in the same shade condition, especially in cities with two different extreme seasons like Shanghai. So in Shanghai, community design needs to consider shade in summer, and solar heat is desirable in cool season, to build comfortable space for outdoor activities. Among these, tree coverage should be reached certain percentage to keep shade in summer, rather than simple large lawn areas, which can combine with trees. Therefore, vegetation research on microclimate should be preceded in different seasons, not just concerning the thermal parameters, but wind and light environment, which will be our future research direction.

Considering how to integrate vegetation in urban areas, the following studies will be needed, especially conducting the significance of vegetation variables, in order to effectively direct the planning and design of urban green areas, and to give appropriate suggestions for practical schemes. In the future study, computer simulation should be used to control these variables, decreasing the influence of un- correlation variables. This quantitative research will be helpful for researchers to clarify the basic knowledge of vegetation and microclimate.

References

De la Flor, F.S. and S.A. Domínguez., 2004. *Modelling microclimate in urban environments and assessing its influence on the performance of surrounding buildings*. *Energy and Buildings*, 36(5), pp. 403-413.

Fahmy, M., S. Sharples, and M. Yahiya., 2010. *LAI based trees selection for mid latitude urban developments: A microclimatic study in Cairo, Egypt*. *Building and Environment*, 45(2), pp. 345-357.

Giridharan, R., et al., 2008. *Lowering the outdoor temperature in high-rise high-density residential developments of coastal Hong Kong: The vegetation influence*. *Building and Environment*, 43(10), pp. 1583-1595.

Hwang, R.-L., T.-P. Lin, and A. Matzarakis., 2011. *Seasonal effects of urban street shading on long-term outdoor thermal comfort*. *Building and Environment*, 46(4), pp. 863-870.

Robitu, M., et al., 2006. *Modeling the influence of vegetation and water pond on urban microclimate*. *Solar Energy*, 80(4), pp. 435-447.

Shashua-Bar, L, M.E.H., 2000. *vegetation as a climatic component in the design of an urban street- An empirical model for predicting the cooling effect of urban green areas with trees*. *Energy and Buildings*, pp. 221–235.

Shashua-Bar, L., D. Pearlmutter, and E. Erell., 2009. *The cooling efficiency of urban landscape strategies in a hot dry climate*. *Landscape and Urban Planning*, 92(3-4), pp. 179-186.

Shashua-Bar, L., I.X. Tsiros. and M.E. Hoffman., 2010. *A modeling study for evaluating passive cooling scenarios in urban streets with trees*. Case study: Athens, Greece. *Building and Environment*, 45(12), pp. 2798-2807.

Tsiros, I.X., 2010. *Assessment and energy implications of street air temperature cooling by shade trees in Athens (Greece) under extremely hot weather conditions*. *Renewable Energy*, 35(8), pp. 1866-1869.

Wania, A., et al., 2012. *Analysing the influence of different street vegetation on traffic-induced particle dispersion using microscale simulations*. J Environ Manage, 94(1), pp. 91-101.

Yang, F., S.S.Y. Lau, and F. Qian., 2010. *Summertime heat island intensities in three high-rise housing quarters in inner-city Shanghai China: Building layout, density and greenery*. Building and Environment, 45(1), pp. 115-134.

Yao, R., Q. Luo, and B. Li., 2011. *A simplified mathematical model for urban microclimate simulation*. Building and Environment, 46(1), pp. 253-265.

Proceedings of 8th Windsor Conference: *Counting the Cost of Comfort in a changing world Cumberland Lodge*, Windsor, UK, 10-13 April 2014. London: Network for Comfort and Energy Use in Buildings, <http://nceub.org.uk>

Occupant time period of thermal adaption to change of outdoor air temperature in naturally ventilated buildings

Weiwei Liu^{1,2}, Pawel Wargocki², Jing Xiong³

1 School of Energy Science & Engineering, Central South University, Changsha, Hunan, China, wliu@csu.edu.cn

2 International Centre for Indoor Environment and Energy, Technical University of Denmark, Kongens Lyngby, Denmark, paw@byg.dtu.dk

3 School of Naval Architecture, Ocean & Civil Engineering, Shanghai Jiao Tong University, Shanghai, China, xiongjing@sjtu.edu.cn

Abstract

The present work proposed a method to determine time period of thermal adaption of occupants in naturally ventilated building, based on the relationship between their neutral temperatures and running mean outdoor air temperature. Based on the data of the field investigation, the subjects' time period of thermal adaption was obtained with the proposed method. The result revealed that the subjects needed to take 4.25 days to fully adapt to a step-change in outdoor air temperature. The time period of thermal adaption for the occupants in five European countries was also calculated and compared with the value of the subjects in this study. The comparison shows that the occupants in China might have a shorter time period of thermal adaption than European occupants, which means that Chinese occupants can adapt to a new outdoor climate condition faster.

Keywords: Thermal adaption; Time period; Neutral temperature; Running mean temperature

1. Introduction

Indoor thermal environment in a naturally ventilated building always changes with outdoor climate, leading to variable thermal comfort requirement of occupants (ASHRAE, 2004; EN15251, 2007). Thermal adaption has been widely accepted as the theoretical principle of thermal comfort in naturally ventilated buildings (Brager and de Dear, 1998). Time period of thermal adaption, the period of the thermal adaption process, is a key factor to occupant adaptive thermal comfort (Nicol, 2000; Nicol and Humphreys, 2002). Occupants need sufficient time to fully adapt to the change in outdoor climate conditions in order to restore thermal comfort. However, almost no existing studies were carried out to obtain the value of the time period of thermal

adaption. This study proposed a method to determine the value of time period of thermal adaption for occupants in naturally ventilated building. The method was realized based on the data of a long-term field investigation.

2. Method

2.1 Time period of thermal adaption

Time period of thermal adaption is defined as the time that occupants spent in adapting to outdoor climate change with the thermal adaption modes. Numerically, time period of thermal adaption should be determined based on human thermal comfort response after a step-change in outdoor climate condition as shown in Fig. 1. However, the actual outdoor climate condition always continuously changes within day and from day to day. The step-change in outdoor climate condition almost does not occur. Therefore it is hard to directly obtain the value of time period of thermal adaption according to the actual conditions. However, the quantitative relation between the thermal comfort response and outdoor climate condition can be established based on field investigation data under actual conditions, which provides a basis to the determination of time period of thermal adaption.

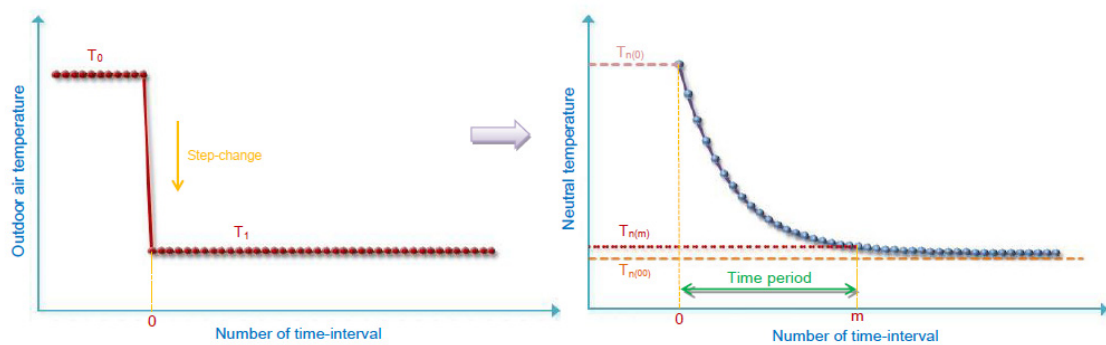

Fig. 1 Definition of time period of thermal adaption. The outdoor air temperature suddenly changed from T_0 to T_1 . $T_{n(0)}$ is the neutral temperature at the initial time “0”. $T_{n(\infty)}$ is the theoretical boundary of the neutral temperature during the thermal adaption process. $T_{n(m)}$ is the neutral temperature at the m th time-interval.

Neutral temperature is defined as the operative temperature at which an average person will be thermally neutral (ASHRAE, 2001). Neutral temperature is always used as occupants’ comfort temperature to establish adaptive comfort models and thermal comfort standards for naturally ventilated buildings (ASHRAE, 2004; EN15251, 2007). Therefore, this study selected neutral temperature as a key index to reflect human thermal comfort response in naturally ventilated buildings.

In order to get full use of survey samples, here Griffiths method was applied to calculate the value of the neutral temperature based on thermal comfort vote. The equation is given as (Griffiths, 1990),

$$T_{n-TSV} = T_{op} - TSV / G \quad (1)$$

where T_{n-TSV} is the neutral temperature according to thermal sensation votes from field investigation, T_{op} is the operative temperature calculated based on the measured air temperature and mean radiant temperature, TSV is the thermal sensation vote of occupants and G Griffiths coefficient.

The existing studies indicated that occupant neutral temperature is associated with his thermal history with more recent experiences being more influential (Nicol and Humphreys, 2010). Therefore, the exponentially – weighted running mean outdoor temperature was adopted to reflect the significant role of the past and current thermal experiences with outdoor climate condition, which had been applied as the basis of the adaptive thermal comfort model for free-running buildings in European standards EN15251 (Nicol and Humphreys, 2010).

The equation for the running mean outdoor temperature is (Nicol and Humphreys, 2010)

$$T_{rm} = (1 - \alpha) \{T_{t-1} + \alpha T_{t-2} + \alpha^2 T_{t-3} \dots\} \quad (2)$$

where T_{rm} is the running mean outdoor temperature at time t , T_{t-n} the instantaneous outdoor air temperature (the mean for equal time interval - hours, days, etc.) at n time-intervals previously. α can be seen as a time constant ($0 \leq \alpha < 1$) that quantitatively reflects the rate at which the effect of any past temperature decays. The bigger the value of α the greater is the effect of past temperature.

According to equation (2), the time series gives a running mean outdoor temperature that is decreasingly affected by past outdoor temperatures as time passes. Therefore, the running mean outdoor temperature can reflect the time-dependence of the adaptive thermal comfort on the outdoor air temperature experienced, by establishing the relationship between the neutral temperature and running mean outdoor temperature.

The quantitative relationship between running mean outdoor temperature and occupant neutral temperature was developed as,

$$T_n = aT_{rm} + b \quad (3)$$

where T_n is neutral temperature, a the variation rate of neutral temperature with running mean outdoor temperature and b a constant.

As illustrated in Fig. 1, the value of time period of thermal adaption was calculated as the time span that the neutral temperature reaches a new steady value after a step-change in outdoor climate condition. Using equation (3), the trend of the neutral temperature after a step-change in outdoor air temperature can be obtained.

Based on equations (2) and (3), the time period of thermal adaption can be obtained as the following equation (see Appendix),

$$TP = \text{round} \left[\frac{\ln(1-r)}{\ln(\alpha)} \right] \times \Delta d \quad (4)$$

where the function $\text{round}[\text{data}]$ means the data in the square brackets is rounded up. TP is the time period (day) of thermal adaption and r is a ratio reflecting the degree that the neutral temperature at the final time-interval is close to its limit value during

the adaption process. α is the time constant and Δt is the time-interval in equation (2).

In all, the method to estimate the time period of thermal adaption can be simply described by Fig. 2.

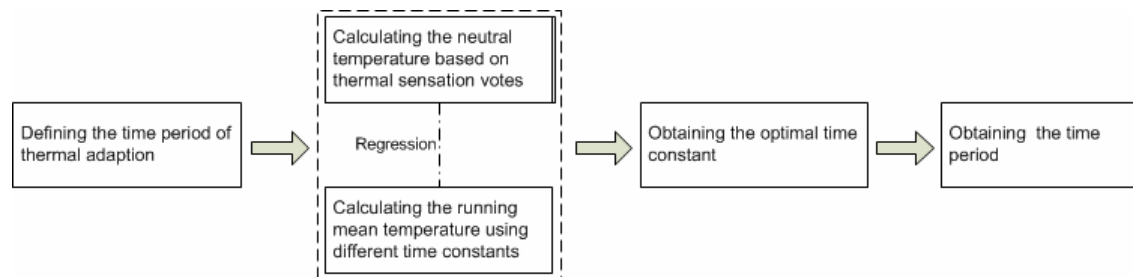

Fig. 2 The method to estimate the time period of thermal adaption

2.2 A longitudinal survey

A longitudinal survey provided field data for the present study, which was carried out in two typical offices located in different types of naturally ventilated buildings.

2.2.1 Location

The two naturally ventilated office buildings for the field investigation were located in Central South University, Changsha, China, with a climate of hot summer and cold winter. As shown in Fig.3(a), building A, a four-story building, houses offices for teachers and graduated students on two floors (the second and third floor), and building B, a courtyard house, hosts offices just for graduated students.

In each building, one office was selected for the survey (see Fig. 3(b)). Each office can accommodate 4~8 occupants, which was very common in universities of China. Office A, a west-facing room on the third floor of building A, has an area of 40 m² (7.7x5.2 m) and a height of 3 m. Office B is a south-facing room in building B with an area of 43.2 m² (7.2x6 m) and a height of 4.5 m. It can be seen in Fig. 3(b) that there are operable windows and doors in both offices. A floor-standing air conditioner (cooling and heating) is equipped in each office, which were only used in hot (summer) and cold (winter) weather. Different from office A, there are four wall fans and two ceiling fans in office B, which also provided a cooling strategy in hot weather.



(a) Buildings A (left) and B (right)



(b) Offices A (left) and B (right)

Fig. 3 The naturally ventilated offices for the long-term survey

2.2.2 Subjects

All subjects in both offices are healthy graduated students, including 9 males and 6 females (mean \pm SEM of age: 23.9 ± 0.6 years, height: 168.6 ± 2.1 cm, weight: 59.9 ± 2.6 kg). They mainly carried out office related work, such as reading, writing and typing in a computer. Every student has lived in the university for more than one year and acclimatizes themselves to the climate in Changsha. All of them participated as subjects in the long-term survey. All protocols were approved by the university's ethics committee and conformed to the guidelines contained within the Declaration of Helsinki. Verbal and written informed consent was obtained from each subject prior to the participation in the survey.

During the period of survey, there were 4~6 students in Office A and 6~8 students in office B. Among these students, three graduated from the university in May 2010 and one left the office in Sep. 2010, while two joined in Oct. 2010.

2.2.3 Instrumentation

Four important indoor thermal environment parameters were monitored. Air velocity, temperature and relative humidity were collected using a multifunctional heat line anemoscope (TSI 9545-A VELOCICALC, TSI Incorporated, USA). Globe temperature was measured with a standard black-bulb (D 150mm, KIMO, FR). The precision of each instrument is listed in Table 1.

Table 1 Instruments for the measurement of indoor thermal environment parameters

Parameter	Instrument	Range	Accuracy	Resolution
Globe temperature	Digital thermometer TR102	-100 ~ 400 °C	±0.3 °C	0.1 °C
Air temperature	Velocicalc TSI-9545	-10 ~ 60 °C	±0.3 °C	0.1 °C
Air velocity	Velocicalc TSI-9545	0 ~ 30 m/s	±3%	0.01 m/s
Relative humidity	Velocicalc TSI-9545	0 ~ 95%	±3%	0.10%

The indoor environmental parameter measurement site was located near each subject at 1.1 m height, as displayed in Fig. 2(b). The location of each subject was more than 2.0 m away from the doors, windows and fans.

2.2.4 Protocol

The survey was conducted daily from Jan. 2010 to Feb. 2011, except for some holidays such as some days during summer and winter vacations (Jul.-Aug. and Jan.-Feb.). Every day, the researchers carried out the survey three times (morning/afternoon/night) at most. The periods for the survey in morning, afternoon and night were respectively 10:30-11:30, 16:00-17:00 and 20:00-21:00. The survey was done on the subjects being in the offices for at least 20 minutes.

During a single survey, each subject in both offices was asked to fill out the electronic questionnaire reflecting their subjective responses, clothing, and activity level in the preceding 20 minutes. At the same time, the thermal environment close to each subject was continuously monitored for 5 minutes. Subjects' controls on window, door, curtain, fan and air-conditioner were carefully recorded by the same researcher. The time of each investigation spent in each office was about 30 minutes.

2.2.5 Questionnaire

A questionnaire was designed to provide the following main information:

- (1) Subjective thermal responses, including thermal sensation, thermal acceptability and thermal preference. In this study, only the response of thermal sensation was analyzed, which was evaluated using the ASHARE 7-points continuous scale from -3 (cold) to +3 (hot).
- (2) Current clothing level. The subjects were asked to record the combination of their clothing in order from underwear to outerwear. A fairly detailed clothing garment list was provided for reference. According to the records of subjects' clothing in the survey, ensemble clothing insulation (CLO) was estimated based on procedures in ASHRAE Standard 55 (ASHRAE, 2004).
- (3) Activity level in the preceding 20 minutes. This item asked the subjects to describe the primary activity during the last 20 minutes in the offices.

The questionnaire was written in Chinese. The subjects completed the questionnaire on their computers in 5 minutes.

2.3 Meteorological data

Meteorological data for the period of the longitudinal survey were obtained from a local station near the university. The data contains outdoor air temperature, humidity and wind speed. They were recorded on an hourly basis. The data of the hourly outdoor air temperature was used to calculate the running mean outdoor temperature in this study.

2.4 Statistical analysis

Linear regression method was applied to establish the relation between running mean outdoor temperature and occupant neutral temperature based on the filed survey data. To evaluate a linear regression equation, determination coefficient R^2 was used to indicate the goodness of fit and the level of significance was set at $p < 0.05$.

3. Results

3.1 The variation in the observed neutral temperature over different periods

As shown in equation (2), the running mean outdoor temperature is calculated based on the mean outdoor air temperature over each time-interval. For each time-interval, occupant neutral temperature was assumed as a steady value. In order to determine an appropriate time interval for the calculation of running mean outdoor temperature, it is necessary to investigate the variation in occupant neutral temperature over different periods (day/ week/ month/ season) during the field survey.

Two indexes, standard deviation (S.D.) and range (the difference between maximum and minimum), were used to reflect the variation in the values of the neutral temperature during each period. As shown in Fig. 4, the mean S.D. and range of the observed neutral temperature (corresponding to the thermal sensation vote of “neutral” in the survey) raised with the increase in period (from day to season). For the period of a day, both the mean S.D. and range of the observed neutral temperature had the smallest values (about 1 °C). According to the trend, the variation in occupant neutral temperature should be smaller than 1 °C in a period less than a day.

Therefore, 6 hours (1/4 day) was selected as the time-interval to calculate the running mean outdoor temperature in this study, considering the time to conduct a single survey (see section 2.2.4). The 1/4 day time-intervals were separately: 7:00 ~ 12:00, 13:00 ~ 18:00, 19:00 ~ 24:00 and 1:00 ~ 6:00 in each day.

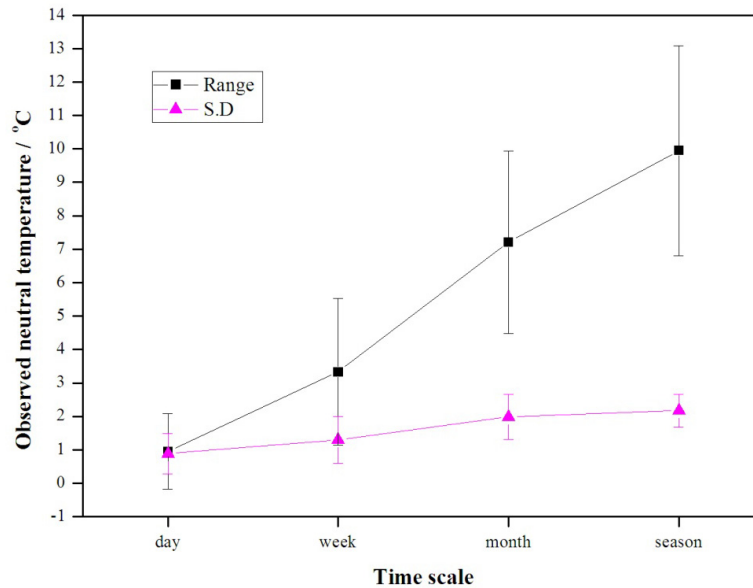

Fig. 4 The variation in the observed neutral temperature of occupants over different periods

3.2 The optimal time constant α for the running mean outdoor temperature

As depicted in section 2.1, it is important to find the optimal value of the time constant α in equation (2) when calculating the running mean outdoor temperature. The optimal value of α should be related to the adaptive thermal comfort response and can reflect the highest correlation of occupant neutral temperature with the running mean outdoor temperature.

Here, the running mean outdoor temperature was calculated from the mean outdoor air temperature over the time-interval of 1/4 day using a range of values of α . The running mean outdoor temperature was then correlated with the neutral temperature T_{n-TSV} . The values of the correlation coefficient c were obtained with different values of α , which provided a basis for the determination of the optimal value of α .

For the neutral temperature T_{n-TSV} , the value of c rose to a maximum (0.939) at a value of α of 0.841. Therefore, 0.841 can be used as the optimal value of α to calculate the running mean outdoor temperature.

3.3 Time period of thermal adaption due to different thermal adaption modes

Based on the data of the longitudinal survey, the quantitative relationship between the neutral temperature and running mean outdoor temperature was developed as,

$$T_{n-TSV} = 0.598 \times T_{rm} + 11.7 \quad (\alpha = 0.841, R^2 = 0.882, p < 0.001) \quad (5)$$

According to equation (4), the time period of thermal adaption was calculated using the values of α and time-interval. The value of r in equation (4) was set as 0.95. As referred before, the time-interval was 6 hours (1/4 day). The calculation was shown as follows.

$$TP = \text{round}\left[\frac{\ln(1-0.95)}{\ln(0.841)}\right] \times \frac{1}{4} = 17 \times \frac{1}{4} = 4.25 \text{ day}$$

The result means that occupants need to take about four days to fully adapt to a step-change in outdoor air temperature.

4. Discussion

It is interesting to compare the time period of thermal adaption of Chinese with those of occupants in other countries. Based on the best values of the time constant α for the occupants in five European countries (McCartney and Nicol, 2002), the time period of thermal adaption was calculated with equation (4) (the value of r was set as 0.95) and compared with the result given by this study. The comparison was listed in Table 2.

Table 2 Comparison of the time period of thermal adaption between the occupants in European countries and those in China

Country	The best time constant	Time-interval	Calculation of neutral temperature	Time period of thermal adaption	Type of survey data
France	0.70	1 day	Griffiths method	8 days	Longitudinal
Greece	0.94	1 day	Griffiths method	48 days	Longitudinal
Portugal	0.80	1 day	Griffiths method	13 days	Longitudinal
Sweden	0.33	1 day	Griffiths method	3 days	Longitudinal
UK	0.45	1 day	Griffiths method	4 days	Longitudinal
All	0.80	1 day	Griffiths method	13 days	Longitudinal
China	0.944	1/4 day	Griffiths method	4.25 days	Longitudinal

Among the five European countries, the time period of thermal adaption of the occupants in Greece was much longer than those in the other countries, while the occupants in Sweden took the least days to fully adapt to the change of the outdoor climate condition. The value of the time period of thermal adaption for the occupants in China was slightly bigger (1/4 day) than that in UK. However, obvious difference can be found in the time period of thermal adaption between China and the other four European countries. If the data from five European countries was combined (see "All" in Table 2), the occupants in China had a shorter time period of thermal adaption than European occupants, which indicated that the Chinese occupants can adapt to a new outdoor climate condition faster. The main reason to the difference might be the distinct behavioral adjustment (the physical adaption) (Liu et al, 2012) and expectation of the occupants (the psychological adaption) (Liu et al, 2013) caused by the totally different climate conditions in European countries and China. However,

considering that the field data were obtained from several countries in Europe and one city in China, the result of this comparison needs to be validated by adequate field investigation conducted in more cities and countries.

The result of this study was obtained based on the long-term investigation conducted in the buildings where the air-conditioner could be used (Liu et al, 2012). For the naturally ventilated buildings without air-conditioners, the time period may be different. However, the proposed method can be applied for any naturally ventilated building based on the data of field investigation.

5. Conclusion

Main conclusions were obtained as follows.

- (1) The time period of thermal adaption can be determined based on the relationship between the neutral temperature and running mean outdoor temperature.
- (2) The occupants need to take 4.25 days to fully adapt to a step-change in outdoor air temperature.
- (3) The occupants in China might have a shorter time period of thermal adaption than the occupants in the European countries.

Acknowledgements

The project was financially supported by the National Natural Science Foundation of China (No. 51208512). The authors would like to acknowledge the subjects who volunteered for the long-term survey.

Appendix. Determination of time period of thermal adaption

Suppose that the outdoor air temperature kept at a start value of T_0 before a step-change and suddenly changed to a value of T_1 at an initial time “0” (see Fig. 1), as described by the following equation,

$$T_0 = T_1 + \Delta T \quad (6)$$

where ΔT is the variation in the outdoor air temperature.

According to equation (3), the neutral temperature at the i th time-interval after the step-change of the outdoor air temperature was given as,

$$T_{n(i)} = aT_{rm(i)} + b \quad (7)$$

where $T_{n(i)}$ and $T_{rm(i)}$ are the neutral temperature and running mean outdoor temperature at the time-interval i , respectively.

The running mean outdoor temperature at the i th time-interval can be calculated using the value of the running mean and of the mean outdoor temperature for the previous time-interval (Nicol and Humphreys, 2010).

$$T_{rm(i)} = (1 - \alpha)T_{i-1} + \alpha T_{rm(i-1)} \quad (8)$$

where T_{i-1} and $T_{rm(i-1)}$ are the mean and running mean outdoor temperature at the time-interval $(i-1)$, respectively.

At the initial time (0), the running mean outdoor temperature ($T_{rm(0)}$) was equal to the start temperature T_0 . Accordingly, the neutral temperature ($T_{n(0)}$) was calculated with equation (7).

$$T_{n(0)} = aT_0 + b \quad (9)$$

The neutral temperature at the i th time-interval ($i > 0$) can be obtained by substituting equation (8) into equation (7).

$$T_{n(i)} = a[(1 - \alpha)T_{i-1} + \alpha T_{rm(i-1)}] + b \quad (10)$$

Equation (10) can be extended as,

$$\begin{aligned} T_{n(i)} &= a[(1 - \alpha)(T_1 + \alpha T_1 + \alpha^2 T_1 + \dots + \alpha^{i-1} T_1) + \alpha^i T_{rm(0)}] + b \\ &= a[(1 - \alpha)T_1(1 + \alpha + \alpha^2 + \dots + \alpha^{i-1}) + \alpha^i T_0] + b \\ &= a[(1 - \alpha)T_1 \frac{1 - \alpha^i}{1 - \alpha} + \alpha^i T_0] + b \\ &= a[T_1 + \alpha^i \Delta T] + b \end{aligned} \quad (11)$$

Further, the theoretical boundary of the neutral temperature ($T_{n(\infty)}$) can be gotten with equation (11),

$$\begin{aligned} T_{n(\infty)} &= \lim_{i \rightarrow \infty} [a[T_1 + \alpha^i \Delta T] + b] \\ &= aT_1 + b \end{aligned} \quad (12)$$

After the step change of the outdoor air temperature, the neutral temperature gradually tends to the theoretical boundary. Here, a ratio r was defined as follows.

$$\begin{aligned} r &= \frac{T_{n(i)} - T_{n(0)}}{T_{n(\infty)} - T_{n(0)}} \\ &= \frac{a(\alpha^i - 1)\Delta T}{-a\Delta T} \\ &= 1 - \alpha^i \end{aligned} \quad (13)$$

The value of r ($0 < r < 1$) can reflect the degree that the neutral temperature ($T_{n(i)}$) is close to the limit value ($T_{n(\infty)}$) during the process of change. Giving r a value close to 1, the corresponding value of the neutral temperature ($T_{n(m)}$) was regarded as the new steady value after the step-change of the outdoor air temperature. The corresponding number (m) of time-intervals was calculated according to equation (13).

$$m = \text{round} \left[\frac{\ln(1-r)}{\ln \alpha} \right] \quad (14)$$

where *round* [data] means that the data in the square brackets is rounded up.

The time period of thermal adaption (TP) was obtained on the basis of equation (14), according to its definition as mentioned in section 2.1.

$$\begin{aligned}
 TP &= m \times \Delta d \\
 &= \text{round} \left[\frac{\ln(1-r)}{\ln \alpha} \right] \times \Delta d
 \end{aligned}
 \tag{15}$$

where Δd is the value of the time-interval.

References

ASHRAE, 2001. Thermal comfort. ASHRAE Handbook: Fundamentals. Atlanta: American Society of Heating, Refrigerating and Air-Conditioning Engineers, Inc.

ASHRAE, 2004. Thermal environmental conditions for human occupancy. Standard 55-2004. Atlanta: ASHRAE.

Brager GS, de Dear RJ., 1998. Thermal adaption in the built environment: a literature review. *Energy and Buildings*, 27(1), pp 83-96.

CEN Standard EN15251, 2007. Indoor environmental input parameters for design and assessment of energy performance of buildings- addressing indoor air quality, thermal environment, lighting and acoustics. Brussels: Comite Europeen de Normalisation.

Griffiths I, 1990. Thermal comfort studies in buildings with passive solar features: field studies, Report to Commission of the European Community, ENS35 909, UK.

Liu W, Zheng Y, Deng Q, Yang L, 2012. Human thermal adaptive behaviour in naturally ventilated offices for different outdoor air temperatures: A case study in Changsha China. *Building and Environment*, 50(4), pp 76-89.

Liu W, Deng Q, Ma W, Huangfu H, Zhao J, 2013. Feedback from human adaptive behavior to neutral temperature in naturally ventilated buildings: physical and psychological paths. *Building and Environment*, 67, pp 240-249.

McCartney KJ, Nicol JF, 2002. Developing an adaptive control algorithm for Europe. *Energy and Buildings*, 34(6), pp 623-635.

Nicol JF, 2000. Time and thermal comfort: evidence from the field. *World Renewable Energy Congress VI (WREC2000)*, pp 477-482.

Nicol JF, Humphreys MA, 2002. Adaptive thermal comfort and sustainable thermal standards for buildings. *Energy and Buildings*, 34(6), pp 563-572.

Nicol JF, Humphreys MA, 2010. Derivation of the adaptive equations for thermal comfort in free-running buildings in European standard EN15251. *Building and Environment*, 45(1), pp 11-17.

Proceedings of 8th Windsor Conference: *Counting the Cost of Comfort in a changing world*
Cumberland Lodge, Windsor, UK, 10-13 April 2014. London: Network for Comfort and
Energy Use in Buildings, <http://nceub.org.uk>

Lifecycle Costing of Low Energy Housing Refurbishment: A case study of a 7 year retrofit in Chester Road, London

Theodora Neroutsou¹

1 University College London, UK, t.neroutsou.12@ucl.ac.uk

Abstract

The low energy retrofit of the UK existing building stock is an urgent matter after the government's commitment to reduce carbon emissions by 80% until 2050. This research addressed the question of whether it is preferable to refurbish in an extensive way or to choose a retrofit strategy with lower capital cost, embodied energy and CO₂, tackling issues of cost – effectiveness, embodied and operational energy throughout the lifecycle of an existing Victorian house in London.

The indicator Cost per Ton carbon Saved (CTS) was used, which resulted in higher values for the EnerPHit retrofit model, rendering it a less viable alternative. It was also concluded that retrofitting, in general and especially the application of EnerPHit, are an appealing option only with rising gas prices, low discount rates and long lifespans. Those results were even more amplified when climate change was taken into account, a conclusion very important for the application of future legislation and the possible transfer of this study to other climates.

It was deduced that a house's remaining lifetime is a very significant factor to be taken into account, as investments of higher capital cost give higher benefit in long term.

Keywords: Retrofit, Cost per Ton carbon Saved (CTS), EnerPHit, Lifecycle Analysis

1. Introduction

Dwellings account for 60 % of EU building energy use, 40 - 60 % of which is energy used for heating with 80% of the existing building stock proven to exist in 2050 (Thorpe, 2010). With the Climate Change Act (HMSO, 2008) low carbon retrofitting of this stock becomes a necessity for the UK, as it sets targets of 80% reduction in net carbon account emissions by 2050 and 34% by 2020 with a baseline of 1990. This policy is mainly driven by two key driving forces: climate change and energy security.

1.1 Energy consumption in UK domestic buildings

The majority of energy consumed in the domestic sector is for space heating, producing in 2009 25 % of the total CO₂ emissions (HMSO, 2011). Water heating and lighting and appliances accounted for a further 18 and 19 % respectively with cooking accounting for a further 3 % (DECC, 2012).

As resulting from the above, in the context of climate change, fossil fuel insecurity and the attribution of the second biggest percentage of energy consumption to domestic buildings it is essential to prioritize the minimization of energy in the domestic stock in the way towards an 80% reduction in CO2 emissions by 2050. With heating making up the biggest part of the consumption, increasing the insulation levels and the heating systems' efficiency in the existing building stock is expected to cause a big improvement.

1.2 Aims and hypothesis

Aim of this study is to address the topic of sustainable refurbishment of the existing building stock, by tackling the issues of cost – effectiveness, embodied and operational energy throughout the lifecycle of a residential building. This is researched by the comparison of a case study refurbishment complying with Part L1 B and a hypothetical refurbishment complying with PH standards, under the prism of Cost per Ton carbon Saved. The effect of individual measures and the optimization of insulation levels throughout the buildings' lifetime will be assessed under the same perspective.

Thus, this study will address the debate of whether it is preferable to refurbish in an extensive way (insulating as much as possible), in order to achieve the minimum operational energy or to choose a retrofit strategy with lower capital cost, embodied energy and CO2, which hypothetically will be paid back earlier.

2. Literature review

2.1 Life Cycle Costing and Low Energy Retrofit

In order to assess the optimum retrofit strategy for existing buildings, LCC was used in numerous studies, underlying the importance of considering the building as an energy system throughout its lifetime.

LCC is the total cost of a building or its parts throughout its life, including the costs of Acquisition (including pre-construction and construction), Operation, Maintenance, Replacement (or refurbishment) and Disposal (sale or demolition) (ISO, 2003). It is a technique which enables comparative cost assessments to be made over a specified period of time, taking into account all relevant economic factors both in terms of initial capital and future operational costs. In particular, it is an economic assessment considering all projected relevant cost flows over a period of analysis expressed in monetary value (ISO, 2003).

Retrofitting aims to the minimization of operational energy, however, focusing solely on the operation phase may bring less overall benefits due to potential trade-offs in other life cycle phases. According to a study (Feist, 1997) comparing the cumulative primary energy input over a lifetime of 80 years of six construction standards, the total production energy input for the passive house is 1391 kWh/m², with thermal insulation measures accounting for 14 % (194 kWh/m²). The study claims that thermal insulation and ventilation saved 123 kWh/(m²a) on primary energy, having, thus, less than two years payback time. In the Life-Cycle primary energy balance for the 'reference', LE, PH and self sufficient house, it is obvious that the latter is always above the passive one, while the starting points for the five first types are very close, contradicting the argument that PH has a significantly bigger initial energy input compared to standard buildings.

The 'Arbeitskreis Kostengünstige Passivhäuser, 1997' (Research Group on Cost Efficient Passive Houses) (Passipedia) concluded that the condition of the building prior refurbishment strongly determines whether an energy saving measure can be considered economical or not. It was also claimed that the implied extra investment of a PH retrofit leads to an overall gain during the lifetime of the components, with careful planning and implementation processes. Most importantly, it was inferred that the highest levels of thermal protection measures available are also the optimum ones, in terms of cost-effectiveness, based on the 'do it as good as possible' principle.

A study comparing the retrofit of a 1950 Belgian dwelling to common practice, LE and PH standard (not EnerPHit standard) concluded that, although the PH retrofit saves on 87 % on heating demand, in contrast to 63 % of the LE one, its initial cost's payback period is highly dependent on fuel price increase. With 2 % increase the PH is not paid back not even in 40 years, making LE more cost effective, while with the improbable 10 % fuel price increase, the payback time is 18.4 years (Versele A., 2008).

On the other hand, Hermelink (2009) compared an existing PH development to a fictitious LE alternative based on environmental life cycle assessment, assuming constant gas prices. He found that construction and maintenance/repair have a relatively high environmental impact, exceeding the impact of space heating. Moreover, it was

concluded that the slightly higher environmental impact of PH building stemming from construction and maintenance/repair is clearly over-compensated by its significantly lower operational energy consumption. While assessing the CO₂ emissions of the two LE building types, it was found that the LE would fail the 2050 target and the PH hardly reaches it, mainly due to the carbon intensity of electricity generation. From the cost point of view, as well, PH appears to be the most attractive solution, especially with increased gas and electricity prices.

Dodoo et al. (2010) and Gustafsson and Karlsson (1988) highlight the importance of the type of energy supply system which is substituted by the retrofit, concluding that the un insulated building with district heating has lower life cycle primary energy use than if the same building was retrofitted to the PH standard and heated electrically. Similarly to Feist (1997), a 4 year payback period of the primary energy for building construction through the operational energy savings was assessed.

The payback period of an energy retrofit is highly dependent on fuel prices and weather data and, as resulted from the WLCC study of Mohammadpourkarbasi (2013) of a refurbished Victorian house under three gas prices and three weather scenarios, such an investment is only economically attractive with the rising gas prices scenario, although the additional costs of maintenance and replacement of the base case house were not taken into account, which is expected to alter the results. Interestingly, the cumulative cash flow of the refurbished near to PH standard building shows that the payback time from heating saved will be 27 years with upward prices and may never realistically pay back if prices fall or remain constant.

It is important to stress, however, the importance of the boundary condition of each study in the validity of the results. Fuel prices, construction costs, risk rates and climatic conditions affect significantly the outcome of the cost assessment.

3. Methodology

3.1 Case Study Selection

An existing house has been selected as the case study for the investigation of the optimum retrofit of Victorian end terrace buildings. It is located at 73 Chester Road, Dartmouth Park, London.



3.1.1 The house

The case study house is a Victorian semi – detached end terrace house built before 1919. It is formed by two volumes, a three - storey one in the front, facing North West, and a two - storey extension in the rear and is currently used by its two owners (Figure 1).

The total usable floor area is approximately 167 m². The ground floor consists of the hall, two living room areas connected with each other and the kitchen in the rear extension (Figure 2). The staircase in the hall leads to the first floor's hall which distributes to a front bedroom, used as an office, a rear bedroom, an office and to the bathroom and utility space. The staircase continues to the attic floor, consisting of a guest room and a WC.

Figure 1 Front Elevation

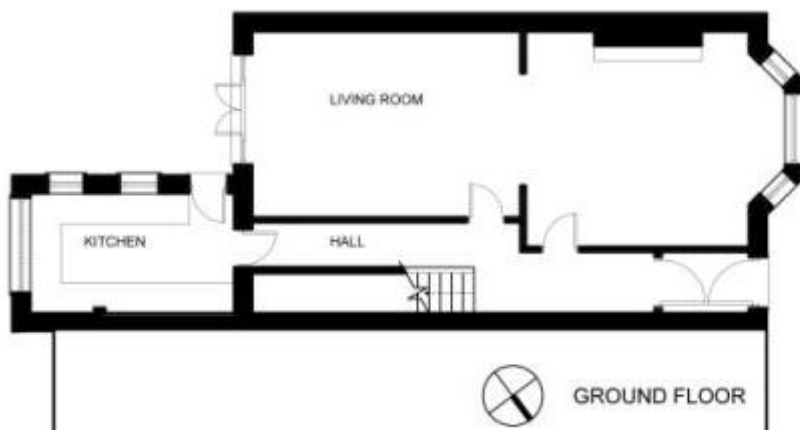

Figure 2 Ground Floor Plan, not in scale

3.2 The retrofit

3.2.1 Building Envelope

Table 1 Refurbishment of building envelope

Element	Refurbishment description
Walls	Double brickwork 220mm Internal insulation with 100mm Diffutherm woodfibre boards ($U=0.043\text{W/m}^2\text{K}$)
	50mm insulation installed in the kitchen, the bathroom and around the fireplace
Party wall	Kitchen: partly insulated (130 cm from the junction with the external wall) Bathroom: insulated for the whole length Hall: above the height of 7m
Side wall	Re-pointed with a cement mortar with moisture resistance
Roof	100mm rockwool installed between the rafters, two layers of Diffutherm (40mm) and 22mm of Isolair ($U=0.047\text{W/m}^2\text{K}$) above)
Floors	Living room: Suspended floor retained, floor boards replaced and the old ones used in the attic. Intermediate space between the joists filled with rockwool (150 mm) and 20mm of Diffutherm added below them. Junctions with walls foamed
	Hall: tiled Victorian floor not altered
	Kitchen: solid floor insulated with 50mm XPS
	Attic floor: insulated mainly for noise proof issues with 100mm rockwool between the joists, Regupol acoustic isolating strips on joists and chipboard on top
Windows and doors	Original sash windows at the front: now argon-filled double glazing manufactured by Vogrum
	Rear living room French door: triple glazed Ecocontract ($U=0.9\text{W/m}^2\text{K}$).
	Kitchen, bathroom and attic: Rationel double ($U=2.1\text{W/m}^2\text{K}$)
	First floor windows: double glazed
	Skylights: Velux Conservation ($U=1.7\text{W/m}^2\text{K}$)
	Windows and doors: draught – sealed
	Second door added to the entrance space, creating a draught lobby

3.3 Whole Life Cycle Costing

One of the most important questions in the process of achieving 80 % reduction of CO₂ is economic feasibility. As cost is a determining factor both for individual and governmental initiatives, the importance of finding the most economical choice among alternative refurbishment levels and measures in long term is vital. In this study a LCC

technique has been used for comparative cost assessments initially over a 30 year lifespan, taking into account the present value of initial capital costs, future operational costs and savings from the two different retrofit approaches.

3.3.1 Embodied Energy Inputs

The Inventory of Carbon and Energy (Hammond and Jones, 2008) was used for the calculation of the EE and ECO₂ of the materials used for the refurbishment of the building envelope. For the calculation of the window's frames', the data were obtained from the Ökobilanzdaten im Baubereich database of the Swiss Coordination of Construction and Property Institutions (KBOB). Since those databases include only data from resource extraction to factory gate (cradle to gate) and due to the fickle nature of transport's and processes' EE it was considered that their calculation based on distances and number of vehicles used from factory to site would include many uncertainties and those were placed out of the system's boundaries. It is acknowledged, however, that this would underestimate the energy and carbon payback, although it would not induce significant differences between the two cases in comparison.

3.3.2 Operational Energy, CO₂ and Cost Inputs

Operating cost is defined as the sum of energy consumption, maintenance and repair costs (Fuller, 2010). The estimation of these costs is a significant factor, as the greatest part of the building's impact occurs after construction (University of Reading, 1985) and accounts for 78% - 96% of the total consumed energy (Gignac and Jensen, 2007). Required inputs for calculating operating costs are: energy consumption, energy cost savings, gas prices (the refurbished house is heated by gas); predicted gas price trends in the future and assumed discount rate.

Energy consumption for heating was calculated using a multi – zone thermal model produced with EDSL TAS software, having three comparison cases: pre-refurbishment, current refurbished house and EnerPHit refurbished (Table 2). The infiltration rate for the pre – refurbished state (0.53 ach @ STP) was assumed based on Johnston et al. (2011), the current state based on the blower door test results of 5.6 ach/h @ n₅₀ (0.3 ach @ STP) and reduced by one third (0.2 ach @ STP) for the EnerPHit, as the target of 1 (0.05 ach @ STP) was considered unachievable. For the simulations the London Heathrow CIBSE TRY weather file was used, causing probably some deflection from the actual weather conditions (centre of London).

Table 2 Summary of the three iterations' U values (W/m²K)

	Pre refurbishment	Current state	EnerPHit
External Wall – Front Facade	1.24	0.32	0.13
External Walls	1.24	0.5/ 0.32	0.13
Party Wall	0.73	0.73	0.21
Attic Wall	2.17	0.24	0.14
Roof	3.11	0.20	0.13

Attic Floor	2.27	0.35	0.35
Intermediate Floor	2.06	2.06	2.06
Kitchen Floor	0.96	0.32	0.15
Hall Floor	0.96	0.96	0.15
Living room Floor	0.78	0.18	0.134
Windows	4.80	0.8/ 1.7/ 2.1	0.8

The actual house consumption metering files were used for the calculation of hot water heating and electricity consumption, omitting the reduction due to solar thermal and PV panels, as this study focuses only on the evaluation of the thermal envelope measures.

Both calculated and actual energy consumptions were divided by efficiency factors¹ and multiplied by carbon factors. Cost factors were calculated according to Quarterly Energy Prices Indices 2013 (National Statistics, 2013).

3.3.3 Indicators Used

The main indicator used for the comparison between the two cases is CTS, which is derived from the following formula:

$$CTS (\text{£/tCO}_2) = \frac{\text{Lifetime Cost}}{\text{Carbon Saved}} \text{ where}$$

$$\text{Carbon Saved (tCO}_2) = \frac{(\text{OCO}_2 \text{ pre refurbishment} - \text{OCO}_2 \text{ after refurbishment}) \times \text{Lifespan} - \text{ECO}_2}{1000}$$

$$\text{Lifetime Cost (£)} = (\text{OC pre refurbishment} - \text{OC after refurbishment}) \times \text{Lifespan} - \text{IC}$$

Table 3 Indicators and Units

Indicator Abbreviation	Indicator	Unit
CTS	Cost per Ton carbon Saved	£/tCO ₂
OCO ₂	Operational CO ₂	Kg/m ² annum
ECO ₂	Embodied CO ₂	Kg/m ²
OC	Operational Cost	£/m ² annum
IC	Initial Cost	£/m ²
OE	Operational Energy	MJ/m ² annum
EE	Embodied Energy	MJ/m ²

¹ Boiler efficiency for the pre-refurbishment condition was not altered, as this study is focused on the evaluation of the impact of measures concerning the thermal envelope of the building.

4. Life Cycle Analysis

4.1 Operational Energy Use, Cost and CO2 Emissions

The operational energy use was compared between the pre-refurbishment condition, the current and the retrofitted according to EnerPHit standard. Modelling results both with and without the effect of active energy systems (PV and solar thermal) are presented, although only the latter will be analyzed (Graph 1).

Graph 1 Passive measures (thermal envelope only)

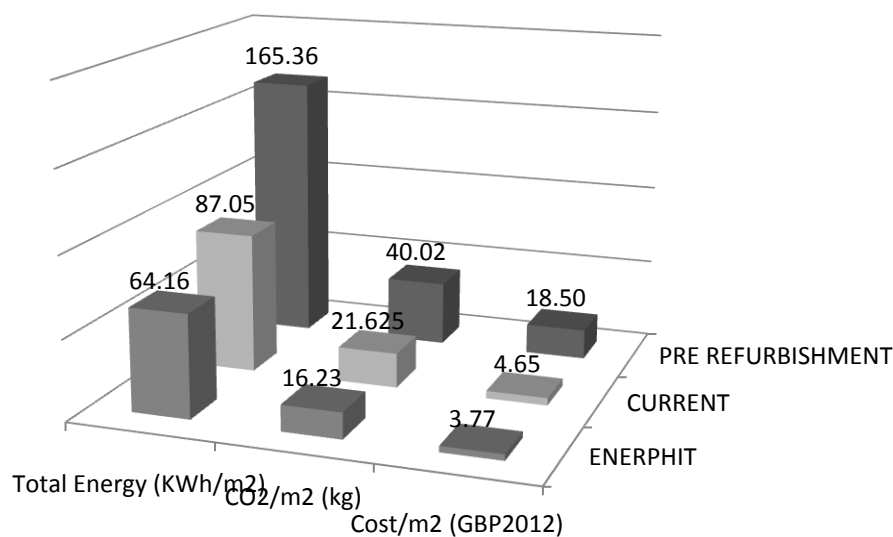

Graph 2 Energy Use Breakdown (KWh/m2a)

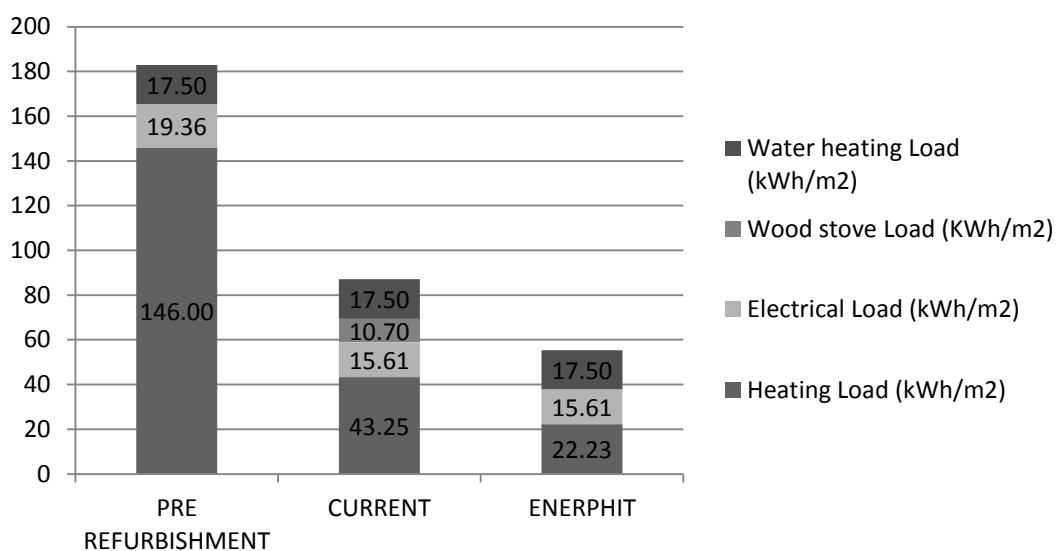

The current house performs significantly better than prior refurbishment, with a 47 % reduction in total energy consumption and 70 % in heating load, while the EnerPHit house would perform even better, with 61 and 85 % reduction respectively (Graph 2). By comparison, the average heating consumption for the existing UK building stock is 180 kWh/m²a, 100 kWh/m²a when renovated and 50-60 kWh/m²a

for new build (Dowson, 2012), which indicates that the current house performs significantly well. The EnerPHit house performs even better, as expected, with a heating demand below 25 kWh/m²a.

In the energy use breakdown it becomes apparent that the primary source of energy consumption is space heating in all cases. The initial un-insulated house had a very high heat space demand, due to high heat losses through the opaque and glazed areas and infiltration as well, which made the improvement of the thermal envelope imperative.

4.2 Embodied Cost, Energy and CO2 Emissions

4.2.1 Cost

As far as costs are concerned², the PH retrofit cost accounts for 130% more than the current one. Graph 3 shows that in both cases the most expensive intervention is the replacement of windows. Interestingly, the current roof refurbishment cost is 2.7 times higher than the EnerPHit, which is attributed to the big price difference between Diffutherm 80mm (£31.3/m²) and Mineral Wool 80 mm (£3/m²). The same applies in the case of external walls, where the same thickness of Woodfibre board costs more than 2.5 times higher than XPS. Thus, the extra costs for increased rafter depth and scaffolding imposed by external wall insulation is almost equalized to the current retrofit's costs. As expected, the 100 % triple glazed windows of the EnerPHit house increase the budget by 156 % compared to the current case. Finally, with regards to air-tightness, for the current refurbishment there is no extra cost recorded, whereas for the decrease from 0.3 to 0.2 ach in the EnerPHit case an extra cost of £1200 was assumed (Johnston et al., 2011).

Graph 3 Total Costs (£/m²)

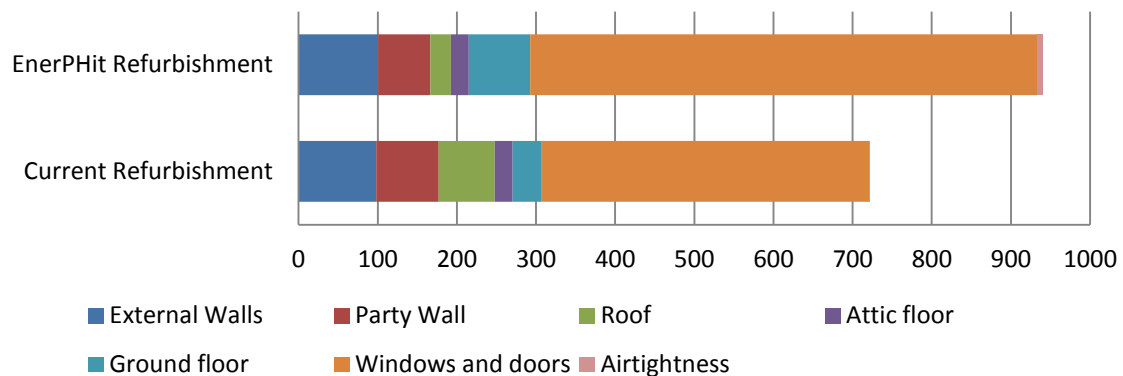

4.2.2 Embodied Energy

From Graph 4 it becomes apparent that the EnerPHit refurbishment EE one is extremely higher (2.4 times more), with walls showing the greatest difference. This is mainly attributed to the use of XPS³ with 88.6 MJ/kg EE, instead of woodfibre board insulation with 20 MJ/kg and the increased thickness needed to achieve the lower U

² All costs were calculated based on 2013 prices.

³ As imposed by the Passive House Certified Components (http://passiv.de/en/03_certification/01_certification_components/01_component_database.htm)

values for the thermal elements. In addition, the triple glazed units and the insulated wooden frames and wooden door with polyurethane foam add 13 % more to the EE.

Graph 4 Embodied Energy (MJ/m2)

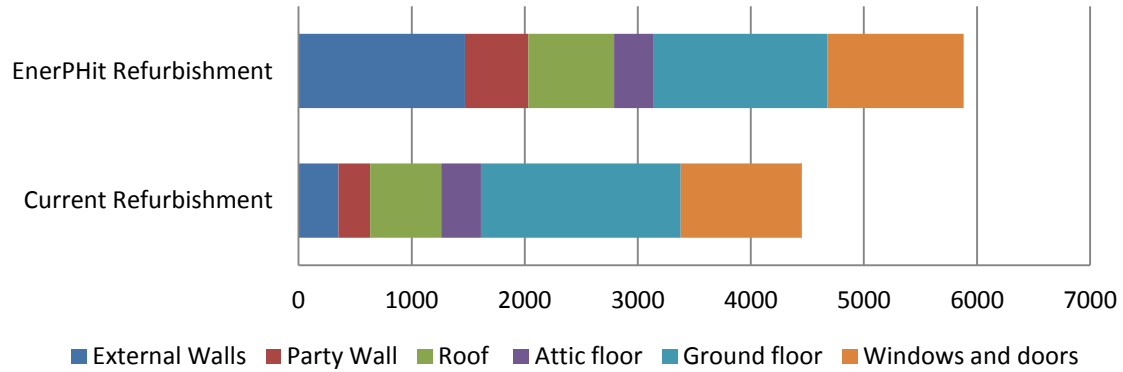

4.2.3 Embodied CO2

Graph 5 Embodied CO2 (kg/m2)

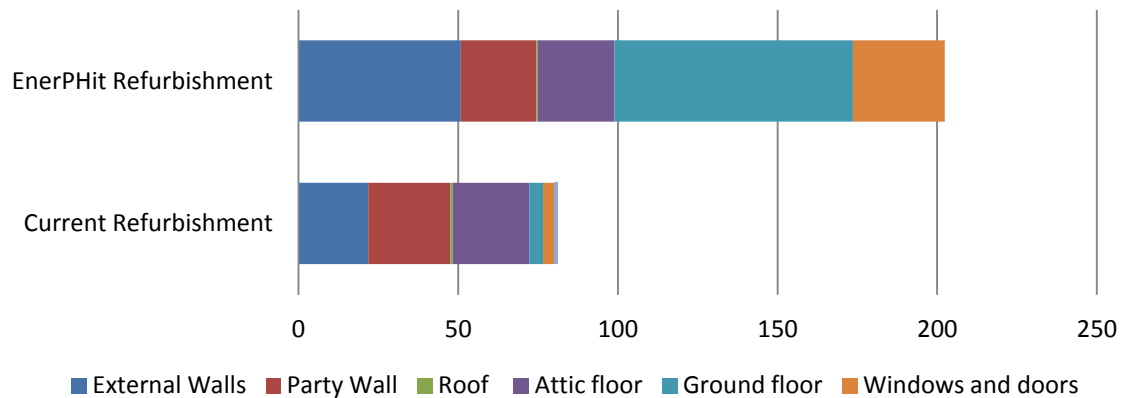

Embodied carbon shows a huge difference between the current refurbishment and EnerPHit in the range of 357%. This is also due to the use of different insulation materials and thicknesses and concrete products for the floor insulation.

4.3 Cost per Ton carbon Saved

The lifecycle analysis over a thirty years lifetime⁴ combines the pre refurbishment operational data with those for post intervention operation and embodied ones as well. The CTS arises as a quotient of the LC divided by the LCS. The savings arising from the EnerPHit refurbishment are constantly higher, although, due to the high amount of EE associated with it, the LCS is higher in the case of the current refurbishment.

The resulting CTS can be evaluated through a comparison to the Social Cost of Carbon for 2012 of £27.17⁵ /tCO2 (Department of Environment Food and Rural

⁴ This was chosen as a likely lifespan of the refurbishment measures.

⁵ £19/tCO2 with 2000 prices, inflated to 2012 prices

Affairs, 2007b), which represents the global cost of the damage a ton of carbon causes over its lifetime in the atmosphere and the price that society should be paying to prevent or mitigate the damage caused.

In both cases the CTS is way above the SCC, with the EnerPHit retrofit being 1.3 times higher than the current refurbishment, indicating that the extra initial cost and EE involved are not offset by the higher savings during the operational phase of the building. In addition, the carbon savings for the EnerPHit are quite delayed compared to the current retrofit, where savings begin just before the second year, resulting always⁶ in higher CTS (Graph 6). In addition, after the 13th year the carbon savings from EnerPHit outreach the current refurbishment.

Graph 6 CTS and LCS Comparison

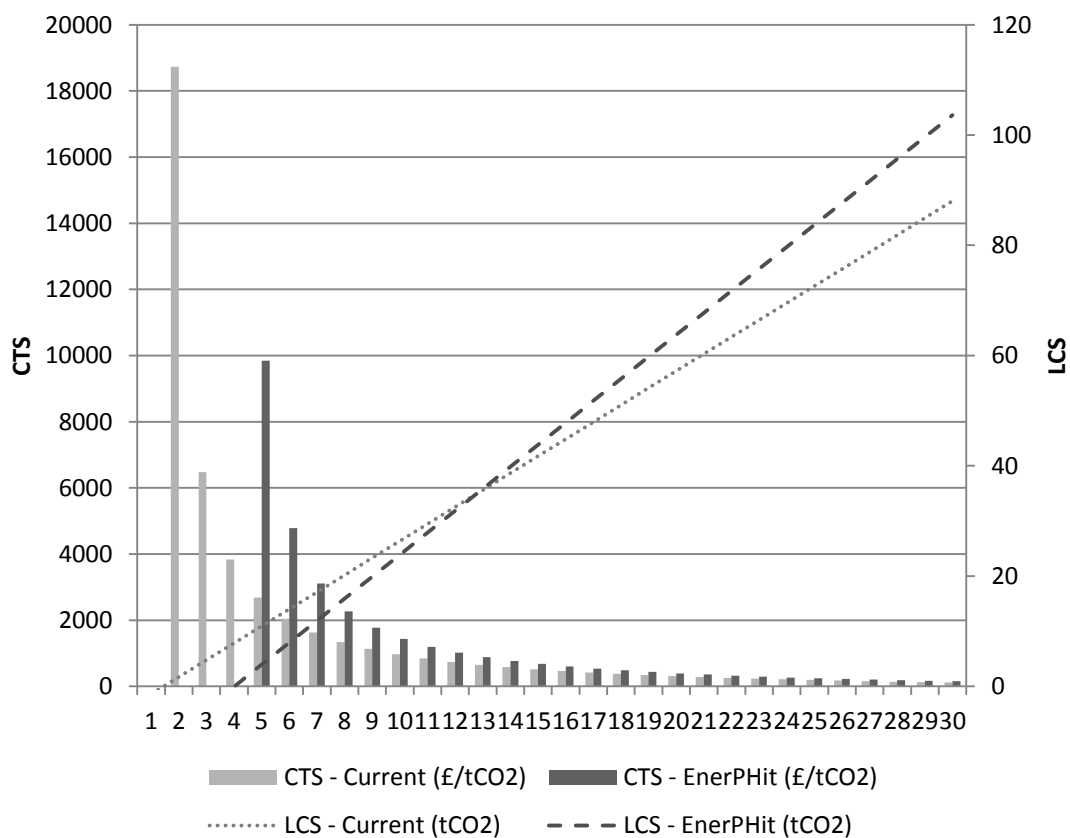

⁶ Values checked for 250 years.

4.4 Simple payback

Simple payback compares the capital investment for a project with the annual benefit, which is assumed to be the same every year, giving the payback period. This method ignores time preference, discounting and the benefits after the payback period and thus should be only used for initial calculations (Ellingham and Fawcett, 2006).

$$\text{Payback Period} = \frac{\text{Capital Cost}}{\text{Annual Income}}$$

In both cases the capital costs are not expected to be repaid after the end of life of the project (30 years), rendering both interventions not cost - effective. With regards to Carbon and Energy, the current refurbishment shows, as expected, shorter payback periods.

Table 4 Simple payback

		Current Refurbishment	EnerPHit Refurbishment
Simple Payback	years	43.18	47.38
Carbon Payback	years	1.45	4.01
Energy Payback	years	5.21	7.75

4.5 Payback period for discounted cash flow

The cash flow of a project associated with future expenditures and incomes is greatly influenced by time preference, which derives from the natural desire to enjoy benefits as soon as possible and to defer payments as long as possible (Ellingham and Fawcett, 2006).

The most critical assumption of LCC is the discount rate, as a high one gives great emphasis on the early years of the project, favouring short – term approaches, while low r favours higher capital investment and a long – term approach. As this project involves low risk, a discount factor of 3.5% was assumed, reflecting the time preference of the UK society (Ellingham and Fawcett, 2006).

The results of NPV for the two alternatives showed that none of the two would give payback in a reasonable amount of time, if discounting is taken into account and steady gas prices are assumed, with EnerPHit having a higher deficit.

5. Sensitivity analysis

Sensitivity analysis is the study of how the uncertainty in the output of a mathematical model or system (numerical or otherwise) can be apportioned to different sources of uncertainty in its inputs (Saltelli A. et al., 2008). In the model developed in this study in order to assess the LCC of the two retrofit cases many assumptions were made and the sensitivity analysis will address the most important of them.

5.1 Gas price volatility

The model used in Chapter 4 considered steady fuel prices, which is highly unlikely to happen in real life. Fuel price volatility can be measured from historic data and can be used to predict the range of possible future outcomes. A quite widespread tool to do that is the binomial tree.

Energy prices show in general upward trends, thus a falling fuel price trend is highly unlikely in NPV costing. The results of the binomial tree for rising and steady fuel prices⁷ are summarized in Table 5, where it becomes apparent that only with rising fuel prices the initial investments would be repaid before the project's end of life, with EnerPHit demanding in all cases longer payback periods. Its NPV is exceeding the NPV of the current refurbishment after the 33rd year.

As far as CTS is concerned, when discounting and rising fuel prices are applied to the calculations, both cases show negative CTS values, indicating profitable investments. Yet again, the current refurbishment shows a higher benefit, which stays above the EnerPHit one for 50 years. On the other hand, when steady prices and discounting are assumed, only the current refurbishment shows negative CTS in 50 years.

Table 5 Payback time comparison

		Current Refurbishment		EnerPHit Refurbishment	
		Steady fuel price	Rising fuel price	Steady fuel price	Rising fuel price
Simple Payback	years	43.18	19	47.38	22
Discounted Payback	years	-	24	-	25
30 Year NPV	£	-20790.33	13754.19	-28465.6	13145.84
30 Year CTS Discounted	£/tCO2	-614.27	-698.7	254.66	-614.49

⁷ With falling gas prices the initial investment is not repaid, so they were not included in the table. In addition, the binomial tree showed for both cases that only one gas price reduction could be accepted in 30 years.

5.2 Impact of climate change

In order to test the validity of the results in case of higher temperatures in the future, a new model was developed using London Design Summer Year weather file. As expected, the total energy consumption was reduced in all cases, with heating loads falling and electricity loads increasing due to additional cooling needed. The overall energy savings are minimized in both cases, especially in the current refurbishment and, consequently, CTS and payback times increase. The current retrofit's CTS is increased by 50% and the EnerPHit's by 47%, while carbon and energy payback times all rose in the range of 20%, rendering both interventions less sustainable. Therefore, it is evident that climate change will influence the benefits of retrofit measures as heating loads and, thus, operational energy savings will decrease, a conclusion applicable in the case of retrofit in warmer climates as well.

5.3 Lifetime effect on CTS and NPV

5.3.1 No replacement

One of the most substantial assumptions taken during the calculations was the project's lifetime of 30 years. The CTS is sensitive to the lifetime cost savings and the lifetime carbon savings and therefore the assumed lifetime. In all cases, carbon payback must be achieved before the CTS can be calculated. In this section the effect of varying lifespans will be addressed, assuming that no additional cost, EE and EC is needed.

As expected, the CTS for a lifespan smaller than the assumed one leads to rocketing of the CTS for both retrofit cases, as the operational energy savings are not enough to offset the initial investments. From Graph 7 it becomes clear that for up to 24 years of lifetime the EnerPHit's CTS is lower than the current one, while from the point they equalize until 90 years lifetime it never exceeds the current one. Interestingly, the current refurbishment starts to generate profit from the 43th year and the EnerPHit from the 47th reaching £-71.76/tCO₂ and £-51.9/tCO₂ by the 60th year respectively.

Graph 7 Effect of lifespan on CTS

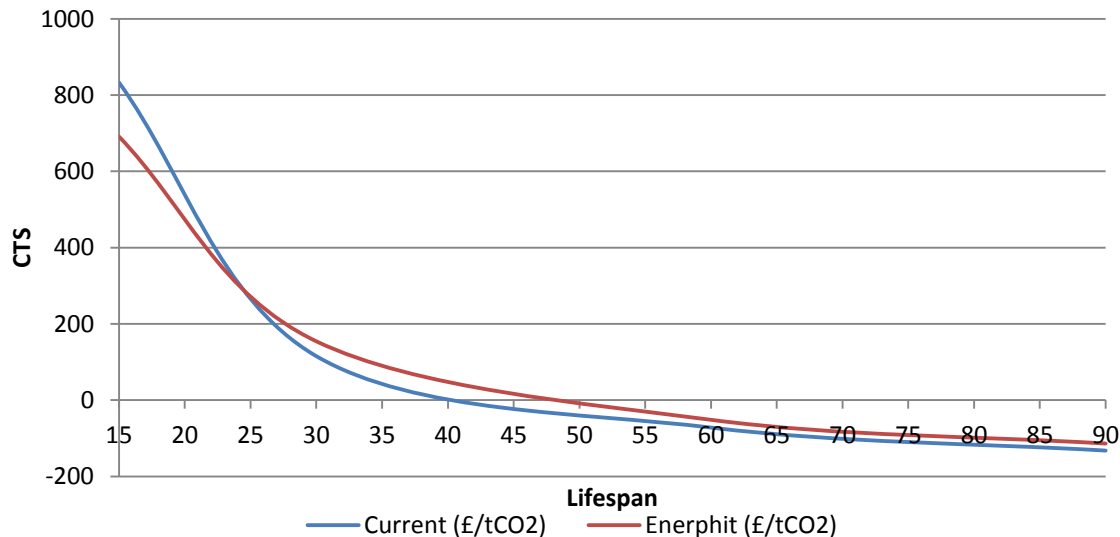

Likewise, the NPV shows different results over different lifetimes. The EnerPHit option becomes more viable than the current one after the 29th year with the difference increasing logarithmically within time, generating very high benefits compared to the initial investment (Graph 8). With steady fuel prices none of the two options is repaid within 90 years.

Graph 8 NPV with rising fuel prices over 90 years

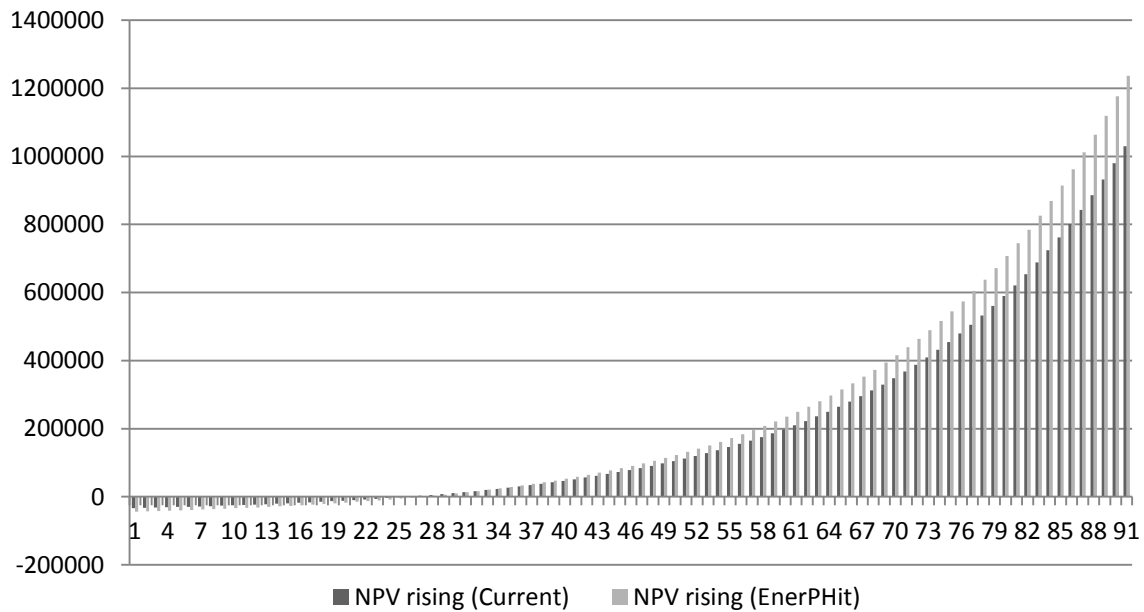

5.3.2 Replacement

In the previous section the effect on various lifespans on the CTS of the two retrofits was addressed, assuming that no additional replacements are needed, which could be considered utopian for a 90 years lifespan. Based on Jakob (2006) five replacement cycles were incorporated in the CTS analysis.

When these replacements are included, no benefit arises within 90 years. Quite interestingly, the carbon saved in EnerPHit manages to outreach the current after the 13th year, even though it is more decreased by replacement cycles (Graph 9). However, the EnerPHit CTS remains constantly above the current one, leading yet again to the conclusion that it is less sustainable.

Graph 9 CTS and LCS including replacements over 90 years

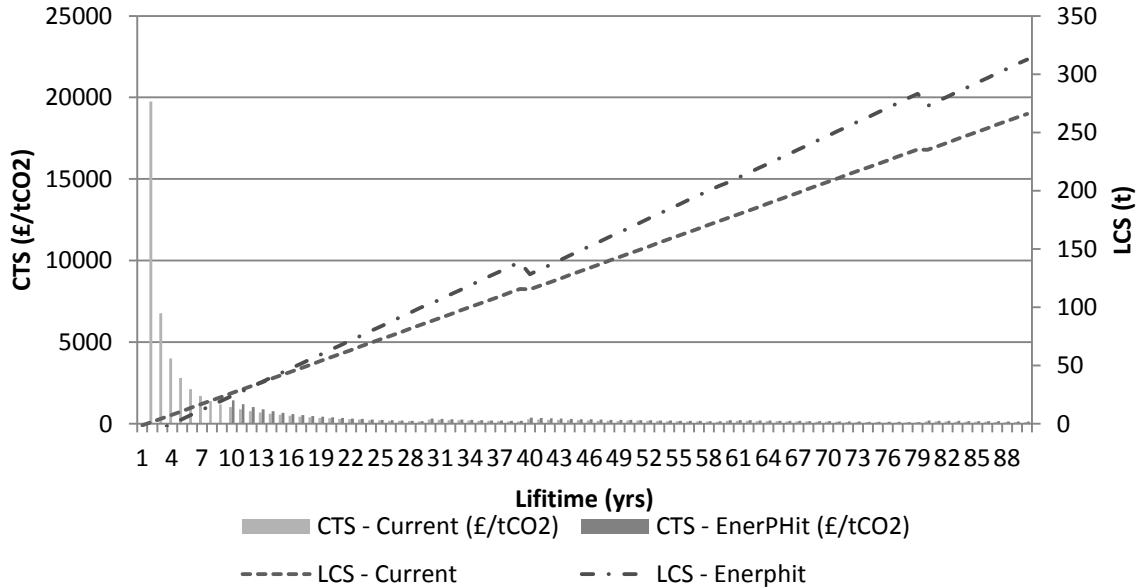

5.4 Discount rate

As described above (4.5), the discount rate is a quantification of uncertainty associated with benefits arising from investments, with high discount rates favouring short-term approaches and vice versa with low. It reflects three factors: inflation, time preference and risk. For the purpose of this study a conservative $r = 3.5\%$ was assumed, based on UK society overall time preference (Ellingham and Fawcett, 2006).

This assumption was tested against the effect it has on the two strategy's NPV with rising gas prices, resulting in favour of the EnerPHit for $r < 3.25\%$ confirming the sensitivity of the results to this input and the fact that low discount rates are advantageous for long term approaches and higher initial investments (Graph 10).

Graph 10 Effect of r to NPV

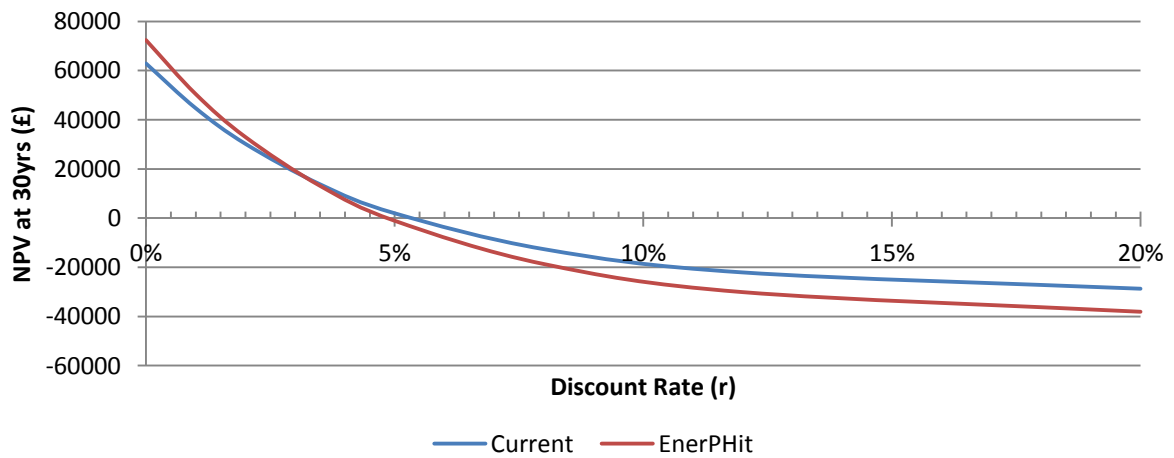

6. Overheating Occurrence

In the previous sections the study was focused on energy consumption; however, one of the main aspects of retrofit is the improvement of the house's thermal conditions, as these have implications on occupants' health. In addition, one of the EnerPHit refurbishment's criteria is the restraint of the overheating percentages ($t > 25\text{ }^{\circ}\text{C}$) below 10%. The pre - retrofit, the current and the EnerPHit cases were tested against this constraint over a 24 hour basis, except for the guest room which is tested only when occupied. Both refurbished cases show significantly low overheating percentages, quite below the strict limit of 10 % over $25\text{ }^{\circ}\text{C}$.

In order to identify the different responses of the house during hot periods, the hottest day of the weather file was chosen and the temperatures in the main living space were modelled (Graph 11). The EnerPHit house performed better, having a $3.4\text{ }^{\circ}\text{C}$ difference of maximum temperature with the outside, followed by the current refurbishment, which responded a little worse. On the other hand, by using the DSY the frequency of overheating appears to be higher for the EnerPHit case (4%), when no additional cooling is implemented.

Graph 11 Living room resultant temperature

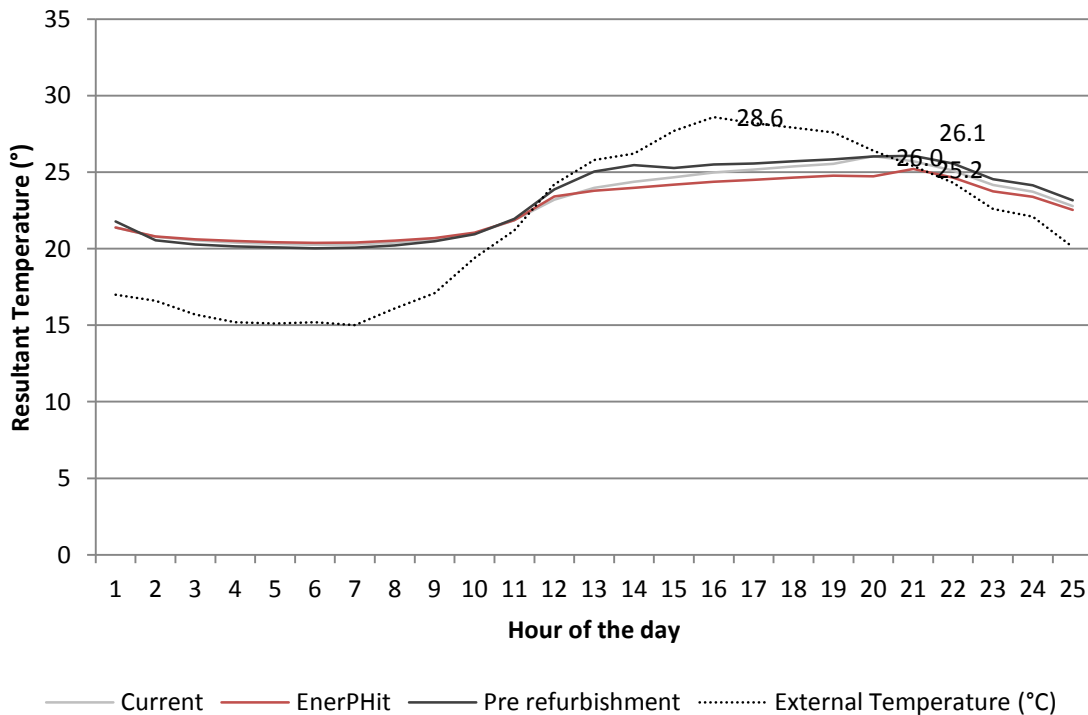

7. Discussion

Aim of this study was to evaluate the most sustainable way to refurbish the thermal envelope of an end - terraced house in London, by comparing issues of cost, EE and ECO₂ between the applied retrofit and EnerPHit standard. At first glance one would assume that since EnerPHit is based on stricter U-Values and therefore higher insulation levels, it would be the optimum alternative by achieving higher operational energy savings, which is translated in cost savings. However, this study proved this hypothesis wrong, as the EnerPHit's price to be paid in order to achieve those higher energy savings in terms of IC, EE and ECO₂ renders it a less appealing retrofit model than the applied one.

The main variable used in order to perform this comparison was Cost per Ton carbon Saved, a quite representative value for the aim of this study as it incorporates all the variables under assessment (IC, OE, OCO₂, ECO₂). The lower CTS the more advantageous the option, with negative values signifying profitable investments. It was concluded that retrofitting in general and especially the application of EnerPHit is a viable option only with rising gas prices, low discount rates and long lifespans. Those results were even more amplified when climate change was taken into account, a conclusion very important for the application of future legislation and the possible transfer of this study to other climates.

When making an investment, the most important concern of the people involved is usually the cost payback time. This study used this parameter as a means to compare the two models, with quite interesting results. First and foremost, it was concluded that with steady (and falling) fuel prices none of the two is ever repaid when discounting is taken into account. In addition, if the imminent climate change is taken into account, both retrofit models appear to be unworthy with extremely long payback times, as energy savings from heating decrease with higher external temperatures. However, with rising fuel prices, which are highly probable according to trends, the two models are repaid within 19 years for the current one and 22 for EnerPHit, with the financial benefits coming from the EnerPHit exceeding the current one after the 33rd year, ending in 20% more NPV in the 90th year (without taking replacements into account). This inference led to another important one: the definition of the lifetime's length is very important in WLC, as significant benefits may arise after the end of the assumed lifespan, leading to incorrect conclusions.

The analysis on lifespans resulted in the same conclusion whether replacement works are included in the analysis or not. The current refurbishment still performed better in terms of CTS in 15, 30, 60 or 90 years. However EnerPHit's NPV is more appealing with rising gas prices and lifespans more than 33 years. One can conclude that the longer the lifespan the more worthy it is to invest more capital initially, thus the EnerPHit model is only viable in houses that do not incur major stresses on their structural framework and are predicted to stand for a long time period, as stated by the Research Group on Cost Efficient Passive Houses as well (Passipedia).

8. Conclusion and Further Research

This study evaluated the existing retrofit applied to an end terraced house in London against a retrofit according to EnerPHit standard, resulting in better results in most cases for the former. However, throughout the study it became evident that retrofitting is only sustainable if energy prices will rise in the future and for climates with high heating degree days, so that the initial investment could be repaid through operational savings. The lifetime is a very significant factor to be taken into account as well, as investments with higher capital cost give higher benefit in long term. Thus, when a building is structurally intact and expected to exist for a long time, it is worth to invest in an extensive retrofit.

On the other hand, one should not overlook that retrofitting has to play an important role on the reduction of CO₂ emissions, as the existing UK housing stock is among the least energy efficient in Europe and is therefore a great contributor to climate change. In addition, energy refurbishment increases the property value and thus rent premiums, improves health and comfort conditions in the house and also acts against fuel poverty. In 2011 4.5 million UK households were spending more than 10 % of their income in order to maintain adequate warmth (Department of Energy and Climate Change, 2013), making the great importance of building fabric to occupant's health apparent, especially to those with lower income. Moreover, retrofit is one of the tools for a gradual release from fossil fuel energy consumption, as the minimization of operational energy makes it feasible to supply a big part of this energy through renewables. Finally, it contributes positively to the creation of work places, especially in densely built cities with low construction rates, a financial benefit that should not be disregarded.

It is suggested that this study is applied on a larger scale as well, so that it could be generalized and applied to governmental strategies towards carbon emissions' reduction. It is important to state here, that minimization of costs would be achieved if retrofits are done massively and with governmental guidance, through bulk discount and expertise effect. The CTS in this case would be minimized and might be comparable to the social cost of carbon.

Finally, further research could be done regarding insulation materials which could be applied in standards. The embodied energy in the materials used in a retrofit is a determining factor of its environmental friendliness and it's always a matter of **how much do we really spend in order to save?**

9. References

- Boardman, B., Sarah Darby, Gavin Killip, M. H., Christian N. Jardine, Palmer, J. & Sinden, G. 2005. *40% House* [Online]. University of Oxford. Available: www.eci.ox.ac.uk [Accessed 11/06/2013].
- Camden Council 2009. Dartmouth Park Conservation Area Appraisal and Management Statement. *In: COUNCIL, C. (ed.)*.
- DECC 2012. Domestic energy consumption in the UK since 1970. *In: CHANGE, D. O. E. A. C. (ed.)*.
- Department Of Energy And Climate Change 2013. Annual Report on Fuel Poverty Statistics 2013. London.
- Department Of Environment Food And Rural Affairs. 2007a. Guidelines to Defra's GHG conversion factors for company reporting.
- Department Of Environment Food And Rural Affairs 2007b. The Social Cost of Carbon and the Shadow Price of Carbon: What They Are, and How To Use Them in Economic Appraisal in the UK. *In: DEFRA (ed.)*. London.
- Dodoo, A., Gustavsson, L. & Sathre, R. 2010. Life cycle primary energy implication of retrofitting a wood-framed apartment building to passive house standard. *Resources, Conservation and Recycling*, 54, 1152-1160.
- Dowson, M. 2012. *18: Passivhaus Refurbishment* [Online]. Available: <http://www.cibse.org/content/microsites/epg/cb18.pdf>.
- Ellingham, I. & Fawcett, W. 2006. *New generation whole-life costing : property and construction decision-making under uncertainty*.
- European Commission. 2009. Low Energy Buildings In Europe: Current State Of Play, Definitions And Best Practice. Available: http://ec.europa.eu/energy/efficiency/doc/buildings/info_note.pdf.
- European Commission 2013. EU greenhouse gas emissions and targets.
- Feist, W. 1997. Life-Cycle Energy Analysis: Comparison Of Low-Energy House, Passive House, Self-Sufficient House.
- Feist, W. 2011. EnerPHit Certification as “Quality Approved Energy Retrofit with Passive House Components”. *In: INTITUTE, P. H. (ed.)*. Darmstadt.
- Fuller, S. 2010. *Life-Cycle Cost Analysis (LCCA)* [Online]. Available: <http://www.wbdg.org/resources/lcca.php> [Accessed 09/06/2013].
- Gignac, F. G. & Jensen, M. V. 2007. Environmental Impacts Of Passive Houses.
- Green Deal Initiative. *Green Deal for Home Owners* [Online]. Available: <http://www.greendealinitiative.co.uk/about-the-green-deal/the-green-deal-for-homes/> [Accessed 20/08/2013].
- Gustafsson, S. & Karlsson, B. G. 1988. Why is life cycle costing important when retrofitting buildings

- Hall, K. 2005. *The green building bible : all you need to know about ecobuilding / publishing editor: Keith Hall*, Green Building Press.
- Hammond, G. & Jones, C. 2008. Inventory Of Carbon & Energy (ICE). Department of Mechanical Engineering University of Bath,UK.
- Harrison, S. Available: <http://www.eco-refurbishment.co.uk/> [Accessed 05/06/2013].
- Hermelink, A. 2009. The life cycle race – silver and bronze go to ... passive house and low energy house. *ECEEE 2009 Summer Study • Act! Innovate! Deliver! Reducing Energy Demand Sustainably* [Online].
- Hernandez, P. & Kenny, P. 2010. *From net energy to zero energy buildings: Defining life cycle zero energy buildings* [Online]. Elsevier.
- HMSO 2008. Climate Change Act 2008. London.
- HMSO 2010. Conservation Of Fuel In Existing Buildings *The Building Regulations*.
- HMSO 2011. The Carbon Plan: Delivering our Low Carbon Future. *In: CHANGE*, D. O. E. C. (ed.). London.
- HMSO 2013a. Code for Sustainable Homes and Energy Performance of Buildings. *In: GOVERNMENT*, D. F. C. A. L. (ed.).
- HMSO 2013b. English Housing Survey
- Headline Report 2011-12. *In: GOVERNMENT*, D. F. C. A. L. (ed.). London: Crown.
- ISO. 2003. *Task Group 4: Life Cycle Costs in Construction. In LCC as a contribution to sustainable construction—Final* [Online]. London. Available: <http://www.ceetb.eu/docs/Reports/LCC%20FINAL%20REPORT-2.pdf> [Accessed 09/06/2013].
- Jakob, M. 2006. Marginal costs and co-benefits of energy efficiency investments. *Energy Policy*, 34, 172-187.
- Johnston, D., Miles-Shenton, D., Bell, M. & Wingfield, J. 2011. Airtightness of buildings — towards higher performance
Final Report — Domestic Sector Airtightness London: Centre for the Built Environment, Leeds Metropolitan University.
- Kah, O. & Feist, W. 2005. Wirtschaftlichkeit von Wärmedämm-Maßnahmen im Gebäudebestand Available: http://www.passipedia.org/passipedia_en/_media/picopen/wirtschaftlichkeit_waermedaemmung.pdf [Accessed 12/06/2013].
- Kbob. 2009. *Ökobilanzdaten im Baubereich* [Online]. Available: <http://www.eco-bau.ch/index.cfm?Nav=20> [Accessed 10/07/2013].
- Langdon, D. 2013. *Spon's architects' and builders' price book 2013* London.
- Lowe, R. 2007. Technical options and strategies for decarbonizingUK housing. *Building Research & Information* [Online]. Available: <http://www.tandf.co.uk/journals> [Accessed 11/06/2011].

- Marc, J. 2001. *Energy and choice of life* [Online]. Available: www.manicore.com [Accessed 06/06/2013].
- Marc, J. 2003a. *What is our present energy consumption like ?* [Online]. Available: www.manicore.com [Accessed 06/06/2013].
- Marc, J. 2003b. *What is the greenhouse effect ?* [Online]. Available: www.manicore.com [Accessed 06/06/2013].
- McMullan, R. 2007. *Environmental science in building / Randall McMullan*, Basingstoke : Palgrave Macmillan
- Metoffice. 2009. *Science: Driving our response to climate change* [Online]. Available: <http://www.metoffice.gov.uk/media/pdf/r/6/informing-mitigation.pdf> [Accessed 06/06/2013].
- Mohammadpourkarbasi, H. 2013. The Eco-Refurbishment of a 19th Century Terraced House: Energy and Cost Performance for Current and Future UK Climates. *Buildings*, 3, 220.
- National Statistics. 2013. *Quarterly Energy Prices* [Online]. Department of Energy and Climate Change.
- Nicholls, R. 2005. *The green building bible : all you need to know about ecobuilding / publishing editor: Keith Hall*, Green Building Press.
- Passipedia. *Economic feasibility of Passive House retrofits* [Online]. Available: http://www.passipedia.org/passipedia_en/basics/affordability/investing_in_energy_efficiency/economic_feasibility_of_passive_house_retrofits [Accessed 12/06/2013].
- Pelsmakers, S. 2012. *The environmental design pocketbook / Sofie Pelsmakers*.
- Power, A. 2008. Does demolition or refurbishment of old and inefficient homes help to increase our environmental, social and economic viability? *Energy Policy* [Online], 36.
- Royal Commission On Environmental Pollution. 2007. *The Urban Environment: Summary of the Royal Commission on Environmental Pollution's Report*. Available: <http://www.rcep.org.uk> [Accessed 11/06/2013].
- Saltelli A., Ratto M., Andrest., Campolongo F., Cariboni J., D., G., Saisana, M. & S., T. 2008. *Global Sensitivity Analysis* [Online]. ohn Wiley & Sons.
- Schnieders, J. & Hermelink, A. 2006. CEPHEUS results: measurements and occupants' satisfaction provide evidence for Passive Houses being an option for sustainable building. *Energy Policy*, 34, 151-171.
- Stern, N. 2007. *The economics of climate change : the Stern review*, Cambridge University Press.
- Super Homes. Available: <http://www.superhomes.org.uk/superhomes/chester-road-north-camden-london/> [Accessed 05/06/2013].
- Taylor, J. 2008. Available: <http://www.buildingconservation.com/articles/consent/consent.htm> [Accessed 05/06/2013 2013].

Thorpe, D. 2010. *Sustainable Home Refurbishment : The Earthscan Expert Guide to Retrofitting Homes for Efficiency*.

United Nations. 2004. *World Population To 2300* [Online]. New York. Available:
<http://www.un.org/esa/population/publications/longrange2/WorldPop2300final.pdf>
[Accessed 06/06/2013].

United Nations. 2013. *Kyoto Protocol* [Online]. Available:
http://unfccc.int/kyoto_protocol/items/2830.php [Accessed 07/06/2013].

University Of Reading 1985. *Life cycle costs for architects : a draft design manual*,
Whiteknights, Reading : College of Estate Management

Considerations for occupant behaviour modelling in early design stages

Astrid Roetzel

Deakin University, School of Architecture and Built Environment, Geelong, Australia,
astrid.roetzel@deakin.edu.au

Abstract

This paper presents an ideal and worst case scenario approach for occupancy modelling in early design stages which can be used in building simulation. It defines the range of impact that occupant behaviour can have on comfort and energy performance in buildings, and can thus contribute to the decision making of architectural projects in early design stages.

Keywords: Occupant behaviour, building simulation, early design stages, comfort, energy performance

1 Introduction

In the context of the climate change, one research focus is to identify parameters that play an important role in the reduction of greenhouse gas emissions related to buildings. The behaviour of occupants in buildings is one of these parameters, and the lack of consideration of occupants in comfort and energy performance predictions has been identified as one reason why predicted and actual performance often deviate significantly.

Many studies are now trying to close this knowledge gap by attempting to translate the complexity of human behaviour into behavioural patterns which can then be represented by mathematical algorithms for use in calculations and simulations. One important question in this context is however, what level of resolution of these patterns and formulas is required for different stages of design. Very accurate monitoring of occupant behaviour in field studies can lead to very accurate algorithms, however these are most likely to be applicable only in contexts that are similar to the context of the original field study. Such an accurate approach is most useful for optimisation of existing buildings and in later design stages of a project when the all contextual parameters and project details are available. In early design stages however, where architects typically establish a hierarchy of design parameters, such contextual details are usually not yet known. It is the early design stages though, that offer the largest optimisation potential for greenhouse gas emissions and comfort.

This paper presents an ideal and worst case scenario approach for occupancy modelling in early design stages which can be used in building simulation. The approach presented should be viewed as an invitation for further discussion rather than a finalised proposal.

2. Influences on occupant behaviour as derived from the literature

The parameters below are discussed with particular focus on naturally ventilated buildings in early design stages. The discussion below is the summary of a more detailed literature investigation as indicated in the references.

2.1 Occupancy and use of office equipment

The schedule for occupancy in buildings has significant impact on the buildings energy consumption and it also defines the magnitude of internal heat loads, i.e. for how long office equipment is running. Typical occupancy schedules (Rubinstein et al. 2003) cover a period of 10–14 h which are equivalent to 6–8 h with 100% occupancy. The major influence that defines the occupancy schedule is the task that a person has to perform, and this also defines presence and absence patterns, the required office equipment (power of computer and monitor), as well as the intensity of use of this equipment (presence and absence from the computer/room).

2.2 Occupant controlled natural ventilation

Natural ventilation controlled by occupants via openable windows is influenced by a large variety of parameters related to the climate, the façade design, and the psychological or social environment (Ackerly et al 2011 , Burak Gunay et al 2013, Roetzel et al 2009).

Many window opening models have emerged out of field studies, and as pointed out by Ackerly et al, (Ackerly et al 2011) the literature agrees on the non-deterministic nature of window control. Apart from that the individual models differ significantly, and models intended for use in building simulation have become increasingly complex. Out of 10 different window opening models (Roetzel et al 2009), the adjustment parameters were (in order of occurrence in the models): outdoor temperature, indoor temperature, time of day/previous window opening angle, and with minor occurrences: occupancy, rain, indoor pollution, CO₂ concentration, occupant type (active/passive), and wind. It should be noted that most of these models are based on field studies in a moderate climate such as UK, Switzerland and Germany, with the exception of one model based on the Pakistani context.

In the development of window opening models there seems to be a trend towards an inclusion of more and interacting parameters to better reflect contextual influences. In early design stages, many of these parameters however are not yet known and the modelling should not be too time-consuming in order not to be an obstacle for investigation. Therefore a balance has to be found between the precision of many parameters and the simplicity of a few. The following can be summarized:

- Most recent window opening models agree that outside as well as indoor temperatures are the most crucial parameters. Especially in warm climates with a large diurnal swing this temperature difference is an important parameter.
- Time dependent models that correlate window operation with arrival or departure seem more suitable to moderate climates. In warm climates these patterns are likely to be superposed by temperature based window operating patterns, i.e. closure if outside temperatures exceeds the indoor temperatures.
- Most models considering the previous window state are based on window types which can have two states, closed and open, such as bottom hung windows which are common in Northern Europe. In warmer climates, window types seem to be more common which allow for larger opening areas as well as more adjustment opportunities such as sliding windows, side hung windows, and top hung windows which can be open, closed and allow for various opening angles. These window types

are not very well represented by models which only allow for the status 'open' or 'closed'.

- Wind, rain and other local climate characteristics have been mentioned in several studies as influential on window operation. However this impact is also dependent to the window type.
- The indoor air pollution as well as the CO₂ concentration in a room can have significant impact on the window operation by occupants, and it may override other criteria in severe cases.
- Night ventilation can significantly contribute to the cooling of a building, but in most cases it depends on the security policy whether or not windows can be left open at night.

2.3 Lighting control

Occupant controlled light switching is influenced by a large variety of parameters (Bordass et al 1993, Bourgeois 2005, Reinhart and Voss 2003, Galasiu and Veitch 2006, Moore et al 2003). Potential influences as derived from the above mentioned literature can be categorised as building related or occupant related. Building related influences are:

- Orientation and site context, i.e. exposure to direct vs. diffuse daylight, but this can be affected by blind control, too.
- Office type and number of occupants in the room, as well as the type of lighting system. E.g. for room related lighting the individual use of controls is likely to be lower the larger the number of people in the room. Switching by one individual might then affect the visual comfort of all others, and 'no change' could be the most likely common denominator.
- Location of controls, i.e. whether lighting can be controlled from each individual workplace or via a central switch at the door. If all occupants share one central switch, i.e. for room related lighting, then the use of the control is likely to be lower the larger the room size (distance to control unit, potential impact of change on other occupants).
- Distance of occupants from windows, i.e. a person who is placed further away from the façade is likely to activate the lighting earlier in the evening than someone closer to the façade where daylight levels are likely to be higher.

Individual influences on lighting control by occupants are:

- Task, i.e. how much time occupants spend working on a computer screen, since lower lighting levels tend to be acceptable for work on a screen (~300lux) compared to other tasks (500lux).
- Active or passive occupants, where active occupants adjust the lighting throughout the working day, whereas passive occupants tend not to change the lighting conditions during the day.
- Psychosocial influences such as cultural background, age, degree of fatigue. These parameters are based on individual preferences and expectations.

2.4 Blind control

Occupant controlled blind switching is another important parameter that affects a buildings comfort and energy consumption (Inkarojrit 2005, Rea 1984, Boubekri and Boyer 1992, Newsham 1994, Bulow-Hube 2000, Foster and Oreszczyn 2001, Osterhaus 2008, Sutter et al. 2006, Galasiu and Veitch 2006, Tuaycharoen and Tregenza 2007, Reinhart and Voss 2003). Since it influences the levels of daylight in the room it indirectly affects the artificial light switching patterns, too. As a result of the literature review, there is a difference between

active and passive users, passive occupants are keeping the blinds closed all day, whereas active occupants adjust the blinds according to glare and/or overheating.

The most important blind switching criteria are related to either glare, overheating or privacy. Overheating is related to the difference between indoor and outside temperature, and only at uncomfortably high indoor temperatures this is a likely reason for blind switching. Privacy as a reason for blind control is likely to lead to closure of blinds throughout the working day, i.e. in rooms that are particularly exposed so that occupants feel observed by others. Glare is a very complex blind switching criterion, that is influenced by a variety of parameters of which the following are the ones most mentioned in the literature:

- Orientation and sunlight penetration together with the distance of occupants from windows, i.e. the relationship of the sun angle within the field of vision of occupants.
- Window area of the façade and window arrangement, which impacts the luminance differences, but also depends on climate and external obstruction.
- Type of shading system, which predefines the balance of shading vs. daylighting.
- Task and quality of a computer screen, which can make a slight difference to the glare sensitivity of occupants if the task involves work on a computer.
- Visual and aesthetic interior qualities of the room, which has an impact on luminance contrasts and indirectly affects glare tolerance
- View quality, i.e. attractive views result in a higher tolerance to glare than less attractive views.

3. Evaluation of influences on occupant behaviour for modelling in early design stages

In the light of current efforts to reflect the behaviour of occupants in building simulation, the paragraphs above aim to summarize parameters that are relevant for occupant's behaviour related to occupancy and use of office equipment, natural ventilation, lighting control and blind control. The following paragraphs further examine the above mentioned parameters for their suitability to be used in an occupant behavioural model for building simulation in early design stages.

In early design stages of an architectural project, there is usually no budget and not enough time for a detailed investigation of the whole building context, in order to develop very accurate algorithms, and many parameters might not be known or available yet. A simplified method is therefore desirable, and a balance has to be found between the benefits of simplicity and the related sacrifice in accuracy. In terms of comfort and energy performance optimisation however, early design stages are crucial, and the fact that many parameters might not yet be known, also means that they can still be influenced towards comfort and sustainability.

Table 1 illustrates the influences on occupant behaviour that have been derived from the literature review above. It also shows an assessment of the significance of the criteria, 1 being parameters that are more likely to superpose others, and 2 being parameters which are potentially of similar importance but likely to be superposed by others. This assessment has been made based on experiences from the literature review. The last two columns indicate which of the investigated parameters are available in early design stages. This column basically differentiates between known, not known and optimisation potential. The latter are those parameters, which are not necessarily known or decided upon in early design stages. As such they represent an optimisation potential for early design stages. These are criteria which may still be influenced in order to improve comfort and energy performance in the building.

Table 1: Parameters influencing occupant behaviour, and evaluation of significance in early design stages

Type of occupant control	Parameter	Sub parameter	Significance for comfort and energy performance Rating (1 = high, 2=medium / interdependent)	Known in early design stages?
Occupancy	Individual task / job description	Presence / absence patterns	1 Significance increases the less people in an office (e.g. cellular)	x No, unless tenant is known
Use of office equipment	Individual task / job description	Type of office equipment	1 Significance increases with intensity of use	x No, unless tenant is known
		Intensity of use	1 Major impact on internal heat loads	x No, unless tenant is known
Window control daytime / night time	Climate	Outside temperature	1 Major impact, in combination with indoor temperatures	✓ Yes (weather data)
		Inside temperature	1 Major impact, in combination with outdoor temperatures	✓ Yes, Simulation output
		Wind	2 Impact depends on window type, orientation and climate	✓ Yes (weather data)
		Rain	2 Impact depends on window type, orientation and climate	✓ Yes (weather data)
	Façade design	Window type	1 Defines air exchange rates and suggests control patterns, depending on size and placement	✓ Optimisation potential, preferred type depends on climate and adjustability
		Window size and placement	1 Defines air exchange rates and suggests control patterns, depending on window type	✓ Optimisation potential, different sized openings at different places
	Indoor environm.	Indoor air pollution / CO ₂ concentr.	1 Can superpose opening pattern	x No
	Occupant	Time of the day (arrival, intermediate, departure)	2 In warm climates likely to be superposed by temperature patterns	x No, unless tenant is known
		Previous window state	2 Depends on window type	x No, depends on window type
		Psychosocial	1 Large uncertainty	x No

		influences		based on individual preference and expectation		
	Security (for night ventilation only)	Insurance policy	2	Will depend on façade and location	✓	Optimisation potential: early discussion with insurance
Lighting control	Individual influences	Task	1	Amount of time spent on computer screen	x	No, unless tenant is known
		Active or passive	1	Affects frequency of switching	x	No
		Psychosocial influences	1	Large uncertainty based on individual preference and expectation	x	No
	Building related influences	Orientation	2	Influence of direct sunlight, but likely to be superposed by blind control	✓	Optimisation potential, consider lighting together with shading
		Office type, number of occupants in room	1	The larger the number of people the less likely individual action for room related lighting	✓	Yes or optimisation potential, task area lighting might be more useful in large rooms
		Type of lighting system (task area or room lighting)	1	Impact for room lighting depends on number of people in room	✓	Optimisation potential, task area lighting preferred
		Location of controls	2	Impact depends on room size	✓	Optimisation potential, ensure accessibility
Distance of occupant from window		1	Impact increases with distance from window	✓	Optimisation potential, ensure daylighting in all spaces	
Blind control	Glare	Orientation, sunlight penetration	1	Sun angles predefine switching patterns	✓	Optimisation potential
		Window area of façade	2	Impact depends on other factors e.g. climate, obstruction	✓	Optimisation potential
		Window arrangements	2	Windows in view area are most influential	✓	Optimisation potential
		Distance of occupant from window	1	In combination with orientation predefines switching patterns due to sun	✓	Optimisation potential

			angles		
	Type of shading system	1	Impact on daylighting	✓	Optimisation potential, shading preferred that ensures daylighting
	Quality of computer screen	2	Little difference in case of full glare/disability glare	x	No
	Task	1	Amount of time spent on computer screen	x	No, unless tenant is known
	Visual and aesthetic interior qualities of the room	2	Impact on luminance contrasts and indirectly on glare tolerance	x	No
	Active or passive	1	Affects frequency of switching	x	No
	View quality	2	Indirect impact on glare tolerance	✓	Possibility to influence decision
Over-heating	Indoor temperature in relation to outside temperature	1	Influence stronger the higher indoor temperature	✓	Simulation output
privacy	Exposition of the room towards to outside environment	1	Influence stronger the more exposed the room is and the less occupants	✓	Possibility to influence decision

In order to develop an occupant modelling approach for early design stages, at this stage of the parameter analysis the following considerations have been taken into account. The focus of comfort and energy performance modelling is typically the testing of different variations in order to support or discard design decisions. Many parameters are not yet known, so that input data cannot yet be obtained at a high level of precision. As a result of that the simulation results have to be evaluated as ballpark figures that incorporate a certain level of uncertainty. However, they are detailed enough to compare different variations. With this in mind, the development of an occupancy model for early design stages focuses primarily on those parameters in table 1 which have been identified as those who are likely to override other parameters.

Their potentials and limitations for modelling in early design stages and a proposal for an ideal and worst case scenario are further discussed below. The suggestions below are meant to be a starting point for further discussion and research and when applied to building simulation, they can be altered according to the project's requirements.

3.1 Use of office equipment

As identified in table 1 the two major parameters influencing the internal heat loads by office equipment are the type of equipment and the intensity of use. Both depend strongly on an

individual employee’s job description. I.e. an IT job would require a rather powerful set of office equipment running for the full day, while certain management jobs might require a lot of personal meetings but very little actual use of office equipment. Also the choice of office equipment becomes more significant the higher the intensity of use is. In any case, none of this information is likely to be known in early design stages of a project, and it may also change dramatically after e.g. a tenant change.

It can therefore be useful to define a set of different occupancy patterns which allow for testing of different configurations. One source for such patterns can be the Energy Calculator for PC Equipment (EU-Energy Star), which indicates appliances that meet certain standards regarding energy efficiency. It provides the power of different computer and monitor types in on, sleep and off mode, and suggests different types of use depending on how many hours of the day the chosen equipment is running in these three modes. In terms of energy consumption and thermal comfort predictions, an ideal and worst case scenario can be useful in early design stages. The use of a ‘worst case scenario’ with powerful equipment and high intensity of use can be a conservative estimate for the majority of other office tasks, and it allows for some latitude in case of a tenant change. The ideal case can then indicate the magnitude of optimisation potential related to office equipment. Not in all cases the full magnitude of optimisation will be realistic, but the ideal scenario could at least trigger a rethinking of common practice and raise the awareness of the impact of office equipment. A suggestion for the power consumption and usage pattern for such an ideal and worst case scenario is shown in table 2.

Table 2: ideal and worst case scenario for use of office equipment based on the Energy Calculator for PC equipment (EU-Energy Star)

Ideal scenario, Electricity consumption per year: 21.4 kWh/year		On	Sleep mode	Off mode
Usage pattern	Light office (h)	2	9	13
Equipment	Large notebook 17-18”	25.5	1.7	0.9
Worst case scenario, Electricity consumption per year: 580.3kWh/year		On	Sleep mode	Off mode
Usage pattern	Busy office (h)	8	2	14
Equipment	Workstation (W)	190	7.4	1.5
	Top 27” LCD	103	1.9	0.6

3.2 Occupancy

The presence and absence of occupants and related internal heat loads in offices are strongly depending on their task and the specific job description. Some tasks require constant presence in the office e.g. a processing task at the computer. Some other tasks, e.g. senior management or field staff are likely to spend a large amount of time outside the office, and in cases where the task requires constant customer contact, the number of occupants might be more than just the number of employees.

An ideal and worst case occupancy pattern should be consistent with the usage pattern for office equipment. The suggestion below is derived from the light and the busy usage pattern of the Energy Calculator for PC equipment (EU-Energy Star) mentioned above. The distribution of the ideal scenario is equivalent to 2 hours, and the worst case scenario to 8

hours full time occupancy per person and day, and both patterns are illustrated in figures 1 and 2.

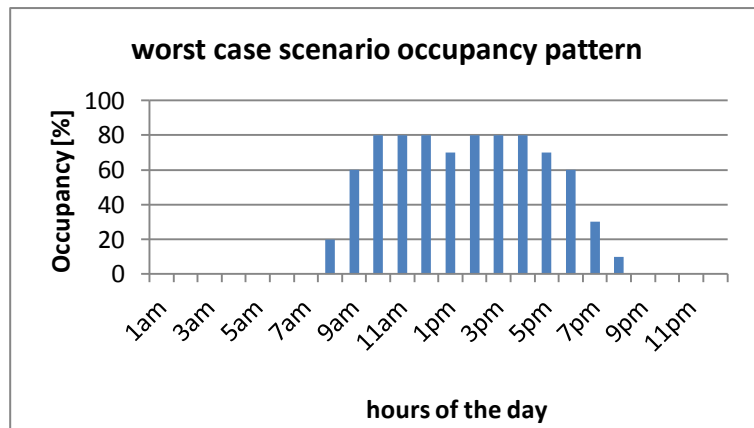

Figure 1: Occupancy pattern, worst case scenario

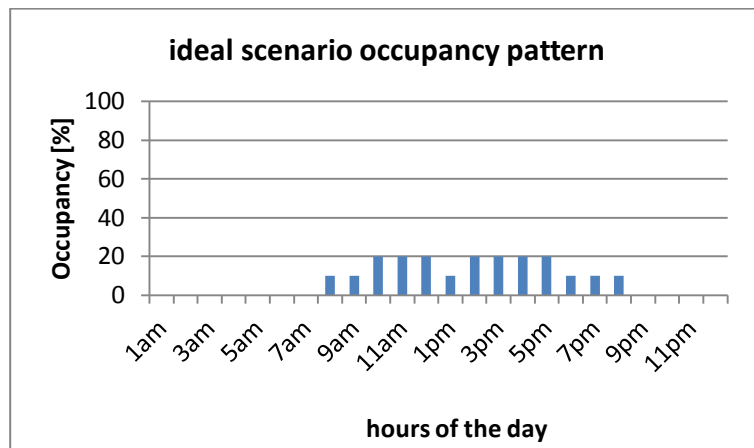

Figure 2: Occupancy pattern, ideal scenario

3.3 Window control day time

Occupant controlled window operation has been a focus of research in recent years, and from the literature review it can be observed that most studies agree on the importance of outside and indoor temperature as well as their difference. Outside temperature can be obtained from weather data sets or observations, and indoor temperatures can be obtained as output of thermal simulations.

Another parameter which is defined in table 1 as one which is likely to superpose others are window type, size, and placement in the façade (Roetzel et al 2009). Although research on this aspect is not as extensive as on temperatures so far, the impact is no less significant as these parameters predefine the air exchange rate, and suggest certain control patterns. In early design stages it is likely that these parameters are not yet completely specified. For this reason it will be difficult to incorporate this aspect into an occupant behavioural model for early design stages. However recommendations should be given at this stage that can help architects with the specification of the fenestration. Certain window types lead to higher air exchanges, other provide better weather protection, and different sizes might be useful for different seasons. In summary it can be stated that the more opportunities for adjustment are

provided, the more occupants will be likely to make full use of these window control opportunities.

High indoor air pollution or CO₂ concentration can easily override typical window opening patterns, however these parameters are not available in building simulation software such as EnergyPlus, and they are very difficult to predict in early design stages as they depend strongly on the materials of the interior fit out. Instead of consideration in the occupant behavioural model, recommendations should be given to carefully select the materials for the internal fit out in order to avoid negative effect on air pollution. Sufficient and accessible ventilation openings that suit the room size and the number of occupants in the room can also help to avoid high CO₂ concentrations.

Another parameter of importance which is too difficult to predict in early design stages is the cultural background, expectations and other psychosocial influences. However a recommendation can be given that the results of such a model should be evaluated with a certain level of uncertainty in mind.

Additional parameters which have been rated as those which can be superposed by others are wind and rain, time of the day and previous window state. The impact of wind and rain can be influential, however the magnitude of influence depends predominantly on the window type, the orientation of the façade and the whether there are dominant climatic phenomena. The time of the day (e.g. arrival, intermittent, departure) as a window operating criterion is in warm climates likely to be superposed by temperature patterns, i.e. the closure of windows due to outside heat at some stage during the day when the outside temperature exceeds the indoor temperature. The applicability of the previous window state depends on the window type, i.e. whether the opening is steplessly adjustable, whether it can be only open or closed, or whether there are more than those two predefined opening states.

It can be concluded that the predominant parameters which can be considered in an occupant behavioural model for early design stages are inside and outside temperatures. According to field studies, for occupant controlled natural ventilation the difference between active and passive occupants was not as strong as for lighting and blind switching and for this reason, the differentiation between an ideal and worst case scenario for daytime ventilation does not seem necessary.

As indicated in the literature review above, there are several algorithms available that define window opening patterns based on indoor and outside temperature, many of which take additional parameters into account as well. For early design stages, the most suitable one should be chosen depending on the climate and the context. The Humphreys adaptive algorithm (Rijal et al 2008) has the advantage that it only considers the indoor and outside temperature, and the resulting window opening probability can be translated into window opening angles for different window types (Roetzel et al 2011).

3.4 Night ventilation

Night ventilation is likely to be influenced by the same parameters as ventilation during day time. However the resulting opening pattern will be different, since it is mainly a decision made at the departure of occupants in the evening whether or not the window will be open all night until their arrival in the next morning. The predominant impact on night ventilation however is the window type and size as well as the placement in the façade. Often office buildings do have openable windows, but the security policy of the company does not allow

them to be open during night time, and often this is due to insurance reasons. Therefore again in early design stages, recommendations should be provided to architects to design burglary safe night ventilation openings. These can be developed in cooperation with an insurance company to provide a backup for a company policy.

In contrast to day time ventilation, where no ideal and worst case scenario seems obvious, for night ventilation this differentiation can be made. In an ideal case, night ventilation could be applied either consistently during the cooling season (which has to be determined individually for each climate) or initiated depending on the daytime window opening algorithm. For the worst case scenario, windows would be always closed during night time and no night ventilation would be possible.

3.5 Lighting control

The most influential parameters on lighting control as determined in table 1 are related to either the individual occupants or the building. On an individual basis it is important whether or not occupants spend most of the time at a computer, since in this case lower illuminance levels tend to be accepted. In early design stages none of this information is likely to be available. Psychosocial influences are important as well, such as age, degree of fatigue, and the literature review suggests a differentiation between active and passive light switching behaviour. Active users are adjusting the artificial lighting levels throughout the day, depending on daylight levels. Passive users however, were observed to leave the light on throughout the working day independent of daylight levels.

An additional significant influence on light switching is the type of the lighting system, which predefines a number of other influences. In case of room related lighting with a single control point (i.e. light switch at the door), it is the more likely that the light remains switched on all day, the more occupants are in the room since light on might be the common denominator. Also the distance of occupants from the façade is important since the person in the darkest area of the room is likely to require artificial lighting for longer periods of the day than occupants closer to the façade.

In early design stages, the future occupants of a building and related individual influences are often not yet known. Also building related influences will depend on the characteristics of the project, and are still likely to change. As such, any detailed modelling is very difficult throughout early design stages.

In summary it can be concluded, that an ideal and a worst case scenario for light switching represents the observations of active and passive behaviour, and the magnitude between both scenarios illustrates the uncertainty in occupant behaviour due to parameters which are not yet known in early design stages such as number of occupants and type of lighting system. An ideal scenario assumes light switching according to daylight availability, i.e. with a set point of 500 lux (or 300 for computer tasks). And the worst case scenario would assume the light to be switched on throughout the working day.

3.6 Blind control

The most influential parameters on blind control by occupants are related to glare, overheating and privacy (table 1), and as for lighting control the literature suggests a differentiation between active and passive occupants.

Although table 1 does not provide a complete list of parameters which affect the perception of glare, there is a large number of parameters which are influential and not all of them are easily measurable, such as the view quality or the visual and aesthetic interior qualities of the room. As indicated in the literature review glare is therefore very difficult to measure and in early design stages many influential parameters are not yet known.

One simplified index for glare evaluation is the Discomfort Glare Index (DGI) (Hopkinson 1970 and 1972) which only takes into account the luminance difference between the window and the surrounding background as seen from a reference point. It does not reflect the complexity of the perception of glare in real buildings, however in its simplicity it might be well suitable for early design stages and it is available in simulation software such as EnergyPlus. However one should be aware of the lower level of resolution of the results and factor this into the decision making based on a glare evaluation using the DGI.

Another influential parameter on blind switching is overheating protection, and depending on the climate zone this parameter will be most influential during cooling period of a building. Blind switching for overheating protection is likely to occur when the sun is shining on the façade, and the room temperature have reached the upper level of the comfort threshold. In a study in France, the threshold 200W/m^2 for solar radiation on the façade and a room temperature of 26 degrees Celsius was suggested (Sutter et al 2006). These thresholds might be adjusted for different climate depending on local specifications.

The third major influence on blind switching is related to a need for privacy by occupants. While in an existing building such behaviour might be observed in a field study, in early design stages there can only be an educated guess which rooms in a building should be flagged for the potential of blind closing due to privacy, since it also depends on the individual occupants. Typically it would be those which are very exposed to external or internal distractions, and these can range from visual distractions by passing traffic to psychological distractions by feeling observed by colleagues.

In early design stages, most of the influences on blind switching are not yet known, and as for light switching, a simplified approach based on an ideal and worst case scenario seems more appropriate. The worst case scenario would assume that blinds are closed throughout the working day, e.g. for privacy reasons or due to passive users. From a comfort and energy consumption point of view, this requires the artificial lighting system to be constantly switched on which increases the energy consumption as well as the internal heat loads. And an ideal scenario would assume that blinds switching is depending on either heat or glare, i.e. 'glare (DGI threshold)' or 'solar radiation on the façade + room temperatures above a defined threshold', whichever occurs first. Especially in office environments where work on computer screens can be expected, it is likely that glare is the more sensitive criterion compared to overheating. Glare tends to affect blind switching especially at low sun angles in the morning or evening, where overheating might be less dramatic. Also the switching behaviour will depend to some extent on the shading system itself and the control opportunities it offers.

4. Conclusions

Table 3 summarizes an ideal and worst case scenario approach to occupant behaviour modelling as explored in this paper. The magnitude of difference between both scenarios can help to evaluate the impact which occupants can have on comfort and energy performance in a particular building. The design recommendations can be indicative for architects and clients,

in order to achieve the configurations of an ideal scenario. This approach should be considered as an invitation for further discussion and further research, rather than a final proposal.

Table 3. Ideal and worst case scenario and design recommendations for occupant behaviour modelling in early design stages

	Ideal scenario	Worst case scenario	Design recommendations
Office equipment (ref table 2)	Notebook, in on-mode for 2h per day = 21.4 kWh/year	Workstation in on-mode for 8h per day = 580.3kWh/year	- Use notebooks instead of desktop computers, where possible
Occupancy (ref figure 1 and 2)	2h presence distributed over working time	8h presence distributed over working time	- Avoid locating tasks that require powerful equipment in rooms which are exposed to solar radiation
Window opening daytime	<ul style="list-style-type: none"> - Any suitable algorithm which considers the relationship of outside and inside temperatures, e.g. Humphreys adaptive algorithm (Rijal et al 2008). - Potential for translation of window opening probability into window opening angles for specific window types according to (Roetzel et al. 2011) 		<ul style="list-style-type: none"> - Choice of window types considering air exchange rates, weather protection, + seasonal climate - Provision of sufficient and different sized ventilation openings in different parts of the façade. - Ventilation openings do not need to be windows - Choice of internal fit out considering room air quality - Dominant climatic phenomena at the location? - Consider uncertainty, due to psychosocial factors related to individual occupants.
Night ventilation	In combination with daytime window opening algorithm OR night ventilation during specified cooling season.	No night ventilation, windows always closed at night.	<ul style="list-style-type: none"> - Provision of burglary safe ventilation openings - Potential collaboration with insurance companies
Lighting control	Light switching according to daylight availability, i.e. set point 500 lux (or 300 for computer tasks)	Light switched on throughout the working day	<ul style="list-style-type: none"> - Consider occupancy sensors for large spaces with room related lighting (auto off) - Provide individual controls, i.e. switches/dimming where

			possible
Blind control	Blinds closed due to glare (DGI threshold)' OR 'solar radiation on the façade + room temperatures above a defined threshold '.	Blinds closed throughout the working day.	<ul style="list-style-type: none"> - Design spaces that provide a degree of privacy - Prefer shading systems which allow for daylight penetration when activated - Consider separate systems for heat or glare protection

References

Ackerly, K., Baker, L., Brager, G. (2011): *Window use in mixed mode buildings: a literature review*, Center for the Built Environment Berkeley, Summary report: Occupant control of windows, April 2011

Bordass, B., Bromley, K., and Leaman, A., 1993. *User and occupant controls in office buildings*. BRE Research Report in Building Services.

Boubekri, M. and Boyer, L.L., 1992. Effect of window size and sunlight presence on glare. *Lighting Research and Technology*, 24 (2), 69–74.

Bourgeois, D.J., 2005. Modelling occupants and behaviour in building energy simulation. *Collection Mémoires et thèses électroniques*, Université Laval, Quebec.

Bulow-Hube, H., 2000. Office worker preferences of exterior shading devices: a pilot study. *EuroSun 2000*, June 19–22, Copenhagen, Denmark.

Burak Gunay, H., O'Brien, W., Beausoleil-Morrison, I. (2013): A critical review of observation studies, modeling, and simulation of adaptive occupant behaviors in offices, *Building and Environment*, Volume 70, Pages 31-47

EU Energy Star http://www.eu-energystar.org/en/en_008.shtml

Galasiu, A.D. and Veitch, J.A., 2006. Occupant preferences and satisfaction with the luminous environment and control systems in daylight offices: a literature review. *Energy and Buildings*, 38 (7), 728–742.

Hopkinson, R.G. 1970. Glare from Windows. *Construction Research and Development Journal* 2, 98.

Hopkinson, R.G. 1972. Glare from Daylighting in Buildings. *Applied Ergonomics* 3, 206.

Inkarojrit, V., 2005. *Balancing comfort: occupants' control of window blinds in private offices*. Thesis (PhD). University of California, Berkeley.

Moore, T., Carter, D.J., and Slater, A.L., 2003. Long term patterns of use of occupant controlled office lighting. *Lighting Research and Technology*, 35 (1), 43–59.

Newsham, G.R., 1994. *Manual control of window blinds and electric lighting: implications for comfort and energy consumption*. National Research Council Canada, NRCC–37021.

- Osterhaus, W., 2008. Analysis of luminance histograms for the assessment of discomfort glare in daylight offices. Balkan Light Conference, 7–10 October 2008, Ljubljana.
- Rea, M.S., 1984. Window Blind occlusion: a pilot study. *Building and Environment*, 19 (2), 133–137.
- Reinhart, C.F. and Voss, K., 2003. Monitoring manual control of electric lighting and blinds. National Research Council Canada. Available from: <http://irc.nrc-cnrc.gc.ca/ircpubs> [Accessed 2 March 2011].
- Rijal, H.B., et al., 2008. Development of an adaptive window-opening algorithm to predict the thermal comfort, energy use and overheating in buildings. *Journal of Building Performance Simulation*, 1 (1), 17–30.
- Roetzel, A., Tsangrassoulis, A., Dietrich, U., Busching, S. (2009): A review of occupant control on natural ventilation, “renewable and sustainable energy reviews”, Volume 14, Issue 3, April 2010, Pages 1001-1013
- Roetzel, A., Tsangrassoulis, A., Dietrich, U., Busching, S. (2011): Context dependency of comfort and energy performance in mixed mode offices, *Journal of Building Performance Simulation*, Special Issue: Modelling Occupants' Presence and Behaviour – Part I, Volume 4, Issue 4, pp. 303-322
- Rubinstein, F., et al., 2003. Analyzing occupancy profiles from a lighting controls field study. Lawrence Berkeley National Laboratory paper, LBNL 52344.
- Sutter, Y., Mumortier, D., and Fontoynt, M., 2006. The use of shading systems in VDU task offices: a pilot study. *Energy and Buildings*, 38(7), 780–789
- Tuaycharoen, N. and Tregenza, P.R., 2007. View and discomfort glare from windows. *Lighting Research and Technology*, 39 (2), 185–200.

Exergetic Review on Thermal Performance of Window Systems

Masanori Shukuya¹

¹ Department of Restoration Ecology and Built Environment, Tokyo City University, Japan, shukuya@tcu.ac.jp

Abstract

According to an advancement of exergy research in relations to thermal comfort and built environment for the last fifteen years, the availability of “warm” or “cool” radiant exergy emitted by the interior surfaces of building envelope systems is crucially important in providing building occupants with adaptive opportunity for thermal comfort both in summer and in winter. This paper demonstrates some numerical examples showing how the thermal performance of window systems affects the availability of “warm” and “cool” radiant exergies. In winter, thermal insulation of window systems together with appropriate internal solar control brings about ten to twenty times larger “warm” radiant exergy, while in summer external shading of window systems reduces “warm” radiant-exergy emission towards the indoor environment by more than 80% comparing to internal shading device, and allows the built environmental space to be filled with “cool” radiant exergy emitted by other interior surfaces of building envelopes.

Keywords: Warm and cool exergies, long-wavelength radiation, solar radiation, shading devices, emission

1 Introduction

The evaluation of indoor thermal environment in relations to thermal comfort of building occupants and also the estimation of the amount of fossil fuels for running space heating and cooling systems are usually made with the concept of energy, that is the first law of thermodynamics. They allow us to learn much, but it is not sufficient because of providing us with nothing about what we should learn from the second law of thermodynamics.

Over the last fifteen years or so, concerned building scientists, architects, and engineers have gradually recognized the importance of low-temperature heating and high-temperature cooling systems, which should be successful with a full use of advanced passive-system technology together with reformed and hence advanced active-system technology.

The performance of such systems and also their resultant built environment can be well evaluated with the concept of “exergy”, which is derived from both, the first and the second laws of thermodynamics, together with the concept of environmental temperature for a system in focus. This is, I think, probably very much associated with the adaptive physio-psychological characteristics of human being (Shukuya, 2013).

In this paper, the exergetic characteristics of window systems as part of building envelope systems are demonstrated and thereby reviewed in order to confirm what is required in the pursuit of low-exergy system solutions, with which adaptive opportunity for thermal comfort should be more easily available.

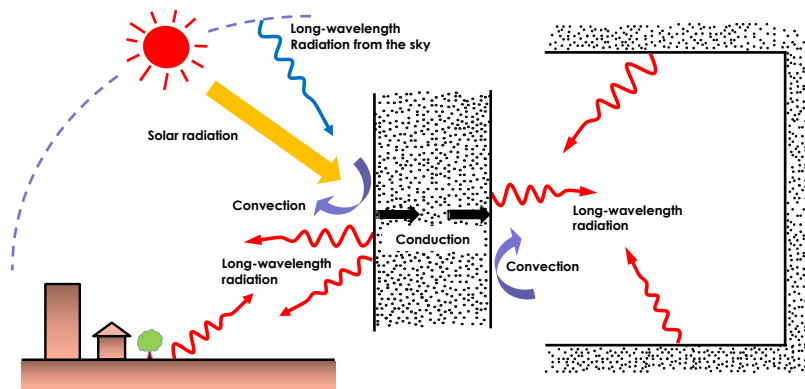

Figure 1. Thermal exergy transfer within an external wall by long-wavelength radiation, convection, and conduction. Solar exergy transfer is by short-wavelength radiation.

2 Warm and cool exergy transfer within the built environment

As schematically presented in **Figure 1.**, solar radiation, that is a kind of short-wavelength radiation, absorbed by the wall surface may cause the rise of surface temperature and thereby as its consequence the wall surface may emit thermal exergy by long-wavelength radiation. All of the adjacent surfaces of other building walls, the sky, and the pavement surface may also emit thermal exergy by radiation whose portion is absorbed by the wall surfaces. The same phenomenon apply to the room space surrounded by interior surfaces of wall, ceiling and floor.

Wind blowing along the exterior side of the wall sweeps away some amount of thermal exergy by convection. Along the interior surface of the wall, there is usually not such movement of air as strong as wind outdoors, but there is always a subtle movement of air upwards or downwards due to buoyancy caused by temperature difference between the interior surfaces of walls and room air in their respective vicinities.

Such thermal exergy transfer by radiation and convection outdoors and indoors influences on the variation of external and internal surface temperatures, but the conduction of thermal exergy inside wall and windows does also influence on the variation of external and internal surface temperatures.

In short, there are always three types of thermal exergy transfer: thermal radiation; convection; and conduction. Understanding of their exergetic characteristics is essential in order to plan, design, and realize low-exergy systems for human thermal health and comfort to be sought in the built environment.

2.1 Exergy balance equation

As we all know by our everyday experience, the absorption of solar radiation by materials yields “warmth”. One example is that we feel “warmth” or “hotness” in particular if we wear a dark-coloured shirt or sweater, when we are outdoors under a sunny condition. Another example is that you feel “warmth” by touching a part of floor or wall surface, on which solar radiation transmitting through the nearby windows is incident. In these cases, a portion of solar exergy is necessarily absorbed, consumed, and thereby “warm” exergy is generated.

We can set up an exergy balance equation for a system that absorbs solar radiation. Let us focus on the innermost layer of a window system, as shown in **Figure 2.**, as a thermodynamic system. We assume that the layer is infinitely thin so that we neglect

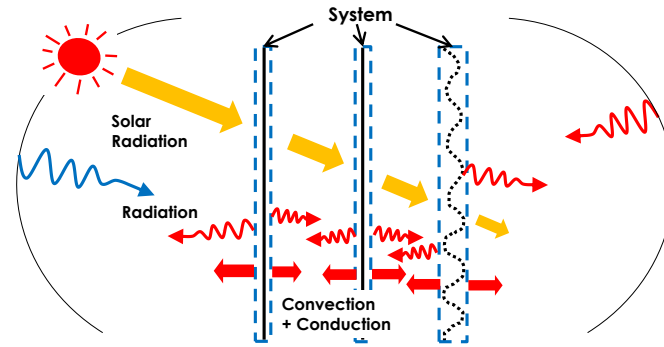

Figure 2. Window system consisting of three layers. Each of the layers can be regarded as a thermodynamic system. Whether a system assumed is opaque, transparent, or translucent, some amount of solar exergy is absorbed, consumed, and thereby thermal exergy is transferred to the surrounding space either by the emission of long-wavelength radiation, by conduction, or by convection. The system also absorbs thermal radiant exergy coming from surrounding surfaces.

the heat capacity. Then, the exergy balance equation can be set up in general as follows, assuming that thermal exergy transfer by convection and conduction are from the system to the surrounding space.

$$\begin{aligned}
 & [\text{Solar exergy absorbed}] + [\text{Thermal radiant exergy absorbed}] \\
 & - [\text{Exergy consumed within the system}] \\
 & = [\text{Thermal radiant exergy emitted}] \\
 & \quad + [\text{Thermal exergy transferred by convection to the surrounding}] \\
 & \quad + [\text{Thermal exergy transferred by conduction to the surrounding}] \quad (1)
 \end{aligned}$$

2.2 Warm and cool radiant-exergy emission

Thermal radiant exergy emission rate from a surface, whose temperature is T_{isw} in the unit of Kelvin can be expressed by the following equation.

$$x_r = \varepsilon h_b \frac{(T_{isw} - T_o)^2}{T_{isw} + T_o}, \quad (2)$$

where ε is the surface emittance, h_b is radiative heat-transfer coefficient of blackbody [W/(m²·K)], and T_o is the environmental temperature in Kelvin. Due to the fact that $0 < \varepsilon$, $0 < h_b$, $0 < T_{isw} + T_o$, and $0 < (T_{isw} - T_o)^2$, the radiant exergy is necessarily larger than zero except a case that the surface temperature equals the environmental temperature. For the cases of $T_o < T_{isw}$, there is “warm” radiant exergy emission and for the cases of $T_{isw} < T_o$, there is “cool” radiant exergy emission.

In eq.(1), its first term of right-hand side is exactly calculated by eq.(2). The second term of left-hand side of eq.(1) is also calculated by eq.(2), but in this case T_{isw} is

replaced with the surrounding surface temperature, T_{rm} , and then the surface emittance being equal to absorptance is further multiplied to thermal radiant exergy given by eq.(2).

2.3 Warm and cool exergy transfer by convection

Let us focus on the boundary layer between the innermost layer and room air, as shown in **Figure 3**. We assume a case that room air temperature, T_{ia} , is higher than that of the innermost layer, T_{isw} . For this boundary layer, we can derive the following exergy balance equation.

$$x_{cv_ia} - x_c = x_{cv_isw}, \quad (3)$$

where x_{cv_ia} is the rate of exergy transferred from room air to the boundary layer [W/m^2], x_c is the exergy-consumption rate within the boundary layer [W/m^2], and x_{cv_isw} is the rate of exergy transferred into the innermost layer [W/m^2]. These three terms are expressed as follows.

$$x_{cv_ia} = h_{cv}(T_{ia} - T_{isw}) \left(1 - \frac{T_o}{T_{ia}} \right), \quad (4)$$

$$x_c = s_{gcv} \cdot T_o, \quad (5)$$

$$x_{cv_isw} = h_{cv}(T_{ia} - T_{isw}) \left(1 - \frac{T_o}{T_{isw}} \right), \quad (6)$$

where h_{cv} is convective heat-transfer coefficient [$\text{W}/(\text{m}^2\text{K})$] and s_{gcv} is the entropy generation rate [$\text{W}/(\text{K}\cdot\text{m}^2) = \text{Ons}/(\text{s}\cdot\text{m}^2)$].

Taking a look at both eqs.(4) and (6), the rate of exergy flow by convection can be either positive or negative depending on the relationships between three temperature values of T_o , T_{isw} , and T_{ia} . Because of three variables, there are six combinations, which are different in whether a given exergy value implies “warm” or “cool” and also in whether it implies “outgoing” or “incoming”.

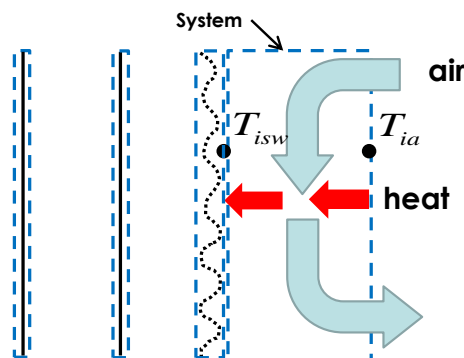

Figure 3. Heat transfer due to convection of room air taking place within the boundary layer adjacent to the innermost layer of a window system.

Table 1. Convective warm or cool exergy represented by eq.(4) flowing into the system of boundary layer near the innermost layer of window system

	Temperature	$a = T_{ia} - T_{isw}$	$b = 1 - \frac{T_o}{T_{ia}}$	$a \cdot b$	Warm/ Cool	In/ Out
I	$T_o \leq T_{isw} < T_{ia}$	+	+	+	Warm	In
II	$T_o < T_{ia} \leq T_{isw}$	-	+	-	Warm	Out
III	$T_{isw} < T_o \leq T_{ia}$	+	+	+	Warm	In
IV	$T_{ia} \leq T_o < T_{isw}$	-	-	+	Cool	In
V	$T_{isw} \leq T_{ia} < T_o$	+	-	-	Cool	Out
VI	$T_{ia} < T_{isw} \leq T_o$	-	-	+	Cool	In

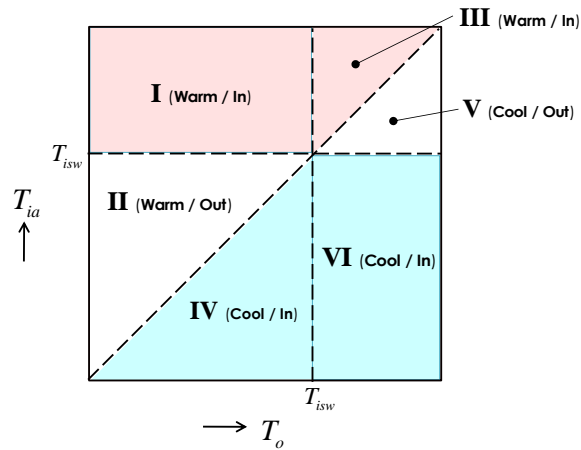

Table 1. shows these six combinations for the exergy flow of x_{cv_ia} given by eq.(4). In Table 1, the sign of Carnot factor denoted by b determines whether x_{cv_ia} is “warm” or “cool” exergy: positive is “warm” exergy and negative “cool” exergy. The other factor denoted by a is the difference in temperature between two surfaces and the sign of the product, $a \cdot b$, determines “inflow” or “outflow”: positive is inflow and negative outflow; that is, the former is towards the innermost layer of window system and the latter towards room space. The diagram attached to Table 1 shows respective six ranges determined by the combination of three temperatures, T_o , T_{isw} , and T_{ia} .

The same discussion as above applies to convective exergy-transfer calculation to be made by eq.(6) and also to conductive exergy-transfer calculation.

2.4 Exergy consumption due to solar radiant and thermal radiant exergies

The third term of left-hand side of eq.(1), [Exergy consumed within the system], in the case of innermost layer consists of two parts: one due to the absorption of solar

exergy and the other due to that of thermal radiant exergy given from the opposite interior surfaces of room space.

Focusing on the former, solar exergy absorption and consumption, we can set up the following exergy balance equation.

$$a_s \cdot x_{TV} - x_{c_sol} = x_{th}, \quad (7)$$

where

$$x_{TV} = I_{TV} - s_{TV} \cdot T_o, \quad (8)$$

$$x_{th} = \left(1 - \frac{T_o}{T_{isw}}\right) a_s \cdot I_{TV}, \quad (9)$$

where a_s is the solar absorptance of the layer; x_{TV} is the sum of direct- and diffuse-solar exergy rates incident on the surface of the layer; x_{c_sol} is the rate of solar-exergy consumption within the layer; x_{th} is the thermal exergy produced by the absorption of solar exergy, which turns out to flow out from the system either by long-wavelength radiation, by convection, or by conduction; I_{TV} and s_{TV} are the total of solar energy and entropy incident on the system, respectively; T_{isw} and T_o are the layer temperature and the environmental temperature, respectively, both in the unit of Kelvin.

Substituting eqs.(8) and (9) into eq.(7), the rate of solar exergy consumption, x_{c_sol} , can be expressed as follows.

$$x_{c_sol} = a_s \left(\frac{I_{TV}}{T_{isw}} - s_{TV} \right) \cdot T_o \quad (10)$$

Since the rate of exergy consumption is expressed as the product of the rate of entropy generation and the environmental temperature, the term multiplied by T_o is the rate of entropy generation. This is the product of solar absorptance and the difference between the outflow of thermal entropy from the system, that is either going into the adjacent layer or the surrounding space indoors, and the solar entropy to be absorbed by the system, that is the inflow of entropy to the system. The layer temperature, T_{isw} , is definitely much lower than the thermodynamic-solar temperature, which is about 4300 K, so that the entropy is necessarily generated by the absorption of solar radiation.

What has been described so far above can be exactly applied to other two layers shown in Figure 2., a transparent glass sheet as a part of double glazed window or to a system of a translucent shading device, which may be positioned either in the outdoor or indoor side of the window.

Substitution of the exact formulae for exergy transfer by radiation in the form of eq.(2), and convection and conduction in the form of eq.(4) or (6) and a little bit of algebraic operation of the resultant equation yields the following formula to give the exergy consumption rate at the interior surface of the innermost layer, x_{c_thrad} in the unit of W/m^2 , which is exactly due to the absorption of thermal radiant exergy by the innermost layer.

$$x_{c_thrad} = \varepsilon T_{isw}^3 \left\{ \frac{1}{3} + \left(\frac{T_{rm}}{T_{isw}} \right)^3 \left(\frac{T_{rm}}{T_{isw}} - \frac{4}{3} \right) \right\} T_o, \quad (11)$$

where T_{rm} is the mean radiant temperature of other walls surrounding the innermost layer, which is in the unit of Kelvin.

3 Numerical Examples

Figure 4. shows three cases of solar-exergy absorption and consumption together with thermal radiant exergy emission from and consumption at the innermost layer of the window and thermal exergy transferred by convection through the boundary air layer between the innermost layer of the window and the room air under a winter condition. Three cases of windows assumed are a) a single glass-paned window, b) a double-glazed window, and c) a double-glazed window having an internal shading device.

In order to calculate the numerical values of thermal exergy, we need to have the temperature of glass sheets and shading device. This was done by solving the

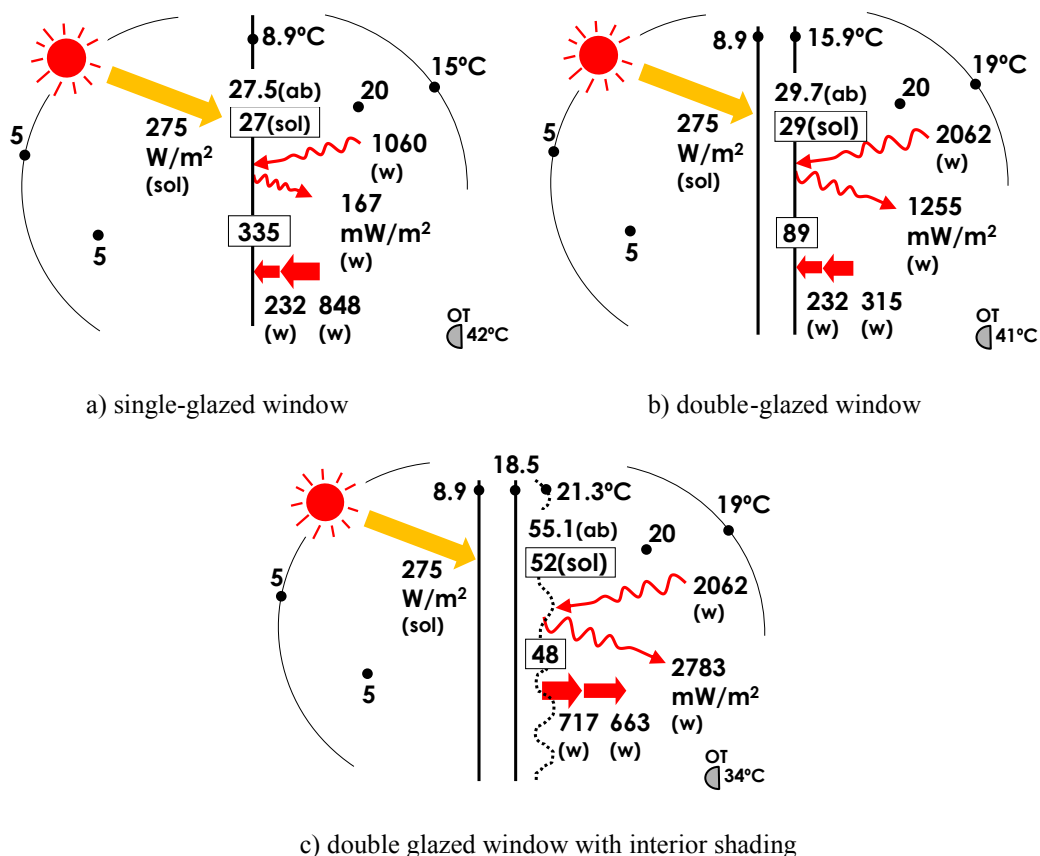

Figure 4. Solar exergy absorption and consumption together with thermal radiant exergy emission, consumption, and thermal exergy transferred by convection at the innermost layers of three windows in winter. The innermost layer of the third case is internal shading device having its solar transmittance of 0.5 and absorptance of 0.3. The values in the upper squares are solar exergy consumption rate and those just above are solar exergy absorbed. The values in respective lower squares are thermal radiant exergy consumption rate. Those values denoted by “w” in bracket below them are “warm” radiant exergy flow rate.

respective sets of energy balance equations with respect to the temperatures of glass sheets and shading device, assuming the heat-transfer coefficients and the optical properties of glass sheets and shading device. The glass sheets, assumed for the exergy calculation shown in Figure 4., are ordinary clear glass having the thickness of 5mm, whose solar transmittance and absorptance are 0.8 and 0.1. The internal shading device is assumed to have the solar transmittance and absorptance of 0.5 and 0.3. The values of heat-transfer coefficients around the shading device were taken from a database compiled by Shukuya(1993).

The total of solar exergy incident on the exterior surface of each of these windows is $275\text{W}/\text{m}^2$. In the case of the single-paned glass window, $27.5\text{W}/\text{m}^2$ is absorbed and its 99%, that is $27\text{W}/\text{m}^2$, is consumed. The rate of “warm” radiant exergy emission from the interior surface of the single glazed window, $167\text{mW}/\text{m}^2$, is very small compared to those in the cases of the other two windows, 1255 or $2783\text{mW}/\text{m}^2$, since the temperature of the glass sheet in the case of the single glazed window is very low. This also results in the thermal radiant exergy consumption rate in case a) being the largest, $335\text{mW}/\text{m}^2$, among the three cases. In other words, making the thermal radiant exergy consumption rate smaller by insulating the whole of window system results in making thermal radiant exergy emission larger. That is what can be seen in cases b) and c).

Three temperature values shown at the lower right corner of each drawing shows the equivalent operative temperature including the effect of solar radiation, which is equivalent to the black-surface temperature of a thick board of extremely low thermal conductivity. Among the three values of equivalent operative temperature, that in the case of the single-glazed window is the highest. This suggests that much of the incident solar radiation is transmitted through the window and results in raising the surface temperature of the floor or other internal walls.

The inside layer of the double-glazed window emits “warm” radiant exergy at a much larger rate, 7.5 times larger than the single glass paned window does. The internal shading device in the third case, does not necessarily decrease solar-exergy gain for passive solar heating with window openings. Instead, it becomes rather an effective radiant heating panel to emit “warm” radiant exergy towards the indoor space. The “warm” radiant exergy emitted from the internal shading device is 1.35 times larger than the transparent layer of glass sheet of the double-glazed window.

The largest solar-exergy consumption rate among the three cases is $52\text{W}/\text{m}^2$ at the interior shading device due to its solar absorptance higher than that of clear glass sheets. A larger exergy consumption rate within the system brings about a higher temperature of the system.

The operative temperature in the third case is the lowest among the three cases due to the internal shading device. In the other two cases, the amount of transmitted solar exergy is much larger than the third case, but it is consumed totally anyway at the floor surface and the internal wall surfaces.

With the internal shading device, “warm” exergy transferred by convection is not from the room space toward the window, but from the shading device into the room space; this helps increase the amount of warm exergy contained by room air.

The results of exergy calculation described above for winter conditions confirms that the installation of well-insulated glass windows provides the occupants with a larger emission of “warm” radiant exergy, which would lower the human-body exergy consumption rate as pointed out by Isawa and Shukuya(2013).

Figure 5. demonstrates three cases of solar-exergy absorption and consumption together with thermal radiant exergy emission from and consumption at the innermost layer of the window and thermal exergy transferred by convection through the boundary air layer under a summer condition. Three cases are a) the inside glass layer of a double-glazed window without shading device, b) the interior shading device placed

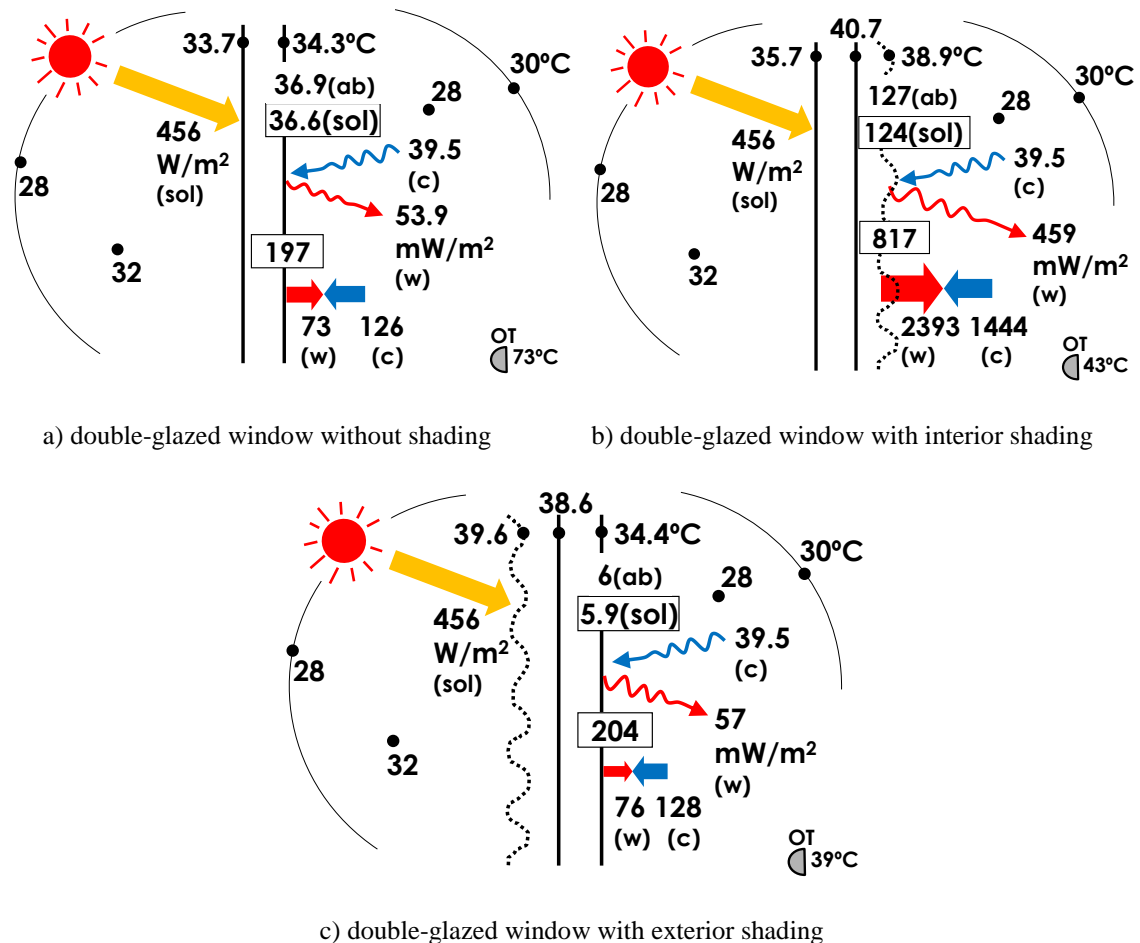

Figure 5. Solar exergy absorption and consumption together with thermal radiant exergy absorption, emission, consumption and thermal exergy transferred by convection at the innermost layers of three windows in summer. The innermost layer of the second case and the outermost layer of the third case are shading device having its solar transmittance of 0.15 and the solar absorptance of 0.4. The values in the upper squares are solar exergy consumption and those just above are solar exergy absorbed. The values in respective squares are thermal radiant exergy consumption rate. Those values denoted by either “w” or “c” in bracket below them are either “warm” or “cool” radiant exergy flow rate.

in the indoor side of a double-glazed window, and c) the inside glass layer of a double glazed window with exterior shading device.

The solar transmittance and absorptance of the shading device are assumed to be 0.15 and 0.4, respectively, in both the second and third cases. We here assumed a rather severe summer condition: the outdoor air temperature reaching 32°C together with the total of solar exergy incident on the vertical surface outside the three windows being 456W/m². Outdoor average radiant temperature was assumed to be 28°C, that is such a condition of sky temperature and ground temperature being 20°C and 36°C, respectively.

Without either interior or exterior shading device, “warm” radiant exergy emitted from the innermost layer of the window is the smallest among the three cases, but this results in the highest operative temperature of 73°C, which is 30 to 34°C higher than the operative temperature of the other two windows with shading devices. This means that the floor surface or interior wall surface temperatures are increased by solar-exergy consumption there and hence make the “warm” radiant exergy emission rate large.

The internal shading device causes a large rate of “warm” radiant exergy emission, since its temperature is increased up to 38.9°C due to a large rate of solar absorption and consumption. “Warm” exergy transferred from the surface of the internal shading device towards the room space is very large, while at the same time “cool” exergy transfer from the room air towards the internal shading device is also very large. This is because the convective heat-transfer coefficient tend to be large due to a large temperature difference between the room air and the interior shading device. A large rate of “warm” radiant exergy emission together with that of “warm” exergy transfer by convection results in a lot of “cool” exergy requirement and thereby necessitates a mechanical cooling system that requires a lot of exergy consumption to produce and supply “cool” exergy into the room space.

In case c) with exterior shading device, such a large rate of “warm” radiant exergy emission as that in the case with interior shading device occurs at the exterior shading device and most of the “warm” exergy generated is transferred outdoors by convection and radiation. The temperature of the innermost glass sheet in the third case, 34.4°C, is 4.5°C lower than that of the interior shading device in the second case, 38.9°C. This results in a much smaller rate of “warm” radiant exergy emission in the case of exterior shading device. That is 57mW/m², only 12% of the case of the interior shading device. This is also due to smaller thermal exergy consumption rate in the third case, only one-fourth of the second case.

Installation of the exterior shading device also decreases the “warm” exergy transfer by convection from the innermost surface of the glass sheet towards the room air and thereby results in a small “cool” exergy loss by convection from the room air. The rate of “cool” exergy from the room air into the boundary layer is 1444W/m² in the

case of the internal shading device, while on the other hand, it is 128W/m^2 , only 9% of the former.

4 Conclusion

This paper has demonstrated a state-of-the-art method of calculating exergy emission by thermal radiation, solar exergy absorption and consumption, and also exergy transfer by convection within window systems.

Numerical examples of solar-thermal exergy balance within the innermost layer of three window configurations both in winter and in summer reveal the following two major points:

- 1) In winter, appropriate thermal insulation of window systems to be provided mainly by passive-heating measures is important in increasing the emission rate of “warm” radiant exergy from the interior surface of windows;
- 2) In summer, installation of exterior shading devices is important in decreasing “warm” radiant exergy from the interior surface of windows, while at the same time in increasing the availability of “cool” radiant exergy within room space.

These measures are thus confirmed to be crucial in the pursuit of low-exergy system solutions, which must well contribute to allowing building occupants to have more adaptive opportunity for thermal comfort.

References

- Shukuya M., 1993. *Light and Heat in the Built Environment: an approach by numerical simulation*, Maruzen Publishers Ltd.(in Japanese)
- Shukuya, M., 2013. *Exergy: Theory and Applications in the Built Environment*. Springer-Verlag London.

Outdoor thermal condition and people's exposure time - A case study of cold climate

Mansoureh Tahbaz

School of Architecture and Urban Planning, Shahid Beheshti University, Tehran, Iran,
m58tahbaz@yahoo.com

Abstract

Outdoor thermal condition is one of the important factors for people's exposure time. This article is the results of a field study had been done in the mid winter 2010 – 2011 in Sheffield, UK. The aim is to find out the relationship between climatic condition, architectural design and peoples behavior. Two outdoor thermal indices that are appropriate for cold condition are used to explain the cold stress situation. To have the related information, the weather data is collected by a mobile Kestrel weather station that is designed for outdoor events. At the same time the people's behavior is observed according to different activities. Special attention is performed to disables, children and elders that are more sensitive to thermal condition. The results show that outdoor thermal indices such as UTCI (universal thermal climate index), WCET (wind chill equivalent temperature) and THI (Temperature Humidity Index) have not the same explanation for the same cold stress conditions. Other result is that people's outdoor exposure time is related to outdoor thermal situation but some psychological adaptation factors such as expectation and exciting condition will cause them to come out in spite of bad thermal situation. Architectural design will play an important role to modify thermal condition.

Keywords: outdoor thermal condition, thermal index, exposure time, psychological adaptation.

Introduction

Outdoor events in cold climates are completely related to thermal condition. Providing tolerable thermal condition is one of architects' responsibilities in design procedure. Outdoor thermal indices are introduced to help architects making appropriate decisions in design procedure. This article is trying to examine the accuracy of two main indices for cold stress condition that are Universal Temperature Climate Index (UTCI), Wind Chill Equivalent Temperature (WCET) and Temperature humidity index (THI) by field study. Micro analysis of people's behavior in outdoor spaces is used to find out the relation

between thermal condition and other personal factors that may affect people's behavior in cold conditions.

1- Research history

To help architects and designers for better decision making in design procedure, some thermal indices are provided for thermal prediction according to climatic condition. The first group of thermal outdoor indices is based on thermal stress model. Cold stress indices such as Wind chill Index (WCI) and Wind Chill Equivalent Temperature (WCET) are prepared for cold conditions. The second group of thermal outdoor indices are prepared base on heat budget model. They are capable to evaluate both cold and hot conditions such as Perceived Temperature (PT), Temperature Humidity Index (THI), and Universal Thermal Climate Index (UTCI).

1-1. Wind Chill Equivalent Temperature (WCET)

The wind chill equivalent temperature (also called the wind chill index, the wind chill factor, or just plain wind chill), is the temperature required under no-wind conditions that will equal the cooling effect of the air (the actual air temperature) and the wind on an average size, nude person in the shade. Moisture content of the air, visible moisture on the skin or clothing, presence of sunshine, clothing, and physical activity are not considered (Osczevski & Bluestein, 2005; Aerographer/Meteorology, 2008).

NOAA, National Weather Service of USA website has provided an online calculator for new wind chill index (NOAA, 2013 December) (Equation 1)

$$\text{New Wind chill Index} = 13.12 + 0.6215 T - 11.37 (V^{0.16}) + 0.365 T (V^{0.16}) \quad (\text{Equation 1})$$

Where V = wind speed (km/h) and T = temperature (Celsius). Winds need to be above 4.8 km/hr and below 177 km/hr. Temperatures need be to above -50°C and below 10°C.

The wind chill index does not take into account the effect of sunshine. Bright sunshine may reduce the effect of wind chill (make it feel warmer) by 6 to 10 units. Bright sunshine can make you feel as much as ten degrees warmer (Shitzer, 2007). Online calculation for WCET is done according to different wind speeds (Tahbaz, 2011). The hazardous WCET (-25°C and -35°C) is calculated for important limits of wind speed such as 1.4 m/s and 5 m/s (10 m/s gust), that are the lowest and highest acceptable wind speed in urban spaces respectively (Table 1).

Table 1. Air temperature calculation for WCET thermal zones (Tahbaz, 2011)

WCET	Thermal sensation
-10 to 0	low cold stress
-25 to -10	moderate cold stress
-35 to -25	heavy cold stress
Less than -35	extreme cold stress

air temp C	wind speed (km/h)		
	5	18	38
WCET	wind speed (m/s)		
	1.4	5	10
0	1	4	5
-10	-7	-4	-2
-25	-21	-16	-13.5
-35	-29.5	-24	-21

1-2. Universal Thermal Climate Index (UTCI)

Some of outdoor indices are prepared base on heat budget model. They are capable to evaluate both cold and hot conditions such. The Universal Thermal Climate Index (UTCI)¹ is one of these indices that provide an assessment of outdoor thermal environment in bio-meteorological applications based on the equivalence of the dynamic physiological response predicted by a model of human thermoregulation, which was coupled with a state-of-the-art clothing model (Bröde, et al., 2010). The purpose of the Universal Thermal Climate Index (UTCI) is to inform the public of how the weather feels, taking into account factors such as wind, radiation and humidity. In order to help the general public to relate directly to the UCTI, it is proposed that this index should be on the temperature scale (e.g. in degrees Celsius) (Richards & Havenith, 2007; COSTAction730, n.d.). The operational procedure, which is available as software from the UTCI website (Wojtach, 2014), showed plausible responses to the influence of humidity and heat radiation in the heat, as well as to wind speed in the cold and was in good agreement with the assessment of ergonomics standards concerned with the thermal environment.

UTCI will be calculated online at <http://www.utci.org/utcineu/utcineu.php> (Wojtach, 2014). It takes into account all climatic factors: air temperature ($-40^{\circ}\text{C} < T_a < +45^{\circ}\text{C}$), mean radiant temperature ($-10\text{K} < T_{\text{mrt}} - T_a < +40\text{K}$), relative humidity ($5\% < \text{rh} < 95\%$),

¹ - The UTCI is the completion of another index called Perceived Temperature (PT). The perceived temperature PT in the dimension °C is the air temperature of a reference environment in which the perception of heat and/or cold would be the same as under the actual conditions (Staiger, et al., 1997; Jendritzky, et al., 2000). In the reference environment the wind velocity is reduced to a slight draught, and the mean radiant temperature is equal to the air temperature (for example, an extensive forest). The water vapor pressure is identical with the actual environment as far as it is not reduced by condensation (Jendritzky, 2002). Perceived heat and cold is computed by means of the comfort equation by Fanger (1970) which is based on a complete heat budget model of the human body (Fanger, 1970).

wind speed ($1.1 < V_r < 17.6$ m/s) and human factor of cloth insulation ($0.4 < clo < 2.6$) and activity of walking 4 km/h (2.3 MET or 135 W/m^2) (Jendritzky, 2004).

Table 2 shows the thermal zone categories of UTCI. Using the formula of UTCI and above categories the main thermal zones for outdoor spaces is drawn on psychrometric chart (Fig 2).

Table 2. UTCI thermal categories (Bröde, et al., 2010)

UTCI C°	Thermal category
bellow - 40	Extreme cold stress
- 40 to - 27	Very strong cold stress
- 27 to -13	Strong cold stress
- 13 to 0	Moderate cold stress
0 to + 9	Slight cold stress
+ 9 to +26	No thermal stress
+ 26 to + 32	Moderate heat stress
+ 32 to + 38	Strong heat stress
+ 38 to + 46	Very strong heat stress
above + 46	Extreme heat stress

1-3. Temperature Humidity Index (THI)

Temperature Humidity index (THI) is another index that takes into account wet and dry bulb temperature. It was developed by Thom 1959 and can be applied to locations that are both shaded and protected from the wind (Thom, 1959; Yilmaz, et al., 2007). Although THI is used originally to determine the discomfort due to heat stress, it has been extended over a wider range of conditions that refers to cold stress. The optimum of THI occurs between 15°C and 20°C , and that is the basis for defining comfortable conditions. Below a THI of 15°C , evaporation takes away heat from the body thus requiring defense against cooling and increasing thermogenic mechanisms are required to combat increasing cold stress. The THI is secured by a simple linear adjustment applied to the average of the simultaneous dry-bulb and wet-bulb temperature (Unger, 1999). The equation 2 for THI using air temperature (t) and humidity (f) is: [39]

$$\text{THI } (^\circ\text{C}) = t - (0.55 - 0.0055f)(t - 14.5) \quad (\text{Equation 2})$$

Where t = air temperature measured in degrees Celsius and f = the relative humidity (Unger, 1999). The thermal categories of the THI are defined as table 3.

Table 3. THI thermal categories (Kyle, 1994)

THI C°	Thermal category
bellow – 40	Hyperglacial
– 39.9 to – 20	Glacial
– 19.9 to –10	Extremely cold
– 9.9 to – 1.8	Very cold
– 1.7 to + 12.9	Cold
+ 13 to +14.9	Cool
+ 15 to + 19.9	Comfortable
+ 20 to + 26.4	Hot
+ 26.5 to + 29.9	Very hot
above + 30	Torrid

2- Research Method

To be able to work with these indices and have a comparison opportunity, the thermal zones in Table 1,2 and 3 are converted on psychrometric chart. Using these psychrometric charts, the collected microclimate data of the field study in the cold city of Sheffield in UK could be interpreted related to outdoor thermal condition.

2-1. Humidity, Air Movement and Sunshine Effect in cold Condition

In cold conditions air movement has a great effect on thermal sensation. By increasing the air speed in temperatures less than 5°C the chill wind effect happens and lowers the effective temperature². If clothing were to get wet, the cooling effect would be greater than that predicted by WCET model and the chance of hypothermia would be greater. Fig 1 shows that by increasing the air speed from 1.4m/s to 5 m/s (10 m/s gust), the thermal zone will lower one level.

Sunshine, even in a cold winter day, can make a difference in the thermal sensation. Bright sunshine can make person feels as 6-10°C warmer as advised in the "new" wind chill chart (NWS USA, 2001; Environment-Canada, 2001). The effect of sunshine is much more pronounced at low wind speeds and gradually diminishes as wind speed intensifies and its effects become dominant (Shitzer, 2007).

In wet, windy conditions, someone wearing inadequate clothing can become hypothermic in quite mild temperatures (Heat-Stress, 2008). Activity is an important factor in such conditions. This can be very important because when there is high clothing insulation the range of metabolic rates which are within the band between sweating and shivering is reduced so there is a danger of sweating and creating thermal bridges in the clothing.

² - Effective temperature is a comfort index or scale that takes into account the temperature of air, its moisture content, and movement (Medical Dictionary, 2002).

Unfortunately none of the indices related to cold conditions, did study the relation between high activity levels and clothing. Fig 1, 2, 3 and 4 shows cold stress thermal zones of WCET (Wind Chill Equivalent Temperature), UTCI (Universal Thermal Climate Index), THI (Temperature Humidity Index) and PT (Perceived Temperature)³ respectively.

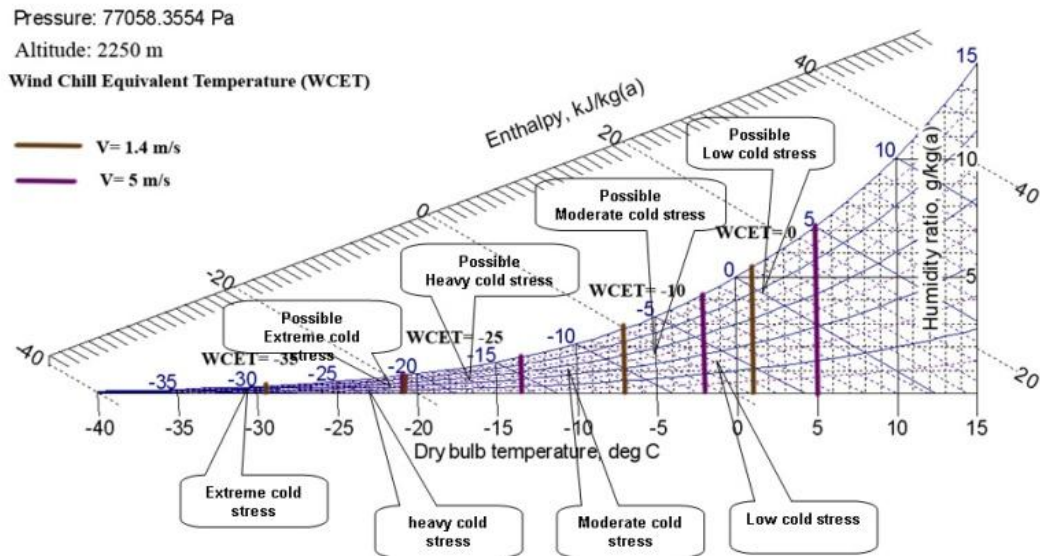

Figure 1. WCET Index - Effect of wind speed on thermal zones on psychrometric chart in low temperatures (Tahbaz, 2011)

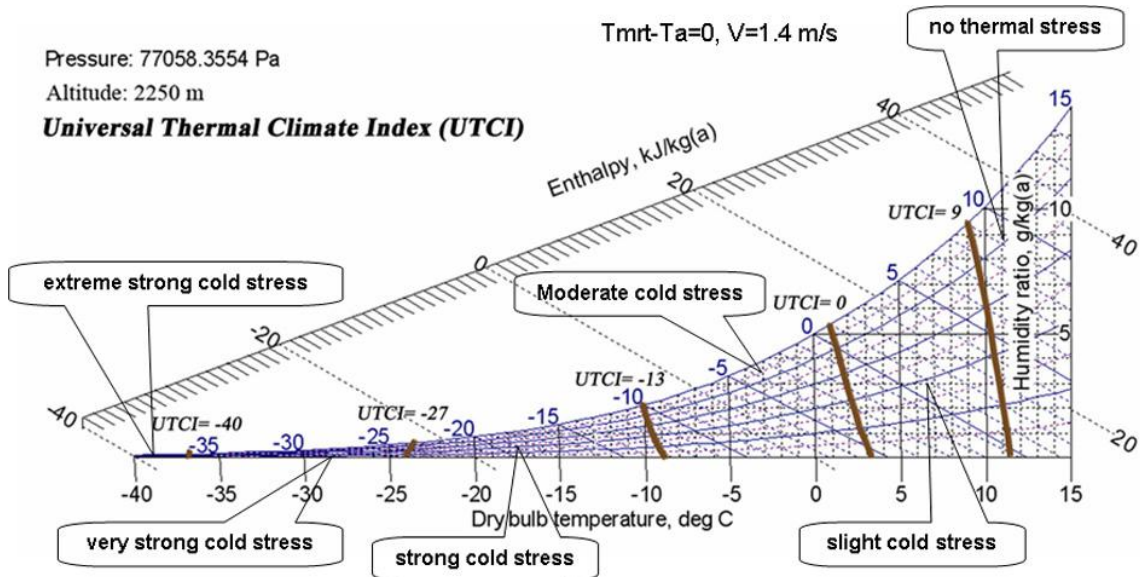

Figure 2. UTCI - Thermal zones on psychrometric chart in cold condition (Tahbaz, 2011)

³ - Although perceived temperature is no longer in use, here it is compared with other indices in cold condition to show its differences.

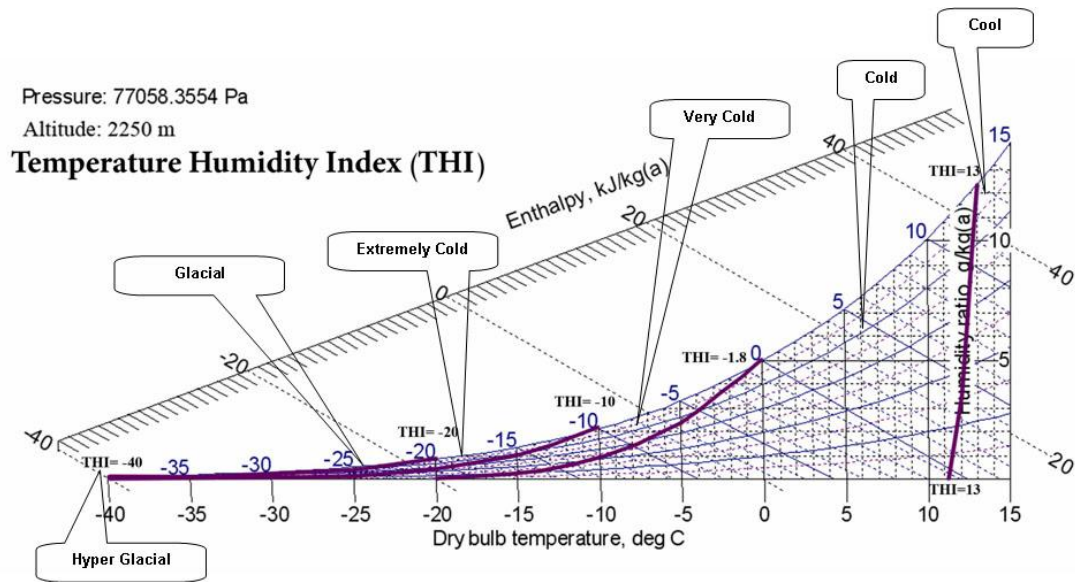

Figure 3. THI Index - effect of humidity on thermal zones on psychrometric chart in low temperatures (Tahbaz, 2011)

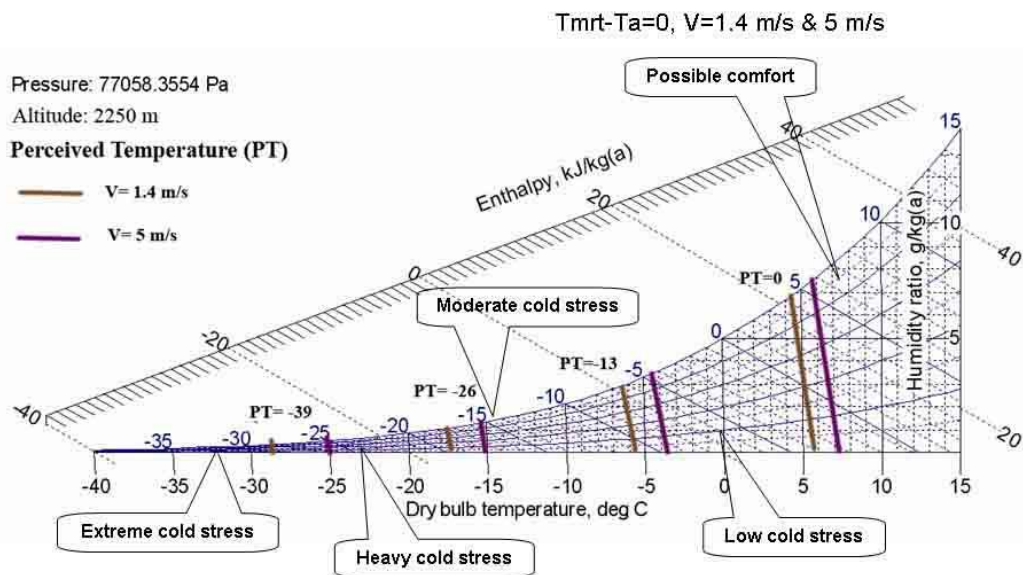

Figure 4. PT (Perceived Temperature) - Effect of wind speed on thermal zones on psychrometric chart in low temperatures (Tahbaz, 2011)

2-2- The Method of the Field data collection

Microclimate field data are collected in the critical cold condition of the year (midwinter), in populous pedestrian walkways in the city center of Sheffield. The important places in the way such as outdoor coffee shops or restaurants, public building entrance or plaza, passages and walkways are chosen as the point of data collection.

The field data are collected by a mobile Kestrel personal weather station data logger WS-4500 (Fig 5) that is able to collect the data of several meteorological elements such as temperature, humidity, wind speed, biometric pressure, altitude and an internal compass to indicate magnetic north of the observed location⁴. The range and accuracy of the data elements are shown in the right side of Fig 5. This instrument is capable to be used for weather monitoring for mountaineering or other outdoor events that climatic conditions play a major role (Kestrel-catalog).

One Kestrel is fixed in a place collects data each 30 minutes as a reference point to represent the local climate. Another Kestrel is moving in the path of observation collects data each 30 seconds to show the microclimate changes in different outdoor places. Using outdoor thermal indices to interpret these data, the thermal condition of observed places are defined on psychrometric chart provided for each index (Fig 1, 2, 3 and 4). Sikron software (Tahbaz & Amini Behbahani, 2011) is used to accelerate the process of data transfer to psychrometric chart.

Manufacturer	Model	Price*	Wind Speed (mph)	Wind Direction (°)	Outdoor Temperature (°F)	Indoor Temperature (°F)	Outdoor Humidity (%)	Indoor Humidity (%)	Barometric Pressure (inHg)
Kestrel Instruments	WS-4500-KIT [®] 4500 Portable Weather Station Kit	\$308.90	Range: 0-135	Resolution: 22.5°	Range: -40 - 257	Resolution: 0.1	Range: 0 - 100%	Resolution: 0.02 inHg	Range: 0.3 to 32.5
	WS-4500NVTAN-KIT [®] 4500NVTAN Portable Weather Station Kit	\$368.90	Resolution: 0.1	Accuracy: ± 3%	Accuracy: ± 5°	Accuracy: ± 2.0 °F	Accuracy: ± 3%	Accuracy: ± 0.05 inHg	
	WS-4500NV-KIT [®] 4500NV Portable Weather Station Kit	\$368.90							



Figure 5. Kestrel portable weather station data logger WS-4500 (Kestrel-catalog)

People's behaviour in different thermal condition, is recorded by taking appropriate photos. Special attention is paid to the children, elderly and disables as the most sensitive people to thermal condition. Behavior is identified by clothes, activities, foods and length of exposure time in each condition. Comparison between people's behavior and thermal condition predicted by outdoor indices will help to determine two subjects. One is the definition of thermal cold stress according to people outdoor behavior, second is the validity of each index to define the thermal condition.

To control the intervening factors affecting the observation method, the collected data of moving Kestrel weather station as the microclimate representative, is compared with three other climate data in three levels: 1- the meteorology data of the city in a long term period as the representative of the meso-climate, 2- the meteorology data of the observation days as the representative of the city climate, 3- the collected data of the reference point (the fixed Kestrel weather station) as the representative of the local climate. Comparing the long term meteorology data with the weather data of the chosen days will show the condition of the observation days as ordinary, cold or hot days. Comparing the weather data of the observation days (city short term climate) with the

⁴ - The accuracy of each of its primary measurements was individually calibrated and tested against standards traceable to the National Institute of standards and Technology (NIST) or calibrated intermediary standards (Certificate of Conformity).

data of reference point will show the changes of the local climate according to the urban construction. Comparing the data of the reference point with the data of the observation points (moving Kestrel weather station) will show the microclimate changes according to the architectural design of the outdoor public spaces.

Constructed condition of the observed palaces is considered as the modifier of the local and microclimate situation by providing appropriate sunshade or sunlit place, leeward or windward place. These conditions will show the thermal modification ability of the architectural design.

3- Field study

To have a wide knowledge of climate condition of the case study city a brief explanation of its climatic condition is provided.

Sheffield in United Kingdom is located at 53°23'N 1°28'W. It is a geographically diverse city nestles in a natural amphitheatre created by several hills and the confluence of five rivers. The city's lowest point is just 29 meters above sea level near Blackburn Meadows, while some parts of the city are at over 500 meters. However, 79% of the housing in the city is between 100 and 200 meters above sea level. The climate in Sheffield is generally temperate. The Pennines range of mountains and hills to the west of the city can create a cool, gloomy and wet environment, but they also provide shelter from the prevailing westerly winds, casting a "rain shadow" across the area. Between 1971 and 2000 Sheffield averaged 824.7 millimeters of rain per year; December was the wettest month with 91.9 millimeters and July the driest with 51.0 millimeters. July was also the hottest month, with an average maximum temperature of 20.8°C. The average minimum temperature in January and February was 1.6°C. Since 1960, the temperature has never fallen below -9.2°C (wiki/Sheffield, 2014). Table 3 shows the conventional climatic condition of the city in long term period from 1981-2010.

Table 4. Sheffield long term climate data (MetOffice, 1981-2010; wiki/Sheffield, 2014)

Climate data for Sheffield 131m (430 ft) asl, 1981–2010, extremes 1960–													
Month	Jan	Feb	Mar	Apr	May	Jun	Jul	Aug	Sep	Oct	Nov	Dec	Year
Record high °C (°F)	13.9 (57)	17.6 (63.7)	23.3 (73.9)	24.8 (76.6)	27.8 (82)	30.7 (87.3)	31.8 (89.2)	34.3 (93.7)	27.4 (81.3)	24.1 (75.4)	17.6 (63.7)	15.0 (59)	34.3 (93.7)
Average high °C (°F)	6.8 (44.2)	7.1 (44.8)	9.8 (49.6)	12.5 (54.5)	16.1 (61)	18.8 (65.8)	21.1 (70)	20.6 (69.1)	17.7 (63.9)	13.5 (56.3)	9.5 (49.1)	6.9 (44.4)	13.4 (56.1)
Average low °C (°F)	1.9 (35.4)	1.7 (35.1)	3.3 (37.9)	4.8 (40.6)	7.5 (45.5)	10.5 (50.9)	12.7 (54.9)	12.4 (54.3)	10.3 (50.5)	7.5 (45.5)	4.5 (40.1)	2.3 (36.1)	6.6 (43.9)
Record low °C (°F)	-9.2 (15.4)	-8.3 (17.1)	-6.5 (20.3)	-3.9 (25)	-0.7 (30.7)	1.4 (34.5)	3.9 (39)	4.2 (39.6)	1.9 (35.4)	-4.1 (24.6)	-6.2 (20.8)	-9.1 (15.6)	-9.2 (15.4)
Precipitation mm (inches)	83.4 (3.283)	60.4 (2.378)	63.4 (2.496)	65.5 (2.579)	53.8 (2.118)	75.6 (2.976)	56.0 (2.205)	65.3 (2.571)	63.8 (2.512)	81.2 (3.197)	79.4 (3.126)	86.7 (3.413)	834.6 (32.858)
Avg. rainy days (≥ 1.0 mm)	13.4	10.5	12.3	10.3	9.6	9.1	9.2	9.9	8.9	12.7	12.6	13.0	131.6
Mean monthly sunshine hours	45.2	68.3	111.9	144.0	190.9	179.5	199.5	185.0	136.2	90.7	53.7	40.0	1,444.9
Source #1: Met Office ^[38]													
Source #2: Royal Netherlands Meteorological Institute ^[43]													

3-1- Meso and local climate in the days of observation

To show the thermal situation of the city according to outdoor thermal indices, the psychrometric charts of outdoor indices are generated by SIKRON software (Tahbaz &

Amini Behbahani, 2011) and Weather Data of Sheffield available at EnergyPlus website (EnergyPlus, 2014) is drawn as pshchrometric and table calendar climatic needs.

SIKRON software helps to show thermal condition on each index according to main heat or cold stress zones. Rainbow colors are chosen to show ocular outdoor thermal condition. Red colors refer to “extreme” and “very strong” heat stress⁵ that may cause “heat stroke”⁶. Orange and yellow colors refer to “strong” and “moderate” heat stress that may cause “heat exhaustion”⁷. Green colors refer to “no thermal stress”. It means that long term exposure⁸ in outdoor is tolerable or pleasant. Light blue colors refer to “slight” cold stress⁹ that will feel cool. Dark blue, light and dark purple colors refer to “moderate cold stress”, “strong”, “very strong” and “extreme cold stress” that may cause “hypothermia”¹⁰ and “frostbite”¹¹. Thermal conditions are distinguished visually and easily by using these colors. Fig 6 shows the charts’ legend. Fig 7 shows the long term hourly climate condition of Sheffield on UTCI index.

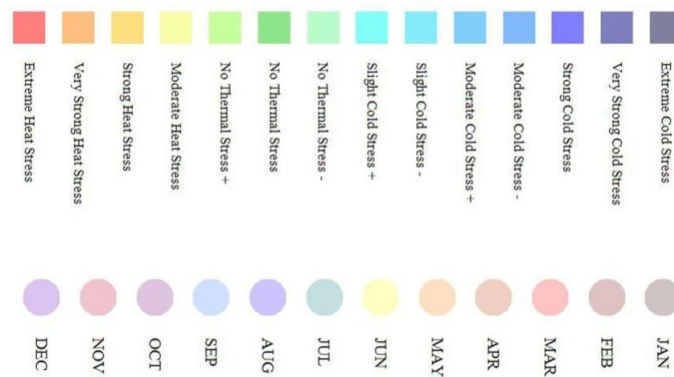

Figure 6. chart legend to show the thermal condition and month (SIKRON software)

⁵ - Heat stress: The physiological strain caused by an increase in core body temperature above safe levels where the individual is at risk of overheating (CasellaCel, 2014).

⁶⁶ - Heat stroke - Defined by a body temperature of greater than 40.6 °C (105.1 °F) due to environmental heat exposure with lack of thermoregulation. Symptoms include dry skin, rapid, strong pulse and dizziness (OSHA, 2008; Heat_stroke, 2014).

⁷ - Heat exhaustion - Can be a precursor of heatstroke; the symptoms include heavy sweating, rapid breathing and a fast, weak pulse (OSHA, 2008; Heat_illness, 2014).

⁸ - Heat exposure limits are based on some set of assumed physiological, personal, and environmental conditions (CasellaCel, 2014).

⁹ - Cold strain disorders include hypothermia (abnormally low body temperature) and frostbite (CasellaCel, 2014)

¹⁰ - Hypothermia is defined as a core temperature of the body less than 35 degrees Celsius (cold stress (CDC, 2014).

¹¹ - Frostbite is the freezing of some part of the body. Fingers, toes, and even whole arms and legs can be lost as a result of frostbite (CDC, 2014). At or below 0 °C (32 °F), blood vessels close to the skin start to constrict, and blood is shunted away from the extremities via the action of glomus bodies. The same response may also be a result of exposure to high winds (Frostbite, 2014).

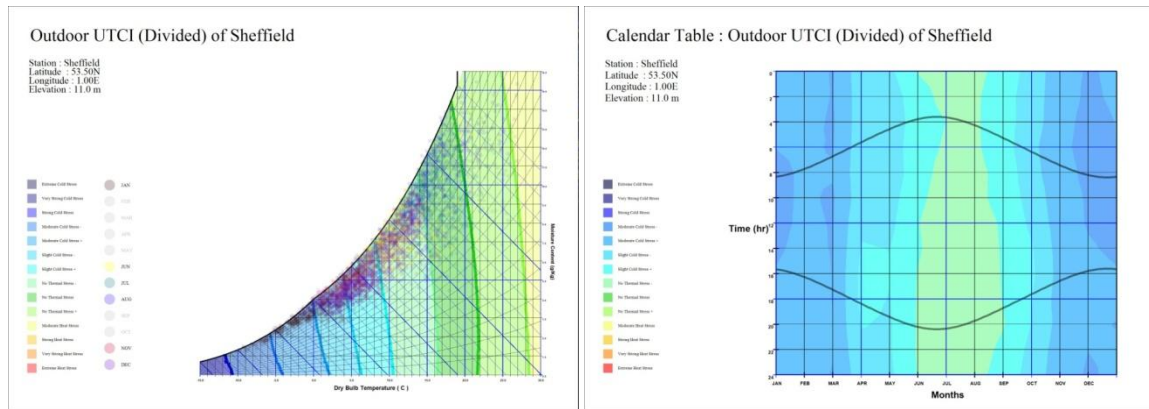

Figure 7. long term hourly data of Sheffield on UTCI index (SIKRON software)

3-2- Field data collection

Field study observations were done in the fall and winter 2010-2011 in Sheffield to examine the thermal definition of different outdoor indices in real condition. The study shows the local people's reaction to cold weather. The results will help to clarify which of the outdoor indices is more appropriate for cold climate.

To compare the short term and the long term weather data of the city, the hourly data of the meteorology station of the observed days, and the local data gathered by Kestrel weather station are compared with the average data of long term meteorology on psychrometric chart of UTCI index. Fig 8 shows that in the observation days of 2010-2011 in Sheffield at daytime the weather is warmer and dryer than ordinary winter days, at night it is a little dryer.

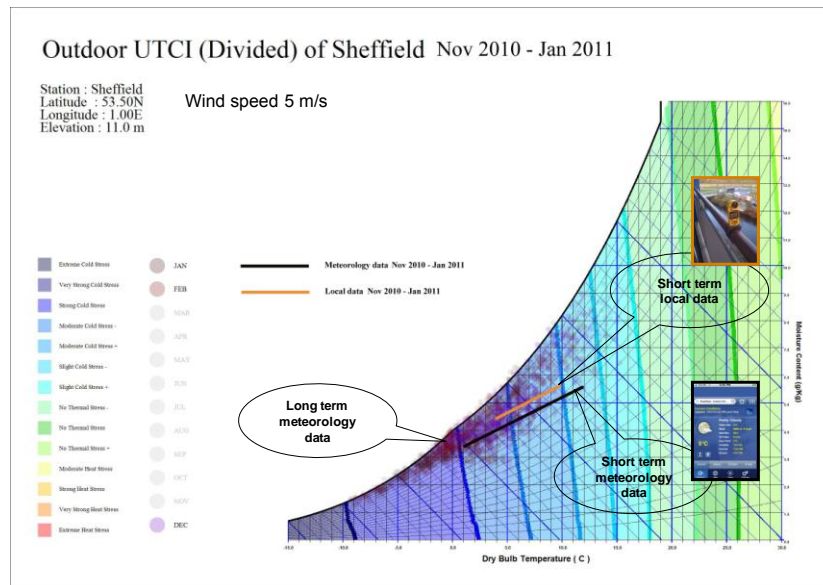

Figure 8. Long term, short term and local weather data of Sheffield in the observation days on UTCI

4- Microclimate of the Observed Places

Comparison the meteorology data with the data of the fixed Kestrel in the reference point and the portable Kestrel in outdoor places shows the relationship between city climate, local climate and micro climate. To find out the relationship between outdoor thermal condition and people's behaviour, a field study research has been done in some days of Nov, Dec and Jan 2010 – 2011 in Sheffield city centre. Different thermal situations were observed in day and night. The results of the data collected in observed outdoor places shows that meteorology station as the city climate has the coldest condition. It is in the slight cold stress zone in calm condition and moderate thermal stress in windy situation according to UTCI index (Fig 9). Fixed data logger as the local climate is warmer than city climate but in the same thermal zone. Portable data logger as the microclimate is one level warmer than local and city climate.

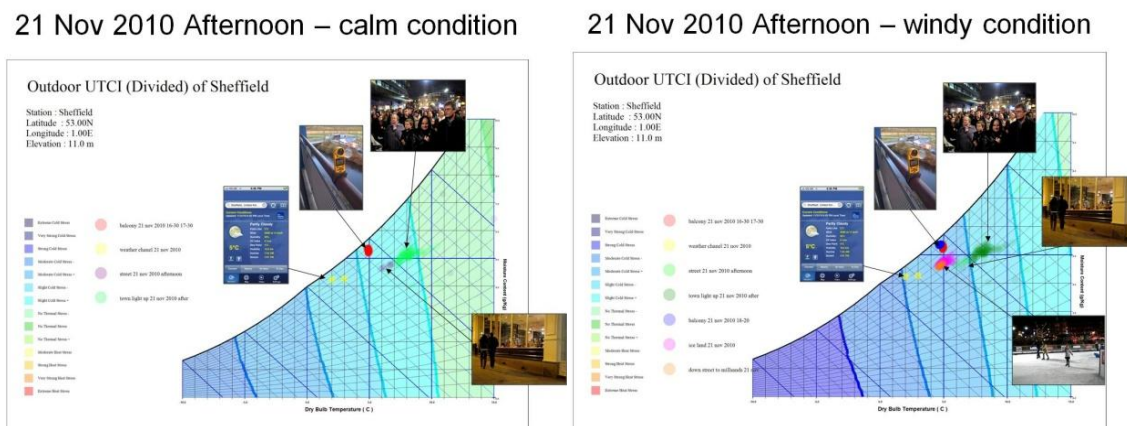

Figure 9. Comparison of the climatic condition of the city climate, local climate and micro climate of the observed places

4-1- Slight Cold Stress Condition

In the observed places in the city centre, in afternoon of 21 Nov 2010 that was light up ceremony, according to UTCI index thermal condition is in slight cold stress in calm condition (Fig 9). Presence of population in one of the main squares of the town has caused 3°C temperature increase from 5°C to 8°C (Fig 10). Temperature increase and excitement of the ceremony may be the reason of presence of children and elderly (Fig 11). In windy situation the wind chill will cause effective temperature decrease from 5°C to 2°C (Fig 10 left) and thermal condition will decrease one level from slight to moderate cold stress (Fig 10 right). By the way happiness of Christmas and availability of winter plays associated with hot drinks and food, has prepared an appropriate condition for long term presence in winter cold night (Fig 11).

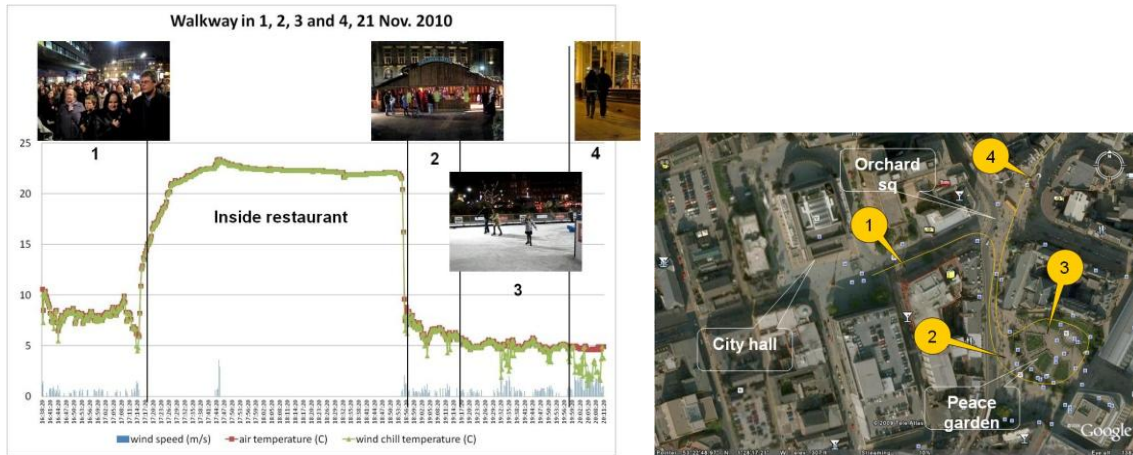

Figure 10. : Presence of population caused 3 °C temperature increase in light up ceremony



Figure 11. Presence of elderly and children wearing supporting warm clothes in exciting afternoon event

Comparing indices of WCET, UTCI, THI and PT shows that according to UTCI, thermal condition is in slight cold stress zone. WCET shows no cold stress in calm situation and low cold stress in windy places. THI shows thermal situation in cold zone. PT shows thermal condition is in low cold stress except for populous places that the temperature will be modified to comfort condition (Fig 12).

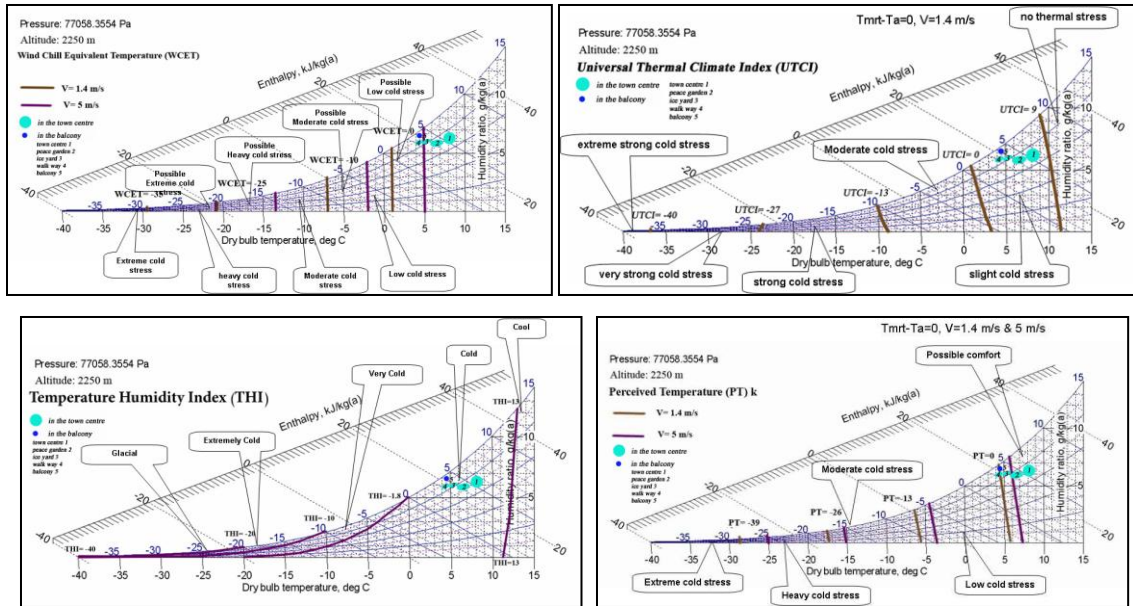

Figure 12. Comparing indices of UTCI, WCET, THI and PT, 21/11/2010

4-2- Moderate cold Stress Condition

In the afternoon of 27 Nov 2010 the thermal condition in the observed places is in higher moderate cold stress zone while local climate is in the lower moderate cold stress zone (Fig 13). In the windy places such as large squares and street canyons, wind chill will cause effective temperature decrease from -2°C to -7°C that made long term presence difficult (Fig 14).

27 Nov 2010 Afternoon

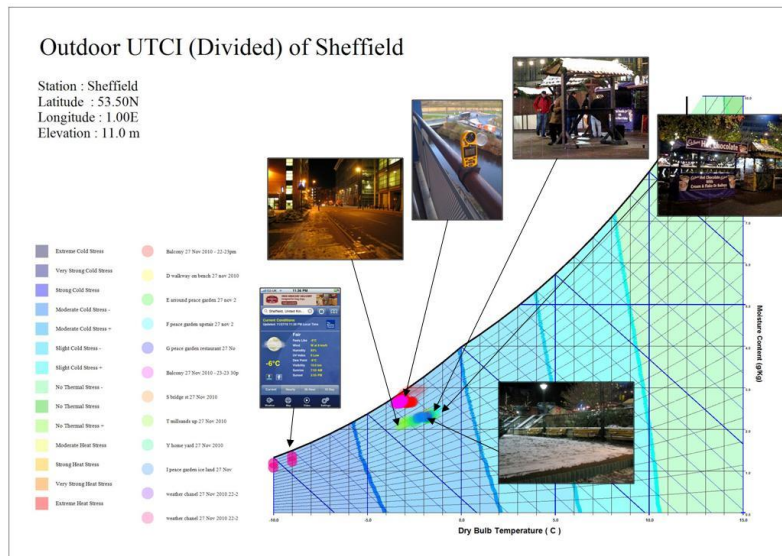

Figure 13. Thermal condition of the observed places – no windy

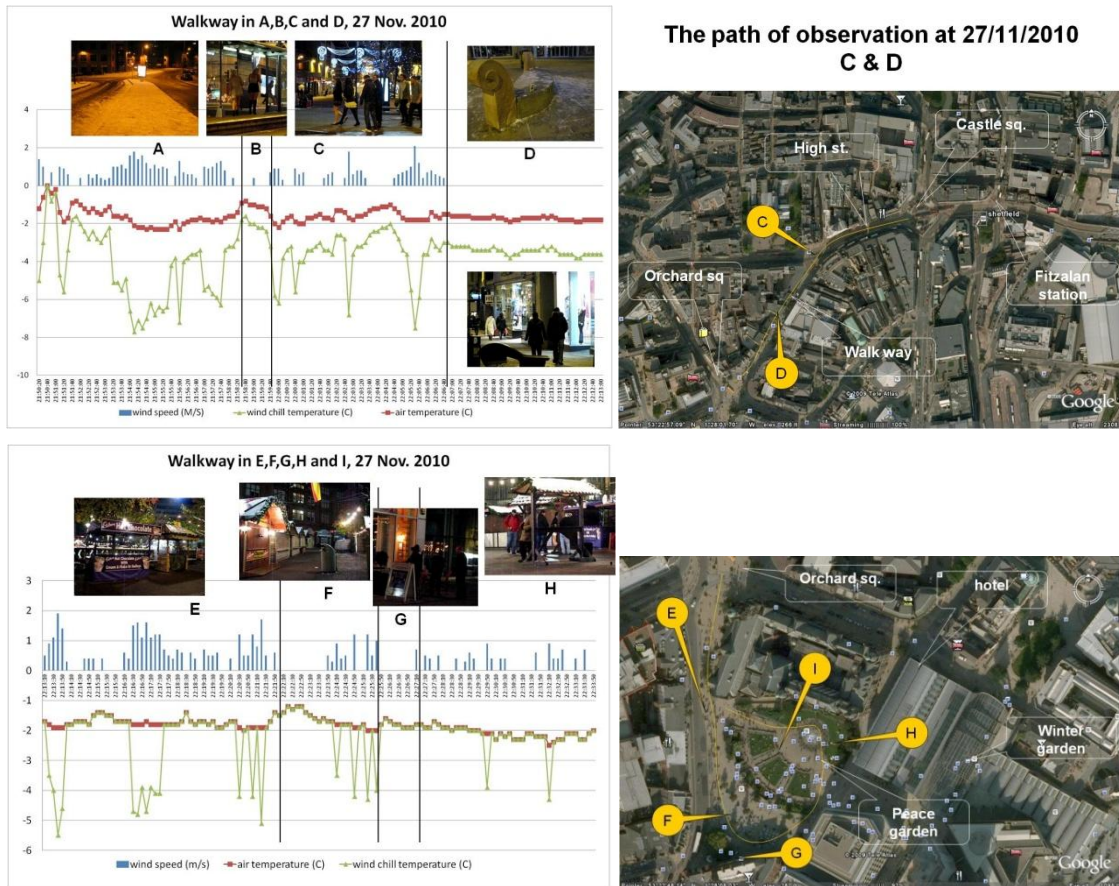

Figure 14. Microclimate condition of the observed points

Windy areas such as open wide places, large squares and street canyons may cause lower moderate cold stress condition. They are not appropriate for long term outdoor presence. Few people were seen passing fast (Fig 15)



Figure 15. Few passing people in windy wide areas in cold night

In bus stations and some other popular places, structures such as booths have prepared wind and rain shelter with appropriate situation for longer exposure time (Fig 16 point M, P and o). In addition in the places with appropriate facilities such as hot drinks and foods, presence of young people is obvious (Fig 17). In spite of that sit in outdoor for eating is not tolerable (Fig 18). Sometime excitement of outdoor event may cause young people to wear fewer clothes that are not appropriate for that cold stress condition (Fig 19). It

seems psychological adaptation¹² make moderate cold stress condition tolerable for short exposure time. Nikolopoulou and Steemers (2003) reported that only 50% of the subjective comfort evaluation can be related to the variation in objective microclimatic conditions. The remaining 50% could be psychological adaptation that is related to how natural the urban space feels, expectations, experience (short- and long-term), time of exposure, perceived control and environmental simulation¹³.

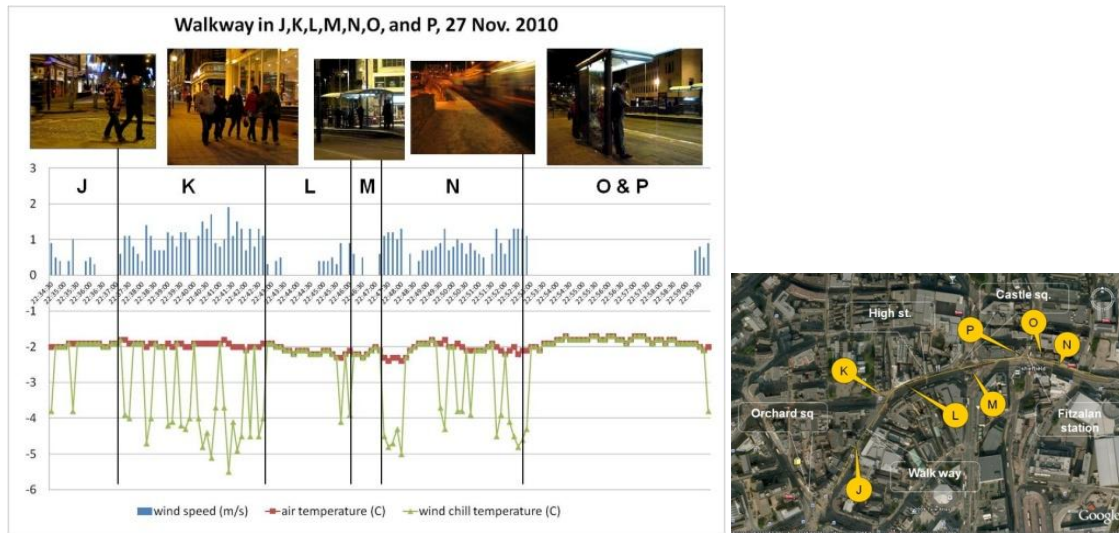

Figure 16. Microclimate condition in windy and wind shelter condition



Figure 17. Wind shelter structures prepare better thermal condition for long term exposure

¹² - A psychological adaptation, also known as evolved psychological mechanism (EPM), is evolved human or animal behavior resulting from evolutionary pressures (Barrett & Kurzban, 2006). EPM's are ongoing processes in their emotions and intellect, that help individuals with their well being whether it's through their mental state of mind or in culture (Medical-Dictionary, 2014)

¹³ - Several investigation have highlighted that human comfort level depends on objective and subjective parameters. Objective parameters include Meteorological parameters (temperature, wind speed, relative humidity and solar radiation) and Skin temperature (forehead and hand temperature). Subjective parameters include Personal parameters (human activity, clothing level, age, origin) and adaptation and acclimatization (preference, expectation, acceptability, habitation) (Metje, et al., 2008).



Figure 18. Few young people presence outdoor in cold night



Figure 19. Young people excitement to wear fewer clothes

In Fig 20 the indices are compared related to the data in the night of 27 Nov 2010. According to outdoor thermal indices, UTCI shows these conditions in moderate cold stress. WCET show it in low cold stress in calm situation and moderate in windy places. According to THI all the observed places are in the lowest border of cold stress condition and increasing of humidity will cause very cold condition. PT Index shows all the observed places in low cold stress condition even with higher wind speed (5 m/s). In these indices there is no difference between high and low moderate cold stresses while people behavior shows meaningful change in such situations. Therefore cold stress indices need to be better modified for lower thermal zones to prepare more accurate prediction related to wind speed and humidity.

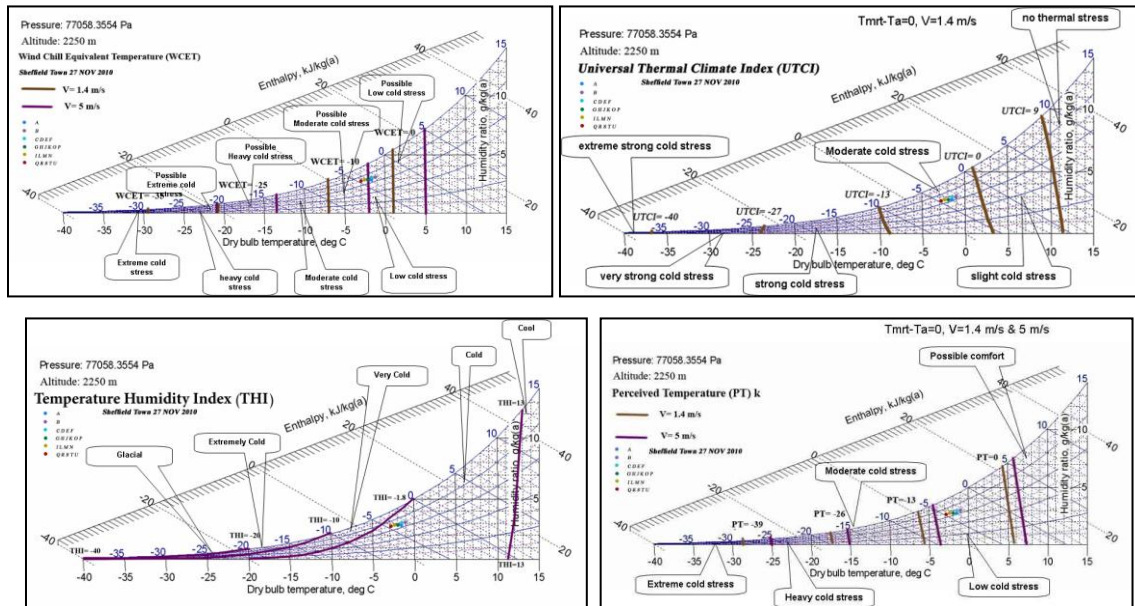

Figure 20. Comparing indices of UTCI, WCET, THI and PT 27/11/2010

4-3- Slight to Moderate Cold stress Condition

In afternoon of 28 Nov (Fig 21) and day of 1 Dec 2010 (Fig 22), by air temperature above zero, many children and elderly were present in the city centre. Windy condition causes effective temperature decrease to wind chill -2°C . In spite of that children and elderly people have long term presence by wearing hat, gloves, shawl and boots. Live music, winter plays, hot drinks and food helps for better toleration to thermal condition (Fig 23).



Figure 21. Observation points in afternoon of 28/11/2010

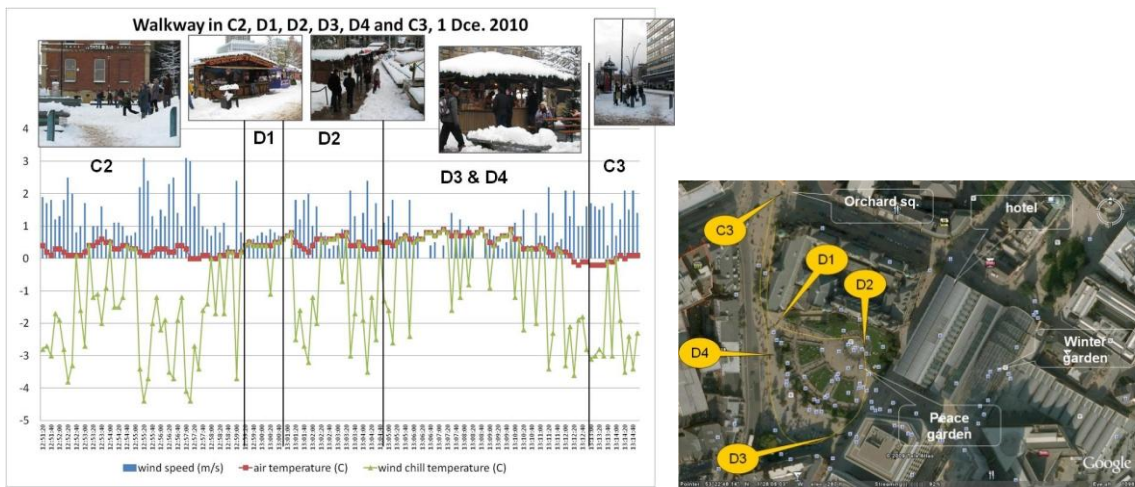
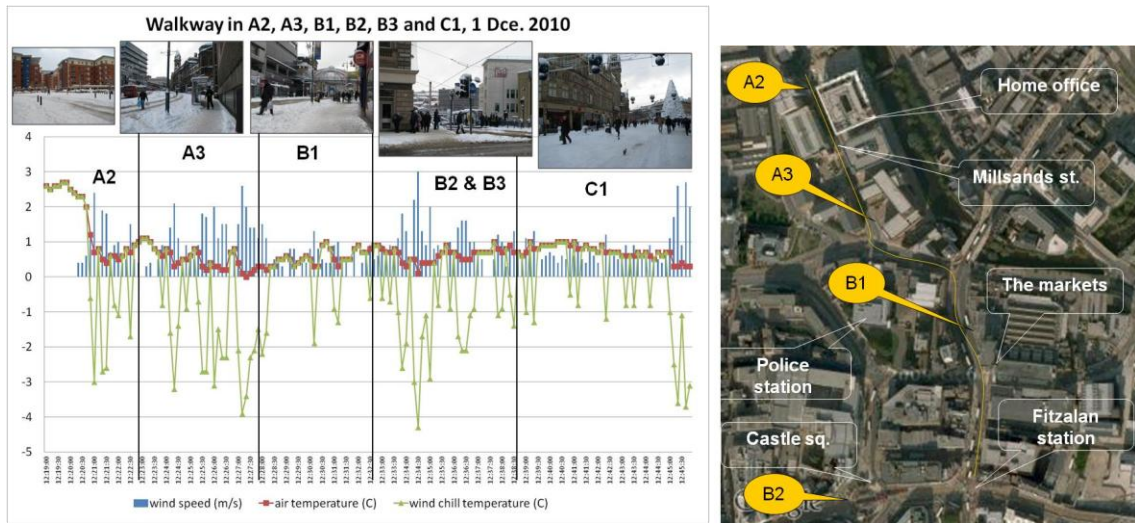

Figure 22. Observation points in the day of 1/12/2010



Figure 23. long term exposure time using appropriate clothing, hot drinks and food in winter entertainments

Excitement is a psychological stimulus to bring people outdoor even in slight cold stress condition. For example in snow days, lots of people come out to enjoy snow plays (Fig 24). Sunshine areas and wind shelters are architectural strategies to provide better microclimate condition for long term outdoor presence.



Figure 24. Excitement of winter events will make more psychological adaptation

Long exposure time for shopkeepers and pitchman is done in their booths by some warmers. Long term outdoor eating is possible in wind shelter places. Presence of children, disables and elders is possible by the help of more facilities such as cover on baby carriage or wearing clothes with more thermal resistance values (Fig 25).



Figure 25. Personal and architectural facilities for long term outdoor presence

The relationship between indoor and outdoor places is important according to thermal shock that may happen to people walking in and out in cold condition. This study shows that indoor public places with short term stay such as banks, shops and trams are not much warmer than outdoor. In most of these places temperature is around 14-15°C that is less than indoor comfort zone (Fig 26 left “C1”). This helps human body to adapt easier with cold outdoor condition in short term stays between indoor and outdoor. In indoor places with long term stay, such as coffee shops, the indoor temperature is fixed to 20-22°C that is indoor comfort zone (Fig 26 right “1G”).

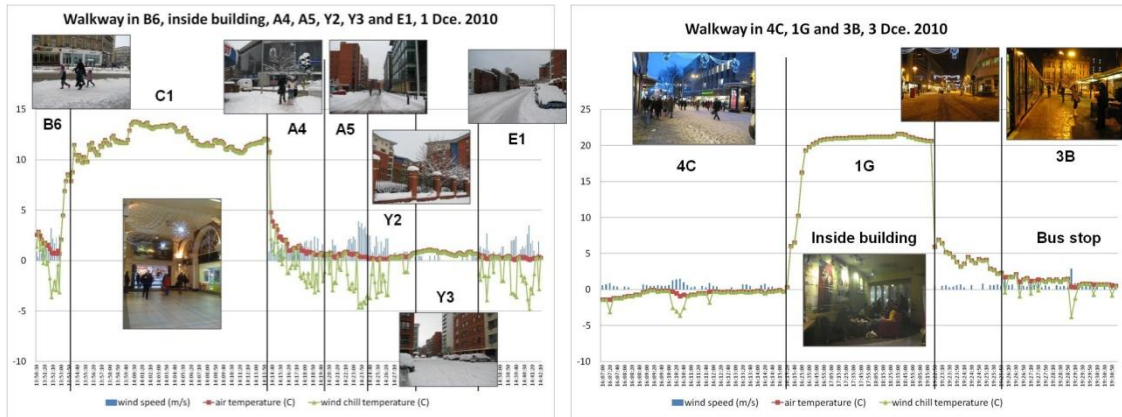

Figure 26. Temperature difference between indoor and outdoor places

This study shows that in air temperature above or around 0°C (-0.5°C to $+0.5^{\circ}\text{C}$) thermal condition is more tolerable than -2°C , therefore more children and elderly people are seen in outdoor areas. Comparison between outdoor thermal indices shows that WCET is in low cold stress zone and UTCI is near higher bound of moderate cold stress zone. THI shows thermal condition in cold stress zone and PT shows it in low cold stress even with higher wind speed (Fig 27). It seems these indices need to provide better sensitive assessment of human thermal sensation in moderate and slight cold stress condition.

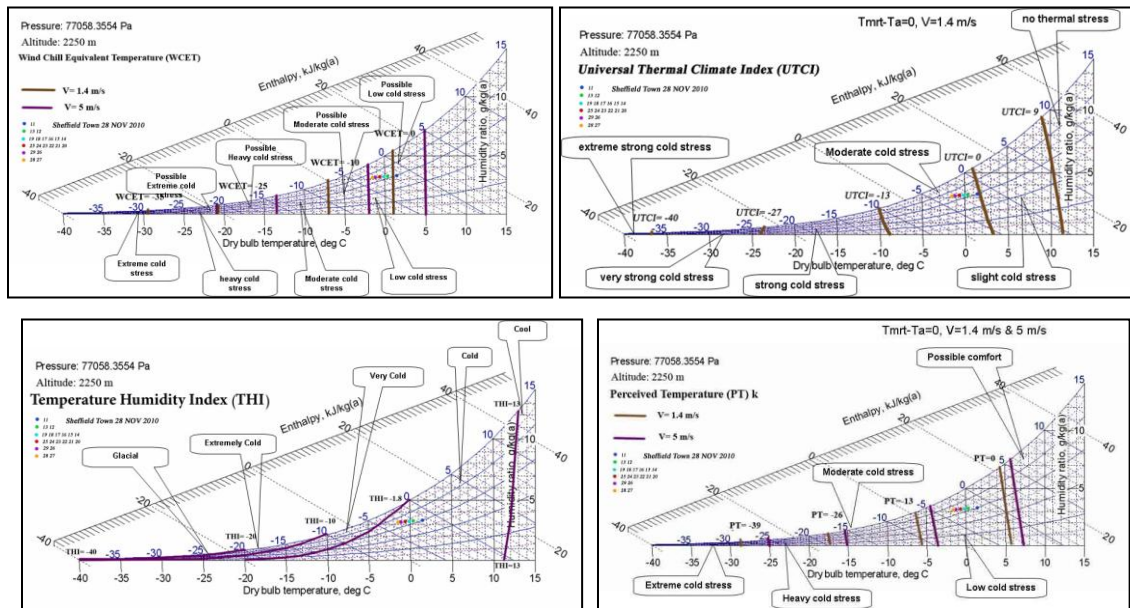

Figure 27. Comparing indices of UTCI, WCET, THI and PT, 28/11/2010 & 1/12/2010

4-3- No Cold Stress Condition

In conditions of no cold stress in 15 Jan 2011 with temperature more than 12°C , the city centre is full of population and many long term activities are happening. Presence of

many children, elderly and disable people is a visible evidence of tolerable thermal condition (Fig 28 and 29).



Figure 28. Presence of population in no cold stress condition

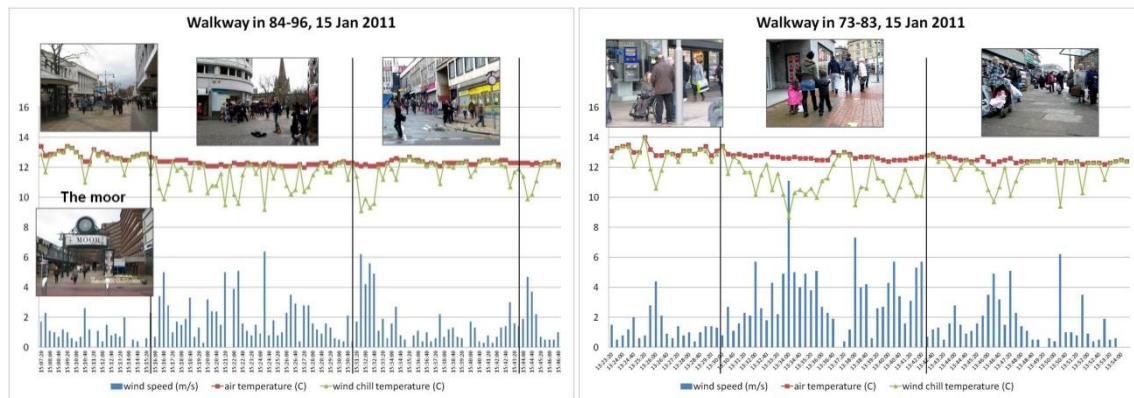
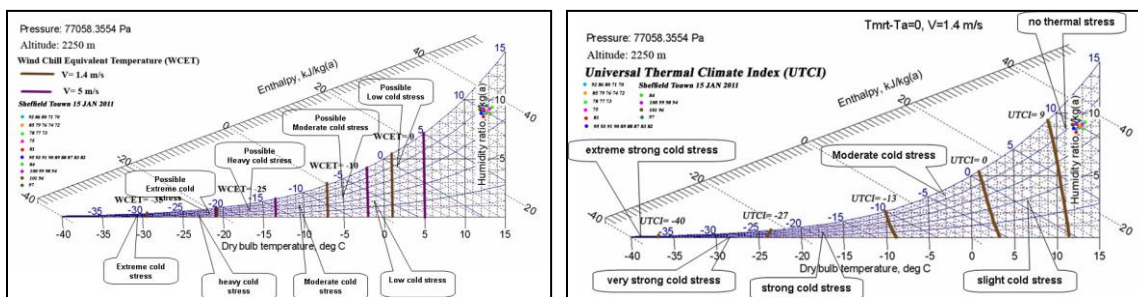

Figure 29. Some observation points in 15 Jan 2011

In the pictures of 15 Jan 2011 (Fig 28 and 29) it is obvious that people are in tolerable thermal condition and most of them even some children do not wear supporting warmer clothes such as gloves, shawl and hat. According to Fig 30, UTCI shows the temperature more than 12°C in no cold stress zone. THI shows it in the zone between cold and cool condition. WCET and PT do not show good sensitivity to temperatures more than 5°C . This research shows meaningful difference between 5°C (slight cold stress) and 12°C (no cold stress) in people's outdoor behaviour. It seems that UTCI has better definition for cold thermal condition with better sensitivity for thermal stress definition.



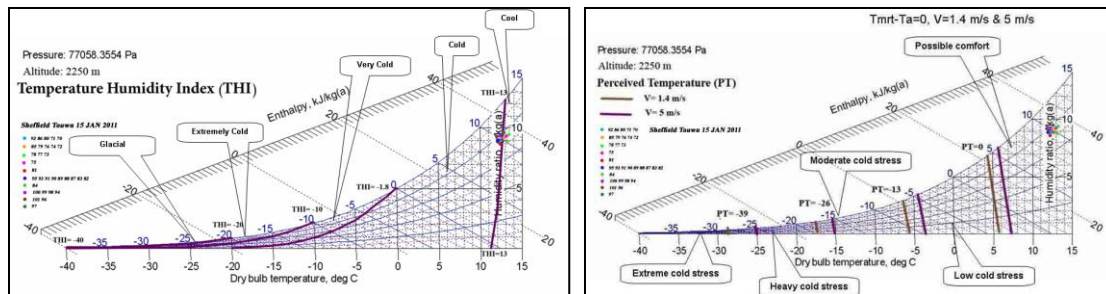

Figure 30. Comparing indices of UTCI, WCET, THI and PT, 15/01/2011

Conclusion

Observations of people's behavior in several days of cold period in autumn and winter of 2010-2011 shows that the temperature more than 12°C in no cold stress zone is adequate for long term outdoor presence for most people. The temperature around $5\text{--}8^{\circ}\text{C}$ is in slight cold stress where long term outdoor presence of people is done by some facilities such as warm clothes and hot drinks and foods. The temperature around zero (-0.5 to 0.5°C) is in slight to moderate cold stress zone depending on windy conditions. In such situation long term outdoor presence depend on the excitement events and architectural strategies such as sunlit areas and wind shelter structures. Supporting clothes as gloves, shawl and hat helps children and elderly to enjoy outdoor events. The temperature less than -2°C with wind chill decrease to -6°C is a critical condition for long term exposure especially for children, elderly, disables and most of the time only young people are seen outdoor. It is called moderate cold stress according to UTCI and WCET in windy condition.

This research shows that among indices that are prepared for outdoor cold stress condition, THI that is sensitive to humidity is not sensitive enough to cold conditions. WCET is more appropriate for very cold situations and is not sensitive to temperatures more than 5°C . PT (the old version of UTCI) shows better sensitivity to temperatures around -5°C and 5°C that are important borders for moderate and slight cold stress respectively according to people's behaviour. UTCI has good congruence with outdoor thermal behavior of people for temperatures around zero and around 12°C that are important borders for slight cold stress and no thermal stress conditions respectively.

Although WCET and UTCI have better definition for thermal cold stress zones, they need to prepare more sensitive explanation for temperature changes in moderate and slight cold stress zone. It seems that UTCI have good potential to become modified for cold conditions by adding enough sensitivity to humidity therewith wind speed in cold conditions.

References

- Aerographer/Meteorology, 2008. *integrated Publishing's Archive Service*. [Online] Available at: http://www.tpub.com/content/aerographer/14269/css/14269_67.htm
- Barrett, H. C. & Kurzban, R., 2006. Modularity in Cognition: Framing the Debate. *Psychological Review*, 113(3), pp. 628-647.

Bröde, P., Jendritzky, G., Fiala, D. & Havenith, G., 2010. The Universal Thermal Climate Index UTCI in Operational Use. *Windsor Conference, UK*, 9-11 April.

CasellaCel, 2014. *Heat Stress in the Workplace, Considerations for industrial Hygienists*, Casella Cel, USA: the Surest Measure of a Changing World.

CDC, 2014. Cold Stress. In: *Workplace Safety & Health Topics*. Atlanta, GA, USA: Centers for Disease Control and Prevention (CDC).

Certificate of Conformity (2008) Kestrel Pocket Weather Meter.

COSTAction730, n.d. *UTCI (Universal Thermal Climate Index)*. [Online] Available at: <http://www.utci.org> [Accessed 2014].

EnergyPlus, 2014. *Energy Plus Weather Data*. [Online] Available at: http://apps1.eere.energy.gov/buildings/energyplus/weatherdata_about.cfm

Environment-Canada, 2001. *Canada's New Wind Chill Index, Available at:*. [Online] Available at: <http://www.mb.ec.gc.ca/air/windtersevere/windchill.en.html>

Fanger, P. O., 1970. *Thermal Comfort, Analysis and Applications in Environmental Engineering*. Copenhagen: Danish Technical Press.

Frostbite, 2014. *wikipedia, The Free Encyclopedia*. [Online] Available at: <http://en.wikipedia.org/wiki/Frostbite>

Heat_illness, 2014. *wikipedia, The Free Encyclopedia*. [Online] Available at: http://en.wikipedia.org/wiki/Heat_illness [Accessed March 2014].

Heat_stroke, 2014. *wikipedia, The Free Encyclopedia*. [Online] Available at: http://en.wikipedia.org/wiki/Heat_stroke [Accessed March 2014].

Heat-Stress, 2008. *Bureau of Meteorology*. [Online] Available at: http://www.bom.gov.au/weather/sa/inside/heat_stress

Jendritzky, G., 2002. *Selected Examples Showing the Feasibility of the Application of a (Future) UTCI*, Kansas City: Business Unit Human Biometeorology.

Jendritzky, G., 2004. *The Universal Thermal Climate Index*, Freiburg, Germany: Deutscher Wetterdienst, Human Biometeorology.

Jendritzky, G., Staiger, H., Bucher, K. & Graetz, A., 2000. *Perceived Temperature: The Method of the Deutscher Wetterdienst for the Assessment of Cold Stress and Heat Load for Human Body*, Germany: Deutscher Wetterdienst.

Kestrel-catalog, 2008. *Kestrel Pocket Weather Meter, Product catalog*. [Online] Available at: <http://www.kestrelmeters.com/>

Kyle, W., 1994. The Human Bioclimatic of Hong Kong, Contemporary Climatology. *Proc. of COC/IGU Meeting, Masaryk University, Brno, Czech Republic*, 15-20 August, pp. 345-350.

Medical Dictionary, S., 2002. *The American Heritage® Stedman's Medical Dictionary*. [Online] Available at: <http://dictionary.reference.com/browse/effective+temperature> [Accessed March 2014].

Medical-Dictionary, 2014. *The Free Dictionary*. [Online] Available at: <http://medical-dictionary.thefreedictionary.com/Psychological+adaptation> [Accessed March 2014].

Metje, N., Sterling, M. & Baker, C. J., 2008. Pedestrian comfort using clothing values and body temperatures. *Journal of Wind Engineering and Industrial Aerodynamics*, Issue 96, p. 412–435..

MetOffice, 1981-2010. *Sheffield*. [Online] Available at: <http://www.metoffice.gov.uk/climate/uk/averages/19812010/sites/sheffield.html> [Accessed 2014].

Nikolopoulou, M. & Steemers, K., 2003. Thermal Comfort and Psychological Adaptation as a Guide for Designing Urban Spaces. *Journal of Energy Build*, Volume 35, pp. 95-101.

NOAA, 2013 December. *NOAA, National Weather Service*. [Online] Available at: <http://www.nws.noaa.gov/om/windchill/> [Accessed March 2014].

NWS-USA, 2001. *Wind Chill Temperature Index*, USA: National Weather Service .

Osczevski, R. & Bluestein, M., 2005. The New Windchill Equivalent Temperature Chart. *American Meteorological Society*, Oct..

OSHA, 2008. Heat Stress, Chapter 4. In: O. T. M. (OTM), ed. *Occupational_ Safety_ & Health_ Administration*. OSHA Technical Manual (OTM) ed. Washington DC: U.S. Department of Labor,, p. Chapter 4.

Richards, M. & Havenith, G., 2007. Progress Towards the Final UTCI Model. In: *Mekjavic, IB; Kounalakis, SN; Taylor, NAS (eds.): Environmental Ergonomics XII, Biomed, Ljubljana*, pp. 521-524.

Shitzer, A., 2007. *Assessment of the Effects of Environmental Radiation on Wind Chill Equivalent Temperatures*, Israel: Israel Institute of Technology.

Staiger, H., Bucher, K. & Jendirtzky, G., 1997. Gefuhltle Temperature. *Annalen der Meteorology*, Volume 33, pp. 100-107.

Tahbaz, M., 2011. Psychrometric Chart as a Basis for Outdoor Thermal Analysis. *International Journal of Architectural Engineering & Urban Planning*, 21(2), pp. 95-109.

Tahbaz, M. & Amini Behbahani, P., 2011. *SIKRON Software*, Tehran, Iran: Designed in Shahid Beheshti University.

Thom, E. C., 1959. The Discomfort Index,. *Weatherwise*, Issue 12, pp. 57-60.

Unger, J., 1999. Comparisons of Urban and Rural Bioclimatological Conditions in the Case of a Central-European City. *Int. J Biometeorol*, Issue 43, pp. 139-144.

wiki/Sheffield, 2014. *sheffield climate*. [Online] Available at: <http://en.wikipedia.org/wiki/Sheffield> [Accessed 2014].

Wojtach, B., 2014. *UTCI Calculator*. [Online] Available at: <http://www.utci.org/utcineu/utcineu.php> [Accessed 2014].

Yilmaz, s., Toy, s. & Yilmaz, H., 2007. Human thermal comfort over three land surfaces during summer in the city of Erzurum turkey. *Atmosfera*, 20(3), pp. 289-297.

Proceedings of 8th Windsor Conference Counting the Cost of Comfort in a Changing World

Cumberland Lodge, Windsor, UK, 10th-13th April 2014
Network for Comfort and Energy Use in Buildings <http://nceub.org.uk>
Windsor Conference 2014 www.windsorconference.com

ISBN 978-0-9928957-0-9

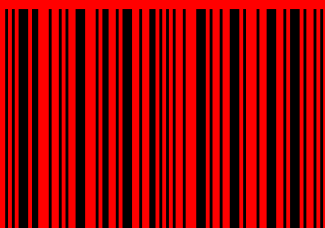

9 780992 895709 >

Published by NCEUB 2014
To order go online to www.nceub.org.uk